

UMASS/AMHERST

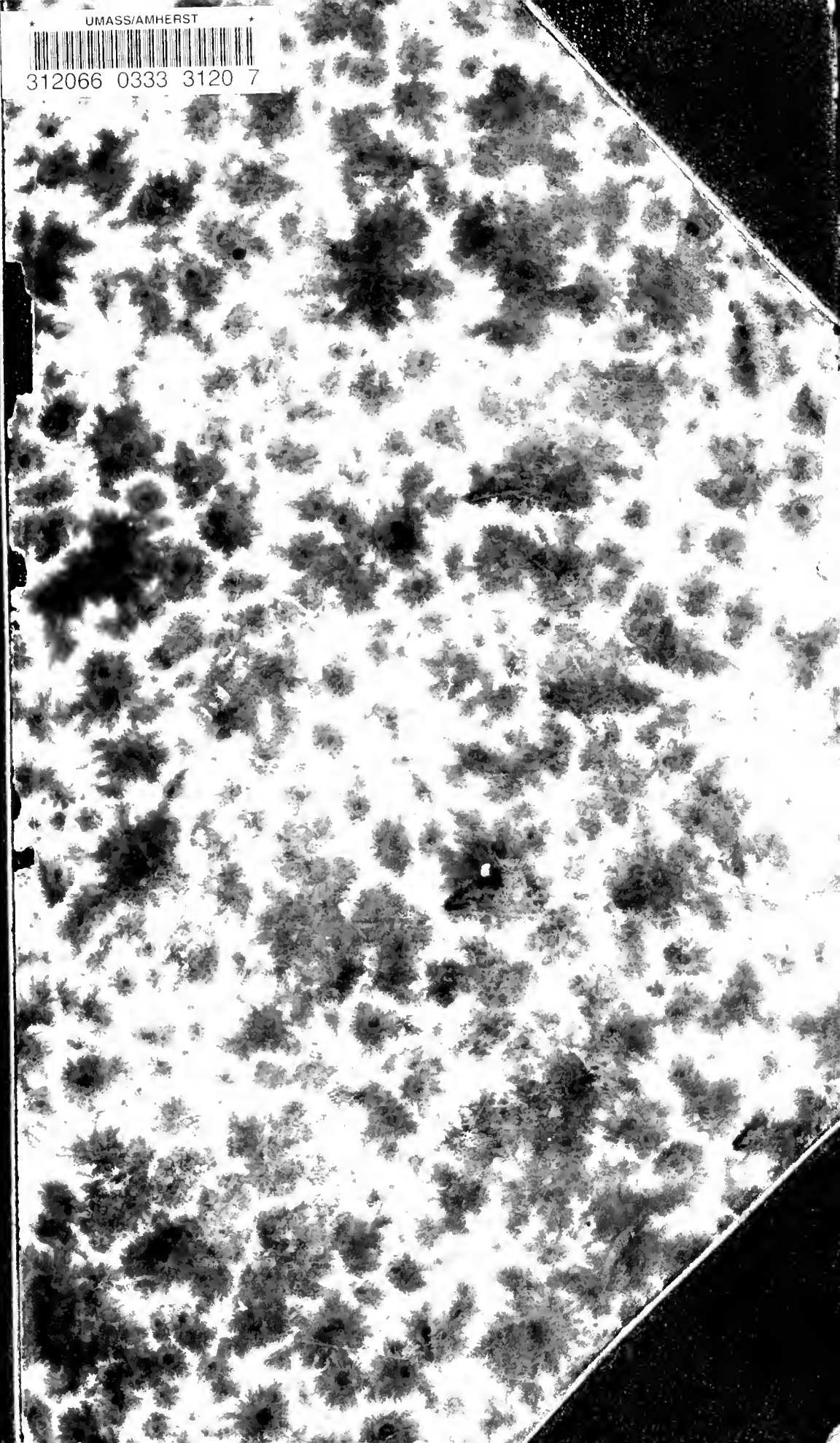

312066 0333 3120 7



55
19
J. W. ...
1950

LIBRARY
OF THE

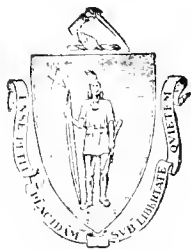

MASSACHUSETTS
AGRICULTURAL
COLLEGE

NO. _____ DATE _____

SOURCE _____

CPex
J8265

MADEIRA
AGRICULTURAL
COLLEGE
LIBRARY





THE
JOURNAL OF HORTICULTURE,
COTTAGE GARDENER,
COUNTRY GENTLEMAN,
BEE-KEEPER, AND POULTRY CHRONICLE.

A JOURNAL OF GARDENING, RURAL AND DOMESTIC ECONOMY, BOTANY, AND NATURAL HISTORY.

CONDUCTED BY

GEORGE W. JOHNSON, F.R.H.S., AND ROBERT HOGG, LL.D.

THE FRUIT AND KITCHEN GARDENS, by Mr. J. Robson, Gardener to Viscount Holmesdale, M.P., Linton Park; and Mr. E. Lunckhurst, Old Lands, Buxted, Sussex.

THE FLOWER GARDEN, by Mr. G. Abbey; "Ayrshire Gardener;" and Mr. T. Record, Gardener to the Marquis of Salisbury, Hatfield House.

STOVE, GREENHOUSE, and WINDOW GARDEN, by Mr. R. Fish, Gardener, Putteridge Bury, near Luton.

FLORISTS' FLOWERS AND FLORICULTURE, by the Rev. H. H. Dembrain.

GARDENING CALENDAR, by Mr. William Keane.

POULTRY-KEEPING, by Mr. J. Bally; E. Hewitt, Esq.; and L. Wright, Esq.

PIGEONS, AVIARY BIRDS, &c., by "Wiltshire Rector;" W. A. Blakston, Esq., and others.

BEE-KEEPING, by T. W. Woodbury, Esq.; "B. & W.;" and Mr. S. Bevan Fox.

HOUSEHOLD ARTS, by the Authoress of "My Flowers," and others.



VOLUME XIX., NEW SERIES.

VOL. XLIV., OLD SERIES.

LONDON:

PUBLISHED FOR THE PROPRIETORS, 171, FLEET STREET.

1870.

LONDON :

PRINTED AT THE JOURNAL OF HORTICULTURE OFFICE,
171, FLEET STREET.

TO OUR READERS.

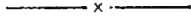

THE pen had been dipped into the ink and we were hesitating how to commence our customary address, when the mournful cry of "Poor frozen-out Gardeners" reached us from the street. We looked out upon those thus wailing, but felt no pity for them—they were unmistakeable impostors. The words "Frozen out," however, have summoned up many thoughts—thoughts of the plants and of their cultivators "frozen out" by the war-ravages now desolating France—thoughts of the wise forecast of those gardeners who reserved in-door employment for such times as these, when from out-door employment they are "frozen out"—thoughts of the "bonny blithe blink of their ain fireside," by which many a gardener, many a fancier of the pets within this Journal's province, has that fireside made more cheery by our pages. This last thought adds to our cheeriness, for there is no brighter pleasure than that beaming from a knowledge that we make others happier. That our pages do effect that, our hope and purpose, is no vain suggestion of self-complacency.

We have the testimony before us in many letters, and those letters justify the still higher gratification arising from a certainty that we benefit as well as please. We could extract from many letters bearing this testimony, but a brief one must suffice—the letter is from a well-established seedsman and florist. "It may perhaps amuse you when I say that some years ago, when I was farming our own estate, a friend lent me a bound volume of your Journal, the reading of which had the effect of turning me into a florist, and I believe, had it not been for that, I should never have entered into this line of business, though always passionately fond of flowers." Such certificates that we minister something to the happiness and advantage of others makes our fireside blink more bonniely; but it does not make us forget that the good we thus achieve is due chiefly to the kindly hearts, able heads, and ready pens which are combined to enrich our pages. That combination will be continued and strengthened. This, we confidently hope, will secure to us your continued support, and then certainly we shall not be "Frozen out."

INDEX.

- AREXAS GROSSULARIATA**, 516
Achmenes, culture, 519; propagation, 51
Actinia, the Strawberry, 413
Achyranthes, 316
Adiantum, Feet, 210; pedatum, 69
Acapantius treatment, 815
Acazorus procerus, 328
Albborough Poultry Show, 153
Algarian gardening, 290
Alamanda violacea and culture, 357
Allerton Poultry Show, 111
Alternanthera Lindenii, propagating, 278
Aiton Towers, 287, 307
Amateur, or Florist? 51; gardener, the, 26, 163, 245
American blight, 334, 337
American winter garden, 812
Amorphophallus bulbiferus culture, 364
Anagochilus Dawsonianus sickly, 273
Andalusians, 329
Angeles, winter-blooming, 306
Annals, for autumn sowing, 192; for greenhouse, 315
Anomatheca areolata, 128
Anthomus pomorum, 413
Anthurium ornatum, 26; Scherzerianum, temperature for, and propagating, 16
Antipodes, gardening at the, 810
Antirrhinum, list of, 171
Ants, driving away, 108; to destroy, 135; in dwelling-house, 218
Aphides, tobacco and bitter aloes for destroying, 91; on Cabbageworts, 273
Apples—gathering fruit, 211; grafts, 243, 262; for small gardens, 322; pyramids unfruitful, 212; select, 233; stocks, 243, 308, 346; training miniature, 171; for walls, 334; for north-west of England, and pyramids, 377; Burr Knot, 282, 326; Ecklinville Seedling, 268, 284, 324; Paradise Pippin, sowing, 437; on Pommer de Paradis, 236; on French Paradise, 374; Jacques Lebel, 274; Summer Thistle, 284; Whorle Pippin, 284
Appleton-Street Poultry Show, 93; Floral and Agricultural Show, 104
Apricots, branches dying off, 90; profitable standard, 245; unfruitful, 203
Aralia Sieboldii, is it hardy? 426
Araucaria imbricata, liehen on; propagation, trees for, 316
Arbutus procera transplanting, 356
Aristolochia barbata, 393
Arkleton, 283
Arthropteris, climbing, 386
Artichokes, 133
Artillery plant, 24
Arums in a pot, 815
Ash trees, insects attacking, 110; treatment of hollow, 386
Asimenia triloba, 165
Asparagus, beds, salt for, 316; salting, 354; Kale, 457; management, 233; planting, 264
Aspid. green on, 69
August, plants flowering in, 262
Auriculas, in 1870, 449; Alpine, 393
Australia, sending cuttings to, 148
Avenue planting, 252
Awards at poultry shows, 378, 398, 405
Aykleyheads, 166
Aylesbury Poultry Show, 235
Aylesbury Ducks' bills yellow, 320
Ayr Pigeon and Bird Show, 401
Azaleas, leaves falling, 473; browned, 69; leaves yellow, 457; out of doors, 51; select Indian, 357
BACON, INSECT IN, 238
Bacon culture, 69
Bamboo culture, 191
Bank, plant for sloping, 438
Bantams—dying, 424; breeding, 526; Game, colour of, 361; White, clean-legged 175; classes for, 264, 340; feather-legged, 820; prizes for at Manchester, 499
Barkerias, winter-blooming, 306
Baron Mackenz, 267
Baron-staple Poultry Show, 18
Barrow, Staplehurst Roller, 47
Barton Poultry Show, 521
Basnets, amoung-plated for poultry, 479; plants for, 197, 230
Batmore Park, 142
Bay, Sweet, pruning, 79
Beans, various, 169; Scarlet Runners, 159
Bedding plants in 1871, 129, 147, 227; propagating, 151, 251; a few, 154; in the north, 209; gifts of, 282
Beech trees, insect on, 16; mast and fungus, 199; white substance on, 218; the Purple, 491; for chalky soil, 494
Bees—ants in hive, 56; attacking chickens, 17; bar frames, 7; early supers, 19; coal tarring bee-house, 525; breeding late, 414; building outside of hive, 175; carboxic acid, uses, 257; cells, structure, 277; driving, 65, 248; drones in November, 423; drone slaughter, 29; egg-eating, 414; feeding, 362; feeding and strengthening, 176; foul brood, 463, 505, experiments with, 342, experiments with permanganate of potash, 493, 423; remedy for, 324; glasses, remedying shape of, 319; health pasturage, 38; in old hive, 56; hives frame, 138; large, 7; small hives, 55; at Liskard Show, 138; honey cheap, 278, insipid, 506; taking, 95; honey harvest, 187, deficient, 96, in Jersey, 94; commencing to keep, 20, 95, 196; leaving their hive, 18; taking lime water, 38; Ligurians, queens introductions, 18, 95, in Jersey, 55, 94, second swarms, 423; at Manchester, 175; narding, 38; queens, contests, 277; controlling fertilisation, 95, 155, 217, 218, 288, 297, 485; how long are queens and workers in their cells? 55, 115, 195, 297, 313; when do they commence egg-laying, 115; introducing Ligurian, 18, 95; removing, 116; robbing, 231; in Scotland, 175; stocks dwindling, 56, removing, 320, 506; in West Suffolk, 95, supers early, 18, removing, 278, supering, 29, swarms, artificial, 28, abnormally early, 360, obtaining early, 258, laying, 188, successful, 20, uniting, 196; swarming, 4, 257; not swarming, 58; wasps, 176
Beet—for a flower garden, 145, 179, 181, 200, 281; for spring gardening, 273; storing, 281
"Beetroot Sugar Question," 470
Belfast notes, 222
Belmont Poultry Show, 18
Belladonna Lily culture, 33
Berberis Darwinii, 78
Berberis, the common, 180; keeping on bush, 356
Berkshire Root Show, 430
Berwick Ornithological Show, 483, 501
Beta, Beta chilensis, 39
Beverley Poultry Show, 17
Bincley Poultry Show, 194; Pigeon Show, 568, 522
Bird shows, management of, 216
Birmingham Poultry Show of 1870, 24, 274, 419, 438, 480; Philopeterston Society's Show, 841
Bishop Auckland Poultry Show, 35
Blackberry, wine, 258
Blackpool Poultry Show, 136
Bliebells and Harebells, 185
Boiler, 316; Foster's for small house, 258; for greenhouse, 473; heating from house, 255; proposed, 247; Weeks & Co.'s duplex, 161
Bone dust, 96; for chickens, 173, 226
Border, re-arranging, 877
Borecoles, 509
Borning rods, 301
Boston Poultry Show, 35
Botanic (Royal) Society's Show, 5
Bougainvillea lateralis, 836
Bouquets, 351; leaves for, 357
Box, 79; edging, 547; replanting, 251
Brachmas—chickens' legs weak, 116; ducks' comb, 176; colour, 351; legs diseased, 361; cross-breeding, 298; eyes swollen, 383; exhibiting, 464; feeding for exhibition, 441; twisted thigh, 384; losing feathers, 451; history of, 296; foot swollen, 298; prize for Light, 319; cock's markings, 95; moulting, 196, 424; pullets and cock, 384; new standard for, 520; culture hocks, 424; war on, 431; weak-legged, 258; weight of, 261
Breconshire Poultry Show, 256, 468, 486
Brewer's grains for fowls, 278
Brick dust for pasture, 355
Bricks, size, 46, 437
Brisbane Botanic Gardens, extracts from the Report of, 47, 67
British Museum, botanical department, 244
Broccoli, laying down, 354
Brodiaea coccinea, 204; culture, 26
Brussels Sprouts, cutting, 209; early, 230
Bulb culture, 317
Bullfinch's foot swollen, 362
Ruffell Poultry Show, 17
CABBAGES—**APHIS** ON, 169; **CATERPILLARS**, 190; culture, 250, 270; large, 13; planting, 315
Caecules, pruning, 91
Caladium, culture, 519; esculentum as a vegetable, 61; propagation, 51
Caladiums, wintering, 169
Calanthes, winter-flowering, 365
Calceolarias, for bedding, 90; culture of herbaceous, 118
California, experiences of, 81; horticultural visit to, 245
Calochortus Leichtlinii, 267
Cambridge Poultry Show, 36
Camellias—budding, 457; thinning buds, 292, 315; buds falling, 473; out of doors, 51; liquid manure for, 458; leaves falling, 91; potting, 212; soil treatment, 469
Canada, poultry in, 17
Canaries, lice on, 96; not pairing, 96; pairing various, 176
Canarina campanulata, 123
Canary bird, 276
Canker, 377
Cannas—culture, 253; seed sowing, seeds not germinating, 199; seedling treatment, 179; wintering, 33, 315
Capel Manor, 242
Carnations—abnormal, 151; Chive, and Picotee cuttings, 150; fertilising, 39; and Picotees at Slough, 41; seedling, 64
Carter & Co's prizes for roots, &c., 270
Cases for plants, 10
Cassia mimosoides, var. Telfairiana, 471
Castle Howard, 372, 353
Caterpillars, on Cabbages, 159; and grub, 189; on October, 327; November, 391; in December, 470
Cauliflower, culture, 133, 210, 250, 355; maggoted, 356; planting, 89; plants, framing, 315
Celery, blanching, 409; culture, 170, 210; planting, 32; protecting, 455
Centaurea candidissima cultiva, 416; propagation, 356
Cercis fulgidus, 264
Chalk, trees for, 478
Chapman's flower cases, 268
Charcoal and coke fumes, 830
Charring refuse, 162, 234
Chatsworth, 432, 452
Chaucer's Chanticleer, 883
Cherries—early, 91; varieties as pyramids, 2; for walls, 334; Late Duke, 417
Chickens—dying wholesale, 56; separating, 19; not true-colored, 464; watching the, 52
Childwell Nurseries, 223
Chinchilla Rabbit, 37
Chippingham Poultry Show, 412
Christmas Rose, 254, 439
Christmas poultry market, 519
Christmas temperature in 1864, 276
Chrysanthemums—among the, 370; Anemone-flowered, 398; culture, 448, 472; at Liverpool, 468; mildewed, 316; retarding, 356; seedlings, 492; select, 397; Sensation for spring, 356; Show, 348; sowing, 458
Cider making, 258
Cinchona culture, 312
Cinerarias—falling, 357; maritima culture, 233; not thriving, 293; oyster shell powder for, 458
Cirekheaton Poultry Show, 94
Clematis—for north wall, 151; in pots, 33; select, 252
Clerodendron Balfourianum, pruning, 91
Cleveland Agricultural Society's Poultry Show, 215
Climbers, for a south-west wall, 213; for low wall, 278; for north wall, 357
Chiltheroe Poultry Show, 111
Clusia odorata, 257
Coal ashes, 336
Cochin-Chinas—breeding, 257; comb white, 526; dying, 320; feathers projecting, 298; feeding, 56; pullets dying, 384; nourishing, 444; vulture-tipped, 404; White, 93; weight of, 361
Cockatoo feather-eating, 456
Cockchafer, 515
Cockerel for exhibition, 488
Cock spurless, 38; with toe mutilated, 484
Colognes, winter-blooming, 203
Cold, intense, 514
Colours, for bedding, 171; losing colour, 51; Verschaffelti, 90
Colour in tree scenery of gardens, parks, and landscapes, 82
Colymbian Society, City, 175; the Scottish, 418; Show, 503; Northern Counties, 419
Combustion, slow, 521
Comfits, Californian, 111; insects attacking, 79
Conservatory, heating, 516, 527; plants for, 274
Copings for walls, 239
Corbridge, ramblers about, 177
Corchorus japonicus prunus, 458
Corwall, early produce from, 202
Correa leaves falling, 458
Cottage garden shows, sales at, 491, 512
Cottingham Poultry Show, 215
Cotton seed for paper, 24
Covent Garden Market, 20, 51, 56, 196, 238, 362, 486, 526
Cows, Ash leaves as provender for, 76
Crasula, pruning, 91
Creeper for a bank, 398
Creeper, characteristics, 258; derivation, 254; comb and toes, 278, 404; gills, 414
Crop-bomb chickens, 361, 374
Croton leguyi, 457
Croydon Colymbian Society, 382; Poultry Show, 91
Crystal Palace, garden, 267; Metropolitan Florists' Society's Show, 194, 182; Poultry Show, 173, 174, 319, 358, 358, 382, 459, 500; entries, 500; prizes, &c., 506
Cucumbers—aphis on plants, 24; culture, 32, 374; culture and disease, 231; damping-off, 69, 151; leaves injured, 177; leaves scorched, 69; notes on, 170; scabbed, 397
Currant, Black, 91; its culture and profitability, 16, 97; moth, 515; Red, planting, 468
Cuscuta zenus, 203
Cuttings, management of, 263; struck, 292; planting, 69, 151; leaves injured, 177; scabbed, 397
Cyclamen persicum, 262, 514; seedlings blooming at ten months old, 498; blooming early, 514; after flowering, 519
Cymbidium canaliculatum, 165
Cypripedium candidum, 165

- Tulip Tree seeds, 315
 Tambridge Wells, Spanish fowls at, 342
 Turf, beds on, 556; heaps, 134; under
 Lines, 61
 Turkeys, 62; breeding, 156; Cam-
 bridge, 464; heads swollen, 434;
 verigo in, 278; young dying, 196
 Turnips, grubs destroying, 242
 Tussocks *Parfara variegata*, propa-
 gating, 273
 Tydæus, aphid on, 835
- ULSTER, HORTICULTURAL SOCIETY FOR,
 329
- VALLOTA PURPUREA CULTURE, 16, 213
 Vanda Cathcarti, 26
 Vases, plants for, 197, 223
 Vegetables, better than nothing, 19,
 37; crop, profitable, 215; for exhi-
 biting, 191; for the besieged, 421;
 gardeners' prizes for at Nottingham
 Show, 42
 Vegetable Marrows, 163; cooking, 196
 Veitch, memorial, 332; Mr. John
 Gould, death of, 132
 Verbenas, for bedding, 198; new bed-
 ding, 147; soil for Sweet-scented, 376
 Veronicas, 356
 Vine border, heating, 272; making,
 479
 Vinegar plant, 109, 138
 Vinery, and conservatory heating,
 361; arrangement of, 497; building
 over a vine, 191; burning sulphur
- VINERY—Continued.
 in, 172; planting a small cool, 416;
 greenhouse, 478; ground, 268, 457,
 478, 491, 519; stove for, plant-cuttings
 in, 437
 Vines—airial roots, 23, 31; borders,
 199, 212, 498; bush in pots, 173; cow
 dung for, 243; cuds growing, 488;
 commencing forcing, 456; glass
 covering, 397; in greenhouse, 356;
 for ground vineries, 519; injured,
 212; leaves diseased, 34, as food for,
 234; removing, 34; manuring, 435,
 487; mulched, 3, 16, 29; for outside
 border, 479; planting, 169, 233, 316,
 376, 457; pruning, 272, 376; in pots,
 153, 316, 376; removing, 498; protect-
 ing roots, 272; select, 508; for a
 small house, 478; shoots dying, 33,
 152; training, 438; transplanting,
 438; for an unheated house, 137; on
 a wall, 316; on glass-covered walls,
 519; on an open wall, 376; on back
 wall of a vinery, 91; watering in
 conservatory, 174. See also *Grapes*.
 Viola cornuta, as a bedder, 195; dy-
 ing, 192
 Violets, culture of Neapolitan and
 Russian, 171; Czar, culture, 316;
 not flowering, 477; culture of Rus-
 sian, 497; under glass, 375
- WAREFIELD POULTRY SHOW, 193
 Walls, 150; gravel, to make smooth,
 213
- Walls, protecting blossoms of fruit
 trees on walls, 283; glass, 66, 86;
 plant for shaded, 416
 Walnuts, keeping, 179, 315, 234
 Walsall Poultry Show, 256
 War, French losses from, 252; inter-
 rupts French floriculture, 388
 Warrington Poultry Show, 93, 153
 Wasps attacking fruit, 198; not com-
 mon at Southampton, 116
 Water Cresses grown out of water,
 225
 Water, dirty, 33; supply of, 134
 Watering, 230, 250, 494, 495; and no
 watering, 48; is it needed? 11
 Watford Poultry Show, 593
 Wayside jottings, 244
 Weather prognostics, 414
 Weeds, 128, 204, 366; creeping-rooted,
 282; eradicating, 234
 Weeds' one-boiler system, 34
 Week, work for, 12, 31, 48, 67, 88, 107,
 132, 149, 168, 188, 210, 229, 249, 269, 290,
 312, 332, 354, 373, 395, 419, 435, 455, 476,
 495, 516; doings of last, 13, 32, 43, 68,
 89, 108, 133, 150, 169, 189, 210, 230, 250,
 270, 291, 313, 333, 355, 371, 396, 414, 436,
 455, 476, 496, 517
 Weight, feeding fowls to increase,
 464; of fowls influencing judges, 318
 Wellingtonia gigantea and the rab-
 bits, 352
 Wellington Poultry Show, 236
 Welshpool Poultry Show, 256
 West of England Poultry Show, 500
 Westward Ho Poultry Show, 74
 Wetherby Poultry Show, 235
- Wheeling, 415
 Whitley Canary Show, 153, 216,
 Poultry Show, 137, 154
 Whitworth Poultry Show, 174
 Wizardia treatment, 473
 "Wild Garden," 203
 Willow Herb as a bedder, 267
 Willow with curled leaves, 417
 Wintering plants, in a cold vinery,
 233; in a room, 358
 Winter, plants flowering in, 192; pro-
 tection for, 134; vegetables, 169
 "Wines Home-made," 55
 Wiring a fruit wall, 191
 Wonders of an amateur, 469
 Woodlice, destroying, 254; in Cucam-
 ber frame, 152
 Wood Leopard Moth, 27
 Woodsome Poultry Show, 154
 Woodstock Poultry Show, 257
 Woolhope Naturalists' Club, 310
 World's wear and tear, 6
 Worms, a rare remedy, 446; banish-
 ing, 469; driving out of pots, 91, 499;
 in lawn, 417
 Worsley Poultry Show, 173
- YEW, TRANSPLANTING IRISH, 557
 York Poultry, &c., Show, 483
 York Rabbit Show, 332, 433
- ZEPHYRANTHES ROSEA,
 Zenzera rescili, 27
 Zinc exposed to fire, 234

WOODCUTS.

	PAGE.		PAGE.
Abraxas grossulariata	516	Oleandra nodosa	886
Alton Towers views	288, 289, 308	Orchard, Gilbey's glass	68
Anemones, Sea	435	Pear, Avocat Allard	828
Bees, feeding	372	" Broekworth Park	268
Boiler, proposed	348	" insects	11, 28,
Bracket for coping boards	389	" 206	
Castle Howard views	373	Pigeon, Almond Tumbler	339
Chatsworth Conservatory	424	" Barb	524
Crystal Palace, flower border at	297	" Flying Tumbler	229
Cuscuta californica	239	Pleione humilis	229
Dalkeith Palace flower borders	331	" lagenaria	107
Egerton House Flower Garden	29	Plant covers, Looker's	19
Fig fruiting	106	" tub, improved	445, 512,
Flower garden plans	29, 186, 207, 395, 331, 474	Planting, ornamental	47
Flower shades	478	Roller-barrow, Staplehurst	47
Force Pump, cheap	15	" watering engine	11
Fountain	129	Spilonota cynosbatella	454
Glass walls	86	Stenochlona scandens	10
Ground levelling and garden plotting	301, 323, 344, 345, 364, 365, 386, 387, 407, 426, 447	Sulphurator	87
Heating	489	Thames Embankment, planting and laying out	394
Humphrey's Clock	167	Tortrix angustiorana	296
Ice house	248	Vice-Regal Lodge	475
Leslia superbiens	167	" Flower Garden	474
Nephrolepis oxaltata	454	Wall trees, protecting	285
		Zenzera rescili	28

WEEKLY CALENDAR.

Day of Month	Day of Week.	JULY 7-13, 1870.	Average Temperature near London.			Rain in last 43 years.		Sun Risen.		Sun Sets.		Moon Rises.		Moon Sets.		Moon's Age.	Clock before Sun.	Day of Year.	
			Day.	Night.	Mean.	Days.	m.	h.	m.	h.	m.	h.	m.	h.	Days.				m.
7	TH	Royal Botanic Society's Show closes.	73.7	50.8	62.2	22	5 1/2	af	3	15	af	0	12	af	8	9	4	34	188
8	F	Birmingham Rose Show, second day.	74.0	50.9	62.0	20	55	3	14	8	40	0	12	9	10	4	44	189	
9	S	Oxford Trinity Term ends.	74.1	49.4	61.8	18	56	3	14	8	7	1	12	10	11	4	53	190	
10	SCN	4 SUNDAY AFTER TRINITY.	74.7	50.3	62.5	16	57	3	13	8	41	1	12	11	12	5	2	191	
11	M		75.4	50.7	63.0	11	58	3	13	8	21	2	12	12	13	5	10	192	
12	TU		75.9	50.5	63.2	14	59	3	12	8	13	3	12	13	15	5	18	193	
13	W		76.1	51.4	63.7	15	0	4	11	8	15	4	12	14	15	5	25	194	

From observations taken near London during the last forty-three years, the average day temperature of the week is 74.8°, and its night temperature 50.4°. The greatest heat was 92°, on the 7th, 1852; and the lowest cold 33°, on the 9th, 1863. The greatest fall of rain was 1.10 inch.

FORMING A FLOWER GARDEN.—No. 1.

THE SITE.

NATURE, amidst all the lavish wealth and marvellous variety of form and colour which she has spread around us, would appear to have attained her culminating point in the blossom of flowers. The stately timber trees, with all the dignity which their colossal proportions impart, are not so attractive, although we love to watch their storm-tossed boughs, to listen to the wind rushing through the sturdy limbs of the "brave old Oaks"

with a noise like thunder, or sighing in gentle measures among the sombre Pines, or whispering in gentlest zephyrs among the sensitive leaves of the Aspen. All these varied phases of nature influence us, and we cannot wonder at the superstitious awe and worship which the huge forms and mystic voices inspired in the earlier ages of the world, when our rude forefathers imagined they heard the voices of their gods speaking to them in wrath as they came riding on the wings of the storm, or in the more gentle accents of peace and forgiveness in periods of calm.

The elegant form of the feathery Pinus, the glossy sheen of the Laurel, the graceful Fern fronds, and a thousand other rare gems of the vegetable kingdom—all these excite our interest and command our admiration; but to none of them do we yield such entire, such hearty homage as to the flowers—the beautiful flowers. From the Rose in all her regal beauty, down to the pale Primrose or humble Violet, we love them all; in whatever form they are presented to our gaze they are always welcome. But while we admire and fully appreciate the skilfully arranged bouquet of cut flowers, or the high finish of symmetrical pot plants, it is to the parterre that we constantly return with never-ceasing interest and enjoyment; for there we find a multitude of charms, a lovely combination; earth, air, and sky all uniting to add to our pleasure. Animated nature is around us, the song of birds, the hum of insects, the bright-winged butterflies sipping rich nectar as they flit from flower to flower; the soft blue summer's sky, chequered perchance by fleecy clouds sailing lazily along—all these are there to influence and add to our enjoyment of the rich scene displayed before us. The flowers, too, present themselves in a variety of guises—in the early morning their dewy bright-coloured petals glistening in the rising sun, and at midday their gorgeous colours seeming to reflect the brightness of the sun; but in the evening, when the calm still twilight comes "stealing o'er the scene," the flower masses are most beautiful in the soft subdued light, the colours appearing to deepen and grow more lovely each moment.

Granting, then, that all this enjoyment, and very much more, may be derived from a flower garden, it is, of course, intended to imply that for it to possess such attractions, for it to become such a constant source of enjoyment all through the summer months, there are certain important points to be attended to, certain fundamental laws which cannot be broken with impunity; for if they be not strictly observed it will be vain to expect anything but disappoint-

ment and failure, no matter how neat or trim may be the keeping, or how fine and abundant the supply of plants.

In the formation and management of a flower garden the chief things necessary to be taken into consideration are the site, the design, the plants and their arrangement, and the accessories or surrounding features.

Individual taste has very much influence as regards the selection of the site of a flower garden, some preferring to have the flowers near the house, where they may be seen from the windows; while others would rather have the flower garden away in the grounds, a distinct and separate feature; and others, again, adopt a middle course, and just break the monotony of the green turf by introducing a few groups of flowers to brighten the scene without having the great bulk of flowers constantly visible. All three methods are alike commendable and useful, for it is very rarely that the same plan or mode of proceeding can be adopted in different places.

In choosing the site, therefore, the principal features of the pleasure grounds must be surveyed before a just decision can be arrived at. In villa gardens and all small places it is, as a rule, best not to fix upon any particular spot whereon to display a formal design, but to introduce an occasional bed, or group of beds, in such a manner amongst the shrubs, that although each group may be complete in itself, it may also form a connecting link with the next, and thus tend to produce a harmonious whole. Great contrasts in small places are not pleasing. This method of arrangement is best adapted to a lawn that sweeps in a semicircular form around two sides of the house, and if the lawn is enclosed and sheltered by a belt of shrubs, a walk winding among them and leading to some retired spot occupied by a fernery, will afford an agreeable promenade in the heat of summer, while the shade of the overhanging trees and the lively green and elegant forms of the Ferns will be alike attractive. A collection of healthy thriving Ferns is always interesting, and placed at the end of such a walk it would impart a grace and a meaning that nothing else could supply; it would give a charm to, and enliven, that which would otherwise be void of interest. Moreover, the Ferns would be more likely to thrive in such a position than they would be if more exposed to the sun. How frequently does this appear to be forgotten! Ferns are planted in all sorts of incongruous positions, where, tenacious of life, they linger, and put forth a few weak fronds. I have actually seen them planted on a heap formed of roots and earth standing boldly out on an open lawn!

In places of greater extent having three or four acres of lawns and pleasure grounds, a regular design may be readily introduced, and made to form an important and striking feature. Whether it will appear best near the windows of the house or away among the shrubs, must, as I have before observed, always remain a matter for individual taste to decide. If the lawn slopes gently from the mansion, and has its surface skilfully diversified by a few handsome specimens of choice shrubs so placed as to agreeably relieve without marring its expansiveness, then I think the flower garden would be far more enjoyable if away from the house in some open yet retired spot in

the shrubbery. A well-kept lawn clothed in nature's "livery of green" is always an agreeable object, soothing to the eye, and refreshing to look upon, and is a striking and important feature peculiar to the climate of our temperate zone; the flower garden in the shrubbery forms an object for a stroll, and not being constantly seen, its charms retain their freshness and attractiveness throughout the season. But if the mansion stands on a very elevated position, a terrace garden is a very appropriate and beautiful object, imparting an air of dignity and grandeur by its ample breadth, its massive colouring, and its accessories of balustrades, vases, and flights of stone steps. In forming a terrace, care should be taken to have it in good proportion to the mansion, nothing can possibly be in worse taste than a lofty imposing structure, with a narrow formal terrace garden crowded with flowers; the terrace should therefore have breadth in proportion to the height of the building it is near; and the flowers, which should be well away from the house, produce the best effect in such a position if disposed in large bold masses. A broad raised terrace walk parallel to the side of the mansion, and overlooking the flowers and the scenery beyond, forms a delightful and appropriate promenade.—EDWARD LUCKENST, *Egerton House Gardens, Kent.*

A FEW VARIETIES OF CHERRY PYRAMIDALLY TRAINED.

I HAVE several sorts of Cherries trained in the pyramidal form worked on the Mahaleb stock, and growing in a deeply-trenched, heavy, and moderately-rich loam, formerly pasture land, with a liberal mixture of brick and mortar rubbish, and a little rotten manure added. The trees were planted five years ago, and were then a good sample selected from a well-known nurseryman's stock; they have therefore arrived at a stage at which a person may easily judge of their merits, or otherwise, for this mode of training. As most of the trees have succeeded well, it may be a little guide to intending planters next autumn if I name all the sorts I grow, and give a brief description of their qualities, whether favourable or otherwise.

Adam's Crown is the first. It is a medium-sized early fruit for table use; the tree is a moderate bearer, and not a vigorous grower, but it makes a very handsome and compact pyramid.

Belle de Choisy.—A large-sized, mid-season fruit for table use; it is a moderate bearer and vigorous grower, and makes a fine tree. The fruit is very handsome.

Belle d'Orléans.—One of the best and earliest Cherries for table use; it is of good size and flavour; both in growth and productiveness it is first-rate.

Archduke.—One of the best bearers, early, and of good flavour; thin-skinned and fleshy, a good fruit for either table or kitchen use. Makes a handsome tree.

Late Duke.—A well-known and desirable Cherry for the table; large and very prolific. The growth is moderately vigorous, and it makes a pretty tree; it is generally late, coming in for use in August, but this year it promises to be earlier.

Elton.—A large, fleshy, and richly-flavoured midseason Cherry for table use. As a pyramid, it does not bear so well as some others, but it makes a good tree.

Napoléon.—Like the last named it is a sort of Bigarreau. The tree is an abundant bearer, producing large fruit of excellent flavour, which comes in about the beginning of August. It is of vigorous growth, but is not so compact as some others; it soon makes a large tree.

Circassian [Black Tartarian].—A very early, excellent-flavoured black Cherry for table use; it is in all respects a first-rate and desirable sort.

Précoce de Lyon.—This is a bad grower with me; it cankers and dies off. The tree has never ripened a fruit, so I cannot speak of the quality.

May Duke.—A well-known prolific Cherry. It succeeds extremely well as a pyramid, and is excellent in every other way. It comes in early for the dessert.

Baumann's May.—A fair-sized black Cherry for kitchen or table use. The tree is a vigorous grower and prolific. Skin of fruit thin and fleshy.

Montmorency.—The trees are moderately vigorous, with a compact habit of growth and dark green foliage; they have hitherto been shy bearers as pyramids, but the few fruit they have borne look very like an inferior sort of Morello. The fruit is late, and has an acid flavour; the trees were not until this season in a healthy state, which may account for their scanty

produce. However, the numerous fruiting spurs they are making show signs of cropping in future.

The *Flemish Cherry* makes an excellent pyramid, but it only bears sparingly. Being a late Cherry, it is worth growing for tarts or preserving; it bears a large red fruit inferior to the Morello.

Governor Wood.—This is a delicious Cherry, large and fleshy; it bears abundantly on walls, and as a pyramid it is not inferior to any of the varieties previously noticed; it is a dessert fruit.

Morello.—This is the last I have to mention; it is not often seen growing as a pyramid, but it makes the handsomest tree of any I have named, and the fruit in yield, size, and flavour is much superior to that produced by trees upon a north wall. As this Cherry differs from all others in its habit of growth, and produces its fruit upon the last year's wood instead of upon spurs, as in other varieties, a different course of treatment must be adopted for this mode of training. Very many of the shoots have only one wood bud, and that at the extremity of the shoot. If that is shortened in winter, as in other trees, the fruit is useless, and the shoot dies because it makes no foliage or wood. To obviate this a judicious system of summer pinching the young shoots must be pursued; there will then be plenty of flower buds close together, and plenty of wood buds to maintain the symmetry of the trees. The only winter pruning required will be a little thinning of the shoots to balance the action of the sap.

It is a common remark this year, that the Cherries are very much smaller than usual; this is probably owing to the dry season. We have not had more than one shower in the immediate locality since last March, although two or three miles from us frequent showers have fallen.—THOMAS RECORD, *Lillesden.*

EARLY VERSUS LATE PLANTING RIBBON BORDERS.

MR. FISH, in "Doings of the Last Week," having invited me to describe the mode of planting adopted in our large bed this season, I somewhat reluctantly do so, as circumstances led me to adopt a plan so widely different from that which he advocates, and that which, for many reasons, I would like to be able to follow. Our respective modes of operation have so little in common, that in giving a rough outline of our procedure here, I run the risk of being found fault with by almost all who have such work to do; but there may be some who may be under the necessity of adopting a plan somewhat similar, and although we are, I hope, for the well-being of flower gardening as a feature of rural embellishment, in the minority, there is no just cause or impediment why our voices should not be heard. Besides, there are, no doubt, many who will be in some measure consoled when they find that others are compelled to do as they do.

Mr. Fish throughout the long series of letters which are read with so much relish by the public, advocates late planting, and the oft-repeated warning, "wait," is without question, a prudent one. On the other hand, we practise early planting, not in every instance because it is the best, but because circumstances in a certain degree compel us to do so, and a few words on the cause of this may not be without interest. In the first place, I may explain that we suffer from want of space, and although I know how well Mr. Fish economises both that and water, yet we could not by any amount of crowding give a separate position to half the plants required here for bedding. Our flower beds have multiplied so much faster than the structures capable of accommodating plants, that we are under the necessity of planting out the majority of those for bedding direct from the cutting pans or boxes, with the exception of such subjects as are considered more choice than the rest. These are indulged with separate pots, or cared for in some other way. To make this more clear, I may mention that in addition to the large bed to which Mr. Fish alludes, and which has been often described in these pages, we have two ribbon borders, each 593 feet long, and 10 feet wide, occupying a space of more than a quarter of an acre, or equivalent to upwards of 150 circular beds, each 10 feet in diameter. It will be easily conceived that a very considerable space must be required as standing room for plants to fill these borders alone, and not having accommodation for so many we plant out many things much earlier than our neighbours, with results not always unfavourable to early planting.

To give an idea of the way we commenced planting, I may

explain that the two long borders, bounded by turf, with a broad gravel walk between them, are intersected in the middle by another walk. The loss, however, occasioned by this cross walk is not included in the measurement given above, which is simply the united length; but it will be seen that this break affords an opportunity of introducing another variety of plant, when, perhaps, there is not sufficient of one kind to make up the whole, for instance, two or more varieties of Scarlet Pelargonium or Yellow Calceolaria may be used without offence, and it is often advantageous to compare the respective merits of each kind, and when they are planted under circumstances of perfect equality, and in sufficient numbers, their general qualifications are better ascertained than from only a trial plant or two. In the case of these long borders the numbers are generally such as to show differences in mass which cannot well be distinguished in single specimens. The eye on scanning a line of 100 yards or more of the blooms of one plant is better able to discover wherein the tint of the bloom differs from that of an adjoining one, than when the comparison is made between single specimens. As a test ground, the large scale has unquestionably many advantages. The merits of a Pelargonium are generally pretty well known before it is propagated to the extent of several hundreds; still, every season brings out fresh features, or it may be different features, in each variety, so that the estimate formed of it at one time is not unlikely to be reversed at another; the experience of a series of years also enables one to weed out the indifferent kinds. I know there is an unwillingness to part with an old friend which has done good service, and yet I did so with Tom Thumb some years ago.

Omitting all notice for the present of the manner in which one large bed is planted, I will confine myself to the long ribbon borders, as they have their representatives in so many gardens. I again repeat here what I have often before stated, that I am no advocate for a great diversity of plants being used, or rather I should say, I do not approve of many distinctions in colour. Half a dozen kinds of Scarlet Pelargoniums may be all planted together without an ordinary observer noticing their differences, but pink and salmon-coloured varieties would alter the affair. Further, in ribbon-border planting, I prefer a broad band of one colour or kind of plant to very narrow lines, unless the view is confined to the end only, which happens but rarely; therefore, in most cases where flowering plants form one of the lines, I prefer to have the line broad, as few flowering plants form an unbroken line when planted in a single row and inspected at right angles to that row. Endwise most plants will do. Lobelias, Nierembergias, and Calceolarias, are about the best, but Pelargoniums seldom fill in well enough to please me; besides, a good breadth of colour shows more richness than when the space is cut up into two or three divisions. On this account I have in the present season returned with some deviations to a plan of four or five years ago, in the planting of these borders, and its simplicity is one of its best recommendations. Although the appearance is anything but inviting at the time I write (the beginning of June), the description will enable anyone to conceive what it ought to be when further advanced. These borders are straight, and with the broad walk between them, point towards the mansion, or rather from thence to another important object. As they stand clear of all shrubs or other objects, and can be inspected from the back as well as from the walk side, it has always been my custom to make both sides of each border alike, also each border like its fellow. This reduces the variety of plants used to a small number, and I do not think it is necessary to increase it; on the contrary, it would assuredly impair the effect. When planted in plain stripes we have rarely used more than four kinds of plants, and I believe on one occasion only three, including the edging plant. This season we have four, and they are of the simplest and most common kinds, yet I believe the effect will be satisfactory. The borders being 10 feet wide, we have always had ten or more rows of plants in them, and this season that number is adopted. Although one of the kinds of plants used does not confine itself to a limited space, the others are more compact. The borders have been planted thus:—An edging of *Cerastium*, followed by a band about 2½ feet wide of *Verbena pulchella*, then a single row of yellow Calceolarias; two rows of Scarlet Pelargoniums form the centre of each border; then a single row of Calceolaria, a band of *Verbena pulchella*, and the *Cerastium* as before, the whole occupying the 10-foot space. If the weather be not too dry for the Calceolaria, I expect the whole will look well when in perfection.

Now, with regard to early *versus* late planting, I expect Mr. Fish and most others will be "down upon" me for commencing so soon, yet I must not falter in telling my tale. Well, then, what do the readers of THE JOURNAL OF HORTICULTURE think of my commencing planting out on April 14th? and the Calceolarias planted that day, and on the 16th, are certainly the best we have at the present time, although they received no help or protection of any kind, being merely watered the day they were planted, and never afterwards. The weather, however, being exceedingly dry at the time, planting was discontinued after the 18th, for a week or more, but on the 29th and 30th of April, the *Verbena* was planted, the planting of the Calceolarias having been finished in the interval. On April 30th about four hundred Pelargoniums were planted out, and no protection of any kind given. The frosts that followed on May 3rd and 4th, of course stopped the planting of tender plants, and the Pelargoniums suffered, but none were killed, and now they are not the least promising of the Pelargoniums we have bedded out.

The above is, no doubt, an extreme case, and I do not state it with the view of encouraging early planting, but under circumstances similar to those under which we were placed, early planting may be adopted in preference to the plants' suffering from confinement in their winter quarters. It must not be supposed that we are exempt from the evils of frosty nights and cold easterly winds, for on the night of May 2—3 I put a basin with water in it upon a grass plot near my cottage overnight, and the next morning it was so frozen that the basin could be turned upside down without the water running out, and on the next night the frost was about the same. It was, however, the extreme dryness which enabled plants to withstand the cold, and these Pelargoniums did so. I hope at some future time to report their condition as compared with the same kind planted later, for although these were planted in April, we did not finish planting out Pelargoniums till June 4th. The other conditions, however, relative to planting are of so conflicting a nature, especially with regard to Pelargoniums, that they cannot well be all explained in one paper; but in a subsequent one I hope to enter more fully into the causes which sometimes render early planting preferable to waiting so late as usual.—J. ROBINSON.

(To be continued.)

PRUNING ORNAMENTAL TREES AND SHRUBS.

No. 3.

Section II.—In this section we have trees of a different type from those in Section I., for, unlike the latter, the leaders may be more than one, and yet the form essential to a good specimen will be preserved, whether the form of the tree is conical as with the Chinese Juniper, or spreading as with the Hemlock Spruce and common Yew. They also differ from Section I. in this respect—good specimens may be obtained from cuttings or layers, and grafts; but there is no question that the healthiest, freest in growth, and best-formed are trees raised from seed. Such in all cases are to be preferred to those from cuttings and grafts. Indeed, some of them so propagated are not suitable for single specimens, as the *Cupressus Lambertiana* (macrocarpa), *C. Lawsoniana*—I know cuttings root freely enough, but we expect something more than a bush from this graceful tree—all the genus *Taxus* when practicable, *Thuja gigantea*, *T. Lobbi*, *T. occidentalis*, and *T. orientalis*.

The trees or shrubs constituting this section are in habit erect or conical, spreading or diffuse, a few being pendulous, and one or two are procumbent. Of those which are erect, conical, or pyramidal in habit I may name *Chamaecyparis sphaeroidea*, *C. thurifera*; *Cupressus Lambertiana*, *C. Lawsoniana*; *Juniperus chinensis*, *J. communis*, *J. hibernica*, *J. virginiana* (Red Cedar); *Retinospora pisifera*, *R. plumosa*, *R. obtusa*; *Taxodium distichum*, and its variety *fastigiatum*, the type of an upright-growing tree; *Taxus adpressa*, *T. adpressa stricta*, *T. baccata pyramidalis*, *T. elegantissima*, *T. erecta*, *T. fastigiatata*; *Thujaopsis borealis*; *Thuja gigantea*, *T. Lobbi*, *T. occidentalis*, *T. plicata* and var. *Warreana*, *T. orientalis* and var. *elegantissima* and *stricta*.

The spreading are *Abies canadensis*, *A. Albertiana*, *Taxus baccata* and its variety *fructu-luteo*, *T. Washingtoni*, and *Thujaopsis dolabrata*.

The pendulous are represented by *Cupressus funebris* (not hardy, or only so in warm sheltered situations), *Taxus Dovastoni*, and *Thujaopsis Standishii*.

The trailing are represented by *Juniperus prostrata*.

In proceeding to prune the conical or pyramidal-habited kinds, it will be necessary to keep a strict eye on the upper part of the plant, for, as not infrequently happens, there may be a number of upright shoots that start from a part almost parallel with the leader. These must be shortened so that greater vigour may be thrown into the leader, in order that it may preserve its superiority. Indeed, it is of great importance that the tree be kept to one leader, for if more than one be allowed, the subject, though the pyramidal form may for a time be secured, will ultimately open, and have anything but a good appearance. Tying the branches together is but a bad remedy for open tops or heads. This evil might be prevented by beginning in time with the pruning knife. What I advise is keeping all trees to one leader by cutting back each of the side shoots as, from their strength, are likely to interfere with the leading shoot, the leaders of all such shoots being taken off to some of the smaller ramifications at the base, which will be necessary for clothing the stem and to give extension outwards.

Sometimes strong shoots arise from various parts of the tree; they can only cause an irregularity in the growth, and should be cut back so as to preserve the required form, and yet the pruning must be of such a nature that the branch operated on will be weakened, and the sap it had before appropriated be diverted from it to the weaker parts of the tree. In pruning to stop excessive vigour in any part, the strongest and longest parts must be those removed, for the channels being wider, the sap flows more freely into them; therefore when they are removed the sap does not enter the smaller shoots in any greater quantity, or but slightly so, than when the strong parts are present; hence a quantity of sap is liberated that must find its way to other parts of the tree, and the subject is not slow in meeting this supply by putting out fresh shoots, or those already in existence receive a greater amount of support, consequently are invigorated. In like manner the weak and thin sides or parts of a tree may be rendered stronger by thinning out and shortening the strong shoots; and when this is the object the pruning should be done when the plants have commenced growth and are somewhat advanced; then the sap will be appropriated by the parts growing and not pruned.

It not uncommonly occurs that trees of some kinds will have a sort of divided leader, two three, or more shoots starting from one point, and none taking a direction well calculated to form a good leader. In cases of this kind one of the most vigorous and upright shoots must receive every encouragement, by the upright growths of the others being cut off, but leaving a sufficient number of the side shoots from them for furnishing the tree in that part. If the leader cannot be reduced to one without making an opening on one side, or causing a deviation from the upright direction, it is better to have more than one leader, if it be only for a time; that ultimately intended to have the sole leadership being encouraged by cutting away such parts of the others as can be dispensed with without injury to the rest of the tree, always keeping in view the symmetry and character of the subject.

In some cases two, three, or more leaders have been formed, and the tree, allowed to attain a considerable height and size, has already begun to open at the top. This is very commonly the case with the Arbor-Vitæ. Little can be done in cases of this kind: but by thinning-out the shoots where they are very close together, without making the tree too open, the growth of the latter may be increased in the direction of parts that are open. In a like manner the height of the tree may be added to by thinning-out the heavy upper parts, and this being done after the tree has commenced growth, the lower branches, which are seldom so strong as the upper branches, will receive greater support and become more vigorous. It is well in all cases to secure as nearly as can be equal vigour in every part of the tree. It will be attained by thinning-out the strongest parts when growth has begun, and not interfering with the weak. Loose, long, or irregular growths should be cut closely in, but this must be done before they become old, or ugly gaps will be formed, which it may not be practicable for a long time to fill.

The spreading-growing trees require pruning of an entirely different kind. It is well if they can be kept to one leader, and as that may be done until the trees are of considerable size, it is advisable to remove all the leaders but one; and any branches that take an upright course, and are on that account likely to attract more than their share of the sap and so become excessively vigorous, should be cut clean away; or where that cannot be done without making an opening, cut off the

extremity of the upright-growing branch to where more horizontal branches diverge.

The pruning of the spreading kinds of trees, indeed of all trees, must be done in such a manner that no one can tell in the course of a year or two that the pruning-knife or saw has been used. This can only be effected by cutting close to another shoot or branch, which, though not intended to take the place of the first one, will give all the appearance of a close growth at that part. If this cannot be done the pruning has been deferred too long, and is much better left alone. How often do we see trees divested of great limbs, making gaps which no succeeding growth will fill up; the lower branches cut off without any regard to clothing the trunk; and strong branches shortened so as to leave nothing but a naked part, often several feet in length, from which no shoots are produced in some kinds of trees, whilst in others is produced a tuft of strong shoots which take an upright direction, and are a greater eyesore than the parts first removed. Such is not pruning but maltreatment.

Some of the spreading kinds make excellent close pyramids, bushes, or hedges, the Yew being the best of all for these purposes. It submits to pruning better than any other tree, and may be cut at any age or size, and it will push again from every part. On that account it is much in request where a close verdant screen is required, and also for gardens where bushes of evergreens are required not to exceed a certain size, and to be kept of a certain form. The pruning of such subjects is best done in spring before growth takes place. Whether little or much cutting-back is required, there can be no question that spring is the best time, as there is then every chance of good growth and closeness of foliage; besides, the subjects have a more feathery appearance than when the pruning is performed after the growths are completed, and if any irregular growths are made it is easy to remove them after that time. If a close wall-like screen be wanted, of course the cutting must be done after the growth is complete, or in July.

The American and Chinese Arbor-Vitæ are also used for screens. I think they are best cut-in during the spring, as we then secure the foliage of the year, instead of allowing it to be produced and then cutting off the greater part of it. The Irish Yew also makes a good screen, and needs very little trimming; it is of such dense growth, that no other pruning than that of the knife is wanted. Its only drawback is that when of good size the upper part has a tendency to open, but that may be remedied by not allowing the side shoots to grow more than a few inches before they are shortened. This attended to, it makes one of the very best screens, and requires little care. The Irish Yew, it should here be stated, though it grows upright, ought not to be trained as a cone or pyramid; that cannot be done without pursuing a system of pruning that must very much limit the proportions of the tree and make it narrow and formal, therefore the branches may open, and each will be feathered throughout its length. Irregularities of growth will, of course, need to be cut out, a good specimen being the object in view, and this secured, the trees will be quite a feature from their fastigate character. Tied-in as the branches sometimes are, the trees may serve for a time. As cones of 6 or more feet in height, the Irish Yew is unequalled; but if it is intended to show at any future time in character, the tying only destroys the small twigs that would form on the upright branches, and these are consequently bare in the centre.—G. ABBEX.

OPENING GARDENS TO THE PUBLIC.

It singularly happens that I have been frequently on the point of writing to THE JOURNAL OF HORTICULTURE, holding forth the gardens of Elvaston Castle as an example to the way in which such gardens should be opened to the public; for, some years ago, I went with some friends, during the life of the late Lord Harrington, to see these celebrated evergreens, and we were then admitted by printed tickets—I think the price was 2s. 6d. to admit a party of four—the produce of which was appropriated to the support of the Derby Infirmary; “no fee to be given to the gardener.” If such a plan were adopted at such places as Chatsworth, Trentham, and Enville, and special days of the week appointed, what an excellent arrangement it would be. Valuable charities would be supported, visitors would know exactly what they had to pay, and neither the privacy of the owner nor the business of the gardener would be interrupted on the other days. The arrangements might be made known to the inn-keepers in the neighbourhood, and

the information would soon spread among those interested in such places. The charge for a single admission might be 1s., and for cards admitting four persons 2s. 6d.; the expenses of the men to show visitors over the grounds to be deducted from the general receipts, and the men to be strictly prohibited from receiving gratuities.—Hortator.

LUXURIANT FOLIAGE, BUT NO FRUIT.

"In the winter of 1865-6 you supplied me with a number of pyramid fruit trees—Apples, Pears, and Plums, as well as Currants. These have, with the exception of a few of the Pear trees, thriven grandly as far as wood and foliage go; but we obtain scarcely any fruit. Last year we had a few Apples (Domino and Warner's King), and about half a dozen Pears of various sorts. Not a Plum has yet formed. Again, this year there are some Dominos, and a very few of other sorts, but no Pears. The trees have been carefully treated—planted, pruned, &c., in accordance with the instructions given in Rivers's 'Miniature Fruit Garden'—a good authority, I presume.

"The soil is a fair loam, on deep gravel and rubble. The situation high, yet sheltered, and being high and on gravel, the garden is very much parched in long droughts like the present. This affects Strawberries and many flowers, which need diligent watering. All kinds of fruit trees and bushes, however, thrive in growth, while they bear little or no fruit. This is, perhaps, more strikingly the case with Raspberries than with any other. The canes are each year most vigorous, the foliage luxuriant and fresh throughout the season, and the show of blossom magnificent. The blossoms, however, prove universally blind, and never set. Can you suggest where the fault lies? Is it likely that the situation is too dry? But, if so, would not the foliage tell the same tale?

"I have some thoughts of removing the fruit trees to another garden in a lower situation, where the loam is somewhat deeper and the subsoil less porous. In this lower garden vegetables, to which at present it is exclusively devoted, are grown with good success. May I hope to find advantage in this removal? It is not intended purely for the sake of the fruit trees, but with a view to adding the ground to the lawn and flower garden.—E. H."

The above letter, just received, describes in forcible language the state of many gardens and individual fruit trees—trees and plants growing luxuriantly, and bearing little or no fruit. I believe, in the majority of cases, keeping the land loose by digging and forking is the cause of failure.

Some years since I was sent for by a gentleman to inspect his Peach trees (standards planted out in a border of his orchard house), which he told me always cast their fruit. No trees could look better; they were as clean and healthy as could be wished. After asking his gardener all the questions I could think of as to the management, and receiving satisfactory replies, I all at once thought of the soil, stamping upon which with my heel I found it almost as light as a feather bed. "How is this?" I asked, knowing the gardener had often been to see my trees, and that he knew the borders had never been disturbed since the houses were built. "Oh," he said, "Mrs. — will have winter salads grown here." "Give my compliments then," I replied, "and say she must not expect Peaches." The border was made solid and kept so, and there was a full crop the next season. The fact is not so easy of explanation as some people think, but fruit trees like solid soil, not loose.

That digging amongst such plants as Raspberries and Strawberries must be a stupid practice is patent on the least consideration. Why manure a piece of land and then destroy the roots seeking to occupy it? When the roots have been mutilated, how can the plant be expected to bear drought or carry fruit? I saw at Berry Hill, near Mansfield, the other day, a large bed of Hautbois Strawberries with as much fruit as any common variety might be expected to carry, and this on light land. Other varieties were loaded with the largest crop I ever saw in my life. I asked Mr. Cope, the gardener, how they had been managed. He said as soon as the crop was gathered all weeds, runners, and dead foliage had been removed, and the ground between the rows covered with a very thick dressing of manure. The rows had also been watered two or three times with manure water. The plants were then encouraged to make a strong healthy growth in the autumn. The whole land was full of roots, and covered, as the surface was with the remains of the manure, the plants had not suffered from want of rain, whilst Strawberries in the neighbourhood, on better soil, which had been dug in the winter, were burning

up. Ram the soil hard whilst dry when potting Vines, Peaches, or any other fruit trees, keep fruit-tree borders solid and mulched with manure, and there will be fewer failures in fruit culture.—J. R. PEARSON, *Chilwell*.

ROYAL BOTANIC SOCIETY.

THE July Show of this Society opened yesterday, and will close to-day. The large tent, which in former years was filled with fine specimen plants, chiefly stove and greenhouse, is on this occasion principally occupied by table decorations, bouquets, and hanging baskets, to the exclusion of all other examples of horticultural skill. The substitution has been too much in one direction, and it is not altogether satisfactory; the place is not suited for such a display, and such a display without fine specimen plants is scarcely what we look for as an encouragement to horticultural skill; an encouragement to artistic arrangements it undoubtedly is, but that, though it should not be lost sight of by a horticultural society, is less to be considered by it than excellence of cultivation. The artist wants the graceful in form, the beautiful in colour, and whether the plants be well-grown or ill-grown matters little to him; he can skip from flower to flower till he has gathered sufficient for his purpose—the wreath of to-day that will be faded to-morrow, and lost for ever if not depicted upon his canvas.

Horticulturally, then, fruit is the great feature, and of that there is not very much; it is very good without being super-excellent, and there is none of it bad.

The best collection of fruit arranged as a dessert comes from Mr. Johnson, gardener to the Marquis of Aylesbury, Savernake, and consists of two Queen Pine Apples, Black Hamburg and Muscat Grapes, Bellegarde and Tete de Vents Peaches, Elnage and Violette Hative Nectarines, two Melons, Black Tartarian and May Duke Cherries, two kinds of Strawberries, and White Currants. Mr. Bannerman, Lord Bagot's gardener, at Rugeley, is second with excellent Pines, Grapes, Peaches and Nectarines, Cherries, Strawberries, and Melons. Mr. Clark, gardener to Earl Cowper, Brockett Hall, is third, and Mr. Carr fourth.

The best six dishes of out-door fruits consist of Gooseberries, Currants (White and Red), Cherries, and Strawberries, from Mr. Gardiner, gardener to P. Shirley, Esq., Eaitington Park, Stratford-on-Avon. Mr. Clark, gardener to Earl Cowper, is second; and Mr. Harvey, gardener to B. Wroughton, Esq., third.

Pine Apples are but poorly represented as regards number, but are generally good. The best Queen comes from Mr. Acres, gardener to Mr. Copestake, Highgate, and is a splendid fruit of 6 lbs.; the second best, weighing 4 lbs. 10 ozs., is from R. H. Smith, Esq., Calderstone, Liverpool; and the third best is Moscow Queen, from Mr. Gardiner. Mr. Miles, gardener to Lord Carrington, Wycombe Abbey; and Mr. A. Wright, gardener to C. H. Roberts, Esq., Regent's Park, also send very good fruit of the same variety. For the best Pine of any kind, Mr. C. Penford, gardener to Earl Radnor, Longford Castle, Wilts, is first with Providence; Mr. Bertram, gardener to R. T. Crawshaw, Esq., Cyfarthfa Castle, Merthyr Tydvil, being second with the same kind weighing 8 lbs. 1 oz., but not quite ripe at the top. Mr. Acres is third, with a finely-ripened 5-lb. Queen; and Mr. Miles and Mr. Ward fourth, the former with an 8-lb. Providence, and the latter with a Smooth Cayenne of 5½ lbs. In the miscellaneous class the first prize is awarded to Mr. H. Harvey, gardener to B. Wroughton, Esq., Woolley Park, for three Queens fifteen months from the sneaker, weighing collectively 11½ lbs. The best pair of Pine Apples in pots come from Mr. Miles, Lord Carrington's gardener, and are of the Queen variety, bearing fruit averaging about 4 lbs. The gardener to Mr. Flower, Tooting Common, comes second with well-fruited plants of the same variety, and Mr. Hepper, gardener to J. Walmsley, Esq., The Elms, Acton, is third.

Melons are but few. The best and second best in the green-fleshed class are small fruit of Marquis of Ailsa and Dr. Hogg from Mr. Crane and Mr. Gardiner respectively. Scarlet Gem and Meredith's Hybrid Cashmere take the prizes in the scarlet-fleshed class, the one coming from Mr. Cross, gardener to Sir F. Goldsmid, Burt, the other from Mr. Burnett, gardener to Mrs. Hope, The Deepdene, Dorking.

Of Grapes there is but a small show; there are competitors enough to take all the prizes, and only a few are left "out in the cold." The best 12-lb. basket of Black Grapes comes from Mr. Ward, gardener to T. N. Miller, Esq., who has finely coloured Black Hamburg. Mr. Davis, Whetstone, is second, and Messrs. Standish & Co. third with Royal Ascot. The best baskets of White Grapes (Muscats), are from Mr. Osborn, Finchley, and Mr. Davis.

Of Black Hamburgs splendid bunches in size, berry, and colour from Mr. Penford, Earl Radnor's, are first, and fine bunches from Mr. Bannerman second, Mr. Davis being third.

Muscats from Mr. Pizzev and Mr. Davis, though the best, are not ripe enough. The former has also a first prize for an excellent bunch of Royal Muscadine in the class for any other kind. Mr. Penford is second with good bunches of Black Prince.

Of Peaches Mr. Lynn, gardener to Lord Boston, Hedsor, and Mr. Miller, Combe Abbey, send fine dishes of Grosse Mignonne, Royal George, and Violette Hative, and take first and second prizes. For Nectarines Mr. Miller and Mr. Lynn are respectively first and second, the former with very fine examples of Violette Hative and Elnage.

For Cherries Mr. Miles, gardener to Lord Carrington, is first with beautiful fruit of Bigarreau Napoléon; Mr. Widdowson, Chorley Wood House, being second, and Mr. Ross third. For Black kinds Mr. Pettie is first with Black Tartarian, and Mr. Miles second with May Duke.

Only one dish of Plums is shown, and that is Orleans, by Mr. Miles, and excellent they are. The same exhibitor also sends the best four dishes of Strawberries, magnificent fruit of Admiral Dundas, Dr. Hogg, Sir C. Napier, and Mr. Radclyffe, the first two being the finest. Mr. Widdowson is second, Mr. Douglas, Loxford Hall, third, both with excellent dishes. Mr. Miles also sends an excellent dish of Bietou Pine.

Of table decorations there is a tolerably extensive display, as well as of bouquets, hanging baskets, and Fern cases. Some are tasteful enough, but none very remarkable. Miss E. Blair, New Wandsworth, was awarded H.R.H. Princess Mary's gold medal for a group of plants and flowers, and arranged for table decoration. Mrs. Green, Crawford Street, Grosvenor Square, and Misses Harris & Hassard were also successful exhibitors in several of the classes.

Groups of new and rare plants come from Messrs. Veitch and Mr. Williams; of bedding and other plants from Messrs. Lee and E. G. Henderson; and plant cases, horticultural implements, &c., from Messrs. A. Henderson & Co., Deane & Co., and others.

Her Royal Highness the Princess Mary distributed the ladies' prizes on the first day of the Show.

AMERICAN POTATOES.

I HAVE often seen in your Journal different accounts about the new sorts of American Potatoes, but I have never seen where they have been dug earlier than I might have dug them if I had liked. I left them, however, until they were dead ripe. We should have had much finer Potatoes had there been rain, but I am sorry to say there has not been any rain here for the last eight or nine weeks, and then for only about three hours, and there has not been four hours' rain for this last four months. The Potatoes were as follows:—

Climax, planted February 28th, three Potatoes cut into fifteen sets. Fit to dig June 7th; dug June 30th; weight 6 lbs. 5 ozs. Early Rose, planted February 28th, six Potatoes cut into thirty-eight sets. Fit to dig June 16th; dug June 30th; weight 14½ lbs. On the same border was Myatt's Ashleaf, planted the same day and dug May 20th. On another border with the same aspect was Breesee's Prolific, planted March 15th, but it is quite green and a long way from being fit, but when I dig up the tubers I will state how they turn out. Breesee's King of the Earlies, planted March 15th, was fit to dig June 7th, and was dug June 30th. Two Potatoes had been cut into six sets. Weight of produce 2½ lbs. Myatt's Ashleaf, planted March 15th, was dug June 1st; the sample was not large but beautiful, clear, and clean. The earliest of any of the American sorts, you can see, is the King of the Earlies, and it is the smallest cropper, but I think none so early as Myatt's. I dug up some Potatoes out of doors as early as May 15th; but they are a round sort taken when half ripe for market, not a good sort for table. The variety is here called the French White, but I do not know if the name is correct.

There is a beautiful specimen of the *Agave americana* throwing up a flower spike in a gentleman's garden by the side of the road. The place is called The Grange. The spike is now about 6 feet in height. American Aloes are quite hardy here; that referred to has had no covering to my knowledge this winter.—*J. Dawson, Gardener to W. H. Smithard, Esq., Somerville, Guernsey.*

NEW BOOK.

Handbook of the Sulphur Cure as applicable to the Vine Disease in America. By W. J. FLAGG. New York: Harper and Brothers.

ONE of the most decisive examples of needless book-making we ever saw. The whole of its practical contents may be comprised in one sentence—Apply flowers of sulphur either by the aid of a pair of sulphurator-bellows or a dredger.

WEAR AND TEAR OF THE WORLD.—In a paper in the *Bulletin de la Société Vaudoise*, No. 62, Dr. C. Nicati gives a *résumé* of various researches respecting the peculiar red snow which occasionally falls in the Grisons. Some of this snow fell, mingled with common snow and rain, during a violent storm from the south-west on the morning of January 15th, 1867, in various places. The chemical analysis of the melted snow demonstrated the presence of minute quantities of sulphate of lime or gypsum, sulphate of magnesia, organic matters, chlorine, and iron;

and microscopic examination detected vegetable fibre, pollen, spores, with here and there diatoms and small crystals. The colour varies from brick red to a pale yellow. This snow is quite distinct from the red snow of the upper Alpine regions, which owes its colour to the presence of the minute plant *Protococcus nivalis*. After discussing various theories respecting its origin, Dr. Killias expressed his opinion that it is the dust of the Desert of Sahara, transported by a sirocco, which gives the colour to the snow of the Grisons. Dr. Nicati gives many interesting particulars, with analyses, of the Algerian sirocco dust, and of the mud-rain in Naples and Sicily; and Professor C. Cramer states that he has discovered, both in the sand of the Sahara and in the red snow of the Grisons, particles of vegetable organisms (especially polythalamia) and minute fragments of animal origin, such as wool, hair, &c. He considers the presence of gypsum in the red snow an incontestable proof of its containing matter conveyed from the Desert of Sahara.—(From our weekly contemporary, *Nature*.)

GARDENERS' ROYAL BENEVOLENT INSTITUTION.

ON the 29th ult. the twenty-seventh anniversary festival of the above Institution was held at the London Tavern, the Rt. Hon. The Earl of Derby in the chair. His Highness The Nawab Nizam of Bengal, attended by Colonel Layard, honoured the Institution with his presence upon this occasion. After the usual loyal and patriotic toasts had been proposed and duly received, Lord Derby proceeded to the toast of the evening, "Success to the Gardeners' Royal Benevolent Institution." He said that he should propose that which was the toast of the evening in very few words, for whatever they might agree upon, or whatever they might disagree upon, there was one thing in their hearts in which they would all be of one mind, and that was that the sight of flowers, accompanied by music, was much more suitable to after-dinner hours, and more conducive to enjoyment than anything else. The Institution at the end of 1869 carried over a balance of £1400, and had invested in the funds nearly £8000, the number of pensioners at the present time being fifty-four. Since the establishment of the Institution upwards of £15,000 had been expended in giving relief in accordance with the conditions laid down by their rules. So far, the position of the Society had been one of steady and unvaried prosperity, not, indeed, so much as they might have hoped or desired, but still, upon the whole, satisfactory. Their chief difficulty had been that, extending their operations as they did over the whole of the country, the list of subscribers still remained much smaller than they wished to see it; but certainly when he looked at the number of persons employed in the profession of horticulture, and at the support which had been given by the leading men in the profession—men known all over England, he could not help thinking that with better organisation they might contrive to extend their operations far beyond their present range. He thought there was no need to argue in defence of the principle on which the Institution was organised, that principle being one partly of charity and partly of insurance. Nearly every occupation existing in this country had found it to their interest to adopt this principle. Their rule for giving assistance was, first, that the fact of the distress should be proved, next that the character of the claimant should be ascertained, and then, without absolutely excluding non-subscribers, preference should be given to those who had during fifteen years contributed to the funds of the Institution. This preference was only fair, because, in point of fact, those whom they were assisting were merely receiving back that which they had subscribed in days of prosperity. He conceived that this kind of charity was the best for several reasons; first, because persons who follow the same business have means of ascertaining the condition of the applicant for relief which others do not possess, and thus there is a check upon imposture; and next, because the fact of previous subscription excludes mere recklessness and improvidence, and so calls into play those principles which are the most pure. He ventured to think that if every trade and every profession had an institution such as theirs, and if it became a sort of social law that every member of every trade should subscribe to it, a great blow would be struck at that pauperism which now affects England so much, and we should get rid of the increasing number of cases of pitiable and preventible misfortune. He need hardly say that of all those—and, unhappily, there are many—who come to a state of destitution in this country, none are so much to be pitied as those who previously held a good position, because the better their position was in former days, the more they shrink from contact with the lowest and coarsest of those among whom pauperism exists. In the present day we live too fast, and too often we live in such masses that hardly anybody would like to say what his next neighbour was; but those who are engaged in the same occupation should hold it a duty to assist their poorer brethren. It gave him great pleasure to preside over a gathering such as that, when the members of the same trade were brought together, not in professional rivalry and antagonism, but with a common desire to assist the afflicted. He often thought that a good garden was the prettiest thing on the earth. A man might walk through a picture gallery and see a

great picture or statue, and yet it would only create within him a feeling of admiration; but you might take the dullest lout out of the streets, or the most savage Arab who ever slept under a dry arch, put him amongst flowers and trees—things which appeal to something in the man that awakens within him a consciousness of his duty to his Creator. He believed that anything which tended to refine the popular taste deserved encouragement by the nation.

Mr. R. Garth, Q.C., proposed the health of the noble Chairman in terms the most eloquent.

The Earl of Derby, in responding, announced that H.S.H. the Prince of Teck would honour the Institution with his presence at the next annual festival.

Mr. Donald Nicoll proposed the health of the Vice-President of the Institution, and Mr. J. J. Mechi responded in suitable terms.

The Secretary announced the amount of the subscriptions premised at the festival to be upwards of £500.

The Chairman then proposed the health of the Secretary, which Mr. Cutler briefly acknowledged.

Groups of plants for the decoration of the room were contributed by Messrs. Veitch, Lee, B. S. Williams, Turner, and Carter & Co.

THE NEW ROSES

AT THE ROYAL HORTICULTURAL SOCIETY'S SHOW.

As the report already given has entered largely into the general character of the Show and named the successful competitors, I shall confine myself to the new Roses—viz., those of 1868 and 1869, not specifying the stands, but picking them out here and there.

Edouard Morren was again largely exhibited. My opinion of it remains as it has always been; it is a somewhat coarse flower, and inclined, like General Washington, to shew a green eye. Probably not one bloom in a dozen would be fit to put into a stand of twelve, but when caught it will grace any stand. Reine Blanche, as shown here and at the Palace, was a great deal too rough for exhibition, and a good white Rose is still a desideratum. Nardy Freres is a good Rose, as I have said before, somewhat dull in colour, but we must wait for another season before deciding finally as to its position. Madame Clert is a very pretty bright pink flower of good shape; and Thyra Hammerich a very pretty blush white Rose with shell-like petals, formed somewhat in the style of Baronne Prevost, only a little more cupped—very pretty indeed at times. Souvenir le Monsieur Poiteau has come very rough this season where I have seen it, but its colour will always ensure it a welcome. Mademoiselle Eugénie Verdier is a very pretty Rose, and likely to be an acquisition. Of Clémence Raonx a box was exhibited by Messrs. Lee, and if constant to that state it was decidedly a novelty, being of a light blush ground distinctly margined with pink. Monsieur Journeaux is of a very peculiar shade of colour—reddish scarlet with a purplish tinge through it, good form and large; this struck me as a very desirable Rose. Marquise de Mortemart is an undoubtedly good Rose in a section where good flowers are much wanted, blush white; Madame Creyton, a fair Rose; Devienne Lamy, again shown in good condition; Henri Ledechaux, a fine carmine Rose, of which I have again to say that it deserves to be grown more than it has been; Julie Tonvais, a very curious Rose with large petals, almost reminding one of a Tea, but I think one not likely to be of much use; Emilie Hansburg, a prettily-shaped pale rose, and with imbricated petals—a flower deserving of being grown if its habit be good, which it seemed to be; Madame Joséphine Guyot, a very pretty and well-shaped Rose, which I cannot find in any catalogue; Victor Trouillard, too rough; Victor le Bihan, beautiful bright rosy carmine; Dupuy-Jamain, of which I have again to repeat what I said, that it is a beautiful carmine Rose well worthy of cultivation; André Fresnoy, not very remarkable as shown. The same may be said of Ferdinand de Lesseps and of Comtesse d'Oxford.

It will be seen from the above that comparatively few of the new Roses of this season have been exhibited—not one of the Teas; one Noisette, Reine d'Or, at the Crystal Palace; and not above five or six of the Hybrid Perpetuals. This is to be accounted for by the fact that nurserymen are busy propagating them, and hence cannot afford to allow their plants to grow on for exhibition. Of those of 1868 the following have, I think, made good their claim to remain amongst our favourites—Devienne Lamy, Dupuy-Jamain, Edouard Morren, Henri Ledechaux, Madame Creyton, Marquise de Mortemart, Monsieur Journeaux, Souvenir de Mons. Poiteau, Thyra Hammerich, and Victor le Bihan.

I have bloomed some of the new Tea Roses, and am inclined to think that we have some good kinds amongst them. Chamois is rightly named, but there is too little of it. Madame Ducher has a good deal of aueology, as I have it, with Devoniensis, and is a very fine Rose. Lamarque a fleur jaunes promises to be a good yellow climbing Rose. Unique is a very remarkable-looking flower, shaped like a Tulip, but I wait for another bloom before deciding. But to my mind the finest flower of the season, as far as I can see, and from all, too, that I heard in Paris, is Louis Van Houtte, raised by my old friend Lacharme, one of the most conscientious of our Rose raisers in France, and already dear to all lovers of the Rose by François Lacharme. Louis Van Houtte is likely, I think, to uphold his fame; it is of the shape of the old Cabbage Rose and of that fine Rose François Treyve; it has also the fine perfume of the old Cabbage; in colour it is like

Charles Lefebvre when it comes dark, approaching at times to that of Prince Camille de Rohan. The habit of the plant is vigorous, and altogether I am inclined to consider it the best Rose of the season. There is another Rose whose position is now so well established that it is not needful to say much of it, but I question if at the Show on June 29th there was one Rose which sooner caught the eye and held captive the beholder than Duke of Edinburgh. Mr. George Paul may well be congratulated on having sent out this fine English Rose, for in brilliancy of colour it is unsurpassed, while its fine habit gives it also a claim which many dark Roses do not possess.—D., Deal.

STRAWBERRIES NOT FRUITING.

THE soil for "Sir Harry" Strawberry has been highly manured, and is on a generous clay, but we have hitherto failed in procuring anything beyond most luxuriant growth and fine dark foliage—no fruit at all worth speaking of, although the bed is a large one. What would be the most judicious mode of treating this bed in order to insure fruit next year? I should add that this is the third year since the bed was planted.—F. U. S.

[Perhaps your instance of Sir Harry not fruiting, but growing so luxuriantly, may be partly owing to the rich manuring, and the strong rich soil in which the plants are growing. I have known cases of Strawberry plants taken from a prolific stock yielding but little fruit, owing to the over-luxuriance, of the plants, arising from rich manuring, and having the plants so close together in the bed that the sun had little power to ripen the fruit buds, and then the following year there was vigorous growth and only a sprinkling of puny flowers, followed by few and small fruit for the kind. If you determine to keep this bed of Sir Harry, and give the plants another chance, then I should advise the following treatment.]

As soon as the fruit is gathered I would remove all the runners, but keep none. In your soil there must no mowing off nor cutting the leaves, but I would go over every plant, and cut out with a sharp knife all the little pieces with the smallest buds from each plant, or rather stool, leaving to each three or four with the plumpest buds, and all the leaves attached to them. The sun and air will have more power to act on such thinned-out stools. By this thinning-out mode and surface-manuring, I have known Strawberries continued in prolific bearing for many years, and the crops were nearly as good as from those fresh planted every two or three years. In your case, as the plants seem very luxuriant, I would not manure with decomposed dung, but would merely place a little longish litter among and round the stools, to protect the buds from the frosts of winter and spring. If your plants have come originally from a prolific stock, with such treatment you would probably have a fair supply of fruit the next summer.

But though I should be glad if you adopted the above plan, and informed us of the results this time next year, for the benefit of all concerned, still as you state that you have had scarcely any fruit from these luxuriant plants for three years, unless the ground is of no consequence to you, I would advise you to have only a part of your bed so treated, and plant another bed with young plants obtained elsewhere from a prolific stock. I have proved over and over again that the above plan will often make unfruitful plants fruitful, but I have also proved, at least to my own satisfaction, that there are Strawberry plants, and not confined to this or that kind, so naturally sterile that no treatment will make them prolific. And what is more, I have found, and more especially of late years, from my attention being turned more to the matter, that the runners taken again and again from such plants continue sterile, though as an experiment I have repeated the process from year to year with Keens' Seedling, British Queen, Elton, and even Sir Harry. Such facts have so settled this matter down into a conviction, that had I time I would clear out every such sterile plant that did not show bloom the first year after planting. Unless taken as a runner from a prolific plant, there is the risk that it never becomes prolific at all, and there is a greater risk that from such plants you continue the sterility, as the sterile plants are always the most luxuriant, the most plentifully supplied with strong, fine-looking runners, and, therefore, are more likely to be selected for pricking out and planting than the smaller runners from prolific plants. Such plants, besides their excessive luxuriance, may also be distinguished, as already stated, by the number and strength of the runners, and by the buds of plants and runners being long and sharp-pointed, instead of more flat and obtuse. I have no desire to go beyond my own observations and experience, but I would not know-

ingly plant runners from such plants, and, of course, would not wish anyone else to do so except as an experiment. I have had plenty of evidence that such sterile plants are too likely to continue to produce sterile plants for many generations.

The evidence as to restoring plants taken from fertile parents that have become sterile from over-luxuriance or want of sun and air, is, so far as my own experience and observation go, more conflicting. Sometimes the remedy alluded to above has succeeded, at other times it has not, as there is too great a tendency in plants as well as in man to go on in a bad course when once it is fairly commenced.

This season I have been told of seven or eight fine-looking beds of Strawberries that did not suffer especially from the drought, and that scarcely yielded a bloom. I think it is three or four summers since I stated how I was invited to look at a large bed of Strawberry plants, chiefly Keens' Seedling, and nothing could look better at a distance. The flower trusses were just bursting the buds of my own at home. In this fine-looking bed there was not a single fertile bud, and for that season there could be none. The proprietor had so set his heart on this fine bed, was so hopeful for another year, that I felt shy in offering an opinion. At last, when pressed, I advised him to dig down the half of his bed, to plant a little piece with runners, and as a sort of encouragement, I was to send a lot of young plants, pricked out thickly the previous autumn, just beginning to burst their flower buds. From these little plants he obtained some fair fruit the first season, and they and their runners bore well afterwards. Of the runners planted from the first bed, not one was fruitful the following season. Of the old plants left thinned out and treated as above, some ten per cent. proved moderately fruitful the following season, the bulk, some ninety per cent., producing nothing but leaves.

One other case came prominently under my observation. The kinds were Keens' Seedling, Elton, and British Queen. The plants all looked well, but showed little bloom. Thinned out and treated as above, Keens' was much improved; British Queen was less so, but much better; but the Elton scarcely showed a flower bud.

The matter thus coming prominently before me, I have stated convictions based on what I think to be facts. I know that many hold a contrary opinion, but mere opinion is of little value unless based on something solid and tangible. It should ever be our aim, not so much to excite mere controversy as to get at the truth and what will bear on general utility. Whether contrary to or corroborative of these statements, I shall be glad to know the ideas of others, founded on observation and experience. Meanwhile, as a mere matter of common prudence, I would say, in conclusion, to all makers of fresh plantations of Strawberry plants, Choose your young plants from plants that have produced fruit.—R. F.]

THE ORCHARD HOUSE.

HAVING just seen "T. F.'s" remarks about potted trees (see page 260 of last volume), I should like to make a few observations on the subject. "T. F." has been already somewhat roughly handled by yourself, and one or two of your correspondents, and I have something to add on the same side. "T. F.'s" observations might operate upon those who have dabbled in orchard houses with doubtful success; but it is not very likely that they will have much effect on those who have tried the orchard house and found it answer. There can be little doubt that these structures are specially adapted for amateurs. Professed gardeners have, for the most part, voted them a nuisance from the beginning.

Only a fortnight ago I made a purposed visit to a celebrated nursery famed, not long ago, for orchard houses and orchard-house trees. I had read a glowing account of these, and was anxious to impart or receive hints on the management of the trees, as the case might be. On asking one of the workmen where the orchard house was, he pointed me to a lot of trees, in pots it is true, but ignominiously expelled from their previous more dignified quarters. On the foreman making his appearance, I good-humouredly rated him on the subject, and he was fain to admit that he and his brethren generally had a thorough contempt and dislike for the system. Now, as regards the attention required, it must be owned that for six months in the year it must be careful and unremitting. But it should be borne in mind that that attention pertains to a season in which there is a constant progression from flowers to fruit. There is the gratification of oneself and friends, first of all with the sight of foliage and fruit, to be at length consummated

by the gratification of the taste in eating it; and during the winter months, when there is nothing to be seen, no attention is required.

You put the matter well in stating that this mode of growing fruit brings an all-but-certain crop, and at an early stage of the tree's growth. I had two maiden Plums last November twelvemonth, Pond's Seedling and the Golden Drop; the former has this year fifteen Plums on it, and the latter eleven—quite as many as trees of that age and of these varieties should be allowed to produce. I myself budded a Reine Claude de Bavy two years ago last July. It is now a beautiful pyramid with the fruit reduced by thinning to thirty-four. I will venture to say, I might have had a tree of that variety in the open ground a dozen years, and not have had so many during the whole time. I should have been satisfied in my rough houses with growing Plums alone. I have fifteen varieties of these, and nearly all the trees after thinning have, perhaps, more fruit on them than ought to be allowed, ranging in number from fifteen to thirty. I have ten Peach trees averaging a dozen on each. Apricots, moreover, are doing well, and as in the case of the maiden Plums, two Apricots the same age have two dozen between them.

With regard to the number of fruit potted trees should bear, there is, I think, a little confusion. It would be much better if the matter were more regulated by weight than number. Take, for instance, a Golden Drop or Jefferson Plum and a Green Gage. I should allow the latter to bear at least double the number of the former. The same rule should be applied throughout, so that a tree from five to six years old should be allowed to produce from 4 to 5 lbs. of fruit and no more.

We learn to modify and alter our plans and modes of treatment from time to time. I give less water to my trees than I did two or three years ago, and with good results, but, of course, with careful watching. Up to last year I perceived the leaves at the points to a considerable extent brown and shrivelled. I attributed it to syringing in the morning in bright sunshine. This year I do not syringe uniformly in the morning, but do it liberally about sunset. The leaves thus continue damp all the night, making an uncomfortable home for the red spider.

With regard to "T. F.'s" motto, "Let us down with such torture and cruelty," I have been cruel enough to pinch rather closely all along; but having read M. Du Breuil's book, I am now pinching the Peaches more closely than ever. I cannot tell what the result may be, but appearances are in its favour. My trees are looking more promising this year than usual.—J. M.

A CLEAR HEAD, A PROMPT WILL, AND A READY HAND.

"I DON'T believe it." "Don't believe what?" was the reasonable response, for my friend was not aware that I was reading about Selsey, and that Bede stated it was so called because seals frequented the coast. I read the passage aloud. "Well," said my friend, "Venerable Bede was more likely to know than you." "Not a bit of it; he might be venerable as an ecclesiastic, and not at all venerable as an etymologist. You remind me of the boy who wrote the word 'sut,' and justified it on the ground that the chimney-sweeper so spelt, and 'he ought to know!'" "What's your guess at the derivation?" "Sel, a mansion, and sea, the sea—pure Anglo Saxon." No response from my friend, so I conclude it was convincing. He resumed his writing, I returned to my book.

"It's just 800 years since." "Since what?" said my again-interrupted friend. "Since the bishop's see was removed from Selsey to Chichester." "Who cares about that?" said my friend resuming his writing, and I, adjusting my spectacles, again returned to my book.

"It is incredible that he taught them to catch fish, they must have known that." "Who taught—who was taught?" "Wilfrid, Bishop of Hexham, is said to have taught the Selsey men." My friend laid down his pen and inquired, "Why on earth do you keep bothering about Selsey? I was there some years since, and can testify that Lord Selsey keeps his estate there in admirable order. The crops are good, tenants are prosperous, and the whole peninsula is flat as a pancake. The old Anglo-Saxon city's site is now ever under water, and the fishermen cast their nets over shallows still known as 'The Park' and 'The Street.' Now, that's all, so why keep up such a bother?" "All! Why, that sulphurator you tried and so belauded at South Kensington is made at a manufactory at Selsey." "No! Humbug; a manufactory is as likely to be found

at the Needles or Land's End." But I was not to be batted down in that mode, so I talked at intervals, as much as was politic, until luncheon time, and then and there, over "the cakes and ale," my friend agreed to journey with me the next day to Selsey. It's not the first time we have so journeyed; and now, as on former occasions, we had gleaned relative gleanings, and what follows were our conjoint contributions.

The Wilfrid already mentioned founded at Selsey a monastery of Benedictines; and Bede says that when, for the endowment of that and the bishopric, the South-Saxon king gave Wilfrid the whole peninsula, he gave him also the inhabitants, and Wilfrid by baptising them rescued them from the servitude of the Devil. A subsequent bishop, however, found that posching reduced them again to be Satan's slaves, for Bishop Bede in 1407, by a mandate still preserved, condemned to the greater excommunication certain "children of damnation, who, influenced by the spirit of the Devil," killed game in the bishop's demesne of Selsey. The greater excommunication was no trivial infliction, for it not only excluded the excommunicant from the church sacraments, but rendered him incapable of any legal act, and forbade his intercourse with any of the faithful. Moreover, if he did not within forty days pacify the ecclesiastic who excommunicated him, a writ was issuable for his apprehension and close confinement until he submitted and obtained absolution. I wonder what fine the bishop imposed upon the "children of damnation" before he forgave their venison theft.

No venison is in Selsey now, for, as already told, the inroads of the sea have involved the bishop's park, and the whole peninsula is well enclosed and highly cultivated. The prevailing soil is a strong loam, and now, despite the prolonged drought, the Wheat crops were vigorous and heavy. I say the peninsula is "well enclosed," because the fences are all so thoroughly sustained that they afford unmistakable evidence that Lord Selsey and the farmers—landlord and tenants—are all worthy of the relationship.

Despite the long drought all vegetation looked vigorous. Never did Roses look more healthy—one more instance confirming our opinion that mildew and blotched leaves are chiefly due to ungenial temperature. We should have liked to explore the sands for the Sea Bindweed (*Convolvulus edosandella*), a native of the Selsey shore, and to search for the Sea Pink (*Dianthus profler*), once abundant, but said now to be found there no longer. Want of time, however, forbade our visiting elsewhere than the manufactory, our special object. A pilgrim had been there before us, and thus well sketches an outline of what he saw at Mr. Colin Pullinger's:—

"We entered a large yard, with the figurehead of some old vessel staring us out of countenance. There were some sheds, carthouses, stables, and stores on the one hand, and a line of workshops on the other. 'We cannot afford to use a steam engine yet,' he said, 'so we get our motive power from poor old Bob,' and he kindly patted the horse upon the neck as it passed us on its circular journey. I could hear the baz, the whir, the whiz of the machinery, but mingled with it I heard, too, the notes of a fine old hymn tune. 'My lads don't always sing hymns; they have a song occasionally,' said my conductor, and he added, 'sawing up the wood is rather monotonous work; they have little to think about, for the circular saws are all so guarded that they can't have an accident, nor can they make a false cut. So I allow them to sing while at this kind of work,—it keeps them in good temper.'

"We stepped into the shop and saw a dozen wheels revolving; there were saws, from the size of a crown-piece up to 3 or 4 feet in diameter, hissing their way through the wood; there were holes being drilled; queer-shaped bits of wood fashioned into form; wire and zinc cut up like so much thread or paper; and all with the unerring regularity of a bit of watchwork. It was pointed out to me that each man and boy had a form, or mould, to work by, thus rendering it impossible that even a tin-tack could be driven into the wrong place, or a scrap of wire cut too long by so much as a hair's breadth. The whole of this machinery (with the exception of the circular saws) was not only invented by Mr. Pullinger, but actually made upon the premises, and by the men and boys gathered out of a village where the one half are fishermen, the other agricultural labourers.

"I am not going to describe the processes passed through in making a single trap; it might be tedious, or, to be more candid, I should be sure to fail in doing it. Nor shall I say a word about Pullinger's patent self-adjusting trap; it is too widely known to need that, though few may know where or by whom they are made. The individual traps sell for a mere trifle, yet each one is composed of seventy pieces; each side of the trap passes through twenty-eight hands, and, after the pieces are all made, it passes through the hands of twenty-seven more; in all, about 120 distinct operations are required for the making of one trap.

"The 'hands' whom I saw working in the various shops varied in

age from about seven to seventy. The youngest was poking about in a tray of dust with a common magnet. I asked what the little fellow was doing, and received a characteristic answer—one that should be written up and followed in every workshop in the world; it was:—'We cannot afford to lose anything here. He is picking out every stray tack, every scrap of wire, every morsel of metal of any kind which may have been dropped among the sawdust. It is like play for him.' The little man looked up with a happy face, and proudly pointed to a couple of nails dangling from the end of his magnet.

"We had just left the last shop, when, at a given signal, all left work for the night. 'Some of them will be back by-and-by,' said my guide; and then, upon inquiry, I found that the boys and a few of the adults came to an evening school, of which Mr. Pullinger and his foreman were the teachers. The lads availed themselves fully of the advantage, and in winter time the average attendance was about thirty. Mr. Pullinger has also established a penny bank for the use of his workmen, and there are rather more than forty depositors. One other little fact, showing the fatherly attention paid by the proprietor to his hands, and I have done. In the middle of the morning's work the boys are allowed to run out in the great yard and have a jolly game among themselves for a quarter of an hour or so."

We confirm all that our pre-pilgrim states, and we add that never was space better economised. The machines for sawing, &c., are very numerous, and have to be so arranged in a limited space that not a foot is wasted—and not a foot is wasted. All the saws are circular, varying in diameter from an inch or two to as many feet, and all are turned by the strength of "Bob." Among the save-alls of time we noticed a double-bladed mortice-chisel, invented by Mr. Pullinger, which cuts both sides of the mortice at once. So deeply were we interested by all we saw and by all which we heard, that we asked Mr. Pullinger to tell us a little of his history, and we publish his reply as an incentive to others:—

"I am a native of Selsey. I have received a very plain education. My parents removed to Brighton when I was about twelve years of age. I was there apprenticed to a law stationer. My master failed in business. I was then a writing clerk in a solicitor's office for about five years. Not liking the confinement, I went to sea for about five years, filling nearly all situations on board ship. My parents were getting old, and wished me to give up the sea. I came again to Selsey, where I undertook to do anything which was offered me to do. I was never apprenticed to any mechanical trade, but found no difficulty in doing any sort of work. I always had an inventive talent, but it was years before I could bring it to any use; whatever I made or invented was thought but little of by my neighbours. I made a mouse trap. They then pitied me for the sake of my wife and children, thinking I should bring them to want; the mouse traps sold. I could not make them fast enough by hand, I had not the means to buy machinery, so I made it myself. I always found as soon as I made one thing I could improve upon another; and so I went on, always an up-hill game with me, for all my profits went to inventions and improvements, but by perseverance I overcame all difficulties. My machines I always made of the most simple description, so that I could get the children, labourers, and fishermen to use them, and so that they could not well make a mistake in their work. To many a man from the plough or fisherman in the winter when out of work have I given employment, otherwise they must have gone into the union house at West Hampnett, as well as many children who, when they enter my employment, I consider as my own, teaching them all I know in the day, and in winter evenings having a school, and charging 2/ per week to every one who likes to attend to be taught reading, writing, and arithmetic, although that is at a great loss to me, having no assistance from any one. I employ many teachers, so that the children may receive all the instruction possible, and to many who could neither read nor write I have given a fair education. I take but little credit to myself for what I have done; it comes into my mind with but little thinking; the same as what you said to me last evening came into my mind this morning—a thought entered my mind, I carried it out, tried the invention, and found it answer, before nine o'clock. The only thing I think where I have done some good is in having spent hundreds of pounds in labour, and given many a family a dinner who otherwise would have been without one."

Mr. Pullinger proposes showing this year at the "Workmen's International Exhibition," to be held in the Agricultural Hall, Islington, the following inventions:—

1. Automaton mouse trap.—Each mouse caught resets the trap.
2. Perpetual mouse trap.—Always set.
3. Self-acting mouse trap.—Each mouse caught resets the trap.
4. An improved rat trap.—One of the best to catch rats.
5. An improved beetle trap.—Will catch hundreds at once.
6. An improved eel spear.—To catch more than others.
7. A sulphur distributor.—To destroy mildew, &c., on Vines, flowers, &c.
8. A washing machine.—Saving labour, money, and confusion.
9. A wringing machine.—Simple and effective.
10. Cinder sifter.—To sift without dust.
11. Cask stand.—To stoop with ease and draw off clear.
12. Tapping mallet.—To drive in and take out taps.
13. Model for a steam boat.—To obtain greater speed.

14. Morticing chisel.—To cut both sides at once.
15. Bradawl.—To drive in and jump out again.
16. An improved plane.—To keep the mouth always fine.
17. A machine to straighten wire.—Simple and effective.

The sulphurator and the mouse traps we have tried, and can testify are very effective. The traps continue selling at the rate of nearly two thousand weekly; and we were much amused by the foreman observing that he was with Mr. Pullinger when he first commenced making them, fourteen years since, and he added, "When we had made six dozen we wondered who'd have 'em." The following is a drawing of the sulphurator and



mode of employing it. It is a box fitting on to the nozzle of a common pair of bellows, and so made that every puff of air delivered from the bellows diffuses a cloud of sulphur over the parts of the tree towards which it is directed.—G.

THE FRENCH HORTICULTURAL EXHIBITION.

(Concluded from page 392.)

AFTER having seen as far as was stated in the Journal of June 2nd, I naturally enough looked for the bouquets, vegetables, and objects of art. These I found arranged in the arcades at each end of the Palais.

Bouquets were not numerous, being confined to two exhibitors only, but were very tastefully arranged; they consisted of bouquets for weddings, balls, hall, table and drawing-room decoration, the latter built up in vases of fanciful pottery. One very handsome and rich centre-piece consisted entirely of Orchids, and was lovely. A silver-gilt medal was awarded to M. Bernard, 3, Boulevard Malesherbes, and a silver-gilt medal to M. Labronier, 9, Rue de Seze. Both were well worthy of what they gained.

Exotic fruits were very well represented by one house—viz., that of M. Hediard, 13, Rue Notre Dame de Lorette, Paris, and to whom a silver-gilt medal was awarded for the collection. The principal specimens of interest were fresh pods of Vanilla, fresh Dates and Bananas, Pear Oranges, Sweet Lemons (very large); also Loquats, or Japan Medlars, the fruit of *Eriobotrya japonica*; the round bright yellow fruit, about the size of small walnuts, being as produced naturally upon the racemes. The above were all productions from Algeria. Calabasses (or fruit of *Crescentia Cajete*) came from the Island of Martinique; and collections of dried and preserved fruits, Nats, &c., from Guadeloupe, Cochin-China, Havana, Senegal, Spain, and other countries, made the collection very interesting. All the articles were for sale, and although a pretty good trade was kept up, as each article diminished it was replenished from a reserve.

Vegetables were very few, and quite of secondary merit, a fact rather surprising, for much better could be found in the markets. The awards for what were shown consisted of a silver-gilt medal to M. Petit for six passable Cauliflowers, and a large silver medal to M. Lesbre, Ebreuil (Allier), for a large collection of varieties of old Potatoes. Another collection of Potatoes (new) in sixty-two varieties, was exhibited by a M. Heriellard; these received a silver medal. Another large silver medal was awarded to M. Dagnaux for a collection numerous in variety, but very poor in quality. Yet another large silver medal, and this was awarded to M. Entraygues for a small collection, but tolerable in quality; it consisted of six Tomatoes, a few Ashleaf Kidney Potatoes, Dwarf Kidney Beans, young Turnips, Peas, small green and large yellow Cucumbers, two bundles of Asparagus, a bunch of Radishes, and three Melons. This ends the vegetable part, and now attention will be directed to the objects of art and industry exhibited. But there is something that first attracts attention. What is it? Why, some fruit trees. Two Pears, two Apples, two Cherries, two Currants, and two Vines, the whole in pots, trained up spiral columns of galvanised-iron wire, reaching about 2 yards high. The trees shown, as could well be seen, had been trained on this system from their infancy, and had attained three-fourths of the

height of the columns, had plenty of fruit upon them, and, being subjected to pinching, produced a spiral cordon. They were exhibited by the person interested in the sale of the wire columns. The wire was about the size of an ordinary lead pencil. By the side of these trees were two squares planted out with Strawberries and salading, the ground covered with short manure, and one square covered afterwards with earthen tiles, and the other with glass tiles, these being illustrations of how to use the same, offered by the vendor for the purpose of keeping the soil cool and damp for the benefit of the plants cultivated in the summer months. The contrivance has a very clean appearance, as may be supposed, and might be amusing to amateurs, but I doubt it would not answer in large gardens, and, again, must be the means of excluding air, which is so beneficial to the well-being of the plants.

Horticultural structures were fairly illustrated by three or four makers with greenhouses lean-to and span-roofed, propagating houses, &c., and were, with only one exception, entirely of iron, and had curvilinear roofs, this being at the present day the fashion in France. Melon frames were also plentiful, some with oak frames and iron lights, others all of iron, and, being bolted together at the corners, they can be put up in winter in very small space. Messrs. Lefebvre-Dormois, Rue de Fanbourg du Temple, 92, Paris, received a large silver medal for their lean-to, all of iron, which is a very light, airy, and well-made house, but the top part of it is too flat, which occasions drip. Of this I speak from experience, as I have one such house; the defect could be easily remedied, and then the house would be one of the best forms made. There is a railing at the back for the purpose of attaching the cords, by which the straw mats are drawn up every morning in winter, as it must be understood all houses for horticultural purposes are in France covered with the universal *pallasson*, and this latter is generally made at home. They are a great guarantee against frost, and economise fuel, but cause a great deal of litter, which would not be tolerated everywhere. Another exhibitor, A. F. Maury, 17, Rue du Baisson, St. Louis, had several forms of houses, but received no medal. The houses from this exhibitor illustrated means of giving air by opening seven or eight lights at a time, but would not be an improvement on the winch method used in England, and which has been adopted for many years. The one house built with wood in place of iron was from M. Nattier, 240, Boulevard du Prince Eugène, and was said to illustrate a new system of ventilation, but was merely a slight modification of the well-known lantern.

Of boilers, five or six exhibitors came forward with various models of different systems, but I am afraid they would come to grief against an ordinary tubular, and especially a duplex. There was to have been a competition of boilers, but after having been postponed twice it did not come off at all. Our English boiler-makers ought to get up a friendly competition, and bring to light honestly and openly what each of their new or old inventions really can do, and at the same time make it international. It would be an interesting addition to next year's Exhibition, and prove of infinite benefit to the horticultural public.

Cutlery, of French manufacture, was well illustrated by Hardivillé, 218, Rue St. Jacques, Paris, who received a silver medal for the same. This firm is one of the principal for horticultural cutlery in France. One other exhibitor, Marmure, Faubourg Montmartre, 17, Paris, received honourable mention.

Ornamental ironwork, such as spring-bottom chairs for gardens garden seats, tables, iron fencing, and ornamental wirework, from the celebrated "Usine Tronchon," Avenue d'Eylau, 9, Paris, attracted considerable notice and received a large silver medal. Other exhibitors in this class were M. Borel, 10, Quai du Louvre, Paris, and M. L. Binet, Rue des Arts, 22 et 24, Paris, both of whom have received many medals from time to time.

Pumps, syringes, water-carts, &c., came from numerous exhibitors, and all of them had points, either good or bad, as compared with old systems. A most interesting part of the Exhibition were the many forms of jets for fountains. I may state that the Perfect Watering-can, as it is called in the English advertisements, was exhibited as *tabe arrosoir* by Charles Piersdorff, horticulteur, inventeur breveté, S.G.D.G., 110, Avenue de Saint Ouen, Batignolles, Paris, and 73, South Row, Kensal New Town, and was awarded a silver medal for the same. Are there two inventors? and which is the right?

Plant cases were shown in various forms; that which claimed most attention was a round case made in three parts, which may easily be



understood by the accompanying figures. It is made by Fenoglio, 1, Rue de Kabylie, 19, Arrondissement, Paris, who has already

received eight medals in gold, silver, and bronze from Hamburg, Italy, and France. None was given this time.

Vases, reservoirs, flower cases, fountains, &c., made on a new patent system of cement and iron were shown. The iron part is merely wire-work in squares, to which the cement is put on both sides; it appears to be very solid, as several cisterns were sent that had been in constant use for six years, and from which water had been taken out with watering pots, but these samples appeared as solid as ever.

The fly trap, spoken of in the English horticultural journals, was again brought to notice by the inventor himself—viz., M. L. Rommetin, Quai de Valmy, 93, Paris, and although it was not awarded a medal this time, it had already received several.

Imitation china was well shown by Lebourg, 43, Boulevard du Prince Eugène, Paris, in the shape of vases, &c., and was such an excellent imitation of old china-work that it was well worth the silver medal that was awarded. Vases and other ornamental articles for halls and rooms manufactured in delph were well brought forward by Barbizet fils, 17, Place du Trône, Paris, and who deserved well the silver medal that was awarded. M. M. J. Lenne et E. Lenne, Rue des 2 Ponts, 29 et 31 (Ile St. Louis), Paris, received a medal in bronze for the same.

This ends the description of the principal articles of interest, and although there were many things to interest a visitor, the Exhibition cannot, certainly, in some of its parts be said to be a fair illustration of French horticulture in general.—AINSI.

INSECTS INJURIOUS TO THE PEAR TREE.

No. 3.

SPILONOTA CYNOSBATTELLA—RED BUD-CATERPILLAR. It has also been named by entomologists *TORTRIX OCELLANA*, *PENTHINA OCELLANA*, *PYRALIS LUSCANA*, and *TINEA CYNOSBATTELLA*.



The moth is about three-quarters of an inch from tip to tip of the expanded wings. Fore wings white, tinged with brown; brownish black at the base, and blotched with bluish black. Hind wings brownish grey. The caterpillar is dirty flesh-colour, with darker lines down the back and sides; the head and neck brownish black, with pale spots. It passes into the chrysalis state in the flower bud it has attacked. The caterpillar appears at the time of the Pear bloom opening, and the moth is found early in July. The eggs are laid in the buds, and remain through the winter unhatched. A drop of sap often appears on a bud that is attacked. The bud seems glued so as to be unable to open. The caterpillar feeds on the young fruits as well as on the buds. It is full grown in about a month, and then spins a white cocoon, in which it changes to a chrysalis.

To prevent future ravages, the buds attacked should be destroyed with the ravagers they contain.

WATERING.

1st. Is it necessary to water newly-planted subjects, such as bedding plants, or kitchen garden crops? To this I reply—No, and in support of my opinion I advance the following facts. This spring and summer, so far, have proved remarkably dry, and, as usual, I see, as an every-day-affair, watering plants as soon as planted, and that it is followed up for weeks. Now india-rubber tubing is to be had at such a low rate, there seems to be no end of the work, and yet instead of plants looking better they look the contrary.

In the third week of May I turned out my bedding plants; it was very cold and dry, but as there were no signs of rain, and

being anxious to have less every-day-watering, I planted out. The plants having been in the trenches intended for Celery for a month, they were well hardened-off, and though since they were planted there have been but two parts of days rain, of which to-day (June 24th) gave the heaviest fall, I could not wish to see plants better, either as regards bloom (they are to-day a mass of flowers; Christine, Stella, Tom Thumb, Madame Vaucher, and Lord Palmerston Pelargoniums, and *Lobelia speciosa*, being lovely), or for foliage, and that, too, although they have had no water excepting the rain and dew. A friend called here on May 28th, and remarked how well the plants were doing, and said there must be root action. I lifted a plant that had been put in on May 23rd, and there were new white roots three-quarters of an inch long.

Now, I think there is nothing very remarkable about this. In March I manure and deeply dig the beds, which then remain bare till May. Between March and May we have much cold wet weather, but then we have much sunshine, which warms the ground by the time it is ready for planting. I thoroughly water in the morning the plants which I intend planting in the afternoon; I then plant them, and to me it seems like planting them in a gentle hobbed, as though the soil may be cold on the surface, it is not so underneath. The plant then being in a moist state, and the ground warm, the roots commence growing at once, and, of course, the tops will not be far behind.

The points in favour of a plant not being watered are—First, by thoroughly watering the plant some few hours before planting, it fills or feeds the plant, and, therefore, when it is planted out the ground, as I have tried to explain, being warm, it grows at once. Secondly, I lay the plants as near the ground as possible; by doing so, while the wind does not break them, the sap is equalised, causing the plant to become bushy. Thirdly, When it rains the plants grow very fast.

I will now take a case of watering. A plant is planted out; most likely it is very dry, as I have heard men say, Well, we are planting out so-and-so to-day, it will not require watering. Well, it is planted and then watered; in fact, I may call it watering the ground, as the plants receive very little of the water, especially if it is dry before planting, and the consequence is the plant is at a standstill. It cannot grow, the water given taking the warmth out of the ground, and once watering does not serve, and when it rains, having plenty of water before, they do not grow very fast. Let anyone try the two methods, and he will see the difference.

I may add, that in 1868, when plants in general suffered so severely, I had no occasion to water, and yet I had a most beautiful show, though I must say that deep cultivation has much to do with the well-being of plants.

The points against the watering are these:—

1st. By watering you starve the plants and prevent the roots pushing, as they will not grow in cold ground.

2nd. Extra labour, which though one may have, still it is loss of time; and then once water always water, and the ground must be often stirred or it becomes hard.

3rd. Watered plants will not stand the wind and weather, the water causing the tops to be tender.

With regard to kitchen-garden crops, I never water them, Celery excepted, and healthier growth I could not wish to see. In planting both summer and winter crops, I plant in drills. I cut Cauliflower which had received no protection since March 1st, on June 4th; I gathered on June 18th, Ringleader Peas, sown on March 9th, and Myatt's Prolific Potatoes, on June 22nd. This I consider early for my neighbourhood.—STEPHEN CASTLE, *The Gardens, Bent Hill, Prestwich.*

CROSS FERTILISATION AND THE LAW OF SEX IN EUPHORBIA.

MR. CHARLES DARWIN'S interesting observations on cross fertilisation have opened a new world for original discovery. The list of plants which seem to avoid self-fertilisation is already very large. I think *Euphorbia* may be added to the number. Certainly this is the case with *Euphorbia fulgens*, Karw. (*E. jacquiniflora*, Hook.) which I have watched very closely in my greenhouse this winter. Several days before the stamens burst through the involucre, which closely invests them, the pistil, with its ovarium on the long pedicel, has protruded itself beyond, exposed its stigmatic surfaces, and received the pollen from the neighbouring flowers. The way in which the pollen scatters itself is curious. In most flowers a slight jar or a breath of wind will waft the pollen to the stigmas, but I have

not been able to notice any to leave these flowers in this way; for as soon as the anther cells burst the whole stamen falls from its filament-like pedicel, and either drops at once on the pistils of other flowers, or scatters its pollen grains by the force of the fall.

This *Euphorbia* also furnishes another contribution to the theory of sex which I have advanced. The plan on which the male and female organs are formed is evidently a common one; and the only reason why some flower heads have a pistil in the centre, and others are wholly staminate, is, that there is greater *axial vigour when the female flower is formed*. Whenever the common peduncle (below the scarlet involucre) is weak, a pistil never appears in that head of flowers. A few which seem strong neither have them, but the great majority of the strong peduncles are those which bear the female blossoms. Another interesting fact is, that the number of male flowers is less in those heads which also bear a female, than in those which are wholly staminate. This seems to add to the point I made in my paper on *Ambrosia*, that after the flowers have been partially formed in embryo, and before the sex has been finally determined, the female flower, being primordially the stronger, has the power of absorbing the males, or their partially formed elements, into its system. It is certainly remarkable that in both these instances the number of male flowers should decrease in proportion to the existence or vigour of the central female one.

The male and female flowers of *Euphorbia fulgens* are formed much alike. The female occupies the centre, and seems really but a prolongation of the main stem, on the top of which is an articulation from which the ovarium springs. The capsule readily falls from this articulation when mature. From the base of the female central peduncle spring weaker peduncles, colourless, appearing indeed almost like filaments, articulated at about the same height as the female, only above the point bearing a short filament and anther—the caduceous part before referred to. No one can fail to see the correspondence of plan in these different parts, and I think that nothing but the favourable position in the direct line of axial vigour made the central flower a female one.

Cases occasionally occur in which a tolerably strong head of wholly male flowers will develop the central axis into a pedicel almost as long and vigorous as those which bear female flowers. But the flow of vital force—if I am correct in using this term—not being quite sufficient, the final goal of natural perfection in the female form was not reached. These cases do not occur often, but are well worth looking for, as they show so clearly the dividing line between the forces which govern the male or female sex.—THOMAS MEEHAN.—(*Proceedings of Academy of Natural Sciences of Philadelphia.*)

NOTES AND GLEANINGS.

THE SOIRÉE given by the DUKE OF BUCKLEIGH, PRESIDENT OF THE ROYAL HORTICULTURAL SOCIETY, will take place at South Kensington on Wednesday next, July 13th, and not on the 30th, as stated in our last number.

— THE following arrangements have been made for the OXFORD MEETINGS of the ROYAL HORTICULTURAL SOCIETY:—

“Contemporaneously with the Society’s Provincial Show, which is to take place in the grounds of the Observatory at Oxford, it is intended to hold a general meeting of the Society. At this meeting an opportunity will be afforded for the election of new Fellows; and the most remarkable novelties exhibited will be made the subject of comment. This general meeting will be held on Wednesday, July 20th, the chair to be taken at one o’clock.

“Additional meetings will be held on July 20th and 21st for the reading and discussion of papers on subjects of horticultural interest, after the manner of a congress. The gardeners of the United Kingdom, as well as other persons interested in horticultural pursuits, are invited to attend, and to take part in these discussions. Ten minutes will be allowed to each speaker. At these meetings the chair will be taken punctually at 2 P.M. Those who have the intention of speaking upon any of the subjects to be brought forward, are requested to communicate with the Society’s Floral Director, Mr. Thomas Moore, of the Chelsea Botanic Garden, who has been good enough to undertake the organisation of these meetings.

“On Friday, July 22nd, the special prizes will be distributed by the Lord Henry Gordon Lennox, M.P.

“*South Kensington, London, W., June 29th.*”

PROGRAMME OF THE CONGRESS MEETINGS.

Wednesday, July 20th.—W. Wilson Saunders, Esq., F.R.S., in the chair.

1. Dr. Voelker, F.R.S., member of the Society’s Scientific Committee, will give a short lecture on “The Principles of Manning.”

2. Mr. William Ingram, gardener to his Grace the Duke of Rutland, K.G., at Belvoir Castle, will give a short lecture on “The Distribution of Soils, and their Influence on Vegetation.”

Thursday, July 21st.—Major Trevor Clarke in the chair. The following papers will be read and discussed:—

1. Professor Lawsee, M.A., F.L.S., “A Short Account of some of the mere Eminent Oxfordshire Botanists and Gardeners.”
2. Rev. S. Reynolds Hole, M.A., F.R.H.S. “*Roses.*”
3. Mr. William Paul, F.R.H.S. “On Colour in the Tree Scenery of our Gardens, Parks, and Landscapes.”
4. Dr. Hogg, F.L.S., Pomological Director R.H.S. “On Judging Fruits.”
5. Mr. Thomas Moore, F.L.S., Floral Director R.H.S. “On Judging Plants and Flowers.”
6. Mr. Benjamin S. Williams, F.R.H.S. “On Pitcher Plants.” Illustrated by living specimens.

— We have to direct attention to a notice in our advertising columns of an important sale which is to take place at Mr. Stevens’s Rooms, King Street, Covent Garden to-morrow (July 8th); it is that of a valuable collection of stove and greenhouse plants from the Royal Horticultural Society’s Chiswick Garden, whence they must be removed in consequence of the alterations about to be made.

WORK FOR THE WEEK.

KITCHEN GARDEN.

ENDEAVOUR to plant a good breadth of *Celery* forthwith. What is called the Scotch plan of planting—viz., in beds from 4 to 6 feet in width, is that generally considered preferable. These beds, which usually succeed crops of Peas, are trenched two spits deep. The bottom spit has plenty of raw manure or half-decayed leaves, and the top one old manure. The principle points in growing very tender and crisp *Celery*, irrespective of size, is to sow it rather late, and grow it very quickly by means of plenty of manure and moisture. Let a good planting of *Leeks* be made directly, using as much manure as for *Celery*. *Shallots* inclined to ripen should be raised slightly with a Potato fork, in order to admit air to counteract mouldiness. Let a good breadth of autumn *Turnips* be put in without delay, choosing for the kitchen garden the Dutch or Stone.

FRUIT GARDEN.

Birds at this season are troublesome, and it requires netting in abundance to preserve fruit from their ravages. As the fruit is gathered from the earlier Cherries remove the netting, which may serve for protecting later crops. Look over Peaches and Nectarines, and in tying-in the young wood see that the fruit is not too thick. Nailing-in the current year’s wood, and stopping such shoots as are not required for fruiting, are the principal things now to be attended to in this department. It may, however, be advisable to go over such trees as are over-luxuriant, and stop about half the shoots, beginning, of course, with the strongest; for a general stopping at this time would probably be of little further service than to induce the production of a mass of useless spray, whereas stopping the stronger shoots of trees which incline to grossness will divert the sap into the weaker shoots, which will be strengthened, while the buds on the shoots that have been stopped will become full and plump without starting into growth. Should it be found that the roots after stopping incline to start into growth, it will be advisable, as soon as the fruit is gathered, to open a trench at a moderate distance from the stem of the tree, cutting the strongest roots. This may be of the greatest service in checking growth, and will probably do more towards securing ripe wood than anything else that could be adopted. Let the Strawberry plantation intended to stand for next season be trimmed as soon as convenient, cutting off the runners, so as to afford the leaves plenty of room.

FLOWER GARDEN.

During the present continuance of bright weather, frequently examine shrubs transplanted this spring, especially on gravelly soils, to see that they are not suffering from want of water. Give a liberal soaking where necessary. Bedding plants must also be duly attended to with water. As open ground and shrubberies are much more frequented by company at this season than at any other, pay more attention to keeping the greatest neatness and order in every part where there are hands to admit of it. Flowering shrubs as they go out of bloom should have the dead leaves, &c., removed, and be slightly cut back. For the same reasons remove the seed pods from *Rhododendrons* and *Tree Paonies*. Such attention will be followed by an increased growth of the plants, and there will be a greater chance of their blooming every season. The most

forward Carnations and Picotees may now be layered. The layers should be made in light soil, consisting principally of leaf mould. Those shoots which apparently will not become sufficiently strong may be taken off and treated in the same way as Pink pipings. Take every opportunity of fertilising blooms for seed; do not cross a Picotee with a Carnation, and prefer flowers which have a broad, stout, well-formed, and smooth petal. The risk is considerable, even under these circumstances, but the gratification arising from the production of one first-rate flower repays all the trouble. Remove all misshapen blooms of Dablias, and place neat stakes round the main stem, to which the lateral shoots may be attached, otherwise they are apt to be twisted off by high winds. Occasionally examine the pipings of Pinks which are under hand-glasses; remove any that have contracted mouldiness, and carefully extract all weeds from amongst them. Tulips may now be taken up; store them in cabinets with the drawers properly numbered, or put them in thin paper, allowing them to dry gradually in an airy, shady place. Hedges should be well cut-in with shears, unless when formed of large-leaved plants, as Laurel and Turkey Oak, when the knife only should be employed, as the leaves look badly when clipped with shears.

GREENHOUSE AND CONSERVATORY.

Large climbers, with other specimen plants of considerable size, are liable to become pot-bound, and as it is not always expedient to give them a thorough shift, it is a very good plan to sink the pot in another which is somewhat larger. The pot selected should be thoroughly drained, and fibrous heath soil and loam in lumps, with charcoal and pounded crocks, should be laid over the drainage before placing the pot. The rim of the pot inserted may be elevated about one-third of its depth above the level of the exterior pot. This will give room for the prepared compost. After placing it perfectly level the space between the two pots may be filled-up with the same coarse materials. This space affords a good chance of introducing stakes or trellising without injury to the roots. The plants should be fed with liquid manure during the growing season. Camellias may be shifted at this period. It is considered an excellent plan to perform this operation the moment that the flower bud is decidedly formed. As compost, use two-thirds of fibrous loam of an unctuous character, and one-third of fibrous heath soil. The more fibrous and lumpy it is the better; and a good sprinkling of charcoal in small masses, with sharp silver sand, should be added. Let the pots be completely drained by placing some large crocks in a very hollow position at the bottom, topping these up with a pounded mixture of broken pots and charcoal, from which all the very small particles have been riddled. Cover this with very fibrous turf in small lumps before placing the ball, and keep pressing the material—not ramming it—closely with the fingers during the process of filling-up. Have the compost in a mellow state, rather inclining to dryness. One most material point is, to see that the ball is thoroughly moistened before shifting; if any doubt of this exist let the ball be steeped in water for a quarter of an hour previous to potting. Some of the *Staticas*, as *sinuata*, *puberula*, &c., exhausted with blooming, may be shaken out of their pots and repotted. These plants delight in an open compost with thorough drainage, and some of them are partial to a close and moist atmosphere. Stop gross shoots of greenhouse *Azaleas*, and see to cuttings of the best *Pelargoniums*. Continue to pinch off all blossoms from pot *Roses* intended for flowering in November and December, and stop all luxuriant shoots. Young stock of these for winter work should now have their final shift.

STOVE.

Some of the *Bletias*, as also the old *Phajus grandifolius*, are well adapted for producing winter flowers. Such should have their growth completed with all possible rapidity; they enjoy abundance of liquid manure. Occasionally stop the shoots of some of the young plants of *Euphorbia aequiniflora*, they will produce a succession of later blossom.—W. KEANE.

DOINGS OF THE LAST WEEK.

We had on the 1st of the month a few showers which refreshed the foliage of plants and cooled the surface of the parched soil, though they did not reach the roots nor replenish reservoirs. We took advantage of the shade to plant out a quantity of *Brussels Sprouts*, *Scotch Kale*, and *Cauliflowers*, drawing drills, and planting in the drills after puddling the roots, and watering

with sewage immediately afterwards. The plants now look established. We should have liked to have planted out much more, but we have no ground at liberty, all of it being crammed until we can get some *Pea* and *Strawberry ground* empty. It is comparatively easy gardening when a quarter or two can be found empty for winter *Greens* and spring *Broccoli*. Contrary to our custom we have planted *Brussels Sprouts* and other *Greens* in the place which had been filled, up to within a few days, chiefly with *Scotch Cabbaging Kale*—that and *Veitch's Dwarf* being about the best, the *Cabbaging Kale* yielding fine gatherings of soft and tender shoots to the end of June, and making a change with *Cauliflowers* and *Cabbages*. Nothing beats them, except the sprouts from *Coleworts* that have stood all the winter, and the most compact *Cauliflowers*. These shoots from the *Coleworts* were far before the most crisp young *Cabbages*, though they, too, were very good. The *Coleworts* filled the north side of a sloping bank, and they looked so well and lasted so well, that instead of removing them we planted *Potatoes* between them; but we fear we left the *Coleworts* too long for the good of the *Potatoes*, as the ground was too much exhausted as well as shaded at first. However, we expect that with surface-stirring there will still be a moderate crop of *Potatoes* to come in after the early ones on the south side are done, which as yet have yielded unusually well, are quite ripe, and will be lifted for the sake of room. We mention this merely as a sample of the way in which many of us must crop. Even *Cauliflowers* planted 2 feet apart in rows must generally have a crop of *Radishes*, *Spinach*, or *Lettuce* between them.

As to the piece planted with winter *Greens* after having carried such a heavy crop of the same kind, though contrary to our general practice of rotation of cropping, the plan may be adopted at times with impunity. In a neat little garden which has been noticed in these pages, we much err if one border has not carried a crop of *Brussels Sprouts* for more than twenty years, and done it well all that time. We presume it would yearly have a dressing of manure. We put a fair allowance on our piece, and trenched it over to from 18 to 24 inches deep, mixing the manure with the soil, instead of turning it in at the bottom. The trenching was fully confirmatory of what has been recently stated of plants, when established, drawing up moisture from beneath. The roots of that fine plantation had gone far down for moisture. To the depth of nearly 2 feet the soil was the driest we ever saw, so dry that even the lower spit would scarcely lie on the spade, but was inclined to fall off like so much kiln-dried sand. We made holes with a pickaxe, and found vigorous roots of the old *Kale* 3 and 4 feet from the surface, clasping the dampish clay. So dry was the soil near the surface, that but for adding the manure, we should have been inclined to have made holes with a crowbar without digging, and watered the holes before and after planting. In such loose, fresh-turned-up, dry soil, it would be next to impossible to firm plants properly, and, therefore, the surface was well trodden, and then heavily rolled, before the drills were drawn for planting the young plants.

People would save themselves much uneasiness if they would but recollect, that plants fully established will get moisture from beneath, or send their roots down in search of it. We all know that a dry summer generally yields us the finest crops of *Wheat*. This is not because the roots can do with so much less moisture; but because the drier and warmer atmosphere snits the plants, and the roots obtain moisture from beneath. We have carefully traced the roots of *Wheat* to more than 3 feet in depth. We believe that others more careful have found them deeper than that, though *Wheat*, perhaps more than most plants, rejoices in a firm, consolidated soil.

It is with fresh-planted-out plants that the chief difficulty is to be found where there is scarcity of water. It would be of little use transplanting *Lettuces*, for instance, unless you could water and shade; but taken on the whole, our *Lettuces* sown thinly in well-stirred soil, and thinned out early, have been as crisp as usual, and have stood pretty well the usual time before showing the flower stem.

Some remarks have been made about our speaking of *paraol Cabbage* leaves in such a season as this; but as an evidence of what can be done in a holding soil, and giving the plants the full chance of catering for themselves as regards moisture, we may mention that on measuring a number of the larger leaves near the base of the plant we found them average 18 inches in length and 20 inches in breadth. These plants had one watering (a moderate one) of house sewage. We know the ground will be a mass of roots to a considerable depth. This *Cabbage* is a very good early kind. We obtained the seeds from Mr.

Cannon, of Hitchen, who grows largely for sale, and is quite as distinguished with his fine Broccoli. We believe it is chiefly owing to his practical treatment, giving ground entirely to the Broccoli crop, and having his plants a yard apart every way. This is a very different thing from many gardeners, who must continue to get Broccoli when the young plants are smothered and drawn up lanky when growing between Peas and other crops. If a tradesman finds it so remunerative to give such a free space to his Broccoli, is not this an argument, where fine vegetables are desired, to give the gardener the ground to grow them in? But to return to the parasol-leaved Cabbages. Fine as they are, they might be too large for some of our readers who have but little ground, and to them we can safely recommend Veitch's Matchless. It very soon forms a heart, though of small size. We have measured the leaves, which stand rather upright, and find they would average about 8 inches by 7, with a nice compact Cabbage in the centre. Such a compact kind will thrive well in rows 16 inches apart, and the plants 12 inches from each other in the row. This kind also yields second and third crops very freely. Of the larger sort alluded to—a regular fill-basket for a large establishment, the young Cabbages are coming so freely from the stumps, that we shall be tempted to give them a sewage-watering at the first opportunity. Unless the winter proves very severe, our spring Cabbages generally yield profuse gatherings until April in the following year.

The seed leaves of our first-sown Cabbages are just coming through the ground. We shall sow again about the time this is printed. The ground turned up very dry. It was left a little rough, and well soaked with sewage. When it became drish on the surface it was levelled down, the seeds (red-leaved) were scattered over it, beaten in with the back of a clean spade, and then covered with from one-eighth to a quarter of an inch of riddled dry soil, left dry and open. The seedlings looked very well when they came through it. A little charcoal dust is an excellent material to mix with the dry surface covering. Thus securing moisture beneath is far better than surface waterings, which cake the surface and interfere with the seedlings supplying themselves with moisture from beneath.

Early Peas.—Sowed some rows of early Peas, and if the weather promises to be fine will make one sowing more. With the early kinds, so far as earliness is concerned we have no fault to find. Sutton's Ringleader is good, and so is Carter's Early and Chater's (of Cambridge) Early. Of all such, with us Chater's was the most prolific, but though all earlier for a week or so, none yielded like a good sample of Sangster's No. 1. We hope our seedsmen will keep that sort true, as in crowded gardens it is almost impossible to do so. Times were when seedmen would send half a dozen kinds by name out of the same bag, and we fear that Sangster's will have a chance of being lost, an earlier sort being sent instead that would not yield a fourth of the gathering—a matter often of more moment than a few days' earliness in picking. Dickson's Favorite is a fine second early Pea, and our young Peas taste well, though the haulm is getting mildewed.

Mildew.—This has led us to note a little matter, though it may afterwards prove to be of small moment. All our earliest and second early Peas that showed signs of mildew were sown in drills in the usual way. The drills were rather narrow at the bottom, being drawn out with the hoe in the ordinary method, and the Peas sown quite thickly enough in the bottom of the drill. The second early and succession Peas—that is, those coming into pod, those coming into bloom, and those younger, as yet green and flourishing, and showing no signs of mildew, were sown in the old-fashioned way we used to practise many years ago, and renewed again of late, and more especially this year, when signs of a dry season began to appear. The ground was well dug and pulverised, and where possible moderately enriched. A narrow trench the width of a spade was then thrown right and left, say 4 inches deep, a little rotten manure was thrown over its bottom, and just lightly forked in; the bottom of the shallow trench was then trodden and well watered. In an hour or less, if the sun was bright, the points of a fork were just drawn along the watered bottom to make the surface a little open and rough, and then the seeds were scattered thickly over the sunk space, say 7 inches wide, the seeds ranging from 1½ to 2 inches from each other. The seeds were patted down with the back of a clean spade, and covered with nearly an inch of the dry soil from the sides. Peas so treated, even in this dry summer, have as yet shown no mildew, and no great signs of distress.

FRUIT DEPARTMENT.

We did much work in shortening the shoots of fruit trees, as referred to last week, and gathered a large quantity of Strawberries and Raspberries for preserving. If we have rain or can water freely, there will be plenty more of both. Our house-keeper tells us she never before had Strawberries that stood so well to bulk and remained so firm. No doubt this was owing to the sun and dryness leaving little moisture in the berries. We know of many instances in which the makers of Rhubarb jam complained of the hardness of the Rhubarb stalks, but now they are forced to own that they never had such rich and firm jam and jelly before—there was so little watery juice in the stalks. We must think of taking off Strawberry runners for forcing next season. Cherries on walls this season, unwatered and unsyringed, are very good; Cherries on standards in the open have been smaller than usual; Cherries in pots in the orchard house have been fine, because to these water must be given or the plants would die.

ORNAMENTAL DEPARTMENT.

Here our chief work has been switching the lawn with the Daisy knife to remove Plantain stalks, a few Daisies, some flowers of Dutch Clover, and yellow blooms of the Lotus corniculatus. The lawn is a little brown, but a good shower would make it green. Clipped the sides of walks, and swept and rolled to give a fresh smooth surface. A few dull days would give us more growth in the beds, and then there would soon be masses of bloom. Watered Roses with sewage water. They much like it if not too strong. The wood is now in good order for budding, and we know no more delightful work for the amateur and the cottager to engage in. In most gardens of any size where the labour power is always at full stretch, it will be most economical in every way to obtain supplies from our great Rose growers. The regular budder, from practice, puts his buds in with a rapidity and a certainty that mere casual budders might look on with astonishment.

Bedding plants have now obtained good hold, and mostly must cater for themselves. The showers encouraged us to turn out lots of Asters, Stocks, Wallflowers, and annuals. Firmness in planting is a great point in such a season as this—in fact, in any season. When the dibber is used it is the one oblique stroke that fastens the roots securely. When the trowel is used for a plant with a ball, the chief error is to attempt to fasten the roots by pressing downwards, which is apt to disarrange and destroy the roots. The right way is to make the hole large enough, and to press the finely-pulverised earth to the ball laterally. When this is done, water well, to settle all the roots in their places, before quite finishing at the surface.

Much has been done in pricking off and potting Chinese Primulas, Broomallias, Cinerarias, and potting and repotting Balsams. The Cinerarias, fresh potted in small pots, were placed under glass in a cold frame, with its high side to the south, as they will want less water than if they stood out of doors.

Much has been done in repotting, and here we met with several instances where the plants did not seem to be right, and yet the modes detailed the other week for knowing whether a plant was damp enough at the roots had been tried without avail. The surface and bottom of the ball were quite right as respects moisture, and so was the ball for about 2 inches deep all round; therefore, though we had suspicions that part of the roots were dry, the suspicions were lulled by the dull sound that came from the pot when struck. The truth is that the outside of the ball was moist enough, and contained fine, healthy roots; the inside of the ball was dry. To make it wet without repotting, it would have been necessary to have made small holes, or to have set the pot in water. In our case, after getting rid of a lot of the old soil, the ball was set in water until the centre was thoroughly moistened. Very likely these plants had been potted last, when the ball was comparatively dry. This would account for the surface and the outside of the ball being moist, whilst the centre was so dry. There is no more common error—none that ruins pot plants more than this—potting them afresh whilst the soil of the old ball is dry. No common watering will ever thoroughly wet that dry soil again; the moisture given will always escape by the looser soil at the sides. Make sure, then, first of all, that the ball of a plant is sufficiently moist before placing it in a new and larger pot. And once more, in repotting use soil neither wet nor dry—wet enough to retain the marks of your fingers when you squeeze a handful tightly, dry enough that that handful will fall to pieces when you lay it down on the

potting-board. If wetter, it may be too compressed to allow water to percolate freely; if drier, there is a great difficulty in common watering to get the whole regularly moistened.—R. F.

TO CORRESPONDENTS.

•• We request that no one will write privately to any of the correspondents of the "Journal of Horticulture, Cottage Gardener, and Country Gentleman." By so doing they are subjected to unjustifiable trouble and expense. All communications should therefore be addressed solely to *The Editors of the Journal of Horticulture, &c.*, 171, Fleet Street, London, E.C.

We also request that correspondents will not mix up on the same sheet questions relating to Gardening and those on Poultry and Bee subjects, if they expect to get them answered promptly and conveniently, but write them on separate communications. Also never to send more than two or three questions at once.

N.B.—Many questions must remain unanswered until next week.

BOOKS (J. W., Liverpool).—“Fruit Gardening for the Many” contains all you require about Strawberry culture. You can have it from our office, post free, if you enclose five postage stamps with your address.

TENANT REMOVING SHRUBS (Yorkshire).—You have no legal right to remove shrubs or plants from the garden, although they were inserted and have been cultivated by yourself for seven years. Cannot you divide each plant, put one part in a pot, and leave the other part? The potted portions you might take away.

MEASURING GLAZIERS' WORK (A. W.).—Unless specified to the contrary, glazing by the foot is measured on the square—that is, the greatest length and breadth; at least that used to be the case. The true measurement of angles and triangles, as ends and corners, would only be half a square; but a glazier could not do it on such measurement, he would have such a waste of glass in the sharp angles. No doubt this makes the difference in the number of glazed feet. Circular-topped windows are measured the same way—by the square.

MISTAKES AT LOCAL SHOWS (E. G.).—We cannot spare space for recording such mistakes. You should write to the Committee.

GALVANISING PLANTS (A. D.).—The experiment with the two Pelargoniums was too imperfect to merit reporting. The results from half a dozen galvanised, and half a dozen ungalvanised, with proper precautions, would be more worthy of confidence.

SEEDS FOR ARKANSAS (Pangbourne).—They will need no special packing. In small paper packets will be the best form. Any seeds that will succeed in England will succeed there.

PELARGONIUM—LOBELIA (S. Kidley).—The box was smashed. There was no Lobelia, and only a few petals of the Pelargonium. Their colour and markings are not uncommon.

ZONAL PELARGONIUMS (Quara St.).—We cannot recommend dealers. Any of the principal ferists who advertise in this Journal could supply the varieties you name.

SEEDLING PELARGONIUMS (W. O. B., Dublin).—The petals were nearly all shed, and the box smashed. There are many Pelargoniums with similarly coloured and marked petals.

SEEDLING TRICOLOR PELARGONIUM (E. Shepton).—It is handsome, but the leaf sent was precisely like *Sophia Dumasques*.

PANSY DISEASED (E. M.).—The cuttings of the Pansy reached us safely last week. The yellow spots are the fungus *Oidium Viola*. A hybrid between a Fern and Pansy is an impossibility, as cryptogamic and phenogamous plants have no affinity. We do not remember receiving Pansies previously.

ROSE LA SÉDUISANTE (Centurion).—We do not know a Tea-scented Rose of that name, but there is an old Hybrid Perpetual as well as the Alba Rose. Most probably it is the Hybrid Perpetual that you have. You must wait for the flowers.

CHARCOAL FOR ROSES (J. B.).—It is a good manure for Roses both in pots and in the open ground. One-sixth of the compost is sufficient for Roses in pots; and for giving colour to the flowers it may be applied to the surface of the soil in the pots, and just scratched in with a piece of pointed wood. If the surface be covered about an eighth of an inch deep it is sufficient. For those in the open ground a dressing a quarter of an inch thick is not too much.

BRUSH FOR KILLING THE ROSE APHIS (W. T. D'r.).—We have used the brush you speak of to remove green fly from Roses, and find it useful but rather tedious. If Roses are well mulched and manured during the winter they will very seldom suffer much from aphids. We do not quite know whether your Rose plant which had its leaf perforated suffered from the weevil or the Rose Cutter beetle. If from the former, handpicking would be quite effectual; if, as we suspect, it was the latter, you would have done no good by cutting down the plant, as the Rose Cutter beetle merely cuts the leaf to take it away to line the sides of its nest, and when the nest is complete will commit no more ravages. Singularly enough, these beetles generally confine their attacks to one plant; they usually select a plant with stiff short foliage, and the nest will be found in a small hole in the ground near the tree. The Rose Cutter beetle always begins its perforation at the outside of the leaf, and cuts a semicircular piece out of the side.

BOILERS (L. C. J., Dudley).—We never venture to commend any.

MANURES (H., Tunbridge Wells).—You do not quote accurately. We recommend dry earth and coal ashes to be used when saturated with sewage, which has to be stored. Coal ashes so employed would not be injurious to any soil; and if the soil be tenacious they would be beneficial employed even in large quantities unsaturated with sewage. They would improve the soil's staple.

PARSLEY TURNING BROWN AND YELLOW (“*Idem*”).—But for being brownish yellow, the specimens of Parsley sent seem to be a fairly good curled, close kind. This turning yellow might be owing to the great dryness—most probably owing to some reason of which we are ignorant. As it is best to err on the safe side, and as defects are easily perpetuated, even if the plants would ripen their seed, we should not care to sow it, unless as an experiment, as such withered-looking Parsley would never be used in the kitchen.

HEATING A REMOVABLE HOUSE (T. M. L.).—Such a span-roofed house as you propose we would build entirely on the ground, with perhaps one course of bricks for the window-sill to rest on. The roof, &c., we would form of rafter sash-bars, say to receive glass 18 inches wide. These bars we would groove to receive the glass edge to edge without putty, and merely fasten the squares in their places with small list, soft cord, or rope yarn, fixed in the groove beneath the glass. Provided the groove is made deep enough to allow room for the glass to expand, there will be no breakage from expansion, and if the glass is well cut there will be no leakage. The bottom square will require a pin to keep it from sliding out. With the roof screwed, and these squares in place, you can take all your glass out, and the house to pieces, and pack in little space. As to heating for ease in moving, nothing could be better than a small gas stove; but as, on the whole, you might not have gas at your next place, it would on the whole be best and cheapest to have a small iron stove fed at the side, the smoke-pipe coming from the opposite side, and rising with a bend through the roof, with a flat top to the stove to receive a vessel of water. Supposing the stove stood in the centre of the house, the small smoke-pipe from it might go through the roof near the apex. A 3 or 4-inch pipe would answer if frequently cleaned. People cannot, or will not, see how easy it is to take such a pipe through a glass roof; all you have to do is to substitute a square of plate iron for a square of glass, with a suitable hole in the iron to let the pipe through. The pipe should have a cap over it outside, to prevent the rain and snow falling into it. If you prefer a gas stove—and there are good ones to be had with argand burners that consume almost the whole of the gas—even in such a case have a small pipe, if only from a quarter to half an inch, to take off the products of combustion into the open air.

RAISING WATER (Edmonton).—The best reply we can give is to publish the following, for which we are indebted to our weekly contemporary, *The English Mechanic and Mirror of Science*. The accompanying drawing will explain a cheap method of making a force pump for watering. One has been in use some time. A, common lead pipe; B, valve; C, solid plunger from pump; D, outlet pipe; E, small cask, or any suitable air-

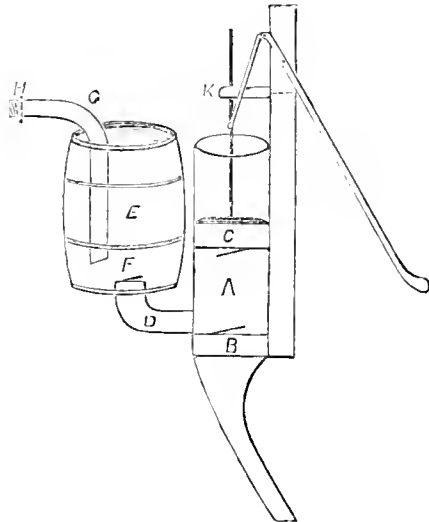

tight vessel holding about 6 gallons; F, valve; G, outlet pipe, reaching to within about 2 inches of the bottom; K, guide for plunge-rod. It can now be used as a common pump by having a union; an india-rubber or any other pipe may be screwed on, and there would be sufficient force to carry a continual stream 60 feet high. The cask, or air-tight vessel may be placed at any distance from the pump; a round hole in the bottom, with a piece of stout leather weighted, is all that is required for the valve."

FAILURE IN HEATING (Inquirer).—We are glad you refer again to flue-heating, as instanced at page 191, No 467, for March 10th. It seems we were quite right in our surmises. No flue will draw regularly with the furnace-bars level with the middle of the flue, as respects its depth, and we wonder you were not smothered from the want of a regular asphit below the fire-bars. Your proposal to let the present flue remain, but block it up; let the fire-bars remain, but break a hole through the present flue at the end of the furnace; and place a flue of hard-burned earthenware pipes of 9 inches in diameter on the top of the present flue, will, no doubt, answer much better. But even then your furnace-bars will scarcely be low enough, and instead of a foot you would require to build a brick flue from 1 to 2 yards in length on the top of the old flue before using the pipes, as such pipes are apt to crack when too near the surface. We have a great sympathy with people wishing to carry out their own plans. We do not, therefore, repeat our advice, "Try the flue again," for as it is, it will not answer, but as the flue is there, why not "try it again" with a little alteration? Would it not be easier to dig down and sink your furnace-bars from 18 to 24 inches, instead of making this new flue on the top of the old one? Then, instead of the bars being in the middle of the flue as now, your bars would be below the bottom of the flue. However, try your own plan if you like it best.

ICE HOUSE (J. D. Whithead).—All ice houses, as a rule, keep ice best in proportion to the quantity of ice put in. A few loads, however protected, will seldom last after midsummer. We know the plan of Cobbett's you have adopted answers well, but, of course, the smallest opening would be ruinous, and it would be of no use where rats or rabbits could burrow in the straw, as every hole made would let in the heated air. Ice stacks, if looked after, and from fifty to a hundred loads put together, answer well, as described at the page in the "Gardeners' Dictionary" you refer to; but even in their case, holes from vermin must be looked after, and the covering must be put on so as not to heat. We have ourselves no doubt that a house on Cobbett's plan, either above or below ground, with double walls and double roof, with a space, say of 6 inches between, would answer well, as if made of brick or stone there would be no air holes easily formed, as there is almost sure to be in most districts where gnawing and burrowing animals abound, and the walls are wood and straw. See article in No. 304, vol. xii., page 64.

SPAN-ROOFED FRUIT HOUSE (J. Reader).—We have given plans and descriptions of cheap houses, and there are advertisements in our pages which may be referred to and depended on. You can do better for yourself, knowing the circumstances in your own neighbourhood, than we can do for you. For instance, a fixed roof could be put up for less than the half of one with sashes, and the heating for such a house will be very different, if you want Grapes ripe in May, than if you were satisfied to have them in July and onwards. Peach trees for the centre of the house you could purchase at 1s. 6d. per plant, and yet it might be true economy to have plants at from 7s. 6d. and onwards. In such a house, 20 feet wide, and glass all round, eight 4-inch pipes the length of the house would not be too many to have Grapes ripe in the beginning of May. The Grapes that would come in best then would be Black Hamburgh, Sweetwater, and Royal Muscadine; and if you wish to give a chance to the Peaches in the centre, six or seven Vines on a side will be enough. An upright tubular boiler is rather the easiest to manage, but otherwise there is no great difference between that and a terminal saddle-back. The price of shelving and fitting up depends much on the material used, and altogether your case is one more for local inquiry and agreement than could be satisfactorily entered largely upon in our pages.

PLANTING WHOLE POTATOES (Calcearia).—We approve of this practice. Let us know the quantities produced by you and your neighbour, and we will publish the same with notes.

LAWN COVERED WITH DAISIES (W. F.).—To destroy them you acted judiciously in top-dressing the whole lawn with a mixture of good loam and well-rotted dung, and in April sowing the whole with a suitable mixture of grass seeds. If you let the grass grow long, in a season or two it will probably choke the Daisies. To prevent the Daisies ripening their seeds, take the flowers off with the Daisy rake. If you do this, and have the roots of the survivors scooped out with a knife in the autumn and spring, you will subdue them entirely.

ANTHRUM SCHERZERIANUM, TEMPERATURE FOR (S. E.).—This beautiful plant requires at this season a temperature of from 65° to 70° at night, and 75° by day without sun, and from 80° to 85° or 90° with sun and air. It does very well in the stove during the summer.

INCREASING ANTHRUM SCHERZERIANUM (X. O.).—Your best plan of inducing your plant to form offsets will be to give it a more moist and warmer atmosphere, as well as every stimulus to growth, and thus, no doubt, you will have a larger plant, but not so many flowers. The taking out of the crown of the plant—just its centre—would be likely to afford an increase of the crowns.

MELON TREATMENT (J. F. S.).—The lights should not be covered after May. It is only so long as the nights are cold that coverings are needed. When the nights are becoming cold in autumn it is essential to cover the lights as in spring, but it will not be necessary to do so before the close of September. The bed should be lined as may be found necessary for maintaining the proper temperature. During the very bright weather we had a short time ago it was not necessary. If the temperature at 6 A.M. is 65° no linings are required; with us it is often under 60° at night, and we have Melons now in beds made up but a short time before yours, and the beds have not been lined more than twice. Melons will endure a great amount of heat. 85° to 90°, however, with sun and abundance of air, is quite sufficient, but they will bear from 100° to 110° without injury if they have air. It must, however, be from sun heat. We would now line the bed with sweet dung, give a good watering, but without wetting the surface, by pouring water through a funnel or drain-pipe, and by giving plenty of air we think the fruit will set. The flower is all right.

CULTURE OF BLACK CURRANTS (J. Poor Lady).—We do not think it would answer to prune the bushes now, cutting them back in the hope of obtaining shoots for next year's bearing; but it would be of great benefit to give liberal supplies of liquid manure in dry weather throughout the summer, thinning out the shoots now where too thick. Where very long and straggling they may be shortened, but take care to leave a sufficient number of shoots for bearing next year. The best manure is cow dung, as it is cool, but any kind will answer. Apply the manure in autumn, after the leaves fall, removing the soil down to the roots to the extent of about 2 feet all round the stem; then give 2 or 3 inches thick of manure, and cover with about an inch of soil. The manure need not be more than half decayed. Road scrapings are not of much value; and guano, though it will do good, ought to be applied in moist weather only, and in small quantities at a time.

MILDEWED VINES (C. E.).—We do not see what you can do now, except to dust the mildewed parts with flowers of sulphur, to paint your walls with sulphur and lime, to use a little sulphur in your heating medium, and to give as much air as is compatible with the health of the Vines and other plants. A close moist atmosphere is the fertile source of mildew; the reverse condition keeps it away or starves it. Mildew is often the result of many plants being kept close and damp beneath the Vines. If you do not allow the Vines to be too thick on the roof, we do not think the mildew will much affect them, but the more moisture and closeness there is in the house, the more difficult will it be to eradicate the mildew. We see little use in cutting the Vines down if you mean to take fresh growth from them. Such mildew is, generally speaking, more owing to atmospheric than to root or earth causes.

GRAPES SMALL AND ILL COLOURED (J. F. H.).—We think very likely the smallness of the Grapes, and their colouring irregularly, are owing to the dryness and poorness of the border. If the previous watering is not

enough, water again with manure water. Keep, as you say, a little heat in the house whilst you give air freely; meanwhile, the mere irregular colouring is often no great drawback. When a few berries colour well, the others generally follow suit, if they are firm and perfect.

GRAPES DISEASED (M. D. C.).—They are shranked and spotted also. Remove the soil from over the roots, replace it with some richer soil, and water copiously twice a week with tepid weak liquid manure. The roots are unable to supply sufficient sap.

MILDEW ON GRAPES (Vitis).—Dust them thoroughly with flowers of sulphur. After the sulphur has been on three or four days, syringe the Grapes. If after two more days the mildew is still apparent, apply the sulphur again, and continue repeating the treatment until the mildew is entirely removed.

SULPHURING GRAPES (Centurion).—It is not necessary to syringe the Grapes and Vines previous to dusting them with sulphur for destroying mildew. The sulphur will readily adhere to the Grapes and the leaves of the Vines. There is no necessity for washing off the sulphur; it may remain until the mildew is destroyed, and then be syringed off with clean rain water. If this be done when the Grapes show colour it will be soon enough, though we usually wash off the sulphur within a week, but if the mildew reappears it is necessary to repeat the sulphur-dressing and the subsequent washing. Air should be admitted as usual; if anything, more air should be given after than before the application. Your gardener is quite right in giving all the air possible in bright hot weather, but to do so in cold dull weather will lower the temperature needlessly, and unless fires are put on the warmth needful for ripening the Grapes cannot be maintained. We advise you not to nail up the front and west sashes. It is very important that a greenhouse, and, indeed, every plant structure, should be well ventilated.

LILIUM ATRATUM AND LANCIFOLIUM TREATMENT (C. M. Major).—We consider the best time to repot these plants is as soon as the stems turn yellow in autumn. Cut down the stems, remove all the old soil that comes away freely, and that above the crowns, along with any roots on the stem and offsets, but all the roots below the bulb should be preserved. Drain the pot well, and put in a mixture of light fibrous loam two parts, one part sandy peat or leaf soil, and one part old cow dung or well-rotted manure, with a free admixture of sharp sand. The plants should be so potted that a space of 2 or 3 inches above the bulbs will be left for top-dressing. They should have a gentle watering and be placed in a cool house, and kept there with but little water until they begin to grow in spring; then water so as to keep the soil moist, increasing the supply with the growth. Abundance of air should be given, and if the plants be kept cool they will flower all the better, the top-dressing being given when they begin showing roots from the stem above the crown. The same compost as that used for potting will answer very well. The soil should be kept moderately moist in winter, but avoid souring it at any time by too frequent heavy waterings.

VALLOTA PERPUEA CULTURE (Idem).—We presume your plants are growing freely, but you cannot get them to flower. Having now made a good growth, place them in a light airy position, and give no more water than enough to keep the leaves from flagging, with an inclination to dryness, and continue this treatment up to the end of August, when your plants should be starting for flower; if they do not, continue them in the same pots, and give just enough water to keep the foliage fresh. In winter they merely require a light position in a house with a temperature of from 40° to 45°. In summer they need plenty of light, and a good supply of water when making their growth and until it is perfected, then dryness. An ordinary greenhouse will grow them well.

INSECTS (C. E. E.).—Your "nigger" is the larva of one of the Carabidae, and as it feeds on other insects and worms, you cannot do better than preserve them if you find others. (J. T. S.).—The Beech leaves have been attacked by the minute black jumping weevil, *Orchestes Fagi*, the larva of which lives within the leaf, eating the parenchyma, and making large blister-like blotches. When full-grown it spins a white silken cocoon of the size of a pea at the edge of the leaf. The little beetles are now making their appearance out of their cocoons. They also feed on the leaf, gnawing round holes. (E. Hazard).—Your moth is the Humming-bird Hawk Moth, which has been somewhat common during the last two or three years. It is quite harmless to your flowers. (L. H.).—Your *Cecropia* moth survived the loss of its head on the same principle that the common daddy-long-legs seems so indifferent to the loss of its limbs. The nervous mass is, in fact, in insects not concentrated as in the higher animals into the brain, but is distributed in knots along the whole length of the body. The respiratory apertures along the whole length of the sides of the creature are not connected with the sense of feeling.—I. O. W.

NAMES OF PLANTS (South Devon).—The commonest of Ferns, *Polypodium vulgare*.

POULTRY, BEE, AND PIGEON CHRONICLE.

SPALDING POULTRY SHOW.

In reply to Mr. Patrick's communication last week respecting the loss of sickle feathers in his birds after exhibition at this Show, permit me to assure him that the most careful investigation fails to discover any possibility of such a thing having occurred while they were in the custody of our Committee. Evidently the occurrence must have taken place in transit, and our Committee will gladly add another £5 to Mr. Patrick's to secure the conviction of the perpetrator of this spiteful act, and will take care that the rewards are duly announced in Mr. Patrick's neighbourhood as well as our own. It seems rather strange if, as Mr. Patrick states, the same thing occurred to his birds last year, that he sent them again, and neither at that time nor when sending them this year made any complaint nor remark on the subject. The perpetrator would seem

to have been actuated by personal feeling against Mr. Patrick, as neither at our late nor any of the previous shows have we heard the slightest complaint of any other birds having been injured or tampered with.—EDMD. CAMMACK, *Poultry Secretary.*

THE POULTRY FANCY IN CANADA.

THE other day I noticed the publication of the first number of a new poultry journal in the United States, as an evidence of the growth of "the fancy" across the water. I have just received by mail the announcement of another journal to be published in Canada. The first number is to be published on the 1st of July, under the title of the *Canadian Poultry Chronicle*, but it will also be open to matter relating to Pigeons, birds, dogs, Rabbits, and similar subjects. The paper is to appear monthly, and the subscription price is one dollar-and-a-half per annum. I imagine that the readiest way of remitting subscriptions from England would be a money order for 6s. The address is Box 25, Post-office, Toronto. The embryo journal and its editors (whose names are not yet disclosed), are strongly recommended by several well-known Canadian fanciers, including Colonel Hassard, whose able address, or paper, read to some of the colonial breeders was reported in the Journal some time back.

All eminent breeders should take in both of these transatlantic papers. Apart from all other considerations, I can assure them, from personal knowledge, that the poultry fancy is making rapid strides across the water, and that the American market will offer a valuable and most lucrative channel for the disposal of good surplus stock. I say good, for the exportation of mere "scraws" assuredly will not pay, but will entail both disgrace and loss.—L. WRIGHT.

TESTIMONIAL TO MR. DIXON.

ABOUT two years ago a well-merited tribute was paid to one of our leading poultry judges, and I think the present a well-timed opportunity for a similar mark of esteem to be paid to another gentleman, who is well known as one of the founders of the fancy; who for a great number of years was the leading exhibitor; and who, at present, is one of our most accomplished judges. I think I need scarcely say I refer to James Dixon, Esq., of Bradford.

Mr. Dixon being a gentleman of means, I think the testimonial ought to take some other shape than money, but the exact form can be left for subsequent consideration, and under these circumstances the amount of subscription will be limited to 10s. 6d., but smaller sums will, of course, be received. The amount is placed thus low to enable all classes of fanciers and exhibitors to show their appreciation of his services.—E. HUTTON, *Pulsey, Leeds.*

BEEES ATTACKING CHICKENS.

Your correspondent, Mr. J. Elcome, has inquired whether any of your readers has heard of bees attacking fowls. In 1845 I put a hen under a coop with a large brood of chickens near a bee hive, and they had not been near each other above a day when the bees made a most violent attack upon the chickens, and killed several of them; in fact, I do not recollect whether any of them escaped. It was a warning to me never again to place chickens near a bee hive.—SENEC.

BURNLEY POULTRY SHOW.

THIS was held on June 30th, and was well attended by exhibitors, there being upwards of 280 entries of Poultry, Pigeons, and Rabbits. The following are the awards:—

GAME.—Black or Brown-Reds.—1 and *hc.*, C. W. Brierley, Middleton. 2, J. Brough, Carlisle. *Cock*.—1 and 2, C. W. Brierley, *hc.*, J. Brough. *Any other Variety*.—*Cock*.—1, C. W. Brierley. *Hen*.—1, C. W. Brierley. 2, R. Whittam, Burnley. SPANISH.—1, H. Wilkinson, Earby. 2, W. Bearpark, Ainderby Steeple. DORKING.—1, J. Stott, Healey, Rochdale. 2, W. Bearpark, COCHIN-CHINA.—1 and 2, J. G. Broxup, Burnley. HAMBURG.—*Golden-spangled*.—1, H. Bantam, jun., Earby, Skipton. 2, W. Driver, Keighley. *hc.*, N. Marlor, Denton, Manchester. *Golden-pencilled*.—1 and 2, H. Pickles, jun., *hc.*, W. Clayton, Keighley. *c.*, F. S. Driver. *Silver-spangled*.—1, J. Fielding, Newchurch, Kossendale. 2 and *hc.*, H. Pickles, jun. *Silver-pencilled*.—1, F. & C. Haworth, Newfield, Haslingden. 2 and *hc.*, H. Pickles, jun. *Black*.—1, N. Marlor, Denton. 2, H. W. Illingworth, Idle, Leeds. *hc.*, D. Lord, Stacksteads, Manchester. BRAHMA FOOT.—1, J. H. Pickles, Birkdale, Southport. 2, E. Leech, Rochdale. BANTAM.—*Game*.—*Cock*.—1, Harwood & Buckley, Accrington. 2, G. Harwood, Holdenwood, near Haslingden. *hc.*, J. Oldroyd, Wakefield; F. Jackson, Scars, Brierfield. *Game*.—*Black or Brown-Reds*.—1, T. Barker. 2, J. Oldroyd. *Game*.—*Any other Variety*.—1, Bellingham & Gill, Woodfield. 2, R. Whittam, Burnley. *hc.*, G. Frouess, Church. *Any other variety except Game*.—1, J. Walker, Halifax. 2, H. Pickles, jun. *hc.*, M. Leno, Markyate Street, Dunstable (Golden and Silver-laced). *ANY OTHER VARIETY*.—1, H. Pickles, jun. (Silver Polands). 2, T. Dean, Keighley (Polands). *hc.*, H. B. Smith, Bronzton, Preston (White-crested Black Poland). DUCKS.—*Aylesbury*.—1, E. Leech. 2, M. Wilkinson, Worsthorpe. *Rouen*.—1, E. Leech. 2, H. B. Smith. *hc.*, C. W. Brierley. *Any*

other Variety.—1, C. W. Brierley. 2, S. & R. Ashton, Roe Cross, Mottram, Cheshire (Pintails). *hc.*, B. Conderdie, Brookfield, Littleborough, GEESE. 1, E. Leech. 2, W. Halstead, Cockden, Burnley. TURKEYS.—1, E. Leech. 2, C. W. Brierley.

PIGEONS.

CARRIERS.—1 and 2, E. Horner, Harwood, Leeds. *hc.*, J. Hawley, Bingley; H. Yardley, Birmingham. POUTERS.—1, E. Horner. 2 and *hc.*, J. Hawley. TUMBLES.—1, J. Hawley. 2, J. Fielding. 3, J. Fielding, jun. 4, J. Fielding, jun.; Rochdale. 2, J. Hawley. *Mottled*.—1, J. Fielding, jun. 2, H. Yardley. *hc.*, J. Hawley. BARNS.—1, E. Horner. 2, J. Hamilton, Haslingden. *hc.*, H. Yardley. OWLS.—1 and 2, J. Fielding. *hc.*, W. Buckley, Blackburn. TRUMPETERS.—1, E. Horner. 2, J. Hawley. JACOBS.—1 and *hc.*, E. Horner. 2, J. Hawley. FANTAILS.—1, J. Hawley. 2, J. Kemp, Haslingden. *hc.*, E. Horner. TURBITS.—1, J. Hawley. 2, E. Horner. *hc.*, H. Yardley. ANTWERPS.—*Short-faced*.—1, J. Oldroyd, Wakefield. 2, E. Horner. *hc.*, H. Yardley; J. Parker, Burnley. DRAGONS.—1, E. Horner. 2, J. Hawley. *hc.*, D. Neill, Darwen; H. Yardley. *ANY OTHER VARIETY*.—1, E. Horner. 2, J. Hawley. *hc.*, W. Kitcher, Feniscowles, near Blackburn (Magpies).

RABBITS.

LOP-EARED.—1, W. Slater, Burnley. 2, N. H. Ellis, Accrington. *hc.*, H. Creeke, Burnley. *ANY OTHER VARIETY*.—1, W. J. Butterworth, Stoneyfield, Rochdale. 2, L. Pickles, Birkhouse, Cliviger, Burnley.

JUDGES.—Mr. James Fletcher, and Mr. John Martin.

BEVERLEY POULTRY SHOW.

THIS meeting, held on June 29th, was exceedingly well supported, and the weather being fine and cool, the attendance of visitors was most satisfactory. Perhaps Beverley has never before possessed so good *Game* classes, every colour being represented by fowls of the highest quality. Although the bulk of the *Spanish* had evidently been much taxed by repeated and almost continuous exhibition, there were many of first-rate character. *Dorkings* were good; but one of the best pens was defeated by the fact of the hen being seriously ruptured—a fatal objection to her equally as a show and a stock bird. *Cochins* were unusually good throughout, and the *Hamburgs* and *Polands* were all that could be desired. *Game Bantams* were sadly out of condition, and in *Sebrights* two pens were shown by different exhibitors, in which the cocks were without tail feathers; it is a pity to show birds in so deep moult, as it tends to heavily bear on the constitution, already materially weakened by the natural changing of plumage. The *Ducks* were unusually fine.

The best show of *Pigeons* ever seen at Beverley was that of this year. The varieties most noticeable were the Carriers, Dragons, Almonds, Fantails, and Jacobsins. Of Trumpeters, Turbints, Antwerps, and Nans there was also a very fine collection. The "Variety class" and the Selling class of Pigeons were of high merit. The arrangements were precisely those carried out at the Beverley Show for more than a dozen years past, and, with the exception that the pens for the fowls were placed rather too low, we believe they could not be improved. The Royal Assembly Rooms, in which the Show was held, afford the greatest comfort for both visitors and poultry, and the light is excellent. Once more we strongly suggest to exhibitors, Never trust to the last train, as several most praiseworthy pens were not delivered at Beverley till long after the Show was open to the public.

GAME.—*Black-breasted or other Reds*.—1, W. Boyes, Beverley. 2, S. Matthew, Stowmarket. *hc.*, D. Gellatly, Meikle; G. Holmes, Driffield; C. H. M. Julian, Hull. *Any other Variety*.—1, Cup, and *hc.*, W. Boyes. 2, H. M. Julian. *hc.*, W. Mathew, G. Pombock, Kiryopondale. 3, G. Sutton, Boothby. 4, W. Boyes. *hc.*, H. M. Julian; G. Brentnall, Barton-on-Trent. SPANISH.—1, H. Beldon, Bingley. 2, J. Walker, Wolverhampton. *hc.*, E. Jones, Clifton; Messrs. T. C. & E. Newbitt, Epworth (2). *c.*, J. Smith, Long Leith, Keighley. DORKING.—1, Mrs. F. S. Arkwright, Sutton Sealsdale. 2, J. Stott, Healey. *hc.*, H. Lingwood, Barking, Suffolk (2). COCHINS.—*Cinnamon or Buff*.—1 and Cup, J. Cattell, Birmingham. 2, H. Lingwood, *hc.*, R. White, Sharnbrook, Sheffeld; W. A. Taylor, Manchester (2). *c.*, W. A. Burrell, Southow. *Any other Variety*.—1, W. A. Taylor. 2, R. White, G. White, Whitley, Netherthorpe; J. Sichel, Hamersay.—*Golden-spangled*.—1, W. A. Hyde, Ilurst, Ashton-under-Lyne. 2, D. Maynard, Driffield. *hc.*, H. Beldon (2); J. Newton, Asdn-n, Leeds; G. Garbutt, Sinnington. *Silver-spangled*.—1, Cup, and 2, H. Beldon. *Golden-pencilled*.—1, H. Beldon. 2, G. Holmes, Driffield. *hc.*, H. Beldon. *Silver-pencilled*.—1, and 2, H. Beldon. *Polish*.—1, Cup, and 2, H. Beldon. *hc.*, J. Watts; J. M. Proctor, Hull. FRENGEN FOWLS.—1, Mrs. J. Cross, Brzgr. 2, J. Elgar, Newark. *hc.*, H. Wrenham, Wawne (2). *c.*, J. K. Fowler, Aylesbury. BRAHMA.—1, G. F. Whitehouse, King's Heath. 2, J. Elgar. *hc.*, H. Beldon; H. Lingwood; W. Gamon; Dr. J. Holmes, Whitecotes, Chesterfield. *c.*, J. H. Dawes, Moseley Hall. *ANY OTHER VARIETY*.—1, R. Loft, Wootton Bassett (Sultans). 2, W. Collyer, Dobb, Bingley (Black Hamburgs). *hc.*, H. W. Illingworth, Idle, Leeds; J. Smith. SELLING CLASS.—1, H. Wrenham (Creve-Coeur). 2, T. C. & E. Newbitt (Spanish fowls). *hc.*, W. A. Taylor, *c.*, H. Beldon; G. Loft; W. Boyes. GAME BANTAM.—1, H. Beldon. 2, G. F. Entwistle, Westfield, Cleckton. 3, J. Oldroyd, Wakefield. *hc.*, A. Stabler, Driffield. 4, *Cock*.—1, and *hc.*, W. Adams, Epworth. 2, J. F. Robinson, Sunderland. *hc.*, W. F. Entwistle; G. Shrimpton, Leighton Buzzard. BANTAM.—1, T. C. & E. Newbitt (Black Bantams). 2, H. Beldon (Light Japanese). *hc.*, T. C. Harrison, Hull; J. Watts (Sebrights); S. & R. Ashton, Roe Cross, Mottram. *c.*, J. Watts (Booted Bantams); S. S. Mossop, Long Sutton. DUCKS.—*Aylesbury*.—1, Mrs. Seaman. 2, W. Stonehouse. *hc.*, E. Leech; J. K. Fowler (2); Mrs. Seaman. *Rouen*.—1, J. White. 2, J. K. Fowler. *hc.*, E. Leech. *ANY OTHER VARIETY*.—1, E. W. Richardson (Carolina). 2, T. C. Harrison (Ramsay). *hc.*, R. W. Richardson (Widgeon); T. C. Harrison (Mandarin). *c.*, S. & R. Ashton (Garganeys); J. K. Fowler (Carolina).

PIGEONS.

CARRIER.—*Cock*.—1, H. Yardley, Birmingham. 2, J. F. White, Birmingham. 3, and *hc.*, J. C. Ord, Pimlico. *c.*, W. R. & H. O. Blinksop, Newcastle. *Hen*.—1 and 3, J. C. Ord. 2, H. Yardley. *hc.*, H. Headley, Leicester. *c.*, T. H. Freeman, Liverpool. POUTER.—*Cock*.—1, H. Yardley. 2, H. Beldon. 3, S. Robson, Brotherton. *Hen*.—1, H. Beldon. 2, Withheld. 3, F. Key. ALMOND.—*Cock*.—1, H. Adams. 2, F. Key. 3, J. Ford. *c.*, J. Ford; H. Adams; H. Headley. *Hen*.—1, H. Adams. 2 and 3, J. Ford. TUMBLES.—*Cock*.—1 and 2, H. Adams. 3, H. Beldon. *Hen*.—1, H. Beldon. 2 and 3, H. Adams. BYRONS.—1, H. Yardley. 2, H. Bingley. 3, N. combe, Garganeys. *ANY OTHER VARIETY*.—1, H. Adams. 2, F. Key. 3, H. Beldon. *hc.*, H. Yardley; J. M. Proctor. ENGLISH OWLS.—1, A. Jackson, Heaton, Bolton-le-Moor. 2, J. Watts. 3, Messrs. Blinksop, *hc.*, H. Yardley. FANTAILS.—1, Mrs. H. Adams. 2 and 3, H. Yardley. *hc.*, H. Beldon. *c.*, T. H. Freeman. JACOBS.—1, R. Bellamy, Leven. 2, R. Sanders, Leven. 3, H. Yardley. TRUMPETERS.—1, S. Robson. 2, H. Beldon. 3, T. Statters, Hull. TURBITS.—1, Messrs. Blinksop. 2, R. W. Richardson. 3, F. W. Medcalf, Cambridge. *hc.*, A. A. Vander Meerach (Yellow); R. W. Richardson. DRAGONS.

—1, H. Adams. 2, R. W. Richardson. 3, H. Yardley. c, H. Beldon; T. H. Frean. **ANTWERPS**—1 and 2, H. Yardley. 3, T. Statters. *hc*, H. Yardley; J. Watts. **NUNS**—1, H. Yardley. 2, E. C. Davis, Kingston-upon-Hull. 3, H. Adams. *hc*, W. Charter, Driffield. **ANY OTHER VARIETY**—1, H. Beldon (Black Fairies). 2, H. Headley (Isabels). 3, G. H. Withington, Kersal Hill, Manchester (Ruster). *hc*, J. Watts; H. Adams; R. W. Richardson; T. H. Frean; J. J. Watts; Messrs. Hudson & Bunyip, Edworth; H. Yardley. **SELLING CLASS**—1, H. Adams (White Dragons). 2, J. Watts (Mane Pigeons). 3, H. Yardley (Hyacinths). *hc*, H. Beldon. c, G. H. Withington; H. Yardley; R. W. Richardson; Mrs. H. Adams.

CANARIES.

BELGIAN—1, F. Tritschler, Beverley. 2 and c, W. Needler, Hull. *hc*, J. Down, Beverley. **HALF-BLOOD**—1, G. H. Withington. *hc*, J. Down, c, J. Powell, Beverley. Mrs. Grant, Beverley. **MARKED**—1, R. Jefferys, Market Weighton. 2, W. Bielby, Willow Grove. *hc*, J. S. Petch. c.—Widdall, Beverley. **ANY OTHER VARIETY**—1, A. Lewis, Hull. 2, Miss Young, Driffield. *hc*, Miss E. Canpey, Beverley. c, Mrs. J. Powell, Beverley. **NEST OF YOUNG**—*Clear*—1, T. Neall, Beverley. 2, J. Downs. *hc*, Mrs. Pierson, Beverley. c, J. Canpey, Beverley. *Marked*—1, J. Sykes, Market Weighton. 2, Miss E. Brady. *hc*, Mrs. Pierson. c, T. Canpey. **WOLFEISEN**—1, J. Canpey. 2, Mrs. Potage, Beverley. *hc*, Miss Holmes. **MISS L. HOLMES**. **GOLDEN MILE**—*Variagated*—1 and 2, W. Needler. *hc*, J. S. Petch. *Dark*—1, J. S. Petch. 2, Miss Widdall. *hc* and c, T. Neall. **EXTRA STOCK**—*hc*, Mrs. W. Dale, Beverley (Paroquet); W. Dale, Beverley (Waxbills); G. B. Holmes; Wilson and Sons, Hull; Mrs. Pierson (Cage of Birds). The whole class worthy of prizes.

The Judge was Edward Hewitt, Esq., of Eden Cottage, Sparkbrook, Birmingham.

BARNSTABLE POULTRY SHOW.

This was held on the 29th and 30th of June, in connection with a horticultural show. The prize list is as follows:—

COCHIN-CHINA—1, F. Brewer, Lostwithiel. 2, W. L. Trewin, Barnstaple. **BRABMAS**—1, J. Beard, St. Blazey. 2, Mrs. Smith, Canaple, Tavistock. **MALAYS, OR INDIAN GAME**—1, A. Small, Bishop's Tawton. 2 and c, H. Darch, Stratton. **GAME**—*Black-breasted Red*—1, J. Boyle, Barnstaple. 2, J. Beard. *Any other Variety*—1, Rev. G. S. Cruwys, Cruwys Morchard, Taverton. 2, J. Westcott, Barnstaple. **DORINGS**—*Coloured*—1, W. J. Medway, Newton Abbot. 2, R. Harris. **ANY OTHER VARIETY**—1, R. Harris. 2, J. Woodley, Stratton. **ANY OTHER VARIETY EXCEPT BANTAMS**—1, W. Littlejohns, Piton. 2, W. L. Trewin, Kilkhampton. 3, T. H. Shorton, Falmouth. 4, J. H. Nicholls. **BANTAMS**—*Game*—1, W. Mudge, Blagton. 2, E. M. Webber, Exeter. 3, J. Croote. *Any other Variety*—1 and 2, Rev. G. S. Cruwys. 3, S. Woodman, Barnstaple. c, R. L. Hole, Hanaford. **TURKEYS**—1, A. C. Thinne. 2, Mrs. Smith. **GUINEA FOWLS**—1, T. J. Dennis. 2, O. A. Young, Driffield. **GEESSE**—*Any Variety*—1, E. B. Molecomb, Buckland Brewer. 2, E. B. Molecomb, Bideford. **DUCKS**—*Rouen or Aylesbury*—1, S. R. Harris, Lostwithiel. *any other Variety*—1, S. R. Harris. **SELLING CLASS**—*Goose*—1, S. R. Harris. 2, J. E. Hawken. *Hen or Pullet*—1, F. Brewer. 2, G. H. Gregory, Taunton. *hc*, J. Medway, Newton Abbot.

PIGEONS.

CARRIERS—1, Master C. Bulpin. 2, H. Yardley, Birmingham. *hc*, Mrs. F. J. Bulpin, Bridgewater. **POUTERS**—1, Miss F. J. Bulpin. 2, Mrs. M. G. Bulpin. c, Master C. W. S. Bulpin. **TEMBLES**—1, Master C. W. S. Bulpin, Bridgewater. 2, H. Yardley. *hc*, W. Westcott, jun., Barnstaple. **BARRS**—1, H. Yardley. 2 and *hc*, J. L. Smith. **JACOBS**—1, W. Westcott, jun. 2, H. Yardley. *hc*, Master C. W. S. Bulpin. **OWLS**—1, J. L. Smith, Newport, Barnstaple. 2, W. Westcott, jun. **FANTAILS**—1, Master C. Bulpin. 2, J. S. Sleath, Barnstaple. *hc*, Miss F. J. Bulpin; H. Yardley. **TRUMPETERS**—1, Mrs. M. J. Bulpin. 2, W. H. Green. *hc*, H. Yardley; G. H. Gregory, Taunton. **TURNING**—1, J. G. Price, Taunton. c, G. Bulpin. **NUNS**—1, G. Bulpin. 2, M. M. J. Bulpin. c, H. Yardley. **ANY OTHER VARIETY**—1, H. Yardley. 2, G. H. Gregory.

BRITISH AND FOREIGN GAME AND OTHER BIRDS—1, No. 231. 2, A. Nicholls, Newport, Barnstaple.

JUNGES.—Dr. Scott and the Rev. G. F. Hodson.

BELFAST POULTRY SHOW.

The North-east of Ireland Agricultural Association held its annual meeting at Belfast on June 23rd and 24th. The number of entries in nearly every department was greater than at any previous Show.

Most of the poultry classes were well represented, and nearly all contained more or less good birds. The challenge cup, value ten guineas, was won by Mr. Mulligan, of Springfield, near Belfast. This gentleman showed some very good birds, and he took all the first prizes for Ducks and ducklings with birds which were very perfect both in plumage and bill. The *Dorking* class contained twelve pens, mostly Silver-Greys, and some of them very good and large. The prize pens in the *Spanish* class were good, but the rest of the class inferior. The *Cochins* were the best class in the Show, and besides the three prize pens, four pens were highly commended, and one commended. The *Brahmas* were not a large class, but the prize pens were above the average. The *Hamburgh* classes were not up to the mark, but we suppose they are a breed not much kept in Ireland. Some of the *Game* were very good; the best hen in the class was in the second-prize pen, but she was matched with one of very middling quality. We would suggest in future shows, that in the Game classes only one hen should be required. The *Geese* and *Ducks* were good.

DORING (Any colour)—1 and 3, G. Martin, Castlereagh (Silver Grey). 2, W. Charley, Dunmurry. *hc*, W. G. Mulligan. *Chickens*—1, G. Martin (Silver Grey). 2, F. H. Green, Belfast. **SPANISH**—1 and 3, W. G. Mulligan. 2, F. H. Green. *Chickens*—1 and 2, W. G. Mulligan. 3, G. Martin. *hc*, G. Martin. **COCHIN-CHINA**—1, F. H. Green (Lemon-coloured). 2 and 3, W. G. Mulligan (Buff). *hc*, F. H. Green (Iris-bred); S. T. Scott, Belfast; R. Long, Belfast (White); G. A. Perrin, Chantilly, Loughlinstown, Co. Dubbin. c, R. Long. **BRAMA POUTRA**—1, F. H. Green (Dark). 2 and 3, W. G. Mulligan (Dark). **SCOTT'S GREYS**—1, R. Long. 2 and 3, W. G. Mulligan. *hc*, G. Martin. **HAMBURGH**—*Silver-spangled*—1, F. H. Green. 2 and 3, W. J. Davison. *any other Variety*—1 and 2, C. E. M'Clintock, Glendaragh, Craugha. 3, W. J. Davison. *Golden-spangled*—1, W. J. Davison. 2 and 3, F. H. Green. *Golden-spangled*,

1, F. H. Green. 2, G. Martin. 3, W. J. Davison. c, E. M'Clintock. **GAME** (Any colour)—1, C. E. M'Clintock (Black-breasted Red). 2 and 3, G. A. Perrin (Duck-wings and Brown Red). *hc*, C. E. M'Clintock (Black-breasted Red); R. Long; G. A. Perrin (Black Red). **BANTAMS** (Any breed)—1, G. A. Perrin. 2, W. G. Mulligan (Black Red). c, F. H. Green; R. Long. **POLANDS**—*Silver-crowned Spangled*—1 and 2, F. H. Green. 3, G. A. Perrin. *any other Variety*—1, F. H. Green. *Chickens*—1, W. G. Mulligan. 2, G. Martin. **TURKEYS**—1, Marquis of Downshire, Hillsborough Castle (Cambridge). **GEESSE**—1, G. A. Perrin. 2, W. G. Mulligan (Toulouse). *hc*, G. A. Perrin. c, W. G. Mulligan (Toulouse). **DUCKS**—*Aylesbury*—1 and 2, W. G. Mulligan. 3, R. N. Batt, Belfast. *Ducklings*—1 and 2, W. G. Mulligan. 3, W. Charley, Dunmurry. *Rouen*—1 and 3, W. G. Mulligan. 2, R. Long. *hc*, G. Martin. c, G. Martin. *Ducklings*—1, W. G. Mulligan. 2, G. Martin. **PUZZLE CHALLENGE CUP**—For the winner of the greatest number of points in the Poultry Classes. Points to be counted as follows:—viz. For each First Prize, four points; Second, two points; Third, one point.—W. G. Mulligan.

JUDGES.—Mr. A. Paterson, Chapel Street, Airdrie, Scotland; and Mr. A. Glass, Ayr, Scotland; and Mr. J. Dixon, North Park, Clayton Bradford.

INTRODUCING LIGURIAN QUEENS.

A FEW days previous to the receipt of two imported Ligurian queens, kindly obtained for me from Switzerland by Mr. Woodbury, I made two artificial swarms from old stocks of black bees.

I received the queens on the 2nd of June, and at once introduced them to their future subjects, taking the precaution, however, in accordance with Mr. Woodbury's suggestion, of imprisoning them, each in a little wire cage (a pipe cover), before placing them between the brood combs. At the expiration of twenty-four hours I released the queens, and setting them free allowed them to run away and conceal themselves from view in a cluster of bees, each in her respective live. Presuming that they were well received, and that they commenced laying eggs at once, it was to be expected that worker bees, the produce of the imported queens, would be hatched on or about June 23rd, and accordingly I have been upon the watch for them ever since that date. Yesterday (27th of June), I had the great satisfaction of observing young bees beautifully marked, and in considerable numbers, clustering upon the combs and contiguous to the glass back or door of the hives, thereby assuring me of the perfect success of this highly interesting experiment.

To-day (28th of June) in the bright sunshine, as I write, these young bees are playing about at the entrance of the hives. Both of these stocks are so very strong that it is not improbable that they may send forth a natural swarm; and although the proverb speaks disparagingly of a July swarm, yet my experience is that such a swarm, with a little careful nursing and feeding in the autumn and early spring, will form in the following year as thriving and populous a stock as does a swarm that has issued in May.

I may add that up to the present time the honey season in this locality (Honiton) has been exceptionally favourable. I have a glass super, the capacity of which is about 2 cubic feet, and which is now completely filled with honeycomb. I estimate its weight at not less than 100 lbs. The stock of bees, of which this super is the produce, consists of an artificial swarm taken last year from a stock into which a Ligurian queen imported from Como was introduced in the previous year.—RECTOR.

BEES LEAVING THEIR HIVE.

HAVING purchased a beautiful Italian queen last autumn, guaranteed not more than a month old before importation, I successfully united her to a well-provisioned black stock of bees, and saw young Italians in December. They continued to increase until February, when they gradually decreased until the beginning of this month (June), when the few remaining bees, with the queen, left the hive and alighted close by. I immediately captured her majesty and restored her to the deserted hive, and the bees returned quietly, but the next day left again, flew away, and were entirely lost. They left two combs with brood in every stage of progress, also honey and pollen, but no drone brood, neither did they ever breed any drones. I hived a black swarm of bees the next day in the deserted hive and combs, and they are doing well. What was the cause? The Italians did not do the same. Are the Italians better bees for breeding and gathering honey in this country than the common black bees?—A. A.

[This appears a very inexplicable occurrence. From whom did you obtain the queen, and how was the vendor enabled to guarantee her exact age when imported?]

EARLY SUPERS.—With reference to recent letters on this subject in the Journal, it may interest some of your readers if I

give the result of my own experience. On the 7th May last, I placed a super box on a Stewarton hive. It had in it a small piece of last year's comb, and perhaps a pound of honey. I removed this super on the 25th May, exactly three weeks afterwards, and it contained 18½ lbs. of honey, nett weight.—RICHARD MILLS, *Swanley, Kent.*

BAR FRAMES VERSUS EARLY SUPERS.

REFERRING to the account of an early super in Nos. 481 and 482, JOURNAL OF HORTICULTURE, it might be interesting to some of your readers to learn that I have this year used no supers of any kind, and nearly all my hives are Pettitt's bar-frame hives, with the ten and the thirteen frames. On the 15th June I took from one of the ten-frame hives (which was a stock transferred from a straw hive this spring), six of the frames well filled with honey and well sealed over, the six combs weighing 39½ lbs. In exchange for the six full frames I put in six empty ones, which I find on examination to-day are nearly all full, and will in a few days, I think, realise a similar weight; but I shall not take more than five combs in this instance, leaving the bees five for their use during winter. I have generally considered five or six of these bar-frames sufficient for their consumption in winter, and they contain about double the comb-building space that is found in some of the common straw hives.

On the 15th of June I went to the hive above referred to with the intention of forming from it an artificial colony, but found the combs so full of honey that there was no room left for brood, and in all this ten-frame hive there was none found, excepting on one comb about 3 inches square, which was occupied by brood on either side, or about 18 square inches. I therefore thought it best to appropriate the six combs to my own use, and try on the other six rather than to make a swarm with so little brood in it.—SUDBURY.

VEGETABLES BETTER THAN NOTHING.

[W SHOULD THINK so!—EDS.]

UNDOUBTEDLY great sustenance can be derived from vegetables. Vegetarians can give us many examples to prove that not only will vegetable matter alone sustain life, but that meat is injurious. Without going so far, I limit myself to one or two instances, proving that we are not absolutely dependent on meat, and that in its absence, or a very small quantity of it, good health and strength can be secured. Volney, a well-known though not a recent authority, describes the Wallachians in his travels as "tall, well-built, robust, and of a very wholesome complexion, diseases being rare among them." Further on we are told, "the manners of the Wallachians, as far as I have been able to judge them, are simple, and neither embellished nor sullied by art. Temperate in their repasts, they prefer vegetables to fruit, and fruits to the most delicate meat." The miners in Belgium furnish another good example. They eat, according to a report made in the locality, 2 lbs. of bread per day, about 2 ozs. of butter, 1 oz. of coffee and chicory mixed, while for dinner they have in the evening a portion of vegetables mixed with potatoes, weighing at the most 1½ lb. They have meat on Sundays and festivals, but during the week they drink neither beer nor other fermented liquors. Coffee is their only beverage. Yet these workmen are hardy and healthy. It is not the coffee which sustains them, for it constitutes but 1-35th of the nutritious property of their aliment, though M. de Gasparin, in a paper read some years ago before the French Academy of Sciences, attempted to prove, from certain tables, that the waste in liquid excretion is less when coffee is drunk than at other times. The miners' coffee is not like the French *café au lait*, for it has but 1-10th part of milk in it; he drinks several pints in a day, and eats only bread and butter until the vegetable meal of the evening. The albuminous substance which enters into the rations of the Belgian miner is thus reduced from 23 grammes to 15 grammes of azote. This is less nutritious even than the diet of the monks of La Trappe at Aiguebelle. Here is, therefore, proof that life and health can exist throughout a whole population with less nutritive substance than is generally considered necessary; that meat can well be replaced by vegetable and farinaceous matter. But it will be argued, that the impoverished British workman and pauper will object to the diet of the Belgian miner. In answer, however, might it not be suggested that the Belgian acts with greater wisdom when he preserves his health and spirits even on such a miserable diet,

than the Englishman who, constantly aiming at nothing less than the sirloin, falls short of the goal, and consoles himself with spirituous liquors? There is fortunately a medium course, and much despair might be avoided if our poor, and indeed some of the lower middle classes, knew better how to combine vegetable substances, and produce excellent meals, without any assistance at all from the butcher. Occasionally a good wholesome vegetable diet would be better than nothing; and, by refreshing the blood and assuaging thirst, would lessen the temptation of drink, always so great in moments of feverish anxiety, poverty, and want. Without adopting the miner's diet, many a good meal can be made for a few pence from vegetables, cooked with more heart than at present shown. It would take too long to analyse all the different vegetables at hand; but I will, on a future occasion, return to the subject, and for the present content myself with a few practical examples illustrative of my meaning.

For a cheap, yet tasty and substantial dish, let me suggest that the housewife grate two carrots, two turnips, one parsnip, a little beetroot and artichoke into one pint of split peas, boiled in two quarts of soft water for two hours. The whole might then be boiled with three teaspoonfuls of Indian, wheat, or Scotch meal, mixed in cold water, leaving it to simmer together for two hours more; a little parsley, mint, and thyme will flavour the dish. More water might be added if necessary. This somewhat complicated "hodge-podge" would well satisfy a middle-class family, and cost less, at any rate, than a joint. It would not do, perhaps every day, but might occasionally save the meat and avoid the horror at stinting at dinner. For a cheaper dish, why should not the lentil be introduced for everyday use in England as in France? For instance let a pint of lentils be soaked in pure soft water for twenty-four hours, then put in a stewpan (earthen or enamelled is best), and boil for four hours. Then two onions, one parsnip, one carrot, a little parsley, thyme cut small, and a small quantity of boiled rice should be added. This, mixed and boiled a short time together, would produce a satisfying and savoury dish, somewhat better than the diet of the Belgian miner, and yet very cheap. Lentils are about the most nutritious vegetable we possess. In 100 lbs. they contain 84 lbs. of solid matter, and 16 lbs. of water, of which 33 lbs. are flesh-forming, and 48 of heat-forming principle; while butchers' meat, according to Baron Liebig's table, has but 21.5 lbs. per cent. of flesh-forming principle, and 14.3 that gives heat. The rice has 82 per cent. of the heat-forming principle. Compared with these, the other vegetables are more useful as giving water, flavour, and rendering the dish light and digestible. The celebrated Indian and Chinese dish called *dahl*, has also lentils for its chief ingredient, and is purely of vegetable matter. It is substantial and delicious, and is made as follows:—Stew a quart of split lentils till they form a thick soup; have ready a pound of rice, well boiled in milk, and drained off as dry as possible. Shake the rice up loosely in a dish, and, after mixing an ounce of curry powder with the lentils, pour the lentil soup over the rice and serve it up. Dishes, cheaper even than these, may be made palatable.

Before concluding, however, there is one important objection which has often been made, through ignorance of the first rule in cooking vegetables. It is observed that a meal from them is not satisfying. I have found it frequently happen that the person who thus objected, did not know even how to boil a vegetable. The rule is simple, but must never be forgotten. Every kind of vegetable intended to be served whole should, when put to boil, be placed at once in boiling water; and this applies especially to potatoes, and vegetables from which the outer cover has been removed. Now it often happens that potatoes, &c., are, to save time placed in cold water and left to boil gradually. It is just this which allows the nutritious matter to escape, and renders the meal unsatisfying. When, on the contrary, the water boils from the moment the vegetable is immersed in it, the albumen is partially coagulated near the surface, and serves to retain the virtue of the vegetable. The reverse is, of course, the rule for making soup, or any dish from which the water will not be drained. By placing the vegetables in cold water the albumen is slowly dissolved, and actually mixes with the water—a process most necessary for the production of nutritious soup. It is to be hoped that the poor, who have a special need for the most their money can produce, will learn, in whatever haste they may be, not to boil all the albumen from their potatoes, reserving for their meal only the starchy matter.—(*Food Journal.*)

OUR LETTER BOX.

SEPARATING CHICKENS (C.B.).—The time at which you require to breed stock birds must influence you in separating your chickens. There is, however, no fear if they are but two months old. As a rule with birds of

that age, October will be soon enough. The curd was fully described in one of our early numbers of "Rational Poultry-keeping" (see page 365 of last volume). If you do not mean to breed again from the parent cock, the sooner he is removed the better.

INFLAMED EGG-ORGANS (*Psewich*).—We cannot better answer your question than by giving the following quotation from the "Poultry-keepers' Manual":—"Symptoms, the hen goes on to the nest without laying; having a straddling gait; laying shell-less eggs; dropping eggs from perch or elsewhere. Cause, overfeeding. Another cause is eating the seeds of grapes, or grain affected with ergot. We once knew a yard of Dorkings having an extensive grass run. They all laid shell-less eggs, and the pellets evidently had over-excited egg-organs, the eggs were distorted, and added eggs, almost without exception, characterised every sitting. We believe the seeds of the grasses were affected with ergot. It may be necessary to explain to some of our readers that ergot is a fungoid substance, which completely changes the composition of the grass seed which it attacks."

EGGS OF PIGEONS FOR SALE (*Gls-pe*).—We have only known Pigeons' eggs to be bought by boys at the bird shops, the dealers not wishing the Pigeons to breed in the cages. We should scarcely think valuable eggs are to be bought, as the bird laying but two, there are none to spare.

EXHIBITING DISEASED PIGEONS (*Constant Reader*).—We think that diseased birds, of whatsoever sort they be, ought not to be exhibited for many reasons, such as fear of contagion, unsightliness, &c. The Carrier alluded to must have been by far the best bird, so the judge acted rightly. It was for the committee to have interfered, as they make the rules.

CARRIERS AT SPALDING.—Mr. Massey says we printed his notes erroneously, and that the line commencing "I rather gave the preference, &c.," refers to Mr. Ord's bird, and not, as it now reads in the printing, to Mr. Filton's.

COCK CARRIER PIGEONS AT SPALDING (*An Exhibitor*).—Perhaps it was a mere mistake of the printer of the prize catalogue, and it ought to have been printed thus—"three years," instead of "three months."

FOOD FOR YOUNG SKYLARKS FEEDING THEMSELVES (*A Subscriber*).—German paste, stale bread crumbs, and the yolk of hard-boiled egg, mixed together; fresh water should be given separately, and as they grow larger, supply occasionally two or three mealworms and a few ants' eggs. Barley meal should not be given.

YOUNG NIGHTINGALES (*Idem*).—The yolk of hard-boiled egg, raw beef chopped fine, stale bread crumbs grated fine—the same as put on fried soles—mixed together, and about two mealworms a day; occasionally a few ants' eggs. As they grow older they will require more mealworms. There are very few British and foreign birds that will agree together in an aviary.

CANARIES NOT SINGING (*T. S. J.*).—The fact of the Canaries being placed so that they can see each other ought not to interfere with their singing. On the contrary, if they are in health and "fresh," they should sing one in opposition to the other, rather than maintain a prolonged silence. You can solve the question for yourself by altering the position of the cages; or if that be inconvenient, nothing can be more simple than to cover one side of either cage so that the respective tenants cannot take stock of each other. In their privacy they might be indeed to compare notes—that is very nearly a pun! Discontinue the bread and milk, and boiled carrot and egg—in fact, all messes. More birds are injured by over than by under-feeding. Give only canary and rape, with such green food as may be in season.—W. A. BLAKSTON.

COCK GOLDFINCHES TAPPING THE EGGS (*C. S. De Witt*).—The nest suggested by our transatlantic correspondent is a modification of one long in use among Mule-breeders here. I refer to what is known as a "drop-nest." It is simply an ordinary circular tin nest box, in the bottom of which there is a hole, and to the bottom is attached a tin box containing cotton wool, swan's down, or any soft material, into which the egg falls. This box or canister is easily detached from the nest, and the egg can then be removed. I would not advise the substitution of a cloth receptacle, for both birds will be unceasing in their attacks on it, one in quest of a shred or two for her nest, and the other from sheer mischief. The first contrivance of the kind I attempted was a combination of a tin nest and the leg of one of "Jacky's" stockings, which I purloined for the purpose. I thought my apparatus was perfection: unique it certainly was. Next day I found my little stocking hanging in threads surrounded by a very neat nest manufactured from the ruins, but no egg. My impression was then and is now, that the Goldfinch knew something about the disappearance of that egg. He was in fine voice that morning (of course, owing to the raw egg), and as he sat on the edge of the nest, woven with infinitely more skill than the poor little stocking, he gave such sly looks and such whisks with his tail, that one was driven to the conclusion that he was crowing over the demolition of the bag and the abstraction of its contents. No one ought to attempt Mule-breeding without having his head phrenologically examined, and if patience and hope be not largely developed, do not begin. Too much care cannot be taken of a Mule-egg. Who knows what it may produce? I never yet knew one to be broken but a prize bird was considered as lost. The hatching of each succeeding nest gives rise to the wildest surmises as to the value of its contents. Daily and hourly the faintest dark speck is looked for, and I have even surprised an enthusiast in his sanctum making microscopic investigations. But nothing can exceed the happiness of that man who, after a fortnight or three weeks of most anxious suspense, can quietly compose himself in his arm-chair, coolly comb his beard, sip his coffee, and announce to eager inquirers "One even-marked and two clear in one nest!" And who shall tell the disappointment of the man who has—this season—bred fifty dark ones?—W. A. BLAKSTON.

COMMENCING BEE-KEEPING (*Marian*).—Purchase from any neighbouring bee-keeper one or more first swarms which issued in May. It will, however, be best to defer their removal until autumn; but if you are too impatient to wait, they should be tied up in cloths of open texture (cheesecloth), and removed very carefully in the cool of the evening. If you can agree with the vendor to do this at his own risk, so much the better, as the combs, being at this time new and heavy, are liable to fall if the hives are roughly handled.

SPERRING AT THE TIME OF HIVING (*A Regular Subscriber*).—Much depends upon the size of the super. If it be but a small one, you have only followed the example of many apiarians, who advise its being put on when the swarm is first hived. We, however, think it best in any case

to defer it for a few days after hiving, so as to insure the new colony first commencing operations in the stock hive. The super should be removed when full, or at any rate as soon as the honey harvest is over, as it would do more harm than good to allow it to remain on during the winter. If, when a super is removed, the bees which it contains soon fall into confusion, and begin to return to the stock hive, all is probably right; but if, on the other hand, they remain quiet, whilst a commotion arises in the hive itself, the queen may have presumed to be in the super, which in this case should be returned, and the operation deferred until some more favourable opportunity.

ARTIFICIAL SWARM (*T. Jacobs*).—What we advised was to form an artificial swarm by driving all the bees of one stock into an empty hive, and then to repeople the deserted hive by putting it in the place of another stock. What you appear to have done is to drive out a part, or, perhaps, nearly the whole of the bees, without taking any steps towards rearing the exhausted population. Under these circumstances it is difficult to predict the ultimate result. From what you state, it seems most likely that the queen accompanied the expelled bees, and therefore if the remainder of the season be favourable, there seems no reason why the swarm should not do well. With regard to the old stock, the matter is far more uncertain. If sufficient bees remain to hatch out the brood, a queen will, probably, be reared, and all may be right. If, on the other hand, the remaining population is too scanty, most of the brood will become chilled, and the colony will be ruined. Should the stock survive until the autumn, it will, doubtless, be benefited by adding to it the bees of a condemned colony.

DRONE SLAUGHTER (*Dawlish*).—A general massacre of drones shows that the honey harvest is now at a standstill, but it does not prove that the cessation is more than temporary.

SUCCESSFUL SWARM (*R. B. N.*).—A swarm hived on the 2nd of June, and having gathered 24 lbs. of honey and wax by the 23rd, has done well.

METEOROLOGICAL OBSERVATIONS

In the Suburbs of London for the week ending July 5th.

DATE.	BAROMETER.		THERMOMETER.				Wind.	Rain.
	Max.	Min.	Air.		Earth.			
			Max.	Min.	1 ft.	2 ft.		
Wed. . . 29	29.991	29.971	76	43	62	58	N.	.00
Thurs. . 30	29.977	29.961	72	41	62	58	N.W.	.03
Fri. . . . 1	29.945	29.936	68	36	61	58	N.W.	.00
Sat. . . . 2	29.937	29.896	72	97	59	57	N.W.	.00
Sun. . . . 3	29.884	29.817	64	52	59	57	N.W.	.04
Mon. . . 4	29.945	29.728	81	61	61	57	W.	.00
Tue. . . . 5	29.910	29.893	71	59	64	58	W.	.10
Mean . .	29.941	29.873	72.00	47.00	61.14	57.57	..	0.14

- 29.—Very fine; cloudy hot fine; clear starlight.
- 30.—Cloudy; fine, heavy clouds; densely overcast.
- 1.—Fine, cloudy; fine; slight showers.
- 2.—Overcast; cloudy but fine; clear and fine.
- 3.—Densely overcast throughout; rain at night.
- 4.—Densely overcast; damp; cloudy; overcast.
- 5.—Densely overcast; drizzling rain; overcast, strong wind.

COVENT GARDEN MARKET.—JULY 6.

MARKETS are generally well attended, and a fair amount of business doing, the supply of soft fruit having much improved during the past week. Hothouse produce is ample, Pineas and Grapes being largely supplied at lower prices. Continental goods comprise Peaches, Nectarines, Apricots, Melons, Cherries, and Figs.

FRUIT.

	s.	d.	a.	d.		s.	d.	a.	d.
Apples.....	1	6	2	0	Mulberries.....	quart	0	0	0
Apricots.....	doz.	2	0	4	Nectarines.....	doz.	6	0	12
Cherries.....	lb.	0	6	1	Oranges.....	per 100	7	0	14
Chestnuts.....	bushel	0	0	0	Peaches.....	doz.	10	25	0
Currants.....	1/2 sieve	4	0	0	Pears, kitchen.....	doz.	0	0	0
Black.....	do.	0	0	0	dessert.....	doz.	0	0	0
Figs.....	doz.	6	10	0	Pine Apples.....	lb.	3	0	0
Fibers.....	doz.	0	0	0	Plums.....	1/2 sieve	0	0	0
Cobs.....	lb.	0	9	1	Quinces.....	doz.	0	0	0
Gooseberries.....	quart	0	4	0	Raspberries.....	lb.	0	6	1
Grapes, Hothouse.....	lb.	3	0	8	Strawberries.....	lb.	0	6	2
Lemons.....	per 100	8	0	14	Walnuts.....	bushel	10	16	0
Melons.....	each	3	0	8	do.....	per 100	1	0	2

VEGETABLES.

	s.	d.	a.	d.		s.	d.	a.	d.	
Artichokes.....	doz.	3	0	6	0	Leeks.....	bunch	0	4	0
Asparagus.....	per 100	3	0	8	0	Lettuce.....	doz.	0	6	1
Beans, Kidney.....	do.	1	0	1	6	Mushrooms.....	potlde	3	0	4
Broad.....	bushel	3	0	0	0	Mustard & Cress.....	punnet	0	3	0
Beet, Red.....	doz.	0	0	0	0	Onions.....	bushel	4	0	0
Broccoli.....	bundle	0	0	0	0	pickling.....	quart	0	4	0
Brussels Sprouts.....	1/2 sieve	0	0	0	0	Parsley.....	sieve	3	0	0
Cabbage.....	doz.	1	0	2	0	Parsnips.....	doz.	0	9	1
Capsicums.....	per 100	0	0	0	0	Peas.....	quart	1	0	1
Carrots.....	bunch	0	4	0	8	Potatoes.....	bushel	4	0	7
Cauliflower.....	doz.	2	0	6	0	Radishes.....	doz.	6	0	0
Celery.....	bundle	3	0	0	0	Rhubarb.....	doz.	3	0	0
Colewort.....	bunches	3	0	0	0	Rhubarb.....	bundle	0	4	0
Cucumbers.....	each	0	6	1	6	Savoy.....	doz.	0	0	0
pickling.....	doz.	2	0	4	0	Sea-kale.....	basket	0	0	0
Endive.....	doz.	2	0	0	0	Shallots.....	lb.	0	6	0
Fennel.....	bunch	0	3	0	0	Spinach.....	bushel	3	0	0
Garlic.....	lb.	0	8	0	0	Tomatoes.....	doz.	1	0	3
Herbs.....	bunch	3	0	0	0	Turnips.....	bunch	0	1	0
Khorradiah.....	bundle	3	0	6	0	Vegetable Marrows.....	doz.	4	0	0

WEEKLY CALENDAR.

Day of Month.		Day of Week.		JULY 14—20, 1870.		Average Temperature near London.			Rain in last 48 years.	Sun Rises.	Sun Sets.	Moon Rises.	Moon Sets.	Moon's Age.	Clock before Sun.	Day of Year.		
				Day.	Night.	Mean.	Days.	m.	h.	m.	h.	m.	h.	Days.	m.	s.		
14	TH	Newcastle (Staffordshire)	Horticultural	74.5	50.5	62.5	15	1	4	10	af	8	31	af	9	16	5 32	195
15	F	St. Swithin's Day.	(Shew.)	76.6	50.7	63.7	22	2	4	9	8	0	10	35	6	17	5 38	196
16	S			76.0	50.1	63.0	17	3	4	8	8	24	10	47	7	18	5 41	197
17	SUN	5 SUNDAY AFTER TRINITY.		74.3	51.3	62.8	16	4	4	7	8	43	10	59	8	19	5 49	198
18	M			74.7	50.2	62.5	21	5	4	6	8	3	11	7	10	20	5 54	199
19	TU	Royal Horticultural Society's Oxford Show		73.2	49.9	61.1	22	6	4	5	8	19	11	14	11	21	5 59	200
20	W		opens.	73.2	50.2	61.7	23	7	4	4	8	39	11	after.	11	21	6 2	201

From observations taken near London during the last forty-three years, the average day temperature of the week is 74.6°, and its night temperature 50.4°. The greatest heat was 94°, on the 17th, 1894; and the lowest cold 33°, on the 17th, 1863. The greatest fall of rain was 1.60 inch.

PRUNING ORNAMENTAL TREES AND SHRUBS.

No. 4.



HAVING in previous papers treated at considerable length on pruning Conifers and the forms most suitable, I have chosen for my third section the most serviceable of all evergreen shrubs.

Section III. consists of Hollies, Laurels, Sweet Bay, Laurustinus, and Box. As specimens on lawns or at the sides of walks I know of no equals to them. They can be pruned to any extent, and in a short time

will be as green and well covered with foliage as ever; and they can be formed into cones, pyramids, round bushes, or any other shape, and be kept to it with the smallest possible increase in size; hence their adaptability for architectural gardens. The subjects comprised in this section are well worthy of separate note; therefore I shall commence with the Holly, which admits of three different modes of pruning, or rather training, to secure—1st, cones or pyramids; 2nd, bushes; 3rd, open natural trees.

Hollies as Cones or Pyramids.—Man can aid in producing more beautiful objects than Nature left to herself, but he cannot cause a subject Nature has decreed shall be a pyramid to become a handsome bush. Mr. Rivers, the father of close pruning or summer pinching, has found out that: some kinds of fruit trees, he tells us, are not adapted for bushes, but they form handsome pyramids, and the contrary also holds true; and so it is with Hollies. All may be formed into cones, but it is by a very close cropping of the side shoots, and the subjects thus treated never have a natural appearance; they are on a par with standard Roses—the acme of ugliness.

Good sorts of Hollies for cones are I. Aquifolium, Aquifolium femina, Aquifolium flava, altaclerensis, balearica, glabra, Hodginsi, maderensis, and Shepherdi. All except the first three have splendid broad leaves; the best are Hodginsi, maderensis, and altaclerensis; the first of these will form a fine avenue when planted by the sides of a broad walk.

Of the variegated sorts, the gold and silver-edged are the best two; then Handsworth New Silver, Gold and Silver-blotched, and the Gold and Silver Queen's, but none outvie the two first-named and oldest.

Cones or pyramids of any of the above are secured by, as might be expected, cutting in the sides and encouraging the top. The trees almost invariably grow more strongly at some distance from the ground than near it: hence the necessity of securing branches near the ground or base of the tree while it is young, for if not produced then they cannot be obtained after the tree is of good size. The greatest difficulty is in securing a good leader and keeping it perpendicular. If the trees are required to form close pyramids, a strong growth in the leader is a disadvantage rather than a gain, as with a vigorous leader we have the side shoots considerably further apart than when the growth is not very strong. I consider it well to select for pyramids trees with straight stems, and with the branches

set on near the ground, and the pruning of the side shoots should begin when these have extended about 1 foot from the stem. Then take off their points, and a string fastened to the end of the shoot, and extending upwards to a height of 3 feet, and brought to the centre of the tree, will show to what extent the side shoots are to be pruned, none being pruned closer to the main stem than 3 inches; the leader being 6 inches above where the side branches are cut back to 3 inches. This being done, we shall have trees about 4 feet high, half that through at the base, and gradually tapering upwards. Care should be taken to have the centre erect, the cone from the base tapering upwards all round. The best time to prune is just before the trees begin to grow, and they will not require any further pruning the same season than the stopping of any irregularity of growth, which it is better to do in time; for by stopping a strong shoot during its period of growth we induce greater vigour in those shoots remaining un-stopped, and have a greater chance of obtaining in the stopped shoot growth of the character required.

The following spring the tree will need to be gone over, and the side shoots cut in, or such of them as have extended beyond an extent corresponding to the others; and as we may in a vigorous, healthy tree calculate on about 4 inches of annual increase in the growth, we must shorten the lowest shoots to that length, and with a line from them, as before, to the apex or top of the leader or tree, it will be readily seen to what extent the side branches will require shortening. We have in this case a greater increase of the tree at its base than in its upper parts. The top will always be the strongest, therefore cut in the top most, and the lower part will become well furnished: this effected, we can easily furnish the top. If the leader deviate from the perpendicular, either cut it away to the point where it is in the centre—and this is the best plan if the leader is very strong—or secure it in the centre with a stake, the latter mode being desirable when the tree is growing weak in the centre. The whole art in pruning Hollies in the form of cones is to cut them to that form every spring, and leave the rest to nature. The trees will sometimes put out strong shoots from the main stem or branches, and those having an upward tendency, or growing over shoots they must enfeeble, should be rubbed or cut off close to the part whence they proceed. The trees will not have an equal amount of branches all round—some parts will be thick, others thin; therefore, in pruning, thin out the most crowded parts of the tree, and cut the thin parts but little or not at all, only pruning enough to preserve the required shape. Open spaces or sunk parts should not have the shoots shortened, but be allowed to grow until the space is filled up.

Bushes are formed by restraining the upper part or centre of the tree, the shoots there not being permitted to grow erect, except for the extension of the plant. To secure a close growth near the base it is necessary that the head be taken off at the height of 2 or 3 feet from the ground, and the side shoots ought not to be stopped until they are distant from the stem half the height of the tree. This will afford the basis of a half sphere. All that is required

beyond this is to cut off the irregular-growing shoots in spring, commencing with those near the base; in fact, this ought to be done whenever there is a deficiency of vigour in the weak shoots, which, for the most part, are at the base of the tree. The pruning of those parts should be done about a fortnight or three weeks in advance of the pruning of the shoots in the upper part of the tree. This will cause the lower shoots to form buds, or, it may be, start them ere the shoots at the upper part are pruned, so that when the upper shoots are shortened the lower shoots will start freely, making more vigorous growths than if they were pruned at the same time as those at the upper part. Pruning is not necessary every year, so long as the form required and close growth are secured, and yet it is well to go over the bushes periodically and do whatever is necessary; for nothing is so ugly as an irregular-growing bush Holly. Beyond restraining the growth upwards, the pruning of bushes is not materially different from that of pyramidal trees.

Open natural-shaped Trees.—These are best with one leader, though it is not uncommon to see them with two or more, and in a state of nature they usually have several. Now, if the tree is young, there is no excuse for more than one leader, and being kept to that, the side shoots will only need to be shortened where too long in proportion to those in another part, thinning them out where too crowded, in order to encourage growth in the weak and open parts of the tree. Care should also be taken to cut out all shoots or branches that cross each other, or which, from growing upright, are likely to interfere with the leader or with the vigour of the side branches.

In case of two or more leaders having been formed it will be necessary to see to their vigour being equalled, which may be secured to a great extent by cutting in the strongest in spring after growth has commenced, and not pruning the weakest that season. It will also be necessary to prune the side branches so as to give an equal extension to them, and to preserve the balance between all the parts of the tree.

Those having Hollies that are too spreading and too loose, taking up more space than is desired, and badly formed, will do well to have them pruned into shape. The end of March or beginning of April in a mild season, or a fortnight to three weeks later if the season is late and cold, is the most suitable time. Hollies will bear pruning to any extent, but of course break most freely from the smaller branches. The strongest shoots or branches should be cut back more, and the smallest least, for if they are all cut off to one length the strongest will push much more vigorously than the weak, and soon be more extended; hence they should be cut well back, or say a foot more than a branch half their thickness. The small shoots should be cut back evenly, so that there may be as nearly as possible an equality in the growth the first season. The very weak branches, and those which cross each other or grow upright, should be cut well in, and, if need be, cut clean out. To secure good growth, well thin out the branches; they do no good crossing and overlying each other. If the weather prove dry in May and the beginning of June give a good watering, and the growth before autumn will be good, and the following year handsome trees will be the result. I have cut Hollies that had a very large spread of head so closely in that there was little but sticks left, and have surprised those asking for their removal as wondrously objects with the handsome pyramids or bushes secured by a judicious use of the saw and knife. I have seen old spreading open trees formed into pyramids and bushes so close that birds had to seek an entrance from beneath.
—G. ABBEY.

NOTES ON ROSES. AND THEIR CULTURE.

MR. RUDOLFF has spoken in such glowing terms of Felix Genero that I think it right, in order that amateurs who have not seen the Rose may not be disappointed in ordering a great number, to say that I do not think the opinion of Rose-growers in general would bear out Mr. Rudolff's estimate of it. It is, no doubt, a good grower, but the colour is dull (red, with too much of a violet tinge in it), and the shape by no means first-class. The outer petals are never large enough. It is more of the form of Prince Henri de Pays Bas, which, though I know it is admired by some Rose-growers, does not approximate a high standard in shape. The only thing, in my mind, to recommend in the shape of Felix Genero is, that having incurved petals it hides its own deficiencies, as I have never yet picked a flower of it that was very full in the centre, if the incurved petals were pushed back to examine it. It would be interesting, I think

if Rose-growers were to classify their Roses under their different forms, taking well-known Roses as standards of form—as, for instance, Alfred Colomb, Comtesse de Chabillant, Baronne de Rothschild, Louise Margottin, La Ville de St. Denis, &c. I hope some of our best observers of Roses, as the Rev. S. R. Hole and the Rev. E. N. Pochin, will do so, and if new Roses, when they came out, were described in this way, as to their shape, it would very much help persons who wished to order some of the new sorts.

While on the subject of Roses, I add, hardly any Rose has done so well or improved so much with me this year as Princess Mary of Cambridge. Fisher Holmes has also gained much in my estimation, and Madame la Baronne de Rothschild is almost perfection as a pink. La France has also been very fine, though too loose in the petal; and Annie Wood has had some exceptionally fine flowers. I never remember to have seen dark Roses burn so much as this year. I can hardly get a Rose from Monsieur Boncenne, Lord Macaulay, Duke of Wellington, or Pierre Notting which is not burnt, and I am thinking another year of planting all very dark Roses by themselves in a quarter in my kitchen garden, and fixing up some framework of laths, so as to be able to cover it over entirely with tiffany on very sunny days. Those that have no shade of purple in them, as Alfred Colomb, Marie Baumann, Le Rhone, La Brillante, &c., can stand the sun, and so do all the cerise, pink, and pure white Roses; and it is one great point to recommend pink Roses, that they seem to last much longer than dark Roses, either crimson or scarlet. For instance, Princess Mary of Cambridge, Abel Grand, and Baronne de Rothschild keep their true colours and last longer than almost any Roses I am acquainted with. There are other Roses which ought to be grown in the shade as well as the dark ones; for instance, Souvenir de Malmaison and Gloire de Dijon are both of them improved both in form and colour in hot summer weather if they are well shaded. Souvenir de Malmaison, especially, should never be exposed to full sun. Miss Ingram, again, and Acidalie, also seem better for a slight shading.—C. P. PEARCE.

TABLE DECORATIONS.

IF I refer to this subject again, it is not because I have seen any reason to alter my opinions, or that I can throw any fresh light on it, but because I have had the opportunity of seeing since I wrote last two examples of decoration, one showing how it ought to be done, and the other just the opposite. I allude to the arrangement made at the Rose Show at the Crystal Palace by W. Thomson, Esq., of Penge, and the other at the Royal Horticultural Society's Rose Show. The former was almost perfect in its way; the latter, with the exception of that which obtained the first prize, as bad taste as it was possible to be.

The exhibition which had been made by Mr. Thomson was in the large theatre, which had been altered for the purpose, and consisted of one large dining table and two smaller ones, the two smaller ones being arranged by professional artists, the centre one by amateurs. It is to this centre arrangement that I desire to draw attention, and although it is quite impossible to describe it, yet I shall endeavour to give a brief sketch of it. The table was large—probably would dine twenty people—and was a long oval. As the cloth is never removed now-a-days, the old tale of sitting under one's mahogany may be considered as exploded, and any kind of wood may be used. In this instance the top was of deal, and in it holes had been made to receive flower pots containing Palms; instead of the ordinary tablecloths strips of Jamack are placed on, by this means the pots are concealed, and the Palms look as if they spring from the tablecloth itself; after they have been placed the cloths are ironed, and all looks perfectly smooth. Some seven Palms, I think, were placed on the table, the centre one being the tallest, and the others arranged according to height, the general height being about 3 feet. On either side of the tall Palm were very tall and graceful-looking glass vases, containing a few Fern fronds and some sprigs of the climbing Fern. On the outside of the Palms were six glass vases filled with Fern fronds and Pelargoniums. In some of them were flowers of Hibiscus, and this was almost the only piece of coloured flower in the entire arrangement. To give colour, coloured wine glasses, two to each plate, were used, and coloured finger glasses. This seemed to me to fulfil all the conditions of good taste, and to fall in with the canons I have laid down; for the arrangement was simple, there was no obstruction of the view, there were

no highly scented flowers used, and there was but little colour, what there was being quite adapted for its purpose. No faults of deep blues and glaring yellows were to be found there, all being in quiet and unstained harmony, yet I heard numbers of people complaining of too much green, want of colour, &c. There was but one fault to my mind, and as it was candidly acknowledged by the exhibitor I feel less compunction in noticing it. There was a want of something round the base of the Palm stems, as they looked too formal and unnatural coming out directly from the tablecloth. I see some one has suggested allowing the rims of the pots to appear, but this would seriously interfere with the tablecloth. It strikes me that semi-circular troughs of white ware, such as were used at the Palace, to encircle the base, and then to be fitted with Lycopodium, would be a desirable method of getting rid of this objection.

And now to the obverse of the medal. Prizes, liberal prizes, were offered by the President of the Royal Horticultural Society for table decorations, and yet there were only three competitors. The first deserved its prize; for although there was nothing original in it, it being, in fact, the arrangement that took second prize amongst amateurs at the Palace, yet there were no violations of taste. But why the Judges should ever have given anything to the second and third prize arrangements passes my comprehension. I can only explain it in one way—they were lady judges, and they lean to the side of mercy, and so would not disqualify; but it was hardly, in my mind, possible to find anything so thoroughly violating all taste. It was a vase filled with a considerable mass of the common white Lily, and the base with the white Water Lily; around it were placed some cardboard troughs containing single blooms of scarlet Pelargoniums. Imagine the faint and sickly smell of the Lilies in a heated atmosphere, and how utterly the white was lost on the white tablecloth, while the lumpiness of the arrangement would hinder, if there were more stands, any view that there might be across the table, and most certainly few people would desire to have such a stand before them for the length of a dinner. Let us hope—though giving prizes to such productions is liable to defeat it—that a more correct taste may lead people to copy better examples than the latter one.—*E. Deal.*

MORE ABOUT SOFT SOAP.

I AM glad the claims of this article as an insect destroyer are recognised in your number for June 30th by your able correspondents—"ANNANDALE," page 460, and "R. F.," page 467; and I hope others who have tried it will report the result, whether satisfactory or not. As my former communication has evidently been misunderstood by "ANNANDALE," and, on the other hand, I have since found I was led into an error about the price, to which "R. F." very properly calls my attention. I will endeavour to explain both. In the first place I may say that the strength of the wash made from this material, as used by the Hop-growers, is not so great as "ANNANDALE" himself advises—viz., 2 ozs. to the gallon, as 1 lb. to ten gallons (the Hop-grower's recipe) is little more than 1½ oz. to the gallon. Whether this be too strong for Peaches or not I cannot with sufficient authority affirm, as in the cases where we used it sufficient attention to weights and measures was not paid to be depended on; but if a less quantity of soft soap be required, so much the better, as it cheapens the solution, unless in seasons like the present, when twenty or thirty gallons of water may in some places be more costly than the pound of soft soap.

As, however, the price of the soap is the point to which general attention will be directed, I confess to having been led into an error through the imperfect formation of a figure, or other cause, by which the 2d. per pound should have been 3d., an important advance, which, probably, by the retail dealer will be considerably augmented. I have made further inquiries respecting the soft-soap trade, and have learnt from a friend keeping a shop in a country village (who, amongst his other manifold stores of food, clothing, and tools, also deals, or rather dealt extensively last year in this article), that it is usually made up into small casks, called firkins, weighing 64 lbs. each in the gross, being supposed to contain 56 lbs. of soft soap. These firkins he sold at from 14s. to 16s. each, and at the time the demand was for them, fifty or sixty firkins a day were not an unusual sale, and this at a country shop. The consumption of soft soap in the neighbourhood during the months of June and the early part of July last year was, therefore, very extensive. Fortunately for all but the dealers in soft soap, none has been wanted this year, the plant being clean, or but little affected by insects. I may add that I believe an

article cheaper than 14s. per firkin was often made use of, but at this price it is just 3d. per pound; but even if it were twice as costly, it will favourably contrast with any other insect-killing material in use if the sixpence so expended furnish ten, twenty, or thirty gallons of solution as the discretion of the party using it may suggest. It would certainly be prudent not to make it too strong for delicate plants, but I am far from certain that it is so dangerous as is represented; on the contrary, I believe it to be more harmless to vegetation than many of the mixtures so much recommended. Of this I shall be able to write with more confidence later in the season. Meanwhile I advise caution.

I have no hope of being able to say much on the application of this insect-destroyer to the Hop plant in the present year, for the fly has not made its appearance in sufficient quantity to require the antidote. Other enemies the Hop has, which I hope to refer to in a future communication; no plant that I know growing in the open air is so liable to misfortunes.

I may here mention one other quality which soft soap is said to possess, although I do so on general repute rather than from any well-founded experiments of my own, and that is, that the solution is a manure, which certainly cannot be said of some of the mixtures used as insect-killers. Others, however, will probably give information on the subject, and a few experiments could be easily tried to test its value as a manure, as well as to try the effects of solutions of different strengths on the foliage of plants.—*J. ROBSON.*

AËRIAL ROOTS ON VINES.

I DIFFER from Mr. J. Douglas (see last volume, page 419), respecting some of the causes of air roots on Vines. A close moist atmosphere, which is generally an accompaniment of early forcing, is what I consider to be their real cause. Vines exclusively planted in an inside border are those which the most frequently produce air roots, owing to the bottom heat driving the moisture upwards and causing a great density in the atmosphere of the house. This condition will produce air roots in abundance, if ventilation is not strictly attended to.

I have seen Vines which were planted in an outside border only, and started about the 1st of January, with about 3 feet deep of horse manure mixed with leaves placed on the border, produce better Grapes than those which had the advantage of bottom heat, and yet scarcely an air root was to be seen. I have likewise noticed Vines that have had the advantage of both an inside and outside border produce air roots freely one season and the next scarcely any. Would Mr. J. Douglas say how he accounts for that?

Vines that are cropped late will produce air roots freely enough if the foregoing condition be afforded—that is, a close moist atmosphere; but this state of things seldom exists, as air can then be admitted without such discrimination as is required in early forcing.—*QRO.*

OUR NATIVE FERNS.

I HAVE before me my friend Mr. E. J. Lowe's very beautiful work bearing the above title. I begin to think that "distinct varieties" are often made out of nothing at all. Two years ago I was watching a self-hunting dog; about midnight I kindled a match under the shelter of a thick bush where I was concealed, and to my astonishment the blaze revealed a magnificent plant of the Crested Male Fern, by far the finest I ever saw. Mr. Dickenson, who has been a botanist all his life, has, I believe, only once found it in Cumberland. This year it has come "blind" and all manner of shapes. Miss M. Wright, of Keswick, gave me one found by herself, and pictured in Lowe as *Lastrea F.-mas abbreviata cristata*. This year it has come perfectly plain and run back to the normal form. I have many similar communications to the same effect, which tend to show that such Ferns are not varieties, but monstrosities which sometimes recover.—*JACKSON GILLBANKS.*

POTATOES.—In answer to a correspondent, the Pebble White Potato has a white blossom. Pebble White, Crystal Palace Kidney, Edgecote Second Early, Yorkshire Hero, Beaconsfield Kidney, Huntingdonshire Kidney—all strains of the old Cobler's Lapstone—I have growing by its side, and their blossom and foliage are almost identical to a shade. All the numerous strains of the old Lapstone can scarcely be distinguished from

each other during their early growth; and, curiously enough, in my graft hybrids a change of foliage is now distinctly seen, excepting only in those of the grafted Lapstone family. I have about two hundred varieties of Potatoes growing here.—ROBERT FENN, *Woodstock Rectory.*

GREEN FLY ON CUCUMBER AND MELON PLANTS.

I AM sorry to hear that some correspondents have fumigated with tobacco and syringed with soft-soap water without any effect. I know of no better remedies for plants under glass, and when used in time I have always found them less or more effectual. No green fly will stand tobacco smoke when presented to it strong enough, but smoke will not hurt those just hatching into life, and even very young green fly will stand a dose which older fly will not. Unlike what takes place in other departments of life, I have generally found that in insect life the vital powers are strongest in proportion to youth, or even infancy. If the plants are pretty good I should recommend a continuance of the smoking and the washing. Perhaps it may be as well to allude to a few of the essentials to success.

1, The smoke must be kept in the place for a considerable time. Hence, unless the glass roof is very close, it should be covered, and litter or short grass placed at the top and bottom of the sashes, and then the glass and covering should be kept damp by syringing outside, which will fill all laps of the glass, and prevent the smoke escaping. It is better to shade than give much air the following day. Smoking is best done in the evening. With these precautions, 2 ozs. of tobacco will do as well as, or even better than, a pound when the smoke is allowed to escape.

2, All plants smoked should be dry as respects their foliage; not only is this necessary in order that the smoke may tell at once on the insects, but also that the smoking may be safe to the plants. The narcotic that kills the insects will also poison and destroy the plants if presented to them in excess, and more especially if the foliage is damp. I have a hazy conception in my own mind as to how this is, but it is not quite clear enough to myself to enable me to put it in black and white for the benefit of others. Would chemists, whom I have helped in days of yore, say how it is that tobacco smoke affects the leaves of plants so differently when they are wet and when they are dry?

3, Tobacco smoke and all combinations of tobacco should come against the leaves cool. The different fumigators that work with a wheel, patented or otherwise, are very useful in this respect. To be used against plants I would recommend them to our amateur friends, just as I would use them myself; but they are of little use in the hands of common labourers, who soon make all such instruments worthless, and then, if we do not do the work ourselves, we see the folly of investing in an instrument of from 10s. 6d. to 15s. that will so soon be unworkable. For common purposes I use a metal pot, or a common garden pot. Our consumption of tobacco is very small. I know smaller places where more pounds are spent for tobacco than we spend shillings. I am more anxious to keep insects away than to destroy them when they come. For more than one reason, though I think good shag tobacco the best, yet I generally use a little tobacco paper, and of all I have met with as yet, that manufactured by Griffiths & Avis, and sent out at 2s. per pound, I have found the safest and most effectual. The efficacy and safety will greatly depend in every case on the coolness of the smoke. If we use a pot, we therefore cover it with damp moss, and keep it as far from the leaves as possible. Besides presenting the smoke cool, it is always safest to give two or more moderate smokings instead of one heavy one.

The more slowly the tobacco or its preparations are burned the more effectual the smoke will be. I have seen half a shovelful of red fuel used to light a pot of such smoking material. It is best in every way to use one red cinder or a piece of ignited charcoal, put just a little very dry straw, or slips of paper over it, and when burning add the tobacco, &c., and cover first lightly and then more heavily. Where moss is not to be had, a little short grass or damped litter answers equally well. If a garden pot is used, enough of air to support slow combustion will be obtained by the hole in the bottom, if the pot be elevated to leave the hole clear. My dislike to tobacco is chiefly owing to being obliged in my young days to have a hole in the sides of such pots, and then to blow away with a

bellows in a house until it was full of smoke. There is not the least necessity for such barbarism, if a little care and precaution are used. When a fumigator is used, its pipe may pass through a hole whilst the operator remains outside. In all cases where a proper fumigator is used, and the possessor of a little garden is his own operator, nothing is better or even more economical than good shag tobacco. The instrument insures that the smoke, when it reaches the plants, shall be cool.

Lastly, for the present. If you wish one or two smokings to be effectual, smoke as soon as you see the first insect. If you wait until the larger leaves are covered with them, one smoking and syringing will be of no use. In fact, if the bulk of the leaves are so infested, except as an experiment, it is next to labour and money thrown away to smoke at all. The cheapest remedy would be to clear all out and commence afresh. Leaves thus infested with insects seldom recover the combined effects of the insects and the smoking. If only a few leaves are very bad, even if they suffer, the younger ones will come all right. But whenever leaves are much infested, several smokings at intervals of twenty-four and forty-eight hours will be necessary. On every such leaf there will be found several generations of insects, and the younger will escape what will destroy the older ones. Besides the myriads coming into life at once—that is, viviparous, there are myriads of eggs that the heat is continually hatching, and on these, until fairly established in existence, the smoke has no effect. Hence, late smoking, so as to give the insects the chance to propagate freely, involves the trouble of many smokings to get rid of them, as what destroys the older will leave the younger insects and the eggs untouched.

Washing with soap water is more effectual after smoking than washing alone. Reference has lately been made to the strength. It is less effectual in frames and shallow pits than in houses or places where the plants are fastened to a trellis, so that the under sides of the leaves can be freely washed. The insects must have firm hold before they appear on the upper sides of the leaves. Washing is effectual in proportion as the under sides are freely reached. At the strength spoken of by Mr. Robson, not only would the insects be killed and dislodged, but the eggs that were not dislodged would to a great extent be sealed-up from the action of air, and if so, the insects would never chip the shell. The wash is best applied the day after smoking. If the day, after smoking the previous evening, should be dull, or the glass shaded, and little or no air given, I would defer the washing to the second morning. Where this cannot be well done, I would syringe the following morning or afternoon. I am thus precise because the correspondents who have made the inquiry are only a few of many who say tobacco smoke and soap-water washing are powerless against the green fly. I am certain that both will kill, but they will not kill where there is not active life. The powers of reproduction in these insects, by eggs, &c., is wonderful. Never could there be a better exemplification of the old proverb, "A stitch in time saves nine." Put off one early smoking and you may have to smoke many times to get rid of the enemy, as fresh myriads come into existence between the smokings, which have no injurious effect on the eggs deposited. The washings are more injurious to them.—R. FISHER.

SPECIMENS IN BOXES BY POST.

I AM constantly noticing in your columns complaints made by yourself and various correspondents that articles sent in a box through the post are rendered useless, or completely destroyed, by the Post-office stampers. I send you by this post a small cardboard box tied round with string, to which a parchment direction label is attached, and upon which label the address is written and postage stamps affixed. If this system were generally adopted in forwarding articles through the post, I have no doubt, from my experience, that they would invariably reach their destination intact.—J. WALDEN.

[Our correspondent is quite right. If the direction and stamps are on a parchment label tied to the box, the Post-office stampers punch the label, and not the box. This box from our correspondent was quite uninjured.—EDS.]

COTTON SEED A PAPER-MAKER'S FIBRE.—A Lancashire paper maker has succeeded in turning to profitable account particular kinds of Cotton seed as a material for the manufacture of the best kinds of paper. The seed is to be obtained in quantities

large enough to supply the wants of all the paper-mills in the country; and it produces a fibre of the finest quality, at a price that will bring it into lively competition with Esparto Grass. Of all the substances hitherto suggested as a substitute for rags, the best practical judges regard this as the most desirable. One important feature in its use is that it necessitates little alteration in the ordinary machinery of paper-mills, while it will in a great measure overcome the difficulty of our river pollution caused by Esparto.—(Bookseller.)

STRAWBERRIES NOT FRUITING.

In reference to the article at pages 7 and 8 of the Journal of July 7th, and the invitation of "R. F.," the author, to others to give their experience, I can attest and endorse his observations throughout. After many failures and close attention I arrived at exactly "R. F.'s" conclusions. It is nonsense to buy or plant the runners of any variety of Strawberry indiscriminately if fruit is expected. The runners, to make fertile plants, must be the progeny of fertile and bearing stools or parents.

My practice is to plant thinly, never nearer than 12 or 15 inches asunder, unless for drawing and thinning-out in the spring to that distance, as some plants will necessarily fail during winter; but ultimately I allow only one plant to every 12 or 15 inches square. Always in the blooming season, May and June, I root out any sterile plant I find, lest a barren stool should go unobserved and produce barren runners. Thus I am sure in the planting season, early in August, in taking runners, to have them off fertile stools. I plant in strong brown soil, trenched and manured as Potato land, and top-dress any standing beds every autumn with rotten litter, after having cleared off runners and weeds, just as with meadow land. I renovate my beds by trenching and planting runners about every third or fourth year, just as I fancy the stools are exhausted or scrubby.

This treatment brings fair crops, though seasons vary—as spring and summer are mild, showery, and bright with sun, or chill, dry, and dull; and varieties differ too, though suitable sorts are by patience ascertained and alone grown. That, every Strawberry-grower must find out as he may be located—north, south, east, or west.—READER.

IRIS GERMANICA AND THE ENGLISH AND SPANISH IRISES.

In No. 483 I see a notice of English and Spanish Irises which were sent you by Messrs. Barr & Sugden. I purchased a number of varieties of the English Iris of the same firm last autumn, which are now in full bloom, and very beautiful they are and much admired, but, although fine, I think they are surpassed by Iris germanica. I have a collection of these, numbering in all about eighty or ninety varieties, and nothing could be more lovely than they were during the month of May. I consider this a neglected flower in one sense, for go where you will you seldom find it grown, or, if at all, not to any extent, and why I cannot tell, as for elegance of form and brilliancy of colour there is, in my opinion, nothing to excel it at the time of year that it is in flower, and when done flowering, its sword-like leaves make a telling variety of form in the mixed border. I was very pleased to see a dozen or so of flowers of excellent colours exhibited at one of the May shows at the Crystal Palace, and still more pleased to see that they attracted much and deserved attention. Let my brother amateurs get a few, and I feel certain that after blooming them one season they will try and enlarge their collection, not only of them—the Iris germanica, but the English, Spanish, and the many other hardy sorts.—HARRISON WEIR, *Weirleigh, Kent.*

THE PRODUCTION OF OZONE.—We have heard so much of late years about the beneficial influence exerted by the presence of ozone in the atmosphere, that even nonscientific readers may like to know how it can be artificially produced. Hitherto, electricity, phosphorus, and permanganate of potash have been the recognised sources of production, but Professor Mantegazza has discovered that it is developed by certain odorous flowers in a still greater amount. A writer in *Nature* states that most of the strong-smelling vegetable essences, such as Mint, Cloves, Lavender, Lemon, and Cherry Laurel, develop a very large quantity of ozone, when in contact with atmospheric oxygen in light. Flowers destitute of perfume do not develop

it, and generally the amount of ozone seems to be in proportion to the strength of the perfume emanated. Professor Mantegazza recommends that, in marshy districts and in places infested with noxious exhalations, strong-smelling flowers should be planted around the houses, in order that the ozone emitted from them may exert its powerful oxidising influence. So pleasant a plan for making a malarious district salubrious only requires to be known to be put in practice.

PLANTS FLOWERING IN JUNE.

- | | |
|--|---|
| <p>June 2. <i>Mimulus cupreus</i>
 <i>luteus</i>
 <i>maculosus</i>
 <i>moschatus</i>
 <i>cardinalis</i>
 <i>Oxalis corniculata rubra</i>
 <i>Chelone barbata coccinea</i>
 <i>Achillea aegyptiaca</i>
 <i>aurea</i>
 <i>Parnassia</i>
 <i>serrata fl. pl.</i>
 <i>tomentosa</i>
 <i>Lithospermum frutescens</i>
 <i>Dianthus Caryophyllus</i>
 <i>caesus</i>
 <i>deltoides</i>
 <i>barbatus</i>
 <i>Marie Parv.</i>
 <i>Hedderwigii</i>
 <i>fimbriata</i>
 <i>Aconitum Napellus</i>
 <i>versicolor</i>
 " 5. <i>Catananche carulea</i>
 <i>Linum perenne</i>
 <i>Lewisii</i>
 <i>narbonense</i>
 <i>alpinum</i>
 <i>Centranthus ruber</i>
 <i>Myosotis alpestris</i>
 <i>palustris</i>
 <i>sylvatica</i>
 <i>Agathaea caelestis</i>
 <i>Clematis integrifolia</i>
 <i>Aster spicata</i>
 <i>Camassia esculenta</i>
 <i>Campanula grandis</i>
 <i>latifolia</i>
 <i>glomerata</i>
 <i>carpatia</i>
 <i>garganica</i>
 <i>montana</i>
 <i>nitida</i>
 <i>persicifolia</i>
 <i>coronata alba</i>
 <i>Hedychium coronarium</i>
 <i>Lathyrus grandiflorus</i>
 <i>Nepeta violacea</i>
 <i>Lilium caudatum</i>
 <i>chalcidonicum</i>
 <i>Martagon</i>
 <i>tacinum</i>
 <i>Oenothera pumila</i>
 <i>Fraseri</i>
 <i>Lycnis coronaria</i>
 <i>Heracleum giganteum</i>
 <i>Lupinus albus</i>
 <i>polyphagus</i>
 " 9. <i>Helianthemum vulgare</i>
 <i>Linaria cymbalaria</i>
 <i>Orchis foliosa</i>
 <i>maculata</i>
 <i>pyramidalis</i>
 <i>ustulata</i>
 <i>Pentstemon glabrum</i>
 <i>ovatum</i>
 <i>Scouleri</i>
 <i>procerum</i>
 <i>venustum</i>
 <i>gentianoides</i>
 <i>Phloxis Russelliana</i>
 <i>Hemerocallis fulva</i>
 <i>graminea</i>
 <i>Convallaria bifolia</i>
 <i>Anthericum Lilium</i>
 <i>Hieracium aurantiacum</i>
 <i>Pilosella</i>
 <i>Inula glandulosa</i>
 <i>Polemonium aculeatum</i>
 <i>grandiflorum</i>
 <i>Richardsoni</i>
 " 13. <i>Physalis Alkekengi</i>
 <i>Saxifraga Cotyledon</i>
 <i>Geum</i>
 <i>pyramidalis</i>
 <i>rosularis</i>
 <i>Stenactis speciosa</i></p> | <p>June 13. <i>Veronica frutescens</i>
 <i>gentianoides variegata</i>
 <i>incana glauca</i>
 <i>multifida</i>
 <i>Thymus vulgaris</i>
 <i>laevigatus</i>
 <i>Serpyllum album</i>
 <i>Alchemilla alpina</i>
 <i>Crucianella stylosa</i>
 <i>Tritoma Uvaria</i>
 <i>Trollius americanus</i>
 <i>Allium Moly</i>
 <i>Iris variegatus</i>
 " 16. <i>Epilobium angustifolium</i>
 <i>Corydalis glauca</i>
 <i>Delphinium Barlowii</i>
 <i>formosum</i>
 <i>Hendersoni</i>
 <i>Alyssum maritimum</i>
 <i>Eusonia Hypogloussum</i>
 <i>Geuta sagittalis</i>
 <i>tinctoria</i>
 <i>Ajuga reptans</i>
 " 20. <i>Spiraea Filipendula</i>
 <i>japonica</i>
 <i>speciosa</i>
 <i>Aquilegia vulgaris</i>
 <i>Skinneri</i>
 <i>glandulosa</i>
 <i>Alyssum saxatile</i>
 <i>Ruta graveolens</i>
 <i>Trifolium carulea</i>
 <i>virginica</i>
 <i>Fritonea Vularii</i>
 <i>Helianthemum vulgare</i>
 <i>Aster alpinus</i>
 <i>Sagina procumbens</i>
 <i>Sedum grandiflorum</i>
 <i>kautschaticum</i>
 <i>monostromum</i>
 <i>meibotum</i>
 <i>reflexum</i>
 " 22. <i>Erius alpinus</i>
 <i>Sempervivum montanum</i>
 <i>tectorum</i>
 <i>Solidago cambrica</i>
 <i>Campanula Medium</i>
 <i>Trachelium</i>
 <i>Mentha trifoliata</i>
 <i>Aubrieta greca</i>
 <i>Mooreana</i>
 " 25. <i>Sedum acre aizoidesum</i>
 <i>dasyphyllum</i>
 <i>Forsterianum</i>
 <i>glaucom</i>
 <i>Ligustrum vulgare</i>
 <i>Hex Aquifolium</i>
 <i>Salvia bicolor</i>
 <i>Viola tricolor</i>
 <i>cornuta i</i>
 <i>lutea</i>
 <i>Lycnis Githago</i>
 " 7. <i>Schizanthus coccinea</i>
 <i>Hesperis matronalis</i>
 <i>Stachys lanata</i>
 <i>Sanibucus nigra</i>
 <i>Aechusa italica</i>
 <i>Convolvulus mauritanicus</i>
 <i>Potentilla atrosanguinea</i>
 <i>Hopwoodiana</i>
 <i>sulphurea</i>
 <i>Geum coccineum</i>
 <i>montanum</i>
 " 30. <i>Campanula pulla</i>
 <i>Hottotia palustris</i>
 <i>Oenothera Sellowii</i>
 <i>macrocarpa</i>
 <i>Verbascum phloricum</i>
 <i>Lycnis Haageana</i>
 <i>Antirrhinum majus</i>
 <i>Beris Tenoreana</i>
 <i>Polygala Chamaebuxus</i>
 <i>Gypsophila elegans</i>
 <i>Lupinus naus</i></p> |
|--|---|

—M. H., *Acklam Hall, Middlesbrough-on-Tees.*

ARCHIMEDEAN LAWN MOWER.

I HAVE read with interest all that has been said in the Journal about the Archimedean lawn mower; and now I wish to say a few words concerning that machine, having had one in use here all this season.

"D. A.," *Norfolk*, writing in praise of the Archimedean, says, "I approve of the machine for the following reasons:—First, that it will do more work and do it with far greater ease than any other I have seen." I imagine "D. A." has not used many mowers, if he had I am quite sure he would not say the

Archimedean was so easy and so very perfect. Secondly, "D. A." says, "It will cut any length of grass with ease." Now, as I have used it on short and long grass, I say it will not cut it with ease.

I can truthfully say the Archimedean is not to be compared with Green's machine for excellence. It is very inferior to that very excellent machine. An Archimedean that cuts only 14 inches requires two strong men to work it, and it is then hard work, for it must be worked with great speed to get it to cut at all, for if worked slowly it slips over the grass, and leaves it uncut. Again, it quickly gets clogged, through the cut grass working itself through the rollers and getting in between the driving gear. It frequently occurs that I am compelled to stop mowing on purpose to take the machine to pieces to clean it before I can go on mowing, and the smallest stick or stone coming in contact with the cutters leaves a large notch in them; then, of course, it cuts in such places no more. The blades of my machine are notched and look like a saw. It ribs the grass badly, and it does not cut nearly so evenly as Green's or Shanks's machines, while it slips over and leaves uncut such things as Daisy and Clover flowers. Then you cannot cut close to any path or flower bed, or cut verge at all, while you can do so with all the other machines that I know. If there is the smallest breeze it scatters the grass all over the beds and flowers.

In conclusion, I say, putting together the time it takes to clean and grind the Archimedean, and that spent in sweeping the lawn, which you do not want to do with Green's and Shanks's machines, the mowing occupies double the length of time.—*Vitis, Highgate.*

PORTRAITS OF PLANTS, FLOWERS, AND FRUITS.

VANDA CATHARTI (Mr. Cathart's Vanda). *Nat. ord., Orchidaceæ. Linn., Gynandria Monandria.*—"By far the noblest species of the noble genus." Flowers large, yellow ground, barred very numerously with bright brownish red. Native of the Himalayas.—(*Pot. Mag.*, t. 5845.)

DRACÆNA CYLINDRICA (Cylindric-spiked Dracæna). *Nat. ord., Asparaginaceæ. Linn., Hexandria Monogynia.*—Native of the banks of the Old Calabar River, West Africa. Flowers white, bracts brownish purple.—(*Ibid.*, t. 5846.)

IRIS IBERICA (Iberian Iris). *Nat. ord., Iridaceæ. Linn., Triandria Trigynia.*—A gigantic-flowered dwarf. Outer perianth leaves white; inner perianth, yellow ground densely barred with purple, humped bases of stigmas dark purple. Native of the Iberian provinces of the Caucasus.—(*Ibid.*, t. 5847.)

ANTHURUM ORNATUM (White-spathed Anthurium). *Nat. ord., Orontiacæ. Linn., Tetrandria Monogynia.*—Native of Venezuela. Spadix dark purple, dotted with white; spathe large and white.—(*Ibid.*, t. 5848.)

SAXIFRAGA ARETIODES (Aretia-like Saxifrage). *Nat. ord., Saxifragaceæ. Linn., Decandria Digynia.*—Native of rock-crevices in the Pyrenees. It is hardy. Flowers yellow.—(*Ibid.*, t. 5849.)

BRODIAEA COCCINEA.—"A beautiful new hardy bulb imported by Mr. W. Thompson, of Ipswich, from the Trinity Mountains, California, and by whom it was exhibited at South Kensington on the 8th ult., when it received the well-merited reward of a first-class certificate from the Royal Horticultural Society's Floral Committee.

"This *Brodiaea coccinea* produces a flower-scape of from 2 to 3 feet in height, and accompanied by channeled leaves of nearly the same length. The flowers are nodding, and borne in a terminal umbel of from five to twelve, or even fifteen to twenty, when established and vigorous. The flowers themselves are about 1½ inch long, on pedicels nearly an inch in length, and are ventricosely cylindraceous and obscurely ribbed, the tube for about an inch at its base being of a rich magenta-crimson, while the upper part and the six recurved limb segments are externally pea-green, somewhat paler internally. The three exterior petaloid stamens are greenish white, much broader than the perianth segments, and forming a kind of coronet at the mouth of the tube. The three perfect stamens and the trifid stigma are about as long as the perianth.

"As regards its cultivation, we learn from Mr. Thompson that it appears to be perfectly hardy when planted deep enough to be beyond the reach of frost, and, moreover, that when planted in a clump of five or six roots it has a most striking appearance. With him it has hitherto been grown with very good success in loamy soil, but it should be well drained. The

flowering season is May and June. It promises to increase freely, and unlike some of the allied genera, its bulbs do not dwindle, but with ordinary care increase in vigour annually."—(*Florist and Pomologist*, 3 s., iii., 145.)

ENTOMOLOGICAL SOCIETY'S MEETING.

THE last meeting of the present season was held on the 4th inst., the President, Mr. A. R. Wallace, in the chair. The Secretary announced that the second part of the Transactions of the Society for the present year was ready for delivery to members.

Mr. Meek exhibited specimens of Noctuida, *Dianthæcia conspersa* and allied species, from Ireland and the Isle of Man, together with what appeared to be a very remarkable variety of *Glupispia crenata* from the latter locality. The Hon. T. De Grey exhibited *Oxyptilus lactus* from Suffolk; and Mr. Moore a portion of the stem of a creeper, *Coccolus microcarpus*, from Bombay, deformed with a large swelling, within which was a cavity containing three contiguous cases or cocoons enclosing the perfect beetles of a species of the curious thick-legged genus *Sagra*.

Mr. Blackmore exhibited several boxes of insects collected by himself during the past winter and spring in Tangiers, amongst which were a series of specimens of *Anthocharis Eupheno*, and a monstrous specimen of *Pimelia scabrosa* with one of the antennæ bifurcate from the second joint. Mr. J. J. Weir sent some further observations on the relation between the colour and edibility of Moths and their larvæ. Thus the remarkably coloured caterpillars of *Cnecilia Verhasci*, one of the Spark Moths, were not only eaten as soon as their colour was developed, but the perfect moths were eaten. Hairy larvæ were avoided by birds, but other coloured larvæ appeared to enjoy immunity on account of their colour.

The President read an extract from a letter from Borneo detailing instances of protective mimicry in two species of Spiders, one of which closely resembled the dropping of a bird. The Hon. T. De Grey stated that he had observed that the caterpillar of the *Cinxia Fritillaria* not only resembled the leaf of the Narrow-leaved Plantain, on which it feeds, but the chrysalis is just like the seed of the same plant.

Mr. Albert Muller exhibited some imbricated galls on *Ammophila arundinacea* from Aberdeen, made by an unknown insect. Mr. Tegetmeier exhibited some impressions of Lepidopterous insects, made by transferring the scales to paper and colouring the body, and which had been sold as a new species of lithographic printing.

Professor Westwood made some observations on some minute Acari found in the unopened buds of Black Currant trees, with an elongated cylindrical body and only four legs, and another species which forms small pustules on the leaves of Pear trees; these, with a third species which inhabits galls on the leaves of Lime trees, described some years since in France, he regarded as constituting a distinct tribe in the Acaridæ, and for which he proposed the name of *Acarellus*. [The Professor has, however, subsequently ascertained that Du Jardin (not Dejean, as stated by Mr. A. Muller), has formed these insects into the genus *Phytoptus*, regarding them as full-grown animals, whilst a still more recent writer has described them as the larvæ of an 8-legged genus of Mites named *Typhlodromus*.]

The Secretary exhibited the woolly Oak galls of *Cynips Ramuli*, with the Gall-flies bred therefrom, communicated by Sir J. C. Jervoise from Horndean.

Mr. Bates communicated a memoir, being the continuation of his "Enumeration of the Longicorn Beetles of the Amazons, containing the family *Cerambycidae*." There were also read a memoir "On a Collection of Butterflies sent by Mr. Ansell from South-western Africa," by Mr. A. G. Butler; and "A List of the Hymenoptera captured by Mr. J. K. Lord in Egypt and Arabia, with descriptions of the new species," by Mr. F. Walker.

THE AMATEUR GARDENER.

(CHAPTERS NOT IN WALTON.)

No. 3.

RUSTICUS.—See here, *Civis*, these poles and festoons of Ivy have an admirable effect; they are quite a new feature to me in garden decoration.

HORTATOR.—Nothing can be more simple. The poles, you see, are made of Larch wood, with the bark upon them. Before their insertion in the earth they should be partially burnt at the bottom, and have a painting of gas tar to prevent their rotting in the ground. A slender iron chain, which can be purchased at any ironmonger's, is then fastened upon them, letting it hang down in festoons between the poles, which should be about 10 or 12 feet apart. Plant your Ivy against them—prefer strong plants of the Irish—in good rich loam, and supply them during the growing season with plenty of water; if a little quano be added to it twice a-week all the better. The Ivy will then soon run up the poles, and can be trained and tied to the chains.

SYLVA.—Should you be tempted to imitate such an ornament, *Civis*, I would venture to suggest an improvement by

planting some *Wistaria sinensis*, with which even you, townsman as you are, must be well acquainted. I cannot imagine a more elegant, ornamental design than these festoons of Ivy, gracefully interwoven with the *Wistaria's* lovely pendulous racemes of flowers lightly tied-in with the Ivy.

RUSTICUS.—But are you sure of its being hardy? I have never seen it except when growing on a wall.

SYLVIA.—I am quite sure of its hardiness, for I have known it growing as a standard in most exposed situations with perfect immunity. Let me remind you that the success of this ornament depends greatly upon its being placed in an appropriate position.

CIVIS.—But is not the flower of the *Wistaria* very short-lived? I only remember to have seen it for a very brief time in spring.

HORTATOR.—*Sylvia's* idea is an excellent one, and your objection is plausible; but the *Wistaria* does flower to a certain extent a second time in the autumn, and by a judicious thinning-out of the flowers in the spring, and especially by their removal when faded, this second flowering season might be considerably increased and lengthened; but the foliage is in itself very elegant, and its peculiar green would well comport the Ivy.

RUSTICUS.—Permit me to make a suggestion. As the Ivy, even with careful attention, must take some time to run up the poles and cover the chains, might not some of the elegant Clematises, of which there is now such a variety, be used?

HORTATOR.—Undoubtedly, and any of the rapid-growing annual climbers might also be employed. One root of Ivy only need be planted, so that the other side of the pole might be used as suggested.

RICHARD.—Will you permit me to say, gentlemen, how we keep the Ivy so well regulated, and the leaves so fresh and green?

CIVIS.—The very inquiry I was about to make.

RICHARD.—Well, then, I simply take a pair of garden shears in March and cut off nearly every leaf, and as that is the season in which it begins to grow, it only remains bare a very short time, and is quickly again covered with new green leaves, and is not permitted to grow too heavy or cumbersome-looking for the chains.

SYLVIA.—But there is a slight shower of rain; I, at least, must take shelter a moment in this evergreen arbour.

CIVIS.—What music there is in the sound of those rain drops falling so gently on these Laurels, suggesting thoughts of invigorating freshness! But see! what is that thrush about on that gravel walk, thumping his beak so violently upon a stone?

SYLVIA.—As the rain has a little abated, let us approach a little nearer and see. Nay, friend *Civis*, you will not alarm him, birds are so accustomed to be well treated in our garden, that they are not the same timid, shrinking creatures that they are in many.

RUSTICUS.—See, he is breaking the shell of a snail by repeated thumps on the stone, and is preparing a rich feast for his hungry nestlings.

HORTATOR.—And thus relieving us of one of the worst of the many enemies of which gardeners have to complain. I have had to fight many a hard battle with *Richard*, until I appeased his wrath by purchasing some netting to protect the Strawberries; but even now I believe he would gladly extirpate their nests did he not know that such a robbery would involve his dismissal.

CIVIS.—And is the netting expensive?

RUSTICUS.—That is a question which I can answer, having just purchased an ample supply at one penny the square yard, cheap enough you will acknowledge, and readily obtained.

CIVIS.—How beautiful that ray of sun light, now that the shower is over, slants between the branches of that elegant shrub, with its pendulous branches sweeping the lawn with its kirtle of green like a fairy queen on the day of her coronation! What is its name?

HORTATOR.—That is the *Cedrus Deodara*, a native of Nepal, introduced into England in 1822.

RUSTICUS.—And which I believe not many years hence is destined to effect a wonderful change in the English landscape, for I am greatly mistaken if it will not supersede the Larch and Fir, being much better suited to England from its freedom from disease and perfect hardihood, except in very draughty situations.

SYLVIA.—And what an elegant contrast it forms to its brother of Lebanon; the one light, pendulous, and drooping, the other dark, solemn, and majestic.

RUSTICUS.—The rays of the setting sun remind me that it is time that *Civis* and I must say farewell, and thank you for this delicious stroll.—**HORTATOR.**

INSECTS INJURIOUS TO THE PEAR TREE.

No. 4.

ZEUZERA ESCULI, WOOD LEOPARD MOTH. It has been called by entomologists *PHALENA NOCTUA ESCULI*, *P. NOCTUA PYRINA*, *BOMBYX ESCULUS*, *B. PYRINUS*, *PHALENA COSSUS*, *P. BOMBYX ESCULI*, and *COSSUS ESCULI*.

We have just received the following communication:—

"I am sorry to say we are much infested here (Ilford, Essex) with a tree-boring grub. I have just cut out six of these grubs from as many Pear trees in Mr. Thompson's young orchard plantation of pyramids. They also attack the Apple and Quince trees as well as the Pear. In the course of last year I cut out as many as twelve or fourteen from the three sorts of trees mentioned. They usually attack the main stem of the tree, and are, as you are doubtless aware, very destructive, frequently eating away almost the entire substance of the wood, so that a high wind breaks it completely off, perhaps not more than 9 inches or 1 foot from the ground, and sometimes 3 or 4 feet from the bottom.

Mr. Thompson wrote me in 1868 saying that you had promised to pay a visit here to view the young orchard. I trust such visit has not been abandoned, as I think you would be pleased with the trees, of which we have now about 2050, all pyramids, and of which this is the fifth summer. The Apples have hitherto borne but little, but the Pears have done so for several years, and we have this year a very fair crop of *Louise Bonne* of Jersey and *Beurré d'Amanlis* Pears."

The grub enclosed was the caterpillar of the Wood Leopard moth, *Zeuzera esculi*.

From the end of June to the commencement of August, according to the temperature of the season, this moth may be found clinging to trees, especially the Lime. Its specific name, from *Esculus*, a Horse-chestnut, is singularly inapplicable, as it frequents that tree less than any other. It is white, covered with bluish-black spots, as represented in our drawing; the antennæ short, tapering to a fine point. The female is fully twice as large as the male, often measuring nearly 3 inches across the expanded fore-wings. She is also easily distinguished from the male by having her antennæ only woolly at their base, but at the upper part simple; whereas the antennæ of the male are feathered at the base on each side. The thorax is white and woolly, marked by six blue-black spots. She is furnished with a long ovipositor, or egg-depositor, admirably adapted for inserting her eggs in the cracks of the bark of trees, on the wood of which the caterpillar feeds. To the Pear, Apple, Hazel, Walnut, Elm, Lime, and other trees, even the Holly, it is most destructive, burrowing holes into them, destroying their sap vessels, and forming reservoirs for wet to lodge in and promote decay.

The caterpillar is white, tinged with yellow, and spotted with black; its head being horny, with black patches upon it, and on the segment of the body next to it. Its length is about 2 inches when full grown. It is hatched in August, and attains its full size in the June following. It then enters the pupa state, becoming a reddish-brown chrysalis, in a cocoon formed of the dust of the wood which, as a caterpillar, it gnawed down in working its passage. From this cocoon, as already stated, the moth comes forth, either at the end of June or some time between that and the beginning of August.

The chrysalis is of a reddish-brown colour, and has a cylindrical longish body, the abdominal segments with transverse rows of small points directed backwards, by which it is enabled to push itself forward to the outlet when ready to assume its imago or moth form. The head of the chrysalis is armed also with a short hard point, by which it opens a way to escape from the cocoon. Our *fig. 3*, for which, as well as for the other cuts, we are indebted to Professor Westwood's drawing in the "Gardeners' Magazine of Botany," represents a chrysalis case from which the moth has escaped by a slit down the front part of the upper side, and by the head-piece becoming detached.

In making its attacks, the caterpillar generally perforates a hole in the side of a branch, and eats its way upwards in a perpendicular direction, following the course of the pith; but in a case we have seen exhibited by F. J. Graham, Esq., of Cranford, the insect, instead of taking at once a perpendicular course, ate its way all round a branch, keeping just under the

surface of the bark, and devouring the wood to such a depth that the limb was weakened and blown off by the wind. After making its horizontal circuit it then worked its way perpendicularly in the ordinary way.

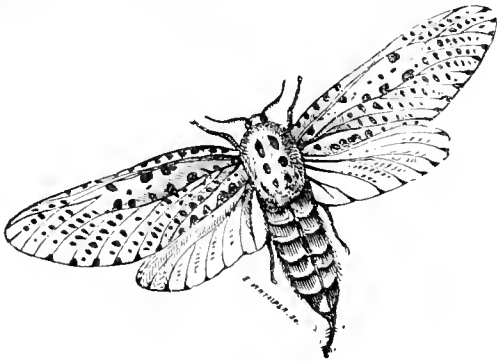

Fig. 1.—The female moth, life-size, with her ovipositor protruded.

The way generally recommended for the destruction of this devastator, is to blow tobacco smoke into the holes. This might do very well in cases where the insect is near the orifice, and the burrow is shallow; but in cases where it extends to the length of 1, 2, or 3 feet, it will be impossible to reach it by this

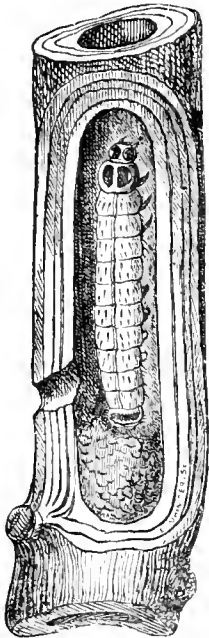

Fig. 2.

Fig. 2.—The caterpillar within the tunnel it works in the tree. The roundish mass beneath the caterpillar is the woody dust it leaves behind, and of which it forms its cocoon.

mode. The only sure course which suggests itself is to wait till the period in June, when the grub has gone into the chrysalis state, and its powers of further destructiveness have ceased, and then to plug up the holes. This will either suffocate it, or it will effectually prevent it from emerging, as in the imago state it is incapable of eating its way out. In this way the reproduction of that individual at least would be prevented. The common house sparrow is a great enemy of this moth.

FORMING A FLOWER GARDEN.—No. 2.

THE DESIGN.

VERY complicated geometrical patterns are, as a rule, to be avoided, for unless the resources of a garden are fully equal to its requirements such designs are rarely to be seen without some flaw in the colouring, or some bed whose ragged appearance tells of a failure in the supply of plants in spring. It is well, therefore, when deciding upon a design, to bear in mind

the means which the gardens afford of filling the beds satisfactorily. A few well-filled beds are far preferable to the most elegant design to which the gardener is unable to do full justice from insufficient means. Moreover, the design of a flower garden should be strictly in keeping with its surroundings; for instance, a terrace garden with its formal accessories should certainly be severely geometrical, while in a shrubbery garden a somewhat more irregular style might be adopted with advantage. As a fair example of this style I give the plan of the flower garden at Egerton House. It is about half an acre in extent, and is in the centre of the shrubbery. The centre of the garden is traversed by a wide walk leading from the house to the bottom of the pleasure grounds, and when the garden was made, a circular space 60 yards in diameter was allowed, but the walk was to be retained, as well as the two large Oaks, one on each side of it, so that a suitable design had to be worked out in such a manner that the shade of the Oaks might be avoided as much as possible. In practice I have found the accompanying plan answer very well; and it is worthy of note here that the plants in the large circular beds 17 and 42 are invariably of the kinds known as fine-foliaged plants. A line of *Christine Pelargonium* between the inner band of *Gnaphalium* and the *Farfugium* has been tried, but was not very successful. From my experience of these beds, I would never depend on anything but fine-foliaged plants in beds at all shaded by trees.

Another important point is the maintenance of a sufficient proportion of turf among the beds, which should not be crowded, but should have a sufficient breadth of nature's green around them to afford an agreeable relief, whereby the brilliancy of their colours will be much enhanced. To no style does this principle more forcibly apply than to those large single beds from 50 to 100 feet in diameter which are occasionally to be met with; such beds are a flower garden in themselves, and when skilfully managed are very beautiful, but to be effective they require a wide expanse of turf around them; for if large beds, like these, are placed in a confined position, surrounded by shrubs or narrow walks, they are far more likely to strike the eye as huge blotches than as masses of floral beauty.

With regard to the shape of flower beds, sharp angular forms are to be avoided as far as practicable, as they are difficult to fill well, and their hard abrupt outlines stand out boldly and uncompromisingly. Very different from this is the soft flow of a scroll partaking of the character of Hogarth's line of beauty, or the graceful sweep of a circle, pleasant to look upon from whatever side it is viewed. Scroll patterns, however, though very beautiful, must be adopted with caution, as in most instances, to do full justice to their graceful outlines, more space is required than for any other style; for if the curves of the scrolls approach each other so closely as to leave but little space for turf or gravel, the colouring is apt to appear crowded and confused.

THE PLANTS.

In a selection of the most suitable plants for flower beds, many kinds grown entirely for the beauty of their foliage justly claim a leading position, and from their undoubted excellence and great utility we gladly accept and welcome them as almost indispensable aids in enabling us to carry out our designs. Their excellencies are many. They offer to the artist many shades of colour not to be obtained from blossom; some soft and subdued charming neutral tints which are most useful to tone down or divide the glowing brightness of their more showy neighbours; while others, by their bright and gorgeous colouring, not only rival the gayest flowers, but owing to their greater stability and immunity from many of those evils to which the blooms from their frailty are liable, not unfrequently take the place of flowering plants, and in some gardens to a much greater extent than I like to see; for, after all, the blossoms of flowers possess a soft and refined beauty unapproached by foliage, and therefore the more flowering plants we can introduce with safety the more general will be the appreciation of the entire design.

GREY-LEAVED PLANTS.—To our old friend *Cerastium tomentosum* must be awarded the leading position as the best dwarf plant of its colour for an edging or front row. When well managed nothing can surpass it, as it makes a dense growth, yet is prevented by its multitudinous leaves and shoots from appearing at all heavy, and it becomes a neat compact mass of pearly grey, which is most effective next to turf. *Cerastium* should always be transplanted once a year; it strikes root freely from cuttings in the open air in spring and autumn, and such young plants are best, as they quickly meet if planted an inch or two apart, but if old plants are retained

they should be lifted early in March, and the soil either renewed, or renovated with leaf mould or rotten dung. Planted in his, the old plants grow throughout the summer with renewed vigour; but if this is not done, and they are kept in the soil for two successive seasons, they suffer very much from

the heat during the second summer, and brown leaves and a starved appearance are the results.

Cerastium Biebersteini I do not like so well, though it is useful for an edging to large beds or bold masses of foliage; but even for such a purpose it is surpassed in the opinion of

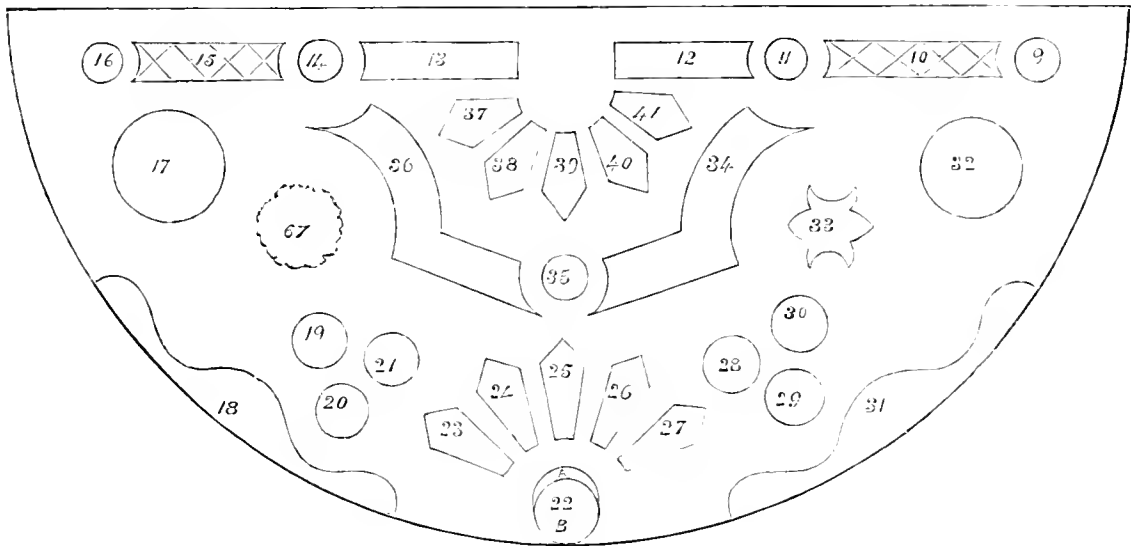
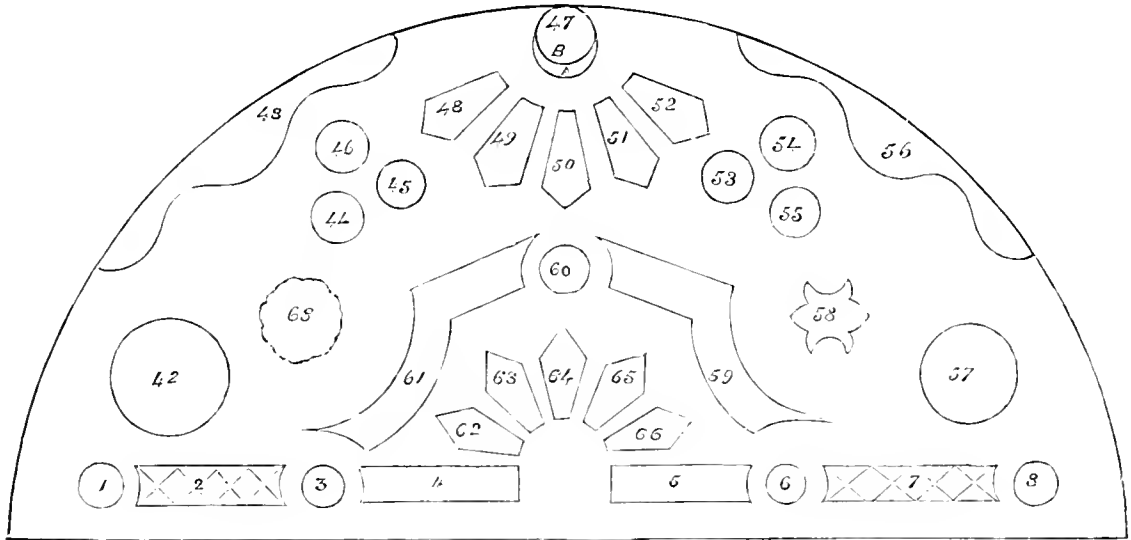

FLOWER GARDEN AT EGERTON HOUSE.

1, 16, 8, 9. *Haliotrope Beauty of the Boudoir*.
 2, 15, 7, 10. The diamonds are marked out with *Vinca major elegantissima*. Inside the *Vinca* in the diamonds is a row of *Iresine Herbertii*, and the centre of each diamond is filled with *Pelargonium Crystal Palace Gem*. The four central half-diamonds contain *Lobelia speciosa*, and the remaining three at each end are filled with *Pelargonium Adonis* or *Little David*.
 3, 14, 60, 6, 11, 35. *Cerastium tomentosum* next the turf, *Pelargonium Christine* in the centre.
 4, 5, 12, 13. A row of *Centaurea ragusina* down the centre, a row of *Coleus Verschaffelti* on each side of the *Centaurea*, with a row of *Lobelia speciosa* outside of both rows of the *Coleus*, making five rows in all.
 34, 36, 53, 61. Three rows of *Pelargonium Mrs. Pollock*, forming a broad band along the centre of each bed, with *Lobelia speciosa* on each side.
 33. *Pelargonium Stella*. 64. *Pelargonium Cybister*.
 37, 41, 62, 66. *Pelargonium Minimum Nesegay*.
 38, 40, 63, 65. *Pelargonium Flower of Spring* (silver variegated).
 17, 42. These beds are shaded very much by the large Oak trees, 67 and 68, they are therefore always filled with fine-folliaged plants in the following way.—A broad band of *Gnaphalium laetum* next the turf, next this is an equally broad band of *Iresine Herbertii*, then comes a narrow band of *Gnaphalium laetum* surrounding the central mass of *Farfugium grande*.

33, 58. Mixed *Verbenas*.
 32, 57. These beds have a large mass of *Gladiolus Breuchleyensis* in the centre, surrounded by a row of variegated *Ageratum*; next this is a row of *Coleus Verschaffelti*, with a row of *Pelargonium Mrs. Pollock* next the turf.
 22, 47. In these beds is a broad band of *Pelargonium Golden Chain* at A, not taken all round, but narrowing off, as shown in the plan, and the remainder of the beds, B, contains a bold mass of scarlet *Lobelia*.
 25, 50. Silver-variegated *Pelargonium Perfection*.
 24, 26, 43, 51. *Verbena Purple King*.
 23, 27, 48, 52. Variegated *Pelargonium Manglesii*.
 29, 54. *Calceolaria Aurea Floribunda*.
 20, 46. *Calceolaria Prince of Orange*.
 19. *Pelargonium Amy Hogg*. 21. *Waltham Seedling Pelargonium*.
 28. *Pelargonium Rebecca*. 31. *Pelargonium Provost*.
 59. *Pelargonium Black Dwarf*. 55. *Pelargonium Lady Constance Grosvenor*.
 44. *Pelargonium Sir J. Paxton*. 45. *Pelargonium Le Grand*.
 The side beds 18, 31, 43, 56 have three rows in front, the first of *Centaurea ragusina*, the second *Perilla*, and the third either a yellow or orange *Calceolaria*. These three rows stretch from end to end of the beds, just filling the narrow parts, and in the remaining spaces are grouped scarlet and crimson varieties of *Pelargoniums*.

many by *Gnaphalium lanatum*, a strong-growing but most useful plant, as, owing to the trailing recumbent character of its long flexible growth, by close attention to pinching and pegging it becomes one of our neatest bedders. Its handsome foliage, of a peculiar soft grey tint, is very telling next deep crimson or pink. One other grey-leaved plant, *Centaurea ragusina*, will complete my selection. It is the best plant of its class for a central, or third or fourth row. It is quite hardy, but as neat young plants are altogether preferable for bedding purposes, an annual supply must either be raised from cuttings or seed. By making cuttings as early in July as possible, and keeping them in a moderate even temperature, they will strike root as freely as a *Pelargonium*. If the stock is obtained from seed it must be sown in January, as the seedlings are very green at first, and require a considerable time before they equal in appearance plants raised from cuttings. For my own part, I very much prefer cuttings, for when once well rooted they may be wintered with the greatest ease in a dry cold pit. Cuttings of this plant also root in a brisk moist heat in spring.

I have selected these plants as being decidedly the best of all in their section; they are of the highest excellence, their merits having been thoroughly tried and their stability proved in a variety of seasons.

CRIMSON-LEAVED PLANTS I shall take next. *Coleus Verschaffelti* worthily comes first, for now the excitement caused by the much-vaunted splendour of its descendants has subsided, our old favourite remains master of the field, the splendour of its rich-coloured foliage never having been approached, much less equalled by any of them. And here I would observe, that my experience of this class of plants leads me to the conclusion, that no fine-foliated plant possessing maculated leaves is ever so useful as those of a rich self-colour for bedding purposes. I have tried most of the new varieties of *Coleus*, and find that while *Verschaffelti* is undoubtedly the best for forming rich masses, or as lines in a ribbon border, yet nearly all the newer kinds are useful if grown in pots, trained in a conical shape 2 or 3 feet high, and then turned out into beds to form mixed groups, or as a background for brighter colours.

Of the *Iresines*, *acuminata* has fine, broad, handsome foliage, and will very likely supersede *Herbstii*, but of this I am by no means certain, as *Herbstii* is a fine plant when grown in a deep, rich, cool soil. It is most effective when next foliage of a similar character, such as that of *Vinca major elegantissima*, or *Gnaphalium lanatum*. Of *Lindeni* I must not yet venture to offer an opinion; if its very elegant foliage only prove bright enough in colour it is likely to be a great acquisition. *Anarranthis melancholicus ruber* grown in a warm, sheltered situation, and pegged closely, makes a fine crimson mass, and is very telling next bright yellow. *Perilla nankinensis* with its rich, dark, chocolate leaves, often changing to a fine bronze in autumn, is a first-class bedding plant; its young stems are very flexible, so that it may either be pegged closely and kept pinched to form a dwarf edging, or it may be had of any height up to a foot.

GOLD AND SILVER VARIEGATED PLANTS.—Among these we have in the very elegant *Arabis lucida variegata* a perfect gem, not more than 2 or 3 inches high, and quite hardy. *Arabis alpina variegata* is also useful. It is a stronger grower than the former. Cuttings made in October and wintered in a cold pit, make useful plants for the following summer. Next these comes *Polemonium caruleum variegatum*, a beautiful silvery-variegated hardy plant, with elegant Fern-like foliage. This is one of the most useful plants in its section; it is best propagated by division of the crowns in spring, and in order to increase the stock quickly the plants should be potted in autumn, and wintered in a cold pit. Another useful plant is *Koniga variegata*. I have frequently used this between plants of *Lady Plymouth Pelargonium*; it grows quickly and has the appearance of a fringe of lace around the *Pelargoniums*, and is easily cut away as the *Pelargoniums* make growth. *Vinca major elegantissima* is a valuable bedding plant, which by judicious pinching and pegging becomes a sheet of pale yellow a few inches high. It requires constant attention, as it grows quickly, but it well repays one for all the care bestowed upon it. *Chrysanthemum Sensation* and *Ageratum variegatum* are alike useful; both are easily propagated, and both bear pegging and pinching well. The Variegated Japanese Honeysuckle (*Lonicera aureo-reticulata*) also makes an elegant bedding plant, if propagated in spring, potted singly in 3-inch pots, and kept in heat and with the growth constantly pinched, so as to form the plants into neat, compact, little bushes. These do

admirably for a line in a ribbon border, but they require constant pinching throughout the summer. All plants of this kind possessing a long trailing habit should never be suffered to produce long shoots when planted in flower beds, but should, by pinching-off the tips of the young growth, be brought as near to the appearance of a regular bedding plant as possible.

MISCELLANEOUS PLANTS.—Of these, *Heliotrope Beauty of the Boudoir*, with its very dark foliage and abundance of grey flowers, forms charming neutral beds. To have this in bloom early, the plants must be propagated the previous autumn and wintered singly in thumb pots. Spring-struck plants are frequently as large when planted in the beds, but they are much later in coming into flower.

The tall *Scarlet Lobelia* are good in groups, or for back rows in ribbon borders; they do not open their flowers, it is true, till late in the season, but their dark stems and foliage are very effective, and when the spikes of deep rich scarlet flowers do expand, nothing can be finer, and yet how seldom are they seen. Their culture is most simple; pack the old stools closely in pans or boxes in autumn, winter in a cold pit, avoiding much damp, and early in March divide the old plants, potting the offsets singly in small pots. These, placed in any position under glass where they can have abundance of light and air, as in a pit, frame, or cool house, become nice plants by May. Care must be taken to guard them from the ravages of snails, which are very fond of the young succulent shoots.

Another useful member of this family, of more lowly growth, is *Lobelia speciosa*. Coming early into bloom, and continuing in great beauty throughout summer, it forms a dense even mass of deep blue, and is everywhere welcomed and admired. It may be useful to some if I advert to two or three different methods of culture. The simplest way of all to obtain a stock is to sow a bed on a warm border early in September. The young seedlings are protected in winter with a frame having glass lights, which are covered with mats and litter in hard frosts; the plants are slightly thinned, but nothing more is done till they are taken up with a trowel and planted in the flower beds in May. This plan answers very well for gardens in which an early display is not required, otherwise the usual plan of sowing seed in pans placed in heat in March is preferable. In gardens having very poor soil, where strong plants are required, I know no better way than to place a glazed frame on a mild hotbed, fill it to within 3 inches of the glass with light, rich, sandy soil, settle this gently down with the back of a spade, and prick out the young seedlings 2 inches apart. Wash the glass lights with a thin mixture of lime and water for shading, sprinkle the plants twice a day with warm water, and give a thorough watering when necessary, and a little air on hot days. When the plants are growing freely, more and more air may be given, till the lights are drawn entirely off, care being taken that the tender foliage is not scorched by the sun. Seedlings so treated grow with amazing rapidity, and some care has to be exercised that the plants do not become too robust, and so, when removed to the flower beds, continue to grow too strongly.

The method I prefer to all others is to select a dozen or two of plants from a late batch of seedlings or cuttings, to pot them singly in 3-inch pots, and plunge them in the open garden till the end of August, when they are taken up and shifted into 5-inch pots, and then plunged to the rim in coal ashes till October; they are then taken into the houses along with the other bedding stock. In the following February they are furnished with a good crop of cuttings, and the required quantity of young plants is raised with the greatest ease. By shifting the stock plants in the end of August, ample time is afforded for them to become thoroughly established in the 5-inch pots before they are housed. I lay some stress on this, because *Lobelias* shifted late in autumn are very liable to damp off.

Viola cornuta is another very useful summer plant of most easy culture. In order to insure a lasting summer display, cuttings must be taken in March, and the young plants planted in the flower beds in a deep rich soil at the same time as the other bedding plants. It grows freely, and soon becomes a mass of bloom of a peculiarly fresh and pleasing appearance.

This selection of plants may be thought a small one, but if to these are added the splendid varieties of bedding *Pelargoniums* now in cultivation, together with *Verbenas* and *Calceolarias*, ample materials of all shades of colour may be had in sufficient variety to fill a design, however large, in the most satisfactory manner. Of the relative merits of *Pelargoniums*, *Verbenas*, and *Calceolarias* I shall say nothing, as they have been fully treated of in former papers, but will next proceed to

consider the arrangement of the plants.—EDWARD LUCKHURST, *Egerton House Gardens, Kent.*

NOTES AND GLEANINGS.

THE third Show this year of the ROYAL OXFORDSHIRE HORTICULTURAL SOCIETY, will be held on Tuesday, July 19th, and three following days, in the Observatory grounds, Oxford, by kind permission of the Radcliffe Observer, and the amounts in prizes offered are as follows—viz., for Plants, £35 7s. 6d.; Cut Flowers, £26 3s.; Fruit and Vegetables, £12 12s.; Cottagers' prizes, £36 17s. 6d.; in all £120 10s. The ROYAL HORTICULTURAL SOCIETY will hold their fourth provincial Show at the same time and place, and prizes amounting to nearly £800 will be given away. The band of the Royal Artillery from Woolwich will play daily under the direction of Mr. J. Smythe, as well as the band of the Oxfordshire Militia. The following railway companies have kindly consented to convey plants from the Exhibition free of charge, providing they remain the property of the person who transmitted them to the Exhibition—viz., Great Northern, Great Western, London and North Western, London and South Western, and Midland. The Exhibition will be open on Tuesday, the 19th July, at 2 o'clock P.M., and on the three following days at 10 o'clock A.M. The terms of admission are—for the first day, 3s. 6d. (if purchased on or before Monday, July 18th); on the days of Exhibition, first day, 5s.; second day, 2s. 6d., third and fourth days, 1s. Gardeners can obtain admission as follows—on producing their masters' cards—viz., first day, 2s. 6d.; second day 1s.

— THE FRUIT COMMITTEE of the ROYAL HORTICULTURAL SOCIETY will meet at Oxford on Wednesday next, July 20th, at 11 o'clock A.M., to examine such fruits and vegetables as may be sent for their opinion.

— THE drought has been so great about London, and forage so scarce, that cow-keepers are eagerly purchasing the weeds grown in the Royal Horticultural Society's garden at Chiswick, for cattle food. The weeds are unusually fine, certainly, having been undisturbed for the last year or two; and it is gratifying to see how even its misfortunes can be turned to good account for the Society's benefit.

— THE "German village" trees have again made their appearance in Trafalgar Square, dotted about much in the way children do their mimic toys. Is it solicitude for the beauties of the National Gallery that these terrace trees are not placed on the only public terrace London possesses? or is it that those in authority do not know how to make the best use of the objects they are entrusted with? Last year we suggested that some of these trees should be placed on the terrace above, where they would form an effective line of green in front of the National Gallery; but we presume some arbiter of taste directs the decorative department of the metropolis who knows better.

WORK FOR THE WEEK.

KITCHEN GARDEN.

SEE that in this department weeds are not allowed to seed amongst growing crops, such as Potatoes and Asparagus, where, from the luxuriance that surrounds them, they are apt to elude detection till they have deposited their seeds; attention in proper time to such matters entails not one-tenth of the labour that neglect ultimately does. As soon as caterpillars attack any of the *Cabbage* tribe, give a slight dredging with white hellebore powder in the morning. Make a sowing of East Ham Cabbage for early spring use, and a late sowing of Coleworts. Pay strict attention to early crops of Celery; let them be gone over with the hand, and all offsets taken off, and where practicable let it have a thorough drenching with dung water, after which, on the following day, give a slight earthing-up to prevent evaporation. Plant out succession crops of it. People sometimes complain of their Celery "running;" Celery plants removed in a gross state need little more than drought to bring on the flowering habit. Sow another bed of *Endive* forthwith. Make a small sowing of Early Frame Peas. If the autumn be fine, they may be useful. Make a sowing of White Stone Turnips.

FRUIT GARDEN.

Attend to previous directions in regard to thinning and stopping the young shoots of all trained fruit trees, and now make the final thinning of Peaches and Nectarines, of course leaving the heaviest crop on the most vigorous trees and

strongest branches. As a general rule no two fruit should be left together. Plum of the large kinds, as well as the finer sorts of Peas, should also be thinned if the crop is too heavy. Young Peach and Apricot trees when making over-vigorous leaders should have the points of the branches shortened to encourage them to make other shoots less vigorous, and of a fruitful character, which will obviate the necessity of shortening them back at the winter pruning. Strawberries will require frequent waterings in this dry weather: Place netting over the plants to protect them from birds, and it will also be very beneficial in partially shading the fruit from the midday sun. Layer the runners in 3-inch pots. For this purpose prepare a compost of two parts of friable yellow loam and one part of well-decomposed dung, with the addition of a tenth part of the whole of charred material. Take care that the pots are well drained, and have them placed on a south aspect, and on boards or slates raised a few inches above the surface of the ground, to prevent the worms getting into them. All spare runners may be cut away, and keep the plants free from weeds. Thin and stop shoots of Figs as soon as they have made a growth of about 6 inches; and remove all useless growth from Vines, keep the fruit close to the wall, and shaded by the foliage from the sun.

FLOWER GARDEN.

The Roses are the great attraction here at present, and these should be frequently looked over, removing decaying flowers, &c., which, if allowed to hang on the plants, have a very unsightly appearance. Now is the best season for observing the effect of the arrangement of colours, &c., and if any alteration is deemed necessary it should be carefully noted. This will greatly facilitate its execution at the proper season. Proceed with the propagation of favourite sorts which it may be desirable to increase either by budding or cuttings. The Hybrid Perpetuals, Teas, Chinas, and Bourbons are generally preferred on their own roots, and firm, short-jointed shoots of these root very freely at this season; but to insure success they should be afforded a slight bottom heat, be carefully shaded, and not kept too warm until they emit roots. They will, however, root under a hand-glass on a shady border. Remove suckers from worked plants. Cut-back the shoots of the autumn-flowering varieties to the most promising eye, as soon as all the flowers are expanded and begin to fade. If manure water cannot conveniently be given, stir the surface soil with a fork and apply a good sprinkling of guano, the strength of which will be washed down to the roots, and will serve the same purpose as manure water. Slugs must be sharply looked after, otherwise plants to which they are partial will be very likely to be injured. The propagation of flowers for masses is a most important matter, and much depends on its being performed in due time. If stove plants for the ensuing year are propagated and potted-off too late, they will not be easily preserved during the winter. A bed should be prepared in an open situation where constant attention can be given. The soil should be free and rather sandy, and should be made somewhat fine, as is usual for cuttings, and a canvas screen should be always at hand to ward off continued sunshine. After the bed is made particularly level in order to equalise the moisture by watering or otherwise, a number of striking-glasses should be placed ready to cover the cuttings as they come to hand, for after all it must be progressive work. Choice Verbenas, Calceolarias, Pelargoniums, Petunias, Heliotropes, Fuchsias, Pentstemons, Mule Pinks, Picotees, double Wallflowers, with numerous other mass or border flowers may be successively put in, as cuttings of a proper character can be obtained. They should be slightly watered when put in, and should receive a slight shading in sunshine for the first month, after which they may be gradually inured both to sunshine and air.

GREENHOUSE AND CONSERVATORY.

Follow up shifting with such of the hardwooded tribes as require it. A turfy compost of three parts sandy heath soil of a fibrous and rather lumpy character, and one part sound loam of a similar texture, will suit the majority. The more tender kinds will require lumps of charcoal, stone, or crocks introduced occasionally until near the surface of the pot. Let every attention possible be paid to the most thorough drainage; this cannot be too complete, taking care especially to use very hollow crocks at the bottom, for if these lie too flat and become closed up, it matters little how much depth of drainage material is upon them, all will be stagnation. Some of the stove plants that have recently been brought into the conservatory will require attention to prevent their being injured by damp if cloudy weather should occur, and it will probably be

necessary to use slight fires occasionally for the purpose of drying the atmosphere of the house. The propriety of this will, however, greatly depend upon circumstances, for in small well-ventilated houses damp will hardly be troublesome, whereas in lofty houses with but little ventilation, and the roofs overgrown with climbers, it may be so to a very great extent. But at this season there is nothing to fear from cold, and air should be freely admitted at every favourable opportunity, using every care to keep the atmosphere of the house as dry as possible, and keeping the plants clear of decaying flowers. Considerable care will also be necessary in watering recently repotted specimens, whether of the soft or hard wooded class, as in the case of cloudy weather they will require very little water, and will be speedily injured by a careless supply. Continue to carefully regulate the growth of twiners, but avoid tying them too closely, and allow them to grow according to their natural habits as much as circumstances will permit. Examine the border plants frequently for insects, which, if allowed their own way at this season, soon injure the young tender growth. The *Luculias* are matchless subjects for the conservatory borders and are deserving of every care, but they are very subject to black thrips. Tobacco smoke is the most effectual remedy for this pest.—W. KEANE.

DOINGS OF THE LAST WEEK.

On the evening of this, the 9th inst., we have had thunder, but little rain, though it has fallen heavily in some places in the neighbourhood. In summer, especially, we often notice that the cloud breaks on the height, and sheds its contents in the valleys. In winter, the heights get their share more regularly. However, the showers which we have had, though as yet doing little to fill reservoirs, have refreshed vegetation, and even the lawn, beginning to be brown, is putting on its bright green livery. As a commencement, we are having trough piping placed round our pits, that the water from them, as well as houses, may be conveyed to a clean-water tank. The water from these pits was not lost formerly, as it fell on firm ground, so sloping that the rains ran to cesspools, whence it was conveyed in pipes to a pond concealed from view. We thus from roadways, &c., obtained a quantity of water, but it required to stand some time to become clear. We shall now have more clean water, and will just have so much less in the pond.

Celery.—The cloudy days, helped by occasional drizzles, enabled us to plant out a good deal in beds, generally three rows in a 4-foot bed. As some of our coadjutors say, there is no difficulty in earthing it up by placing light boards between the rows, and moving the boards as the earthing-up proceeds. We have long dispensed with the boards, even when we have had from four to six rows across a bed, and, provided each plant is nicely cleaned at the base, and then loosely tied, the earth can be easily applied without the help of boards. The earth is merely well pulverised and squeezed to the plants a little by the hand. In stiff soils, and where slugs and worms are apt to be troublesome, it is a good plan to have semicircular pieces of old spouting, say 18 inches long, of tin or zinc, made on purpose, two to be placed round and pretty close to each plant, the interior to be filled with ashes, and then the space between with earth, drawing up the pieces of pipe as you go along. This plan is one of the best for preventing slugs and snails marking the *Celery*.

Our *Celery* beds have been filled until now with bedding plants, dwarf Peas, and Potatoes, and now they have had an addition of very rotten dung, made moderately firm before planting. For large *Celery*, rather rank dung may be used. When sweet, crisp *Celery* is desired, all rank dung should be mixed with the soil at the bottom, if used at all, and sweet dung mixed with soil near the surface. On the ridges we have had rows of Peas, but the dry weather has caused some of them to come to maturity earlier than we wished, and as some rows were removed we used branches laid across the bed to give a flickering shade until the air became cooler, and the clouds gave a little more shade. After one good watering at planting, we must be satisfied with a few surface sprinklings. Our plants would not have required the latter if they had been better established with good balls before turning out, as we generally have them; but in the press of matters only part of what is planted received the usual attention, and therefore they feel the moving more at first. Our later crops will be more independent in this respect, and where water is scarce it will ever be easier to water a bed somewhat thickly planted than the same plants spread over a large space. Such plants

forming good balls, with young fibres bristling all round them like a wig, when well watered some hours before lifting, will require comparatively little watering when transferred to sunk beds or trenches.

Cucumbers.—Our earliest, in a pit heated by hot water, have been all that could be desired, but twice they have had a little fly, and what was worse, they were attacked with red spider. The latter was mostly our own fault, as three times successively we put a row of Strawberry plants on a shelf close to the apex, and thus got Strawberries to ripen and colour well some days earlier than we could have ripened them elsewhere. The dryness, so necessary to full flavour, prevented us syringing near the top of the pit—in fact, we could syringe but little, hence the presence of the red spider. These Strawberry pots were taken there merely to hasten the swelling of the fruit, as it was all set and swelling previously. On taking away the Strawberry-shelf we cut off the leaves of the Cucumbers most affected with the spider, and then two or three smokings with tobacco paper and syringings with clear soft-soap water, removed all trace of the insects, and the plants now look as healthy and vigorous as they did at first. We had planted out a few more in case the plants had shown signs of exhaustion.

A few of the details of treatment may be given. The pit is nearly 6 feet wide, with a space shut off inside of about half that width. As we wanted Cucumbers soon after planting out in spring, we considered that width too much. We therefore kept our plants in rather large pots, banked-up all round with sweet hot dung to within an inch of the rims of the pots. When fairly established the bed was surfaced all over so as to be level with, and frequently to cover the rim of the pot, the pot itself being filled with rich compost. Roots now come from the top of the bed and run along the surface of the bed, and a sprinkling of fresh rich compost has been spread over them two or three times. The curbing of the roots by the pots caused the early fruit to swell better, and prevented over-luxuriance, and the pots, though now concealed, do something still to secure fruitfulness and moderate growth in such little space. With elevated span-roofed or lean-to houses with a good length of roof, we should consider such cramping of the roots unnecessary, unless where early results were wanted. We can produce Cucumbers plentifully enough in the usual low pits and frames, but in general, and especially for all large, vigorous-growing kinds, the pit and the frame are poor substitutes for the house with the more elevated roof, and where the most of the work can be done by the operator standing beneath the stems and foliage of the plants. In such circumstances, with even soft-soap water at command, we should give little chance to red spider, thrips, or green fly to do much more than make their appearance.

FRUIT DEPARTMENT.

Here we pass other matters to chronicle a disappointment. A Peach tree on the back wall of our orchard house, beautifully supplied with fruit, and looking pretty well until within a few days, is going to bid us good-bye. Although we knew it had a trial to go through, we did not expect we should lose it. About February or March the stem of the tree had been nibbled all round by mice, every bit of outer and inner bark being removed to the depth, perpendicularly, all round the stem, of from 6 to 7 inches. The alburnum, or last season's layer of wood, was also eaten into in various places, but a good portion seemed to be untouched. We covered over the place with a mixture of clay and cow dung, tying it up securely with a cotton cloth, so as to exclude air, and when examined once or twice we found fresh bark freely forming from the upper and under sides of the large wounded or barked part. As we had often witnessed the heavy crops carried to completion on the branches of fruit trees, where, owing to canker, there were open spaces all round destitute of bark and alburnum, we were in hopes that our tree, and the crop on it for this year, would not have suffered, and more especially as fresh bark was forming on both sides of the wound. We have noticed Plum, Pear, and Apple trees living and fruiting for years with more than double that space of stem destitute of bark. We have been astonished to find, on removing Peach trees becoming exhausted, how very small a space of living wood sufficed to keep up the circulation. We felt annoyed at the mice thus clearing away the bark from the stem of a favourite tree, but after covering the wound over we were in hopes that our tree would eventually suffer no more than it would do from a rather severe ringing. Something there may be in the very nibbling of the mice, as we have often seen hundreds of Laurels die upwards, even though the nibbling did not go

right round the stem. We have not examined nor removed our tree, but we suspect we shall find that the internal wood of the stem is decayed, so that the mice did not leave enough of wood for the sap to pass freely. In other cases we have found that large wounds and openings would be healed over in a year or two, especially when covered up from the sun and air.

ORNAMENTAL DEPARTMENT.

The work was much the same as in the previous week, diversified with much labour in fresh arranging the corridors and conservatory, and in potting plants, pricking off Chinese Primulas, Cinerarias, planting out old Cinerarias to get suckers from them, and sowing the seed of herbaceous and semi-herbaceous Calceolarias blooming for next spring.—R. F.

TRADE CATALOGUE RECEIVED.

James Veitch & Sons, Royal Exotic Nursery, King's Road, Chelsea, S.W.—*Catalogue of New and Beautiful Plants for 1870.*

TO CORRESPONDENTS.

THE JOURNAL OF HORTICULTURE PRIZE (Competitor).—There is no limit as to the number of dishes of fruit for this prize to be awarded at Oxford on the 19th, and flowers may be used in any way in arranging the dishes artistically.

ELM SEEDS (A. McCallum).—The seeds you enclosed were not of the *Ulmus campestris*, English Elm, but of *U. montana*, the Mountain Elm.

ROYAL BOTANIC SOCIETY'S SHOW.—Messrs. Weeks & Co. inform us that they received a first-class certificate of merit for their patent duplex boiler and conservatory designs. If the Society advertised their awards in our columns as the Royal Horticultural Society does it would be satisfactory to the prizetakers, and omissions would not occur.

FRUITING VINES (Reader).—In reference to the Vines alluded to at page 465, if you resolve to fruit the Vines from the sill up the upright glass, then leaving the newly-turned-out plants 6 feet in length was right enough. This plan may be well followed when the house is devoted to Vines only, but when other plants are grown in the centre of the house the light from the front is too much obstructed. You may, as you propose, try more heat and moisture to get the Vines to grow and break, but in our opinion the coolness of the house was rather in favour of the Vines breaking. After the treatment you have given them we are at a loss to account for the buds not breaking. No doubt the check given to the roots would be considerable, but treated as stated the buds ought to have broken.

VINE SHOOTS DYING AT THE TIP (J. M. Skell).—Your Vine shoots perish through scorching, caused by a too hot dry atmosphere, the roots in the meantime being plentifully supplied with moisture and making succulent shoots. Give more air, and keep a moister atmosphere during the day.

DISEASED SHOOTS AND LEAVES OF VINES AND FUCHSIAS (J. R.).—The shoots and leaves were rather far gone to enable us to judge surely; but they had signs of scalding from hot vapour, if these signs were not the result of sweating in your letter. Besides that there were marks of thrips, and we are almost sure of red spider as well. For the latter, sulphur and syringing with soft-soap water would be the simplest remedies, the sulphur being placed on a hot-water pipe or on the wall where the sun shines. If mixed with soft soap it will adhere tolerably well. The soft-soap water should be applied as stated the other week, clear, and of the strength of 1 lb. of soap to about thirty gallons of water. The thrips is a little narrow insect that jumps as you approach it. The best remedy is smoking with tobacco at night when the leaves are all dry, and syringing the next day with soap water. The only remedy you have—of cutting Fuchsias down and getting them to grow afresh in a mild dung heat—is effectual, because the moist heat is bated by red spider and thrips.

HEATING A SMALL GREENHOUSE (A. Downes).—There is no doubt but you may keep up a temperature of from 50° to 60° in your small glass house heated by gas, hot water, and otherwise; but we are doubtful if you can get all this done, except with the lightest materials, for 45. If you refer to our No. 341, pages 273 and 279, you will find all we can state about gas-heating.

DIRTY RAIN WATER (Item).—It would not hurt the roots of plants unless muddy; but it would be easy to make it clear by passing it through a barrel or reservoir with pebbles at the bottom, and rough clean gravel and charcoal above these. A layer altogether from a foot to 18 inches thick would do if frequently cleaned and replaced. The New River water we should use without hesitation or preparation.

MELONS GOING OFF (G. A. N.).—We see nothing wrong with the bottom heat, nor in the time of admitting air and shutting up, only we should like to give a little air before 8 A.M., and not shut up altogether at 4 P.M. We think the gangrene on the shoots arises from condensation of moisture on the glass, and consequent drip on the stems or principal branches; but we have suffered more from the disease this year than during any one of the past twenty years, and lost whole framefuls of plants. We have reverted to a practice now little in vogue, that of growing the plants from cuttings. We have plants propagated in this way with fruit set and swelling in six weeks, and none of the daunting tendencies of their parents. Fruit 17 inches in circumference is a good size, it will weigh 2 lbs. and more, but we have many larger fruit of the same sort (Beechwood), although there are three and four on each plant—perfect spheres, and netted all over. They will weigh 4 lbs., and are larger than we like, but if they net well we shall not care how large they may be, for with good netting there is favour. It is very unusual for Melon seeds to germinate inside the fruit, and especially before it is ripe.

WATERING POT VINES WITH LIQUID MANURE (Item).—The liquid manure should be continued until the Grapes are fully swelled and properly coloured, and then it is well to give clear water; but no more than sufficient to keep the foliage fresh. Fifteen bunches on a Vine in an 11-inch pot are good, indeed more than can be coloured well; and the size—1 lb. each—is also good, but all depends on how they finish. It is

easy to obtain a quantity of bunches, but quite another matter to have them perfect in size, colour, and flavour.

CLEMATIS TREATMENT IN POTS (Subscriber).—The plants when in pots require to have the necessary potting early in spring, or after they have been pruned; all the soil that comes away freely may be removed, but avoid breaking the roots, though the sides of the ball should be loosened, and do not give a large shift but allow a moderate space between the sides of the pot and the ball. A compost of two parts sandy fibrous loam and one part leaf soil or old cow dung, with free drainage, will grow them. They will not need much water until they are growing freely, then copious supplies will be required, especially when they are in flower. When the growth is complete the plants should be kept rather drier, but not much so until the leaves turn yellow, and then the watering should be reduced to a minimum, only a little water being given occasionally when the plants are at rest to keep the wood from shrivelling. Before they begin to grow, or in December or January, they should be pruned, cutting out the old, long, bare shoots, leaving as many of those of the previous year as possible. The summer pruning is simply a matter of stopping any straggling shoots, and training so as to cover the trellis equally in every part, but not too thickly. They should have a light airy position in a cool house, otherwise their flowering is not satisfactory. The form of trellis is immaterial.

BELADONNA LILY CULTURE (Item).—Pot the bulbs now, or as soon as the foliage decays, in a rather strong yellow loam, providing good drainage, and placing from five to seven bulbs in a 6-inch pot. Set the pots in a saucer filled with sand, which at no time should be allowed to become dry. They may stand constantly on a shelf in a greenhouse. No water will be required until they begin to grow, and then the soil should be kept moist, and when growing freely a good supply of water must be given, continuing it until the growth is complete, lessening it with the decay of the leaves, and leaving it off altogether when that is complete, still keeping the sand moist. Do not repot for the next year at least, but the drainage must be kept clear. In the open ground they require to be planted in front of a greenhouse, or in some other warm aspect. The bulbs should be planted about 3 inches deep, and be mulched every autumn with a layer of partially decayed leaves an inch or two deep, protecting the foliage also in very severe weather with mats.

STRAWBERRIES (W. G.).—It is very difficult to name Strawberries unless one sees them growing, and even then the number of sorts has so much increased that there is much uncertainty about them. No. 1 appears to be Vicomtesse Hericart de Thury; 2, Keen's Seedling; 3, is like Myatt's Eliza, well grown. Your fruit of Dr. Hogg, 3 inches in diameter, are very fine. Mr. Radelyff is also excellent.

CUTTING OFF STRAWBERRY LEAVES (H.).—No practice is worse than cutting off Strawberry leaves after the fruit has been gathered. The leaves have to digest the sap, and help to provide for the next year's producing.

FERTILISING CARNATIONS (Tyrol).—With a pinners pluck out the petals and cut out the stamens of the flower you wish to fertilise; secure the pollen from the flower you wish to fertilise with, apply it to the stigma of the flower from which the stamens have been removed, and enclose the flower in a fine gauze bag. A camel-hair pencil is best for removing the pollen and applying it.

MOVING NEWLY-BUDDING ROSES (J. W. C.).—Roses budded now may safely be moved in November next. With regard to the new Roses of the current year, we have no doubt "D. Deal," will give us some particulars in due course.

WINTERING IRESINE AND CANNAS (Item).—The former is best wintered from cuttings put in early in August in light, sandy, poor soil, and when rooted potted-off singly in small pots, and kept rather dry in a house with a temperature of 50°. If well established in pots before winter, the plants are not difficult to keep, except in a low, moist atmosphere, but they must be kept dry. If the foliage remains fresh they have enough of water, and none should be given as long as it remains so, but it must not be allowed to flag. The cuttings may remain in the pots in which they were struck, and be potted off in spring; the chief thing to guard against is damp. Cannas should be taken up in autumn after the first frost, be placed in pots large enough to hold the roots, and in sandy loam, placing them in an airy greenhouse, and keeping them there until the growth is ripened off; then cut them down and put them in a dry place, from which frost is excluded. No water, except a watering after potting, will be required. Return them to the greenhouse in March, but if they can be placed in a gentle hotbed for two or three weeks, so as to give them a start, all the better.

DIFFERENT ROSES ON THE SAME STOCK (Lang).—If one proves to be a Tea Rose, and the other a Hybrid Perpetual, we fear the latter will be too strong for the former. You can let both grow till you prove the kind, and save whichever you think the more valuable to you. Hybrid Perpetuals will do mixed on the same stock, provided care be taken to choose those of similar vigour of growth. We do not think, however, there is much to commend the practice.

MADAME FROISSART ROSE (A. M. Jackson).—We do not know of any Rose called Madame Froissart, neither is there, we believe, a Madame Andre Leroy, a distinct Rose from Andre Leroy, generally called Andre Leroy d'Angers.

CLIMBING ROSES (W. R. J.).—Nearly all the most rapid climbing Roses, as the Ayrshire and Multiflora Roses, &c., are white or bluish. The old Boursault Amadis will, perhaps, cover a wall with red Roses more quickly than any other; but we should not plant Amadis only, but Gloire de Dijon, which is the finest of all climbing Roses. Climbing Devoniansis, and Celine Forestier, likewise General Jacqueminot, and Madame Charles Crapet, which, though they will not grow as high as the last three named, will fill up the lower part of the wall for 7 or 8 feet, allowing Gloire de Dijon and Climbing Devoniansis to cover the upper part, which can be done by judicious training. If the soil is light and dry, put plenty of good farmyard manure and cow dung in the border previous to planting.

ERRATUM.—In my last paper on new Roses, near the bottom of the first column of page 7, "Dear to us by Francois Lacharme," ought to have been by "Charles Lefebvre."—D. Deal.

ENGLISH ELM IN SCOTLAND—ALTERING A TREE'S HABIT (A Subscriber).—The English Elm (*Ulmus campestris*), will grow near Aberdeen. We do not know in what way you will induce trees naturally of weeping habit

to grow upright, but you may make those which are stunted grow more freely by cutting off the strongest of the side branches, thus throwing the main support into the upright-growing shoots. This should be done in winter when the trees are leafless, and if persisted in a few years will give you a greater height of tree, and, of course, length of stem.

GRAPES SPOTTED (*A. M. Callum*).—The "black spot that appears on the side of the berries and causes an indentation," is the spot. It is mostly attributable to a deficiency of foliage, and neglecting to give a proper amount of air, also by the roots being in a cold wet border. There is little doubt of the scorched appearance of the foliage, which is arrested by sulphur, arising from mildew, but we cannot say conclusively without seeing a specimen. It is most likely the small white insect of the same size and appearance as thrips, but in a young state. The white or young thrips do not jump about, but the mature insect does so freely. It may be you have the white aphid, which is the most difficult of all to exterminate. Thrips varies considerably on different subjects.

VINE LEAVES—AERIAL ROOTS (*W. T.*).—Do not remove the leaves; they are absolutely necessary to secure size, colour, and flavour to the Grapes. Aerial roots are not injurious to the Vines, but are evidence that they are vigorous. The roots may be removed and will not appear again so soon, as you can have the air of the viney drier when the Grapes are ripening.

OPENING GARDENS TO THE PUBLIC (*J. Wise*).—You are altogether wrong, and your letter must not be published.

PLANTING STRAWBERRIES (*J. Walker*).—Your old pasture trenched 2 feet deep, and a liberal quantity of manure worked in, ought to grow Strawberries well. Being a very strong clay, the addition of road scrapings will be beneficial. Five varieties for succession—Sir Joseph Paxton, Keens' Seedling, Rivers's Eliza, Dr. Hogg, and Frogmore Late Pine.

MUSHROOMS DECAYING AND MAGGOTTY (*F. K. Betheforth*).—We could make nothing of the Mushroom sent, as it was altogether rotten—top and stalk. As you say that the small ones are the same when they appear through the ground, we come to one of two conclusions: either the surface soil is too light for summer, or the place where the Mushrooms grow is too hot for them. We used to have some trouble with Mushrooms in July and August when we depended upon a lean-to house facing the north. With all our care they would be maggoty there and poor at times. This led us to growing them in summer in an open shed—that is, with a wall to the east, open to the west, and a thatched roof, and shaded by trees. Singularly enough we did not commence so soon as usual this year in the shed, and though we suffered a little from ricketty platforms that gave way in the house referred to, the last piece in the house has yielded fine Mushrooms up to the present time, notwithstanding the heat, and is doing so still. Our last piece in the open shed of last year, some 15 inches deep, has also borne profusely. After being dry and pretty well exposed from November last year, we thought it too good to be dug out in the beginning of April. We gave it a good manure watering, and covered it with litter, and to-day has the bed rewarded us. We think most failures are owing to mistaken kindness. In a house, at this season we should damp walls, paths, &c. to promote coolness. In a shed, or in the open air, we should cover, and do cover, for the same purpose—to keep the beds cool. The best Mushrooms are produced at a temperature rather under than above 60°; hence sheds, cellars, and cool places are better than common houses in summer. After all, Mushrooms are often a fickle crop. For many years we have not known what it is to have a failure, and yet it is possible we may soon have an unproductive bed, and scarcely be able to assign the reason why. We have entered into details several times, telling how to vary the treatment according to the material. As to the material, we are not at all particular, provided we can get a few horse droppings for the purpose. If you told us exactly how you managed your bed, we might be able to find out where the error is. Meanwhile, we attribute the "going off" to too close and too warm an atmosphere.

ARTILLERY PLANT (*J. E. B.*).—The botanical name is *Pilea muscosa* formerly it was called *Urtica microphylla*, but never *Thelygonum cyanocrambe*, which is quite a different plant, though belonging to the same natural order.

WEEK'S ONE-BOILER SYSTEM (*Clericus*).—The best example we know is at Manley Hall, near Manchester. If you write to Messrs. Weeks, King's Road, Chelsea, they would send you a drawing of what they have done at Manley Hall. There are three boilers, and these heat houses of all kinds requiring 14,447 feet of piping.

POTATOES ONION-FLAVOURED (*Cornwall*).—The flavour could not arise from the sets being stored with Onions, nor from being grown in a soil where Onions were the preceding crop. The saucepan or the water, or some contact after boiling, we think, must originate the disagreeable flavour.

EARNINGS (*A. S. L. M.*).—We do not know of any better traps than pots stuffed with moss. They may be poisoned, but care must be taken to keep the baits from other animals. Equal proportions of honey and arsenic will destroy all that partake of it.

BRIGHT (*Liphis*).—When the composition is ready for the public and advertised, will be the first time to publish testimonials in its favour.

GLOWWORMS (*Poplar*).—The glowworm is the fully developed, although wingless, female of a species of beetle of which the male is winged. Insects when arrived at the fully-developed state only live till they have paired, and the females deposited their eggs. Hence the chances are very slight that you could keep glowworms on a lawn for more than a short time, certainly not during the winter. They feed both in the larva and full-grown state upon snails and other soft-bodied creatures.—I. O. W.

INSECTS (*G. J.*).—There was not any leaf in your letter when it reached us. Send again. (*H. D. B.*)—The insect injuring your Vines is *Cucurlio picipes*, the chry-coloured weevil. The only remedy is to go at night with a light, hold a sieve beneath each branch with one hand, and shake the branch gently with the other hand; the weevils that may be on the branch immediately drop.

POULTRY, BEE, AND PIGEON CHRONICLE.

RATIONAL POULTRY-KEEPING.—No. 5.

There are few places that are not within reach of a market town, and in all markets there is a sale for poultry. Where

no sale exists, either it has been given up because it was seldom any poultry was to be had, and more frequently still, because when bought the chickens (?) were so hard they were unactable. The first reason is unavoidable, because at some seasons of the year there is little spare poultry, but the second is the result of such false calculation and management that it savours of folly. It was pardonable only in the days when the cost of carriage by stage coach was so great that it did not pay to send a couple or two of chickens, and the time consumed in the journey made the wagon more than useless, and when there were no men who made it a business to collect fowls, or where a sale could be had for one or two couples weekly and no more. They were then killed as they were wanted, and if the stock was large, by the time the last were sent to market they had attained an age that rather fitted them for continuing their breed than for supplying food in their own persons. Now, however, it is different. In almost every village in England, if near a railway station, there is a man who makes it his business to collect poultry of all kinds, eggs, butter, &c., to send either to some county capital or to the metropolis. He will buy the surplus stock, and, mind, it is more valuable to him and more profitable to you if it is young.

But we may be met with the answer, "We do not live near a town. There is no man who collects. We have no means of selling. We will not be bothered with fattening in any shape. We do not know what to do with them. Drot the fowls, we wish we had never seen them." He has a bad counsellor who listens to his anger, and many a possessor of good birds has had his momentary fit taken advantage of, and has sold for a trifle a lot of birds that in cooler moments he would, but for shame's sake, have bought back at a large increase. These fits of anger with the birds are generally caused by an unusually heavy bill for food, or a demand for an increased quantity, or a complaint of the damage they do in the garden, or a fit of the "blues."

Now, it is undeniably true that the fewer fowls you have on the ground the better they will thrive. The best will make a good return for all your food and painstaking, the family can make no other return than to appear on your table, and that is where all this verbiage is to lead us. It is in every way a saving to kill them young, and we will admit they are too small either to roast or boil—as cook says, "Lor, there ain't nothin on 'em, what will they be when they're roasted?" True, good cook; but if you had been a Sussex woman you would have said, "Two of them would make a beautiful pudding."

Say you have some chickens so faulty that there is no hope of their getting right, so ugly they will never be pretty, so crooked they will never be straight. You have so many you look on them every day with an evil eye; and when your man tells you the fox visited Dame Partlett's brood last night, you say in your bitterness you wish he would visit yours. Take some, according to the size of the pudding you require, of the least promising or most offending of your chickens, put them away to fast during six or seven hours, kill them, have them picked quite clean, hang them in a cool larder for a day and night, and then proceed to cut them up, but do it properly. We have heard the cut of a coat criticised by its being said it looked as though it was chopped out with a spade, and we have seen chickens cut up as though the operation had been performed with a hatchet. First take out the crop, then take out all the inside; cut off the feet, and put them in nearly boiling water—all the skin will then easily peel off; put them, the neck, the gizzard (having first taken out the inside), the liver, and heart, in a small quantity of water, and let them boil for gravy. Put the chicken on a table on its back with the crop towards you; take a sharp knife, and cut from the point of the breastbone to the wing, being careful to keep the edge of the knife against the bone all the time, that no meat may remain on the carcase; raise the meat that is divided, and remove it wherever it adheres to the bone. This gives you a delicious wing. One of these will come from each side of the breastbone, and will leave it denuded of meat. These are the two choicest pieces. Next remove the two legs and divide each at the joint, making thigh and drumstick of each; then the wings, cut them off, and divide at the principal joint. You will then have a small merrythought and two small side bones. Lay the carcase on its side, and chop it in half lengthwise. If you have followed our instructions closely there will be little or nothing left on the breastbone; nevertheless, put it in the saucepan that is already turning water into gravy. Then divide the backbone just below the oyster-pieces, and flatten them with a good blow of the flat side of the chopper.

Thus from each chicken you have two slices of breast, two thighs, two drumsticks, a merrythought, two side bones, the wings, and two succulent pieces of back. Next take three or four thin slices of salted pork and put with them. It is a wonderful improvement to cut up two sheep's kidneys and add to it. Luxurious people put ham instead of pork, and some "go the whole hog" by adding mushroom and a few oysters. As we are not writing for them, we will return to our plain dissected chicken and our slices of pork. Season them to your taste. Then make a nice suet crust. Take a basin according to the size you desire, line it well with the crust, and then dispose your pieces artistically as though you were making mosaic work—do not throw them in. Pour in your gravy, tie the basin with a cloth, and boil long and gently. If our description is correct, and you like it as well as we do, your chickens will be benefactors instead of plagues, and you will often ask yourself whether they are large enough for a chicken pudding.

DAMAGING FOWLS AT SHOWS.

Last year I exhibited at Spalding a very good pen of Duckwings; they having during the few previous months won cups at Bristol, King's Lynn, Hull, Beverley, and Thorne, besides first prizes at Leeds, Utverston, &c. Thorne Show took place just a week before Spalding, and this pen had only been left about a quarter of an hour, during which time one of the cock's sickles was broken. Happening to arrive at Thorne just before the Game classes were judged, I took the bird out of the pen, and arranged the broken feather so that it kept its place during the Show, and the pen won the cup. Feeling convinced that the feather had been wilfully broken, I wrote to the Secretary of the Spalding Show explaining the matter, and asked him as a favour to let special attention be paid to this pen, yet this did not prevent the cock coming back with the other sickle broken. As it was, the birds were first in their own class, and had they not met with foul play would most probably have won the cup for the best pen of Game fowls in the Show.

I have been an exhibitor of Game fowls for upwards of a dozen years, during which time I have had several Game cocks returned with the sickles broken or out entirely, and this never happened to any but my very best fowls, proving to my mind that the majority of these cases are the work of unprincipled exhibitors, who take advantage of any chance to get rid of a troublesome pen.—H. M. JULIAN, Hull.

DRIGHLINGTON AND ADWALTON POULTRY SHOW.

The annual Show of the Drighlington and Adwalton Agricultural Society took place on the 9th inst., and the weather being very fine the visitors were numerous. In the poultry department the numbers were not large, in consequence of so many shows having been held during the few preceding days, and the fact that a similar show was held simultaneously about two miles off.

Spanish were first on the list, but these, the *Dockings*, and the *Cochins*, were but moderate in quality. The only pen of *Brahmas* was very good, and of Red *Game* the birds were excellent and close-feathered. The first-prize winners were Brown Reds, and the cup for the best pen was awarded to these. The second prize went to Black Reds. All the *Hamburghs* were good, but the Black were especially noteworthy. The *Creve-Coeurs* in the *French* classes were of extraordinary merit. The cup for the best pen except *Game* was won with *Polands* of the Golden variety. For single cocks *Game* was first, a *Poland* second, and a *Cochin* third. Of *Game Bantams*, a pretty pen of *Duckwings* was first, and Brown Reds of capital style and colour were second. *Ducks* and *Geese* were large and good in all points.

The *Pigeons* were more numerous than the poultry, and the birds shown were of high merit. In *Carrers*, Mr. Horner won with 2 good pair of Black, closely pressed by a neat pair from Mr. Yardley. In the class for *Pouters*, Red were first and Blue second. *Almond Tumblers* were well shown, and the competition close. The Black *Barbs* in the first-prize pen were extraordinary birds, especially the cock, which is about the best we have seen. *Antwerps* were in large numbers, and good in head, beak, and feather. In the *Tarbit* class Blue were first and Red second, and the winning Red *Jacobins* were good in all points. The *Trumpeters* were fine, well-feathered birds, and good in rose and size.

SPANISH.—1, H. Beldon, Goitstock, Bingley. 2, W. Schofield, Gildersome. DORINGS.—1, H. Beldon. COCHINS.—1, J. White, Whiteley, Netherpton. 2, C. Sidgwick, Keighley. BRAHMA POOTRA.—1, H. Beldon. GAME.—Black-brasted or other Red.—Cup and 1, H. Bealand, Westgate Hill. 2, T. Broomley, Shelf. *hc*, H. Walker, Drub, Gomersal; J. Fell, Adwalton. *Duck-winged or other Grey or Blue*.—1, J. Fell. *Any other Variety*.—1, E. Walker, Gomersal. 2, J. Clayton, Gomersal. HAMBURGERS.—Golden-spangled.—1, H. Beldon. Silver-spangled.—1, H. Beldon. Golden-pencilled.—1, A. Smith, Northowram. 2, H. Beldon. Silver-pencilled.—1, H. Beldon. Black.—1 and 2, H. W. Illingworth, Idle. *hc*, H. Beldon; C. Sidgwick. FRENCH.—1, H. Beldon.

ANY OTHER VARIETY.—Cup and 1, H. Beldon. 2, J. S. Snowdon, Adwalton. *Cock*.—1, W. Fell. 2, H. Beldon. 3, C. Sidgwick. *hc*, H. Bealand, BASTAM.—*Game*.—1, W. F. Entwisle, Cleckheaton. 2, W. Greaves, Bradford. *hc*, W. F. Entwisle; J. Walker, Adwalton. *Any other Variety*.—1, H. Beldon. 2, T. E. Harrison, Hull. *GESE* (any breed).—1, J. White, Netherpton. 2, J. Ward, Drighlington. *Ducks*.—Aylesbury.—2, T. Wilson, Crosshill. *Eggs*.—1, J. White, 2, C. Sidgwick.

PIGEONS.

CARRIERS.—1, E. Horner, Harewood. 2, H. Yardley, Birmingham. *hc*, J. Hawley, Bingley; E. Horner, POTTERS.—1, J. Hawley. 2, E. Horner. *hc*, H. Yardley. *TUMBLERS*.—*Almond*.—1, E. Horner. 2, H. Yardley. *Any other Variety*.—1, H. Yardley. 2, J. Hawley. *BARBS*.—1 and *hc*, E. Horner. 2, H. Yardley. *ANTWERPS*.—1, J. Crossland, Wakefield. 2, E. Horner. *Extra* 2, J. Hawley. *hc*, H. Yardley; J. Crossland (2). *TURBITS*.—1, H. Yardley. 2, T. Holliday, Idle. *hc*, E. Horner (2). *FANTAILS*.—1, H. Yardley. 2, E. Horner. *hc*, J. Hawley; E. Horner. *JACOBSINS*.—1 and 2, E. Horner. *hc*, H. Yardley. *TRUMPETERS*.—1, E. Horner. 2, J. Hawley. *hc*, J. Hawley; W. Tetley, Birkenshaw. *MAGPIES*.—1, E. Horner. 2, H. Yardley. *hc*, T. Halliday. *ANY OTHER VARIETY*.—1, H. Yardley. 2, E. Horner. *hc*, J. Hawley. *MEDAL* for greatest number of points in Pigeon classes, E. Horner.

The Judge was Mr. E. Hutton, Pudsey, Leeds.

SNAITH POULTRY SHOW.

The sixteenth annual Show of the Snaith Agricultural Society took place in the grounds of Mrs. Shearburn on the 5th inst. This park is well studded with trees, and the pens were well sheltered from the sun, which was a great boon, as the day was excessively hot.

The *Game* in the class for Reds was very good, and the competition keen. The second-prize pen was only so placed through the cock being slightly crooked in the breast. In the class for any other variety of *Game* Mr. Sales showed a first-rate *Pile* cock. The *Spanish* class contained some of the best birds in the country, and the timepiece awarded to the best pen in the Show was won by birds of this variety. The *Cochins* belonging to Mr. W. A. Taylor were Partridges of high quality. The winning *Hamburghs* were good in all classes. Of *Game Bantams*, a handsome pair of Black-breasted Reds were first; the second and third-prize birds were also good in style, but in bad condition. For *Bantams* of any other variety Blacks were first, Japanese second, and *Schrights* third. *Creve-Coeurs* were first in the "Variety" class, *Polands* second, and *Dorkings* third. Mr. Brierley was first in the single-cock class with a splendid Black-breasted Red *Game*, which was one of the best birds we have seen for some time.

Of *Pigeons*, the winning *Jacobins* were good in hood and chain, and the *Fantails* were also in good order. There was, in addition, a good but small show of cage birds.

GAME.—Black or other Red.—1, E. Ackroyd, Eedeshill. 2 and *hc*, F. Sales, Crowle. 3, J. Brierley, Middleton. *Any other Variety*.—1, F. Sales. 2, J. Stabler, Driffield. 3, C. Brierley. *hc*, E. Ackroyd. SNAITH.—Black—Time piece and 1, H. Beldon, Bingley. 2, Rev. J. Price, Haddisley. 3, T. O. Newbitt, Epworth. *Cochin-China*.—1, W. A. Taylor, Manchester. 2, J. Brierley. 3, J. Wakefield. *hc*, J. Torton, Ackworth. *HAMBURGERS*.—Golden-spangled.—1, H. Beldon. 2, G. Holmes, Driffield. Silver-spangled.—1, H. Beldon. Golden-pencilled.—1, H. Beldon. 2, G. Holmes. 3, D. White. Silver-pencilled.—1, H. Beldon. 2, W. A. Taylor. 3, T. Dawson. BANTAMS.—*Game*.—1, J. Oldroyd, Wakefield. 2 and 3, J. E. Robinson. *Any other Variety*.—1, T. C. Newbitt. 2, H. Beldon. 3, T. C. Harrison, Hull. *ANY OTHER VARIETY*.—1 and 2, H. Beldon. 3, W. Purdon, Driffield. *hc*, H. Beldon; W. D. White, Driffield. *Cock*.—1, C. Brierley. 2, W. A. Taylor. 3, H. Beldon. *Ducks*.—1, Wakefield. 2, T. C. Harrison. *GESE* FOWLS.—1, T. C. Harrison. 2, Mrs. W. Broadley. 3, O. A. Young, Driffield.

PIGEONS.

TUMBLERS.—3, R. Simpson, Selby. *JACOBSINS*.—1, W. White. 2 and *hc*, T. C. Newbitt. *TERTS*.—1, T. C. Newbitt. 2, E. Bairdson. *FANTAILS*.—1, T. C. Newbitt. 2, E. Harrison. *EGGS*.—1, S. Robinson. *ANY VARIETY*.—1 and 2, S. Robinson. *Extra* 2, T. C. Newbitt.

CANARY.—1, T. W. Dickinson, Doncaster. 2, A. J. Wells, Hatfield. *hc*, T. Fosbrooke; A. J. Wells (2). *ANY OTHER VARIETY OF BIRD*.—1, G. Trimmingham. 2, F. Higgins.

The Judge was Mr. E. Hutton, Pudsey, Leeds.

BOSTON POULTRY SHOW.

The first Show of this kind held at Boston took place on the 5th inst., and as regards the number of entries and the attendance of visitors, it was a great success. Being a first attempt, the arrangements were scarcely so perfect as in all probability the experience now obtained will make those of future years.

Of *Dockings*, the majority were, unfortunately, much deformed in the feet, though otherwise excellent birds. *Cochins*, though not numerous, were good. *Spanish*, though first-rate, were mostly very deficient in condition. The Dark *Brahmas* were an excellent class, and as regards *Game* fowls, it is very unusual to meet with such excellent classes, the birds shown by Mr. C. Chaloner in the various *Game* classes being such as to excite the admiration of all who saw them; these, together with the prize *Game Bantams*, were shown in the most perfect condition possible. *Hamburghs* were throughout well shown, but the season now tells much against the beauty of the adult birds, and the whole of their plumage is fast becoming faded and shabby, their annual molting time being at hand. The *Water Fowls* were decidedly good, and the show of *Pigeons* was such as might be envied by the managers of much larger and long-established shows. There was also a very interesting and popular display of *Parrots*, *Canaries*, fancy song birds, both English and Foreign, and *Rabbits*. The poultry were exhibited in the well-known pens of Mr. Turner, of Sheffield.

DORINGS.—1, J. Watts, King's Heath, Birmingham. 2, G. Andrews, Tuxford. 3, R. Wood, Clayton, near Thrapstone. COCHIN-CHINA.—Cinnamon and Buff.—1 and *Cap*, J. Cattell, Birmingham. 2, W. Gamon, Chester. *hc*, W. Harvey, Sheffield. 3, Rev. J. Spencer, Atterborough. *Any other Variety*.—1, H. H. Bleis-

toe, Barnwell, Oundle. 2, Mrs. E. Barker, Leverton. **BRANMAS.**—*Dark.*—1, C. Chaloner, Whitwell, Chesterfield. 2, J. H. Dawes, Birmingham. *hc, J. Waite, King's Heath, Birmingham; W. Gamon, Spanish.*—1 and Medal, T. & C. Newbitt, Epworth. 2, J. Dixon, Cotgrave, Nottingham. **GAME.**—*Black-breasted Red.*—1 and Cup, C. Chaloner. 2.—Hales, Crowle. *hc, J. Laming, Cowburn, Spalding; H. M. Julian, Hull. Brown-breasted Red.*—1, C. Chaloner. 2, J. Laming. *Any other Variety.*—1, J. Laming. 2, T. Matthew, Stowmarket. *hc, H. M. Julian. c, C. Chaloner. HAMDBONS.*—*Golden-pencilled.*—1 and Cup, H. Pickles, Earby, Skipton. 2, J. Laming. *Silver-pencilled.*—1, J. Laming. 2, H. Pickles. *Golden-pencilled.*—1, H. Pickles. 2, W. Driver, Keighley. *hc, J. Laming. c, R. D. Byrne, Boston; Lovelidge, Newark. Silver-pencilled.*—1 and Medal, J. H. J. Pickles. 2, J. Laming. *hc, S. H. Ashton, Mottram. BANTAMS.*—*Game.*—1 and Medal, C. Clisner. 2, H. Snushall, Wisbeach. *c, F. Entwisle, Westfield, Cleckheaton. Any Variety.*—1, S. & R. Ashton. 2, T. C. Harrison. *hc, S. S. Mossop, Long Sutton. c, J. Watts, King's Heath, Birmingham (2); J. Laming; T. & C. Newbitt; A. Storrer, Peterborough. HEAVIEST.*—1, Withheld. 2, G. Bonner, Boston. **DUCKS.**—*Any Variety.*—1, R. W. Richardson, Beverley. 2, T. C. Harrison. *hc, S. & R. Ashton. SELLING CLASS.*—1, W. Harvey. 2, J. T. Dixon.

PIGEONS.

CARRIERS.—1 and Medal, H. Yardley, Birmingham. 2 and C. R. Fulton, Deptford. **POUTERS.**—1 and 2, R. Fulton. *c, W. Harvey. TUMBLERS.*—*Almond.*—1 and 2, R. Fulton. *hc, J. Ford; W. Harvey. TUMBLERS.*—1 and 2, R. Fulton. *c, W. Woodhouse, West Wynch, Lynn. BARS.*—1, Medal, and 2, R. Fulton. *c, W. Harvey. PASTALS.*—1, T. & C. Newbitt. 2.—*Loversidge. c, W. Harvey. TORRETS.*—1, J. H. Yardley, Birmingham. *c, R. Fulton. W. Harvey. ANTWEYS.*—1, H. Yardley. 2, J. Waite. *ANY VARIETY.*—1 and Medal, R. Fulton. 2, H. Yardley. *hc, J. Waite; J. Fielding, jun., Rochdale; W. Harvey (2). c, Hudson & Co., Epworth; T. & C. Newbitt; R. W. Richardson, Beverley. SELLING CLASS.*—1, Rev. C. Spencer. 2, W. Harvey.

CAGE BIRDS.

CANARY.—*Belgian.*—1, 2, and *hc, W. E. Smith, Boston. Norwich.*—1, W. E. Smith. 2.—*Allardyce, Boston. Mule.*—1 and 2, W. Woodhouse. *hc, Master Arkwright, Sutton Scarsdale. A. Bothamley, Wisbeach. LINNET, GOLDFINCH, &c.*—1, Woodhouse. 2, M. Crowden, Boston. *hc, H. J. Waite, Boston; E. S. Smith, Boston (2). H. Crowden; W. Thomas, Boston; T. Flower, Boston. LARK.*—1 and Clock, C. H. Muschamp, Boston. 2, E. S. Smith. *hc, J. H. Evans, Boston; C. H. Muschamp. THRUSH.*—1, R. D. Borne. 2, E. S. Smith. **BLACK-BIRD.**—1, C. Huggins. 2, R. D. Borne. *hc, E. S. Smith. PARROT.*—1, Mrs. T. Goodacre, Boston. 2.—*Allardyce. hc, J. H. Thomas, Boston. VARIEGATED PARROT, &c.*—1 and Clock, Miss M. Jenkins, Billingham Vicarage. 2, G. E. Storr, Spalding. *hc, G. W. Thomas. SMALL BIRDS.*—1, Mrs. Blenkiron. 2, B. Storr, Boston. *hc, T. Elmora.*

RABBITS.

ANY PURE BREED.—1, E. Vaughan, Birmingham. 2, J. Quick, St. John's Wood, London. *hc, H. G. Tunison, Barton-on-Umber; J. Quick, c. W. Tiffery, Long Sutton; S. G. Hudson, Hull. HEAVIEST.*—1, Master Arkwright. 2, J. Quick. *c, W. Taylor, Boston.*

Mr. Edward Hewitt, of Birmingham, was the Judge for *Poultry*, and Mr. Massey, of Spalding, for *Pigeons and Rabbits*.

CAMBRIDGESHIRE AND ISLE OF ELY AGRICULTURAL SOCIETY'S POULTRY SHOW.

This Society has now for a long succession of years added poultry to the varied objects of the annual Show, and experience proves that the display of poultry and Pigeons is perhaps one of the most attractive parts to the public generally. It is also now well known that the valuable specimens entrusted to the care of the Committee are treated with the greatest attention, and from this cause only few shows enjoy a larger amount of support. Grey *Dorkings* at the Show held at Royston on the 6th inst. were very good, the chickens more especially so, several pens of the latter being unusually well-grown for the present season. It is well to mention as a guide to intending exhibitors, that such malformations as gouty feet, deformed legs, or spurs set on the outside of the legs, are to be especially avoided as fatal objections in the choice of pens of Dorking chickens for exhibition. Singularly enough not a pen of White *Dorkings* was shown. As most poultry fanciers would anticipate, the collection of *Game* fowls was good, Messrs. Matthew and Hall being close competitors. The display of *French* fowls was far better than ordinary, though many of the best specimens were fast falling into deep moult. *Of Cochins and Brahmas* the classes were good, but the birds not in the best of plumage. The *Hamburghs and Poland*, for the neighbourhood, were better than usual. Still more worthy of mention were the *Game Bantams*; here Mr. Jeffries, of Ipswich, with two pens of his best birds secured both prizes. The class open to chickens of all breeds except *Dorkings* was a most interesting feature of this Show, and augurs well for a speedy entry at most of our coming meetings of a display of well-grown birds of the current year. *Turkeys and Ducks* were unmistakably excellent, and many of our agricultural friends appeared quite astonished at the size and perfection of the majority of the pens that were comprised in these classes. The entry of *Ornamental Water Fowls* was also remarkably good.

Pigeons formed an interesting portion of the display, and Mr. Fulton, of Deptford, though the chief prizetaker, with birds so well known, had a very close competition with other exhibitors in many of the classes.

The shedding in which the Show was held was excellent; and that such was provided, as it always is, was fortunate, as an extraordinarily heavy rain fell throughout the night preceding the Show, although the day of opening was as fine as could be wished, the result being an attendance of visitors almost unprecedented at any previous meeting of this Society.

DORKINGS.—1, J. K. Fowler, Aylesbury. 2, Rev. C. H. Grosse, Cambridge. *hc, Lord Dacre, Wicham, South Bucks.*—1, H. Yardley, Market Hall, Birmingham. 2, Lord Dacre. *hc, G. S. Hall, Ely. c, A. B. Simpson, Trumpington. Chickens.*—1, H. Yardley. 2, F. Parlett, Great Baddow. *hc, Lord Dacre. GAME.*—*Black-breasted or other Reds.*—1, S. Matthew, Stowmarket. 2, F. R. Hall, Cambridge. *hc, F. R. Hall; S. Matthew, Stowmarket. c, F. R. Hall. Any other Variety.*—1 and 2, S. Matthew. *hc, F. R. Hall; W. Bullen, Cambridge. FOLDINGS.*—1 and 2, W. O. Quibell, Newark. *hc, Lord Dacre. W. Dring, Faversham; J. P. Nunn, Boston. ANY OTHER FRENCH VARIETY.*—1, W. O. Quibell. 2, J. J. Milden. *c, J. K. Fowler, Aylesbury. SPANISH.*—1 and 2, F. James. *hc, F. Waller, Wood Green. c, G. S. Hall. COCHINS.*—1

1, H. Lingwood. 2, Mrs. Burrell. *hc, J. K. Fowler; R. W. Smith (Partridge); S. Felgate, Ipswich. BRAHMA POOTRA.*—1, H. Dowsett, Pleshey, Chelmsford. 2, H. Lingwood. *hc, Mrs. Burrell. c, J. S. Dew; J. P. Nunn, Royston; O. Stedd, Baldock. POLISH.*—1 and 2, W. K. Patricke. 2, Mrs. Burrell. **HAMBURGHS.**—*Golden or Silver-spangled.*—1, Miss C. E. Palmer. 2, J. T. Loversidge, Newark-on-Trent. *Golden or Silver-pencilled.*—1, W. K. Ticker, Ipswich. 2, Mrs. Burrell. *c, T. H. Court, Royston. BANTAMS.*—*Game, any Variety.*—1 and 2, W. B. Jeffries, Ipswich. *hc, Rev. C. H. Grosse; H. Dowsett, Chelmsford. c, Miss E. M. Thurnall, Royston; J. Pring, Royston. Sebrights, Gold or Silver.*—1, G. S. Hall. 2, T. C. Harrison, Hull. *Any other Variety.*—1, T. C. Harrison. 2, G. S. Hall. *hc, Miss E. Nash, Carlton Grange. c, Miss M. Sanders, Royston; G. S. Hall. ANY OTHER VARIETY.*—1, Mrs. Burrell. **CHICKENS** (Any variety except *Dorkings*).—1, S. Matthew. 2, C. Layland. *hc, J. K. Fowler; J. J. Malden, Biggleswade; Hon. Miss Jervis, Royston. TORREYS (Any Variety); 1, E. Leech, Rochdale. 2, G. S. Hall. *hc, E. Arnold, Whitesford; T. Morton, Cambridgeshire. DUCKS.*—*Rouen.*—1, E. Leech. 2, J. K. Fowler. *c, G. S. Hall. Aylesbury.*—1, Mrs. M. Scamons. 2, J. K. Fowler. *hc, J. K. Fowler; Mrs. Burrell. Any other Variety.*—1, J. K. Fowler. 2, C. Harrison. *c, S. Stanley, Longstone Hall. EXTRA.*—1, Rev. C. H. Grosse; T. H. Court.*

PIGEONS.

CARRIERS.—1, R. Fulton, Deptford. 2, H. Yardley. *hc, R. Fulton; F. W. Metcalfe, Cambridge; Mrs. J. F. White, Birmingham. TUMBLERS.*—1 and 2, R. Fulton. *hc, J. M. Braid, Cambridge; H. Yardley. OWLS.*—1, G. S. Hall. 2, No competition. **POUTERS.**—1 and 2, R. Fulton. *hc, R. P. Payling, Peterborough; H. Yardley. c, R. Ruston, jun., Chatteris. BARS.*—1 and 2, R. Fulton. *hc, H. Yardley. PASTALS.*—1 and 2, H. Yardley. *ANY OTHER VARIETY.*—1 and 2, H. Yardley. *c, G. S. Hall (Jacobins).*

Edward Hewitt, Esq., of Sparkbrook, Birmingham, officiated as Judge.

MOULTON POULTRY SHOW.

This Show was held on the 6th inst., in the beautiful grounds of H. J. Little, Esq., The Thorpe-lands. The first-prize *Dorkings*, also the *hc Spanish, Brahmas*, and *Game* were very good, and would not have disgraced any Show. Among the *Pigeons* were some passable birds.

DORKINGS.—1 and 2, J. Longland, Grendon. **SPANISH.**—1 and Cup for best pen in Show, H. M. Cooper, Walsall. 2, C. Wright, Northampton. **GAME.**—1 and 2, B. Cox, Moulton. **COCHINS.**—1, J. H. Dawes, Moseley Hall, Birmingham. 2, W. F. Checkley, Moulton. **BRAHMA.**—1, G. F. Whitehouse, Birmingham. 2, W. Birch, Barnack, Coventry. **HAMBURGHS.**—1, W. Nottage, Northampton. 2, B. Cox. *hc, E. Knight, Meor's Ash; W. Collier, Dobb, Binley (2); P. Collins, Daventry. BANTAMS.*—1, T. Rogers, Walsall. 2, Mrs. F. Worley, Northampton. **SELLING CLASS.**—1, J. Brown, Moulton (Dorking). 2, T. Rogers, Walsall (*Bantams*). *hc, B. Cox (Game). DUCKS.*—*Aylesbury.*—1, Prize, Miss Merry, Moulton. Prize, J. Dove, Moulton. *Any other Variety.*—1, H. J. Hopkins, Moulton Grange Farm. 2, J. Brown.

PIGEONS.

CARRIERS.—1 and 2, J. Spence, Kettering. *hc, T. Adams, Northampton. TUMBLERS.*—1, C. Smith, Northampton. 2, G. Johnson. **POUTERS.—1, G. Johnson. 2, W. Nottage. **OWLS.**—1, W. Lepper, Northampton. 2, A. Bonser, Northampton. *ANY OTHER VARIETY.*—1 and 2, W. Nottage. *hc, G. Johnson (Jacobins). c, W. Lepper (White Dragons); T. Adams, Northampton. THREE PAIRS DISTINCT.*—Cup, T. Adams. **BARS** (Three Pairs).—1, W. Lepper.**

Mr. H. Yardley, Market Hall, Birmingham, was the Judge.

BISHOP AUCKLAND POULTRY SHOW.

The second annual Show took place on the 8th inst. Turner's pens were used, and were arranged in single tiers round the sides and through the middle of the marquee in which the Show was held. The arrangements were excellent, and great credit is due to the Committee. One gold cup, one silver cup, and two handsome gold medals, in addition to money prizes, were given, and the entries were numerous, while the quality of the birds was excellent in most of the classes.

Dorkings were in no respect noteworthy, but the *Cochins* very fine. The pen of White shown by Mr. Proctor was quite perfect, if we except the comb of the cock, which is rather plain. Of *Brahma Pootras* there were some fine specimens, a cock shown by Mr. Stalker being of striking size, shape, and colour. *Spanish* were as good as could be desired, and the first-prize pen in this class won the gold cup for the best pen in the Show, and was claimed at £20 immediately on the opening of the Show to the visitors. *Polands* were a very good class, perhaps one of the best we ever saw considering the time of year. In the class for *Game*, Brown Reds were first and Black Reds second. The *Duckings* in the class for any variety of *Game* were wanting in condition and feather, and with the exception of the winner in the single *Game* cock class there was no bird worthy of notice. There were several good pens of *Hamburghs* in bad order, and not at all fit for exhibition, though those noticed in the prize list were in nice bloom and well shown. In the "Variety" class the first were *Cerve-Cerve*s of extraordinary proportions, and the second a fine pen of that almost extinct variety the *Malays*. The *Game Bantams* showed signs of moulting, and, as a whole, they were not a good lot, though the pair to which the first prize was awarded, also the local medal, were good Brown Reds. A neat pair of Blacks were first in the next class for Bantams, closely pressed by another pen of the same variety. For *Ducks* the Rev. J. Milner was first and second with good birds, and the single *Turkey* cocks were of large size and handsome colour. Brahmas were first in the selling class, Buff Cochins chickens second, and *Duckwing* Game third.

The show of *Pigeons* was a complete success, and the classes well filled with good birds. Of Carriers the first-prize birds were in fine order, good in style, beak, and eye, though perhaps not so long in beak as the second-prize birds, which, though young, were very large and long in beak. Pouters were good, especially the first-prize Whites, which were in fine showing order, of great size, and good in style and girth. Tumblers were shown in one class, and were mostly Almonds. The cock in the first-prize pen has an extraordinary skull, and the hen is also good. The second-prize birds are exceedingly small and

well broken in feather. The Barbs were good and in fine condition, but we did not consider the Owls good. Trumpeters were as good as we could wish for, although some were partly broken in feet feathers. The silver cup for the best pen in the Show was given to the first-prize pair in this class. These were Light Mottles, and, though rather smaller than some of the rest, they were very good in rose and leg-feathering. Fantails were rather broken in feather, but good in carriage. The winning Jacobins were Whites and Reds of good properties, and the local medal for the best Pigeons was awarded to the former pair. In the "Variety class" Red Magpies were first, Blue Brunswicks second, and Black Swallows third.

DORKINGS.—1, J. White, Warlawy. 2, W. Bearpark, Ainderby Steeple, North-allerton. *hc.* J. Shorthose, Newcastle-on-Tyne. **COCHINS.**—1 and 2, G. H. Proctor, Durham. *hc.* J. Shorthose. *c.* W. Canney, Bishop Auckland; W. Barnes, Thirsk. **BRAMA PODRAS.**—1, J. Stalker, West Sleekburn, Morpeth. 2, H. Beldon, Bingley. *hc.* J. Shorthose. *c.* G. Richmond, Barnningham, SPANISH. 1 and Gold Cup, H. Beldon. 2, H. Wilkinson, Earby, Skipton. *hc.* E. Brown, Sheffield. *c.* W. Bearpark. **POLISH.**—1 and 2, H. Beldon. 3, H. Pickles, jun., Skipton. 4, R. Moor, East Rainton. *hc.* G. Todd, Monkwearmouth; R. Parsons, Sleekburn Cottage. **GAME.**—*Black-breasted* or *other Bids.*—1, E. Arkroyd, Ecdeshill, Leeds. 2, J. Watson, Knaresborough. *hc.* M. Mycroft, Bedford. *c.* W. Bearpark; T. Horne, Towlaw. *Any Variety.*—1, J. Robson, Bishop Auckland. 2, W. Bearpark, Ainderby Steeple. **COCK.**—1, Bunzlau and Williamson, Garville, Durham. 2, E. Arkroyd. *c.* T. Metcalfe, Bishop Auckland. **HAMBURGERS.**—*Golden-splashed.*—1, G. Holmes, Great Driffield. 2, H. Beldon. 3, H. Pickles, jun., Skipton. *W. Bearpark.* *Silver-splashed.*—1, H. Beldon. 2, H. Pickles, jun. *hc.* D. Chubb, Northumberland. *c.* 4, Armstrong, Bellington. *Golden-pencilled.*—1, W. Hall, West Sleekburn, Morpeth. 2, H. Beldon. *hc.* G. Holmes. *Silver-pencilled.*—1, H. Beldon. 2, H. Pickles, jun. *hc.* W. Hall. *c.* W. Bearpark. **ANY OTHER VARIETY.**—1, H. Beldon. 2, R. Hawkins, Seaham. *hc.* Mrs. W. Wharton, Barnningham. **BANTAMS.**—*Game.*—1 and Local Medal, T. Robson, Bishop Auckland. 2, Bunzlau & Williamson, *hc.* R. & J. F. Baldwin, Newcastle; R. Pomington, Thirsk. *Any other Variety.*—1, H. Pickles, jun. 2, S. & R. Ashton, Merton. *hc.* H. Beldon; G. Arkinson, Croft. **DUCKS.** (Any variety).—1 and 2, Rev. J. G. Milner, Leyburn. **TERKEY COCK.**—1, J. T. Proud, Bishop Auckland. 2, —Johnson, High Beaumont, Darlington. *hc.* Mrs. Spencer, Helmington Hall. **GANES.**—1, J. T. Proud, Bishop Auckland. **SELLING CLASS.**—1, W. Atkinson, Bishop Auckland. 2, G. H. Proctor, Durham. 3, J. Robson. *hc.* J. Robson; J. T. Proud; R. Moore, East Rainton. *c.* C. Marshall, Durham.

FIGURES.

CARRIERS.—1, R. Thompson, Sunnybrow, near Willington; W. R. & H. O. Blenkinsopp, Newcastle. *hc.* H. Yardley, Birmingham. *c.* J. W. Towerson, Easington; E. Brown, Sheffield; T. W. Kilburn, Bishop Auckland. **BARTERS.**—1, H. Hawley, Ringley. 2, J. W. Towerson, Whitehaven. *hc.* H. Yardley; T. W. Kilburn, Bishop Auckland; J. & W. Rowell, Tanfield, Newcastle. *c.* H. Cockton, Middlesbrough. **TUMBLERS** (Any variety).—1, W. R. & H. O. Blenkinsopp. 2, J. Hawley. *hc.* J. & W. Kowell. *c.* J. W. Towerson; T. Coundon, Sunderland. **BAHNS.**—1, H. Yardley. 2, J. Adamson, Low Beechburn. *hc.* W. R. & H. O. Blenkinsopp; T. W. Kilburn. **OWLS.**—1, W. R. & H. O. Blenkinsopp. 2, J. Hawley. *hc.* T. W. Kilburn; W. R. & H. O. Blenkinsopp; R. Wilson; R. Thompson. **CAT-PEPPERS.**—1 and Silver Cup, W. B. Van Haansbergen, Newcastle. 2, J. Hawley. *hc.* T. Rule, Durham; R. Wilson, Thirsk; K. Thompson. *c.* H. W. Bruno, Richmond; J. Cundale, Ripon. **PANTALS.**—1, H. Yardley. 2, T. C. Taylor, Middlesbrough. *hc.* W. B. Van Haansbergen; T. Rule (2). **JACOBINS.**—1 and Local Medal, T. W. Kilburn. 2, W. R. & H. O. Blenkinsopp. *hc.* J. W. Towerson; H. Yardley; T. Rule; G. Adamson; R. Wilson; W. R. & H. O. Blenkinsopp. **PENALTS.**—1, W. R. & H. O. Blenkinsopp. 2, H. Yardley. *hc.* T. Rule. *c.* R. Wilson. **NITS.**—1, W. B. Van Haansbergen. 2, R. Wilson. *hc.* H. Yardley; W. Bearpark. **DRAAGHS** or **ANTWERPS.**—1, R. Brown. 2, H. Yardley. *hc.* H. Yardley; J. Cundale; G. Sadler, Boroughbridge. *c.* J. & W. Rowell. **ANY OTHER VARIETY.**—1, Hudson & Burnip. 3, W. Bearpark. *hc.* J. Hawley; J. Cundale; R. Wilson; T. W. Kilburn. **SELLING CLASS.**—1, W. B. Van Haansbergen. 2, T. W. Kilburn. 3, R. & J. F. Baldwin. *hc.* H. Brown; T. Coundon; T. C. Taylor. *c.* J. Hawley; J. Cundale; W. B. Van Haansbergen (2) Mr. E. Hutton, of Pudsey, was the Judge.

RABBITS AND THEIR VARIETIES.

SINCE my removal from Prestwich my time has been so very fully occupied and so much of it spent from home, that our "furry friends" have not had the attention devoted to them I could have wished; but now I hope to see more of them, and shall be able to say a word or two on their behalf when required and opportunity presents. And the fact of my ceasing to exhibit, as for the past three or four years so successfully, must not be considered by my fellow exhibitors as a proof that I lack the interest I once had in this portion of our great shows, for I still keep up the excellent prize-winning stock in every variety as before. I have now eighty specimens of all ages in my rabbitry, and I always anxiously look over the returns of the prize-winners as given in "our Journal" (and I regret they are not more detailed) to see who is the fortunate owner of the specimen so perfect as to secure the high honour awarded by the judge in attendance.

SILVER-GREY OR CHINCHILLA.

Respecting this lively creature much may be said in its favour, its glossy silky hair being so prized by the furrier. In Siam (Indo-China) this animal is found in the greatest numbers and state of perfection. A variety of shades are now found in this country as the result of our colder temperature, and the experiments of re-crossing with darker or almost black specimens; and I know of few, if any, kinds where a greater variety of shade may be produced. I have long experimented in producing this variety, and have arrived at the conclusion that the more silver-like the specimen is marked all over, the more perfect. Black feet, ears, and faces generally are objectionable, and as a hint to all breeders, I would say, Pair two that are perfectly silvered all over, and you need not fear the result.

This animal is not generally large; if of the true kind it is

about the weight of the Himalayan. A strong large animal called the "Lincolnshire Silver-Grey," or "Miller" by the furriers, with only a small sprinkling of the silvery hair, and at times also designated the "Silver Sprig," may be seen, and I have known them weigh 10 lbs. or more, but they are very dark in shade compared to the Chinchilla, which the real Silver-Grey Rabbit resembles, hence the term as applied to this mercurial little fellow. Of all the cute (to borrow a term from our transatlantic friends) creatures of the Rabbit family this is one, and generally not so docile nor so easy to tame as other varieties, as the Dutch or Angora, which if treated kindly are always ready to be petted. Yet with kindness it is wonderful what may be done, and the law of kindness should be strictly enforced in every rabbitry if your stock is to afford pleasure.

I think the active manner and cheerful temperament of this Rabbit always render it a favourite. All breeders know the young are born quite black, and when about six weeks old they present a greyish shade under the body, and this change extends over from five to seven months, according to the temperature of the hutch; if warm, the process of silvering is sooner completed, the ears, neck, and head generally retaining the black shade longest. I have noticed the more jet black the young are at a month old, the more perfectly silvered they become at say eight months, so that I would not have young fanciers be afraid lest the jet black appearance be too great, and to lose hopes of the true silver shade appearing, but, in the words of a once popular song, I would say, "wait a little longer."

Warmth for all hutch Rabbits is of great importance, and this variety is by no means an exception, yet a hardy Rabbit generally, and with the requisite care by no means difficult to rear with success. I have generally had from fifty to seventy of this variety alone born in my rabbitry every year, and I suppose that during the last three years and a half from eleven to twelve hundred have been born of the seven varieties I keep.

The doe is rather shy, especially when about to have young, and seems very much afraid, when the nest is made, that it may be interfered with. She watches with an anxious eye every motion of the hand when placed inside the hutch, to see if her private domain is to be intruded upon, and I have known any such intrusion punished by the total neglect of the litter. The does seem to prefer, when about to litter, a rather dark but clean corner of the hutch, and should have plenty of fresh hay and water, or if milk and bread all the better to quench the intense thirst experienced at that time. In fact, milk and bread are no objectionable breakfast at all times for the first two or three weeks, if to be had. The Belgian Hare Rabbit is rather an exception to some of the other varieties, especially the one in question, for I have known does make their nests quite opposite the wire door, as though not in the least ashamed for the lookers-on to see what a important event has happened since the last visit.

The Silver-Grey doe generally brings forth from five to eight at each litter, but should not be allowed to pair until nine months old at the earliest, if fine and strong specimens are required for exhibition, and the litters should be at intervals of not less than ten or twelve weeks, to keep up the strength of the doe.

I have always, when opportunity presented, tried to obtain all the information possible from "fanciers" (breeders I mean), and have taken a peep on all occasions at the specimens of my prize-winning friends in all parts of the country. I am always glad to see any one here to look over my stock, and I hope, ever ready to give any information or useful hint to insure their success as breeders of the various varieties of fancy Rabbits.

In conclusion I beg to thank all those numerous friends from whom I have received so many letters in reference to my previous remarks on the other varieties, and I can only say that the information I may possess as a breeder of every known variety of Rabbit is quite at the service of any correspondent who will take the trouble to write to me.—CHARLES RAYSON, Ivy Lodge, Didsbury, near Manchester.

VEGETABLES BETTER THAN NOTHING.

As this touches a point I have long felt interesting, I venture to trouble you upon the subject, as, if an improved diet could be introduced, it would prove a comfort to many. Foreign workpeople have told me they found it impossible to keep strong here with the same mode of living as they followed in their own country; but soups made from vegetables, the water in which meat has been boiled, with pieces of bread added, would provide an occasional wholesome meal. But this wants slow

and careful cooking, and working people cannot spare time for this, and our open stoves make firing expensive. One plan would be to add a kitchen to the national schools, teach the children cheap cookery, and make it self-supporting by selling. Food well cooked would add to the comfort of a poor man's home, and save him from other temptations.—E. M. MAJOR.

NADIRING—HEATH PASTURAGE.

I HAVE placed several hives filled with comb, or empty, below other strong stocks; in these the bees work well, but as the upper hives only receive air through some twenty inch-holes, is there not fear of dysentery? My hope is to obtain artificial swarms in the lower hives to supply great losses caused by the late disastrous winter.

A few miles distant we have large heaths of ling; if I carry weak swarms to it when in bloom, can you tell me how much assistance I may expect them to obtain from it? Will it be such a second honey harvest as to enable a swarm, driven into a hive with comb, to get honey enough for the winter? Will it also encourage the queen to increase the laying of eggs? Can you tell me how long ling generally remains in flower? also, if a removal of four miles would be a sufficient distance to prevent the return of bees? The nearest ling heaths are about two miles away, but I do not think my bees go to them for honey.

I have been rather successful for some years past in obtaining artificial swarms from wild bees in roofs, trees, &c. Would any account of my method be of use to your Journal?—A. J. F.

[The stocks which you have nadired are in no danger of dysentery, but we cannot see how you can hope to get artificial swarms in the lower hives, which, moreover, are very likely to contain an undue proportion of drone-comb.

The heather will in some seasons remain in bloom four or five weeks, or even more; in others, such as this seems likely to be, the flowers wither much more speedily. Mr. Isaac states that a weak swarm sent to the heath on the 30th of July returned two months afterwards with an increase of 24½ lbs.; but this is a result much beyond what we have been able to obtain. It is, therefore, questionable whether a swarm driven into a combed hive may be able to store sufficient for the winter, but the supplementary honey harvest will certainly stimulate the queen to increased egg-laying. Bees will not return from a distance of four miles.

We shall be glad of an account of your method of obtaining artificial swarms from wild bees in hollow trees, &c.]

OUR LETTER BOX.

JUDGING GAME COCKS (C. W.).—Game cocks are not judged by weight. They are judged for colour, symmetry, and hard feather. This latter is an important point, and feeding for weight often has the effect of making soft feather. Good barley, a little bread and beer, sometimes a scrap or two of raw meat, and a few old peas given every other day, are supposed to make good plumage.

DIARRHEEA IN FOWLS AND PIGEONS (Subscriber).—We always give chalk made into pills, sometimes a few grains of hempseed, and in urgent cases a spoonful of brandy and water.

WHITE AND BLACK FOWLS (Experiential).—No cross is necessary to produce White and Black Bantams, as they exist as recognised breeds. The White Cochins also exist. Black could not hold their own, as they constantly betrayed a mixed origin. In the days when Black Cochins were attempted and sometimes shown, it was said they were bred between a Buff Hen and a White cock.

CROSS BETWEEN A DORING AND GUINEA FOWL (H. W.).—The cross in question has been seen, and we have seen it, but it is so rare we hardly ever expect to see it again. If you mean to persevere, we advise you to keep the same birds together always, and to allow no others to associate with them.

SPURLESS COCK—ROUP SYMPTOMS (Hamburg).—A cock need not be disqualified because his spurs are cut off. The description of the hen is that of the early stages of roup. She must be purged with castor oil. You should give Baily's pills. If you have them not, or do not care for them, give a couple of camphor pills each the size of a garden pea. It is wise to separate this bird from the others.

EXHIBITING GOLDEN-PENCILLED HAMBURG CHICKENS (Northern Subscriber).—The age at which the chickens can be shown with a prospect of success, will depend on the age of those they have to compete against. In many of the good strains we have seen the chickens, especially the pullets, beautifully marked at from four to five months old. To be shown advantageously the cock should be older than the pullets, as he retains his chicken feathers longer than they do.

BRAHMA HENS' FEATHERS BROKEN (M. W.).—It is too late now to pull the stumps of the feathers out of the backs of your hens. They would not grow in a month. Take the cock away from them. The feathers will come as good in colour as before, unless the process of pulling them out is constantly repeated. In that case they often come white.

FOWLS ROPY (J. G.).—You are not prodigal of information. How large is your earth run? Is the dung heap merely a heap of rubbish, or is it the wholesome sweepings of a well-ordered stable? When you say you feed on barley, is that all the fowls have? We gather so from

your letter. Roup does not interfere with fattening. Feed your birds on barley meal or ground oats. Vary this with a little mize from time to time. Give them a little bread and ale, and to the sickly ones give two camphor pills, each the size of a garden pea. You may give these every night till they make a cure. It is always well to remove sickly birds from healthy.

TESTIMONIAL TO MR. DIXON.—Mr. T. C. Harrison, Beverley Road, Hull, writes to us to say that he will subscribe 10s. 6d. Subscribers had better write to Mr. Hutton, and when the subscription list is completed we will publish it.

HAVE VERY LIGHT (C. T.).—If the hive continues light, we should deem it useless to put on a super.

BEES TAKING LIME-WATER (F. Roberts).—We have had no experience of the effects of lime-water on bees, but do not fancy that yours will have sustained any injury. Water is generally supposed to be essential to bees during the breeding season, but they seem most capricious in this respect, at one time collecting it with the utmost avidity, and then without any apparent reason suddenly disregarding it altogether.

BEES NOT SWARMING, &c. (A Bee-lover).—We fancy the size to your difficulty may be found in the fact that the hive which you purchased was "small" and at the same time "very heavy." When, therefore, the winter was over the poor queen found but a restricted breeding space at her command, which, as the overwhelmingly good honey season set in, became more and more contracted, so that she has been in difficulties ever since, and has never been able to raise her colony to the drone-breeding pitch in respect of population. There is much in what Mr. Pettigrew has advanced concerning large hives, whilst there can be no question as to the propriety of utterly eschewing very small ones. You had better, therefore, appropriate the contents of your honey-choked hive in the autumn by driving the remaining bees and uniting them to your contemplated new purchase, which might in this case take their place in the apiary.

RASPBERRY VINEGAR (T. L.).—Put a quart of raspberries into a quart of the best vinegar, and let them stand a week, stirring them occasionally; then add 1 lb. of loaf sugar, boil slowly twenty minutes, strain, and bottle.

METEOROLOGICAL OBSERVATIONS

In the Suburbs of London for the week ending July 12th.

Table with columns: DATE, BAROMETER (Max, Min), THERMOMETER (Air: Max, Min; Earth: 1 ft, 2 ft), Wind, Rain. Rows include Wed., Thurs., Fri., Sat., Sun., Mon., Tues., and Mean.

- 6.—Fine; cloudy but fine; densely overcast.
7.—Foggy; very fine; clear and very fine.
8.—Very fine; exceedingly fine; overcast.
9.—Fine; showery; overcast; very fine.
10.—Fine; very fine; clear and fine.
11.—Overcast; showery; heavy showers at night.
12.—Cloudy but fine; cloudy; clear and fine.

COVENT GARDEN MARKET.—JULY 15.

Our supply is well kept up, and all the soft and bush fruits are in fair request. There have been heavy arrivals from the Continent, and a further supply of West India Peas is announced. Potato trade active.

FRUIT.

Table with columns: s. d., s. d., s. d., s. d. Rows include Apples, Apricots, Cherries, Chestnuts, Currants, Black, Filberts, Peas, Gooseberries, Grapes, Lemons, Melons, Mulberries, Nectarines, Oranges, Peaches, Pears, Pine Apples, Plums, Quinces, Raspberries, Strawberries, Walnuts.

VEGETABLES.

Table with columns: s. d., s. d., s. d., s. d. Rows include Artichokes, Asparagus, Beans, Kidney, Broad, Beet, Broccoli, Brussels Sprouts, Cabbage, Capsicums, Carrots, Cauliflower, Celery, Coleworts, Cucumbers, Pickling, Endive, Spinach, Artichoke, Herbs, Horseradish, Leeks, Lettuce, Mushrooms, Mustard & Cress, Onions, Pickling, Parsley, Parsnips, Peas, Potatoes, Kidney, Radishes, Rhubarb, Savoys, Sea-kale, Shallots, Spinach, Tomatoes, Turnips, Vegetable Marrows.

WEEKLY CALENDAR.

Day of Month.	Day of Week.	JULY 21—27, 1870.	Average Temperature near London.			Rain in last 43 years.	Sun Rises.		Sun Sets.		Moon Rises.		Moon Sets.		Moon's Age.	Clock before Sun.	Day of Year.	
			Day.	Night.	Mean.		m.	h.	m.	h.	m.	h.	m.	h.				
21	Th	Royal Horticultural Society's Oxford Show [closes.]	74.0	59.8	62.4	19	9	4	3	8	57	11	25	11	24	6	6	262
22	F		72.2	51.4	61.8	24	10	4	2	8	no	0	30	2	24	6	8	263
23	S		74.0	51.4	62.7	21*	11	4	0	8	2	0	36	3	25	6	11	264
24	S	6 SUNDAY AFTER TRINITY.	72.6	51.7	62.1	14	12	4	58	7	48	0	49	4	26	6	12	265
25	M	ST. JAMES.	79.9	49.4	61.9	13	14	4	56	7	22	1	42	5	27	6	13	266
26	Tu	Buckingham Horticultural Show.	73.7	50.3	62.0	22	15	4	54	7	4	2	40	6	28	6	14	267
27	W		74.9	59.7	62.8	19	17	4	53	7	57	2	28	7	29	6	14	268

From observations taken near London during the last forty-three years, the average day temperature of the week is 73.6°, and its night temperature 50.8°. The greatest heat was 93°, on the 23rd and 24th, 1863; and the lowest cold 32°, on the 23rd, 1863. The greatest fall of rain was 1.48 inch.

POT ROSES FOR EXHIBITION.



ALL true lovers of floriculture agree in calling the Rose the queen of flowers, the most beautiful of all, the loveliest among the lovely; and rightly so too, for in the varieties of this charming family we have flowers of the most exquisite form, the richest colour, and the most delicious perfume. Take, for instance, a partly expanded blossom of Alphonse Karr, in what flower can we find a closer approach to perfection? its shell-like petals, of a pecu-

liarily soft and pleasing shade of pink, are so beautifully fitted to each other that the fine form of the flowers leaves us nothing to desire. The delicate beauty of Lamarque, the magnificence of Charles Lefebvre, the splendour of the deep rich Eugene Appert, distinct and striking in every feature, its dark elegant foliage being in fine keeping with its velvety-petalled blossoms—these, and a host of others possessing some equally distinct feature, are the kinds to grow; these are the rare gems which command our admiration and rivet more firmly the chains of our "old love."

I have frequently asked myself the question, as I doubt not others have done, when viewing the long ranks of cut blossoms staged in their still formal boxes at a flower show, "Is this the best way in which to exhibit the Rose?" I think not. Cut flowers, but too often without buds or foliage, are subjected to the severest criticism shorn of much of their beauty; but if each variety were to be exhibited not cut from the plant, excepting in the case of novelties, but in the form of a pot plant, what a different appearance would a Rose show present: instead of the long lines of flat staging now used, an effect rivaling that of the Rhododendron Show at South Kensington might be obtained with the greatest ease. From my own experience of Rose culture, I can see no real difficulty in the attainment of an object so desirable, but, on the contrary, very much in its favour. Rose cuttings are easily struck, and the plants grown to a considerable size in a short space of time, as I thoroughly explained in an article published in this Journal last year (vol. xvi, pp. 77, 78), and if an annual batch of cuttings were made, a succession of healthy pot plants, as flourishing and prolific as those planted out, could be maintained. If it be objected, that the culture of Roses in this way for exhibition would make greater demands upon one's time and skill, I think this could very justly be met by pointing to the great utility of such plants for home decoration at all seasons of the year. Moreover, by offering the principal prizes for pot Roses, attention would be drawn to a branch of floriculture but too often neglected, or not understood. Who has not seen the miserable specimens of pot Roses so frequently to be met with in private establishments? Poor sickly-looking objects, which, having undergone their annual forcing, are turned out to rest. To rest! why, I do not believe a healthy Rose is ever at rest. Plant one early in November, lift it and examine its roots at Christmas, and plenty of new rootlets from 1 to 2 inches long will be seen; here is a hint from Nature,

which, if acted upon in the culture of pot Roses, produces the best results. If a Rose, after it has done blooming, immediately begins to grow again, suitable food should certainly be given it; it is therefore necessary, when pot Roses are taken out of the houses into the open air, that all weakly growth should at once be cut clean out, the requisite thinning and shortening given to the stronger wood, the roots shaken free of the old soil, repotted, and the pots plunged to the rim, not behind a wall or shed, but in an open airy position. Plants so treated, and fed occasionally with guano water as they appear to need it, will produce plenty of stout wood clothed with healthy foliage, care being taken to ply the syringe among them all the summer.

Once again I would urge all who really care for Roses to grow them on their own roots, and to train them as I have before advised. No standards can equal the appearance of these glorious pyramids, laden with a multitude of flowers. Nor are their flowers small or puny, although produced in such profusion: the plants are rendered so vigorous by the abundance of stout suckers constantly springing up, and which are trained to whatever part of the plant they may be required, that the lowest tiers of branches present an amount of vigour both in wood growth and bloom quite equal to that of the highest parts.—EDWARD LUCKHURST, *Egerton House Gardens, Kent.*

CULTURE OF THE LARGE-FLOWERED OR SHOW PELARGONIUM.

Among hardy flowers the Rose is justly called the queen, and quite as justly may the large-flowered Pelargonium claim the same exalted title among greenhouse flowers: but how very rarely are plants met with grown as they deserve to be! How often, instead, do we find them crammed among all sorts of plants, and subjected to every variety of treatment: hence we generally find spindly long-drawn specimens, often infested with insects to such a degree as to render them a nuisance, instead of a pleasure. Now, no plant is easier to manage, and the following mode of cultivation will bring them to great excellence. At this place we like them in bloom throughout July, and now (July 8th) the collection of upwards of eighty sorts is in full bloom.

I put the cuttings in about the end of May or first week in June, taking what I can spare or get when staking the specimens. I make them in the usual way, and dibble them in an open south border, give them a good watering when first put in, and then leave them to take care of themselves for three or four weeks. I then pot them in 60 sized pots, and keep them close for a few days until they begin to grow, afterwards I give them a little more air. (The frame used when they are potted the first time should have a little bottom heat.) In a few weeks they will have made good roots, and may be hardened off gradually, and about the end of September or beginning of October potted in the next size of pot, or small 48's. When that is done, the best place for them is a shelf in a greenhouse, and when they have made a fresh leaf or two

zip out the point of the shoots. They should be again shifted, using 6-inch pots, in which size they should bloom the first year.

After they have finished blooming, or begin to look shabby, they should be placed out of doors, and not watered much for a fortnight, when they will be ready to cut down, which operation should be performed with a sharp knife, cutting them down like an Osier stump, and leave them outside until they have broken well, when they should be carefully taken out of the pots, and have every bit of the old soil shaken out, and the ends of the long roots shortened. They should then be potted into their blooming pots, placed in a warm frame or house, and be only sprinkled until growth commences, care being taken not to make them too wet, or the soil will turn sour. They should always have plenty of room and light, and abundance of air whenever it can be given, for that is one of the secrets of success. Always be on the watch for green fly, and as soon as that makes its appearance give them a good tobacco fumigation for two successive nights.

Keep a very low temperature all winter, and nip out the points of long shoots till February, after which time it should not be done. No liquid manure should be given till the flower buds begin to form, when they should have some once a week. When the shoots are long enough they should be thinned if they require it, and tied out to neat straight sticks, which are best made out of plasterers' laths. Watering must be well attended to, for if they are allowed to become very dry they soon suffer, and produce small yellow leaves, and a warm dry temperature is very conducive to filth of all sorts.

The following compost I find answers extremely well:—To four barrowloads of good pasture loam I add one of old Mushroom-dung, one of charcoal broken up fine, one of very old leaf mould, and one of coco-nut fibre refuse, the whole well mixed. I drain the pots with charcoal.

The following varieties are all distinct, first-rate, and would form a good small collection, of course plenty of others might be added:—*Troubadour*, *Progress*, *Charles Turner*, *Heidcock*, *Favourite*, *Viola*, *Hermit*, *Decision*, *Congress*, *Beauty of Windsor*, *King of Trumps*, *Queen of White* (Dobson's), *Rob Roy*, *Emperor*, *Victor*, *Magician*, *Diadem*, *Example*, *Queen of Scots*, *Turban*, *Mary Hoyle*, *Captain John*, *Lord Lyon*, and *Lady of the Lake*.—*RICHARD JAMISON, Gurgave.*

STRAWBERRY CULTURE.

THE crop generally in this district (Lincolnshire) is prolific, and the most prolific of all the varieties under my immediate care is *President*.

In an enumeration of several varieties, with their qualities and characteristics, contributed to the *Journal* two years ago, I unhesitatingly accorded to this variety the place of honour, which it continues to hold worthily. I am inclined to think that it is most at home on a rather light soil. Runners which I have supplied for cultivation in gardens on heavy soil, have, as a rule, been rather unsatisfactory, producing a superabundance of foliage. Those, then, having a light staple of soil to deal with, I advise to grow this variety, and if it serve them as well as it year by year has served me, it will be pronounced worthy of its name.

My plants, now yielding so well, are of the earliest last year's runners, bearing their first crop, and I am confident it is the best they will ever produce. Every year's experience tells me that to insure satisfactory crops of Strawberries on soils of the character of a light vegetable mould, we must secure runners as early as possible, treat them well throughout the season, and depend on their first efforts for the best yield. If by adversity of weather or any other kind of adversity, plants cannot be secured sufficiently early for permanent planting in July, after early Potatoes, it is good practice, taking into consideration the economy of the general cropping of the garden, to wait for very late runners—small ones—and prick them in nursery beds quite at the end of September, or in October. For the convenience of hoeing, &c., the rows should not be nearer together than 9 inches, and the plants in the rows may be 4 or 5 inches apart. Here let them remain until an early crop is off in spring—say the crop of early Potatoes, which I, as a rule, like them to follow, but cannot always make them do so—this year for instance. I can see nothing clearer than to plant after early Cabbage, but it goes rather against the grain, and I can only keep a smooth surface by reflecting on a mixture I have in reserve, composed mainly of old Strawberry plants and clearings of the beds last year, kept in a separate rot heap. This,

with a lot of old plants in their last stage of existence, and which will be cleared off and put at once green into the trenches, will act both as a sedative and stimulant, and animal and vegetable—that is, myself and plants, will be mutually benefited.

This plan of manuring Strawberries with Strawberries is as good in practice as it is in theory, and was the secret of success of an amateur cultivator, a clergyman in this neighbourhood, who for years produced off the same ground magnificent crops of fruit by this system of manuring. I have also tried it myself, and have not found it wanting—in fact, it is the root of the matter over which at present my President presides so worthily.

Plants treated on the plan described, other things being favourable to their well-being, are sure to bear splendidly—quite as well as, perhaps better than, plants from early runners encouraged and planted at once in the fruiting-bed for the next season's bearing. But why not plant out sooner? some may ask. Why wait until the end of June, or till July? Simply this, by planting good plants of *Strawbericia* in March or April, as is frequently done, you insure good crops the following season, but by waiting two or three months longer you insure not only a good crop of fruit, but also a good crop of early Potatoes, off the same ground. Putting this against the planting of fine early runners in the permanent beds at once, a season is certainly lost; but when once fairly in the system the loss dwindles away, and the only disadvantage it has, looked at in the general economy of cropping, is the bit of ground occupied as nursery beds for the half year beginning in October. The principal point to be attended to, is the planting runners small and late, or they will be drawn and injured by remaining in the nursery bed so long.

Strawberries on soil of this nature do not, as a rule, give more than two fine crops. I sometimes let them bear three, but the last has never yet satisfied me. I do not "bury cart-loads of manure;" I bury the refuse above mentioned, and then point in the surface 2 or 3 inches of yellow loam, if I can obtain it mixed with old hotbed manure, just to give the plants a start; but the principal amount of manure is put on not in the ground. After planting, which is not done until the ground is well firmed to give it "body," the best substitute for "heart," the whole surface is well covered, and kept covered. The surface of the ground is never bare summer nor winter, and is not disturbed by fork nor spade. The manure used for this purpose is not decayed, but is in a comparatively green state, and by the washing of rains, and exposure to the weather nothing is seen but strawy material, clean and close, for the fruit to lie on, no further attention being required in this respect.

It is to this surface dressing arresting evaporation, that I mainly attribute success in Strawberry culture on light soils. Undoubtedly, on some soils, Strawberries will yield productive crops for four or five years, or by carefully thinning the crowns even ten years; but for soil of the character I deal with in this paper, the system of long-standing plantations breaks down; at least, this is my experience. For such soils plant frequently, mulch, and mulch continually, ever bearing in mind Mr. Radclyffe's advice, always sound, Do not pack the mulching closely round the hearts to blanch them, or farewell Strawberries.—*J. W.*

EARLY VERSUS LATE PLANTING RIBBON BORDERS.

(Concluded from page 3.)

In continuation of the above subject, although I praise early planting, it is, as I have already remarked, often from necessity rather than choice. Forcing houses and pits become overcrowded, and the other means of sheltering the plants being insufficient, we are often reluctantly compelled to thin them out; for, supposing the plants in single pots were only wanted to plant the two borders described in my former article, and that twenty rows of plants, each about 200 yards in length, were wanted, these alone would make upwards of two miles and a quarter of single row, too many for the accommodation we have, and as we have other beds and borders as well, an easy way of accomplishing the object has to be adopted.

The management of *Calceolarias* is easy enough; cuttings put very thickly into a cold pit in October or November are thinned out very often in March, and the plants left are quite large enough for turning out by the end of April; if the ground is in tolerable condition, and the site not too much exposed to east winds, they will often succeed well. At all events, they

are about the hardiest of bedding plants, and in our case were transplanted direct with balls from the cold pit to the borders, some before Easter Sunday, and some the week after, the dry weather at the time interrupting the operation. Next came *Verbena pulchella*, a tolerably hardy kind, but still one that likes warm weather better than cold, and I believe a better result would have followed had we waited a fortnight, but the plants had become stunted by confinement in a crowded state in the cutting pans and boxes, and required more room; so, trusting to the weather, we planted them out at once on April 30th, excepting a few not sufficiently struck at the time, which were put out a fortnight afterwards. Their progress was, of course, slow for a time—nay, I am not sure that they did not retrograde; still, none of them died, or but very few, and they now (June 9th) promise soon to occupy their allotted space.

I now come to the *Pelargonium*. The balk of these are wintered in wooden boxes 2 feet long by 1 foot wide and 3 inches deep for young plants, and 1 or 2 inches deep for older taken-up plants. Now it often happens that these small plants become very much drawn by the middle of April, so that a fresh lot of cuttings is often taken off; and in some seasons we have shaken them out of the boxes, tied a little moss and soil round hundreds of them, and placed them on a slight hotbed or in a sheltered position for two or three weeks before planting; but this season circumstances prevented our doing so, and there was no alternative but planting them out directly from the cutting box. The question then arose, Was it prudent to do that work early, or to wait till others were planting out their potted plants? This was the way to put the matter, and not, Which is the proper time to plant in general? Observe, I am not advocating early planting where there exist the means of keeping the plants in a suitable condition till a more genial season arrive, yet the results of early planting are not always so discouraging as to render it entirely unworthy of support. I remember the best bed of *Pelargoniums* I had one year was planted in April, but the plants were covered with Laurel boughs for a time, a practice I have often adopted with early planted-out subjects, but which I had not the opportunity of practising this year. On the other hand, one season we suffered much by a frost late in May, I think the 23rd or 24th, when a number of plants of *Perilla* were quite killed, and the *Pelargoniums* and other bedding plants much hurt, while those not planted till after that time succeeded much better. The air and plants at the time of that frost were both moist, hence the injury. The thermometer on the morning of May 23rd was lower than I have ever registered it in May during the last twenty years, being 27°, and that for many hours too; but the air was dry, and the morning dull, so that the injury done was not so great as, from the severity of the frost, might be supposed. In other frosts during the same month, the shoots of Oak, Ash, and other trees were blackened.

In connection with early planting, the state of the ground must be set down as an essential condition of success, and it has generally been one of our difficulties, as the soil of our flower beds, though well adapted for sustaining a long summer's growth, is not the best to work early in the season, for it is what is termed a stubborn soil, and in some seasons is much worse than in others. This year has been one of the best, while 1869 was bad. So stiff is the ground sometimes that we are obliged to obtain some fine soil from elsewhere to plant in, or rather to cover the roots of the little plants assigned to such hard lumps. I well remember the expression of a gardener of high standing who visited me one season when the soil was of the coarsest description, and the men were fixing down the shoots of *Verbenas*, not with pegs, hair-pins, or strips of matting, but with clods of the sun-dried earth, about the size of a cricket ball, obtained on the spot in any quantity. Such rude treatment amused my friend, who, doubtless, expected more from his own neatly manipulated beds, but a genial rain setting in soon after melted down these weights, to the advantage of the plants I believe. A rather long continuance of dry weather followed, and then it came to my turn to visit my friend's garden, and the lough was turned against him; his smooth ashy-looking soil had not been able, with the aid of the water of a canal that flowed past it, to support his *Verbenas* in health, while mine were all that could be desired. However, a certain degree of pulverisation is necessary at planting, and I am in the habit of looking as much at the state of the ground as at that of the atmosphere; nevertheless, it must be acknowledged, that when the two are combined the best result follows. The condition of the plants,

however, has a great influence in hastening or delaying planting out, for to wait till a plant falls into bad health from crowding or lack of nourishment at the root, is often equivalent to waiting till disease sets in. *Calceolarias* are especially liable to suffer from this cause. The Variegated and Ivy-leaved *Pelargoniums* appear to bear such treatment as well as any plant, but it cannot be said that they are improved by it.

Although I have mentioned some subjects which may be planted out early without dying, yet there are others it would not be prudent to try. *Heliotropes*, *Tropaeolus*, *Ageratums*, and even *Labellias* are less hardy than the plants I have named; while *Alternantheras*, *C. Russes*, *Caster Oil plants*, and the like, are still in me delicate. On the other hand, *Petunias* are tolerably hardy, so, too, are *Geraniums*, *Narcemburgias*, and *Centaureas*. The last named, however, has suffered more with me this past winter than it has ever done before.

I would now invite the opinions of others on the subject, whose practice, if recorded, may do much either to condemn early planting, or to support it as not being so detrimental as it is supposed to be; for, be it remembered, if it can be proved that a plant turned out, say on the 25th of April, is as good on the 25th of June as one turned out on the 25th of May, the advantages of getting the first planted one out of the way are such as to render the earlier planting preferable, the state of the respective plants at turning-out time, and other conditions, being the same. But I have already said enough, and I expect our worthy mentor, "R. F.," will find many and cogent reasons for delaying his planting so late, each of them important to the planter. Nevertheless, I advocate early planting where circumstances, as here, almost compel its adoption.—J. ROBINSON.

THE STRAWBERRY SEASON.

I HEAR on all sides, "I have no Strawberries!" Here they never were finer nor more plentiful. I like a West Indian summer for fruits and flowers. All that is wanted is sufficiency of manure, and water equal, in some measure, to excessive evaporation. I have had magnificent crops of Rivers's *Eliza*, *Cockscomb*, *Wonderful*, *Dr. Hogg*, and *Mr. Radclyffe*, of which the last-named is the best in flavour. In constitution, setting its fruits, and colour, it is superior to the *British Queen*; in other respects, and especially as regards flesh, flavour, and foliage, it is identical. I had some very fine early and highly-flavoured berries of *Foote's*, which should be more known. I think *Mr. Radclyffe* and *Dr. Hogg*—the two finest in the Queen line—succeed best by early annual (say July 1st) plantation. I took on July 5th a noble lot of Strawberries, consisting of *Mr. Radclyffe*, *Dr. Hogg*, *Wonderful*, and *Cockscomb*, to *Sir William Marriott's* cricket-mead—(a match between his eleven and eleven of the 7th Fusiliers, quartered at Donchester. *Sir W. Marriott* and *Capt. Glen* measured the largest *Cockscomb* with tape marked with the inches, and it was 11 inches in circumference. I enclose *Sir William's* letter for the Editors' perusal. This I do, because people who grow Strawberries the size of "snags," cannot still believe that I grew one last year 12 inches round. They do not appear to have measured the largest of the *Dr. Hogg* Strawberries, which, I believe, ranged from 7 to 9 inches. It is a noble Strawberry, but not equal to *Mr. Radclyffe* in flesh, flavour, and colour. I should, however, be inclined to recommend it to careless people rather than *Mr. Radclyffe*. They are both easy to cultivate, and neither are particular as to soil.

The *British Queen* hates chalk, but these, too, I have grown successfully in the chalky soil of *Itashton* and in the sandy loam of *Oxford*. The *Bicton Pine* and *Frogmore Pine* are not in crop this year. The *Alpines* have been most abundant. *Galanda* is a splendid red *Alpine*. I wonder people do not grow *Alpines*. With a little sugar, I think they are the finest flavoured of all Strawberries.

Last year my runners of all sorts were planted July 1st. This year I made my new beds July 4th, 5th, and 6th. Early establishment is a great matter, also firm ground. I plant after Cabbages, which are kept constantly loe'd, and I do not dig the ground at all. Holes, 19 inches apart each way, are scooped out, and filled with liquid manure, and in due time the runners are put in with loam and decayed manure sifted fine, and trodden in as hard as it is possible to do. The runners are then kept sufficiently watered. The hotter the weather is the better it is for the new plantation. The July plants of last year are now larger than some people's three-year-old plants.

Two years, except in rich clays, is, I think, long enough for many sorts to stand.

The only novelties on trial here were Dr. Roden's two seedlings, the Duke of Edinburgh and Early Prolific, and Mr. Segrave's (of Marlow) Royalty. The Duke is a superior Strawberry for form, flesh, and flavour, but here it is too dwarf in growth. The Early Prolific is a better grower, and has a pleasant flavour. Royalty appears to be the same as the Scarlet Pine, or Rival Queen, in foliage, form, flesh, flavour, habit, and appearance. It has the same fault—namely, it is a precarious setter, but of a most rich and excellent flavour. I should not have got rid of the Scarlet Pine or Rival Queen—in the same line—had they been good setters. I cannot, hereafter, try Strawberry plants or Potatoes for anyone.—W. F. RABCLIFFE, *Oxford Fitzpines*.

THE ROYAL HORTICULTURAL SOCIETY'S OXFORD SHOW.

Oxford is a city with a long history—a longer history than one cares to recount, for it goes back a thousand years and becomes lost in the mist of time; for nearly that period, if not quite, there science, and art, and literature have flourished, and the disciples which its many colleges have sent forth have carried the stored-up learning of past generations and their own into the wide world. Who, then, can tell its history? Who the influence it has had on the things that be? Nor is it without a history in another sense—war has been no infrequent visitant at its gates—and alas! while we write these words war again is about to deform the fair face of Europe, and such a war, and between such nations! *Terruit ubi, terruit gentes*, that, perhaps, is the reason that when we left Oxford yesterday neither Horticulture nor Agriculture was so well countenanced as we should have wished. Still, the Show which commenced on Tuesday, and is to close on Friday next, is one well worthy of special attention, and of special encouragement also. It is worthy of attention even by the frequenters of the London shows from its own merits as a show, and as an indication of the state of horticulture in the provinces; it is worthy of attention by those in the provinces, for it brings to their doors what many would never see without a long journey, perhaps never see at all; and it is deserving of encouragement both by town and country for this reason, and because it benefits both; and more—still more, it brings men from all parts of the land into social contact, cements old friendships, and forms new. It is more especially at these country shows the gentlemen and the gardener come together, they converse with each other, and they learn from each other; each gains in information, and each can better appreciate the other. Thus the strong wall which is built up between man and man, and class and class, is breached, and we believe—we feel sure—to the benefit of the gardener's art, to the benefit of the community at large. The details of the Show, which is held in the grounds of the Radcliffe Observatory, and which, with the combined Show of the Royal Oxfordshire Horticultural Society, occupies eight large tents, will be found in the following reports. To these we purpose giving some additions next week, together with a notice of the Congress, which commenced yesterday at too late an hour for us to enter into details. So far the weather has been everything that could be desired, were it not for the drawback of a tropical temperature. Let us hope that the results in every sense will be equally favourable.

MIXED GROUPS OF FLOWERING AND FINE-FOLIAGED PLANTS.—For these prizes of £25 and £15 respectively were offered by the Royal Horticultural and Royal Oxfordshire Societies. The former is taken by Mr. Baines, gardener to H. Micholls, Esq., Southgate House, Middlesex, who is first with a remarkably fine collection, consisting of *Dipladenia crassinoda*, very well bloomed; *Dipladenia amabilis*, the large flowers of which are in beautiful condition; a splendid specimen of *Erica obtata*, 5 feet in diameter; *Ixora coccinea*, loaded with magnificent heads of its brilliant scarlet flowers; *Allamanda nobilis*, very fine; an unnamed very free-flowering *Allamanda*; *Ixora aurantiaca*; *Bongainvillea glabra*, forming a charming mass of rosy bracts; *Phorocoma prolifera* Barnesii, in good bloom, but not large; and an excellent plant of *Erica amula*. Of fine-foliaged plants Mr. Baines has *Croton variegatum*, with its colour most beautifully developed; of *Gleichenia rupestris* a large specimen extremely beautiful and delightfully fresh; *Theophrasta imperialis*, very fine; *Dasyliroa acrobichum*; a remarkably fine specimen of *Phenacophorum sechellarum*; a very large plant of the equally beautiful and not dissimilar *Verschaffeltia splendida*; *Dicksonia antarctica*; *Croton angustifolium*, large, and with the golden variegation fully developed; *Yucca variegata*; and a good specimen of *Cordylina indivisa*. Mrs. E. Cole and

Sons, withington, Manchester, are second with a very good collection, consisting of *Dipladenia crassinoda*, *Allamanda cathartica*, *Genetyllis tulipifera*, *Aphelaxis humilis grandiflora*, *Dipladenia acuminata*, *Phorocoma prolifera* Barnesii, a very large bush of *Erica Cavendishii*, *Aphelaxis macrantha rosea*, an excellent *Kalosanthes punicea*, a rather poor specimen of *Erica Parmentieriana rosea*; while of fine-foliaged plants the collection contains excellent specimens of *Croton variegatum*, *Dicksonia antarctica*, variegated *Yucca*, *Livistonia borbonica*, *Croton angustifolium*, and *Dasyliroa acrobichum*.

STOVE AND GREENHOUSE PLANTS.—Mrs. Cole & Sons also send the best collection of nine stove and greenhouse plants in flower. This consists of excellent specimens of *Ixora coccinea*, *Dipladenia amabilis* in fine bloom, *Aphelaxis macrantha purpurea*, *Kalosanthes punicea*, *Dipladenia crassinoda*, *Gomphobium polymorphum splendens*, and fair examples of *Ixora javanica*, *Allamanda grandiflora*, *Dipladenia crassinoda*, and *Phorocoma prolifera* Barnesii. The second prize goes to Mr. F. Perkins, Leamington, who has fine plants of the large-flowered *Allamanda Hendersoni*, *Stalicia imbricata*, *Vinea rosea*, and others of less note. Messrs. Bell & Thorpe also show in this class, and have a very good plant of *Dipladenia amabilis*, the yellow-flowered *Cassia corymbosa*, and well-bloomed *Stalicias*. The special prize offered by F. J. Morrell, Esq., for the best specimen stove plant in flower is taken by Mr. Baines, gardener to H. Micholls, Esq., with a specimen of *Allamanda cathartica*, forming a balloon 5 feet by at least 2½ feet across; and the second prize, given by the same gentleman, goes to Messrs. Standish & Co., of the Royal Nurseries, Asea, for the third prize is awarded to the singular-looking *Aristoebelia ornithocephala*, from Mr. F. Perkins, nurseryman, Leamington. Messrs. Gill's prizes for the best and second best specimen greenhouse plants go to Mr. Baines for a very fine plant of *Erica Fairriana*, 4 feet in diameter; and the second to Mr. A. Wright, gardener to C. H. Crompton Roberts, Esq., Regent's Park, London, for a very good specimen, though rather past its best, of *Kalosanthes Madame Celeste* Wianans. In the local class for six stove or greenhouse plants, Mr. G. Harris, who is first, has a very well-grown *Clerodendron Thomsonae*, but its bloom over, a very good *Rondeletia* is also exhibited, and *Asclepias currasavica*, a showy plant, but seldom seen, and in this instance straggling; the others do not require notice. The second prize goes to Mr. J. Walker for a good pot of *Lilium eximium*, *Caladiums*, and *Colasenas*. The "Florist and Pomologist" prize for stove and greenhouse plants was awarded to Messrs. Bell & Thorpe, Stratford-on-Avon, for a collection in which there is *Abutilon Thompsoni* with a few flowers, two *Petunias*, a *Lantana*, *Diplacus grandiflorus* in good bloom, and *Lilium auratum*.

ORCHIDS.—But few are shown; there is only one collection in the amateurs' class for six, which comes from Mr. A. Wright, gardener to C. H. Crompton Roberts, Esq., Regent's Park, who has *Oncidium Schieperianum*, *Lycastes*, *Acridas*, a *Cattleya*, and other plants not remarkable. Mr. Williams takes the corresponding position in the nurserymen's class with *Anguloa Clowesii*, *Dendrobium Parishii*, showy; *Vanda suavis*, *Acridas quinquevulvatum*, *Cypripedium superbum*, fine, and a very good pan of *Cypripedium barbatum superbum*. Messrs. Rolleston & Sons are second with a fine specimen of *Acridas odoratum majus*, with about two dozen fine racemes, *Acridas Lobii* with half a dozen, *Epidendrum vitellinum majus*, fine, a good pan of *Cypripedium barbatum majus*, and *Odontoglossum hastilabium*.

HERBACEOUS.—The silver cup, offered by W. Wootten-Wootten, Esq., goes to Mrs. E. Cole & Sons for excellent plants of *Erica Parmentieriana rosea*, *ventricosa magnifica*, *feruinea superba*, large and fine, *venosa*, a well-grown *emula*, and good but smaller specimens of other kinds. The second prize, offered by Lord Valentia, goes to Mr. A. Wright, gardener to C. H. Crompton Roberts, Esq., for a large specimen of *ventricosa Bothwelliana* in profuse bloom, the showy scarlet *cerinthoides variegata*, and good examples, though not large, of *tricolor* Wilsoni and *Fairriana*. The special prize, offered by the Warden of New College for six, is taken by Mrs. E. Cole & Sons with good plants of *venosa*, *ventricosa magnifica*, *gemmifera elegans*, with others less remarkable. Messrs. Grindley, Hughes, and Dewe's prize is taken by Mr. A. Wright with an evenly-grown lot of plants, though rather small.

FINE-FOLIAGED PLANTS.—These make a good display, although the specimens are not remarkable for great size. Mr. Johnson, gardener to the Marquis of Ailesbury, Savernake, takes the first position in the amateurs' class for nine, with very good specimens of *Alcaecia metallica*, a fine *Caladium Belleyeii*, *Sansevieria angolensis*, *Pandanus elegantissimus*, *Croton angustifolium*, a fine healthy plant of *Spherozygia latifolia*, *Alcaecia macrorhiza variegata* with its leaves three-fourths white, and a very good specimen of *Croton variegatum*. The second prize goes to Mr. A. Wright, who, among other plants, has the extremely graceful *Cupania filicifolia*, *Demonorops plumosus*, an elegant *Palm*, and other good specimens. The best nine in the nurserymen's class come from Mr. Williams, who has a splendid plant of *Alcaecia metallica* in perfect condition, a fine *Phenacophorum sechellarum*, *Dasyliroa plumosum*, *Cycas revoluta*, very fine; a large and very pretty *Cordylina indivisa*, and a fine *Yucca quadricolor*.

PALMS.—These are not very numerously shown. Mr. B. S. Williams is first with noble plants of *Phenacophorum sechellarum*, *Livistonia Jenkinsii*, and *Verschaffeltia splendida*, the others being fine specimens of *Chamerope humilis*, *Areca lutescens*, and *Thrinax elegans*.

Messrs. Rollisson are second with a pretty collection, prominent in which are fine plants of *Chamaecyparis erecta*, *Thrinax argentea*, and others.

CORYLIANS AND DRACENAS.—Here Mr. Williams, of Holloway, takes the lead with very fine plants of *Dracena atrosanguinea*, *D. lineata*, *D. anastralis*, not a large but a beautiful young specimen, and *D. umbraeflora*. Messrs. Bell & Thorpe are second with very small specimens, and Mr. S. Daniels, gardener to the Rev. S. R. Keene, Syoncombe Park, third.

FERNS.—Of these there is not so large a show as on some former occasions, but the want is more than made up for by the quality of those shown. Mr. Williams, of Holloway, is first for nine with large and fine examples, with fronds of the greatest freshness, consisting of *Cyathea dealbata*, *Todea africana*, two good *Gleichenias*, *Cibotium Schiedei furcans*, *Dicksonia squarrosa*, *Davallia dissecta*, very beautiful, *Dicksonia antarctica*, and a particularly fine and very wide-spreading *Cyathea princeps*. Messrs. Bell & Thorpe, Paddock Nursery, Stratford-on-Avon, are second with a very good Bird-nest Fern, and small well-grown specimens of *Cibotium*, *Alsophilas*, *Blechnum corceadense*, &c. Mr. J. J. Chater is third. In the amateurs' class for six, Mr. Baines takes the first position for a specimen of *Gleichenia splechnae* most beautifully furnished, and measuring nearly 5 feet in diameter; good examples of *Cyathea dealbata* and *medullans*, *Davallia bullata*, fine; *Davallia tenuifolia*, and a fine pan of *Todea superba*. The second prize goes to J. Mapplebeck, Esq., Woodfield, Moseley, Birmingham. The first of the special prizes given by H. Grisewood, Esq., was awarded to Mr. Wright, gardener to C. H. Crompton Roberts, Esq., Regent's Park, for a collection containing a beautiful *Adiantum fadyense*, *A. emarginatum*, *Cibotium Schiedei*, *Lomaria gibba*, *Dicksonia antarctica*, and *Cyathea princeps*. Messrs. Bell & Thorpe are second. A first-class certificate was awarded to Messrs. Wood & Ingram for a new variety of *Lomaria nuda*.

The best pair of Tree Ferns are from Mr. Williams—viz., *Dicksonia antarctica*, and *Cyathea Smithii* about 12 feet high; the second best come from Mr. C. Walton, Cowley Road, Walton; and are a well-grown pair of considerably less size, round the trunks of which is trained white variegated Ivy.

BRITISH FERNS.—Of these, J. E. Mapplebeck, Esq., Woodfield, Moseley, Birmingham, has a well-grown collection of twelve, in which are very good specimens of *Scelopendrium vulgare crispum*, *Trichomanes radicans*, *Athyrium Filix-foemina Priebradii*, and others. For this a second prize is awarded. E. J. Lowe, Esq., Highfield House, Notts, is third with a pretty collection, in which we particularly noticed *Osmunda regalis cristata minor*, *Scelopendrium vulgare optatum*, *Polystichum angulare decompositum*, and *A. F. f. plumosum Monkmani*. Mr. Caswell, St. John's Terrace, Oxford, is awarded the first prize. The local exhibitions of Ferns from Messrs. Chapman, Callam, and Castell in the class for twelve, and Messrs. Belcher, Howlett, and Walker, are very good. The best twelve in the nurserymen's class are from Messrs. Ivory, of Dorking, and consist of *Athyrium F. f. trifidum*, lanceolatum, *Girdlestonei*, *ramo-cristatum*, *formosum-cristatum*, *Fieldie*, *plumosum*, *Polystichum angulare cristatum*, *acuto-dissectum*, *Lastrea Filix-mas cristata*, *Iveryana*, and *Osmunda regalis cristata*. The Right Hon. E. Carlwell's first prize for twenty British Ferns is also taken by Messrs. Ivory & Son, of Dorking, with *Athyrium F. f. Granite*, *formosum cristatum*, *grandiceps*, *Girdlestonei*, *conioideis*, *plumosum Axminster var.*, *plumosum*, *fissidens*, *Vernonia*, *pulchellum*, *corymbiferum*, *Osmunda regalis cristata*, *Polystichum angulare plumosum*, *incisum*, *conspicuosum*, *Lastrea Filix-mas Pindleri*, *cristata Iveryana*, *A. F. f. Fieldie lanceifolium*, and *Trichomanes radicans*. The second and third are awarded to J. E. Mapplebeck, Esq., and E. J. Lowe, Esq.

In the very extensive collection of British Ferns shown by E. J. Lowe, Esq., of Highfield House, Nottingham, the following received first-class certificates—viz., *Asplenium marinum ochmibianum*, *Polystichum angulare monogones*, *Lastrea F. mas acceptum*, *Athyrium F. f. strobiliferum*, *A. F. f. exemplum*, *Scelopendrium vulgare corculum*, *S. v. kraspedon*, *S. v. krosson*, *S. v. marginis*, *S. v. perikallion*, *S. v. stephanoides*, *S. v. poluskiston*, *S. v. semnon*. J. E. Mapplebeck, Esq., also received several first-class certificates for new forms—viz., *Athyrium F. f. defecto-sectum*, *A. F. f. caput-Meduse*, *A. F. f. Jonesii*, *A. F. f. densissimum*, *A. F. f. treccillans*, *A. F. f. Craigii splendens*, *A. F. f. flabelliforme cristatum*, *A. F. f. Gilsoniae furcans*, *A. F. f. conicum*, and *Polystichum angulare brachiato-cristatum Smithii*.

PELARGONIUMS.—For six double-flowered Pelargoniums prizes were given by the Rev. W. Vernon Harcourt. The first of these was taken by Mr. Bragg with *Gloire de Nancy*, *Madame Lemoine*, *Capitaine L'Hermite*, *Victor Lemoine*, and *Marie Lemoine*. The plants are not large, but on the whole well bloomed. The second prize was awarded to Messrs. Bell & Thorpe for coarse-looking plants. Of double-flowered Pelargoniums shown in Class 18, Mr. Perkins, of Leamington, has *Marie Lemoine*, *Madame Lemoine*, and *Wilhelm Pützer* in fine bloom, the first with a profusion of trusses. Messrs. Downie and Co., of Stanstead Park, are second with excellent specimens; Messrs. Bell & Thorpe third with immense plants, but with few flowers in comparison to the quantity of foliage; and Mr. House, of Peterborough, is fourth.

The best stand of twelve varieties of double-flowered Pelargoniums, five trusses of each, comes from Mr. Perkins, of Leamington, and

consists of *Triomphe*, *Madame Rose Charmeux*, *Andrew Henderson*, *Madame Michel Buckner*, *Marie Lemoine*, *Victor*, *Triomphe de Thameuil*, *Capitaine L'Hermite*, *Wilhelm Pützer*, *Victor Lemoine*, *Madame Lemoine*, *Gloire de Nancy*. The second prize went to Messrs. Kelway & Son, of Langport, and the third to Messrs. Carter and Co.

The best six variegated Zonal Pelargoniums come from Mr. Turner, and consist of very well-grown specimens of the following white-edge kinds—viz., *Compactum*, *Jane*, *May Queen*, *Albion Cliffs*, *Miss Bridges*, and *Princess Alexandra*. J. E. Mapplebeck, Esq., comes second with plants 2 feet across, well-clothed with foliage, and Mr. Perkins, of Leamington, third. Mr. Welsh, gardener to D. Rutter, Esq., Parkfield House, Hillingdon, is first in class 18, for six Tricolor Pelargoniums, with excellent plants, both in growth and leaf-colouring, of *Lucy Grieve*, *Sophia Casarek*, *Comtesse de Tyronnel*, *Lady Callam*, and *Sophia Damaresque*. Mr. Stevens, of Ealing, is second, and Mr. Turner third, the latter with small plants of which *Achievement* is noticeable for the brightness of its zone, while Sir Robert Napier is equally conspicuous for its dark zone. Another third prize was awarded to Mr. Tomkins, Spark Hill, Birmingham. The special prizes given by Sir A. W. Peyton, Bart., go to Mr. Welsh for compact well-grown plants of Mrs. Turner, *Imperatrice Eugénie*, *Sophia Casarek*, *Lady Callam*, *Glen Eyre Beauty*, and *Edwinia Fitzpatrick*. Mr. Stevens, who is second, has also good plants. The best four Zonal Pelargoniums (not variegated) shown in Class 89, in which special prizes are offered, come from Messrs. Bell & Thorpe, and consist of *Eleanor*, *Gloire of Waltham*, *Mr. William Paul*, and *Lady Constance Grosvenor*, and are well-grown and bloomed plants of 2½ to 3 feet in diameter. The others are not remarkable. The best six in Class 15 also come from Messrs. Bell & Thorpe, and are well-grown and bloomed, and include a good scarlet seedling called *John Thorpe*, *Eleanor*, *Lord Derby*, and *Fairy Princess*. Mr. Walker of Thame, is second, the best being a very fine plant of *Amy Hogg*. Mr. J. Chater, of Cambridge, is third.

Cut trusses of Zonal Pelargoniums are also shown. In the class for three trusses of twelve varieties there are several excellent stands, especially the winning ones from Mr. Walker, of Thame, Mr. C. J. Perry, and Mr. Minchin, of Hook Norton.

PELVAS present a gay appearance, especially the single-flowering sorts from Messrs. Bell & Thorpe, who are first for six. The special prize offered by the Warden of Wadham College for double-flowering kinds is taken by Mr. Harris, Headington Hill, with very well-grown plants trained on flat wire trellises 3 feet in diameter.

SUCCULENTS.—Of these Mr. Williams, of Holloway, has an excellent twelve, for which he takes the first prize. Among them are *Agave Verschaffelti*, *Dickia Verschaffelti*, very handsome; *Agave Schidigeri*, *Agave filifera major*, another thready-leaved kind; *Echinocactus Pfeifferi*, *Aloe socotrina*, and *Rhipidolobum plicatile*. Mr. Ware, Hale Farm Nurseries, Tottenham, is second with a collection mainly consisting of *Echeverias* and *Sempervivums*, and Messrs. Bell & Thorpe third. In this is the singular-looking cup-shaped *Greenovia aurea*; there is also a nice pan of *Sempervivum arachnoideis*. Mr. J. Chater, of Cambridge, also exhibits, and Mr. Ware has a numerous and interesting miscellaneous collection.

ROSES make a grand display, the stands of cut blooms occupying the whole of one side of the long fruit tent and part of the other side. In forty-eight single trusses Mr. J. Cranston is first with, among others, beautiful examples of *La France*, *La Boule d'Or*, *Senateur Vaisse*, *Niphotos*, *Sophia Coquerelle*, *Maréchal Niel*, *Gloire de Dijon*, &c. Mr. Turner is second with very fine trusses, and equal third prizes go to Messrs. Paul & Son and Mr. Cant, of Colechester, while Messrs. Lee, of Hammersmith, are fourth. In the amateurs' class for the same number Mr. C. J. Perry, of Castle Bromwich, takes the first position. Mr. Moore, gardener to T. Lloyd, Esq., Warwick, being second, and Mr. Johnson, Uxbridge, third. In the amateurs' class for twenty-four Mr. Moore is first, Mr. Johnson, Uxbridge, second, and Mr. C. J. Perry third. For twelve the principal prizes go to Mr. Cavell, Walton Manor, and Mr. Tranter, Upper Assenden; while for six Mr. Tranter takes the lead. For twelve Roses sent out in 1867 Mr. Turner is first with *Elie Morel*, *François Fontaine*, *Baroness de Rothschild*, *Deviennes Laury*, *La France*, *Miss Poole*, *Duke of Edinburgh*, *Marie Girod*, *Edward Morren*, *Nardy Frères*, and *Comte de Hainault*. Messrs. Paul & Son are second, and Mr. Cant third. Prizes were offered by J. Thomson, Esq., for nine yellow Roses, and were carried off by Messrs. Paul & Son, Mr. Turner, and Mr. Cranston. Among these are magnificent examples of *Maréchal Niel*, *Gloire de Dijon*, *Cloth of Gold*, *Madame Falcot*, and *Madame Margottin*. The Rev. J. Dry's special prize for the best six Roses sent out in 1868-9-70 is taken by Mr. Turner with *Reine Blanche*, *Duke of Edinburgh*, *Henri Ledechaux*, *Montplaisir*, *Edward Morren*, and *Lord Napier*. Mr. Turner was also successful in winning the Oxford Rose Society's first prize for a collection of varieties sent out in 1867-8-9 or 1870, the second prize going to Mr. Cant. Mr. G. Prince's prize for the best twenty-four blooms of one variety, was awarded to Mr. Chard for *Souvenir d'un Ami*. The prize given by the Misses Turner for the best three blooms of any variety is taken by Mr. Cant with *Pierre Notting*, remarkably fine. Messrs. Lee exhibit, not for competition, a stand containing, besides beautiful blooms of *Maréchal Niel*, others of *Clemence Raoux*, very attractive by its peculiar colouring, as well as of *Edward Morren*.

MISCELLANEOUS.—Among miscellaneous collections of plants, that of Messrs. Veitch is especially noticeable, not only from the excellent effect of the arrangement, but still more from the value, rarity, and beauty of the plants of which it is composed. The *Nepenthes* suspended in front add much to the grace of the whole by their large pitchers. The plants forming this collection are so numerous that we can only specify a few of the most remarkable. These are *Begonia Cheloni*, *Sedum*, and *Veitchii*, the latter with large orange scarlet flowers, and the plant, moreover, is said to be hardy; *Dendrobium Bensonianum*, the new *Dracaena* which we have lately noticed, *Croton*, *Araucaria Rulei* and elegant *Maranta tubispachia*, a fine specimen of *Anthurium Scherzerianum*, *Dicffenbachia Bowmannii*, *Odontoglossum Laurenciaum*, *Lepidopteris superba*, and *Cypripedium Stouci*. For this collection the first prize was awarded.

The second prize was awarded to Mr. Williams, of Holloway, who had also a rich well-arranged collection, most conspicuous in which is the beautiful *Cochlostema Jacobianum*, beautiful pans of *Hymenophyllum demissum* and *Todea superba*, new *Dracaena*, the single leaf of *Begonia discolor*, *Cypripedium Stouci*, several *Palms*, and many interesting plants.

Messrs. Lee, of Baunsmersmith, have also a large collection consisting of *Heaths*, *Palms*, and several *Ferns*, among the latter of which are the handsome *Adiantum Sancte-Catherine*, *Adiantum lunulatum*, and *A. capillus-Veneris magnificum*, a fine variety and harder than *A. farleyense* to which it bears considerable resemblance. *Araucaria elegans* and *Rulei*, and the showy scarlet and black *Climacanthus Dampieri* are among the remainder. Mr. Ware, of Tottenham, also has an extra prize for one of his charming collections of hardy flowering and ornamental-leaved plants. Messrs. Hollison, of Tooting, have a third prize for a very effective group of *Palms*, new *Dracaenas*, *Pandanus*, *Ferns*, *Caladiums*, *Heaths*, and *Orchids*. *Chamaedorea gramineifolia* is a very handsome *Palm*, small specimens of which are very elegant for table decoration.

Mr. J. House, Eastgate Nursery, Peterborough, has an extra prize for a large collection of bedding plants in neat boxes, and very well grown. *Greenovia aurea* is particularly worthy of remark, and *Lobelia pumila grandiflora* is a very dwarf free-flowering kind, excellent for edgings, and forms a mass of blossom. *Iresine Lindenii* is likewise very effective. The *Alternantheras*, especially *amena*, are beautifully coloured.

The only group of wax flowers shown comes from Miss Sutton, of Thame, Oxon., and consists of well-executed *Roses*, *Dahlias*, *Fuchsias*, *Lilies*, &c. This receives a first prize, and a similar award was made to a very elegant group shown by Mr. John House, Church Street, Peterborough, the material used being muslin. An extra prize was also given for a case of skeletonised leaves from J. Kay, Esq., Bidsbury, an excellent example of skilful manipulation.

The best four pots of *Lilium auratum*, for which a special prize was offered by W. D. Cole, Esq., come from Mr. Turner, Slough, and have from twelve to sixteen fine blooms.

Lycopods are creditably shown by some exhibitors, but are not up to the mark of the London exhibitions. *Clematites*, on the other hand, as exhibited by Messrs. Jackman & Son, of Woking, are most excellent. Their first-prize four are *Mrs. Bateman*, *lanuginosa candida*, *rubella*, and *Jackmanni*; besides which they show several other kinds; the plants, grown in tubs, ranging from 5 to 6 feet in height from the ground, and literally covered with flowers. Some very good *Balsams* come from Messrs. Bull & Thorpe, and the same firm send the beautifully grown *Lobelias* shown at a recent meeting at South Kensington, and which they have since acquired. They also take an extra prize for bedding plants. Mr. Ware has a beautiful collection of hardy cut flowers; Mr. W. Paul boxes of *Roses*, *Zonal Pelargoniums*, *Erionymus daveceus*, one of the prettiest of golden-leaved shrubs, *Lilium auratum*, and several of his valuable new *Zonal Pelargoniums*, among which *Avantchey*, at once white-flowered and white-leaved, is not the least prominent. In the local classes are good blooms of *Hollyhocks* from Messrs. Sarman and Minchin, and of *Dahlias* from Mr. R. Parsons. *Fuchsias*, both in the local and general classes, are not remarkable either for size or beauty, nor have we seen them so this year. Mr. Cattell, of Westerham, had a first-class certificate for *Tropaeolum Minde* Warren, dwarf, with leaves having a very decided white variegation, but apparently of weak constitution—at least that was our impression. *Dracaena magnifica* from Messrs. Veitch, with leaves having the blade 15 inches long by 6 wide, is a plant that cannot fail to strike one by its rich reddish mahogany colour and free growth. Mr. Williams has also a very graceful *Horsetail*, *Equisetum sylvaticum*; and though *Horsetails* are not to be encouraged in a horticultural point of view, this one seems well worthy of attention. Mr. Williams also exhibits, not for competition, a magnificent specimen of *Cycas circinalis*, spreading about 12 feet, which is a great object of attraction.

Cut blooms of *Carnations*, usually not only numerously represented, but also very well done at these provincial shows, are well shown on this occasion also. In the nurserymen's class for twenty-four varieties, Mr. Charles Turner, Slough, is first with a very fine lot of blooms, consisting of *Dreadnought*, *Lord Lewisham*, *Lord Rencliffe*, *Oliver Goldsmith*, and *Prince Albert*. *Scarlet Bizarres*; *Anthony Dennis*, *Eccentric Jack*, *Graceless Tom*, *Captain Franklin*, *Rifleman*, and *Young Milton*, *Crimson Bizarres*; *Princess Royal* and *Twyford Perfection*, *Pink* and *Purple Bizarres*; *Colonel Windham*, *Squire Mey-*

nell, *Purple Flakes*; *Annihilator*, *Coronation*, Mr. Battersby, and *William Cowper*, *Scarlet Flakes*; and *James Merryweather*, *Aglaia*, *Flora's Garland*, *King John*, and *Rose of Stapleford*, *Rose Flakes*. Second, Mr. George Edward, York, with much smaller but nice flowers, the best being Mr. Patey, *James Merryweather*, and Mr. Walton, *Rose Flakes*; *Rainbow* and *John Davidson*, *Crimson Bizarres*; *George Edward*, *Scarlet Flake*; and *Mrs. Gunning*, and *Mayor of Nottingham*, *Purple Flakes*. Mr. H. Hooper, Bath, is third. In the amateurs class for twelve *Carnations*, Mr. S. C. Buttrum, Burgh Mills, Woodbridge, is first with a capital lot of flowers, consisting of *Lord Randolph* and *Sir J. Paxton*, *Crimson Bizarres*; *John Bright*, *Rainbow*, and *Tenby Rival*, *Crimson Bizarres*; *Hamiah* and *Sarah Payne*, *Pink* and *Purple Bizarres*; *Premier*, *Purple Flake*; *John Bayley* and *Marmion*, *Scarlet Flakes*; *Flora's Garland* and *Uncle Tom*, *Rose Flakes*. Second, Mr. N. Norman, Plumstead, with *Mayor of Nottingham*, *Purple Flake*; *Poor Tom*, *Rose Flake*; and the remainder seedlings, some of them appearing promising. Third, Mr. D. Pizzey, gardener to Sir C. E. Perry, Fulmer, Bucks.

The special prize offered by the Earl of Abingdon for twelve *Carnations* is also taken by Mr. Turner with a fine lot, consisting of *Lord Lewisham*, *Admiral Chazon*, and *Duke of York*, *Scarlet Bizarres*; *Eccentric Jack* and *Rifleman*, *Crimson Bizarres*; *Princess Royal*, *Pink* and *Purple Bizarre*; *Colonel Windham*, *Purple Flake*; *Sportsman* and Mr. Battersby, *Scarlet Flakes*; *Flora's Garland*, *King John*, and *James Merryweather*, *Rose Flakes*. Second, Mr. N. Norman, with a good lot of seedlings as before. Third, Mr. George Edward, York. Mr. C. Turner is also first in the nurserymen's class for twenty-four *Piotees*, and shows a remarkably fine lot of blooms that draw admiring exclamations from the visitors; they are *Chancellor*, *Colonel Clark*, *Exhibition*, *Lavinia*, *Lord Valentin*, *Mrs. Norman*, and *Miss Turner*, *Red-edge*; *Francis*, *Jessie*, *Mary*, *Mrs. Summers*, *Mrs. May*, and *Picco*, *Purple-edge*; *Elise*, *Lucey*, *Alfred Ingleton*, *Mrs. Rollings*, *Queen Victoria*, *Juliana*, *Obadiah*, and *Parity*, *Rose-edge*, and two seedlings. Second, Mr. George Edward, York. The best flowers in the stand are *Fairest of the Fair*, *George*, and *John Feather*, *Purple-edge*; *Lord Mayor of York*, and *Mrs. Hanford*, *Purple-edge*; *Hannah Maria* and *Harriet*, *Rose-edge*. Third, Messrs. Wood & Ingram, Huntingdon. With twelve blooms Mr. D. Pizzey is first with some good blooms, consisting of *Eliza*, *Rosetta*, and *Forester*, *Red-edge*; *Admiral*, *Francis*, *Gaiymede*, *Jessie*, *Margaret*, *Mary*, and *Mrs. May*, *purple-edge*; *Lucey* and *Princess Alice*, *Rose-edge*. Second, Mr. N. Norman, with *Mrs. Newball*, and *Prince of Wales*, *Red-edge*; *Jessie* and *Margaret*, *Purple-edge*, and the rest seedlings. Third, Mr. W. Broadbridge, gardener, to Sir C. Montaut, Bart., Warwick. The special prize for twelve blooms given by the Earl of Abingdon is also taken by Mr. Turner with a fine lot of blooms that are unnamed, though to all appearance repetitions of what have been previously given. Second, Mr. N. Norman. Third, Mr. T. Payne, Oxford. The *Carnations* and *Piotees* shown in the several classes for the same in connection with the Show of the Royal Oxfordshire Horticultural Society, are pretty good in quality, and consist mainly of flowers, the names of which have already been given. A first-class certificate was given to *Piotee Ne plus Ultra* from Mr. J. Payne, Oxford.

In the open class for twelve *Pinks*, Mr. G. Kirtland, Oxford, is first with pretty good flowers of the *Rev. Geo. Jeana*, *Annie*, *Brilliant*, *Mary Ann*, *Attraction*, *Blondin*, *President*, *Charles Turner*, *Bertram*, *John Ball*, *Victory*, and a seedling. Second, Mr. D. Gammie, Marston, Oxford, the best flowers being *Marion*, *Charles Turner*, and *John Ball*. Third, Mr. A. Evans, Oxford.

Cut *Verbenas* are finely shown by Mr. C. J. Perry, though the close and heated atmosphere of the tents tells severely on them. Mr. Perry is the only competitor for the special prize, offered by Mr. George Prince, for thirty-six kinds, having fine examples of *Nehala*, *James Birbeck*, *Madame Stenger*, *Champion*, *Rev. C. Peach* (new), *Carnation*, a new striped variety; *King of Lilies*, *Rose Imperial*, *Kate Lawden*, *Thomas Harris*, *Ada King*, *Geant des Batilles*, *Model*, *Leah*, *Mr. George Prince* (new), *Rising Sun*, *Annie*, *Rev. P. M. Smythe*, *Velocipede*, *Apollo*, *Black Prince*, *Lord Leigh*, *Fidelity*, *Thomas Lawden*, *Rev. J. Dix*, and *Magnificent*, as the leading varieties. There is no other competitor. With twelve trusses Mr. Perry is also first with *Edwin Day*, *Rev. C. Peach*, *James Birbeck*, *Rev. P. M. Smythe*, *Fidelity*, *Butterfly*, *Rising Sun*, *Mr. George Prince*, *Thomas Harris*, and unnamed seedlings. Second, Mr. H. Minchin, Hook Norton, the best being *Charm*, *Mrs. Pechin*, *Champion*, *Richard Dean*, *James Birbeck*, and *Geant des Batilles*. Of *Verbenas* in pots, the *Rev. R. H. Charsley* has the best, and takes the special prize offered by himself. The plants, which are of good size and pretty well bloomed, are in enormous pots. Some nice, but much smaller plants, come from Mr. H. Sarman, Witney; none of them are named. In the class for *Verbenas* in pots in the schedule of the Royal Oxfordshire Horticultural Society, the same exhibitors occupy similar positions. First-class certificates were awarded by the Floral Committee to *George Peabody* and *Grand Monarch* *Verbenas* from Mr. Eckford, Colchester, and to Mr. C. J. Perry for *Mrs. George Prince*, *John Laing*, *Perfection*, and *Rev. C. Peach*.

In the class for *Achimenes* in pots Mr. G. Hinton, gardener to the Mayor of Oxford, is first with good plants of *Dazzle*, *Dr. Hogg*, *Sir Treherne Thomas*, *Longiflora*, *Longiflora rosea*, and *Ambrose Verschaffelt*. Mr. W. Darley, the Gardens, Digswell, Welwyn, is second

with Dazzle, Grandis, Parsonsii, Sir T. Thomas, Margareta, and Manve Queen. Mr. Hinton is also first in the class for Achimenes in the schedule of the Oxfordshire Horticultural Society.

Some charming young but finely bloomed plants of Gloxinias are staged by Mr. Charles Turner in the class for six kinds. They consist of Glowworm and Henry Husson, erect-flowering kinds; and Rubens, Rose d'Amour, Count Benary, and Distinction, drooping kinds. Perhaps a better and more varied half-dozen could hardly be selected. Mr. W. Hickman, the Gardens, Blethingdon Park, Oxford, is second with Princess Beatrice, Sultan, Bridesmaid, and Nimrod, erect-flowering kinds; Queen Victoria, very pretty, and Princess Royal, with pendant flowers.

DINNER-TABLE FLORAL DECORATIONS.—A proverb will often throw a sunbeam of light over that which from a mere custom is becoming hazy and obscure. We are not at all prepared to sail with the stream in the present enthusiasm for dining-table decoration. We have a lingering belief that there should be a place for everything, and every one thing should be kept in its place. The office of a dining table is to present eatables and drinkables to the good people who sit around it. We have no desire to be barbarian enough to see a huge table loaded with a whole roasted ox, sheep, or pig; but at the risk of being considered old-fashioned, we like to see the joints of which we partake in the good old English style, instead of the slices on a plate, brought in the mode *à la Russe*, so much in vogue, which puts us in mind of the eating-house, instead of the home and the mansion. Attempt by presumed refinement to disguise it as you will, the natural principle remains, that it is most pleasant to partake of the little you want from a large, next-to-an-inexhaustible supply. When we have dined *à la Russe*, what we call next place to eating-house fashion, if we felt we could take another slice, we have been deterred by the thought that there might not be enough for others. When we see before us the round of beef, and the leg and shoulder of mutton, &c., we see there may be "cut and come again," and that we may have what we want without depriving others of their legitimate share. If a man is considerate at any time he ought to be so when he dines in company. Well, we are old-fashioned enough to like the old ways, and to inhale the fragrance of well-cooked meat and vegetables, as well as partake of them for our nourishment. In such a case we want no sickening aroma from flowers to mingle with the aroma from the joints. We have no objection to a few flowers and sprigs of vegetation to give a pleasing diversion to the eye, but as the object in sitting down at the table is to eat, these floral decorations on the old English system should never be rendered more lofty and conspicuous than the joints to be demolished. More latitude may be given on the *à la Russe* style, where the table may be at once furnished with the dessert and rendered somewhat ornamental with plants and cut flowers. The mischief is, that people forget that the dining-table, if it keeps its place, is a place to eat and drink at. All floral ornament and devices should, therefore, be of a very secondary instead of primary importance. We have read of an emperor long ago who had silver shoes for his horse, and a golden manger from which to eat his oats. Were the oats a whit better than if they had been taken from iron or wood? Is it a bit more truly refined to attempt to turn an eating-table into an aquarium, a fernery, or a neat conservatory? Everything in its place, gentlemen. When you dine, let dining be your object, and not the contemplation and study of floral display. A few men with wondrous minds can enter into the consideration of many things at once. We believe that the great masses can only thoroughly enter upon one subject at a time.

We like every one, however, to gratify his tastes, considering he has a perfect right to do so if he interferes not with the rights and pleasures of others. Even on the *à la Russe* plan, the ornamentation should never be so conspicuous as to lead the diner for a moment to forget he is at a dining table. A few Ferns in low vases, and cut flowers in low dishes, will generally tell the best, as not interfering with the reverse and free sight of the diners on each side of the table. For want of attention to keep floral decoration lowly and subordinate, we have seen pretty high glasses and vases of flowers on the dining table, that we wished could be transferred to side tables, or to the drawing-room, where, placed singly or in groups, they would become objects of attraction, more especially if the aroma was not overpowering. This latter observation would open up a large field of remark and observation. Our own opinion is, that in many cases the something like rage for cut flowers in rooms is furnishing more than is dreamed of—occupation for our medical friends. A growing plant with light in a window is a source of health to the inmates of that room. A plant, though green, set on a table, or in recesses where no direct light reaches it, is anything but a source of health to the human occupants. Cut flowers unrelieved with plenty of green, are always more injurious than beneficial in confined places, and especially at night. Did we consider the fitness and the place for things, we would have fewer plants and cut flowers where we could not give them light, and feel more pleasure in examining them under conditions more favourable to their health and our own.

Feeling power's to arrest the stream of floral decoration, but with some small hope, with the help of others, of so directing it in its course that it may not become a noxious extravagant mania, we will shortly notice a few of the matters of ornamentation that struck our attention at Oxford. And first of the three groups of flowers, or of flowers and fruit, suitable for the decoration of the dinner table, Class 96. Of the

three lots nothing is attempted with fruit, and hence all are on something like equal terms. Mr. Perkins, Lacomington, who takes the first prize, has a pair of low glass plates, each having a column of twisted glass supporting a smaller and rather shallower glass vessel or vase. The lower vases are nicely done with fine flowers of Allamanda, Roses, Pelargoniums, all rendered light and airy by dressings of Maiden-hair and the neat miniature flowers of a great beauty for this purpose, the Gypsophila repens. The upper vases or epergnes are draped with Maiden-hair and Fuchsias, and the flowers are equally well arranged. The centre of the three is a glass vase on a pedestal and base, raising the vase some 9 inches in height. This is dressed equal to the others, and in this vase a central column rises, terminating in a tube or trumpet-mouthed glass, with Fuchsias, &c., depending. From the centre of the lower vase rise three wide-mouthed tubes to about half the height of the central one, and furnished in a similar light and easy manner. Then, in combination with these, there are some thirteen glasses some 7 inches in height, and averaging an inch across at the top; these are dressed chiefly with Maiden-hair, some have a single Rose or had others a few choice flowers. Sitting at the table, the upper glasses of the three are above the line of vision, but are pleasant to look up to. Our chief objection to the central one is the three central tube glasses that rise about half the height of the central one. This would have enhanced its beauty as a separate article in the drawing-room or on a side table. Looked at merely as an ornament of the dining table, the centre vase is rendered more lumpy and less airy and graceful than its companions. We are just in great doubt whether, looking to fitness and appropriateness, these beautiful glasses, just filled as they are, would not have been as well without the columns and the upper epergnes. They would have been more simple.

Mr. Chard, Clarendon Park, Salisbury, is second with another simple arrangement, simpler even than the last, though the same remark will apply to the elevated epergne. This consists of three flat glass dishes resting on the table some 18 inches in diameter, with brass rods or columns supporting another shallow glass epergne some 10 inches in diameter. Two columns are festooned with climbing Fern, the central one with Cissampelos discolor. All these are dressed at the base with the common Male Fern. Two are filled chiefly with Roses, relieved with Maiden-hair and rather thickly studded with Grasses, the centre Grasses being some 15 inches long. A few Grasses give lightness, too many make a vase of flowers look common and poor. The common Fern dressings as a base are also rather long—some 15 inches beyond the glass, and therefore taking up considerable room. The central glass is similarly dressed, only is furnished with Allamandas, Begonias, and finer flowers. Here the height of the upper epergne leaves plenty of room for opposite guests to see and converse, and the Grasses from the fields make all look simple; and yet nevertheless, just as in the last case, we are in doubt if the upper epergne is an improvement.

The other exhibition, that of Mr. Spiers, of St. Giles's, Oxford, consists of three shallow glass epergnes, raised by base and pedestal a foot above the tablecloth. Each of these has a central column terminating in a wide-mouthed tube some 18 inches in height. From the base of this column rise three other columns rising about half the height of the central one, then circling over like a crooked horn, and terminating in a hook to hold each a little long glass basket. The three lower epergnes are based with the common Male Fern and the common Bracken, are then edged with leaves of Mrs. Pollock Pelargonium, and a variety of flowers used for grouping upper and lower epergnes and the suspended baskets. Looked at individually on a side table each of these would be interesting; as adjuncts to the dining table, the triple columns and the hanging baskets make them heavy.

In Class 97, Hand Bouquets, one pretty vase is shown by Mr. Hense, of Peterborough, but not entered, edged with Maiden-hair, and nicely blended with Stephanotis, Crassulas, Mar. ch. Niel Rose, and Pelargoniums. It wanted relief at the centre. That exhibited by Mr. Perkins is very pretty. Edged with lace paper, a Maiden-hair; filled with a nice mixture of small Roses, Pinks, Carnations, scarlet and light Pelargoniums, relieved with dots of Maiden-hair, other little green bits, and dots of Forget-me-not. Mr. Earley, of Digswell, Welwyn, exhibits a very graceful and airy bouquet, the best flowers lightly relieved by Maiden-hair Fern and small Grasses. Mr. Hill exhibits a nice arrangement, relieved with sprigs of Maiden-hair. Mr. Chard, of Clarendon Park, has a very simple arrangement: some good flowers, as Heaths and Clerodendrons, being rather too much relieved, though made light and airy, with Grasses and Ferns.

The prize offered by the *Journal of Horticulture* for the best dessert of fruits combining excellence of quality with taste in arrangement, has failed even more than hitherto in securing the object aimed at. There is not the slightest attempt made at taste in arrangement. I had hoped to have learned a lesson here, and so far have had my journey for nothing. I dearly wished to open up the question of dressing fruit with flowers, &c., but here there was not the vestige of a chance. There was a great deal of fruit altogether, but nothing above the usual average. Some six or seven Queen Pines; four of Grapes Black and White, retaining the traces of sulphur or dirty water; two of Nectarines, Violette Hative and Pittmaston Orange, the former fair; three of Peaches, one dish at least rotten and gone; two of Strawberries, good but for retaining traces of the packing; two of Cherries, fair; a good Melon, Prizefighter; and a plateful of the small Royal Ascot Melon, and very small Turkey Figs. I give every credit to

the proprietors of the *Journal of Horticulture* for their kindness and their wish to advance horticulture and the best interests of horticulturalists, but I think they had better give up giving such a large reward for a single exhibition. The successful exhibitor is Mr. Miller, gardener, Workshop Manor.

The *Gardeners' Chronicle* is more fortunate than the *Journal of Horticulture* in this respect. There was a keen competition, and very good things were exhibited. The first prize for the best six kinds at least of fruit and vegetables, was taken by Mr. G. T. Miles, gardener to Lord Carrington, Wycombe Abbey, Bucks. The collection consists of a beautiful dish of Barrington Peach, three bunches of Buckland Sweetwater Grape, bunches not large but beautifully yellow-coloured; one fine Queen Pine, one Scarlet Gem Melon, a dish of Downton Nectarine, and one of blue Plums. The vegetables are equally good, consisting of long, crisp French Beans, Asparagus, fine for July; Globe Artichokes, flat Tripoli Onions, fine; Broad Wonderful Bean, and Myatt's Prolific Potato, very fine. The second prize was awarded to Mr. Simpson, gardener to Lord Wharcliffe. In this collection were two nice Queen Pines, two Melons, incomparable and Queen Emma; two dishes of Peaches, and one of Nectarines, rather small; three bunches of Black and three of White Muscat Grapes, not ripe; one dish of Dr. Hogg Strawberry, one of White Cherry, and one of Brown Turkey Fig, good. The vegetables consist of French Beans, Carrots, Onions; Peas, No Plus Ultra, Premier; Kidney Potatoes, &c. There were also some nice fruit and vegetables in Mr. Challis's and Mr. Keen's collections.

FRUIT.

Fruit is tolerably well represented, the Grapes coming well to the front, and proving by far the most attractive feature of the Show, and of these we would particularly notice the very meritorious collection of Grapes from Mr. Speed, Chatsworth, which are specially interesting and remarkable (these are not entered for competition). They are the produce of Vines thirty-seven years old, which had been rejuvenised, as stated, by adopting the extension system of pruning. The examples are as follows:—Black Hamburgh, the bunches large, about 3 lbs., perfect in bunch and berry; Black Prince, fine large bunches, beautifully coloured, and excellent; Mill Hill Hamburgh, with very large berries, and altogether splendid.

For the prize offered by Professor Lawson, of Oxford, for six varieties of Grapes, the second and third by S. Davis, Esq., and Mr. Sheriff Hauley, the competition is very spirited, Mr. Turner, of the Royal Nurseries, Slough, being awarded the first prize very worthily for very excellent examples of Royal Ascot, Alicante scarcely coloured, Black Prince, Black Hamburgh, Buckland Sweetwater, and Muscat of Alexandria, the second being awarded to Messrs. Lane, Berkhampstead, for nearly equally fine examples of Golden Champion, large in bunch and berry, but quite unripe; Buckland Sweetwater, Foster's White Seedling, Black Prince, and Black Hamburgh. Mr. Wallis, gardener to J. Dixon, Esq., Aske Park, Congleton, is awarded the third prize for fair examples of Black Hamburgh, Mill Hill Hamburgh, Black Prince, Royal Vineyard, and Black Frontigann. Mr. W. Colegrave, gardener to S. Davis, Esq., Swoiford Park, Ennetone, and Mr. Broadbridge, gardener to Sir C. Mordaunt, Bart., Walton House, Warwick, also exhibit.

In the class for six distinct dishes of fruit, offered by the Local Prize Fund, there are five competitors. Mr. Miles, gardener to Lord Carrington, is awarded the first prize for Stillward's Sweetwater Grapes, magnificent examples of Galande Peaches, small Queen Pine, Elruge Nectarine, Elton Cherries, and a very poor dish of Strawberries. Mr. Broadbridge is placed second with a very fine dish of Muscat of Alexandria and Black Hamburgh Grapes, good Grosse Mignonne Peaches (named Barrington), fine Elruge Nectarines, small Moscow Queen, and a very poor Treantham Hybrid Melon. Mr. J. Wallis, gardener to J. Dixon, Esq., Aske Park, is awarded the third prize, who exhibits magnificent examples of Barrington Peaches, good Nectarines, fine Cherries, and Black Hamburgh Grapes, the Pine Apple here being the weak point. Mr. Harwood, gardener to E. Greaves, Esq., M.P., Avonside, Warwick, and Mr. Clark, gardener to Earl Cowper, Brocket Hall, also exhibit.

In Class 60, collection of fruit, twelve dishes, there was no competition, the only exhibitor being Mr. W. Clark, gardener to Earl Cowper, Brocket Hall, who was awarded the first prize. His exhibition consisted of two fair Queen Pine Apples, Bowood Muscat Grapes quite green, and Black Hamburgh ditto poor in colour, very fine Galande and Grosse Mignonne Peaches, Hunt's Tawny and Elruge Nectarines, Early White Figs, a good Melon, Apricots, and a dish of Bigarreau Napoleon Cherries.

In Class 63, single dish of Black Grapes, there was a very excellent competition. Mr. W. Coleman, gardener to Earl Somers, Easton Castle, Ludbury, Hereford, who exhibits magnificent examples of Black Hamburgh, the bunches weighing over 4 lbs., perfect in bunch and berry. These are the finest examples in the Exhibition, and are awarded the first prize. Mr. Smith, gardener, Exton Park, Oakham, is placed second with smaller but very fine examples of the same; and Mr. C. Turner, Slough, the third, with small bunches, but well-finished examples of the same variety. Mr. J. Ratty, gardener to J. Scholfield, Esq., Turville Park, Henley-on-Thames, stages good examples of Black Prince. Mr. Colegrave also exhibits.

In Class 64, three dishes of Muscats, the competition was also good. The first prize is awarded to Mr. J. Thomas, gardener to Mrs. T. Drake

Bignell, Bicoster, who shows splendid examples of Muscat beautifully ripened, and very perfect in every respect; Mr. Turner, of Slough, being placed second with nearly equally good examples of the same, but scarcely so good in colour; Mr. Janson, gardener to T. Statter, Esq., Stand Hall, Manchester, is awarded the third prize for very good examples of the same. Mr. W. Colegrave exhibits also fine examples of Buckland Sweetwater, large in bunch and berry.

In Class 65, baskets of 12 lbs. of Grapes, a very good competition takes place. Mr. Coleman is placed first with fine examples of Black Hamburgh; and Mr. Thomas, second, with good Muscats. Mr. Smith, gardener to H. Walker, Esq., Calderstone, Liverpool, with Black Hamburgh; and Mr. Standish, The Royal Nurseries, Ascot, with Royal Ascot, are placed equal third with really excellent examples. Mr. Ward, gardener to T. N. Miller, Esq., Bishop's Stortford, exhibited a most magnificent basket of Gros Colman, with berries of enormous size, and of truly beautiful appearance, to which an extra prize was awarded. These were extremely meritorious. For appearance this Grape surpasses all, but in flavour is very inferior. Mr. Smith, gardener, Exton Park, exhibits a fine lot of a Black Hamburgh; and Mr. Janson has also an excellent basket of Black Hamburgh and Canon Hall Muscat. Mr. Broadbridge, gardener to Sir C. Mordaunt, and Mr. C. Turner also exhibit.

In Class 61, three Pine Apples, the competition is very good, seven lots being staged. Mr. Paten, gardener to H. S. Lacey, Esq., Charlotte Park, Warwick, is placed first with three handsome, well-coloured fruits of two Moscow Queens and a Smooth Cayenne, the second prize being awarded to Mr. C. Allen, gardener to J. Clegg, Esq., Withington Hall, Cheshire, with three handsome Providence, very even in size, and well finished-off, Mr. Gardiner, of Eaton Park, coming in third with two very even Moscow Queens, and a very good Providence. Mr. G. Ward is third with Charlotte Rothschild, 7 lbs. 10 oz., and a Smooth Cayenne, 7 lbs. These are rather over-ripe. For single Pine Apples, the first prize was again awarded to Mr. Paten, for a well-ripened Enville Queen with a number of crowns, weighing 8 lbs. 14 oz. The second prize went to Mr. Gardiner, and the third to Mr. Ward.

In Class 66, Peaches, single dish, Mr. J. Wallis, Aske Park, is placed first with very excellent examples of Barrington. Mr. Miles, second with the same; and Mr. Sage, gardener to Lord Brownlow, third with Bellegarde. Mr. Ratty, gardener, Turville Park, showed excellent examples of Galande.

Nectarines are not well represented, excepting in the prize lots. The first prize went to Mr. H. Take, gardener to R. Nicholls, Esq., Brunley, Leeds, for good Violette Hative; and Mr. Miller, Workshop Manor, was second for the same; Mr. James, gardener to the Duke of Newcastle, is third. Good examples of Hunt's Tawny are shown by Mr. Turner, and Elruge by Mr. J. Day, gardener to A. Seymour, Esq., Norton Hall, Daventry.

Apricots are but poorly shown; Mr. Smith, gardener to the Earl of Gainsborough, being placed first with Blenheim, and Mr. Earley second with Moorpark.

In Figs, the first prize is very deservedly awarded to Mr. Sage, gardener, Ashridge Park, for finely-ripened Brown Turkey; the second to Mr. Harvey, gardener to P. Wroughton, Esq., Woolley Park, Wantage, for the same; and the third to Mr. J. Day for Marseilles.

In Cherries there is a good display; Mr. Turner, of Slough, being placed first with Bigareaux, and Mr. J. J. Chater, Gonville Nurseries, Cambridge, second with the same; third to Mr. Smith, Exton.

Strawberries, six dishes—there is only one exhibition, by Mr. D. T. Irvine, gardener to the Duke of Hamilton, Easton Park, Wickham Market, who is awarded the first prize for Crimson Queen, Nimrod, Frogmore Late Pine, Sir C. Napier, Myatt's Surprise, British Queen.

Strawberries, single dish. The first prize is awarded to Mr. Maunder, gardener to the Earl of Abingdon, Wytham Abbey, Berks, for excellent Eleanor; the second to Mr. T. Blome, Rhug Gardens, Corwen, for British Queen, very good.

In the classes for Melons there is, as usual, a strong competition. In the class for green-fleshed, twenty-four varieties being staged, the first prize is awarded to Mr. Gardiner, of Eaton Park, for Golden Perfection, the second to Mr. James, gardener to the Duke of Leinster, Carton, Maynooth, and the third to Mr. D. T. Fish for a green-fleshed variety, named Turner's Scarlet-fleshed. In Scarlet-fleshed the first prize is awarded to Mr. Bailey for Royal Ascot, the second to Mr. Carmichael, Sandringham, and the third to Mr. Earley.

Plums are poorly shown. Mr. Miles, gardener to Lord Carrington, is first with Kirke's, Mr. Janson second with the Peach, and Mr. Lockie third with July Green Gage.

Out-door fruits, four dishes. Two equal first prizes are awarded to Mr. Turner, of Slough, for very excellent Frogmore Late Pine Strawberries, large Early Apricots, Black and White Cherries; and to Mr. T. S. Irvine, gardener to the Duke of Hamilton, for well-kept Northern Greening Apples, Black Circassian Cherries, British Queen Strawberries, and Black Currants.

In Class 111, prizes offered by H. M. Gammon, Esq., for three varieties of Vines in pots, Messrs. Lane & Son, of Berkhampstead are the only competitors. They exhibit three very large plants in pots 10 inches in diameter, profusely laden with fruit, which is, however, of not much merit. The varieties are Foster's White Seedling, Black Hamburgh, and Royal Ascot. The first prize was awarded.

In Class 112, six orchard-house trees in pots: the prizes offered

by the Baroness Wenman, H. Wykeham, Esq., and H. C. Tawney, Esq., Messrs. Lane again had the field to themselves, and were awarded the first prize for very fair examples of a Peach and Nectarine, Apple and Pear, Plum and Cherry. The exhibition here is, however, by no means so good as we could have expected. Vegetables will be noticed next week.

FRUIT COMMITTEE, July 20th.—G. F. Wilson, Esq., F.R.S., in the chair. Messrs. Standish & Co., of Ascot, sent a seedling Grape called Citreulle Muscat, in appearance much like Chasselas Musque, and much resembling it in flavour. The Committee requested that it should be sent again later in the season. Mr. Eckford, gardener to the Earl of Radnor, Coleshill, again sent his seedling Grape, named Coleshill White Hamburg, which too closely resembles the old White Tokay, to be of any value as a new variety. From Mr. Anderson, gardener to the Earl of Stair, Oxenford Castle, came a seedling Strawberry, named Moffatt's Duke of Edinburgh, raised from Keen's Seedling, crossed with Elton Pine. Fruit very large and extremely handsome, but very deficient in flavour. Mr. T. Elcome, Rhug Gardens, Corwen, sent a seedling Strawberry named Owen Glendower, but of no merit. Mr. Gilbert, Brnleigh Park, sent a seedling Cherry, raised at Brnleigh more than thirty years ago. It was somewhat in appearance like Bigarreau Napoleon, but more acid. It received a first-class certificate. Mr. Smith, gardener to the Earl of Gainsborough, sent some Scarlet Gem Melons, stated to have been grown in the open air. Mr. G. Lee, Clevedon, Somerset, sent Lee's Prolific Black Currant, which had before received a certificate.

EXTRACTS FROM THE REPORT ON THE BRISBANE BOTANIC GARDENS.

ENCOURAGED by the great success of the growth of the Palms and the Cycads made in the compartment of ground set apart for them near the aviary, and the great interest taken in them, a new plantation has been formed adjacent to the residence of the Director, and many of these graceful and highly useful trees have already attained to dimensions of considerable importance; they consist of the Cocoa Nut (*Cocos nucifera*), the African Oil Palm (*Elaia guineensis*), the Date Palm (*Phoenix dactylifera*), the Wine Palm (*Caryota urens*), the Cabbage Palm (*Oreodoxa regia*), the Sago Palm (*Sagis Rumphii*), the Sago Palm of Queensland (*Sagis Blackalli*), the Wax Palm (*Ceroxylon andicola*), the Betel Nut (*Areca catechu*), &c.

Of the fibrous plants the Clivia Grass-cloth plant (*Bahmeria nivea*), still continues to thrive exceedingly well, but though many have essayed to prepare it for manufacturing purposes, all have most signally failed. It has been experimented on by those who have spared no pains, and on every occasion with similar results. The remaining fibrous plants consisting of the Jute (*Corchorus capsularis*), the Sun Hemp (*Crotalaria juncea*), the Queensland Hemp (*Sida retusa*), &c., are thriving, and gradually gaining favour among those interested in the cultivation of what may yet become a new and important branch of industry. The Cotton Plant was doing extremely well up to the late rains, which, however, have severely checked its development. Some five or six varieties have been furnished to this department, during the six months, for experimental purposes, and are now bearing; one or two of these varieties promise to prove an acquisition to Queensland planters.

Of the dye plants the Indigofera tinctoria (Indigo), the Rubia tinctorum (Madder), the Lawsonia inermis (Henna plant), and the Cochineal insect, &c., still continue to prove their adaptability for successful cultivation in Queensland.

THE STAPLEHURST ROLLER BARROW.

ALL who have grass lawns, and flower beds around them or in these, know full well how very inconvenient it is to go to work on them with a barrow, especially after wet; the wheel makes such marks in the grass that the work seems almost useless. I have lately seen a very ingenious contrivance brought out by Messrs. Pollard, Urquhart, & Co., of Bear Garden, Southwark, entitled the roller barrow; it is made of iron, and there is no wheel, but in lieu of it there is a broad roller, which, instead of making marks and spoiling the grass, really improves it, and, of course, the fuller the barrow the better is the result produced. It is exceedingly light, can be moved by a boy, and is, I think, a contrivance well worthy of attention by all those who pride themselves upon the condition of their grass; it will also save the tearing-up of walks by the wheel, barrow in wet weather. With care it is likely to last a lifetime.

and thus again has an advantage over the old wooden barrow—D., Deal.

[We conclude that the Staplehurst barrow is the same as that described as follows in the *English Mechanic and Mirror of Science*. "The peculiarity of this ingenious invention is, that it causes no unsightly scores or marks upon lawns or walks in wet weather, when the use of the ordinary wheelbarrow is a source of constant disfigurement. It is easily worked by a boy, though it can be rendered of any weight desired by filling it up with ballast, the load being discharged at once by tipping the

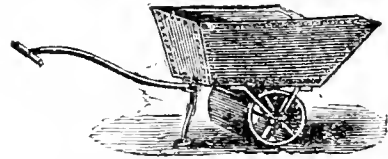

handle. It is very serviceable for bedding-out plants, carrying away cut grass or turf, gathering up leaves, or when manuring the ground. The roller barrow is equally adapted for grass lands where horses and carts cannot be employed, and for croquet lawns, being always sufficiently light to be managed in case of need by a lady. It is in use at the Crystal Palace, Kensington, and other gardens, where its handy qualities have rendered it a permanent favourite."

Another combination is of the roller and watering engine, made by Mr. J. Dove, 17, Exmouth Street, Clekenwell.

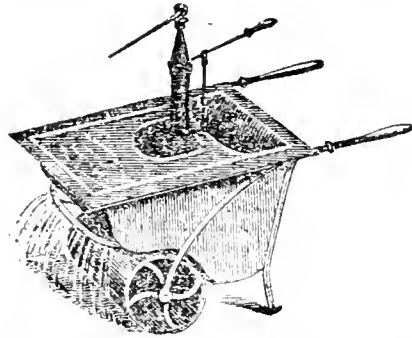

The advantages of this neat little garden machine may be seen in not only throwing water a distance of about 60 feet, but of watering and rolling grass or gravel walks at the same time, so that while two wheels would in either case be injurious, this roller absolutely does good, and is so portable that any ordinary domestic may use it.—Eus.]

STANDARD ROSES.

THERE is a trifling art or secret in the budding and preservation of standard Roses, perhaps not observed and practised by our roarians generally. I refer to the need of one good bud at least on each side of the standard, not opposite exactly, but 1½ or 2 inches distant, betwixt the buds on opposite sides, to form somewhat equal heads and flower shoots. And I allude to the necessity of a clean-cut or eawn standard apex or point, not more than 1 inch beyond the highest bud, and protected by a cap of grafting wax or pitch (a thin patch), to preserve the core of the standard from decay, and the wood of the standard from dying down to the buds, and the decay thus reaching and destroying the buds also. Long standard remnants above the buds carelessly cut admit the air and frost into the cavity of the decayed core, like a mown Thistle stem, and hence our standard Roses perish. I say protect the ends by capsules of wax, pitch, or tar for preservation.—Reader.

LAWN MOWERS.

HAVING read the letter of "Vitis" on the subject of the Archimedean mower, I write to give you my opinion on the value of the machine. I have at present a 30-inch machine of Green's, and a 15-inch one made by Kennan of Dublin. The two are equally good. I purchased this year a 14-inch Archimedean, and the result is that I find one man or well-grown lad can work it with greater ease than a man and boy can work

Kennan's, which is much the same as Green's. It does not do such perfect work as either of the others, but the ribbing is so regular that it is not unsightly; it has rather a quaint appearance when seen in a strong light, that is all. It is much more liable to notch than the others if it meets a stone, but stones ought to be cleared off for any machine.

I never sweep after the Archimedeon, and have taken a hint from it, as I now have taken off the box from my other machines, and allow the grass to scatter. This is practically no eyesore, as the grass is not seen after a few hours, and, if too much gets collected on one spot, it is easily scattered with a broom.

Another great advantage the American mower has—it will cut the grass when it is wet. I have no experience as to whether it will cut long grass.—A SUBSCRIBER, *Co. Clare*.

NOTES AND GLEANINGS.

A NATURAL HISTORY ASSOCIATION has been established at NATAL. Besides many successful researches in ornithology and entomology, our contemporary *Nature* notices that in botany the Association reports a new climbing Scrophulariaceous plant, *Buttonia natalensis*, discovered by Mr. E. Button, and of a new Date Palm, detected by Mr. McKen, Curator of the Natal Botanic Gardens. The colony may be congratulated on possessing so energetic a Society.

WORK FOR THE WEEK.

KITCHEN GARDEN.

As we have been favoured with rain at last, and as there is some probability of its being general, I cannot do better than urge the importance of attending at once to those crops of the kitchen garden which must constitute the chief supply for the coming winter and spring. Planting out *Celery* in its various stages, *Broccoli*, *Cauliflowers*, *Brussels Sprouts*, *Savoye*, *Kale*, and many other useful vegetables, should be a matter of frequent occurrence. The ground from which early Peas, early Potatoes, early Beans, Winter Spinach, &c., have been cleared will come in for this purpose. Exhausted plots of Strawberries, too, after the fruit is gathered, will be excellent as a change for the better Broccoli and Cauliflowers. Deep digging and heavy manuring must be resorted to in all these cases, more especially for the *Celery*, which cannot be produced of a tender and crisp character, if lacking manure and moisture. Keep the succession beds of Horn Carrots thinned in due time. A considerable breadth of *Endive* should be planted out without delay; in fact, one-half of the crop. High manuring is absolutely necessary to produce this valuable salad in perfection. In planting succeeding crops, keep raising the beds higher as the season declines. Let a good breadth of ground be duly prepared for *Winter Spinach* forthwith, by thoroughly trenching and burying a good coat of half-rotten manure in the bottom. It generally succeeds best in highly-raised beds, stagnation being its chief enemy. An autumn *Mushroom* bed should now be made. Throw the dung together to ferment for a few days; when half dry mix one-third of loamy soil with it to keep in check any further fermentation, and tread or beat hard whilst building the bed, making the spawn holes immediately the bed is finished, to assist in keeping down the heat. Strawberry runners should be procured for new plantations without delay. Those who cannot spare ground for a new plantation may prick them out in prepared beds about 6 inches apart, and remove them with balls in October or the early part of February.

FLOWER GARDEN.

No flower is more popular or more useful than the Rose, whether as standards by the sides of promenades, in beds or masses, festooned about pillars, or enlivening the conservatory in the depth of winter. For all these purposes Roses demand a considerable share of attention, especially at this period. Budding, cutting-striking, final potting, &c., are processes of paramount importance at the present moment. The Hybrid Perpetuals, Teas, Bourbons, and Chinas are the most eligible classes from which to select kinds for pot culture. The following are good old kinds for a winter collection on account of their general utility:—Devoniensis, Cramoisis Supérieure, La Pactole, Caroline, Elise Sauvage, Comte d'Eu, Coupe d'Hébé, Prince d'Estéshazy, William Jesse, Princess Maria, Clara Sylvain, Anhernon, La Reine, Madame Laffay, Duchess of Sutherland, Earl Talbot, Belle de Florence, Bourbon Queen, and Crimson Perpetual. The Persian Yellow and Harrisoni have also been

found to force tolerably well. Proceed with Rose-budding without delay. Keep down all suckers, and clear the stems of wild shoots. See that all hips are cut away from those which blossomed early; these exhaust the plants much. Strong shoots of Chrysanthemums may now be layered in pots to produce dwarf and compact bushes. Those in pots may soon receive their final shift. The layering of Carnations and Picotees must be proceeded with as rapidly as possible, it being a point of great importance to have the plants well rooted and established before placing them in their winter quarters. More of the next year's success, as to fine, healthy growth, &c., depends on attention to this matter than many people are aware of. All seedling plants should be marked and layered, noting their various properties as to form, colour, texture, pod, &c. Should any seedling, otherwise fine, have serrated petals, it will be advisable to propagate it, as growing it in another situation may, to a certain degree, rectify this defect, for some of our best varieties will come occasionally, when poorly grown, very rough on the edge. As the blooms decay, extract the faded petals. Amongst the best old flowers are Matthew's Enchantress, purple Picotee; Fletcher's Ne plus Ultra, light purple; Barringer's Unique, red Picotee; Galliff's Proconsul, a very fine heavy-edged rose Picotee of extra form and substance; and Eason's Admiral Curzon, scarlet bizarre Carnation. Plant out rooted cuttings of Pinks on beds of well-prepared soil, but not too rich. A second crop of pipings may also be inserted where an increase of stock is required. Seed may also be gathered, retaining rather long stalks; tie half a dozen together, and allow them to dry well, after which the heads or pods of seed may be put in small paper bags, which may be fastened round the stems and then hung up in a dry, airy situation till wanted. Seedling *Auriculas* which had been put out in pans or boxes in spring will now have attained a considerable size; they may be potted in pint pots (singly) in equal parts of good sound loam and leaf mould, and placed in the shade.

GREENHOUSE AND CONSERVATORY.

The pot Roses intended to flower in the conservatory late in the autumn should now receive whatever pruning is necessary. All those which require a shift should have it forthwith, in order that they may have their pots full of healthy roots by the flowering period; this, and the application of liquid manure, together with a sweet and mild atmosphere, will perform wonders. After these operations they should be placed in some open and airy spot, and if plunged in ashes they should be frequently turned, or the interior of the pot will be without fibrous roots. Give them regular waterings, and persist in picking off all blossom buds as they appear from those required to blossom in November and December. Let the *Camellia* buds have a thinning as soon as possible. Look out and encourage a lot of good things for a late autumn display. *Fuchsias* and *Achimenes* in succession, and even choice *Verbenas* in somewhat thick masses in wide-mouthed pots, will add to the general effect. Remember that all those plants required to blossom in midwinter must have their final shift betimes. There is no success in forcing, or even retarding, without a plentiful of roots.

STOVE.

Stove plants in general have made a good growth; the next point is to have the growth matured. To this end give a still freer circulation of air, and avoid shading as much as possible. The propriety of a second house for Orchids will be more readily seen at this period than, perhaps, any other. The early-growing kinds, several of which are winter or early-spring bloomers, will now require the withdrawal of a portion of the atmospheric moisture still necessary to many others. Several of them, such as the *Cattleyas*, might be removed to a vinery were it not for the attack of snails and slugs. In cases where the whole stock must be grown in one house, it is advisable to keep a free circulation of air by day at this period, and even all night; if possible, endeavour to have a good source of atmospheric moisture in the latter half of the day, and dispense with shading as much as possible.—W. KEANE.

DOINGS OF THE LAST WEEK.

KITCHEN GARDEN.

Dry as ever, but we never had better Lettuces for all the heat, and that chiefly owing to sowing them, and thinning and mulebing. The roots catered for themselves. Transplanting Lettuces without watering and shading in such weather would

be merely labour thrown away. Mashed Peas, Beans, Cauliflowers, &c., with anything and everything we could get hold of, and it is wonderful how the mulching tells in relieving the roots and enabling them to pump up moisture to meet the demands of the sun on the large foliage. All in all, we have never had better Cauliflower, but it has given us extra trouble and labour. Again, never had we better Ashleaved Kidney Potatoes, and never earlier out of doors, and yet the soil about them and around them was as dry as dust. Later kinds, however, are not doing so well, some of them are tubering slowly. Even Early Shaws, pretty early, and generally a great bearer, is far from equalling the Kidneys. Myatt's Ashleaf is perhaps the best for forcing, but the Prolicof others is fine for out-door work. We attribute the great yield in our case partly to a dressing of lime which the ground had not received for many years. This helped to decompose more rapidly the organic matter in the soil, and helped also to make the soil a better retainer and absorber of moisture, however obtained. We fear, if this dryness continues, the haulm of the late kinds will wither before the tubers ripen. The dryness has forced us to make some planting depend on our ability to give a watering when first turned out. Those moved with balls hold their own pretty well; those turned out with the dibber hung their heads unless they had moisture at the roots.

We were pleased to notice the communication of Mr. Castle, at page 11, on *no watering*. Our attention has been directed to it by several amateur correspondents, who say they are in a perfect maze between our little and peculiar watering at the roots beneath, and keeping the surface as much as possible dry, and Mr. Castle's no watering at all. In our circumstances, even at bedding-out time, and watering our plants in beds and trenches previously, and lifting the plants with balls well moistened, and planting them at once in the moistest soil, we could not have done without a little watering to settle the roots, and encourage them to progress, because our soil was in general so dry, and we only secured a little moisture beneath by keeping the soil there, and not bringing it to the surface. The great key to the difference between our treatment and that of Mr. Castle, and both we presume successful, is to be found in the statement, page 11—"Between March and May we have much cold weather." The plants being, therefore, well watered as often recommended beforehand, the roots have a comparatively moist soil to go into, and, therefore, need but little watering, though a little given at the roots, and not a surface dressing, would have done in our opinion no harm, but some good as preventing anything like a check. We are quite as much opposed as Mr. Castle to every-day watering. We know that in many circumstances the cold thus produced by rapid evaporation cools the roots of the plant, but that is not owing to the water in these circumstances being colder than the soil immediately round the roots, unless trouble has been taken to turn down subsoils, or in other words the heated soil of the surface, for water fully exposed will generally be found little or no colder than the soil within 4 or 6 inches of the surface, unless that has been artificially heated by the turning-down mode just referred to, and that plan, however good in general, we could not practise this year, as if we had done so, the soil to the depth of the turning would have been like so much ashes taken from under a grate. It is the rapid evaporation from the surface that cools the soil; but, then, that is avoided when the watering is so given as to leave a dry surface. We have stated how dry some of our dug soil was to the depth of 2 feet. The other day men were making holes for the posts of a new fence in a meadow, and to the depth of 16 inches the soil was perfectly dry, notwithstanding that the surface was covered with rough herbage. Farther down you could first find traces of moisture, and then enough of it for anything. Now to plant with even moistened balls, and still more with a dibber, in such thoroughly-dried ground would just be labour thrown away. Circumstances thus entirely alter the treatment that should be given. Where there has been plenty of wet weather up to May, planting out in the end of May may be done very differently to what would be required in cases where there has scarcely been a good rain since the beginning of the year. In general, too, on the west coast the atmosphere is more charged with vapour, and there are more passing and frequent showers than in the midland and eastern counties of the island. It used to be said there was scarcely a day without a shower in some parts of the west of Scotland. As the heat and drought of the summer progressed we found a little water at the roots, still more essential at all fresh plantings and sowings. After the very hot days, had we the water we would have been

tempted to have given some of the tenderest things a skiff from the syringe or garden engine, just to refresh the foliage, as what little fell on the heated soil would be quickly raised in vapour, and thus help to give what Nature had refused to give for weeks—a gentle dew. For a couple of months we have rarely had anything worthy of the name of a dewy morning. In the moistest bit of ground we had we turned out strong Cauliflower plants with large balls, and though we shaded them a little, we soon found we would have heads like buttons and spiquing tops if we could not have watered with even dirty water. Personally we feel obliged to Mr. Castle for his pithy article. Extremes often meet. The frequent or every-day watering of plants in the open ground may be led to see that there may be too much of a good thing. The advocate of "no watering" may come to the conclusion that "once watering," or even "judicious watering," does not involve "always watering," and those who are now somewhat bewildered by differences of opinion, may see daylight through their difficulties by remembering that different circumstances as to soil and climate require some difference in management. We have no doubt whatever that many of our friends with water at full command water their plants into disease and dissolution.

Mushrooms—"Anxious," fond of Mushrooms, but hitherto unsuccessful, with a low close shed 18 feet long and 11 feet wide, and having about a bushel and a half of horse droppings every day, with about as much of littery straw, wants to know how to get the most Mushrooms most easily. In such a case, as the beds are to be on the floor, we would divide our space into four equal parts, with a walk of 2 feet or 30 inches down the centre. This would give room for four beds 9 feet long and rather more than 4 feet in width. Our shallowest beds we would have about 12 inches deep in front, and from 15 to 18 inches deep at back. For winter work we would have them a little deeper, and depend on surface covering to keep up the necessary heat. Now, there are many ways of making such beds. We will put ourselves just in the position of "Anxious," and advise him to do as we have frequently done. Collect the droppings with nearly an equal portion of short litter for a week or ten days, and lay them in any place not too thickly, where no rain will fall on them. Then add a barrowload or two of dry soil, mix all together, and make this the base of the 9-foot bed. Beat it firmly together, and it will heat very moderately. Then every second day add the droppings, and the same amount of short, dryish litter all over, tread or beat, and then put a little dry soil over. Continue the process until the necessary height is secured, as referred to above, for the different seasons. By this plan, as will be perceived, the bed will never become very hot, and the bulk of the manure will be fresh—full of nitrogenous matter—and, therefore, capable of carrying a heavy crop of Mushrooms. We have tried many modes, and successfully too, but never one with more success than the above, and it is peculiarly applicable where a bushel or so of droppings can be obtained every day. The success will greatly depend on preventing overheating by the frequent beating and the adding of a little dry earth. Street sweepings or road scrapings when dry are admirable for this purpose. People are slow to learn that fermenting material, as dung, will heat mildly and keep up the heat long in proportion as it is so consolidated as to keep out air, or rather prevent its free entrance. By such a mode the manure is not exhausted as it often is when thrown into a heap and allowed to ferment freely.

If we had the droppings of a single horse and had leisure, the above is the mode we would adopt. Why do you not adopt it now? Just because we could not easily get the droppings regularly, and amidst the multiplicity of matters demanding attention we should not be able to attend to Mushroom-bed-making every day or every other day. Those who try the plan, however, will soon be satisfied that manure cannot be put in the beds too fresh, provided the layers are so thin and compressed that violent heating is avoided. Such beds generally become a mass of spawn, and continue heating a long time. A peculiar treatment, however, has something to do with long bearing. When the beds seem a little exhausted it is well to sweep them clean, and allow the surface to become a little dry. Then, in eight or ten days, make a few small holes over the bed, and give a good watering with water at from 80° to 90°, so that the water will pass down into the manure, pat the bed gently over with the back of a clean spade, cover with clean litter to keep in the heat and moisture, and often in such cases in a week or two you will have a white carpet of Mushrooms.

Much depends on the spawning. Be sure the heat of the bed is on the decline before inserting pieces of spawn about the size of a walnut—if the spawn is good, about 8 inches apart. At spawning, the heat of the bed should be about 80°. If after spawning the heat should seem to fall a little, add from half an inch to an inch of fresh droppings all over the bed, and if the temperature keep all right do not be long in adding, as a covering, from 1 to 2 inches of earth; 1½ is a good medium thickness. When the spawn runs it will make heat enough for itself. To assist it at first, a little covering over the bed is useful, but not so much as to cause the bed to be overheated. The general management has often been given, and in varied circumstances.

The above method is chiefly applicable in cases where it would be desirable to get rid, or nearly so, of all labour in preparing the materials. We speak confidently, because from frequent practice. In fact, other matters attended to, as care of heat at spawning, &c., we are quite sure that the best and the most lasting crops are obtained from beds where the manure used is freshest, and least exhausted by heating previously. The placing thin layers on the bed, and consolidating as you go, keeps up the freshness and prevents exhaustion from overheating at first. We may here add that the materials referred to are the best for Mushroom beds; we have been forced to be content with very inferior material, but we always liked to have a surfacing of such horse droppings, except when we had fermented common dung for the purpose, as used to be done for Cucumber and Melon frames. The half-decayed dung from old beds and linings of Cucumber and Melon frames makes also fine Mushroom beds, either flat, sloping, or on the ridge, if built firmly and a fair depth is given to them. No plan, so far as labour and preparation are concerned, will beat the above where only a small daily supply of material can be obtained.

FRUIT DEPARTMENT.

Mulched a number of our bush and pyramidal fruit trees, to arrest the moist vapour as it rises. We fear even with that help, Apples and Pears, however good they may be, will be small. We would have watered some of them, and wall fruit trees, if we could before this mulching. The ground is in general warm enough now for general purposes, and, therefore, the mulching will do no harm, if it keeps heat and moisture in, though it keeps extra heat out. Early mulching is often injurious, because it keeps the heat of the sun from acting freely on a cold soil. By waiting until the soil is heated, the mulching will be beneficial in dry weather, and if wet comes, the manurial qualities in the mulching will help to entice the roots to the surface. Laid a part of our Strawberry runners in pots intended for forcing, and would have done more, but with us runners are scarce. Strawberries, too, are getting thin. From the first planted-out forced plants we have got a few dishes, and regret we had not more out early, as the later-planted ones have suffered from the drought. Mulched again the pots in the orchard house, chiefly with horse dropping. It is amazing how soon such mulchings disappear, and leave the bare soil of the pots. The mulching greatly saves watering in all such cases. If we see not the chance of rain water, we will mulch the surface soil of these houses, even though we thus keep heat out. We have been obliged to do so with the borders of Peaches and Apricots to within some 4 feet of the wall, to keep them moderately moist, as otherwise the trees would have suffered from dryness. We have our own views as to planting the borders of fruit trees, but we cannot help ourselves; ours are rarely empty, but we generally contrive to have low-growing things on them after the beginning of July, so that the sun may have free access to the trees. For some 4 feet from the wall we like the ground to be uncropped all the autumn, though that, too, is generally well filled in winter and spring. All bad policy in many respects, but when much must be had from little room, many a compromise must be made.

Extended pleasure grounds, and small gardens for vegetables and fruit, are a great mistake. The great part of the expense then goes for what merely pleases the eye, and does nothing whatever to gratify the palate. One gentleman complained to another that "his table was quite as well supplied, and yet you know I keep nearly double the number of men in my garden." Truly replied his host, "But then you have three times the extent of flower garden and mown pleasure ground. That is pretty and gratifying, no doubt, very pleasing to the eye, but it must be paid for. It is like investing a handsome sum in a fine painting, with this difference—that the painting purchased retains its beauty and costs but little more, whilst the flower garden, lawns, &c., during the whole of the pleasant months

are a matter of constant outlay, and are scarcely made nice before they require to be made nice again." Flower beds are bad enough when looked at in a utilitarian point of view, but they are nothing as regards expense when compared with a well-kept lawn. Strange that gentlemen with an eye to the economical—and matters will not be long right if that is not kept in view—will be content with an acre of kitchen garden and care nothing about some three to six times as much of lawn and pleasure grounds. As a practical advice to gardeners we would say, Be always chary in getting additions to your lawn. Recollect that addition will cost you extra work every week, at least all the summer months, and rollings, &c., in winter. A friend of ours, as a matter of improvement, was anxious to add about an acre to the already pretty lawn, and it would have been an improvement. The proprietor at once owned to the improvement, and said the addition could be made at once, but candidly added, "I cannot afford to give you more help, more labour power." The lawn has not yet been enlarged. We believe that now the gardener would rather have a half-acre added to the kitchen garden.

ORNAMENTAL DEPARTMENT.

A good deal has been done in potting Balsams, Coleus, &c., for late work, giving the former large pots and a cool place to keep them stubby. Cinerarias, Primulas have also been potted and pricked off, leaving still plenty of work to do in the overhauling and dividing of Ferns, &c. But the chief work of the week has been *mulching* our flower beds and ribbon borders. The first planted of these, and especially Calceolarias, are pretty full, and so far able to shade themselves. With a watering at planting, and a little help since at long distances, they have otherwise been treated a good deal on Mr. Castle's system, though not to the extent of no watering. A few slight showers, though not telling on the roots, refreshed and filled out the foliage. Of late, however, when the sun was bright they began to show some signs of distress, and therefore we resolved to mulch the beds. We have generally done this less or more every year to save watering, when we were sure that the ground was sufficiently warm to suit even the tenderest of the Pelargoniums. We have been later this season than usual, partly from being scarce of time and suitable material, and partly because the clouds so often promised the rains that did not come, that we were anxious that the beds should have a watering from the heavens before we put the mulching on. But for the Calceolarias being so strong we would have mulched them earlier, as nothing pleases them more than a bright sun overhead and a moist cool soil at the roots. These conditions secured, nothing is more easy to manage. Putting off the mulching so late rendered it impossible in many cases, as in that of Verbenas, closely covering the ground. A little could only be hustled in where there was an opening. For such a purpose anything is better than nothing, but it will always look and answer best when done neatly and with good material. The centres of our largest beds were thinly covered with half-rotted dung and leaves that had been used for Vine borders. This was too damp to pass through an open sieve, but it was nicely broken with the points of a fork so as to be well mixed and made rather fine, put with a shovel into the openings and then spread with the hands. The smaller beds and the outsides of the larger ones were covered over chiefly with old Mushroom beds that were passed through an inch mesh sieve or riddle, and this gives a neatness to the beds when finished. Without any watering from the pail or the clouds this mulching helps the roots by keeping the rising moisture about them, keeps the heat of the sun from penetrating so freely; and the only drawback is, that if we had a succession of warm heavy rains we might have more luxuriance in growth in some things than might be desirable. It is more pleasant, however, to neutralise too vigorous growth by removing some of the larger leaves, than to look on plants at all etiolated and as if they were half starved. All such mulching will soon be out of sight in autumn. We do not mean that the leaves will thoroughly cover it, for that they will do very soon, but the earth and roots together soon take it all away, so that scarce a trace of it will be left. Meanwhile it does its useful work. It takes more time than a good watering, which could only be given now from the surface, and which in such heat would steadily evaporate, but the influence of the mulching will continue until we hope a change of weather comes. When the soil is excessively dry and hot it is well to water before mulching, and mulch immediately before it has the chance of escaping upwards, and this is the plan we have followed generally in the kitchen garden; but in this case, if after mulching we should be forced to water, the water will run

underneath the mulching and get into the soil, whilst the surface of the mulching as a whole will remain dry. These minutiae may be useful where water is scarce. In a kitchen garden rough mulching is all very well, but it should be done neatly in a flower garden.—R. F.

TO CORRESPONDENTS.

. We request that no one will write privately to any of the correspondents of the "Journal of Horticulture, Cottage Gardener, and Country Gentleman." By so doing they are subjected to unjustifiable trouble and expense. All communications should therefore be addressed *solely* to *The Editors of the Journal of Horticulture, &c., 171, Fleet Street, London, E.C.*

N.B.—Many questions must remain unanswered until next week.

Books (*A Constant Reader*).—Hemfrey's "Radiments of Botany." We cannot name plants from leaves only.

FLORIST OR AMATEUR.—*Arpa* asks if a man who grows, advertises, and sells such horticultural flowers as Pelargoniums, Fuchsias, and Cyclamens, ought he to be classed as an amateur at a local show, and allowed to exhibit as such? Yes, if he does not live chiefly on such sales. A gentleman who breeds, advertises, and sells young is not a dealer, but an amateur.

STORING POTATOES (*C. A. G.*).—As you have no shed or other store place, take the Potatoes up immediately the leaves begin to be partially yellow; place the Potatoes singly in alternate layers with earth, and cover the whole a foot deep with earth. Have the heap on the north side of a wall. The tubers will keep without sprouting for years at a temperature of not less than 33° nor more than 55°.

GRUBS ON PEAR LEAVES (*J. T. Y.*).—They are the larvæ of the Pear Saw-fly, *Selandria* a tip-top, and called by gardeners the slimy grub. Dust the leaves thoroughly with fresh-sifted quicklime, and syringe after a day or two. Repeat the process if needed.

SEEDLING PELARGONIUMS (*M. C.*).—Every petal was shed and the box smashed. It is useless to send full-blown Pelargonium flowers, the petals always fall.

ROSEBUSHES OF IRON—"A. Y. Z." wishes to know if anyone can inform him who are the principal makers of rosebushes of light wire material.

HARDY FERNS (*J. N. C.*).—Two dozen distinct and not expensive kinds are:—*Asplenium adnatum*, *Asplenium trichomanes*, *Athyrium filix-femina*, *A. filix-femina plumosa*, *A. filix-femina Frizellii*, *Blechnum spicatum*, *B. spicatum multifidum*, *Cystopteris fragilis*, *Lastrea dilatata*, *L. filix-mas*, *L. filix-mas cristata*, *L. oreopteris*, *Polypodium dryopteris*, *P. phlegopteris*, *P. vulgare*, *Polystichum angulare*, *P. angulare proliferum*, *P. aculeatum*, *P. lonchitis*, *P. alpestre*, *Scelopendrium officinale*, *S. var. multifidum*, *Lastrea recurva*, and *Allosorus crispus*. "The Fern Manual" will suit you. It can be had free by post from our office if you send 5s. 4d. in stamps with your address.

GLOXINIA, ACHIMENES, AND CALADIUM PROPAGATION (*R.*).—*Gloxinia* are readily propagated from leaves or parts of a leaf, but for general propagation it is well to take the whole of the leaf and a part of the leaf-stalk, and insert about an inch of it in a compost of equal parts light loam, sandy peat, and silver sand. They may be put around the sides of a pot, and be placed in a house with a gentle heat, or in a hotbed where they will form bulbs and be good plants the second year. They should be kept moist and shaded from bright sun, and carefully watered. In about six weeks they will be established, and should be continued in a stove until autumn, when gradually withhold water, and keep dry, but not dust dry, over the winter. In February pot off the small bulbs singly, and in small pots, placing in a hotbed. They will give shoots and flowers next year in due course. *Achimenes* are propagated by division, or properly increase of the roots, which are plentiful in most cases after a year's growth, and also by cuttings of the young growths, which strike freely in a hotbed, inserted in sandy soil, as described for *Gloxinia*, and in about three weeks they will be well rooted. Cuttings of *Achimenes* flower well the first year, and do nearly as well as those having a start from the root. *Caladiums* are increased by offsets in spring, they being taken off in spring when the plants are fresh potted. *Gloxinia* and *Achimenes* are cool stove plants, requiring the assistance of a hotbed to start them in the spring, and then a rather shady position, but near the glass, in a stove or vinery. When flowering they do well in a not-too-airy greenhouse or conservatory, being removed back after flowering to a stove to ripen the growth and mature the roots. None of the modes of propagation above named will give new varieties; that must be effected by hybridising and sowing the seed. *Caladiums* require a warm, moist stove for their successful cultivation.

CANNA SEED SOWING (*Item*).—You may now sow the seed of *Canna discolor floribunda* in a hotbed, and keep the plants in a stove during the winter, with the soil inclining to dryness, but it will not be necessary to dry them off like established plants. They will be strong for next year.

TURF BARE UNDER LIME TREES (*One who Likes the Turf*).—The roots of Lime trees are not more injurious to turf than any others; indeed, they are not nearly so bad as Ash. The grass being bare, we have no doubt, is due to the roots of the Limes making the ground poor and dry, the foliage depriving the ground of considerable moisture and light. We should advise you to scratch the surface well with an iron rake, sprinkling on it some very rotten short manure or rich soil, and then sow over it some grass seeds in moist weather, and of kinds that do under trees, as *Poa nemoralis sempervirens* and *Festuca druscula*, and some white Clover. Though September is a good time to sow grass seeds, we should prefer spring, as the ground will then be moist, whilst in September the ground under trees is often little better than dust; but if you have moisture in autumn, by all means sow then. There is no necessity for taking up and relaying the turf every year. A few grass seeds in all that is required.

ORANGE TREES NOT FRUITING (*H. D.*).—Without a greenhouse it is

difficult to grow the fruit to any size; they generally fall, as yours have done in former years, when of the size of peas. The only thing that would cause them to remain and grow to full size is more heat; indeed, to have good fruit a heated house is necessary—a warm greenhouse, in fact, though they do very well in a vinery, yet to have the fruit full-flavoured and juicy they require a temperature in autumn and early winter of not less than 5°. Fruit on trees in a cool house formed this year will not ripen until the end of next summer or autumn.

LILIES OF THE VALLEY (*A Subscriber*).—The plants multi-stemmed flower every year, but they, of course, vary in different years. Sometimes the flowers are more abundant one year than another, but they flower more or less every year. You may secure very good pots by choosing those roots with plump crowns only, and potted pretty closely together they would do well in a gentle heat or in a greenhouse.

COLEUS LOSING COLOUR (*Item*).—We apprehend yours is the *Coleus Verschaffeltii*, and that is losing colour through being kept in a shady position. Keep it in a light position, and put in a compost of two parts fibrous loam, and one part leaf soil or old cow dung, with a free admixture of sharp sand, and good drainage. With that your plants will recover their beautiful dark colour.

DALCHAMPIA ROZELEANA ROSA CULTURAE (*A Constant Reader*).—This is one of the most beautiful plants, and requires but little skill in cultivation. We have it now in a vinery beautiful, with its bright rosy pink bracts contrasting, as they do, well with deep green, graceful, drooping Oak-like foliage. It is seldom or never out of flower, and the plants bloom when a few inches high. It is readily raised from seed, which ripen freely. Sown when ripe in sandy peat and loam, and placed in a hotbed, the plants soon attain to a flowering state. It requires a cool stove, but will do well in a vinery or even a greenhouse in summer; indeed, we think it will do in a warm greenhouse in winter, but not having tried it we cannot say positively. We grow it in a compost of equal parts sandy peat, fibrous loam, and leaf soil, with a free admixture of sand, and afford good drainage. The potting is done in April; that satisfies its wants until autumn, then we again repot, removing what soil we can without interfering much with the roots, and give a moderate shift, and we have flowers all winter. In point of moisture it requires the soil moist, good supplies when the soil becomes dry, and a moist atmosphere. With frequent sprinklings overhead it is at home, but as that interferes with the beauty of its bracts, a moist atmosphere is necessary, as it is rather subject to red spider, but that yields readily to a sponging with a solution of soft soap, 2 ozs. to the gallon. Being very enduring of a dry atmosphere, it is one of the most useful of plants for house-decoration. We cannot name plants from leaves. Specimens with both flowers and foliage are necessary.

PLACING CAMELLIAS AND AZALEAS OUT OF DOORS (*J. B. Boyd*).—It is not desirable to place out of doors *Camellias* and *Azaleas* that have their bloom buds well set, and have been well hardened off; they are best continued under glass in a cool, airy, slightly shaded house, or one with an easterly aspect will answer very well. They are better under glass, for they are secured a greater uniformity of atmosphere. Placed out-doors they have to contend against the change of atmosphere consequent on removal. The weather may be hot, dry, or its opposite—very wet, and the plants are scorched by the heat and dryness in the one case, and excited to a renewal of growth by the other, and before they are housed they have been deluged with wet it may be; anyhow, they cannot be placed out-doors without danger of a check, nor removed in-doors without fear of another, hence we consider them best retained under glass. If placed out-doors at all they should have a position shaded from the mid-day sun, and be carefully attended to with respect to water. They should be housed at the close of September.

TREE FERNS (*Item*).—*Asplenium excelsa*, *Cooperi*, and *australis* will succeed in an ordinary Peach house, but not in that from which frost is not excluded in winter. All do admirably in a vinery; better there than in a Peach house.

EQUISETUM ARVENSE ERADICATION (*E. P. P.*).—From the specimen and later description you give of it we find it is the Corn Horse-tail, and not *E. fluviatile*, as we thought from the former description. It is found on land of a sandy nature or light loam, the subsoil being sand or a layer of that overlying a marly blue clay. The land to all appearance is dry, at least its surface, from its sandy nature, soon becomes dry after rain, but upon examination at a depth of 2 or 4 feet it will be seen that the ground is one spring of water; the drain fills soon from the loose nature of the sand. No land needs draining so much as this. We remember a field that was so poor from the sandy soil, that it was only practical to get Rye and Oat crops off it. It was one mass of Horse-tail every year. The land was drained, would-be *suavis* laughing at the idea. At 3 feet there was plenty of water, and the *Equisetum* roots were lower than that. The result was that the Horse-tails began to grow less every year, and were in a short time reduced to a minimum. The land had a good dressing of manure, the under strata of the same field, and it was sown with Wheat and produced a capital crop—over sixty bushels per acre. We should have said that the drains were only laid 3 feet deep, and with the old horse-shoe tiles with loose, flat bottoms. Though laid on straw in some places, and the tiles covered with that material or loose, small brushwood, the drains soon filled with the sand, and the Horse-tails began to grow thicker and faster. The occupier, by the way, a practical drainer all his life, determined on undoing what he had done, laying-in pipes down into the clay—sequel, death to the *Equisetum*. The land gave better crops, and he soon had offered him land to rent that the farmers would not have. We say, therefore, Well drain the land and the Horse-tails will disappear. They root deeply, require moisture; that taken off, they disappear. Frequent cutting-off the tops will tend to weaken them, but we need to strike at the roots. The drains should be about 21 feet apart, and deep—not less than 3 feet 6 inches; 4 feet and over if you can get an outfall.

ENDURANCE OF STRAWBERRY BEDS—PLANTING (*E. P. P.*).—As lately stated in "Doings of the Last Week," a Strawberry bed will bear well for many years, if the plants are gone over every year, the smaller beds of the plants thinned out, and the best left, and the plants well manured between the rows. By the usual plan of planting and management, from three to four years may be considered a good time to remain. When runners are used they generally produce fairly the first season after planting, very abundantly the second, not quite so good the third, and moderately the fourth. We seldom keep a bed above three years, and that permits rotation of cropping. We are now digging down three-year-

old Strawberry plants, following with Broccoli, &c. The above plan of thinning is useful to those who dislike the bother of making fresh beds, but the ground has not the same rotation. You can rarely obtain all advantages by following out any one mode. Runners should be taken off as soon as you can get them. To make the most of them for a new plantation, it is well to lay them in pots, or encourage them to root in the ground. If not wanted for such purposes, the sooner runners are removed the better, as more light and air will go to the old plants. In forming new beds rotten manure should be used, but if scarce, rank manure may be tramped down, and some rotten manure incorporated with the surface soil to encourage free rooting. The sooner all this is done the better. Whilst this is doing, as recommended to another correspondent, you might prick out your runners in a rich bed to be raised with balls, and afterwards transplanted. When we have been scarce of ground we have used the space intended for a new plantation of Strawberries for autumn and winter crops of vegetables, had the runners pricked out in rich soil, say 4 to 6 inches apart, and having got our ground nicely pulverised in spring, we have lifted our Strawberry plants with nice balls, and they grew away strong at once, and produced a fair crop the first summer. Where ground is of less consequence than a little additional labour, then it is best to plant out at once to where the plants are to remain. We may add that in cold places keeping the plants a little thick in a bed gives them a good protection.

LASTING OF MUSHROOM BED (E. R. P.).—The Mushroom Bed will most likely continue bearing for some time, but it should be covered from the sun with litter as well as a mat, and should not be allowed to get dry. See hints on Mushrooms. Plenty of air will get through a covering, say 3 inches deep. In very hot weather you may sprinkle the covering outside so as to keep the bed cool. Heat in the present and next month is to be kept out, rather than let in. The bed will be of little use for renewing if it heats well. You must make a new bed of fresh materials.

SEEDLING STRAWBERRY DUKE OF EDINBURGH (MOFFAT'S).—This variety received a certificate at the Royal Caledonian Horticultural Society's Meeting on the 13th inst. It is a strong grower, and very prolific, and produces very large cockscomb-shaped fruit. It is a cross between Keen's Seedling and Elton Pine. Some of the berries sent to us were 8 inches in circumference, deep crimson-coloured, and very highly-flavoured.

STRAWBERRY PLANTS FAILING (R. H.).—See the remarks of "R. F." and others in late numbers, so far as sterile plants are concerned. As yours bloomed freely, that could not be the reason. The produce in most places afflicted with the drought has been much less than usual. Our gatherings will soon be over as respects the main crops. The shrivelling-up of the flowers we would attribute to over-ripeness. The turning black of the centres of the flowers we would attribute to frost, and the plants suffered from this in many places. The ground for a new plantation should be got ready at once, trenching two spits deep if the soil is good, incorporating a layer of dung with the lower spit, and when finished pricking-in with a fork another layer—say 2 or 3 inches near the surface. You may plant as soon as you get runners; but if this dry weather lasts, we would advise you to prick out the runners, say 4 inches apart, in a rich bed, and when they had formed a ball of roots, lift and plant with balls in the prepared ground. It will be easier to water and shade a small bed than a large piece.

GARDENERS' ASSISTANT (Inquirer).—We cannot either advise or interfere in a case of such petty differences. Even if you have any claim for expenses, which we doubt, the time and cost of recovering them would purchase them dearly.

INSECTS (E. F. W.).—The eggs on your Rose leaf (from which the young have been hatched during its transit by post), are those of the Brown-tailed moth (*Forthebia caryosoma*). (*H. S.*)—The curious fly found in a window in Bradford, is the *Sirex Gigas*, the larva of which makes cylindrical burrows in Fir trees, often doing much mischief.—*I. O. W.*

NAMES OF PLANTS (Cottager).—The shrub is *Spirea ulmifolia*. We cannot name varieties of florists' flowers. (*J. Bathmaker*).—We cannot name the varieties of florists' flowers. They are in regions.

POULTRY, BEE, AND PIGEON CHRONICLE.

REARING LARGE FOWLS.

The number of dwarf specimens, even of the largest breeds, which are to be seen at any of the poultry shows, is an evidence that the absolute essentials for rearing fine chickens are very imperfectly understood by many who have sufficient interest in the subject to pay for first-rate stock but know not what to do with them. It is not enough to hatch Dorkings, Cochins, or Brahmas of the very best strains, the eggs may be the very best that can be had for money, but if the chickens are not properly treated they will never make fine birds.

With regard to breeding, I am quite certain, after varied experience, that the largest and finest fowls in our climate are produced from chickens hatched between the end of March and the end of April. For Dorkings alone, which grow early and are delicate, the period ought perhaps to be extended to the end of May; but Cochins or Brahmas hatched during that month will not, except in very favourable circumstances, attain great size—at least so great as April birds. March birds are often large, but on the average are inferior to April birds. As to the parents, medium-sized birds are quite as likely to produce large chickens as unusually large specimens. Hens with long backs and legs will generally produce large chickens; and

though this conformation is faulty in itself, if they be mated with short, compact, "dumpy" cockerels or cocks, the result is usually good.

The great essential in feeding is to give a constant and careful supply of soft food. It is here, perhaps, that novices most frequently fail, the opinion that "grit"—*i. e.*, the kernel of the oat—are the only proper food for chickens being about as widely diffused as the idea that peppercorns and rue are good for the "pip," or whatever other ailment a fowl may have. Such feeding gives no trouble, and may answer well for Game or Hamburgs, but it will never rear large birds, for the simple reason that the food is not digested fast enough for rapid growth. Good oatmeal, good sharps, good barleymeal, and ground oats when they can be got—these are the staple food, and must be given not less than every two hours throughout the day till the birds are at least three months old, when the time may be gradually extended till after a few more weeks they have only three allowances of meal and one of dry grain per day. The last feed at night should always be grain; grits or coarse seed at first, and afterwards buckwheat. The latter grain I always find chickens prefer to anything else, but the one meal a day of it is quite enough.

Oatmeal alone is very dry and hard to mix nicely. I also find chickens fledge badly on it. It is better to mix it with crumbled bread, which removes all difficulty, while the birds like it better and eat more. Another great point is, with every meal to get a quantity of fresh grass, cut it into chaff an eighth of an inch long with a pair of shears, and add it plentifully to the food, mixing the whole with milk. The grass will keep the food moist and sweet long after it would be sour without, besides being eagerly relished by the chicks and keeping them in health. I like this plan far better than giving a turf, which may, however, be added, but is not nearly enough green food for them alone. By adding cut grass to every meal without exception, and throwing some down by itself also, chickens may be reared quite as large and in perfect health in a yard 15 feet square as if they had the range of acres. To get the beautiful "condition" of fowls at liberty in such circumstances is indeed impossible, but health and size are within the reach of all.

Milk should be used plentifully, not only mixing every feed with it, but giving the chicks a good drink of it every morning. If, in cold or early seasons, it is slightly warmed all the better; and this morning drink helps them wonderfully, while it will be found both cheaper than, and quite as effectual as, the custard which is sometimes recommended. I need not say that early chickens must be fed at night by candlelight, but April birds do not require it.

Another most valuable adjunct in rearing the large breeds, as I have elsewhere explained in treating on Brahmas, is what is called ground bones or "bone dust," for the knowledge of which, as I have there stated, I was first indebted to my friend Mr. John Stuart, of Helensburgh. I have often found it very difficult to procure, but of its value I can speak without hesitation. It adds both to the eventual size and stamina of the birds, and has a marked effect in postponing their "setting," keeping them raw or leggy, and preventing them in a great degree from getting fat. It appears, in fact, to have nearly all the good effects of forcing with meat without its evils. It should be added in about the proportion of a tea-spoonful to half a pint of meal, and be given thus in every feed from the time the chicks are ten days old. I may just remark that the foetid smell is of no consequence so far as the chickens are concerned; but as the bone dust imparts a most offensive taste to eggs, it should be discontinued before the pullets lay.

At about six weeks old the oatmeal and bread may be discontinued for a mixture of equal parts of sharps, or middlings, and barleymeal, and the grits at night may be exchanged for buckwheat. The milk, grass, and bone dust should be continued, however, and special care be taken that no more be given than is eaten up, so that every two hours the birds may have both fresh appetite and fresh food. If any does remain it must not be left for the chickens to finish, but taken up and thrown to the old fowls. The water, too, must be kept clean and cool, always adding a little sulphate of iron in wet or cold weather. A little camphor kept always in the water is also good.

I think chicks grow faster and do better away from the hen as soon as they are fledged enough, or the weather is warm enough, to keep them from being chilled. In that case care must be taken that until they roost they sleep on very dry ashes or earth, and if the ground be damp their bed of ashes

should be put on a board. Though it has been said already over and over again, it is still needful to repeat, that if large birds are desired the cockerels must be separated from the pullets by the time they are, say, three months old.

To the above feeding a little meat may be added once a-day with advantage, but is not needful. What is needful is, not only to feed well while with the hen, but to continue the same careful, cleanly, liberal, constant feeding till the birds are full grown. Growing chickens cannot be overfed so long as they have only their regular plain diet and eat it with good appetite. It is, perhaps, for this reason that, so far as my knowledge goes, chickens seldom grow so well in an unlimited run as in good grass runs of moderate size.

I have always noticed that my chickens did not grow so well in very hot dry seasons; and though I have never tried it systematically, I believe watering the ground at intervals in hot weather would have a beneficial effect on the birds as well as upon the soil, where the runs are of small size.—L. WRIGHT.

VERMIN IN HEN HOUSE.—My hen house was literally alive with parasites. I procured a packet of N. Howe's preparation from carbolic acid, and the parasites are completely destroyed.—Mrs. THOMAS, *Felmersham, Beds.*

[Carbolic acid may be obtained from any chemist.]

GUILDFORD POULTRY EXHIBITION.

It is very rarely indeed that any committee can boast of so good an entry as took place at Guildford on Friday last, particularly as a first Show. This is, no doubt, well deserved, as the prize schedule was a most liberal one, comprising not only ten pieces of plate, but also the "Poultry Book" and "Pigeon Book," as extra prizes, beyond the money premiums. The County Hall is well adapted for showing specimens to advantage, and had there been a little different arrangement in the disposal of the best positions for light to these classes most requiring it, in lieu of a very extensive "Selling class" monopolising the principal position in the Show, the management would have been faultless.

The *Spanish* proved such a class as can only be rarely met with, and the first-rate condition in which most of them were shown is worthy of the highest praise. The *Grey Dorkings* were not less perfect, and the entry was a large one; but the *White* and the *Black-coloured Dorkings* were very few in number, although a plate prize was offered for the winner of the last-named breed. The *Light Brahma's* were just as good as might fairly be anticipated in this neighbourhood; most of the hens were, however, in very ragged plumage, and altogether out of show trim. The *Gamb* classes were warmly competed for by Messrs. Matthew, Hall, and Laming, with pens of no common character. The chief of these pens were shown in really faultless condition. The *Aylesbury Duck* class was perfection, Mrs. Stamons and Mr. Fowler with extraordinarily fine pens completely throwing into shade all other rivals. The *Rouens* were naturally in the worst of feather. The class for any variety of *Ducks* was decidedly the worst filled in the Show, consequently the first and third prizes were withheld. *Geese* and *Turkeys* also were as well represented as at the very largest of our shows.

To speak too highly of the *Pigeons* is impossible, most of the London fancy being competitors; so good were they that in some classes every pen was highly commended that was left after the selection of the winners. Most of the *Pigeons* were well shown and with perfect fairness. We regretted, however, to find a pen of *Turbits* heavily "trimmed," the beard on one side of the flight feathers having evidently been carefully stripped off to insure favourable appearances in the eyes of the Judges, for it would not affect the powers of flight in this bird at all. On this discovery the pen was, of course, "disqualified." Some well-marked "Spots," and some rather superior *Archangels*, were matters of note in the "Variety class" of *Pigeons*.

The *Silver-Grey Rabbits* were perfection, but the competition in *Lop-eared*, and those for weight, might have been much better.

The weather was as fine as could be wished for, and great numbers of visitors from the metropolis were in attendance.

SPANISH.—1, G. Tonkin. 2, C. Howard. 3 and 4, F. James, Peckham Rye, Surrey. **DOEKINGS.—Coloured.**—Cup, Gun-on & Jefferson. 2, L. Patton, Bishop's Hall, Taunton. 3, F. Parlett, Great Badlow. *hc.* Rev. T. J. Hoysted; C. Pannell. c, M. Putney. **White.**—1, G. Cubitt, M.P. 2 and 3, W. Attkle. **Blue.**—Cup, G. Hine. 2, W. Belcher. **COCHINS.—Cinnamon and Buff.**—Cup, J. Cartell. 2, E. Fearon. 3, J. H. Dawes. **Crava and Partridge-fathered.**—1, J. H. Dawes. 2, F. T. Bilyard. 3, J. K. Fowler, Aylesbury. **White.**—Cup and 2, R. Smalley. 3, A. J. E. Swinell. *hc.* G. Strimling (?). E. Fearon; Mrs. A. Williamson. c, E. Fearon. **BRAMMAS.—Dark.**—1, H. Dowsett, Pleshey, Chelmsford. 2, J. Stalker. 3, F. James. **Light.**—Cup, J. Pares, Postford. 2, A. O. Worthington. 3, F. Croke, Forest Hill. *hc.* Mrs. A. Williamson; H. M. Maynard. c, H. Dowsett; Rev. N. J. Ridley; P. Crowley. **GAME.—Black-breasted and other Bods.**—Cup, R. Hall. 2 and 3, J. Laming. 3, S. Matthew (Duckwing). *hc.* R. Hall; S. Matthew. *Any other Variety.*—1, S. Matthew (Duckwing). 2, J. Laming. 3, C. Havers, Englestone. 3, R. S. Gold or Silver-pencilled.—1, W. K. Tichner. 2, H. Hall (Duckwing). **HAMBOURGERS.**—1, Woodgate. *Gold or Silver-spangled.*—1, Miss C. E. Palmer. 2, J. F. Loversidge. 3, J. Moon. **POLISH (Any variety).**—1, J. Hinton (Silver). 2, T. P. Edwards (White-crested Black). 3, W. H. Patrick. *hc.* E. Fearon. **FRENCH (Any variety).**—Cup, R. B. Wood (Houdans). 2, Rev. N. J. Ridley (La Flèche)

3, W. O. Quibell, Newark (Crève-Coeur). *hc.* J. J. Malden (Crève-Coeur); F. Crowley (Houdans); R. B. Wood (Houdans). **ANY OTHER VARIETY.**—1 and 2, H. W. Vidler (Andalusian). 2, Mrs. Parrell, Stoke Park, Ipswich (Silkie). 3, W. Collier (Black Hamburgs). *hc.* C. F. Montrose (Indian Game). H. J. Godfrey (Black Cochinchina). c, J. Hinton (Malay). 3, J. K. Fowler. **DUCKS.—Aylesbury.**—Cup and 2, Mrs. M. Seamons, Aylesbury. 3, J. K. Fowler. *hc.* J. K. Fowler; Sir H. P. De Bathe, Bart. **ROUEN.**—1, Ivory & Sons. 2, J. K. Fowler. 3, L. Patton. c, M. Putney. *Any other Variety.*—2, J. K. Fowler (Carolina). **GEESE.**—Cup, J. K. Fowler. 2, Mrs. M. Seamons. 3, Sir H. P. De Bathe, Bart. c, J. Pares. **TURKEYS.**—Cup, L. Patton. 2, Rev. N. J. Ridley. 3, Mrs. Messenger. *hc.*—Harrison. **BRAMMAS.—Game.**—Cup, W. Adams. 2, W. B. Jeffries, Ipswich. 3, W. F. Entwistle, Leeds. c, W. B. Jeffries; W. Boulcher; E. S. C. Gibson. *Any other Variety.*—1, S. & R. Ashton, Mottraux (Black). 2, H. M. Maynard (Black). 3, W. Masland (Japanese). **SELLING CLASS.**—1, Miss C. E. Fubny (Gold-spangled Hamburgs). 2, H. Dowsett, Pleshey (Brahmas). 3, J. Smith (Coloured Dorkings). *hc.* H. S. Fraser (Houdans). c, W. Wilby (Andalusian Fowls); F. James (Black Spanish); J. H. Hall (Janitor); Miss M. C. Barnes (Dark Brahma Cock); G. W. How (Guinea Fowl).

PIGEONS.

CARRIERS.—1, H. Yardley, Birmingham. 2 and extra 2, R. Fulton, Deptford. *hc.* J. C. Ord (?). H. M. Maynard; J. Ludkin. **POUTERS.**—1 and 2, R. Fulton. **TEMBLES.**—1 and 2, R. Fulton. *hc.* J. Ford. **FANTAILS.**—1 and 2, H. Yardley. *hc.* C. Bulpin. **BARRAS.**—1, R. Fulton. 2, H. M. Maynard. *hc.* T. Randall. **JACOBINS.**—1, H. M. Maynard. 2, H. Yardley. 3, R. Fulton. **DRAGONS.**—1, C. Bulpin. 2, E. G. Johnson. 3, Philip. **TRUMPERS.**—1, C. Bulpin. 2, H. Yardley. **ANY OTHER VARIETY.**—1, H. Yardley. 2, C. Bulpin. 3, S. A. Wyllie, East Moulsey, Surrey.

RABBITS.—Lopest Ears.—1, G. Johnson. 2, H. Young. **HEAVIEST.**—1 and 2, E. F. Eraby. *Any other Variety.*—1 and 2, S. G. Hudson (Silver-Grey). c, E. E. Eraby (Smiths with Black Ears).

Mr. Hewitt, of Birmingham, and Mr. Tegetmeier, of London, were the Judges.

LEICESTERSHIRE BIRD SHOW.

This was held in the Grand Stand building on the 5th inst. The following prizes were awarded:—

CANARIES.

NEWBORN.—Clear Yellow.—1, Moore & Wynn, Northampton. 2 and 3, S. Tomes, Northampton. c, J. Smith, Leicester. **Green Egg.**—1, Tomes. 2, J. Goske, Leicester. 3, H. Hudson. **Grey.**—c, H. Audley, Leicester; J. W. Hunt, Bovey. **Variogated Yellow.**—1 and 2, Moor & Wynn. 3, S. Tomes. **Variogated Buff.**—1 and 2, Moore & Wynn, Northampton. 2, S. Tomes. c, H. Audley, Leicester; H. Hadley, Thurmaston. **CRESTED.—Buff.**—1, Moore and Wynn. 2 and 3, J. Goske. **Variogated.**—1 and 2, Moore & Wynn. 3 and c, S. Tomes. **BELOANS.—Clear Buff.**—1 and 2, H. Hadley. 3, J. Mason, Leicester. **Variogated Buff.**—1 and 2, H. Hadley. **LEAGUES.—Golden-quilled.**—1 and 2, J. Goske, Leicester. 3, H. Hudson. **Leicester Silver-spangled.**—1, T. Hudson, Bullwell. 2, J. Essex. 3, S. Tomes. **CINNAMON.—Yellow.**—1, Moore & Wynn. 2 and 3, W. Burton, Hackley. c, S. Tomes (?). **Buff.**—1 and 2, S. Tomes. 3 and c, Moore & Wynn. **GOLDENFINK.—Yellow.**—1, T. Cradock, Stanton Wyville. 2, Moore & Wynn. **Buff.**—1 and 2, J. Butt, Leicester. 3, J. Goske. **Extra S.** Moore & Wynn. c, T. Harrison, Stanton Wyville. **TEN CANARIES.**—1, J. Essex. 2, W. Burton. 3, J. Goske. **Extra 3.** J. Mason.

BRITISH BIRDS.

PULPINEER.—1, J. W. Hunt, Bovey. 2, M. Cave, Leicester. **GOLDFINCH.**—1, Mrs. F. Jones, Loughborough. 2, J. Goske. **LINNET.**—1, J. Mason. 2, M. Cave. **SKYLARK.**—1, Master H. Cox, Leicester. 2, M. Cave. **MAPIES.**—1, Master H. Cox.

FOREIGN BIRDS.

CHUCKATO.—1, T. Hopkins, Leicester. **PARROT.—Green.**—1, J. Billington, Leicester. 2, H. Hadley. *Green or any other variety except Green.*—1, Mrs. Duff, Leicester. 2, Burgess, Leicester. 3, R. Gant, Leicester. **Equal 3.** J. Smith, Leicester.

PIGEONS.

TEMBLES.—1 and 2, H. Hadley. **CARRIERS.**—1 and 2, H. Hadley. **POUTERS.**—1 and 2, H. Barshy, Leicester. 2, G. Sturges, Leicester. **RIFTERS.**—1 and 2, H. Hadley. **JACOBINS.**—1 and 3, H. Hadley. 2, G. Sturges. **FANTAILS.**—1, W. Burgess. 2, H. Hadley. **ANY OTHER VARIETY.**—1, H. Hadley. 2, W. Burgess.

JUDGE.—Mr. A. Wilmore, London.

ROSSENDALE AGRICULTURAL SOCIETY'S POULTRY SHOW.

(From a Correspondent.)

This was held at Stacksteads on the 11th inst. There were 152 entries of poultry and 85 of Pigeons. The pens were supplied by Mr. Turner. Many spoke of the excellent arrangements, and to the feeding, &c., of the poultry, and the courtesy of the Committee and Secretaries. Mr. Beldon obtained the challenge cup offered for the most successful exhibitor in the poultry classes. The Show on the whole was pretty satisfactory, and would have been more so but for the disastrous flood which occurred a few days before in the neighbourhood, doing damage to over £100,000, which was the means of seriously crippling the exchequer of the Society. The Society's friends, and the successful exhibitors especially, might be reminded to render some little assistance to the Committee. Their grand stand was completely washed away, besides a very large quantity of boards.

GAME.—1, G. Bagnall, Draycott, Cheadle. 2, C. W. Brierley, Middleton Cock. —1 and 2, C. W. Brierley. **COCKERAL.**—1, T. Dyson, Claytons, Halifax. 2, R. Payne, Brierfield, Burnley. **CHICKENS.**—1, T. Dyson. 2, C. W. Brierley. **DORINGS.**—1, J. Stott, Healey. 2, J. White, Warley. **SPANISH (Black).**—1, H. Beldon, Bingley. 2, C. W. Brierley. **COCHIN-CHINA.—Cinnamon and Buff.**—1 and 2, W. A. Taylor, Manchester. *Any other Variety.*—1, W. A. Taylor. 3, H. Beldon. **BRAMMA Pouter (Any variety).**—1, H. Picketts, Birkdale, Southport. 2, W. Hargreaves, Baccup. **HAMBURGERS.—Golden pencilled.**—1, H. Picketts, jun. 2, Early, Skipton. 3, H. Beldon. **CHICKENS.**—1, H. Picketts, jun. 2, H. Beldon, Bingley. **Golden-spangled.**—1, H. Beldon. 2, H. Picketts, jun. **CHICKENS.**—1, J. Andrew, Waterhouses, Ashton-under-Lyne. 2, E. Brierley, Heywood. **Silver-pencilled.**—1, H. Picketts, jun. 2, H. Beldon. **CHICKENS.**—1, H. Picketts, jun. 2, H. Beldon. **Silver-spangled.**—1, J. Fielding, Newchurch. 2, H. Picketts, jun. **CHICKENS.**—1, H. Picketts, jun. 2, J. Fielding. **Buff.**—1, N. Mark. **DORINGS.**—1, H. W. Hingworth, Healey. **CHICKENS.**—1, J. Cockroft, Hamcliffe. 2, C. Sidgwick, Ryddlesden Hall, Keighley. **BANTAM.—Game.**—1, T. Barker, Hill End. 2, T. Sharples, Forest Bank, Ravenstall. **Game.—Single Cock.**—1, G. Haworth, Helmshore. 3, T. Tattersall, Tunstead Bottoms. *Any other Variety.*—1, J. Walker, Halifax. 2, H. Beldon. **ANY OTHER VARIETY.**—1, H.

Dublin (Polands). 2, J. Watts, King's Heath, Birmingham. SELLING CLASS.—1, F. & C. Haworth, Haslingden. 2, W. A. Taylor, Manchester. DUCKS.—*Aylesbury*.—1, E. Leech, Rochdale. *Rouen*.—1, E. Leech. 2, H. B. Smith, Brooklands, Broughton, Preston. *Any other Variety*.—1, C. W. Brierley. 2, H. B. Smith. *GESE* (Any variety).—1 and 2, E. Leech. TURKEY.—1, E. Leech. 2, C. W. Brierley.

PIGEONS.

CARRIERS.—1 and 2, E. Horner, Haslemere. TUMBLERS.—1 and 2, J. Fielding, jun., Rochdale. BARRS.—1, J. Fielding, jun. 2, E. Horner. OWLS.—1, J. Fielding, jun. 2, J. Hawley, Bingley. POUTERS OR CROPPERS.—1, E. Horner. 2, J. Hawley. FANTAILS.—1, E. Horner. 2, H. Yardley, Birmingham. TRUITS.—1, J. Fielding, jun. 2, H. Yardley. DRAGONS.—1, J. Hawley. 2, J. Watts. TRUMPETERS.—1, E. Horner. 2, J. Hawley. JACOBIANS.—1 and 2, E. Horner. ANTWERPS.—1 and 2, H. Yardley. ANY OTHER VARIETY.—1, E. Horner. 2, H. Yardley.

The Judges were Mr. Fielding, Trentham, and Mr. Dixon, Bradford.

OUNDLE EXHIBITION OF POULTRY AND PIGEONS.

THE entries this year both of poultry and Pigeons at the Oundle Show were remarkably good, and the weather proved most favourable, consequently the success of the Show was unmistakably good. The tent erected for the poultry was large and airy, and the pens supplied by Messrs. Turner, of Shilfield, completed the arrangements in a most satisfactory manner.

One of the best varieties shown were the Grey *Dorkings*. The Game fowls were mostly very superior birds, but many of them were fast falling into bad condition, moulting having commenced somewhat earlier this season than usual amongst most varieties of poultry. The classes of *Cochin* fowls were all good, being decidedly the best ever seen at Oundle. A few good pens of *Hamburghs* were shown, but the entries were few in number. *Bantams* were not so good as those shown last year at this meeting. *Turkeys* and *Ducks* were as fine as could be desired; but the *Geese* were not remarkable in any way.

It is only a rare occurrence that we find a better competition than took place in *Pigeons*. Each exhibitor showed a collection of three pens, the only restriction being, they must be of three different breeds, and this portion of the Exhibition proved most interesting to those nine persons who competed, not an indifferent pen being on view.

The silver cup given by Lord Lilford, for the best pen of poultry of any kind exhibited, was won by the first-prize pen of Spanish hens, closely pressed by the first-prize pen of *Dorking* hens.

DORKINGS.—*Hens*.—1, J. Longland, Grendon. 2 and 3, R. Wood, Clapton, *he*, Rev. E. Barrum, Great Berkhampstead. *Pullets*.—1, J. Longland. 2, H. Yardley, Birmingham. *he*, J. Conkham; J. Watts, Birmingham. *c*, E. Wood. *Cock*.—1, 2, and 3, R. Wood. *Cochins*.—1 and 2, H. Yardley. *GAME*.—*Hens*.—1 and 2, H. Lotan, Oundle. 3, J. Stephens, Walsall. *Pullets*.—1, Green & Sutcliffe, Queensbury, Halifax. 2, H. H. Bletsoe, Ramwell. *Cock*.—1 and 2, S. Deacon, Polebrook Hall. 3, S. W. Smith, Manor House, Fitzharry. *c*, B. Cox, Moulton. *COCKS*.—1 and 2, H. H. Bletsoe, SPANISH. *SPANISH*.—*Hens*.—1 and Cup for best pen in show, J. F. Dixon, Cotgrave, Nottingham. 2, W. R. Bull, Newport, Egnald. 3, H. F. Cooper, Lichfield Street, Walsall. *he*, M. E. Collingwood, Peterborough; J. Stephens, Walsall; E. Smith, Rectory, Oundle. *Cock*.—1, H. F. Cooper. 2, J. Stephens. *he*, W. Bearpark, Auderby Steeple, Northampton; Lady G. Gordon, Orton Hall. *CHICKENS*.—1, W. R. Bull. 2, Lady G. Gordon. 3, M. E. Collingwood. *COCHIN CHICKENS*.—*Hens*.—1, J. W. Binsley, Northampton. 2, J. Stephens. 3, Rev. A. A. Longhurst, Fotheringhay. *he*, J. L. Hilliam, Ormskirk. *c*, W. A. Burnell, Winkburn Hall, Southwell. *he*.—1, W. A. Burnell. 2, J. Stephens. 3, J. A. Binsley. *he*, H. H. Bletsoe; H. Yardley. *c*, W. F. Checkley, Moulton. *CHICKENS*.—1, J. Stephens. 2, H. Yardley. 3, Rev. A. A. Longhurst. *he*, W. F. Checkley. *c*, H. H. Bletsoe; J. Dove, Moulton; W. A. Burnell. *BRAMMAS*.—1, J. Watts. 2, T. Rogers, Walsall. *HAMBURGHS*.—*Gold and Silver-pencilled*.—1, W. Bearpark. 2, Rev. J. Payne, Higham Fevers. 3, J. A. W. Underwood, Warrington. *Gold and Silver-pencilled*.—1, W. Bearpark. 2, J. F. Lovelidge, Newark-on-Trent. 3, J. Stephens. *GAME*.—*Hens*.—1, G. Annis, Clapham. 2, T. Boscawen. *he*, H. H. Bletsoe. 3, Deacon, Polebrook Hall; L. Caldwell, Oundle. *Any other Variety*.—1, E. Worley, Northampton. 2, J. Bead, Oundle. *ANY OTHER VARIETY*.—1, J. N. Easley. 2, E. Goodlife, Conington. SELLING CLASS.—1, S. Deacon. 2, J. Dove, Moulton. *GESE*.—1, E. Goodlife. 2, S. Deacon. *DUCKS*.—*Aylesbury*.—1, J. Dove. 2 and 3, S. Deacon. *he*, E. Goodlife (2). *Rouen*.—1 and 2, R. Wood. *Any other Variety*.—1 and 2, E. Goodlife. *c*, S. Deacon. *TURKEYS*.—1, J. Craig, Fotheringhay. 2, M. Kew, Market Overton, Oakham. *he*, J. A. W. Underwood; J. N. Easley.

PIGEONS.—*Three Pairs*.—1, H. Yardley. 2, J. Watts. *he*, R. F. Trayling, Peterborough; W. Lepper, Northampton.

RABBITS.—*Lap-earred*.—1, S. W. F. and N. Nassington. *Fancy*.—2, J. Clifton, Oundle.

Edward Hewitt, Esq., of Sparkbrook, Birmingham, officiated as Judge.

REPORTS ON RABBITS AT SHOWS.

I HAVE often wondered if better reports on the Rabbit section at shows could not be supplied to "our Journal." I am sure an enlarged and explanatory report of the various points of excellence would be much more satisfactory to the readers generally, and the prize-winners in particular, and not the mere record of prizes as now too frequently seen, and even at times the address of the owner of such prize-winner not fully given. Could not a few words be inserted as to the reason why such specimens received their honours, and some information be given respecting the merits of the whole exhibition of Rabbits? I can assure committeees, judges, and all who are officially connected with such shows, that any report, if not too long, will have space given it, and the report would evidence that some interest was taken in, and nice discrimination brought to bear upon, the merits or defects of the speci-

mens exhibited. Could we not have the number of entries in the various classes given, and any reason stated why this section of the show was attractive, or otherwise, to exhibitors, and a gentle hint to the "powers that be" as to the remedy, if such be requisite? I fancy I hear some one say, "But who is to do it?" Why, who so likely as the judge? or, if his duties prevent him, can no competent admirer be found who could devote an hour or two between each show he visits and the reports appearing in print? We find very intelligent and highly interesting reports from admirers of poultry, Pigeons, and bees. I am sure the hint given will be acted upon and very much appreciated. I promise that each exhibition in my neighbourhood shall have its Rabbits, when exhibited, alluded to if I can possibly find the time to look at them.—HIMALAYAN.

SWARMING.

THE swarming season is generally the most interesting period of the year to apiarians, but it is impossible to predict the hour or even the day when a first swarm will take its departure. If the stores are nearly exhausted, and unfavourable weather set in, no preparations are made for this event; or, if preparations have been made, and young queens are coming forward, the expected swarm not unfrequently delays its exit until the eldest royal lady leaves her cell. When this takes place, the old queen is almost sure to fall a victim to the animosity of the young one, unless the latter happens to be an only daughter. The presence of royal sisters in a hive renders a queen that has just escaped from her cell furious, and in her malignant hatred of maturing rivals she will, without compunction, commit matricide. I have never seen an old queen, when weather or other circumstances would not permit a swarm to make an exodus, destroy the royal cells or their inmates—her offspring. On a few occasions I have seen a top swarm go off just as the successor to the throne was about to obtain her liberty. The reigning sovereign does not appear to be animated by any hostile feeling towards her daughters, and the reason why she lingers in the hive till any of them are matured, and falls a sacrifice, is entirely owing to the bees in not sounding a timely note of alarm, and hurrying her away from a habitation that has become dangerous to dwell in, to some more secure place.

It was in this way I lost my two-year-old wingless matron, which I received from "APICOLA" in March last, and which, with her daughter, had conjunctly occupied one of his hives during the whole of last winter. Though this old queen had permitted her daughter to become a mother and divide the throne, yet her own powers, as far as I could judge, were not impaired in the very least. By the end of the first week of June she had peopled her hive to overflowing, royal cells were tenanted, and all requisite preparations made for swarming. Unfortunately the weather broke, no food was to be obtained from the flowers, and the stock had but a small store of honey laid up. With a temperature seldom above 55° or 56° at its maximum point a swarm was scarcely to be looked for; but whilst swarming was delayed time passed on, and the royal cells matured. On June 20th the eldest princess escaped from her cell, and went piping over the comb. I became concerned for the safety of the old wingless monarch, and forthwith opened the hive to search for her. Amid the vast multitude of bees I failed to find her, but every comb was brooded; some cells contained larvae not larger than pinheads, and I was satisfied that I saw eggs in others. I shut up the hive in the hope that my old favourite might somehow escape destruction; but in this I was disappointed, for not many hours afterwards she was dragged out dead and thrown overboard, having evidently been stung by her rival, which on the day following led forth a swarm.

But whilst using the common phraseology, and speaking of the queen leading forth a swarm, I beg to state my distinct conviction that queens do not lead out swarms, but are led forth by them. On two occasions, at least, I have witnessed in a glass unicombed hive the proceedings that took place immediately before a first swarm made its exodus. From the listlessness and clustering on the lower edge of the comb observable in the early part of the forenoon, it was not difficult to divine that a migration was contemplated. As soon as the day brightened up a few bees hurriedly left the hive, and after a short absence returned, we may suppose, with a favourable report; whereupon two or three bees advanced towards the entrance, and began to emit a series of sharp sounds, almost identical with the shrill notes of distress or anger which bees utter at nightfall as they run out and in at the entrances of their hives when tor-

mented by moths. These sharp sounds in a little while were caught up by other bees, and a troubled movement began, which gradually extended itself. At length the sounds became so merged as to resemble a continuous hiss, and a general running backwards and forwards over the comb followed. In the midst of the commotion the queen for a minute or two remained placid till the tumult became irresistible, and she also began to move. As soon as she was fairly in motion a rush was made towards the entrance, and her majesty, *volens volens*, fairly carried along with the crowd. The like procedure to that now described was noticed on the second occasion as well as on the first, and I have no hesitation in expressing my conviction that queens have very little to say in the matter of swarming, and that it is instinctively initiated by the bees alone when the arrangements within are complete, and circumstances without are favourable.—R. S.

DRIVING BEES.

ABOUT the middle of June last year I had a first swarm of bees. I hived them in a common straw hive, and about the middle of July I found it to be about 10 lbs. weight. The weight of the honey being tempting, and having heard people talk about driving bees, I tried the experiment. I had a man to assist me, and we turned the hive containing the honey and bees upside down (this was about 9 p.m., when the bees were all quiet); we placed an empty hive upon the top, then drew a piece of muslin round the place where the two hives joined, and commenced tapping round the under hive, which made the bees rush into the top one. Still we were uncertain whether the queen had gone up, and, consequently, placed the two hives in that position upon the bee-stand, and took off the muslin, leaving them over the night. The next morning they commenced working as if nothing had happened. In the evening I lifted the top hive to examine, and found the bees were working in it. I allowed them to remain another day in the same position. On the following morning a drizzling rain afforded a very suitable opportunity; I therefore took down the two hives, lifted the top one upon the stand again, and exposed the other to the rain. As a matter of course, the inmates, not liking the rain, fled in hundreds to their new abode. As soon as they all left I took away the hive containing the honey, and the bees continued working in their new home apparently as contented as though nothing had occurred. In the autumn I sold them for 20s., and they were a first-rate standard.

I believe there is no difficulty in driving bees out of one of Neighbour's hives, as described by Mr. Elcome. It is a very interesting process, and one I should greatly recommend, rather than allowing the bees to throw a virgin swarm; it should not be attempted after the middle of July, but earlier if possible, in order to allow the bees time to provide their winter storage.—Jas. GLESSALL, *Old Hall, Mithorp.*

[The objection to the above process is, the enormous quantity of brood which must have been destroyed. This difficulty may, however, be got over by transferring the bees into a moveable-comb hive, and utilising all the worker brood comb, by fitting it into frames in the manner delineated in page 72, of our seventeenth volume.]

HOW LONG ARE QUEENS IN HATCHING, AND WHEN DO THEY COMMENCE EGG-LAYING?

THE perusal of Mr. Pettigrew's recently-published "Handy Book of Bees," has set me observing, and even experimenting upon my own bees, with the view of correcting some of the mistakes which he has made in the natural history of our little favourites—mistakes which I know he is himself most anxious to rectify as soon as sufficient evidence has been adduced to satisfy him that he is really in error.

In the first place, then, Mr. Pettigrew states that "perfect queens are produced on the fourteenth day after eggs have been put into royal cells," whilst a worker is "in the cell twenty-one days," and he calls upon us to marvel at the shortness of time in which queens are in their cradle-cells. Huber, on the other hand, declares that queens occupy the cells sixteen, and worker bees twenty days respectively; whilst Dr. Bevan, who in this respect is followed by most later writers, assigns the same period to queens, but extends that of workers to twenty-one days.

In order, therefore, to determine which of these statements

was correct, I on the 7th of June placed an empty worker-comb in the centre of a populous colony. This comb when removed the next morning, was found to contain a great number of eggs deposited in the cells on both sides, and was then with a honeycomb on either side placed in a nucleus-box, which, having been supplied with a sufficient population of worker bees, was left to the development of royal cells. Three of these accordingly appeared in due time, all on the same side of the brood comb. One was speedily seen to be empty, and, of course, never advanced beyond the rudimentary stage; two were tenanted, and ultimately completed. The morning of the 23rd (sixteen days from the commencement of the experiment) witnessed the birth of a very large and handsome queen, and the remaining royal cell being cut open on the same day, was found to contain only a dead maggot, which had not progressed beyond the larval stage. This experiment conducted just at the height of a very favourable season, would seem to prove conclusively that Huber and Bevan were right in fixing sixteen days as the period required for the evolution of a queen bee, and I may conclude the history of the one in question by stating, that although I watched her with some care, I failed to determine the exact period of her impregnation, but that she commenced egg-laying on the fifteenth day of her age, and is now breeding most profusely.

With regard to the time occupied in the production of workers, I have this season obtained abundant evidence by placing numerous empty combs in the "brood nests" of various hives, and have invariably found that workers commenced hatching out not later than the nineteenth, and in some cases so early as the eighteenth day.

Taken together, these experiments prove that queens occupy only from two to three days less time than workers in coming to perfection, instead of seven days less, as stated by Mr. Pettigrew.

It should, however, be remarked, that although it does not seem possible that these periods can under any circumstances be materially abbreviated, they may, unquestionably, be prolonged in less favourable seasons, since I have myself had a fine queen hatched out so late as the twenty-first day.

Mr. Pettigrew also states that egg-laying "commences from six to ten days after impregnation takes place," whilst Huber and succeeding writers declare that it begins in forty-six hours. During my experience in breeding queens, I have, of course, had very numerous opportunities of observing them either on their actual return from a successful wedding flight, or immediately afterwards, and before the well-known sign of recent fecundation had disappeared, and I may at once state that in every instance I have invariably found that egg-laying commenced on the second day.

After perusing Mr. Pettigrew's book, however, I became desirous of making more exact observation on this point, and have accordingly watched eagerly from time to time during the present summer for evidences of recent fecundation in such young queens as I have reared; but fortune seemed against me, and it was not until about 3 o'clock p.m. on the 8th of this month (July) that I succeeded in detecting the looked-for appearance at the extremity of the abdomen of a young queen then just eight days old. Careful and frequent observations showed that no eggs were laid during the same or the next day, but at half-past eight in the morning of the day following (10th July), the discovery of a couple of eggs placed in cells at some distance apart, proved that oviposition had commenced well within the period of forty-six hours assigned by Huber.

I am satisfied also that Mr. Pettigrew is equally wrong on other points, which unfortunately do not, like the foregoing, admit of being readily put to the test of actual experiment.—A DEVONSHIRE BEE-KEEPER.

LARGE AND SMALL HIVES.

I COMMENCED this year with four hives. No. 1, A small straw skep with a hole at the top, of 1864. No. 2, A S. Swarton with two boxes, of 1865. No. 3, A wooden Woodbury hive, of 1868. No. 4, A straw Woodbury hive of May, 1869, the strongest of the four.

No. 1 commenced work in a super about the 20th of May, and has filled a good-sized glass and two good-sized boxes; but nothing that I could do would induce any of the other three to take to a super till the 8th of July, when the limes came into bloom, and all three took possession of their supers in great force. Up to that day I tried clean comb of last year, and new comb of this year with fresh honey in it, but all was in

vain. My conclusion is that the three hives were too large, and that, unless in very favourable situations, the smaller hive is likely to be more productive than the larger.—H.

NEW BOOK.

Home-made Wines: How to Make and Keep Them. By G. VINE. London: Groombridge & Sons.

This is a useful little book. The following extract will be the best evidence of its contents:—

"The following recipe to make ten gallons of rhubarb wine; or British champagne, will do for unripe grapes with their leaves, tops, and tendrils, currants, gooseberries, and similar sharp fruit, as well as for rhubarb, and will give a general idea of the proper mode of making a brisk wine. The time of fermenting, quantity of fruit, &c., must be modified somewhat in each case to suit the peculiarities of each fruit; for which directions will be given under their respective heads.

"Provide a fermenting tub that will hold from 15 to 20 gallons, or larger if required. It should have a guard or rim on the inside, similar to that used for brewing; beer, in order to keep back the husks of the fruit, and a tap near the bottom.

"Take 50 lbs. of rhubarb, and 37 lbs. of fine moist sugar. In the tub bruise the rhubarb; when done, add four gallons of water; let the whole be well stirred together; cover the tub with a cloth or blanket, and let the pulp stand for twenty-four hours; then draw off the liquor through the tap into another tub or pan; add one or two more gallons of water to the pulp, let it be well stirred, then allowed to remain an hour or two to settle, and then draw off; mix the two liquors together, and in it dissolve the sugar.

"Let the tub be made clean, and return the liquor to it, cover it with a blanket, and place it in a room, the temperature of which is not below 60° of Fahrenheit's thermometer; here it is to remain for twenty-four, forty-eight, or more hours, until there is an appearance of fermentation having begun, when it should be drawn off into a ten-gallon cask, as fine as possible, which cask must be filled up to the bung-hole with water, if there is not liquor enough; let it lean to one side a little, that it may discharge itself; if there is any liquor left in the tub not quite fine, pass it through flannel, and fill up with that instead of water. As the fermentation proceeds, and the liquor diminishes, it must be filled up daily, to encourage the fermentation, for ten or twelve days; it then becomes more moderate, when the bung should be put in, and a gimlet-hole made at the side of it, fitted with a spile; this spile should be taken out every two or three days, according to the state of the fermentation, for eight or ten days to allow some of the carbonic acid gas to escape. When this state is passed, the cask may be kept full by pouring a little liquor in at the vent-hole once a-week or ten days, for three or four weeks. This operation is performed at long intervals, of a month or more, till the end of December, when, on a fine frosty day, it should be drawn off from the lees as fine as possible; the turbid or muddy part passed through flannel. Make the cask clean, return the liquor to it, with one drachm of pure isinglass dissolved in a little water; stir the whole together, and put the bung in firmly. Choose a clear dry day in March for bottling. They should be champagne bottles—common wine bottles are not strong enough—secure the corks in a proper manner with wire, &c. The liquor is generally made up to two or three pints over the ten gallons, which is bottled for the purpose of filling the cask as it is wanted.

"To make a dry wine like sherry from the same kind of fruit, the cask must be kept constantly filled up to the bung-hole, daily, or every other day, as long as any fermentation is perceptible by applying the ear to the bung-hole; the bung may then be put in lightly for a time, before finally fixing it; it may be racked off on a fine day in December, and fined with isinglass as previously directed, and bottled in March."

OUR LETTER BOX.

FEEDING COCHIN-CHINAS (An Amateur).—Your food is not good enough. Do away with the pollard and Indian meal. Feed on ground oats, good heavy barley, a little Indian corn now and then for a change, and table scraps of every kind, crumbs of bread, &c. We are not friendly to any artificial food.

POULTRY-YARD ARRANGEMENTS (Constant Reader).—As a rule where fowls are kept no other poultry should be kept with them. The same management with your Turkeys probably has the same result. The hen is let loose too soon in the care of the chickens, or the hour of the day. A hen Turkey should not be at liberty till the poulters are seven or eight weeks old, and when that time has arrived she should not be at liberty till 10 A.M., when the sun is well up, and the grass is dry. Separate the Turkeys from the fowls; give the sickly ones green onion tops chopped fine, and mixed with meal, give them two pills of camphor daily, the size of horsebeans, and let their water be strongly impregnated with the same. If they are sinking you must give them some strong beer. We can only tell you how to combat the disease. If you tell us how you treat your birds, we will do our best to advise how to prevent it.

CHICKENS DYING WHOLESALVE (A Lover of Poultry).—Try some other plan of feeding. Either Mr. Wright's disagrees with them, or they get something besides his bill of fare. Do the yew trees drop any berries? If they do not, then the chickens get at something at times that is highly injurious, and causes these periodical and fatal attacks. We feed on bread and milk, chopped egg, crumbled bread and cheese curd, and

chopped scraps of meat. We give them beer to drink while they are not more than a month old, and we lose none.

HOUDAN CHICKENS ALMOST FEATHERLESS (J. H. C.).—Again let us observe that the best food is the cheapest. Sharps, fourths, middlings, bran, "chicken food," and all such appliances are as good for the chickens as a handful of sawdust each would be for a large family where the meat would not hold out. Adopt the dietary we have mentioned in our last answer. Wash the chicken that is suffering from inflammation with warm water and soap, dry it thoroughly, and then rub it with sulphur ointment. Your maggot-feeding probably helps to produce the disorder which arises from a heated system.

HOUDAN HEN HAVING A BROOD (Frances Anne).—We have never had a broody Houdan, but there is no rule without an exception, and we have known both Pencilled Hamburgs and Spanish to sit, and fulfil all the subsequent duties in a most satisfactory manner, as your Houdan hen is doing.

SNATH SHOW.—Messrs. Newbitt send the following as a correction of our prize list:—Spanish, first, H. Beldon; second, T. C. & E. Newbitt; third, C. W. Brierley. Jacobins, first and second, T. C. & E. Newbitt.

ANTS IN A HIVE (Miss P.).—The ascent of ants to a hive of bees may be prevented by nailing round the pedestal, a short distance from the ground, a bit of sheepskin with the wool outwards, and anointed with coal tar.

DWINDLED STOCK (A. O. L.).—Your stock has most probably dwindled owing to the death of its queen during the winter, and can now only be restored to prosperity by adding to it a new swarm.

BEEES IN AN OLD HIVE (A Sub.).—If you had expelled the remaining bees by driving at the oxidation of three weeks from the issue of the first swarm, little or no brood would have been found in the hive; whereas, at this time there is probably a considerable quantity. You may, however, now transfer them, combs and all, to a frame hive in the manner described in page 72 of our seventeenth volume, or you may drive and unite them to another stock in the autumn.

METEOROLOGICAL OBSERVATIONS

In the Suburbs of London for the week ending July 19th.

Table with columns: DATE, BAROMETER (Max., Min.), THERMOMETER (Air: Max., Min.; Earth: 1 ft., 2 ft.), Wind, Rain. Data for Wed. 13 to Tues. 19, and a Mean row.

- 13.—Overcast but fine; showery; clear and fine.
14.—Fine, cloudy; very fine; clear and very fine.
15.—Very fine; exceedingly fine and hot; fine.
16.—Very fine; fine, heavy clouds; clear.
17.—Very fine; cloudy, fine; densely overcast.
18.—Overcast; densely overcast; heavy clouds.
19.—Fine but overcast; fine; very fine and clear.

COVENT GARDEN MARKET.—JULY 20.

A VERY steady demand, and fair prices are realised for most of the goods now coming. Continental and Channel Island supplies continue heavy, and share the demand. Among the former are Peaches, Nuts, Apricots, Melons, Pears, and Apples. Potato trade is easier.

FRUIT.

Table listing prices for various fruits like Apples, Apricots, Cherries, Currants, Blackberries, Figs, Filberts, Cobs, Gooseberries, Grapes, Lemons, Melons, Mulberries, Nectarines, Oranges, Peaches, Pears, Pine Apples, Plums, Quinces, Raspberries, Strawberries, Walnuts.

VEGETABLES.

Table listing prices for various vegetables like Artichokes, Asparagus, Beans, Broad, Beet, Broccoli, Brussels Sprouts, Cabbage, Capsicums, Carrots, Cauliflower, Celery, Coleworts, Cucumbers, Pickling, Endive, Fennel, Garlic, Herbs, Horseradish, Leeks, Lettuce, Mushrooms, Mustard & Cress, Onions, Parsley, Parsnips, Peas, Potatoes, Kidney, Radishes, Rhubarb, Savoy, Sea-kale, Shallots, Spinach, Tomatoes, Turnips, Vegetable Marrows.

WEEKLY CALENDAR.

Day of Month	Day of Week.	JULY 28—AUGUST 3, 1870.	Average Temperature near London.			Rain in last 43 years.		Sun Rises.		Sun Sets.		Moon Rises.		Moon Sets.		Moon's Age.	Clock before Sun.	Day of Year.
			Day.	Night.	Mean.	Days.	m.	h.	m.	h.	m.	h.	m.	h.	Days.	m.	a.	
28	Th	Lee and Blackheath Horticultural Show.	76.4	50.8	63.6	21	19	4	51	af	7	0	af	4	10	af	8	200
29	F		75.5	49.9	62.7	18	21	4	50	7	11	5	44	8	1	6	13	210
30	S		75.2	50.2	62.7	16	23	4	49	7	27	6	42	9	2	6	10	211
31	SUN	7 SUNDAY AFTER TRINITY.	74.9	50.0	62.4	15	24	4	47	7	44	7	35	9	3	6	7	212
1	M	Lammas Day.	75.6	50.4	63.0	19	25	4	46	7	4	9	0	10	4	6	1	213
2	TU	Royal Horticultural Society, Fruit, Floral, and General Meeting.	75.3	50.9	63.1	20	26	4	44	7	23	10	23	10	5	6	1	214
3	W		74.9	50.6	62.8	19	28	4	42	7	43	11	45	10	6	5	56	215

From observations taken near London during the last forty-three years, the average day temperature of the week is 75.4°, and its night temperature 50.4°. The greatest heat was 92°, on the 2nd, 1856; and the lowest cold 31°, on the 2nd, 1864. The greatest fall of rain was 1.39 inch.

CULTIVATION OF THE STRAWBERRY IN THE OPEN GROUND.



HAVING been for some years successful in the cultivation of the Strawberry out of doors, I will give the mode I adopt, by which a good crop is obtained every year almost with certainty. I shall first describe the way in which I grow the plants in the open ground without any protection; then the mode in which I have grown them in the open ground with protection, to forward the early crop.

I will, however, in the first place offer a few hints that will be found necessary to success. Never keep a barren plant; go over the rows as soon as they are well in bloom, and pull out all such plants. I am persuaded there are many failures from omitting to do this. Never dig amongst the plants, nor cut off the leaves at any time. If we wish to grow the Strawberry well we must bestow some attention on it; if it is cultivated on the starvation system of remaining three, four, or five years on the ground, how can one expect fine fruit? if every year a good crop can be produced of fruit fit for any table, either private or exhibition, by bestowing no more care than, if so much as, will have to be done to get a crop of good Celery, I think it is worth the trouble. I have this year gathered many fruit from British Queen, Lucas, Dr. Hogg, and President from 4 to 5½ inches in circumference off plants put out last September, many of these young plants producing from 1 to 1½ lb. the first year, and very heavy crops the second, though the fruit is then never so fine as on the young plants. Some sorts, such as Wizard of the North and Black Prince, I never again intend to cultivate longer than one year, for the quality of fruit from the young plants is much superior, many of the berries of Black Prince being 3 inches in circumference.

I will first describe the mode of taking the runners. Having at this time of year plenty of empty pots out of which bedding plants have been turned, I have as many washed clean as I require; any size from 3 to 5 inches in diameter will do. I then mix about equal parts of rotten dung (generally from an old Mushroom bed) and loam; this mixture is put through an inch sieve, and the rough part is used for crocking. The soil is pressed into the pots rather firmly, and a small peg, cut from old birch brooms during the winter, put into each pot: the pots are then watered, carried to the rows, and a runner pegged into each, generally the first runner from the plant. If the weather is dry they are watered a few times with a rose-watering pot, and the runners will be rooted in from twelve to sixteen days. I have 1100 that were layered on June 27th and 28th, taken off rooted on July 13th. They are then set on a hard walk in the full sun, each sort by itself, till the ground is at liberty for planting, which is often not till late in September.

The plants are then planted thus:—Supposing the ground has borne a crop of Onions or Peas, the usual way would be to trench it over, instead of which I dig out a

trench the depth of a spade and as wide, as for Celery; I put in 3 or 4 inches of good dung, return the soil, and tread it quite hard. I treat all the rows the same, making them 2 feet from each other, till I have as many rows as I require. The plants when turned out of the pots have a mass of roots, and are planted with a trowel at 18 inches apart in the rows, not making the hole too large, and are pressed in very firmly. If the weather is dry they are watered, otherwise they seldom have any water during the time they are on the ground. During the winter they are mulched with rotten dung from an old hotbed, if it can be spared—the two-year plants always.

I plant every year about half the plants intended to produce the main crop, say from 100 to 150 square yards, so that if one part of the bed should fail I never miss having a crop. For the last three hot summers the berries have been splendid; this I attribute to the firmness of the ground and the depth the roots go down. The hoe is used once or twice in spring to cut down weeds and to keep the fruit free from soil, &c., and a layer of clean straw is put between the rows just as the plants begin to show their flower stalks. After I have secured the runners I require, the rest are cut off, and cleared off along with the straw from the young plants; the other plants are done away with. No digging nor cutting off leaves is practised. I do not find any injurious effects arising from the runners being allowed to remain while the plants are fruiting, as I have taken as many as a dozen this year from young plants which have borne equally well with those which had the runners cut off.

I will now describe the mode of cultivating the Strawberry in the open ground, with protection to forward the early crop, by which this year I was enabled to ripen a good crop three weeks before the main crop was ready for use. Wanting some Strawberries last year early in June, and not having any plants in pots, I covered part of a bed of two-year-old plants with lights used for Vine and Peach borders during the winter. The plants did so well that I determined to make a bed specially for this year. The plants were turned out of pots late in September in ground that had borne a crop of Onions, a dressing of dung being trenched in, and at only 1 foot apart each way. I could not plant in trenches. They had a top-dressing of rotten dung about November, and were covered with lights on the 7th of March. The lights are 7 feet 9 inches long by 3 feet 6 inches wide, covering fourteen rows of plants, and forming a span-roof 15 feet wide, and 15 inches high in the centre.

It is a very simple affair, not taking more than an hour to construct; there are a few pegs driven into the ground, leaving them 15 inches clear above it; then some boards, 9 inches wide, which are used for shelves during the winter, are fastened to the pegs with two or three nails, and form the ridge. The bed slopes from north to south. The lights are put on the east side first, resting on the ridge, and those on the west side resting on them. A piece of slate is put under the ends of the lights to keep them off the ground, and a short peg is put in to keep them from shifting. Some thin boards are put to each end, not by

any means closely, and there is a span-roof 30 feet by 15 made in an hour. By varying the length of the pegs, it could be made higher if required.

The bed was made close to a walk 6 feet wide, so that in showery weather the lights could be taken off, which was done three or four times during April; they could be taken off and piled on the walk in less than five minutes by two men, and put on in the same time. I know well enough many gardeners are not so fortunate as to have lights to spare for a purpose of the kind. Were I to have the choice of the various patent plant-protectors, about which so much has been said, I should still prefer glass lights. These lights, of which there are upwards of seventy for covering Vine and Peach borders, answer extremely well for Vegetable Marrows and Tomatoes, by driving into the ground two stakes, such as are used for Dahlias, and resting two lights against them, as a child who was about to build a house of cards would do. Then rest each light on two bricks laid flat, and drive down a peg to each light to prevent its slipping off the bricks. Of course, the plants are put in first, four under each epan. By these means I secure an abundance of Vegetable Marrows and Tomatoes. The latter have plenty of fruit, some just showing colour, and the Vegetable Marrows I commenced to eat in the last week in June.

To return to the Strawberries. The lights were elevated on bricks laid flat as the plants began to grow and show flower, after another week they were put on edge, and by the time the plants were in full bloom they were put on end, two lights resting on one brick. The lights were entirely removed by the 15th of May. I only used twenty bricks, as there were eighteen lights. A few fruit were ripe during the last two days of May, and I gathered from the bed up to June 30th, 92½ lbs. of good fruit, some of Lucas 5 inches in circumference. I have since gathered 8½ lbs., making 101 lbs. There must have been fully 5 lbs. lost by birds and damp. The bed was never netted, and after the main crop was ready, which was June 25th, little notice was taken of the bed. The smallest quantity gathered at one time was half a pound. June 15th, 8½ lbs.; June 18th, 7½ lbs.; and June 21st, 15 lbs., were the largest quantities at one time. The sorts grown were—Black Prince, four rows; Filbert Pine, four rows; President, two rows; British Queen, one row; Lucas, one row; La Constante, one row; and Rivers's Eliza, one row. This was an experimental bed. The bed I am about to plant for early next year will consist of four rows of Filbert Pine, four of President, four of Lucas, two of Black Prince, and another of Dr. Hogg, British Queen, and President, with, perhaps, two rows of Lucas. This will be covered a month later than the first bed, which I hope to gather from by the middle of next May.

I will now add a few remarks respecting varieties, but only as regards my own experience, as they differ so much according to soil, situation, &c. I shall first name Lucas, President, Dr. Hogg, and Cockscomb. These four I procured two years ago next September, owing to the Rev. W. F. Radclyffe's having spoken so highly of them in the Journal. When I received the runners, fifty of each sort, they were very small and got beautifully less, till by spring I had only seven plants of Dr. Hogg, and not many of any of the others. I only had a few fruit last year, making runners the chief point. I obtained a good number of Dr. Hogg, many from President and Lucas, but Cockscomb was very shy, as it is this year also. Lucas has succeeded very well indeed under glass, the fruit being very large, fine-flavoured, and early, as it likewise was out of doors. It has one fault at present, which I hope to get rid of next year—I have had to pull out one-fifth of the plants on account of their being barren. President has proved a first-rate cropper, very large, of good flavour, and with no barren plants. Dr. Hogg has been very fine, producing many fruit, very large, and of first-rate flavour, but it has not borne so heavily as British Queen does on what might be called the trench system. Cockscomb I do not think so fine-flavoured as either of the others. With me it is not in full work yet, nearly half the plants I had being not true or barren. The largest fruit I had from it was 5½ inches in circumference. It is late. In addition to the above I have British Queen, Wonderful, Wizard of the North, Filbert Pine, Black Prince, Sir Charles Napier, La Constante, and Rivers's Eliza. British Queen is the best flavoured of the lot, produces splendid fruit and plenty of it, especially on the young plants. Berries 5½ inches in circumference are the largest I have had from it, but there were many of that size. Wonderful is a good cropper, many of the fruit being very large, particularly on the young plants. It does best in a wet season, and is of good flavour. Wizard of the North is a cer-

tain cropper; many of the plants planted last September must have borne more than a pound of fruit. It would take the place of Black Prince for kitchen purposes; the fruit is much finer, has a peculiar flavour, and is rather acid. Black Prince is too well known to need description, and is a sure cropper. Filbert Pine cannot be spoken of too highly; it comes into bearing as soon as Black Prince, is as prolific, continues bearing longer, and many of the fruit are very large; it is of first-rate flavour, and a certain cropper. I have grown it eight or nine years, and never knew it fail to produce a good crop; it is very robust, and makes plenty of runners. With it I superseded Keens' Seedling two years since, as it is in every respect superior to that well-known sort. La Constante, I think, is not true with me; the fruit is not large, as I sometimes hear of its being; it is only second-rate as regards crop, but is good flavoured. It did tolerably well under glass. Rivers's Eliza has never succeeded well here; I am doubtful if it is true. I shall only keep it another season if it do not improve. I am loath to part with it, as I see it is spoken very highly of at times. Sir Charles Napier is bearing well this year; it has been very barren. It is valuable for its lateness, only just coming into use; it is much like British Queen, but more acid. Sir Harry I grew two or three years, I could get nothing but leaves from it, and I have discarded it.—J. T. CREECH, Gardener to F. Swanwick, Esq., Whittington House, near Chesterfield.

AMONG THE SHOW ROSES.

GLAD WAS I WHEN

"The storms of wintry time had passed,
And one unbounded spring encircled all,"

For I purposed, though with fear and trembling, that the next Birmingham Exhibition of Roses should find me an exhibitor, and I knew that nothing but the hardest work and the closest attention would bring me the glory of success; and who would not strive for success in such a cause? So with a right good will I set my rosery in order, removed all superfluous wood, turned over all the soil, pruned where I thought the knife was needed, and, above all, manured heavily with thoroughly decayed horse dung. How I watched with growing anxiety day after day for the dreaded east wind, which, I gratefully add, never came, or came so lightly as to do no damage! How I looked forward with apprehension for the storms which usually visit our neighbourhood with levelling power each spring, and they also did not come! Then an anxious period, when the grubs were expected, and though they sprang into existence like magic, yet almost as suddenly did they disappear.

So far all was inspiring—no blighting winds scorching the foliage, no gales tearing the leaves from the wood and the wood from the stem; no insects to check the healthy growth of buds and foliage. From the beginning, therefore, until the drought checked the growth and forced the buds, circumstances stimulated me to labour with a cheerful heart from "early morn to dewy eve." But I had bedding stock to attend to as well as Roses, and my business likewise. So I overstrained my powers and fell sick. To recruit I went into Yorkshire, and then came the tropical heat of the latter part of June, filling me with anxiety about my Roses, as I feared they would be prematurely forced into flower. When I returned home ten days before the show, to my chagrin I found the Roses in full bloom—a heavy disappointment; it seemed that all my time and labour had been thrown away, for had I not trained for a race I could not enter? However, course soon revived when the glorious rain came, soaking deeply into the earth, and fresh buds made their appearance everywhere.

Our show was on Thursday, July 7th, and the Tuesday preceding it was a day which Mark Tapley might have pronounced jolly, but to me it was simply and downright miserable. The rain came down steadily and persistently for twelve hours, spoiling nearly all the expanded blooms upon which I was reckoning, besides spoiling my Moss hurt, which I had promised myself should be a kind of happy prelude to the show.

Well, I wandered through Satten Park till drenched to the skin, but I obtained a stock of pretty, compact Moss. The next day was hot and clear, and the rapidity with which buds expanded was marvellous. The eve of the show was spent in arranging the boxes, getting ready the labels, and taking careful stock of the best blooms.

The morning of the show, and of my first competition, I shall never forget. The days of my boyhood were back again with all their freshness and delight. The rising sun was

surely brighter, the air purer, the dew fresher than ever before, and, as I looked around me, beauty everywhere, and peace in my heart, I could not help repeating those exquisite lines of Wordsworth—

"God made the flowers to beautify
The earth, and cheer man's careful mood;
And he is happier who hath power
To gather wisdom from a flower,
And wake his heart in every hour
To pleasant gratitude."

But this is by the way. The business of the hour was to cut the best twenty-four Roses. That Rose which the Rev. S. Reynolda Hole says "is looking in at the window in every condition of life," was soon at my side deciding as to the merits of this bloom and that bloom, this combination of colours and that, and by 7 A.M. we had placed the better twelve blooms in one box, and the worse twelve in another. I thought it better to concentrate my strength in this manner rather than make each box equal, and the result proved I was right. Nearly all the Roses in my boxes had opened within thirty hours of my plucking them; they had, consequently, one very good quality—freshness. Friend Spencer (an enthusiastic roserian, for whom, by-the-by, a name-machine should be invented, for he can never remember the name of a Rose), popped over to see the boxes before they were closed, and he bade me be of good cheer. Then came the hasty breakfast, the short run by train to Birmingham, and for the first time I was elbowing the heroes of a hundred fights. Talk about the exhilarating, glorious vintage of Champagne! Why, I felt more exhilaration, of a pure and enduring nature, too, than could have been produced by the choicest champagne that ever was raised in *la belle France*. Alas, that she should have since let slip the dogs of war!

At 10.30 the Hall was cleared for the judges, and at 12 we were again admitted. Need I say that a rush, decorous as possible, but still an unmistakable rush, was made for the stand, and that my cup of joy was filled to overflowing when I gazed upon the card which announced that my Roses had gained a *first prize*! No wonder that for the remainder of the day the burden of my song was—

"What is fairer than a Rose?
What is sweeter?"

—C. W. M., *Wylie Green*.

THE BALSAM.

I AM very glad to see that in several gardens the old love for the Balsam is being rapidly revived. Gardeners find out that in order to get up a good floral display with as little trouble as possible the Balsam is one of the best plants they can grow. I find it is as useful as ever, and I think there are few things easier grown, or that will reward the cultivator with so much bloom according to the trouble of growing them. It is quite a summer and autumn decorative plant, and its cultivation is most conveniently commenced when bedding plants are cleared out.

The best plants I ever grew were nearly 4 feet high and some of them 3 feet through, and fully bloomed from bottom to top. The following was the treatment given:—The seed was sown in thumb-pots during the first week in May, two seeds in the centre of each pot in light sandy soil, and placed in a Melon frame at work. When up and the seed-leaves well developed, the weakest plant was taken away, and the other shifted into 60-sized or 3-inch pots; they were plunged and kept near the glass. Their next shift was into 48-sized or 5-inch pots; but while they were growing to this stage, preparations were being made for them to occupy a place to themselves—namely, a heap of spent hotbed and green manure in equal parts thrown together, well mixed, and heated almost to a blackness; a bed 3 feet high at back and 2 feet in front, and long enough to take six lights, or two three-light garden frames, was made up, the inside of the frames filled up to within a foot of the glass with decayed leaves, and when the whole became warm the plants were plunged into it, and in these places they were grown until they were coming into bloom, when they were taken into more airy quarters for their buds to open. In the early part of the time they are growing in these places an intermediate temperature must be maintained; give the plants plenty of light, at all times keep them near the glass, shift them into larger pots as they require it, and give them a rich soil composed of equal parts of turfy loam and rotten manure, with sand added, using the soil coarse as the plants increase in size.

In potting, let the plants down into the pots, so that the cotyledons, or seed leaves, shall be level with the soil. Attend well to watering, of which, when growing, the plants like an abundant supply and often, likewise sprinkling the foliage to keep the red spider in check. Turn the plants at regular intervals to keep the shoots equally balanced and the plants of good shape. If the plants do well they will throw out strong side shoots, and these in turn will throw out laterals. The first-named should be tied or pegged down as low as possible, and the latter kept properly staked-out, which will add much to the beauty of the plants. They will all flower. As the plants increase in size and height, the frames must be hoisted on blocks of wood or on bricks, and the air that is thus admitted under the plants will keep the foliage of the lower branches both strong and healthy. 16-sized or 8-inch pots will grow very fine plants, but 12's or even 8-sized pots may be used when extra-sized plants are wanted.

Soon after the last shift, or when the pots are filled with roots, a liberal top-dressing of rich manure should be given. In this the side branches will root vigorously, and if manure water be regularly applied, the plants will fully develop themselves. It is my practice, and I can recommend it, to pull off regularly the largest flower buds until every branch is regularly furnished with them; then let them flower, and the result will be such a mass of bloom as will, perhaps, surprise the cultivator himself.

After the plants have attained their full size and the pots are full of roots, water must be given most carefully, especially manure water; for if the soil becomes too wet, or the water not able to pass freely through the drainage, the plants are liable to rot off at the neck suddenly. It is now so easy to get seed that will produce a good percentage of double flowers that the old plan of proving the flower by first limiting the plants to small pots may be dispensed with. I generally grow Smith's packet of nine colours.—THOMAS RECORD, *Lillesden*.

MYOSOTIS DISSITIFLORA AND OTHER FORGET-ME-NOTS.

SOME discussion took place last year on the respective merits of *Myosotis dissitiflora* and others for spring decoration, the admirers of *M. dissitiflora* extolling it in terms which may fairly invite criticism, if it should fail to satisfy those who secured the plant for this season. I think those dissatisfied with it must be rather numerous, as the past winter has not been so favourable for plants of this class as the previous one; but the question arises, Has not this Forget-me-not been overpraised? In the few instances in which it is said to have done well, it has failed to meet the requirement it was expected to satisfy, "earliness of blooming," for it certainly has no advantage in this respect over another Forget-me-not that has been long known in this neighbourhood. Neither is it at any time, so far as I have observed, so pretty; the pink tinge of the early flower of *M. dissitiflora* in its early blooms is a disadvantage. Besides, it never forms such a neat, compact corymb as the common species, if I may so call the other, which, I may remark, seeds and grows freely enough, and its bloom forms a much neater auxiliary to the bouquet-maker than that of *M. dissitiflora*. In my own case, I must say I am disappointed with it, as I gave the plants I had the best position, and yet they did not flower so early as the common Forget-me-not, and at first the dirty pinkish hue was anything but agreeable. Latterly the flowers have improved in colour, and individually the pipes or blooms are a trifle larger than those of the common Forget-me-not, but, as before stated, too loose and disconnected to form a neat, compact head, and, taken individually, the petals or limbs of the corolla have too starchy an appearance, with less of that neatness which forms the principal charm of the Forget-me-not.

Other growers may be more successful than I have been, or it may have succeeded better in some places than here; but as I have not heard of any, and, besides, have heard of several failures, the inference would appear that it has been overpraised, as many useful things have been before it. Witness the flourish of trumpets which ushered in *Piumbago Larpentæ*, and where is it now to be found? *Viola cornuta* is better, but I imagine that those who planted their edging of this in March last have not received many compliments on its appearance, and yet, if two or three years in a place, it is very showy and a great acquisition.

I yet hope to see more made of the Forget-me-nots than has hitherto been done, but I can hardly believe in the number

of botanical species the names given would imply. I think there is room for improvers of florists' flowers to turn their attention to this genus, and if they can give us a hardy, compact-growing plant that flowers early, with blooms of a pretty blue with a buff eye, I would not care how small the individual flowers were, provided there were plenty of them to form a compact corymb. The later-flowering species or varieties, as *Myosotis azurea*, *coelestina*, and others, are pretty enough when they succeed well, but I have never been able to do anything with them. The season is generally too dry in this part of England at the time of their flowering for them to flourish, and, as there is no lack of blue flowers at the time, they are not so much wanted as earlier-flowering sorts.

The poetic associations of the plant will always entitle it to a place in gardens, but that place will be higher when improvement is carried a little further than it has yet been. The Lily of the Valley is a name equally venerated, yet the improved garden variety is quite as great a favourite as the wild one; and the interest taken in the Forget-me-not will not be lost when it is made to conform more to the requirements of a flower-garden plant, and if it can be induced to bloom somewhat earlier its value will be much increased. In colour it is far behind *Nemophila insignis* and some other plants. I remember one season having a quantity of Forget-me-not occupying two circular beds 10 or 12 feet in diameter, and in a line with them in a certain direction were beds of *Nemophila*, and further on some two-year-old edgings of the best variety of *Viola corouta*. In taking a view of all three from a distance of 50 or 100 yards, most persons pronounced in favour of the *Nemophila*, but as the latter is not to be depended on in severe winters, I would prefer a good hardy Forget-me-not if it could be obtained. From what I have seen here and elsewhere, *Myosotis dissitiflora* falls short of meeting the requirements needed in a spring-flowering plant. If others have been more successful with it, I shall be pleased to hear the particulars; only, if a plant requires special treatment of an inconvenient or labour-giving kind, it comes to me with a certain drawback; therefore, unless the propagation and culture of a *Myosotis* can be made as speedy and as easy as that of a Primrose, the plant loses much of its value, and something else must be substituted for it. Let us see if a few years cannot make as great an improvement on the *Myosotis* as was done in the case of the *Pelargonium*; certainly there is ample room.—J. RONSON.

FORMING A FLOWER GARDEN.—No. 3. ARRANGEMENT OF THE PLANTS.

The arrangement of the plants in the flower garden is a work full of interest, and a person to be successful should possess a thorough knowledge of the laws of colours, as well as skill, experience, and, above all, a natural taste and liking for the work. In a paper written by me on another subject, yet bearing somewhat on this, in stating the principles which should guide us in the arrangement of the colours in a flower garden, I considered "breadth of colouring without heaviness, brightness, cheerfulness, distinctness without gaudiness, variety without confusion, and the harmonious blending of the whole design," to be the most important points to be remembered. One colour should predominate just sufficiently to impart its peculiar tone to the whole design. Great caution must be exercised in deciding upon the number and position of the beds to be filled with this colour or its shades, for if there be an overwhelming preponderance of it, heaviness or glare will be the inevitable result. I have seen gardens in which some of the beds were really well planted, and the arrangement good and pleasing, but the effect was quite spoiled by some large masses of scarlet and yellow, so glaring as at once to attract the eye, and "kill" every other colour in their immediate neighbourhood.

Taking the centre of the garden as our starting point, the colouring here should be more massive in its character than at any other part. A deep scarlet flower, as *Stella Pelargonium*, or a rich crimson leaf, as *Coleus Verschaffelti*, is best adapted for such a position. A quantity of either of these sterling bedding plants grouped together in correct proportion to the size of the entire garden produces a rich, bold, and striking effect without any approach to vulgarity; and while they impart the requisite importance to the centre of the design, they form an excellent groundwork for other colours. An edging of pale yellow or grey might be formed around such a central group, but much subdivision of this or of any of the beds is to be avoided.

Neutral colours, such as soft grey or lavender, skilfully introduced, serve to divide and act as foils to the brighter colours. By way of example, I may mention a bed planted with Purple King Verbena in the centre, with an edging of *Manglesii Pelargonium*, the pink blossom of *Manglesii* being kept picked off, and another containing a mixture of *Perilla* pegged closely, and either *Parfum de Madeleine* or *Mrs. Mole Verbena*. The latter was designed by a lady, and is one of the best neutral mixtures I have ever seen. The position of such beds is a matter requiring much care, for when present in the slightest excess these colours impart an insipid tone quite as hurtful to the general effect as a preponderance of any other colour. The position of foil beds in gardens of large size is usually about midway between the centre of the garden and its boundaries, for as the rich colours of the key bed are usually repeated in smaller quantities in some of the outer beds, it is quite obvious that these neutral tints will be most effective in an intermediate position. Masses of bright colours in the outside beds serve to maintain an even balance in the colouring, and by attracting the eye cause the whole design to appear more expansive than colours of a quieter tone would do.

Of the colours requiring particular care in their use, yellow may be said to be the most important; a few masses of a bright yellow, such as we have in *Calceolaria Aurea floribunda*, judiciously introduced, light up and brighten a design with the best possible effect. If the beds are small, such masses are, I think, best seen pure and simple, surrounded only by the turf; but if a border or edging be used, it should certainly be of some complementary colour, such as a dark *Heliotrope*, or deep blue *Lobelia*, or a crimson *Iresine*. It may be useful to repeat the axiom here, that two colours placed in juxtaposition mutually influence each other. But while we recognise the importance of a knowledge of the laws of colours to render a person competent for this work, it will, I think, be granted that in the flower garden some modification of these laws may be allowed. Many instances might be adduced in which they have been broken with impunity. Green and blue are discordant, yet how frequently do we see broad lines of *Lobelia speciosa* next turf. It must be owned that a row of *Cerastium*, however narrow, outside the *Lobelia* is undoubtedly best, but then we may not always use it, and while the *Lobelia* is intensely blue, the turf more frequently approaches a brown, and I would rather have blue next the turf than render the garden insipid by planting too much grey. Again in purples, if we form a mass of Purple King Verbena without any other colour intervening between it and the turf, its effect is not weakened, because we have masses of its complementaries of yellow, pink, or white near it.

Another important point is the introduction of shades of the same colour; this applies especially to the multitudinous varieties of bedding *Pelargoniums*. If two of one colour are planted side by side, the brighter is certain to spoil the effect of its neighbour, and so it is best to select colours sufficiently distinct from each other to be really effective. This caution may also well be applied to novelties; it is quite useless to depend on the description given in the catalogues, and if the purchaser has not seen them planted out, it is always the safer plan to give them one season in the trial border before venturing to introduce them into the flower garden, where the planting should not be of a speculative character, but with varieties the merits of which have been fully tested.

ACCESSORIES AND SURROUNDING FEATURES.

The manner in which the appearance of masses of bright colour is affected by surrounding objects, does not appear to be so fully recognised as it ought to be.

The approach to the flowers should wind amongst the shrubs, under the shade of trees, or past green lawns, so that the eye, soothed and rested, may be prepared to enjoy the full beauty of the flowers. The approach to the terrace garden at Surrenden-Dering, designed by Mr. Nesfield, is very masterly. A broad, winding, gravel walk, having a belt of shrubs on one side, and a lawn on which are some fine old Cedars and other trees of a large size on the other, leads to a flight of stone steps, from the top of which there is seen on the one hand a broad expanse of turf, and on the other a glimpse of the flowers is obtained. Ascending another flight of steps a broad terrace-walk is gained, and from this elevated position, in a direct line with the centre of the design, the whole of the flower garden is visible, and the beholder is not only in the best possible position to enjoy its full beauty, but from this fine stand-point, if the colouring is good and the beds well filled,

the flower garden is displayed in the most favourable manner, and none of its finest features is lost. In contrast to this, I may instance another case where a fine walk passing through grounds of great extent, past handsome shrubs, and under noble trees, leads to a small flower garden of such puny dimensions as to be out of all proportion to its surroundings; but what tends more than anything else to completely spoil the entire effect is, that one corner of the design becomes visible first, and, consequently, a sort of diagonal view across the beds is all that this fine walk commands, and the impression conveyed to the mind is one of disappointment.

Another important feature is the position of the shrubs near it; many gardens are enclosed by a belt of shrubs, and these, by the exercise of a little care in planting, and in their after-management, contribute very much to the general effect. In such a belt the two front rows should be planted in quinconx—that is, every shrub in one line should be opposite the space between two plants in the other; they should also be far enough apart and well back from the beds to admit of their gradual formation into fine handsome specimens. These shrubs should not possess variegated foliage, but should be of a deep green. Of all hardy shrubs I know none to equal the Portugal Laurel for such a position; the handsome outline and deep hue of its foliage, and the ease with which the finest proportions may be imparted to it by the use of the pruning-knife alone—all tend to recommend it as the best shrub to use for this purpose. The common Laurel may have its admirers, but I think if a fair comparison of the two kinds be made, the deeper colour of the foliage, and the more elegant growth of the Portugal Laurel will cause it to find favour with the majority.

With regard to the introduction of Roses into the flower garden, while objecting to their use in such quantities as would influence or affect the colouring of the design, it is by no means intended to assert that some may not be used, and that with the happiest effect in certain instances. I can remember one such, where a small flower garden was laid out on a somewhat confined lawn, shut in by walls on three sides, and with the residence on the fourth. Now, the wall opposite the house was a low unsightly object with a public road close outside; and to conceal the wall and obtain a higher screen a row of shrubs was planted close to its inner side. This had the desired effect; but as there was only space for one line of shrubs, its aspect was that of a formal hedge. To break up this stiff outline, a double line of dwarf conical Rose trees planted thinly produced a pleasing effect; the handsome form of the plants tapering upwards from the turf, with their clusters of flowers, instead of detracting aught from the design, contributed materially to its finish and beauty.

Vases are almost always out of place in a flower garden; in fact, it may be stated broadly that nothing should be introduced into the garden itself, in its surroundings, or in the approach to it, but what is so quiet in tone and appearance as to make it entirely subordinate to the garden itself. One other word as to the garden seats. These should be of a simple but elegant form, and painted of a quiet neutral tint. Nothing can possibly be in worse taste than the lively green colour but too often visible on such seats.—EDWARD LUCKHURST, *Egerton House Gardens, Kent.*

CALADIUM ESCULENTUM AS A VEGETABLE.

TRAVELLING north through Philadelphia last summer, I noticed in the gardens, grown as an ornamental plant, our common Tanyah (*Caladium esculentum*). I had no idea it would thrive so well so far north. The leaves were not nearly so large as we have them here sometimes, for I have seen them in favourable localities 3 feet long, and at least 2 feet wide. Here we use it as a vegetable, and think it excellent washed and roasted, as Potatoes are sometimes, with the skins on.

When living in the north many years ago, we used to dig up in woods roots called Indian Turnips, and bake them in ashes which we made by kindling a fire in the woods. The root of this plant tastes very much like those Indian Turnips, which will give a good idea of them to those who have no knowledge of them.

A rich, wet soil, seems to suit them best. In this they furnish one big root and make many offsets in the manner of the common Tuberose, which side shoots make the sprouts for the next year's crop. Besides this, the roots can be more rapidly increased by dividing them into four, and perhaps more, as you would do a Rhubarb root.

I am told by a friend, that plants can be raised from the leaves, the leafstalks rooting in warm, wet soil, but of this I have no knowledge of my own. I think if you were to try that as a vegetable crop in your gardens, it might add one more to the many pleasant table dishes I so much enjoyed in my last summer's trip.—(*American Gardener's Monthly*)

ROKEFORD FITZPAINE.

I FEEL confident that the name of my kind and valued friend Mr. Radclyffe is so well known, and his opinion on those points of horticulture which he makes his special study so much valued, that a slight record of my annual visit will be acceptable to the readers of the Journal. Many will like to know how he has fared in this strange season, and whether the opinions he has advanced and the diets he has laid down have been in any way altered by the experience of the present year.

It has probably been thought by many who have read his enthusiastic remarks on the Rose, that he is revelling in some rich, nutritious, loamy soil, such as makes Rose-growing in Hertfordshire a comparatively easy matter; but I have endeavoured always to correct this notion. His soil is anything but a congenial one, and were it not for his use of the Manetti, and his excessive attention to the wants of his Roses at all seasons, he could not possibly succeed. I do not believe the Briar would do at all there, and where that is the case I need not say it cannot be said to be a good Rose soil. Then, again, he lacks the shelter in some parts of the garden that the Rose ought to have, provided that shelter be not caused by overhanging trees; as I have before explained, a great part of the garden lies open to the S.W. wind, the prevailing wind here, and which sweeps into it with the force of a hurricane, so that his canvas covering for his Peach trees has been often torn to shreds, and once, as we know, his brick wall was blown down.

I did not come here at this date (July 15th), to see Roses, for I knew from my own garden that was out of the question; indeed, the first bloom of Roses must be generally over by now, and we are on the look-out for those fine long shoots and that fresh growth of young wood which will give us good blooms in August and September. The French term *remontant* is much more expressive of their character than Hybrid Perpetual; they are not perpetual, but they do what no summer Rose does—throw out fresh shoots and give a second blooming season. But I came to see the Rose trees, and certainly no one could look at the *debris* of Roses on the bushes, the immense and overflowing clusters of dead blooms, and fail to lament not having been to see them in their beauty—no symptoms of the effects of drought, but everything in the most vigorous state. As to the yellows, it is impossible to conceive anything more vigorous. *Triomphe de Reims* is a marvel of beauty. There were six plants of this flower in front of the greenhouse and three of *Isabella Gray*, which formed a complete hedge—shoots, fresh shoots 4 and 5 feet long, with great clusters of blooms at the head of them, while hundreds had died away. *Isabella Gray* is too hard-hearted to display her charms, and so with a true Henry VIII. short and easy method Mr. Radclyffe is going to have her head off and bud *Maréchal Niel*, which is doubtless one of her own children, on her decapitated trunk. He is no admirer of novelties, "varieties without variation," as he styles them, so that they are not to be seen here in great quantities, but when he does get a novelty that he likes he goes in for it with a vengeance. He has lately highly extolled *Felix Genero*, and although my friend Mr. Peach does not agree with him, I (if Mr. Peach will allow me to be anything of a judge), think that the balance lies with Mr. Radclyffe. It is a good Rose in my opinion. Its shape is admirable, notwithstanding the row of outer petals being often small; its colour is not red, but a lilac rose; and it is a free and good bloomer. As to the test which Mr. Peach would submit it to, I fancy very few Roses would stand that—certainly Charles Lefebvre and Baroness de Rothschild would not, yet would Mr. Peach discard these? Now, so convinced is Mr. Radclyffe of *Felix Genero* being a good Rose, that he is going in for fifty of it. And this is the way which he adopts with really good Roses. Charles Lefebvre and Jules Margottin are to be seen by hundreds, and Comtesse de Chabillant, John Hopper, and others by dozens. He is equally determined in his proceedings when a Rose disappoints him. Mlle. Marie Girodte was highly recommended to him; he bought a dozen, but she is a "*trout rien*," and so off she goes this season. He, however, retains some kinds that others have discarded, such as *Duc de Cazes* and *Sonvenir*

de Dr. Jamain, and I think he is right; but as I mean to have a say on "some discarded Roses" by-and-by, I will add no more on this point. All over his garden the queen asserts her authority; it is "Roses, Roses, Roses everywhere"—on the front of his house, on the sides thereof, on the pretty bank at its back, in the rosarium proper, along the walks of his kitchen garden in double tiers: so that I do not wonder to hear that so many of all ranks and classes, admitted by his genial kindness to see his garden from far and near, have expressed their delight at the prospect.

Strawberries are another feature of Mr. Radclyffe's gardening, and probably nothing could more thoroughly testify his skill than their appearance at this season. Loud have been the complaints of deficiency of supply and smallness of the fruit, but such complaints find no echo here. I have never seen (I say it advisedly), such plants and such crops; for although I am here at the end of the season, the size and excellence of the Strawberries are something wonderful. As Mr. Radclyffe has, however, himself written on this subject, I can do no more than corroborate his views from personal survey. Mr. Radclyffe he regards as the finest-fleshed and finest-flavoured Strawberry. Dr. Hogg comes next in his estimation, and for general growth he advises it in preference to Mr. Radclyffe. Rivers's Eliza comes next, then John Powell; and for size and preserving, Cockscob and Wonderful.

This season is in general a good one for wall fruit, but I very much question if anywhere a more regular crop is to be seen than on the small trees which now cover Mr. Radclyffe's wall. He has had them now planted three or four years, and he might by this time, had he so liked, have covered the entire space with a few trees; but he prefers variety, and so has about 108, which he keeps within bounds by a judicious system of pinching. He does not allow them in a season like this to crop heavily, preferring fine fruits to a quantity of indifferent ones. There is no blistering on the leaves, and but little symptom of that pest red spider. In fact, going all over his garden, you could hardly imagine that we were in the midst of one of the most trying seasons on record.

Mr. Radclyffe, like myself, is pretty well tired out of Potato trials, and, although he has several new varieties growing in his garden, is determined for the future to cling to those he has already proved to be good. "Early ripener and late keepers" is his motto, and such sorts as the Old Ashleaf, Rivers's Royal Ashleaf, Cobbler's Lapstone, Taylor's Hybrid, and Yorkshire Hero seem to be all that he requires. Of the American sorts he has no opinion, and a Potato tournament he cannot see the value of. I confess I agree with him in this. Of what use is the best-looking Potato in the world if it is not a good one for eating? and some of the very prettiest Potatoes and largest croppers are in this predicament—for example, Premier and Prince of Wales; and I am afraid, if the judges were to be called upon to taste, so many are the varieties, that they would be like the celebrated wine committee, which at last ordered port instead of sherry, and sherry instead of port. A good Potato will, like the Lapstone, win its way, and all the Potato tournaments in the world will not help it on if it be indifferent.

What, then, is the secret? "Water." If with the Manchester school "Cotton is king;" if with the politician "Register! Register!" is the cry; so with my friend, Water is king. He has had two men constantly watering; and everything—Roses, Strawberries, Peaches, and Nectarines—has been well saturated; and this, with his rational common-sense method of doing things, secures him that success which often great theorists and would-be philosophers never attain to. I should add that "Sleeve" is as dry as ever, as thoroughly as ever believes in his master, is as laborious and painstaking as a man can well be, and does his best to maintain the credit of the famous garden he has to manage.—D., Deal.

SOFT SOAP AS AN INSECT DESTROYER.

ABOUT 1855 I was growing a few Dahlias, and soon after they were planted out they were nearly destroyed by the fly. In a bucket nearly full of water I mixed some soft soap, and taking some of the water in my hand I drew it up each shoot, commencing at the bottom, wetting the under as well as the upper sides of the leaves. There was not a fly to be seen next day. Seeing the effect on the Dahlia, I tried the experiment on Roses with the same result, but the improved appearance of the foliage surpassed that of the Dahlia. In applying the water to the Rose I take the end of the shoot in the left hand, and

with the right throw the water on, or hold the shoot over the bucket and wet the foliage well without wasting much water.

About nine years ago I put up a greenhouse, and grow a few Pelargoniums, Fuchsias, herbaceous Calceolarias, Cinerarias, and some other plants, but those I have named I found most subject to insect attacks. My house was glazed with rather small squares of glass, and was, therefore, not very easy to fumigate effectually. I nearly filled a large pail with water, mixed some soft soap with the water, and when any of the plants were attacked by aphid I took the pot in my right hand, placed my left hand on the soil to keep it from falling out of the pot, turned the plant upside down, and ducked it in the water. At the end of two years, when the solution was accidentally upset, it was as effectual as on the day it was prepared.

There appears to be some doubt about the proper weight of soft soap to use to a gallon of water. I always mix the soap in warm water first, taking care to leave none undissolved. A little soap will do no harm to any of the plants I have named, will kill the fly, and, especially in the case of Roses, will improve the beauty of the foliage. Of course greenhouse plants are only dipped when out of bloom, but doing so beforehand is a preventive of insects.

I have never had occasion to use soft soap to my Dahlias since 1865, but the Roses have required a dressing or two every year. As it seems to improve the foliage, I have applied the soft soap even when the fly has not made its appearance. I have scarcely known what mildew meant, and this year, although so hot and dry, I have not seen an aphid on the Rose. As I have been very busy, the plants were so clean, and the blooms the best I have ever had, the customary bath was not given, and now I have not a Rose on the Manetti or its own roots which is not white with mildew. Those on the Briar at present are all right.—J. C. H., Moorgate Grove, Rotherham.

THE ROYAL HORTICULTURAL SOCIETY'S OXFORD SHOW.

(Continued from page 47.)

VEGETABLES.

OF these, considering that there were only five classes, and these necessarily very limited, in which vegetables could be exhibited, the exhibition may be said to have been good, most of the articles being of very fair quality. Peas and Potatoes were well shown. These, however, were the only special subjects asked for. We should like to see vegetables generally better recognised at our provincial shows, and greater encouragement given to their cultivation. It may be that they have not such an ornamental appearance as fruit on the exhibition tables, and are not quite so attractive to the general sight-seer; still, being by far the most important products of a provincial garden, and their cultivation the most important of a gardener's duties—seeing, also, that the cultivation of vegetables is not what it should be, and that the rising race of gardeners are somewhat inclined to look down upon this department as derogatory, we think that the Royal Horticultural Society, which professes to hold its meetings for the encouragement of cultivation, would do well to make good vegetables a greater feature in their provincial exhibitions.

The prize given by W. Muntton, Esq., for the best nine dishes or baskets of vegetables, was awarded to Mr. George Craddock, gardener to Lord Willoughby de Broke, Compton Verney. In this there were excellent Cauliflowers, Parsnips, Peas, Globe Artichokes, Beet, Italian Red Onions, Prince of Wales Potatoes, good Tomatoes, and Cucumbers. Mr. Miles, gardener to Lord Carrington, was placed second, and Mr. Perkins, gardener to the Earl of Hartismere, Eye, Suffolk, third; the second prize being given by the *Oxford Journal*, and the third by W. Muntton, Esq. Mr. Broadbridge and Mr. Henwood, gardener to M. H. Turnbull, Esq., also competed with good collections. The Cauliflowers were throughout much finer than we could have expected to find them.

For the best three baskets of Round and ditto Kidney Potatoes, the prizes given by Messrs. Hall & Co., the competition in each class was keen, thirteen collections being set up. The first prize in both instances was awarded to Mr. Craddock, gardener to Lord Willoughby de Broke, the specimens being clean and well grown. The second prize for Round Potatoes went to Mr. Henry Miuchin, Hook Norton; the third to Messrs. Bell & Thorpe; and the fourth to Mr. Earley, Digswell. In the class for Kidneys Mr. Miles was placed second, Mr. Earley third, and Mr. D. Gammon fourth. For six dishes of Peas, "preference being given to collections containing Fortyfold and Miltum-in-parvo," the prizes being given by Messrs. Nutting & Sons, Mr. Simmons, Union, Thame, was placed first with very fine examples of McLean's Wonderful, Miltum-in-parvo, Premier, Fortyfold, Veitch's Perfection, and Berkshire Hero. Mr. J. Walker was placed second. In the class for three half pecks of Peas, one variety, the prize being given by Mr. David Day, some confusion seemed to exist as to whether it was intended for three half pecks of one variety, or for three half

pecks—half a peck of one variety. The prize was given to the three half pecks, distinct varieties, exhibited by Mr. Maunders, gardener to the Earl of Abingdon, Wytham Abbey—viz., British Queen, General Wyncham, and Ne plus Ultra, all of which were very excellent examples, the pods fine, long, full, and fresh. Mr. J. Perkins was placed second, and Mr. F. Sims, Marston, Oxford, third. There were no less than seventeen competitors in this class, and all the collections were creditable. Layton's Supreme, Ne plus Ultra, Premier, Veitch's Perfection, Champion of England, &c., were amongst the most noticeable of the other varieties exhibited.

Though not strictly coming under the head of vegetables, we may here add that Messrs. Sutton & Sons, of Reading, had in the Agricultural Show Ground a large and very complete collection of Grasses, seeds, roots, &c., and Messrs. Carter & Co. had a similar collection.

HORTICULTURAL APPLIANCES, IMPLEMENTS, STRUCTURES, &c.

This department of the Exhibition was very meagre—meagre as to extent and meagre as to quality. As to the implements and a great portion of the appliances or useful articles applicable to horticulture, a better selection could be obtained by turning out the interior of any ordinary ironmonger's shop. As to structures also, with a few exceptions, we can say but little. In this special department, indeed, specially pertaining to the garden, the exhibition in the yard of the Agricultural Society was infinitely superior, more varied, and more extensive, the exhibitors thus finding it more to their interest to exhibit at the great gathering than at the little show. Mr. Beard, of Bury St. Edmunds, exhibited some of his patent glass walls, which are to be used instead of brick. The glass used is common rough plate in large squares, set on edge, and fixed in grooves in upright iron pillars. They have a very light, elegant, and pretty appearance, take up but little space, and are thus recommendable for small gardens. They will provide shelter for the plants trained against them, but cannot in any way compete with brick walls in a horticultural sense.

Mr. Ormson, of Chelsea, exhibited several forms of wrought-iron boilers, which seem to be of a very powerful character, also drawings and designs for hothouses, &c. Mr. Ormson further exhibited models of his new patent ventilating hot-water apparatus, which appears meritorious, the cold air being admitted into the centre of a cylinder heated by four pipes, which are cast in one piece with the cylinder; combined with this, the rafters are made hollow and faced with perforated zinc, whereby all stagnant and vitiated air is carried off by ventilators in the back wall, and which can be regulated at pleasure. As a means of ventilating in winter this method of Mr. Ormson's is, we think, very excellent. The glass used by Mr. Ormson is of immense thickness, being what is known as 32-oz., and is fixed in grooves, thus doing away with front putty, which is always expensive to keep in repair.

Messrs. Weeks & Co. exhibited models of greenhouses, &c., and of their well-known upright tubular boilers, one of which is further altered by being made in two halves, either of which may be used whilst the other is being repaired. Mr. Rendle exhibited numerous examples of his patent plant-protectors, ground vinerias, &c. Mr. Leoker had also his patent propagating boxes and other ingenious contrivances for the cultivation and propagation of little things. These may be all very useful in their way, especially to amateurs. Mr. James Cranston, Birmingham, had examples of his patent greenhouses, which have the merit of being very ornamental.

From Messrs. T. H. P. Dennis & Co. we have a novelty in Gilbey's patent glass orchard, represented in the accompanying engravings. It is at least ingenious and simple, and also neat in appearance. We cannot say, however, that we should expect great results from it. The same firm also exhibited two strong lean-to houses, the sashes and sashbars being made of galvanised iron; these had a light and elegant appearance. They had also examples of their square tubular boiler. Mr. P. J. Perry, of Banbury, had a model of what is very modestly styled "The Improved Peach House," a lean-to, the glass being in large squares, and fixed with strips of flat lead instead of putty. Messrs. Messenger, of Loughborough, exhibited a structure invented and patented by Mr. Ayres, of Nottingham. This is called the "Imperishable Hothouse," and so far it is almost worthy of the title. The glass itself will not perish, and the glass is held in its place by small clips of brass or other material, which will likewise not perish. The house consists of a mere framework of rafters and mullions, placed from 6 to 8 feet apart, and connected together by cross pieces of iron or wood at such distances apart as may be required to take the glass, which is laid on in much the same way as tiles on the roof of a house, and held fast by the clips as before stated. We have some objection to the lapping-over of the glass at the sides, otherwise we consider this a decided move forward in horticultural structures. The outside being all glass, no painting whatever is required, and what a wonderful

saving this must be!

Messrs. Green & Son had some of their most excellent lawn mowers on view; and the new Archimedean was shown by Messrs. Gill & Co., of Oxford, besides a great variety of minor articles. Messrs. Dick Radclyffe & Co. had some mowing machines and other articles on view; and Messrs. Haynes & Sons had a large stand of their patent hydromettes, which are too "squirty" in their action to meet with much approval. There were, besides, Appley's and Drechsler's fumigators, neat wire flower baskets, and various other articles in wire-work, from Mr. Holliday, of Notting Hill, as well as many other things of a miscellaneous character.

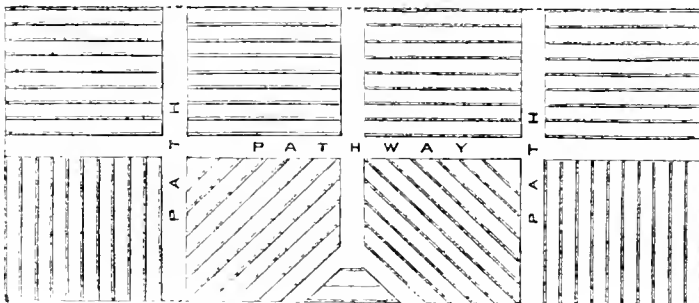
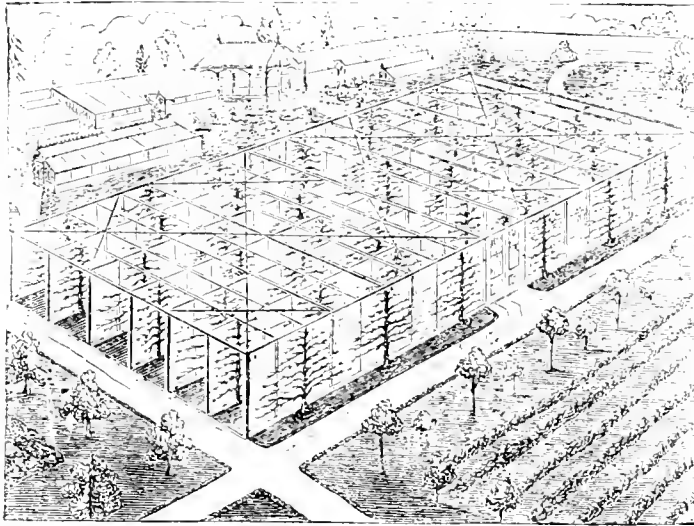

PLAN OF A QUARTER ACRE

THE GENERAL MEETING AND HORTICULTURAL CONGRESS.

At the General Meeting, held on the 20th, G. F. Wilson, Esq., F.R.S., was in the chair. After the usual preliminary business several new Fellows were elected. The only object of special interest not before reported upon, was *Macadamia ternifolia*, of which Dr. Masters exhibited the nuts, which were too late to be submitted to the Fruit Committee. These nuts were

stated to be fully equal to Filberts in flavour, and were accompanied by the following remarks from Dr. Hooker:—

"A year ago I received from Australia ripe seeds of the *Macadamia ternifolia*, for the garden, and happening to taste one, I found it to be so excellent in texture and flavour that I at once wrote to my friend, Mr. Hill, of the Brisbane Botanic Garden, to send me a supply for trial as a dessert fruit. The box has now arrived, and Mr. Hill requests me to forward a sample to the Scientific Committee for an opinion, which I now do. I should add that, the box having been delayed considerably in transmission, some of the nuts have deteriorated in consequence.—J. D. HOOKER."

THE HORTICULTURAL CONGRESS commenced on the 20th inst., was presided over on that day by G. F. Wilson, Esq., and was well attended. Dr. Voelcker opened it with a lecture on "The Principles of Manuring." He was glad, he said, to have the opportunity of imparting in-

formation to the horticulturist, although hardly knowing in what manner to treat the subject, for the simple reason that the horticulturist was far in advance of any theory that could be laid down to regulate his proceedings. The agriculturist, on the other hand, was far behind the horticulturist in practice, though well aware of some of the great principles which should guide him in the application of manures. It was within the agriculturist's power to increase the crop in an average season by the judicious application of farmyard manure, and in the event of the supply of dung running short, he could apply artificial manures in certain proportions which experience had shown would produce a particular effect on the crop. The farmer, by experiment, had learnt precisely what to do in order to attain his object—when to give a supply of manure, and when to withhold it, and he also knew what particular kinds of manure were useful at certain stages of growth, and when to withhold them. A gardener, as a rule [no, no], could command any amount of stable manure, whilst the agriculturist was not in such a favourable position, being often compelled by the force of circumstances to eke out his deficiency by using certain artificial manures, generally expensive even when applied in the best manner. Dr. Voelcker then said he would arrange his remarks under the following heads:—First, The nature of the organic and mineral food of plants; secondly, the properties of ordinary stable manure and artificial manures; thirdly, the time of application; and fourthly, the fertilising combination and the special uses and effects of manures.

In the first place, in reference to nitrogen, he considered a supply of it necessary to growing plants. This was one of the questions upon which there is a good deal of dispute among scientific men. Nitrogen was not absorbed by plants directly from the atmosphere, which, however, contains small quantities of ammonia, which are absorbed by a porous soil or by rain, rain carrying with it at the same time small quantities of nitric acid. He would, therefore, to insure the healthy and luxuriant growth of garden plants, make use of nitrogenous manures. Then the question would arise, In what form was this nitrogenous food best supplied to plants? He would supply it in the shape of ordinary dung, in which it is to be found as a nitrogenous substance in a progressive state of decomposition, partly as ammonia, and partly in the form of nitric acid. Mineral manure, which could only be derived from the soil, was not only essential to the existence of plants, but absolutely necessary for the luxuriant development of every kind of produce. In this sense lime was as important as potash, sulphuric acid as phosphoric, soluble silica as any other mineral composition which entered into plants. There were certain matters spread throughout the soil that occurred in very small quantities, while others were of more abundant distribution. The alkalis, potash more especially, on some descriptions of land were more sparsely distributed than the corresponding soda or magnesia. Then, as to the combinations on which plants feed, nitrogen is always present in great variety, so that if in one form it fails to exert its beneficial influence, it will be sure to do it in another, and this is of great practical advantage. Sulphate of ammonia and nitrate of soda are especially useful to the growing plant; but if applied at the wrong time they are very dangerous. Experiments had been carried on in Germany during the last four or five years with plants which ordinarily grow on arable land, and which had been successfully cultivated in various solutions, but if the solution was too strong the development of the plants was greatly interfered with. Great care should be exercised in using manures which are quick in their action, and he questioned whether they should be used at all, but he would recommend good top-dressings. If good results were to be secured from the application of phosphoric acid, potash, ammonia, and nitrates for horticultural purposes, these ought to be mixed with a large mass of soil, and used in the form of a compost. He was of opinion that manure could not be applied too early in autumn, and if thoroughly mixed with the soil it entered into a great variety of combinations favourable to the growth of plants. All soils possessed the remarkable property of fixing some of the more fertilising ingredients of manure, provided sufficient rain fell to enable the ground to do so. With regard to the effects of certain manures upon plants, he found that these affected not only plants, but also particular parts of plants. No doubt the application of phosphate manures had done much to bring root crops to that perfection in which they were seen at shows. If the regular supply of phosphates were withheld, he believed root crops would return to their original fibrous condition. By the application of strong forcing manures, containing mineral matters as well as nitrogen, to which element their forcing action was mainly due, leaf-growth would be obtained at the expense of well-ripened wood and fruit. Other manures promoted early maturity, which was of especial importance to fruit-growers, and to this result a combination of phosphatic manures with potash contributed. Potash and phosphate of lime, as in mixtures of the latter and wood ashes, gave, perhaps, a better crop of fruit than any kind of manure. The best form in which phosphate of lime could be applied for the purpose of growing fruit was that of bones partially deprived of their nitrogenous matters, of which they contain too much to be useful for fruit-growing in great perfection, more especially Grapes. Better fruit was often produced by using only half the quantity of manure. An artificial manure containing a good proportion of potash was often of great use, provided the potash was not in too large quantity, when it retarded rather than forwarded the development of plants. If land were of a sandy nature a limited mixture of salts of ammonia would be found very useful.

In some experiments which he had recently tried, he had increased the produce of a crop of Potatoes by the following dressing—viz., 4 cwt. of superphosphate, 2 cwt. of potash, and 2 cwt. of ammonia, costing 33s. per acre. The produce amounted to between 12 and 13 tons, while an unmanured portion only produced 6 tons per acre. This showed what could be done by a proper selection of manure. He had also tried another experiment, using only superphosphate and potash, and omitted the ammonia, and the result was that the crop fell short by 3 or 4 tons, thus showing the great service rendered by the ammonia. He believed that there was a great field open for investigation with reference to the supply of manure to fruits. Within the last few years several fruit-growers had dressed their Gooseberry bushes with artificial manures, and with great success. In pot-culture they should not apply any strong quick-acting manures, but they should prepare a compost, and use it with discrimination.

The Chairman said he believed there were some gentlemen present who took rather a different view from that of Dr. Voelcker, especially upon the source of the supply of nitrogen to plants, and he would, therefore, invite discussion upon the subject.

The Rev. C. P. Peach remarked, that of the various constituents contained in plants, nitrogen rarely existed to the extent of more than 2½ per cent. In grain, analysis gave us 2½ per cent., and in the case of Potatoes about 0.7 per cent., and this after the materials had been partly deprived of their hydrogen and oxygen. He thought it was going too far to say that nitrogen was of more value in a plant than any other substance; the carbon, for instance, amounted to 50 per cent. of the whole. Nitrate of soda and ammonia formed the only two useful ingredients of the chemicals sold for manuring purposes. Ammonia had very great power in dissolving carbonaceous matters and rendering them available for the food of the plants, which, when growing, took their carbon principally from the soil, and he was inclined to think that in this lay the great value of ammoniacal substances. It was commonly stated that a plant could obtain the hydrogen which it required from water, but his opinion was, that it was obtained more easily from ammonia. Silica was one of the most insoluble substances, but plants took it up by the roots, its solution being facilitated by alkaline salts, and hence the value of nitrate of soda. He thought silica was more valuable than nitrogen to the plant. He considered that, though temporarily guano might be of great service, its effects were not permanent. Nitrogenous matters were important as facilitating the formation of diastase, which as a solvent of starch was of the highest importance in plant nutrition, and on this account, rather than for any direct value, nitrogen was important.

Dr. Gilbert remarked that Mr. Peach's statements concerning the percentage of nitrogen in various crops was irrelevant. It was a question which had been under discussion for the last thirty years, and most elaborate experiments had been made. Boussingault and Ville had come to the conclusion that free nitrogen is not absorbed by plants, and the latter was at the present time making quite a sensation in France by his advocacy of nitrogenous manures. Mr. Lawes and himself had worked for several years to determine this question, and their conclusions were, that if nitrogenous substances were withheld, and only free nitrogen had access to the plant, no increase in the quantity of nitrogen in the plant took place; but when a small quantity of ammonia was given, it showed its effects in less than twenty-four hours. Mr. Peach had stated that the small quantity of carbonic acid contained in the atmosphere was insufficient for the proper development of plants, but he considered there was an ample supply in water and the air. The presence of an increased percentage of silica did not strengthen straw, as he had found that in almost all cases the best standing crop was that in which the lowest proportion of silica was found. In approving of the manner in which Dr. Voelcker had brought the subject forward, Dr. Gilbert stated that horticulturists would have to carry out many experiments before they would be able to get at the principles which had been so long arrived at in agriculture. The horticulturist had a far larger field for experiment than the agriculturist, in the vast number of his products and the wonderful control he had to exercise over the growth of plants. At present they had arrived at some useful results—results, perhaps, not quite conclusive, for they must not look to obtain from a few years' experiments the conclusions which they would eventually succeed in arriving at.

Major R. Trevor Clarke fully concurred in Dr. Voelcker's views with regard to manures applied in a solid form being more beneficial than those in a liquid state. One of their most clever Rose-growers, who was present (the Rev. Reynolds Hole), was well aware of their superiority. Great development in root crops and fruit was mainly due to the use of manures rich in phosphates, and he thought there was a very good field open for physiologists to experiment in; for instance, in causing plants to revert to their original state, or to develop into new races.

Mr. D. T. Fish said that if the gardener desired a good crop of Roses he must have rich manure. The farmer was content with one crop where the gardener required three, and therefore it was necessary that the gardener should use a much greater quantity of stable manure. The time of applying it had also a very great effect upon the crop, and he had found that those farmers who left the manure upon the top of the ground in winter had the best crops. Soluble manures were certainly those which accomplished the greatest good. He believed that the atmosphere contained sufficient material for the food of plants without much aid from the soil, and he should account for

the presence of silica in Orchids and other tree plants by the presence of it in the atmosphere, as the roots of these plants never touched the soil. This, he thought, was borne out by Professor Tyndall's recent experiments. This was a very interesting question, and he hoped some of their scientific men would be able to throw some light upon it.

The Chairman then proposed a vote of thanks to Dr. Voelcker, which was unanimously agreed to.

Dr. Voelcker, in returning thanks, remarked that there is always an abundance of silica both in soils and water, and that silica applied in the form of dust would certainly do no good to the plants.

Mr. Ingram's paper on "The Distribution of Soils, and their Influence on Vegetation," was then read, but elicited no discussion.

The Congress again met on the 21st inst., Major R. Trevor Clarke occupying the chair. The first paper read was by Professor Lawson, and entitled "A Short Account of some of the more Eminent Oxfordshire Botanists and Gardeners."

The Rev. S. Reynolds Hole then made the following remarks on Roses.

Mr. Hole commenced by mentioning that ten minutes being the time allowed to each speaker, he would have to compress twenty-five years' study of the Rose into that time, much in the same way as they compressed several ounces of meat into small lozenges, a box of which would last a man for a week's travelling. There were three main elements required to grow good Roses—site, soil, and sustenance. As to site, the Rose should be protected from boisterous winds, and at the same time have plenty of fresh, pure air. It did not much matter whether the site was a hill or table-land, provided there was plenty of timber to make natural screens, so that the wind came in as through a respirator. They must not come to him and say there was not sufficient space for this; it must be found where there is shelter and not shade, as overhanging boughs were fatal, as also were the main roots of trees. There was a Rose called the Royal Horticultural Society, which had been attempting to bloom for the last three or four years under the shade of a large tree, called the Agricultural Society, and although it had had the most consummate skill and the best attention paid it, still its efflorescence was not satisfactory. "Let it come away from the large timber," said Mr. Hole, "and then gather ye your golden Roses." Where Potatoes would grow well there was the Rose to be found in its glory. Then as to soil, plenty of lime in Rose soil added additional brightness to the glowing colours. With regard to sustenance, he would recommend good farmyard manure as the best food for Roses. Much good had been done by the use of artificial manures, but they would always remain second and supplemental to farmyard manure. Manure should be laid on liberally in November, and dug-in in March, and then one more dressing should be given when the buds began to swell, and the colour to show. Pruning should be done in October, and the weak wood cut out in March. The great enemies of the Rose were aphid and mildew, but if it had proper soil and sustenance these would never appear unless caused by spring frosts. For the caterpillars there was no remedy but to employ children, and have them picked off by the hand. The best stocks from which to select Roses were those which most frequently took the great prizes at our exhibitions, but if they only wanted a Rose garden and did not care about exhibiting, let them buy in a large proportion of Roses upon their own roots, because they were prettier, more abundant in flowers, and more enduring, and, therefore, more economical. The best stock for the Rose was the Manetti.

We understand that the total number of the visitors at the Show amounted to about 12,000.

SEA-SIDE PLANTING.

From the remarks which have appeared in your columns from time to time on this subject, it would seem that additional particulars would be acceptable.

One of the principal points to be considered is, as Mr. Robson and Mr. Owen have remarked, that of soil, which differs so considerably along the coast-line of England. Confining ourselves to the southern portion of the kingdom, it is obvious that the same standard could not apply alike to the district of the Dover cliffs, of the Cornish downs, and the slopes of Torbay. To treat them alike because they agree in the bare fact of being lines of sea-coast would be to fail. Take, again, the important differences of climate; these are illustrated by the state of growth to be seen in the narrow district of the western half of the county of Cornwall. There passes down through this section a backbone of granite hills, which in a rough way equally divides its width. From the base of this range northward to the sea, for instance, the Larch and Spruce Firs succeed hardly in a single case, and for a full length of fifty miles it would scarcely be too much to say that no one tree of either of these kinds is worthy to be called a specimen of ordinary symmetry; but immediately you leave the grim granite, southward they grow successfully, and within ten miles of where the failure of these and many other desirable trees is apparent, choice and beautiful arboreta are to be seen.

In confirmation of this, if any of your readers find themselves in the neighbourhood of Falmouth, for instance, and will visit, say, the grounds of B. W. Fox, Esq., Pen-jerriehe, they will be satisfied that almost abutting on the sea it is possible to rear one of the finest collections of Conifera and other choice growths probably to be found in England. Then let them steer due north until they find themselves equally near the sea of the north channel, and the contrast will be complete. This difference in so small an area of country is due not so much to difference of soil as of climate, for if the soils of the northern and southern sections were exchanged the difference would probably continue. The main reason of this variance is, of course, that the storms which so keep down the foliage come principally from the north and west, and whilst the northern is mercilessly beaten by these, aggravated by saline particles, the southern portion enjoys comparative immunity owing to the shelter of the range of hills.

Along the north coast nothing is found so successful for an outsider as the Black Italian Poplar stuck in almost as thickly as bean-stalks, and cuttings answer nearly as well as rooted trees. No ill-usage of the weather or neglect of the planter seems able to prevent its rapid growth.

The next line of planting should be an evergreen shelter; invaluable for this will be found a mixture of the *Pinus austriaca*, Evergreen Oaks, and many species of the large-leaved Hollies, particularly *Ilex nobilis*, which enjoys the southerly of Dreadnought in this neighbourhood. This class of Holly is not cultivated so much as it deserves. The common one is no great acquisition, but the larger-growing kinds grow faster, stand unblemished in the severest frosts, rarely suffer from storm, and, moreover, are beautiful in their foliage and outline.

Amongst the Conifera that may safely be planted within the lines named, I should class as being at the same time most ornamental and hardy, *Picea Nordmanniana* and *Abies Menziesii*. *Wellingtonias* are useless, *Cedrus Deodara* is a failure, and the *Arbor-Vita*, Cypress, and Juniper tribes scarcely ever succeed, but almost always suffer more in the winter (rather, I think, from the action of the salt than from the force of the wind), than they recover in the summer, and so gradually deteriorate. The *Pinus insignis* is, I suppose, tried oftener than any other tree of its class, and with various results. It is to be observed that a great difference exists in the appearance of different specimens, and in the seedlings of the same bed; whilst some have a texture approaching in course hardihood to the *austriaca*, others are obviously of more delicate constitutions, the leaves being finer and more numerous, the colour more delicate, and this variation is all the difference between its being a most handsome and valuable tree, which cannot be too often planted, and its being an eyesore. The Stone Pine is found valuable also. The Scotch and Pinaster Firs should be excluded as much as possible, as their shattered remains, scattered on the barren downs, or near the ruins of a defunct mine, remind one of nothing so much as rare old Bewick's woodcut of "Desolation"—a half-starved donkey, by a ruin on a barren waste, in a pelting storm, chewing the remains of a broom. The English Yew will succeed if somewhat sheltered, but if prominently exposed will fail miserably.

Of deciduous trees the Cornish Elm, Alder, and Sycamore do best; the Poplar should not only form the windward wing, but should also be sprinkled over the whole wherever there is standing room, to be, of course, cut out as the permanent growth fills up. The Sycamore certainly acquires a battered appearance by the autumn; but, nevertheless, does not so shrink from the wind as the Elm, which, although indigenous, never holds its head erect where there is any wind-drift, but looks like a weathercock permanently indicating a north-west gale.

As to flowering trees, if "WILTSHIRE BECTON'S" floral experience were confined to this district, "by the Cornish sea," where the Lilac and Laburnum dare not droop their lovely pendants, instead of giving us his charming little Lilac-tide article, he would have been compelled to write a pastoral on the Tamavisk, which holds the field in their stead; and besides its usefulness, who has not felt its beauty, and lingered by it after a gentle summer's rain or heavy dew—

"When the great sun begins his state,
Robed in flame and amber light?"

As to shrubs, in the first rank must stand *Escallonia macrantha*, *Euonymus*, and *Berberis Darwinii*; next in value come *Phillyreas*, *Garrya elliptica*, *Daphne Fionians*, Hollies, plain and variegated; *Elmagnus*, and *Spiræas*. The Laurel and *Laurustinus* are not equal to the foregoing, as the wind easily strips them; the *Arbutus* and Bay will be found to be more

successful. For covering walls *Cotoneaster microphylla* and *Simmonsii* may be used, and in many instances *Ceanothus azureus* and *Veitchii* do very well. Worth noticing also is the success of the Elder as a screen in kitchen gardens, fruit quarters, &c. Around the Mount's Bay in particular, the seat of the earliest vegetable and fruit produce of the country, these may be seen more frequently than elsewhere. The cuttings strike easily, and planted in single rows in a few years run up, and when kept close-cut the little ground they occupy, the rapidity and close inwoven-form of growth, would make this

screen, but for its drawback of being deciduous, and, I suppose I must add, want of beauty, the consummation of shelter. Privet, Hornbeam, Thorn, and other fences are tried frequently, but never with the success of an Elder hedge. In ground, however, where appearance is more important, the *Escallonia* makes the best evergreen hedge; in Scilly it is the favourite, and does most of the hard work there. In fact, this is among shrubs what the Poplar is amongst trees, indispensable to success in seaside planting.—CORNUBIA.

GLASS WALLS.

THE accompanying engraving is a representation of a structure I have recently erected. It differs somewhat from those I have called double walls of glass; it being the intention to force the fruit in this structure, it was necessary to add a roof, in all other respects, with this exception of its being wider at the top, it is similar to the glass walls which I first introduced.

In this structure the ventilation is not only in the roof, but on each side under the gutter which carries off the water from the glass, the earth being removed to the depth of 4 or 5 inches, thus enabling the air to pass up between the trellis and the glass, birds being excluded by galvanised wire netting.

In a former article I have described the mode in which the glass is fixed in grooves, in which are inserted triangular pieces of copper to clasp the glass, keep it tight in the grooves, and prevent one sheet of glass slipping down over the other. I have also described the mode of preparing the timber, so as to render unnecessary any painting afterwards, which, with puttying, are very important items of expense in horticulture. My present experience leads me to hope that insects will not harbour in timber that has been boiled in creosote. Some persons object to the colour of the wood thus prepared, which in the course of a few months becomes of a rich brown; if thought proper the fronts of the

rafters might be painted stone colour in the course of a year, which would give the whole a lighter appearance.

As I have before alluded to the advantages to be derived by this mode of growing fruit, I will merely mention a few of its most important features—viz., thorough control over autumnal rains; perfect ventilation by the passage of the air between

the trellis and the glass, both surfaces of the leaf being thus exposed to light, for without quality in foliage we must not expect quality in fruit; thorough ripening of the wood; command over the red spider; and, to crown all, we have every part of the fruit thoroughly ripened. I may also add that early fruit is ripened a fortnight earlier, and that late fruit becomes thoroughly ripe.

The fruit trees in the structure here engraved consist of various kinds of Peaches, Nectarines, Apricots, Plums, Cherries, Figs, Strawberries in the border, and Grapes, the last being trained along a wire under the ventilator, which ventilator is opened or shut

simultaneously throughout the whole length of the structure by the usual mode of a winch. I was induced to try various experiments to insure a crop of fruit independent of the weather, a very large supply being here required for consumption. I have now had sufficient time to test this last experiment, and I can recommend its adoption with the greatest confidence.—OBSERVER.

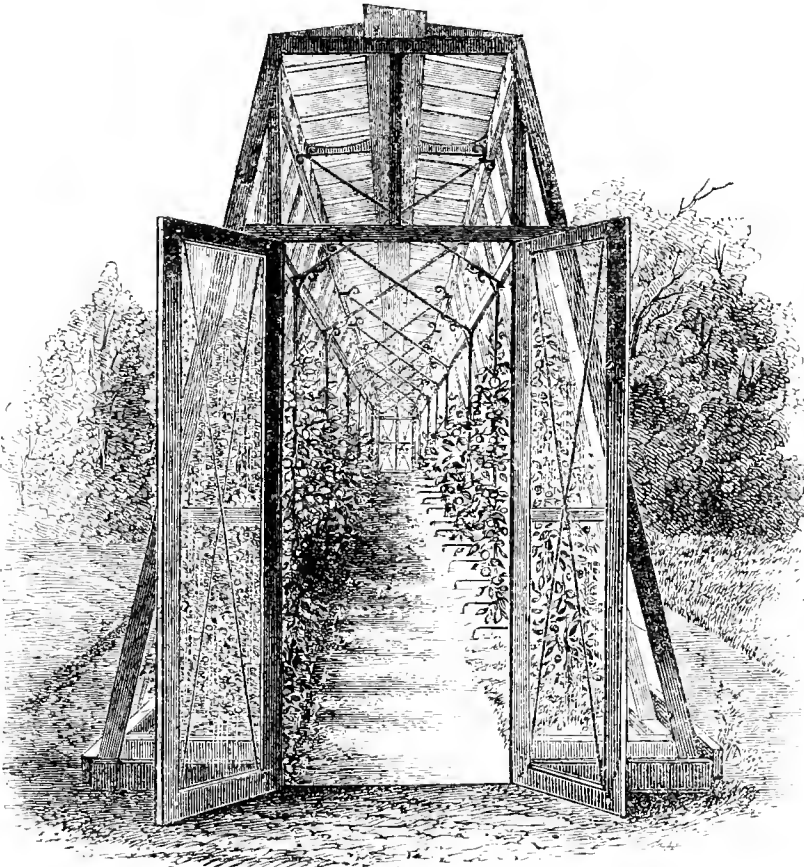

THE WORK DONE BY A LEAF.

Now, what does it do? It pumps water from the ground, through the thousands of tubes in the stem of the tree (the tubes which itself has made), and sends it into the atmosphere in the form of unseen mist, to be condensed and fall in showers—the very water, that, were it not for the leaf, would sink in the earth, and find its way perchance through subterranean channels to the sea. And thus it is that we see it works to give us the “early

and the latter rain.” It works to send the rills and streams, like lines of silver, down the mountain and across the plain. It works to pour down the larger brooks which turn the wheel that energises machinery, which gives employment to millions. And thus a thousand wants are supplied, commerce stimulated, wealth accumulated, and intelligence disseminated through the agency of this wealth. The leaf does it all.

It has been demonstrated that every square inch of leaf lifts 3-500ths of an ounce every twenty-four hours. Now, a large forest tree has about five acres of foliage, or 6,272,640 square inches. This being multiplied by 3-500ths (the amount pumped by every inch) gives us the result—2352 ozs., or 1176 quarts, or 294 gallons, or 8 barrels; a medium-sized forest tree, about 5 barrels. The trees on an acre give 800 barrels in twenty-four hours. An acre of Grass, or Clover, or grain, would yield about the same result.

The leaf is a worker, too, in another field of labour, where we seldom look, where it exhibits its unselfishness—where it works for the good of man in a most wonderful manner. It carries immense quantities of electricity from the earth to the clouds, and from the clouds to the earth. Rather dangerous business, transporting lightning. I think it would be considered contraband by the "U.S.," or "Merchant's Union," or any common carriers: but it is particularly fitted for this work. Did you ever see a leaf entire as to its edges? It is always pointed, and these points, whether they be large or small, are just fitted to handle this dangerous agent. These tiny fingers seize upon and carry it away with ease and wonderful dispatch. There must be no delay; it is "time freight." True, sometimes it gathers up more than the trunk can carry, and in the attempt to crowd and pack the baggage the trunk gets terribly shattered, and we say that lightning struck the tree. But it had been struck a thousand times before. This time it was overworked.

As we rub a stick of sealingwax or a glass tube with a warm silk handkerchief, so the air is always rubbing over the face of the earth with more or less rapidity. And what a huge electrical machine! But be not afraid, the leaf will see that it is taken care of. As we guard our roofs from the destructive action of lightning—dashing to the earth—crashing, rending, burning on its way—by erecting the lightning rod, whose bristling points quietly drain the clouds, or failing to do this, receive the charge and bear it harmless to the earth—so God has made a living conductor in every pointed leaf, in every blade of grass. It is said that a common blade of grass, pointed by nature's exquisite workmanship, is three times as effectual as the finest cambric needle; and a single twig of leaves is far more efficient than the metallic points of the best constructed rod. What, then, must be the agency of a single forest in disarming the forces of the storm of their terror?

Nature furnishes the lightning, and it furnishes the lightning rods. Take a hint, then, and plant trees.—(*The American Entomologist and Ecologist*)

EXTRACTS FROM THE REPORT ON THE BRISBANE BOTANIC GARDENS.

Among the plants used for tanning purposes are mentioned the Sumach (*Rhus Cotinus*), &c., all of which are flourishing, and eventually will, doubtless, become here of great practical utility and value. The Croton Oil (*Croton Tiglium*), the Candle Nut Oil (*Aleuritis triloba*), two species of Castor Oil plants (*Ricinus communis*, and *R. spectabilis*), have been properly tested, and will, beyond doubt, yield most remunerative profits to both the cultivator and the manufacturer.

Of the Tea (*Thea Bohema*) and the famous Paraguay Tea (*Ilex paraguensis*), the Coffee (*Coffea arabica*) most excellent samples have been made, and it can hardly be doubted that before many years Queensland will be independent of the world for a supply of these luxuries. The Allspice (*Pimenta vulgaris*), the Ginger (*Zingiber officinalis*), the Turmeric (*Curcuma longa*), the Cardamon (*Elettaria Cardamomum*), the Grain of Paradise (*Amomum Melegueta*), the Tapioca (*Manihot utilisima*), the Cassava (*Manihot Jatropha*), &c., are growing luxuriantly, and samples of all, and of superior quality, have been manufactured.

Among the tropical fruits may be enumerated the Mango, the Cherimoyer, the Soursoop, the Sweetop, the Jack Fruit, China Date Plum, the Avocado Pear, Bananas, &c. Pears were publicly expressed in Brisbane a short time since that the Banana was deteriorating, but under careful cultivation it is satisfactory to know that there is no reason for apprehension on that score.

The silkworm trees, *Morus cedrona*, *alba*, and *multicaulis*, the *Ailanthus glandulosa*, &c., remain in excellent condition, and are frequently inquired after by those who are interested in sericulture. I would respectfully propose that cuttings or plants of these trees be planted on the grounds of the Orphanage, they would answer the purpose of shade trees, and would

serve to amuse the children by furnishing food for their silkworms. Frequently applications are made by them at the gardens for leaves of the Mulberry for this purpose.

SELSEY ISLAND.—Your correspondent "G." is wrong in speaking of a living Lord Selsey, for the title became extinct in 1838, owing to the absence of male issue. There is no doubt that the last baron who bore the title fostered the culture of the soil, and may have inherited the taste, for he was descended from one of the most celebrated gardeners of a previous generation. His ancestor, Sir John Peachey, married a daughter of George London, Esq., of Long Ditton, who was Superintendent of the Royal Gardens in Ordinary to Queens Mary and Anne.—J.

WORK FOR THE WEEK.

KITCHEN GARDEN.

Use all diligence in filling up vacant pieces of ground with *Broccoli*, *Borecole*, *Brussels Sprouts*, *Colworts*, &c.; and where ground is scarce, crops likely to come off soon should be interlined, for the purpose of establishing as large a breadth of the above useful vegetables as can be done. Hoe frequently between young crops, and plant out a good supply of *Endive*, *Cauliflowers*, *Walcuren Broccoli*, and *Cabbage* for the autumn. Sow *Lettuce* and *Onions* to stand over, and *Radi-shes*. Liberal waterings twice or thrice a-week in dry weather will be required by *Peas*, *Cauliflowers*, *Spinach*, *Artichokes*, *Lettuces*, &c., rendering them not only better in quality, but making them last longer in perfection. Sow immediately Wheeler's Imperial and other approved kinds of *Cabbage* for the principal spring crop. Sow thuly on good, but not rich land, and in an open situation, which are points to be kept in view in sowing all seeds of this class. The earliest *Celery* may be forwarded by small additions of earth. Sow small quantities of *Basil*, *Chervil*, and *Marjoram* required for use in a green state. Let a good sowing of *Bath Cos Lettuce* be made directly. This will stand all the autumn, and on well-prepared ground will produce fine Lettuces. Some of the later plantings from this sowing may be covered with inverted pots after tying up. Fine large Lettuces can be preserved by this means up to the early part of the winter.

FRUIT GARDEN.

At this period a very general stopping of late growths and laterals should take place, both in wall trees and espaliers; it may, in the main, be accomplished by pinching off the extreme points. This is particularly necessary where it is desirable to carry out the dwarfing system. With regard to other fruits, however, there can exist no reason for suffering over-excited trees to continue producing wood, which can never be perfectly ripened, and which must be pruned away in the ensuing winter. The necessary consequences of this process are—first, a greater concentration of sap in the neighbourhood of the fruit; second, an inducement to the axillary buds to prepare for development; and third, the equalisation of the sap, thereby encouraging a greater uniformity of growth. In performing the operation with reference to the latter principle, the grossest of the shoots only should be stopped, leaving all the lower parts of the tree growing until the end of the season. Attend well to fruit trees of all kinds. Little superfluous wood should, if possible, be formed on tender fruit trees after the middle of August. Not only the fruit, but the wood, for the ensuing year, must be ripened. Even Apples, Pears, Plums, and Cherries are amenable to this law in some degree.

FLOWER GARDEN.

Let nothing be allowed to grow out of place, but attend to the wants of growing plants by giving them their proper supports and training at this season; the next matter requiring consideration will be the propagation of stock for another year. In commencing with *Pelargoniums* employed for bedding purposes, beds of sandy soil in the open ground will serve the *Scarlets* of all sorts and their allies, while the *Fancies* and other kinds with a delicate habit will be better in pots, or, where large quantities are required, in a frame under glass. Under any circumstances they will require protection from heavy rains. There is a class, of which *Sidonia* is one, which strike with difficulty by cuttings of the shoots, and are best propagated by root cuttings; prepare cuttings of the thickest roots about 1½ inch in length, which should be inserted in shallow pans and plunged in a frame; the old plants should be selected for the purpose. Herbaceous plants and hardy

bulbs now in full beauty should be kept in order by tying up loose growths and keeping the ground free from weeds. Novelties should have their colour, habit, and time of flowering marked down as a guide for future arrangements. Follow up Rose budding; those planted last winter, if they have not started well, must have a little more time. Care must be taken that all the decayed and withered petals of Carnations and Picotees are removed from those calices where the seedpod is formed. This may be ascertained by subjecting each to a gentle pressure of the thumb and finger. It will also be advisable to carefully split the calyx in order to prevent the lodgement of water, which is apt to take place when this is neglected. Proceed with all possible dispatch in layering, and prepare some good loam and leaf mould, well mixed, for potting-off the early-rooted layers, for, when sufficiently rooted, they are better away from the parent root; it gives them a check and prevents spindling. The old stools of Pinks will have now made considerable growth, and thrown up much grass; this will afford a second crop of pipings, and a large stock if required. If the plants have been grown in pots they may be turned out in the open border the first showery or suitable weather. It is advisable to preserve some old stools of few or scarce sorts, for, if well grown, they are often more steady in the production of well-laced flowers than younger ones, and they are also useful for producing seed. The beds of Ranunculuses, from which the roots have been taken up, should now be dug over and ridged up in order to sweeten the soil by exposure to sun and air. The soil, also, for planting Tulips should be carefully turned over, and all grubs and wireworms destroyed. Entrap by all possible means earwigs on Dahlias, and remove all misshapen buds as they appear.

GREENHOUSE AND CONSERVATORY.

Although flowers of all kind are at this period most abundant out of doors, yet some large and well-grown specimens of choice kinds will always furnish interest in the conservatory. To accomplish this, large shifts must be had recourse to, accompanied by improved modes of potting—viz., extra drainage, together with a greater reliance on turfy soils in a lumpy state, than upon complex composts. The climbers must at all times receive much attention in this house. Stopping gross wood is too much neglected. Above all secure a thorough freedom from insects, together with a most cleanly system. All this presupposes plenty of labour directed with judgment. Cut down Pelargoniums, pot off cuttings directly the roots are formed, and repot plants previously headed down as soon as they begin to break. Shift and sow Cinerarias and Calceolarias. Sow Mignonette for winter use. The stock of pot Roses should be looked over, useless wood and decayed blossoms removed, and the plants shifted; fibrous loam, night soil, and burnt earth may be used effectually. Camellias which have matured their flower buds may receive additional assistance either by soil or manure water, as circumstances allow. The common Anemone, potted three or four in a pot, and placed in a comfortable frame with the Neapolitan or Russian Violet in September, may be introduced to blossom on the shelves of the greenhouse during November and December. The common single Blood Wallflower, also, if sown in March, the leading shoots pinched out in June, and potted three in a moderate-sized pot, generally produces a good bloom through the dead of winter. Many more plants of this kind might be enumerated.

STOVE.

Those Orchids suspended in baskets or on blocks should have frequent handling as to their state of moisture. They will require a liberal supply at this period. All blocks will need frequent though light syringings. The business here is mere routine at this period; propagation matters having been attended to, together with high cultivation, little remains but to endeavour to perfect the wood already made. This must be accomplished by a freer circulation of air, and a somewhat less amount of atmospheric moisture.—W. KEANE.

DOINGS OF THE LAST WEEK.

WITH next to no water, for years we have never seen plants suffer more in a garden than they did on the 21st and 22nd inst., and even the 23rd was trying, though the air was cooler; and some slight signs were given, if not of a change, at least of a more vapour-laden atmosphere, as on the morning of Saturday we had a better deposition of dew than we have seen for two months. Many plants whose leaves were prostrate and

seemingly half dried up, revived and stood erect for a time on Saturday morning.

It is rather tantalising to read how some of our coadjutors and friends speak of what may now be done after "rain has come at last." From the beginning of the year we have scarcely had more than skiffs of rain—nothing to sink into the soil, nothing to replenish our exhausted reservoirs. Most of the rains have been very partial. During a day from home, in a space of some twenty miles, in three small places far apart, we found the roads in a puddle from next to a deluge, whilst immediately beyond this little spot we might as well have driven through the desert of Sahara. The absence of anything like a hay crop in this neighbourhood, though very trying to the holders of the land, will be lessened in its evils by the reported heavy crops in the northern counties. On our journey the other day from Luton to Oxford, with the exception of a few green meadows, we found the whole of that district had suffered from drought as much as our own neighbourhood. Even the princely Blenheim with its wondrous lake was no exception. The park grass crackled beneath our feet; the extensive lawns, except in shaded places, had scarcely a tinge of green. Even in such circumstances, though in many places the cereal crops were thin, in others, Barley and Wheat especially, seemed rather to be above the average—a pleasant thought for us bread-eaters, though liable to be greatly counteracted by this unlooked-for, hideous, and more than culpable war.

From all we could learn at Oxford we came to the conclusion that as respects the fall of rain, this has been an exceptional year. We recollect many years ago, in an early article in this Journal, alluding to the proverb, "Cart corn to the west, drive cattle to the east," based on the fact that the dripping weather of the western counties was so conducive to rich meadows, whilst the drier and sunnier atmosphere of the eastern counties was more favourable to cereals. This season, on the evidence of such men as Mr. Garaway, of Bristol, the drought has been felt severely in the west; whilst Mr. Carnichael, of Sandringham, spoke of the splendid crops in that naturally rather hungry district, owing to the frequent and abundant rains. Our recollections of Oxford and its gathering will be delightful, only possible to be enhanced if the visitors to the horticultural department had been three times the number they were on the first two days. Something in this respect may be owing to the neighbourhood, to the extreme heat and fierceness of the sun, to having the horticultural and the agricultural shows so far apart, and, perhaps, to having them at the same time at all. Many seemed to complain of the toil in going over, so as to "do" one of the exhibitions thoroughly.

Those who are interested in the watering question, will do well to correct for themselves an extract, as given about the middle of page 49, first column. It should have been, "Between March and May, we have much cold wet weather." As printed, the word "wet" is left out, to the derangement of the sense and argument. Great as was the outcry about general dryness, we found no case where there were less means of artificial watering than our own. Our small sources were very nearly exhausted on the two dread days above referred to. We knew if we could tide over until the 25th, we should have the chance of getting some, even if dirty, water, though other things were not neglected.

The chief work of the end of the week, was *mulching and shading*, the latter in the case of small plants coming in along with the first. For instance, we put rather short litter round Lettuces, young Cabbages, Cauliflowers, and Broccoli, not so protected before, fresh planted Strawberries, &c., and on many of these we sprinkled longer cleaner litter over the tops. Calceolarias showing signs of suffering, and which we would be sorry to lose for three months, and which in addition to mulching we could not litter without destroying their beauty, we shaded rather thickly with laurel boughs, firmly inserted and secured, so that even in wind they might not chafe against the flowers. The young growths of the laurels came in well for this purpose. A little water was given to individual plants suffering most. Everything under glass was given less air, and the glass more or less shaded, to keep out the drying heat, either with moveable coverings or a fair coating of whitened water. With everything looking well it seemed a pity that so many plants should be burned up, which they would have been, with our inability to water, and two or three days of burning, cloudless sun, such as we had on the 22nd. We hope to tide over until the 25th or 26th, when we may expect either more means or a change of weather. The gardener with a plentiful supply of water, knows nothing of the anxiety of him who has

a large establishment to serve, and every store of clean water exhausted. Some would say, Let the plants die and be done with, but that is poor policy, until every remedial measure is exhausted.—R. F.

TO CORRESPONDENTS.

•• We request that no one will write privately to any of the correspondents of the "Journal of Horticulture, Cottage Gardener, and Country Gentleman." By so doing they are subjected to unjustifiable trouble and expense. All communications should therefore be addressed solely to *The Editors of the Journal of Horticulture, &c.*, 171, Fleet Street, London, E.C.

We also request that correspondents will not mix up on the same sheet questions relating to Gardening and those on Poultry and Bee subjects, if they expect to get them answered promptly and conveniently, but write them on separate communications. Also never to send more than two or three questions at once.

N.B.—Many questions must remain unanswered until next week.

BLUE PIMPERNEL (Wild Flower).—This variety of the Shepherd's Weather Glass, or, as you call it, "Shepherd's Darling," is not uncommon. The following is an extract from our "British Wild Flowers":—"There is a variety with blue flowers, which has been regarded by some as a species under the name of *Anagallis carulea*; and there is another very pretty variety discovered by J. Dillwyn Llewellyn, Esq., of Penllergare, South Wales, which is pure white, with a purplish-pink eye in the centre of each corolla."

COCOA-NUT FIBRE REFUSE (E. M. P.).—You can obtain it from Messrs. Barsham & Co, Kingston-on-Thames. It is very cheap.

PHALIS EDULIS (W. Dickson).—This, commonly called the Cape Gooseberry, has been known for nearly a hundred years. You will find it figured and described in the "Botanical Magazine," vol. xii, t. 1068. It has been frequently noticed in our back volumes, particularly in vol. vii, old series, page 187, and there is a very full account of its culture by Mr. Beaton in vol. xv, page 250. As a material for cordage and paper, the plant, it is obvious, could not be grown in sufficient quantity in this country to pay. We shall be glad to learn your mode of culture, if different from that described by Mr. Beaton.

ADIANTUM (D. M.).—The date of Mr. Williams's book on Ferns and Lycopods is 1838. It would not pay to issue a new edition every year. Consult the "Gardener's Year-Book" for the most recent introductions. The part front of *Adiantum* enclosed belongs to *A. formosum*. We do not know *A. recurvum*. There is one named *A. curvatum*. The flowers of the Solanum Capsicastrum probably turn yellow and fall from want of water, a deficiency of air, too much heat, or imperfect root-action. We have ours a mass of berries in an airy greenhouse.

ADIANTUM PEDATUM (A Yorkshire Amateur).—It is a hardy Fern, and as such may justly be exhibited in a collection of hardy Ferns, though it would, of course, be disqualified if exhibited as a British Fern, it being an exotic. We cannot be positive without a specimen.

CUCUMBER LEAVES SCORCHED (T. Stenden, Southwark).—The leaf presents every appearance of red spider, but we cannot discover it. We think, however, it is the cause of the brownness of the leaves. We advise you to pick or cut off all the leaves like those sent us, and then syringe the plants with a solution of soft soap and sulphur, 3 ozs of the former and 1 lb. of the latter in three gallons of water, boiled for a quarter of an hour. Syringe with the clear liquid, and paint the sides of the frame, pit, or house with the sediment. Keep rather close, moist, and shaded from bright sun, and stir the surface soil, removing it if at all sodden, and replacing it with fresh. A sprinkling of water every afternoon at closing will be very beneficial, thoroughly wetting the leaves, but not very forcibly directing the water against them, otherwise they may be injured.

PRUNING HOLLIES (Norwood).—Having now made their growth it would be injudicious to prune the Hollies at this season. It would be best done in the spring of next year, when they are beginning to grow.

PEACH HOUSE PLANTING (H. D.).—In a house so narrow as 7 feet wide we fear you will not have space for a row of pyramids in front and trees on the back wall. For the front, if you have any trees, we should prefer espaliers or cordons, but not training them so high as to shade the trees on the back wall. If you have height in front, then by all means have pyramids. For pyramids or cordons, we should select Rivers's Early Beatrice, Early Louise, Early Rivers, Acton Scot, and Early York; and for the wall, Early York, Royal George, Noblesse, Grosse Mignonne, Bellegarde, Violette Hative, Barrington, and Late Admirable.

AZALEA LEAVES BROWNED (Julia).—The leaves sent us have no signs of having been attacked by insects, and we think they are scorched in consequence of the sun shining powerfully on them whilst wet. Admit air earlier in the day, so as to have the leaves dry before the sun strikes on the plants. A slight shade from bright sun whilst the plants are making new growth is necessary.

OAK FERN NOT THRIVING (Idem).—We think your Fern would do better if you were to cover it with a glass shade, unless it be in a cool, shady, moist part of a greenhouse, or in a fernery, where the glass is not needed. It requires a compost of two parts sandy peat, and one part limestone broken up rather small, and intermixed, with a free admixture of silver sand. Good drainage is necessary. It is essential that the plant should have a good supply of water when growing, and at no time should the soil be dry, but it is not good to sour it by too frequent and heavy waterings. A gentle sprinkling overhead during dry, hot weather, is very beneficial. It succeeds out of doors in a slightly shaded situation, and in a calcareous soil; the plant should be well drained, and be well supplied with water when growing. The cause of the fronds drooping and shrivelling is probably a too dry and draughty atmosphere.

STRAWBERRIES FOR A SANDY SOIL (Reader).—We have on a sandy soil Sir Joseph Paxton, Keens' Seedling, Rivers's Eliza, Dr. Hogg, Bicton Pine, and Frogmore Late Pine, with Cockscorb, all good. You may obtain them of any respectable nurseryman, but we must decline recommending dealers. Consult our advertising columns.

CUCUMBERS DAMPING-OFF (A New Subscriber).—The cause of the fruit damping is, no doubt, a deficiency of bottom heat, accompanied with too much moisture. We advise you to thin out the shoots, shortening those retained, which should be the most healthy, and those promising fruit. Those with or showing fruit should be shortened one joint beyond it, and we would cut off all the leaves which are at all yellow and browned. This will admit more air and light. Water so as to keep the soil moist—two or three times a week will be sufficient—and admit air early in the day, closing early in the afternoon. If you could give the bed a lining of hot dung, but not rank or fresh, it would assist the swelling of the fruit.

MANURING GROUND FOR ONIONS (Idem).—The seed bed for Tripoli Onions need not be manured, but the ground must be in good heart. When the ground is manured the plants are liable to grow too strong and do not stand the winter well; besides, they become thick-necked, and do not plant out well in spring and form good bulbs. The ground, however, in which you intend to plant them out in spring should be well manured in November, and then well dug or trenched, throwing the soil in ridges if at all heavy. In February or March, throw down the ridges in dry frosty weather, making the soil do, and you may before planting give a good dressing of powdered charcoal and point it in with a fork. Well-decayed stable or farmyard manure is most suitable.

HEATING A SMALL GREENHOUSE (C. A.).—We think that your slow-combustion Musgrave stove, ought to keep out frost from your span-roofed greenhouse of 18 feet by 10 feet, but in cold nights you should, before you go to bed, turn your slow combustion into a more active combustion, by admitting more air to the fuel. We do not know the size of your stove, but we have kept frost out of a house double the size of yours with a moderate-sized iron stove, but then we made its combustion of fuel subservient to our pleasure, making the combustion slow when we wanted little heat, and more active when more was demanded. A principle is good to act on, but we should not let it regulate every circumstance. If you cannot thus manage, then in your circumstances you had better have a small stove at each end of the house. We think one, however, if well managed, would be ample.

PEAR AND PLUM TREES SPURLESS (M. G.).—As the spurs of both Pears and Plums have so dried up and died on your old trees, but are still fruitful on the top branches, and the breastwood is, nevertheless, strong, we would cut out the strongest shoots, and lay in those of moderate size between the old branches. If these are stopped at from 18 to 24 inches, you may expect a few fruit buds the first season, and more the next.

MUSHROOM CULTURE IN A VINERY PIT (Cliftonensis).—You could have first-rate Mushrooms in the pit in the vinery whilst your Vines were at rest, and after being started until the temperature reached 60°. After that the Mushrooms would not do so well, unless you could keep from them the higher temperature of the house. The pipes below the bed for bottom heat, though not so bad in winter, would be rather unfavourable to them when you had a brisk temperature for Muscats.

EXHIBITING FINE-FOLIAGED PLANTS (E. P.).—We should prefer the *Cissus*, unless the *Alocasia* is a fine plant; if the latter is so, and the variegation well marked, it would have the preference. It is impossible to decide which you should show without seeing the plants.

DICKSONIA ANTARCTICA AND PTERIS ARGYREA (W. H.).—Both are exotic Ferns; the former a tree Fern from Tasmania, and the other from the East Indies. The latter requires the temperature of a cool stove or warm greenhouse. The *Dicksonia* thrives well in a similar temperature, and will succeed in a cool greenhouse fernery. The fragment of Fern from we think is *Dicksonia davallioides*, but we are not sure, as it is so small, and not in fruit. If it is that species it requires a greenhouse temperature, being from Australia.

LUCULIA PROPAGATION (A. B., Guildford).—Take cuttings of the young shoots when they are becoming a little firm, as they will be from mid-summer to the end of July, and insert them in sand over sandy peat well drained. It is desirable to place the cutting-pot in one of larger size, bringing the rims of both level, and then fill the space between with crocks to within an inch of the top, then with fibrous peat, surfaced with silver sand, and on this should rest a bell-glass covering the cuttings. Stand in a close pit or frame, and in a fortnight afford a bottom heat of 75°, and in six weeks they will have callused, but it will be the following spring before the plants can be said to be established in small pots, though when they are rooted they should be potted off. It is a plant that strikes root slowly, and makes but little progress in a young state.

MYRTLES NOT FLOWERING (An Inquirer).—As your plants grow freely, we conclude they have a too shady position; if so, all that is required to flower them is to place them in a light, airy position in the full sun, keeping them moderately dry, and we have no doubt they will flower next year. In the shade Myrtles grow well, but seldom flower.

IMPROVING LIGHT SANDY GARDEN SOIL (T. H. S.).—The blue marl which easily falls with the frost would vastly improve your garden. A good dressing of it spread on the surface after the crops are off, allowed to be acted on by frost, and then dug in, would be of more value than manure, though on sandy soils there must not be any stint of manure, that of a cool nature, as cow dung, being the most serviceable. As regards the Vine borders, we think the dressing with marl will also be advantageous, especially as the soil is very poor and light. Though light open soil is generally advised for Vines, yet there is danger in extreme openness and dryness of soil, as well as in adhesiveness and wetness of soil. It is well to have a dry in preference to a heavy border, as we can by top-dressings with bones, &c., vastly improve the soil's fertility. In addition to the dressing with marl, we would give a good top-dressing of equal parts of turfy loam, fresh horse droppings, a fourth of half-inch bones, and the like proportion of charcoal, all well mixed, and put on the border when the Vines are pruned.

ASTERS (P. E. J.).—It is no doubt green fly which troubles you in the cultivation of your Asters. It would have been easier to have prevented its appearance than it will now be to remedy it. Syringe them with a decoction of soft soap and tobacco, and keep them always well watered and growing freely; that is the great secret. It is in this that the

Parisian gardeners bent you—viz., the proper use of the watering-pot. Good, rather light, but rich soil, with an almost unlimited supply of water, is what Asters like. If they have this there will seldom be any green fly or curled leaves.

INSECTS ON VINE LEAVES (*J. Easton*).—We do not know how you packed your Vine leaf, but on the closest examination we could discover neither caterpillar nor red spider, and only found some little bits of red wax. Such a leaf should have been securely enclosed in oiled paper. We can hardly understand your allusions to red spider, in connection with caterpillars. This is just a season for red spider, where plenty of water could not be used.

INSECTS ATTACKING CONIFERS (*L. H.*).—The resinous swellings at the bases of the young shoots of your *Pinus insignis* are caused by the exodation of the sap, resulting from the attacks of the caterpillars of a small handsome moth (*Tortrix Buoliana*), which is now being produced in the perfect state, and which ought to be carefully sought for on the trunks of the trees and killed. Later in the season smaller swellings (caused by the caterpillars hatched from eggs deposited by the present brood of moths) should be looked for and destroyed. We found no insect on the small single shoot of *Picea Nordmanniana*. The shoots of the *Abies orientalis* and the *Spruce Fir* exhibit curious swellings like miniature Pine Apples, caused by the minute *Chermes Laricis*, a fly allied to the aphides, which is reared within the swellings. If they are so numerous as to become injurious to the trees, the swellings should be cut out, especially before the insects are developed, at which time the small scales which surround the swellings burst open to allow of the escape of the flies.—I. O. W.

NAME OF INSECT (*Chesham*).—The caterpillar sent by you is the remarkable one known under the name of the Lobster caterpillar. The moth is named *Stenoprota Fagi*.—I. O. W.

NAMES OF PLANTS (*Marten Cat*).—No. 1, of which we had preserved your flowering specimen, we now recognise as *Corous mascula*, popularly known as the Cornelian Cherry. No. 2, is the *Calycaanthus floridus*, or *Carolina Allspice*. (*Constant Reader*).—1, *Centraothus ruber*; 2, *Spiraea salicifolia*; 3, *Bryonia alba*, a poisonous plant. (*G. A. N.*).—1, *Escallonia rubra*; 2, *Jasminum odoratissimum*. (*E. H. D.*).—*Pelargonium alchemilloides*; *Escallonia rubra*. Your *Tropaeolum* has no merit to recommend it. (*A. W.*).—*Ocimum sphegiferum*. (*Flora, Guernsey*).—*Fatsia japonica*, more commonly known as *Aralia Sieboldi*. (*P. J. Newton*).—*Viola cornuta*; *Campanula crepitosa* of Scopoli, generally known as *C. pusilla*. (*W. H., Belbroughton*).—Your shrub is *Rhus Cotinus*, sometimes known as the "Burning Bush." (*An Old Subscriber*).—*Linaria Eliatine*. (*Thos. Pearson*).—1, *Goniolobium appendiculatum*; 2, *Pteris tremula*; 3, *Adiantum cuneatum*; 4, *Pteris cretica albo-lineata*; 5, *Pteris serrulata*; 6, *Asplenium bulbiferum*; 7, *Adiantum assimile*. (*A Young Gardener*).—*Gaultheria bracteata*. H. Jeffrey's "Rudiments of Botany," is the work we should recommend to you; its price will, we believe, be not more than 8s. 6d. Oliver's "Elementary Botany," published by Macmillan, is also first rate, and will cost about 8s. 6d.

POULTRY, BEE, AND PIGEON CHRONICLE.

THE MANAGEMENT OF POULTRY.

RECENTLY at a meeting of the Whitby Chamber of Agriculture, William Stonehouse, Esq., of Darnholme, himself a noted poultry-keeper and prize-winner, read the following instructive and amusing paper on the management of poultry:—

It was not without some misgivings that I needed to the request of Mr. Wilkinson to read, to the members of the Whitby Chamber of Agriculture, a paper on poultry. Knowing that, with farmers, and indeed with many others, poultry is not a popular theme; knowing also that Chambers of Agriculture usually apply themselves to the discussion of questions of greater importance, such as "The consideration of legislative enactments affecting land," "Leases," "Tenant Rights," "Rotation of Crops," "Deep versus Shallow Draining," "The effects of various manures upon different soils," and so forth; and knowing, moreover, that in this society, small though it may be in point of numbers, you have had able, and I might say exhaustive, papers read to you on local taxation, the adulteration of seeds and cakes, dairy farming, &c., I felt that you could scarcely be expected to descend so far as to listen to a paper upon poultry; for, somehow, poultry-keeping has come to be regarded as a somewhat ignoble pursuit, and a fit occupation only for women and children. If a man of mature age busies himself about, or takes any interest in poultry, he is looked upon as a sort of "harmless lunatic;" and anyone who, in later life, indulges in this hobby, must be prepared to endure a large amount of good humoured "chaffing" from his friends, who will crack stale jokes over him, and after inspecting his stock, will perhaps inquire if he does not keep any white mice, or monkeys, or racoons. At an agricultural show, your wives and daughters, your sons too, if they are not more than ten or twelve years of age, may visit and scrutinise the show pens in the poultry department, but you, yourselves, would almost blush to be seen there. Even the judges of horses, cattle, and pigs, at these shows, give the cold shoulder to the judges of poultry, and look down upon them as persons occupying an inferior social status. At one of the Whitby shows, some three or four years ago, sitting in the tent during the brief interval which is devoted to luncheon, the judge of horses was interrogated by the judge of sheep or pigs, or something else:—"I say, who is your chap, and what is he judging?" "Which chap?" inquired the judge of horses. "You chap with the white waistcoat," pointing out a gentleman who was, on that occasion, one of the judges of poultry, and who was of course conspicuously adorned with the proper badge of office. The judge of horses rested his eyes

for a moment or two upon the judge of poultry, a curious expression settled upon his features—an expression eloquent of contempt, and he delivered himself in this wise—"Him a judge—his's nea judge. He's nobbut a *chuckie greaper*."

Well, with a knowledge of this—may I say?—prejudice which exists against my feathered friends, there was an instinctive presentiment in my mind that this paper would have to be read to a "beggarly account of empty benches." At the outset, let me say that the paper possesses one quality—that of brevity—which, if it does not commend it to your favour, will, I hope, bespeak your indulgence and soften your criticisms. The supply of food for an ever-increasing population is a question fraught with deep importance, not only to the statesman and political economist, but to all who feel an interest in the future well-being of their country; and if it be true that he is to be regarded as a benefactor of his species who makes two blades of grass grow where one only had previously grown, then also, in like manner, must he be regarded who troubles and quadruples the produce of eggs and fowls, especially when, in these islands, our present supply of those articles is so inadequate to the demand that we have to import annually about five hundred million eggs, besides an enormous number of fowls, amounting altogether in money value to between three and four millions of pounds sterling; and is it not wise to inquire whether the productiveness of our poultry could not be developed and increased, so that these three or four millions of pounds sterling annually, instead of going into the coffers of our continental neighbours, might flow into the pockets of the English farmer? Does France possess any peculiar facilities for breeding and rearing poultry? for it is from France that much of our poultry produce is imported. I know of no advantage over England save that of climate, and that is not so great as it might, at first sight, seem to be, because it is not in the south, but in the north of France chiefly, that eggs and fowls for the English market are produced.

The secret of the success of poultry-breeding in France lies not so much in any superiority of the climate as in superior management. "They manage these things better in France" is a saying which is literally true with respect to poultry. There are in the northern parts of France large numbers of small holdings of land, and on those small holdings poultry-keeping is not infrequently the leading object of husbandry. The small farmer in France has found out that by the application of care and skill poultry-keeping pays well; and if the small farmer in England would devote the same time and attention to the pursuit, there seems to be no reason why it should not be equally remunerative to him. When we hear persons complaining that poultry-keeping does not pay, we should inquire whether any pains have been taken to make it pay; for when we know the way in which poultry is treated, or rather maltreated, in too many instances around us, we cease to wonder at these complaints. Any sort of a cockloft, without light and without ventilation, is considered good enough for a "hen house." The excrement from the birds is allowed to accumulate for twelve months, or sometimes longer; the walls are never whitewashed or cleaned. If you were just to put your nose into a house of this description some night when the birds had been roosting for a few hours, you would at once admit that it is impossible for poultry, under such circumstances, to do well. Then it is by no means an uncommon practice for poultry-keepers to send the chickens of each year to the market, and to keep the old hens for stock, instead of keeping the pullets for stock birds and killing off the old hens. Again, it is very seldom that any skill or judgment is exercised in the selection of stock; the birds are allowed to breed in-and-in, with little or no admixture of fresh blood, and as a necessary consequence the progeny become feeble and unproductive. In the pages of the *Field* and the *Journal of Horticulture*, two publications which contain much poultry intelligence, the question is often put—Does poultry-keeping pay? and if you read the letters which appear in answer to the inquiry, you will be amused and bewildered, some writers asserting that their fowls almost lay the fabled golden eggs, and that the shortest way to wealth is to take a large farm and stock it entirely with poultry. Others declare their fowls eat their heads off two or three times in the course of the year; that eggs cost them, at least, 1s. each; that such of their chickens as do reach maturity are the scraggiest of the scraggy; and that, in short, if you want to make ducks and drakes of your money, go in for poultry-keeping.

Desiring to eschew the exaggerated statements of these writers, and anxiously to guard myself against conveying the notion that I regard the poultry yard as a veritable "Tom Tiddler's ground," I do not hesitate to affirm that a limited number of poultry, if properly managed, will be as remunerative to the farmer as any other stock will be—that is, in proportion to the amount of capital employed. This is the testimony, after long experience, of many practical farmers, notably of Mr. Mechi, who maintains that his poultry are more profitable to him than his sheep. But perhaps you do not consider Mr. Mechi an infallible authority. At any rate Mr. Mechi's works prove the sincerity of his faith and words, and that is saying something, for he keeps upwards of three hundred fowls upon his Triptree Hall Farm, which are allowed, and indeed encouraged, to roam over the corn fields up to the time of harvesting, and in a letter to *The Times* newspaper he tells us that a field of wheat immediately adjoining the poultry yard, and which had been during the year the favourite resort of the fowls, yielded a larger amount of grain per acre than any other field on the farm. Mr. Mechi does not deny that the fowls eat some of the corn, but the loss

enstained in this way, he contends, is far more than over-balanced by the good which they do in destroying grubs and insects.

Well, then, we say, for poultry to be remunerative, there must be good management. And what constitutes good management? In the first place the poultry house must be properly constructed, sufficiently large for the birds contained within it, dry and warm in winter, and well ventilated in summer; it must be kept scrupulously clean, the walls whitewashed with lime two or three times during the summer; then there must be a bath-room, simply a dust heap, protected from the rain by a shed or covering, and open in front to the sun's rays. This dust heap should be composed of finely-sifted ashes, sand, or soil, and kept perfectly dry. Here the birds will constantly repair to luxuriate in their bath, and rid themselves of the numerous parasites to which they are much subjected. Of course, the birds must be fed, and fed at fixed times. If their meals are scanty, let them be regular. They must have a grass run, and a constant supply of pure water. When these few essentials are provided, poultry will thrive and do well; and surely when we reflect how useful these domesticated animals are to us, we must acknowledge that it is an imperative duty on those who keep poultry to supply them with whatever may be necessary to their health and comfort. In that admirable paper, read by Mr. Kerr a month since, admirable for the useful hints which it conveyed, there was much most of you could grasp and appreciate better than I could; but there was one portion which delighted me on account of the humane sentiments which pervaded it. Mr. Kerr deprecated all rough usage of cows, and pleaded for kind and gentle treatment. Let me put in a like plea for fowls. Certainly it is one of the most pleasing signs of the times in which we live, that kindly treatment of the so-called animal world is, among educated persons at least, fully recognised and taught, and we may hope that anything like cruel or harsh treatment of domesticated animals will soon be blotted from the things that be.

Then as to the particular breed of fowls which it is the most profitable to keep. If eggs are wanted, Hamburgs, or everlasting layers as some term them, are unquestionably the best; for young birds of this breed will lay, on the average, more than two hundred eggs each in the year; they are never broody, their eggs are small, but so long as the stupid custom obtains of selling eggs by number, instead of by weight, this circumstance inflicts no loss upon the seller, whatever it may do on the buyer. There are five varieties of Hamburgs—the Gold and Silver-spangled, the Gold and Silver-peucedil, and the Black. Mongrel varieties are to be found in almost every farmyard in the neighbourhood. They have an abundance of names, as Pheasants, Moonies, Dutch Chittrepts, Bolton Greys, and several others. When pure, with their markings perfect and regular, Hamburgs are very beautiful birds, but they are small, and not of much value as birds for the table.

If chickens are required, some other breed must be kept; and as to the best bird for this purpose, I suppose a jury of matrons would pronounce in favour of the Grey Dorking. Dorkings are large and heavy birds; their flesh is white and firm, abounding particularly on those parts which are most esteemed—viz., the breast, wings, and merry-thoughts. As chickens, they grow rapidly, and come to maturity early. These are qualities which commend them to all good housewives, and fully account for the character which for generations the Dorking has had as the table fowl, *par excellence*. Some writers claim for this bird a very ancient lineage, averring that the Dorking cock strutted on the British daggill when the Romans occupied this country. Dorkings are not prolific in the production of eggs, and they are unfortunately of a tender constitution, and will never succeed on wet or cold soils. If a fit of cold or wet weather assails their chickenhood, they droop and die with fearful rapidity. This is a serious drawback upon their merits, and poultry-breeders have long been seeking to find a table fowl which will combine the good qualities of the Dorking with a greater degree of hardiness. Game fowls are hardy and handsome; they are great favourites with many as table fowls, but they are small, and have, generally, a tendency to yellowness in the skin. Epicurians, however, assert that the flavour of a Game fowl is superior to that of any other breed; but, then, tastes are fanciful and capricious. A gentleman, well known to you all, keeps a breed of Game fowls upon his farm. His wife favours Dorkings, and, consequently, Dorkings are kept at the hall where these worthy folks reside. One day last autumn the lady and gentleman in question sat down to dinner, the bill of fare including a roast fowl, which was in due time carved and discussed. "Did this fowl come from the farm?" inquired the gentleman; the lady answered "Yes." "Ah! I thought so; I never tasted anything like it, the flavour is delicious. You may say what you like, but there's no kind of fowl equal to that of Game for flavour." "Except Dorkings," mildly suggested the lady. "Dorkings! pooh, pooh," says he, "they have no flavour at all." And then the lady laughed loud at her lord—"Why, my dear, this deliciously-flavoured fowl, which charms your palate so much, is a Dorking hatched at the farm from eggs which I sent from here." So you see how a person may be beguiled by his fancy.

A few years ago there was quite a mania for Cochins, which mania afforded the artists of Mr. Punch materials for a number of humorous illustrations; and Mr. Roelback, I remember, when he returned from France, on that memorable occasion when the Queen, accompanied by so many members of Parliament, paid a visit to the Emperor of the French, said "the 'Moscos,' in their peg-top trousers,

reminded him of nothing so much as a lot of Cochin-China fowls." Cochins possess many good qualities; they are hardy, are easily kept in confinement, and they are good winter layers; but as fowls for the table they do not hold a good position, the yellowness of their skin and fat is not prepossessing, and the flesh is coarse. The Hon. Mrs. Arbutnot some years ago—then Mrs. Ferguson Blair—published a little book, entitled "The Hen Wife," in which she strongly recommends, as decidedly the most profitable fowl for farmers, a cross between Grey Dorkings and Black Brahmans. Brahmans are large birds, very hardy; the flesh, if not so white as that of the Dorking, is said by connoisseurs to possess a peculiar juiciness, which is highly prized. They are quiet and docile; have no propensity to fly; they live contentedly and healthy in a confined space, and are never troublesome in getting into gardens or fields. As egg-producers they are commendable; not so prolific as Hamburgs, but then their eggs are much larger, and, like Cochins, they lay freely in winter. Their chickens are particularly hardy, and easily reared; the pullets commence laying early; they are capital mothers, and after hatching a brood of chickens will resume their laying within a month, and they are by no means such heavy feeders as Cochins. Mrs. Arbutnot recommends Brahma hens to be mated with a Dorking cock; from this cross table fowls may be obtained which, as she says, "look like young Tarkeys."

There is a very wide diversity of opinion among poultry-keepers as to what is the best food for poultry. In the winter season there is, perhaps, nothing better than barley, but in summer, and more particularly in hot weather, barley is too heating, and wheat, what is termed "tail wheat," is then much better. But whatever may be the main article of food, there should be a frequent change of diet. Indian corn, barley-meal and potatoes, turnips, and beetroot boiled, are all good for this purpose. In France buckwheat is almost exclusively used. It is cheap, and is considered by some authorities to be the very best poultry food. Lime in some shape must be provided, to furnish material for the construction of the shell of the egg.

The proper management of sitting hens is so well known, that it is unnecessary to say much on that head. Nature is the best and surest guide in such matters, and it is always the best to allow the hens to follow the direction of their own instincts as much as possible. Too much interference irritates the birds, and it often frustrates our success. To give an illustration. In February or March last year two or three of us—birds of a feather—met on the platform of the Whitley Railway Station, and straightway began to compare notes as to our poultry. Each, in turn, gave a recital of his ill-luck in hatching, and in summing-up and taking the average the result showed that we had got about one bird out of every ten eggs. Mr. Cooper, the station-master, hearing or surmising the subject of our discourse, accosted us—"You are talking about chickens, just come with me." We walked on to the goods station. "There," says Mr. Cooper, pointing with pardonable pride to a hen and seventeen chickens, "what do you think of that?" "Aye, what indeed! We had been reading and cramming ourselves with poultry lore, had been nursing our much-prized sitting hens with every imaginable care, administering their diet on the most scientific principles, lifting them off their nests daily, and sprinkling their eggs with tepid water, and, in short, using "all appliances and means to boot," only to reap the disappointment and mortification which I have mentioned; and here was a mongrel thing of a hen, which had "stolen her nest," as the phrase goes; secreting in some snug corner, she had deposited and hatched her eggs. She had been missed from her accustomed place, was supposed to have been stolen, when one morning she came back clucking with seventeen fine chickens at her heels.

You will meet with persons who tell you they can correctly predict the sex of the future chickens from the peculiar shape of the egg. Some eggs, as you know, are more elongated, and some more round than others, and the long and the round forms have been held to be each indicative of a certain sex. Others again, have pretended to discover the sex from the position of the air bubble at the larger end of the egg. These are all fallacies which have existed hundreds of years, and although proved to be fallacies hundreds of times, they still exist. Not only is it impossible to predict the sex, but it is impossible even to tell, before the egg has been set upon for a short time, whether it has been fecundated. A friend told me that the subject of determining the sex of the chicken beforehand was discussed at great length at an anniversary meeting of one of the Shipping Insurance Clubs in our town last winter—an odd subject certainly for a maritime party, reminding me by its very incongruity of an incident which occurred some time ago. A gentleman on going into the smoke-room of the Angel Hotel found two master-mariners in their shirt sleeves, engaged in fisticuffs. The combatants were parted, and, on investigation, it turned that their fight had originated in a difference of opinion as to "whether the Wesleyans or the Congregationalists had the better collection of hymns." But speaking of eggs, it may surprise some to be told that the strongest man in this room is not strong enough to crush an egg when it is placed endways between the palms of his hands. The shell of an egg is composed of small particles of carbonate of lime, arranged somewhat in the same manner as bricks, and placed in an arch, and have an enormous strength, but during the incubation the particles of lime lose that regularity of arrangement, and become confused, and the same egg, which before resisted your utmost strength, is now easily crushed by a child.

A great quantity of poultry is kept almost entirely for exhibition. Points of excellence in the various birds have been argued upon and laid down, by which they are judged. But, as perfection is rare, even in our species, so also it is rare in that of the gallinaceous, and many are the tricks and frands practised to remove blemishes, and to impose upon unsuspecting judges. The face of a Black Spanish fowl, for instance, must be of a pure white. If a faint blush of pink obtrude, or if a few straggling hair-like feathers show their unwelcome presence, farewell to all hope of a prize at a good show, so the owner of this bird paints the stains with some white substance, shaves off the obnoxious feathers, and probably carries off a silver cup, which, had the bird been exhibited in its natural and untrimmed condition, he would not have had the remotest chance of doing. In Brahmas and in Cochins one great object is to get birds with heavily feathered legs. Now this peculiarity is mostly, and as it would seem naturally, accompanied by a projection of feathers from the leg-joint, which is known as the "vulture hock," but the arbitrary taste of judges has decreed that this vulture hock shall be deemed a defect. The consequence is, that in scores of instances these hock feathers are skilfully pulled out, and the judges are imposed upon. Then there are smaller sins in the way of trimming. A Silver-Grey Dorking cock must have a breast of spotless black, but a few white feathers will come. Well, these are dexterously extracted, and then the bird is pronounced perfect. A Dorking cock's comb must be rigidly upright; a Dorking hen's comb must lop over; and all sorts of schemes are adopted to coax these combs into the required condition. I heard the other day of a gentleman who had two Dorking cocks—one a splendid bird except his comb, which would lop in spite of all that could be done to it; the other bird had nothing much to boast of except his comb, which was magnificent. Well, the two birds were brought together, an expert surgeon was summoned, who whipped off the combs, popped the perfect one on the otherwise perfect bird, and secured it in its new position by a few stitches. It struck, and grew, and flourished, and the bird subsequently achieved distinction as a great prizewinner. A clever case of trimming was exposed at a poultry show last winter. In the West Riding of this county there are two great rival poultry-keepers, more particularly rivals in Hamburgh breeding—Mr. Beldon and Mr. Pickles. Beldon generally takes the first rank, but last year Pickles almost invariably distanced his rival in Silver-pencilled Hamburghs. According to the standard of excellence the sickle feathers of the cock's tail in this breed must be black, or very dark, with a fine edging of white, and in this particular the superiority of Pickles's birds was conspicuous; and at the show in question they were awarded the first prize. Beldon has a poultryman named Job, and Job was of course put out at his ill luck, and stood ruminating before Pickles's prize pen. "His birds are not so good as ours if it wasn't for their sickles, but they're stunning sickles, certainly. I can't make it out how he manages to get them." Gaining the consent of the attendant, Job contrived to get hold of the bird with the wonderful sickles, and blowing into the roots of the tail feathers, when lo! the murder was out. "Well I'm blow'd," said Job, "fetch Mr. Hewitt." Mr. Hewitt, who was the judge of the poultry at the show, was soon on the spot, when Job pointed out to him how the natural sickle feathers of the bird had been cut down to the quill, and the beautiful artificial sickles neatly fitted into their place. Mr. Hewitt immediately cut off the borrowed plumes, and gibbeted Mr. Pickles, by affixing a notice to the front of the pen, fully describing the fraudulent transaction.

To prize-poultry breeders the annual show at Birmingham is the great event of the year, where some five thousand of the best fowls in the three kingdoms are exhibited. Among the exhibitors you have the royalty, nobility, and clergymen in great numbers, for your clergymen are generally good livers, and can appreciate fresh eggs and well-fed chickens; notwithstanding Sidney Smith, who says "Barndoor fowls for dissenters, but for the thirty-nine-times-articled clerk of the Church of England—the Pheasant—the Pheasant, and nothing but the Pheasant." I summed up the amount at which the birds were priced in the catalogue of the show of last year, and found it to be £40,000. In many instances no doubt these prices were intended to be prohibitory, but a single bird at the Birmingham Show will sometimes sell for a sum of money which would buy the best cow in this district. I saw a bird, it might be called a chicken, only nine months old, sold by auction for sixteen guineas, and with in the last eighteen months two birds have been sold from Whithy for ten guineas each.

Having kept poultry for about five years, and having kept also during that time a careful debtor and creditor account of my poultry doings, I can speak with the certainty acquired by experience as to the cost of keeping fowls. Even under the unfavourable position of having all the food to buy, and at retail prices, I have had the pleasure to find at the end of each year a small balance on the right side. The cost of the food does not exceed 1½d. per head per week. Then if you kill off the hens, say at the expiration of the second laying season—that is, when they are a little more than two years of age—the entire cost of keeping each bird up to that time will have been, in round numbers, about 15s. Now take the *per contra* side—each hen in those two years and odd will lay 250 eggs. I am speaking from my experience of Brahmas; Hamburghs will lay more than 400, besides hatching two or three broods of chickens, if you obtain a fair proportion of eggs during the winter season, and you may do so by contriving to have your pullets hatched early in the year. It will be fair to put down the price of these eggs at 1d. each, making £1 0s. 10d., and the hen, if put up to

feed for ten days or so, will not be dear at 2s. 2d., making a total of 23s. of receipts upon each hen, as against 18s. of expenditure. Then there is the dung, and you do not need to be told that the dung of fowls, when mixed with dry earth and pounded, is in value not far short of the best Peruvian guano. In this calculation I have not taken into account any of the notoward contingencies to which all kinds of stock are liable. Accidents will happen in the best regulated poultry establishments, but with careful management these should be few and far between.

With respect to Ducks, Geese, and Turkeys, I have not had much experience. I believe, however, that they are fully as remunerative as fowls; and except when very young, do not require so much attention. Ducklings and Goslings for the first two or three weeks, and Turkeys for six or eight weeks, are tender, and require great care; but when these ages are attained they are all hardy, and require comparatively little care or attention.

To conclude this desultory paper, and to epitomise, very briefly, the few practical suggestions which it offers—let me say to those who keep poultry, Be very careful in the selection of your stock. If your object be to produce a large quantity of eggs, keep some of the varieties of Hamburghs. If you require chickens for the table, keep Brahmas and Grey Dorkings. Keep young birds only. Introduce fresh blood into your yards every year, or at any rate every second year. Pay strict attention to the sanitary condition of your fowls. Give them, in short, the same care and thought which you would give to other branches of husbandry, and you will not much longer entertain the opinion that poultry-keeping does not pay.

Mr. S. Burn said he entirely agreed with many portions of Mr. Stonehouse's able paper, and with some portions he disagreed. For a length of time he had been one of those maniacs alluded to by Mr. Stonehouse (laughter), and he had certainly derived both pleasure and profit from the pursuit (hear, hear). He had been the fortunate owner of a chicken that was sold by auction at Birmingham for ten guineas, a result which had not been attained without some little care and attention. As a farmer's bird, he recommended a cross between the Brahma and the Dorking. Most farmers looked upon poultry as a department belonging entirely to the mistress, forgetting that if she did not rear the poultry and the poultry lay the eggs, they would have to give the goodwives money to make the marketing with. Lately, he (Mr. Burn) had superintended the poultry department of a farmer who thought he was not receiving as much from his grocer as he was spending in corn, &c. He (Mr. Burn) found that this individual had on his farm many of the same fowls that were there when he entered, and some of them must have been part of the original birds introduced into this neighbourhood. They had a general slaughter amongst them, some fresh birds were introduced, and the effect was so beneficial that poultry-keeping became much more profitable. The owner was astonished to find that by going on this improved system, it made about £30 a year difference. He brought about three hundred eggs to market every week, and had a large fine stock of poultry. He (Mr. Burn) had put this theory to the proof, for he had one six-year-old hen which had laid very few eggs, and he had another, a young Golden-pencilled Hamburgh, which had laid 204 eggs since the 1st of January. As to food, he entirely agreed with Mr. Stonehouse. The scraps ought to suffice, and poultry should be made the cleaners-up of the farm, except in winter time when they required feeding well. If farmers would feed their poultry well, they would find the benefit of it when eggs were 1d. each, and generally poultry was not sufficiently well fed. In France they had a moveable poultry house, which went on wheels from field to field. He believed farmers would find all kinds of poultry profitable if they paid the same attention to it as they did to other stock.—(Whithy Times.)

THE CANADIAN "POULTRY CHRONICLE"— HATCHING EXPORTED EGGS.

I HAVE received the first number of this new journal by last mail. It contains sixteen octavo pages, but the editor seems to have found some difficulty in filling up his first number. It is not stated in the "Chronicle" itself, but I learn from other sources that it is edited by Mr. McLean, Secretary of the Canadian Poultry Society.

The most interesting paper in this number is one containing the results of eggs imported from England, the number being fifty dozen, all from one breeder. The eggs were badly packed, and many were broken or altogether missing; nevertheless, the results were better than could have been expected. From twelve Brahma eggs the result was four chicks; twelve Houdan eggs, eight chicks, four of which were Black Hamburghs! as is remarked with good-humoured irony by the writer; from ten Pencilled Hamburgh eggs four chicks, with two dead in the shells; from twelve more of the same breed, seven chicks and one dead. The remainder of the consignment were not hatched at the date of the report.

I suppress the name of the exporter for the purpose of remarking that the purchaser complains strongly of his conduct in sending varieties not ordered in place of some he was

unable to furnish. The complaint is just; and it cannot be too strongly urged upon all doing any business across the water, that anything but strictly honourable dealing will infallibly lead to dissatisfaction, not to say disgrace.

By the way, I hear that Col. Hassard, R. E., is under orders for England, and has sold off his Canadian stock. If so, Canada will lose, and we shall gain, a most enthusiastic fancier. —L. WRIGHT.

THE TROUBLES OF EGG-HATCHING.

"EVERY chicken," said Mrs. Thorp to her sister, as they passed through a large stack-yard in which scores of young chickens were playing among the dry straw and hay seeds, "should live and grow through May, if it is to cost little, and be of worth to its owner."

"Don't speak to me, Clara, of May chickens, or, indeed, chickens of any month," replied her sister, "I cannot bear it. We have striven and failed, failed so completely that the sight of a feathered thing is distasteful to me. Frank spent more money last year over rearing his chickens than would have taken his own chicks and their hen mother to the seaside for a month. To think of the bother and trouble, and loss and death we had. I would not for anything go through it again."

"You might have better luck another time; my chickens are no trouble."

"Ah! but then you have had a world of experience, and you have a lot of old fowls at the farm to choose from, when you want one to hatch your fancy eggs bought at a fancy price; we had nothing but the market to go to, and the oldest, ugliest hen we could purchase at a dear rate, under the name of a clucking hen, was sure to have clucked her last before she reached our home. We were once nearly desperate, for we had half a score of big idle hens neither hatching eggs nor laying eggs, but walking up and down scratching and eating. What barley they did consume, to be sure! our man seemed to be always on the way to the nearest retail shop with a little white bag on his arm, and I cannot tell you how many sittings of eggs we had in the study laid up in baskets, and wrapped in cotton wool to keep them warm, and all these eggs had to be turned over daily. I never could understand the necessity of doing so, but yet I did it lest Frank should break them."

"But what were you doing to have so many eggs, and never a hen to sit?"

"We did not know the hens would not sit when we bought them. We were assured they would, that nothing could prevent their doing so, and like you we were determined to have May chickens. It was not to be; all about us eggs were hatching, in the old stone walls, and among the ivy, and rocking in the high thick branches of the sycamores; but our nests were empty. We could not walk out but we everywhere met with white or blue or spotted castaway shells, tell-tales of the new birds that had come to enrich the world; but our bird life lay dormant in the dark shell. We tried all ways reasonable, and I sometimes think unreasonable, to bring about the fulfilment of our desires; we put them in new nests, on lots of common eggs, and closed them up safe and fast, but they screamed and stamped and broke the eggs, and finally escaped. They would neither be coaxed nor driven; if you went near them they flew about like wild birds."

"You must have been deceived in the hens you bought. I have had them from a long distance, and they have done well."

"Have you? You are a farmer's wife, and understand such things. If I were troubled with a lot of sitting hens—I never shall be, though, if I can have my will—I would take them out for a drive, or hire lodgings at a strange place, and bring them home after a time. I am sure it would cure the most stubborn Cochins that ever dared to sit at an unreasonable time."

"But the Cochins I sent you, did she not do well?"

"Yes, she did very well, but she had no chicks. We thought to be wise and just, that it was first come first served, so gave her the oldest eggs, some Black Spanish that had cost a great deal of money. I do not know how old they were, but I had turned and re-turned them over and over again for many weeks—I cannot tell you how many; but I remember when I first took upon myself the important work, the starlings were building in the barn roof, and when I turned them over for the last time, they were popping large worms down the wide throats of their noisy youngsters. No life would come out of the shells. Frank said they had been dipped in hot water, or pricked through with a pin, or some one had played Columbus with them to a purpose."

"Your wisdom was at fault, Emily, for once; a few fresh eggs from the nearest farm would have done better for you, better for my poor hen."

"But what a mongrel tribe they would have been—all colours and shapes. I do not like common barn-door fowls; they may be all very well about cottages, but in a poultry-yard devoted to their use, they should be all of a sort, and of one colour."

"They would have made a settlement for you, a nursery in which to rear delicate birds, all of one colour, and so nearly resembling each other that you could not distinguish one from the others, if that is your desire. I would rather have the beauty of strong young life, than that of plumage apart from strength. I am afraid that many would rather their white birds were delicate of constitution, than betray one coloured feather. And then, too, the blame of failure is often thrown upon the hen or the eggs, when in truth it rests with ourselves. We cannot let well alone, we go groping about the nest, it is never deep enough, or soft enough, and we irritate the poor bird, until in disgust at our proceedings she forsakes her eggs—perhaps if we are fortunate to hide away her nest, and bring home, to our delight, such a brood of chickens as could not have been if our curious eyes and busy fingers had intermeddled with her. Fowls of all kinds are very distrustful of human help; by long patience, gentle tones, and quiet movements, do we alone win their confidence, and even then they are apt to regard us as giant marauders, taking our spoils after a wholesale fashion, and no outrage which the strong ever perpetrate on the weak is equal to stealing away the eggs from a secret nest. My wonder never is, that there are so few chickens hatched, but that there are so many. We nurse and coddle, and shelter our sitting hens from a drop of rain, a breath of fresh air, or a glimpse of sunshine, as though these powers were set to fight against our success, and yet we know that the rain often drips through the blackbird's nest, and the long grass and dead fern fronds that hide the pheasants are wet with dew, and yet their little ones come and thrive. But many think that they can do better than work with Nature. I have seen poor hens shunt up in little dark places, deprived of their daily walk and bath, with food to eat and water to drink, but no space in which to use their limbs. A weary three weeks they must have, a sad negation though not of their own choosing, for they would make all the way of their life bright and glad. The healthy chick comes with gladness into the world, and of all sufferers they are the most patient."

"Really, Clara, I never thought there was any need to consult their feelings and inclinations. I used to think if a hen wanted chicks she would hatch them in any place, and under any circumstances. I know now to my cost she will not always do so."

"And suppose that she would, in what condition would she be when her three weeks' imprisonment was over? Would the dark airless nest have given, or kept, an appetite? And with its loss surely health and spirits, and warmth would have fled. Then wonder would be expressed that the poor bird grown tame and quiet, did not teach her chicks to play. How little do the wisest know of the ailments of birds, and yet we all know that a vigorous healthy growth can only be produced under the happiest circumstances; therefore, we are diverging in no wrong path when we surround our poultry with what is needful for pleasure and comfort."

"No wonder Frank and I failed. I must own we thought more of our new poultry-yard than our poultry, but we tried over and over again. We had a sitting of Dorkings, and were lucky enough to get a hen to sit them; she did well, and our expectations ran high; the proper time passed, the shells remained unsnipped, though we could feel the throbbing of life beating strong within the eggs when they were held in the palm of the hand. Some one told Frank they were too dry, and if left to their fate would all perish in the shell, so a gallon watering-can filled with tepid water was brought, and its contents poured over them; the water ran in little rivulets all among the white eggs, and settled in a pool in the hollow of the nest, and I thought surely they would be drowned. It did no good; when morning came they lay a cruel sight, all dead, some in the shell, some out. It was a great disappointment to be so near to success, and yet to fail. Frank declared that he would have the next batch brought in-doors, and sit up with them all night, but he would save them. Our next were Hamburgs, from the breezy Yorkshire moors. They promised well; night after night we held them before the lamp to make sure they were not deceiving us; all were dark, not one remaining clear; seventeen of them had the big Cochins, and we had left her in a

moveable nest of her own choosing out in the poultry-yard. A long dry season was broken up by a thunderstorm, which threatened to leave a rainy night; fearing for the safety of our coming chicks, we took nest and eggs and hen into the poultry house. I felt glad to think all night they were safe from harm. Next day the Cochin was found comfortably squatted on the very spot where her nest had stood before being moved, not in the least caring for the falling rain, and her eggs were forsaken, they had been cold for hours. She never took to them again. We had no need to sit up all night. A week after our dis-appointment reached its height, we had what was said to be a Brahma hen hatching eight Brahma eggs. Frank was in Ireland, and I was determined they should not be in any way played with; they should do as chickens did in the days of our grandmothers, find their way unaided into the world, the strong should live, and the weak die; better to do so at once than after eating eggs and bread for weeks. Ah, me! Your little four-year-old namesake, Clara, came to me one morning with her pinafore held tight, exclaiming, 'Oh! Aunt Emily, your great yellow hen has laid such a lot of soft yellow eggs, only see.' They were my long-expected chicks; her small fingers had stolen them from their sleepy mother, and grasped them much too tightly; five were dead, she had but six; the one remaining would not die, though I much wished it would, but for months trotted on the sheltered side of its mother like a March lamb. It was all over with bird hatching. I sent the unused eggs into the kitchen for the cook, but she looked at them, smelled at them, and was quite sure they would not do for cakes or puddings, they were not fresh enough. Frank says 'He will try again.' I hope not."—MAUD.

EXPORTING FOWLS.

DURING the past three months I have received many American orders for fowls, and though I shall be able to supply very few if any of them, I have had to make inquiries on the subject in consequence, the results of which may be useful, and save some time and trouble to other readers of "our Journal," who may be desirous of supplying the American market.

There is only one line of steamers I believe, the Guion, which takes live birds, and the vessels of which sail every Wednesday. As far as I can ascertain, the most convenient plan is to employ the American-European Express Agency, of Messrs. Staveley and Co., the Temple, Dale Street, Liverpool, who will make all arrangements for care and feeding, and, in fact, take the sole charge of the birds from Liverpool, if delivered to them carriage free, by Tuesday afternoon, with all advice and instructions a post before.

The freight and charges from Liverpool can, if desired, be carried forward to consignee, in which case a small per centage extra is charged on account of the risk. The mortality is, however, on the average very small. The freight and charges to New York will vary from about 35s. to £2 10s., for a pen of three fowls, according to their size.

The birds should be sent in strong wooden pens or coops of proper size, with the top of a good slope to throw off wet, and only open in front. There should be fastened at the top of the open side a strong piece of canvas, to draw down in bad weather. The floor ought to be a few inches above the ground, and slightly sloping, and handles for lifting must also be provided. The size for three birds may vary from 2 to 2½ feet square, according to the breed, and the front is, of course, to be so arranged that the floor can be scraped easily.

The food of sea-going birds I find is usually mixed with a portion of sand to assist digestion.

The customs duty levied at New York is 20 per cent, *ad valorem*, on the net price of the fowls, and a very stringent declaration of the real value is required if declared by the consignee; but if the purchaser resides near New York, it may be best to let him declare the value, which may be done. This heavy duty is most oppressive, and endeavours are being made now to reduce or remove it, as being a great hindrance to the improvement of poultry in the United States. I believe American fanciers are not without hope these efforts in favour of a free trade in fancy fowls may be successful.—L. WRIGHT.

CURE FOR ROUP.

THIS deadly disease is of such continual interest to all fanciers that I have thought it well to copy, for English readers, a new prescription from the New York *Poultry Bulletin*. Some may

think this hot weather (it is 92° in the shade with me), an odd time to mention roup, but I think differently; the first change of weather will be so sudden a transition that many severe cases may be expected.

The prescription consists of one ounce balsam of copaiba and one drachm piperine made into sixty pills. They should be enclosed in gelatine capsules, or the medicine will be very difficult to administer. Two or three capsules or pills are to be given daily, and the head and eyes washed with a solution of a teaspoonful of sugar of lead to a pint of water.

This remedy appears to me extremely likely to be effectual; and Mr. M. W. Lawrence, who gives it, states that he has used it in over a hundred cases with complete success.—L. WRIGHT.

WESTWARD HO! POULTRY SHOW.

ALTHOUGH under a disadvantage from being held so far from the majority of poultry-breeders, the Westward Ho Exhibition has gradually increased in importance, until the Show this year was a most creditable one. The increase in the number of visitors from year to year is really surprising—so much so, indeed, that it was calculated that from ten to twelve thousand persons were on the grounds at one time. The Show is held close to the beach, and the natural beauty of the coast, and the gaiety and fashion of those who attended, rendered it most attractive. The general arrangements were most creditable. Although a matter for which the committee could not be blamed, we think it well to call attention to a mistake in the arrangements of the railway companies that cannot be otherwise than most prejudicial to their own interests, and which may well exasperate the owners of valuable show birds. We allude to the folly we have so frequently exposed of placing show poultry and show dogs in the same van during transit. In the present case, a fox terrier, the breed of all others which is the most prone to commit mischief, tore to pieces her own basket, and then ate away the basket containing some valuable fancy Pigeons, killing two pairs of birds that it would have been difficult to replace on any terms. In the case at Bideford, luckily the journey was completed before all the mischief that might have been done was accomplished, for, as the party in charge of the dog stated, "If we'd had to go another mile or two farther, not one would have been left;" and for the information of our readers we may mention that the Pigeons' basket being once broken, it was most fortunate that out of twelve pairs only two pairs were sacrificed, for, but for this timely discovery, all would beyond question have been destroyed. The tents for both were very superior, and every attention was paid to the welfare of all the specimens exhibited. The repacking of the birds was also carried out with promptitude.

First-rate Grey *Dorkings* were shown, and among the White *Dorkings* were a few isolated specimens of extraordinary worth. *Brahmas* were poor, but *Cochins* and *Gamb* fowls were much better than had been previously exhibited in this district. *Hamburgs* did not reach our expectations, but some good *Polands* were to be met with. The class for the best Barn-door cock and hen brought together a most incongruous though large entry, and in this, as also in the "Any other Variety" class, some unusually good Malays were entered. There was a class for "chickens of any breed" of the current year, in which some of the most forward specimens we have seen this season were competing. The first prize in this class went to Duckwings, the second to a pen of good Partridge-feathered *Cochins*, and the third to Light *Brahmas*. It is evident that a great advantage arises from the mildness of the early months of the year in this neighbourhood, and the development that ensues is rapid, from the chickens not meeting those sudden checks from change of atmosphere, which, to the sorrow of too many breeders in the northern counties, cause malformations of the extremities.

DORKINGS.—*Colour* L.—1, Mrs. A. C. Thynne, Penstowe, Stratton. 2, Rev. G. F. Hodson, North P. therton. 3, Mrs. P. Coffin, Penpercombe. *hc*, Miss J. Milwood, Newton St. Lee, Bristol. *White*.—1 and 2, W. Pickard, Hartland. 3, —Hammett, Bideford. **SPANISH**.—1, S. R. Harris, Cuscaro, near St. Day. 2, G. Tonkin, Bristol. 3, J. Jow, Bideford. *c*, Mrs. E. Smith, Camboay, Tavistock. **B. Brewer, Lostwithford, GAMB.**—1, G. S. Crawley, Crawley Borchard. 2, S. R. Higham, Moreland Bishop. 3, J. Westcott, Barnstaple. *hc*, J. Boyles, Barnstaple; G. S. Crawley (2); R. Stephens, Ilfracombe; S. R. Higham. **COCHIN-CHINA**.—1, F. Brewer. 2 and 3, W. S. Trewin, Kilkhampton. *hc*, J. Long, Plympton. *c*, Miss J. Milward. **BRAHMAS**.—1, Mrs. A. C. Thynne. 2, Mrs. Gordon, Instow. 3, Mrs. E. Smith. **HAMBURGERS.**—*Gold-spanish*.—1, S. R. Harris. 2, S. Woodman, Barnstaple. 3, J. Oliver, Bideford. *Gold-pencilled*.—1, S. R. Harris. 2 and 3, J. W. Francis, Bideford. *Silver-spanish*.—1, S. R. Harris. 2, J. Woodley, Stratton. 3, L. Withecombe, Buckland Brewer. *Silver-pencilled*.—1, S. R. Harris. 2, J. Turner, Abbotsham. 3, J. Walters, Bideford. **POLANDS**.—1, T. Jacobs. 2, Miss Webber, Exeter. 3, Mrs. E. Smith, Barnstaple. 4, D. Barrable, Paize, Bade. 5, A. C. Trewin. *hc*, L. Withecombe. *c*, W. Birdwood, Glenburris. **ANY OTHER VARIETY**.—1, H. Lowthry, Newport (White Spanish). 2, Mrs. E. Smith (Cove-Cour). 3, S. Veale, Langley, Villars (Malay). *hc*, J. W. Francis; B. Britton, Bishop's Cleeve, near Barnstaple; R. Mitchell, Bideford. *c*, F. Glover, Bridgerule; J. F. Yelland, St. Giles, near Gt. Torrington; G. H. Hackwell, Collocott, Langtree; W. Trewin. **COCK**.—1, S. R. Harris. 2, W. Masland, Milverton, Somerset. 3, J. Heale, *Chickens*.—1, S. R. Higham. 2 and 3, J. N. Nicholls. *hc*, Mrs. Gordon; N. Trevelyan; Mrs. P. Coffin. **BANTAMS.**—1, W. How. 2, S. Woodman. 3, E. A. Bazley, Bideford. *c*, C. Veal. *Any other Variety*.—1, Rev. G. F. Hodson (Gold-laced). 2 and 3, G. S. Crawley; J. Blacks and Gold-laced. *hc*, S. Woodman. **TRING**.—1, Mrs. How. 2, Miss S. H. Northcote. **UPTON PYNCE**. 3, Mrs. P. Coffin. **DUCKS**.—1, T. E. Hawken. 2, S. R. Harris. 3, J. Heal, Parkham. *Common, or any other sort*.—1 and 3, Miss Turner, Coombe, Abbotsham (Mescovy). 2, Miss Webber, Exeter (Carolina). **GEES**.

—1, 2, and 3, J. Heald, *hc*, L. Withecombe; J. Sanders, TURKEYS.—1, Mrs. A. C. Thymne, 2, J. Heald, 3, W. Fridham, *hc*, E. Smith.

PIGEONS.

CARRIERS.—1, H. Yardley, Birmingham, 2, J. Chapple, BAPS.—1, W. Westcott, jun., 2, Andri, J. L. Smith, 3, Messrs. J. & C. Bullen, PORTERS.—1, H. Yardley, 2, Miss Macgregor, FANTAILS.—1, H. Yardley, 2, J. T. Sleath, *hc*, T. A. Pearce, JACOBIANS.—1, W. Westcott, jun., 2, No competition. TRUMPETERS.—1, J. A. Sleath, 2, W. Masland, Milverton, 3, H. Yardley, TUMBLERS.—1, H. Yardley, 2, W. Westcott, jun., TURNITS.—1, H. Yardley, 2, G. H. Gregory, Tampton, NEWS.—1, H. Yardley, 2, Messrs. J. & C. Bullen, COMMON.—1, H. Heald, Beaford, 2, M. Olde, Didas, Stratton, EXTRA.—1, J. S. Sleath, 2, J. Chapple.

RABBITS.—1, H. J. Parsons, 2, S. Vinnicombe, 3, J. Darch, Bideford, *hc*, Miss S. H. Northcote.

The Judge was Edward Hewitt, Esq., of Sparkbrook, Birmingham.

HASLINGDEN POULTRY SHOW.

The following awards were made at this Show, held on the 21st inst. :—

COCHINS.—*Dark*.—1 and 2, W. A. Taylor, *hc*, J. Siebel, *Chickens*.—1 and 2, W. A. Taylor, *hc*, C. Sidgwick, *Any other Colour*.—1, W. A. Taylor, 2, J. Siebel, *hc*, J. Robinson, jun.; T. Strothe, *Chickens*.—1, G. Lamb, 2, C. Sidgwick, BRAMMS. *Dark*.—1, J. H. Pickles, 2, E. Leech, *hc*, H. Lucy, *Chickens*. 1 and 2, W. A. Taylor, *hc*, F. Leech; G. Anderson; W. Harvey, DORKINGS.—1, J. Slat, 2, J. Watts, *Chickens*.—1, J. Slat, 2, 1; 3, C. Haworth, *hc*, T. Briden, T. Statler, FURNIVOLLS.—1, H. Beldon, 2, J. WARD, SPANISH.—1, F. & C. Haworth, 2, C. W. Brierley, *hc*, H. B. Smith; H. Beldon, *Chickens*.—1, C. W. Brierley, 2, H. Beldon, *hc*, E. Brown, GAME.—1 and 2, C. W. Brierley, *Single Cock*.—1 and 2, C. W. Brierley, *hc*, T. Statler, LOCAL PRIZE.—1, A. Sutherland, 2, Eastwood & Hindle, 3, J. Smith, HAMBURGERS.—*Gold-pencilled*.—1, H. Pickles, 2, S. Smith, *hc*, H. Beldon, 3, J. Andrew, *Chickens*.—1, J. W. Wrixley, 2, H. Beldon, *hc*, H. Pickles, 3, W. S. Schofield, *Super-spangled*.—1, F. & C. Haworth, 2, H. Beldon, *hc*, and H. Pickles, *Chickens*.—1 and 2, H. Pickles, *Gold-spangled*.—1, N. Marlor, 2, J. Newton, *hc*, W. Driver, 3, H. Pickles, *Chickens*.—1, J. Andrew, 2, E. Brierley, *Super-spangled*.—1, H. Beldon, 2, H. Pickles, *hc*, J. Fielding, *Chickens*.—1, H. Pickles, 2, J. Fielding, *hc*, G. & J. Duckworth, 3, J. Fielding, *Black*.—1, N. Marlor, 2, S. Sidgwick, *hc*, Masin & Walker, *Chickens*.—1, C. Sidgwick, 2, Masin & Walker, *ANY OTHER VARIETY*.—1, H. Beldon, 2, W. Harvey, *hc*, T. Briden, 3, H. B. Smith, BANTAMS.—*Game*.—1, T. Sharpley, 2, W. F. Entwistle, *Single Cock*.—1, G. Haworth, 2, Harwood & Buckley, *hc*, W. F. Entwistle, *Any other Variety*.—1, J. Walker, 2, S. & R. Aslton, *hc*, J. Watts, TURKEYS.—1 and 2, E. Leech, *hc*, C. W. Brierley, GESE.—1, F. Leech, 2, T. Statler, jun., *Any other Variety*.—1, C. W. Brierley, 2, H. B. Smith, 3, S. & R. Aslton; *hc*, W. Brierley, T. Statler, jun.

PIGEONS.

CARRIERS.—1 and *hc*, E. Horner, 2, H. Yardley, TUMBLERS.—1, J. Fielding, jun., 2, E. Horner, *hc*, J. Fielding; W. Harvey, 2, PARES.—1, E. Horner, 2, H. Yardley, *hc*, E. Horner; J. Fielding, jun., 3, W. Harvey, OWLS.—1, J. Fielding, jun., 2, W. Harvey, *hc*, J. Fielding; J. Hawley, CROPPERS.—1, E. Horner, 2, W. Harvey, *hc*, E. Horner; W. Harvey; J. Hawley (2), FANTAILS.—1, W. Harvey, 2, E. Horner, *hc*, E. Horner; H. Yardley, TURBITS.—1, E. Horner, 2, J. Fielding, *hc*, E. Horner; F. Moore, DARGOONS.—1, H. Yardley, 2, T. H. Freer, *hc*, W. Harvey, 3, J. Watts, TRUMPETERS.—1, E. Horner, 2, J. Hawley, *hc*, W. Harvey, JACOBIANS.—1, E. Horner, 2, W. Harvey, *hc*, F. Horner; J. Hawley, ANTWERPS.—1, E. Horner, 2, S. Fletcher, *hc*, H. Yardley (2); J. Oldroyd (2); J. Watts; J. Hawley, *ANY OTHER VARIETY*.—1, J. Hamilton, 2, H. Yardley, *hc*, W. Harvey; E. Horner (2), LOCAL PRIZES.—1, J. Hamilton, 2, J. Kemp, *hc*, J. Hamilton; H. Madlam.

RABBITS.—*Long-ear*.—1, C. Gravid, jun., 2, J. P. Sly, jun., *hc*, W. Higham; F. Vaughan, *Any*.—1, D. Kenyon, 2, J. Butterworth, *hc*, *Woolly*.—1, W. J. Butterworth, 2, A. L. Rawstron, *hc*, J. Boyle, jun., *Any other Variety*.—1, J. Lenn, 2, J. Butterworth.

JUDGES.—*Poultry*: Mr. R. Teebay and Mr. Hindsen. *Pigeons*: Mr. Charlton.

(From a Correspondent.)

RABBITS.—These, as a whole, were good, but I regret that not more than twenty-six were shown, and more ought to have been shown, seeing that four classes were given, and the prizes if not so valuable as at some shows, were sufficient to have attracted more entries. Few exhibitors are induced to enter their Rabbits solely because of the value of the prize, so long as it is adequate to pay all expenses if won. Honest judging, and great care taken of the specimens, are great inducements to exhibitors. The pens at this Show were large and well supplied with oats, straw, and hay, and I may add, as a hint to all committees, that the feeding is very important, considering the length of time some of the Rabbits are away from their hatches. In this instance some I know did not reach home until 6 p.m. on the day following the Show. Carrots and turnips are cheap enough, in the absence of oats, &c.

The first-prize pair of Yellow and White Lop-eared, belonging to Mr. C. Gravid, of Thorne, fully deserved the position they took, being a splendid pair. A little more and equal sprinkling of the white would, perhaps, have rendered them more perfect. Length of ears, doe 21½ inches by 5½ wide; buck, 21½ inches by 5½ wide. The second-prize pair from Mr. J. Boyle, jun., Blackbar, were Black and White; a pair of Grey and White, of Mr. Walter, Higham, Middleton, and a pair of clear Fawn, sent by Mr. Vaughan, Market Hall, Birmingham, were also highly commended. The first-prize Angoras of Mr. D. Kenyon, St. Leger Yard, Acerrington, were larger, perhaps, than the second-prize pair from Mr. J. Butterworth, Rockdale, but not so silky and long in the hair, and that is the important point with this variety. The first-prize pair of Himalayan from Mr. J. Butterworth were well marked, and as good in points as could be desired. The second-prize pair of Mr. Rawstron, Haslingden, were a nice pair, and the highly-commended pair of Mr. James Boyle, I think, must have given the Judge a little trouble before arriving at his decision. Of the Silver-Greys in the "Any other variety" class, the first-prize pair from Mr.

John Lunn, of Hull, were not so beautifully silvered as the second-prize pair from Mr. J. Butterworth, perhaps a little larger, and if only five months old, as stated, they were too young, perhaps, to be fully shaded or exhibited. The Judge, Mr. T. Charlton, 51, Trafalgar Street, Bradford, I think, may be commended for the justness of his awards, except where, I think, a little more careful handling of one or two of the specimens might have caused the prize cards to have been fixed upon other pens. The exhibiting of Rabbits in pairs tests a man's rabbitry, as single good ones can often be found, but to pair them with others equally good in all points is at times difficult. Again, all white Rabbits, as a rule, appear to disadvantage in pairs, especially the Angora, not looking so clean as when alone. I hope Haslingden will find next year, with the care bestowed, that the Rabbits will appear in great numbers, and I trust this improvement upon last year will induce owners to send their specimens.—C. R.

PONTEFRACT POULTRY SHOW.

The thirteenth annual show of poultry took place in the park on Thursday, July 21st, and the weather being all that could be desired, numbers came to witness the best show ever held in Pontefract.

The *Dorkings* were not numerous, but were in excellent condition for the time of year. The *Spanish* class was rather small, the first prize being taken by Mr. Newbitt, of Epworth, with a very good pen. The *Cochins* were an excellent lot, but greatly out of condition. The *Brahma Pouter* class was unusually large, and there was some difficulty in making the awards, owing to most of the birds being first-rate. The *Hamburgs* were not up to the mark. In the *Game* classes there was severe competition, a pen of Brown Reds from Mr. F. Sales, of Crowle, taking the first prize, as being the best pen in the show. The *Game Bantams* were rather large, but many of the best birds were not in condition. The chickens of 1870 were very numerous, the Society offering a much larger prize than for older birds. The first prize went to a pen of excellent Brown Reds. Below will be found a list of the successful competitors.

DORKINGS.—1, J. Barraclough, Ackworth, 2, W. B. Arundel, Transhell Lodge, SPANISH.—1, Messrs. Newbitt, Epworth, 2, Messrs. Pickard, Thorne, *hc*, W. B. Taiton, Ackworth, COCHINS.—CHINA.—1, Miss A. Moxon, Pontefract, 2, Messrs. Pickard, BRAHMA POUTER.—1, Lady Hawke, Womersley Park, 2, T. Addy, Asker, HAMBURGERS.—*Gold-spangled*.—1, J. Barraclough, 2, W. Jefferson, Pontefract, *Any other Variety*.—1, J. Wardell, Ackworth, 2, J. Barraclough, *Silver-spangled*.—1, J. Wardell, 2, J. Armer, Methley, GAME.—1, F. Sales, Crowle, 2, J. Greenwood, Featherstone, *hc*, H. Poskatt, Darrington, BANTAMS.—*Game*.—1, J. Warriner, Sandal-Magna, 2, H. Harrison, Pontefract, *hc*, Lady Hawke, *Any other Variety*.—1, Messrs. Newbitt, 2, A. E. Fox, Pontefract, *ANY OTHER VARIETY*.—1, W. Dooly, Ackworth, 2, F. B. Brank, Campsall Hall, *Chickens*.—1, F. Sales, 2, —, Pickard, *hc*, E. R. Frank (2), *Cock*.—1, W. B. Taunton, *Cochin China*, 2, F. Sales, *Black*, *Extra*, 2, Messrs. Newbitt, *Spanish*, DUCKS.—*White*.—1, Master W. Kenworthy, Ackworth, 2, D. Longstaff, Monkroyd House, *Brown*.—1 and 2, Dr. Horsfall, *Any other Variety*, 1, E. Lord, East Harwick, 2, G. Horsley, GESE.—1, E. Moore, Womersley, 2, J. Whittaker, Carlton, TURKEYS.—1, T. Plethorpe, Carlton, 2, Lady Hawke, GUINEA FOWLS.—1, D. Longstaff, 2, C. Marshall, Peckfield.

Judges.—Mr. S. Robson, Brotherton, and Mr. J. Wright, Snaith.

LIGURIANS IN JERSEY.

I SHOULD be glad to know if any of your readers have noticed two things in connection with their bees that I have observed—viz., the late appearance and scarcity of drones. In my stocks, four in number, no drones appeared till the middle of June, and then only very sparingly, and even at the present time they are not in great force. This time last year the massacre of drones was in progress; this year I see no signs of its commencement. A gentleman here who has a very fine strong stock of bees in a Woodbury hive, has seen no drones till within a day or two. The boney harvest has not been by any means good here up to the present time, as will be seen when I state what my colonies have done.

No. 1 is a pure Ligurian, with a queen at the head which I procured last autumn; it was then very strong and well provisioned. Though it had thrown off three swarms, it came through the winter well, which was a very destructive one to bees here; many lost nearly all their stocks. In the spring they gave signs of swarming, so the super was put on, but they have neither gone into it nor swarmed.

No. 2, hybridised Ligurians, located in a Neighbour's improved cottage hive. This contains a swarm of last year, which threw off a maiden swarm, was weak in the spring, but soon became very strong. The bells were put on, and the bees took possession, but did no work. Finding that the bells did not give them room enough, and that they were still likely to swarm, I put an adapting board on and a Woodbury super, taking care to wrap it up with non-conducting material; the bees began to work almost at once. They have constructed plenty of comb, but seem unable to find much honey, the long drought having had the effect of making the number of flowers less than usual. At one time honey-gathering went on very fast, but has almost stopped lately.

No. 3, a maiden swarm of last year, locted in a Woodbury, came through the winter well ; at the head of this is my original Italian queen. They went into the super June 16th, and for some time worked fast ; they have filled up the bars with comb, but now seem unable to get honey to finish filling the cells ; they have only admittance to five bars. The hive is very full of bees, and the queen breeding fast.

No. 4 is a stock obtained by uniting two lots of driven bees together last autumn ; at their head is a fine hybrid Ligurian queen. These wintered in two nucleus boxes placed side by side, but they only filled one with comb in the autumn. They came through the winter well, and are now fairly strong, but have neither swarmed nor supered. This I attribute to their not making use of the second nucleus box till I shifted half the combs and bees into it at the beginning of June. Strange to say, they have built no drone comb, and there is not a drone to be seen in the hive. I hope still that I shall get my supers finished, and that when the heath comes into full flower there will be a change for the better.—D. D. B.

OUR LETTER BOX.

SWELLED HOCKS (J. H.).—There are two causes to which swelled hocks may be attributed. The first is weakness, and may be the result of overgrowth, or insufficient or improper food. The other is improper flooring. The treatment for the first is to feed well and judiciously, giving plenty of grit and green food ; above all, in such cases, we recommend the use of Sussex ground oats. The only outward application is iodine. The remedy for the other, if the flooring is wood, brick, stone, or asphalt, is to remove it and substitute earth. Not only is there always damp from each of the floors we have mentioned, but from the hard non-yielding surface the toes are kept constantly stretched out, and the legs for hours in a strained and unnatural position. The overgrowth cures itself every day.

POULTRY, &c., DYING (B. C.).—At first sight we should pronounce your case one of poison, and the reason why some died while others escaped would be easily found—all did not eat it. You do not, however, believe in the poison. We fancy the pepper has been administered too freely. We are not friendly to pepper. We have given peppercorns advantageously sometimes, but never pepper itself. If your fields are like ours, the birds would get little from them. They would more likely want cooling than heating things. Have you had any thunder showers ? They will sometimes cause all you complain of. Young Turkeys are very prone to disease very closely akin to, if not identical with the roup, and they are spiritless creatures, giving up directly they are attacked. Their eyes swell, they refuse food, and die. Fowls and Partridges would catch it. Guinea fowls seldom do. It is always a bad plan to keep Turkeys and fowls together if it can be avoided. We believe it to be a case of poison from your description. If it is not, it must be either from sudden and violent rainfall or from roup. We advise you, if you can, another time to keep the Turkeys and fowls apart. Give the former on top chopped fine and mixed with their food. Avoid pepper for them all. When falling give them beer to drink, and let them have camphor in their water. There is nothing better for Turkeys and Pea fowls, if they appear drooping, than to give them two or three pills of camphor, each the size of a garden pea.

KEEPING GEESSE (S. Y.).—For breeding, not more than three Geese to one gander must be kept, and their breeding powers continue undiminished until more than twenty years old. They require a wide range, affording plenty of grass and still water. The goose-house for the four should not be less than 8 feet long by 6 feet wide, and high enough for a man to stand in upright. A smooth floor of brick and good ventilation are necessary. Over the floor a little clean straw should be spread every second day, after removing that previously used, and washing down the floor. A compartment about 2½ feet square should be assigned to each Goose for laying and sitting, and when one is hatching the gander and other Geese must be shut out from here. Whenever a Goose lays her first egg she is very pertinacious in her depositing the remainder. The Toulouse Goose is a very good layer, but rarely requires to sit, and, if she does, is a very bad mother. Where laying Geese are kept together, and they are liable to interrupt each other, remove the eggs daily, and mark on each the day it was laid. They will continue good for three weeks ; but the freshest eggs should be set upon. If the Geese keep well to their separate nests let the eggs remain. March and early April is the best period for goslings to be hatched in.

BLACK SPECKS ON AYLESBURY DUCK'S BILL (Aylesbury Duck).—We doubt whether you will by any means get rid of the black specks. They are very common, and by no means a sign of impurity or degeneracy of breed. They can be rubbed out with pumice-stone, but they often bleed, and the remedy is worse than the disease. There is a sort of sand or grit in Buckinghamshire, which is said to exercise a beneficial influence on the bills of the Ducks. We do not believe anything will remove the black spots. Your feeding is very good, and the birds will yet increase in weight. You are fixing a great task when you seek to attain 18 lbs. the pair.

HATCHING ARTIFICIALLY (A Recent Subscriber).—Whatever the source of heat, the temperature needed is the same, and in answer to your query we cannot do better than give the following extract from our "Poultry-Keeper's Manual."—"Anything will make a hatching-machine in which the temperature can be kept regularly at 104 or 105°. The commonest kitchen oven partly filled with dry sand, and kept at that temperature, will unfailingly hatch eggs. It can be done with greater certainty where gas can be made use of. Hatching is too often to the amateur what marriage is said to be to a man—then his troubles begin. He cannot make a mother. An incubator is useful in hot weather as a means of

providing every hen with a large brood of chickens, but the artificial mother is not equal to a good motherly hen."

CANKER IN YOUNG PIGEONS, &c. (A Constant Subscriber).—Apply a strong solution of alum to the mouths and throats of the birds twice a day with a feather. It may arise from had constitution, or the parents eating dirt with their food, or drinking bad water. Sand on the floor frequently changed would tend to diminish, and not encourage, vermin.

DRIED ASH LEAVES AS PROVENDER FOR COWS IN WINTER (S.).—We have made inquiry amongst our country correspondents as to gathering and drying the leaves of the ash for winter use, but we cannot learn that the practice has ever been adopted in England. The ash plants from which the leaves are taken must be injured in consequence, and, therefore, we cannot recommend the practice except where an ash coppice is to be destroyed. It is perfectly right to endeavour to increase the amount of fodder for the ensuing winter, and we intend, amongst other things, to give our cows a quantity of cut straw mixed with other materials from the miller, and to steam the whole, avoiding as far as possible everything likely to give the milk a taste.

METEOROLOGICAL OBSERVATIONS
In the Suburbs of London for the week ending July 26th.

DATE.	BAROMETER.		THERMOMETER.				Wind.	Rain.
	Max.	Min.	Air.		Earth.			
			Max.	Min.	1 ft.	2 ft.		
Wed... 20	31.159	30.699	89	51	72	63	W.	.00
Thurs... 21	30.003	30.043	90	50	72	63	W.	.00
Fri... 22	30.109	30.079	91	57	72	64	N.E.	.00
Sat... 23	30.061	29.957	82	59	73	64	E.	.00
Sun... 24	29.946	29.792	81	61	70	64	S.E.	.00
Mon... 25	29.789	29.735	87	55	69	64	S.E.	.02
Tues... 26	29.859	29.846	81	58	66	64	S.	.26
Mean...	30.002	29.954	86.20	55.71	70.57	63.71	..	0.28

- 30.—Fine; exceedingly fine; clear and fine at night.
- 21.—Very fine; nice and very hot; clear and fine.
- 22.—Exceedingly fine; very fine; fine, starlight.
- 23.—Very fine; exceedingly fine; fine and clear.
- 24.—Cloudy but fine; very fine; clear and fine.
- 25.—Fine but overcast; very fine; clear and fine.
- 26.—Thunderstorm; overcast; very damp; fine.

COVENT GARDEN MARKET.—JULY 27.

VERY little variation is to be noticed here, for although there is a large influx of soft fruit, the market is well attended by buyers to clear it away. The demand for hothouse produce, however, has much fallen off, the London season being over. In the Potato market we find a difficulty in meeting with good rounds, but kidney sorts are abundant and good.

FRUIT.

	s.	d.	s.	d.		s.	d.	s.	d.
Apples.....	4	1	6	2	Mulberries.....	quart	0	0	0
Apricots.....	doz.	2	0	4	Nectarines.....	doz.	6	0	12
Cherries.....	lb.	0	6	1	Oranges.....	per 100	7	0	14
Chestnuts.....	bushel	0	0	0	Peaches.....	doz.	5	0	15
Currants.....	½ sieve	2	0	4	Pears, kitchen.....	doz.	0	0	0
Black.....	do.	8	0	5	dessert.....	doz.	2	0	9
Figs.....	doz.	3	0	6	Pine Apples.....	lb.	2	6	5
Filberts.....	lb.	0	0	0	Plums.....	½ sieve	0	0	0
Gobs.....	lb.	0	9	1	Quinces.....	doz.	0	0	0
Gobberries.....	quart	4	0	6	Raspberries.....	lb.	0	0	6
Grapes, Hothouse.....	lb.	2	0	6	Strawberries.....	lb.	0	6	1
Lemons.....	per 100	8	0	14	Walnuts.....	bushel	10	0	16
Melons.....	each	3	0	5	do.....	per 100	1	0	2

VEGETABLES.

	s.	d.	s.	d.		s.	d.	s.	d.
Artichokea.....	doz.	3	0	6	Leeks.....	bunch	0	4	0
Asparagus.....	per 100	3	0	8	Lettuce.....	doz.	1	0	1
Beans, Kidney.....	½ sieve	4	0	6	Mockrooms.....	pottle	3	0	4
Broad.....	bushel	3	0	4	Mustard & Cress.....	punnet	0	2	0
Beet, Red.....	doz.	2	0	8	Onions.....	bushel	4	0	8
Broccoli.....	bundle	0	0	0	pickling.....	quart	4	0	8
Brussels Sprouts.....	½ sieve	0	0	0	Parley.....	sieve	8	0	0
Cabbage.....	doz.	1	0	2	Parsnips.....	doz.	0	9	1
Capiscium.....	per 100	0	0	0	Peas.....	quart	1	0	1
Carrots.....	bunch	0	4	0	Potatoes.....	bushel	4	0	6
Carthflower.....	doz.	2	0	6	Kidney.....	do.	6	0	8
Celery.....	bundle	1	6	2	Radihes.....	doz. bunches	1	0	0
Celeryworts.....	doz. bunches	9	0	0	Rhubarb.....	bunches	0	0	0
Cucumbers.....	each	0	1	6	Savoy.....	doz.	0	0	0
pickling.....	doz.	2	0	4	Sea-kale.....	basket	0	0	0
Endive.....	doz.	2	0	0	Shallots.....	lb.	0	6	8
Fenel.....	bunch	0	3	0	Spinach.....	bushel	8	0	0
Garlic.....	lb.	0	8	0	Tomatoes.....	doz.	1	0	3
Herbs.....	bunch	0	6	0	Turnips.....	bunch	0	6	1
Horseradish.....	bundle	3	0	5	Vegetable Marrows.....	doz.	4	0	0

POULTRY MARKET.—JULY 27.

PRICES gradually diminish, and will do so for a short time. We are led by the change that is coming over the trade to think of Grouse ; and then we shall drift on to Michaelmas.

	s.	d.	s.	d.		s.	d.	s.	d.
Large Fowls.....	3	6	4	0	Guinea Fowls.....	0	0	0	0
Smaller ditto.....	3	0	3	6	Pigeons.....	0	8	0	9
Chickena.....	2	0	2	6	Rabbits.....	1	4	1	6
Ducks.....	2	0	2	6	Wild ditto.....	0	8	0	9
Geese.....	5	6	0	0	Hares.....	0	0	0	0
Turkeys.....	0	0	0	0	Partridgea.....	0	0	0	0

WEEKLY CALENDAR.

Day of Month		Day of Week.		AUGUST 4—10, 1870.			Average Tempera- ture near London.			Rain in last 3 years.		Sun Rises.		Sun Sets.		Moon Rises.		Moon Sets.		Moon's Age.		Clock before Sun.		Day of Year.	
				Day.	Night.	Mean.	Days.	m.	h.	m.	h.	m.	h.	m.	h.	m.	h.	Days.	m.	h.	m.	h.			
4	TH	Stafford Horticultural Show.			75.9	50.6	62.8	17	30	af 4	41	af 7													216
5	F	East Neuk of Fife Horticultural Show.			74.5	50.9	62.7	19	31	4	40	7	24	2	40	11	8								217
6	S	DUKE OF EDINBURGH BORN, 1844.			73.2	50.8	62.0	21	33	4	38	7	40	3	morn.										218
7	SUN	8 SUNDAY AFTER TRINITY.			74.6	50.9	62.7	16	35	4	36	7	33	4	18	0	10								219
8	M	Length of day 14h. 58m.			74.5	49.4	61.9	18	36	4	34	7	50	5	4	1	11								220
9	TU				74.9	49.6	62.2	16	38	4	32	7	47	6	1	2	12								221
10	W	Anniversary Meeting of Royal Botanic Society.			75.1	51.3	63.5	19	40	4	31	7	27	7	6	3	13								222

From observations taken near London during the last forty-three years, the average day temperature of the week is 74.6°, and its night temperature 50.6°. The greatest heat was 93°, on the 10th, 1842; and the lowest cold 35°, on the 4th, 1865. The greatest fall of rain was 1.08 inch.

PEA CULTURE.



It is generally recognised as the importance of obtaining a supply of Peas as early in the season as possible, that any mode of cultivation tending to do away with the feeling of uncertainty respecting the success of the first sowings is worthy of attention. I will therefore describe, long before such sowings should be made, a method by which I have been very successful.

A mode of culture now somewhat obsolete, but which, notwithstanding its speculative character, has still its advocates, was to make the first sowing in November, some sowing on a warm sheltered border, while others having greater resources sowed a double quantity—half on the south side of a wall and half in a more exposed situation. In mild winters the sowing on the warm sheltered border would grow so fast, and become so tender, that the first sharp frost would be sure to destroy it. A row or two in the open ground, across one of the garden squares, had a much greater chance of success. This success, however, was never certain; even if the Peas escaped the ravages of the mice and the tender attentions of the sparrows—to say nothing of the operations of snails, which, concealed from view, made their Christmas dinner off the abundance of rich succulent matter with which the gardener had so abundantly stored their winter quarters—the chilly blasts of lingering winter or tardy spring frequently destroyed the young plants.

The way in which I have avoided all this uncertainty and loss has been by sowing in boxes made in the following manner:—Some half-inch deal boards, 9 inches wide, were sawn in halves, and cut into lengths of 3 feet for the sides, and smaller lengths of 5 inches for the ends; these were nailed together, and thus a number of narrow frames were formed, each measuring 4 inches wide, 4½ inches deep, and 3 feet long. Pieces of board were next cut of a suitable size to form a bottom to each frame. The loose bottom boards were ranged side by side on a warm sheltered border, and the frames placed on them, and filled with rich soil, in which the Peas were sown in the second week in January. I may say I was pleased with the plan so far, but then came the thought, "How about the mice and sparrows?" True, I could defy the sparrows by placing some netting over the boxes; but then netting is no protection against mice, and I began to fear for the result, when I suddenly remembered that I had nearly 100 feet of glass on hand, in squares 9½ by 7½ inches, just a handy size for the purpose. Nothing could be better; the entire surface of the soil in the boxes was at once covered with the sheet glass, which not only protected the Peas, but the soil was warmed by the sun heat it transmitted, and the seed vegetated very quickly. The glass was allowed to remain till it was fairly lifted up by the young growth, when it was removed, and laid flat on the soil over another crop which had, meanwhile, been sown in the open garden. As crop followed crop, the glass was kept constantly in use with the best possible results. The

mice were decidedly puzzled, traces of them were visible at places along the edges of the glass where they had tried to burrow underneath, but the labour was evidently too great for one night's work, and before the next night the holes were filled up and traps set. Should any of your readers adopt this means of protection (and I would strongly recommend it to all whose crops suffer from the depredations of sparrows and mice), they will find the size of squares I have mentioned the best for laying lengthwise over rows of Peas.

When the drills are drawn, if the soil is found to be at all dry, it is necessary to give a thorough watering after the Peas are sown before laying on the glass. If the glass is used for the summer sowings it must be removed immediately after the young growth becomes visible, as the sun is then so powerful that it will burn the tops of the young plants if they be suffered to come in contact with the glass.

To return to the first crop in the boxes. When the glass was taken off, as the plants were somewhat tender and, consequently, likely to suffer from frost, stumps were driven in the ground on each side of the boxes, and some slight poles laid across and nailed to the tops of the stumps, thus forming a light framework a few inches above the Peas, on which a couple of thatched hurdles were placed nightly and during snowy weather. As an instance of the utility of the thatched hurdles, I may mention a fall of snow 2 inches deep on the night of March 12th; the morning of the 13th being clear and bright, the hurdles with their load of snow were lifted off, and so the Peas enjoyed the genial sunshine while other things were buried under the snow.

The spring of this year was so cold and changeable that the Peas were not turned out of the boxes till April 1st, when a narrow trench was made to which they were taken one by one, the loose bottoms removed, and the sides, after a slight shake, lifted up, leaving the Peas in the trench, where the lengths were fitted against each other, forming one long row. The soil was a mass of roots, so that the wooden sides were drawn off without any mishap.

After the Peas were planted out the frames were again placed on their moveable bottoms, filled with soil in which some dwarf Kidney Beans were sown, and set under the stage of a vinery at work. In six days the cotyledons were to be seen forcing their way through the soil, and the young plants were at once taken out of the vinery, and the boxes once more occupied their original position. The Beans were protected for awhile at night by the hurdles, and at length turned out in a warm border. Thus two early crops were obtained by means of these useful boxes.

In concluding this paper, a few remarks on Pea-culture generally may not be out of place. One of the chief points is the maintenance of a constant supply of young Peas throughout the season, and as an important means to this end, well-tried sorts only should be selected. If novelties are cared for (and they should certainly have a trial), a small quantity may be sown, but they should form no link in the regular cropping. Dwarf-growing kinds are

as a rule, best suited for small gardens, but in large gardens the tall kinds are best.

In making a selection of the best sorts, to be sown in the order in which they are named, I would choose Ringleader, Climax, Laxton's Prolific, Champion of England, King of the Marrows, British Queen, Veitch's Perfection, and Ringleader again for a very late sowing. As to the time of sowing, monthly sowings should be made in January, February, and March, and fortnightly sowings in April, May, and June; after which time two or three successive sowings of Veitch's Perfection and Ringleader are useful to prolong the season should it prove favourable.

Peas flourish best in a deep rich soil, in which the roots penetrate to a great depth, and, therefore, wherever the soil is poor or very light, and manure scarce, the latter should be put in trenches as for Celery plants, and the Peas sown in the soil covering it. A thin dressing of manure spread over the surface of the soil and forked in, will be of very little service to the Peas. As I have found it necessary to use trenches for Peas in the garden here, the plan followed is, when arranging the ground for cropping in spring, to leave spaces about 20 feet apart across the garden squares, each space to be occupied by a single row of Peas. The trenches are opened, the dung wheeled in, and the whole of the spaces fully prepared before spring comes on, so that nothing is left to be done when the Peas are sown but to draw the drills in the usual way. I have now a large breadth of Potatoes intersected in this manner with rows of Peas, and as the crops are all flourishing and the Pea rows at a uniform distance from each other, the whole has a very neat appearance.—EDWARD LUCEHURST, *Egerton House Gardens, Kent.*

A PLEA FOR DOUBLE-FLOWERED PELARGONIUMS AS BEDDERS.

"THEY will never do as bedders," is the remark one constantly hears concerning these brilliant novelties. "They are so scant in their flowering, and they are so thick in the truss, that they will be matted together like the Hollyhock in wet weather." And so I thought too, but a little longer experience has caused me to alter my opinion, and I am now inclined to think that in a little time they will become very great favourites. We shall have to discard the originator of the new strain Gloire de Nancy, and any others that partake of its very gross habit; but we are gradually obtaining varieties of a dwarfer habit, and it is to these I look. I have a long border running down my small lawn, and have planted in it various kinds of Pelargoniums, dividing the sorts with a band of Perilla. We had heavy rain on two days, but on looking down the border on the evening of the second day, my eye rested at once on the greenest and most brilliant-looking spot in it—where some of the doubles were planted; the rain had not injured them, and their large, massive trusses shone out above the green foliage. When I say that I had in this border Excellent, Lord Derby, Editor, Sir Fitzroy Kelly, Chieftain, and Miss Martin, I think this is saying something for it; and when we can multiply such kinds as Wilhelm Pfitzer and Marie Lemoine, they will form striking objects, while in a dry season, such as we had last year, they are admirable. There are no seed pods, and the bed is therefore not disfigured by them, so that as the propagating season has now begun I would suggest a trial being made, and I do not fancy those who may make it will be disappointed.—D., *Deal.*

BERBERIS DARWINII.

Or the hardy berry-bearing shrubs that are commonly grown for pleasure-ground ornamentation, there is none that I have seen to equal *Berberis Darwinii*. It is suitable for very nearly any position, it will stand wind and wet well, is perfectly hardy, and is very attractive at all times. Since its ornamental qualities have become better known I see it is being used in park planting; a group of from seven to twenty or more plants will in a comparatively short space of time form an almost impenetrable thicket of wood and foliage, the branches growing close to the ground. Its orange-coloured flowers are produced in great profusion, and it is then a conspicuous and ornamental object when viewed from a distance; and afterwards its slate-coloured berries, which are as numerous as its flowers, make the plant not less attractive to the passer-by.

In my opinion one of the most suitable positions that can be assigned to such a desirable shrub is by the side of a car-

riage drive, whether planted singly or in groups of three plants here and there, and associated with taller-growing plants. Where circumstances are favourable to such an arrangement, I think it will not fail to please. Of course in such positions a good-sized bushy plant rather than a very tall one will be the best to grow, but as its habit is favourable, and its growth vigorous, these proportions will soon be reached. A little guiding, however, will be necessary, by giving an annual pruning of all gross shoots, which the plant is apt to throw up after it has become established. This pruning will favour the production of flowers and, consequently, fruit, because it is on the medium-sized wood that these are most abundantly formed.

This beautiful *Berberis* is often to be seen growing at the front of shrubbery borders, or round the margin of shrubbery beds. These I consider are very suitable and proper places for such a useful plant. The plants are here growing in such positions in great numbers, and nothing could better suit the purpose for which they were planted. I do not advise planting them as some do in the background of a shrubbery bed or border, among coarser-growing subjects; they are there seldom fit to be seen, and are in time quite overgrown by their more vigorous associates.

To keep the plants in good health, the surface soil around them should never be dug, but only stirred, as the roots are very near the surface. There are few places where this *Berberis* thrives better than it does here, in a very heavy loamy soil approaching a clay. Although it will thrive tolerably well in a light soil, I consider a heavy one the most suitable; the foliage is then darker, and the colour of the flowers a beautiful orange yellow.—THOMAS RECORD, *Lillesden.*

NEW AMERICAN POTATOES.

In April last I planted 1 lb. each of Bresee's King of the Earlies (four Potatoes, sixteen sets), and Climax (three Potatoes, twenty-three sets), and have taken up the produce to-day (July 25th), with the following results—King of the Earlies, 18½ lbs., largest Potato, 5½ ozs., many about that size; Climax, 39½ lbs., largest 14 ozs., no other near that size.—W. J. S., *Devon.*

PRUNING ORNAMENTAL TREES AND SHRUBS.

No. 5.

Portugal Laurel.—Under most conditions this is a handsome shrub, but is never so fine as when subjected to judicious, timely pruning. It requires plenty of room, light, and air, though, with pruning at an early stage of growth, and continued annually or biennially, it may be kept in comparatively small space. In shrubberies, however, the plants ought not to be very closely pruned, but I consider it necessary to go over them every spring and well cut back any irregularities; indeed, whenever there is very free growth the shoots, from being long, are apt to start from the points only, and the tree becomes open and bare of foliage unless the long annual shoots are pruned in well every spring. If height be wanted, the pruning may be confined to the sides of the tree, but I would, nevertheless, shorten the shoots near the top, as stronger, more regular growths are produced from the ripe than the sappy points of the shoots. Should the trees have become too large, they may be cut back to the size required, and in a year or two they will exhibit a close leafy growth. When of the desired size the pruning should be performed every year in April, cutting off most of the preceding year's growth, which will be replaced by that of the current year. Of course, where there is room, all the pruning required is confined to cutting off any growths likely to interfere with the symmetry of the tree.

Standard Portugal Laurels have so close a resemblance to the Orange and Sweet Bay, that unless closely examined by a practised eye they are hardly distinguishable; but it is seldom we see Orange trees so leafy and healthy as to be presentable as summer ornaments in English gardens. Portugal Laurels, on the contrary, are quite hardy, and succeed both in summer and winter in all but very bleak situations, being, in point of hardiness, vastly superior to the Sweet Bay, which only succeeds in warm situations; hence the necessity of growing the latter in tubs for removal in winter to a place of shelter.

Portugal Laurels grown as standards may have stems of any height, but I consider 3 or 4 feet sufficient. The plants intended for standards should be trained with one straight clear stem, and those raised from seed are to be preferred. To give

stability to the stem it is well not to cut away the side shoots, nor shorten them very closely until the required length of stem is obtained, as well as a head large enough to shield it from the sun, or say of 2 feet in diameter. The leader must, of course, be stopped when it attains the height desired, and the shoots that result from the stopping should have their points taken out when they have grown 6 inches, and I would again stop them when that length of fresh shoot is made; for, though we may obtain a larger spread of head in the first two or three years by allowing the shoots to grow at will, or with but little shortening the first few seasons, the head will be for the most part bare of foliage near the stem, and to clothe them there we have to begin over again. On the other hand, by attending to the stopping of the shoots in the first instance, we secure a close leafy growth from the first, and maintain it by a system of close pruning. Thus, though the annual progress may appear small, the trees from the first are compact.

The first shoots should be brought down at the end of summer to a horizontal position, and be secured with matting to the stem. Unless this be done they have a tendency directly upwards, and once they are allowed to take this direction it is difficult to get the side shoots sufficiently low to hide the setting-on of the head; but when the shoots have an outward tendency it is easy to maintain that character of growth. When the head has grown to the size already stated, the shoots on the stem should be gradually removed, and finally cut off close to the stem, and by a clean cut with a knife; though allowed to remain for a time, they must always be kept secondary to the head by close stopping. Another point to be attended to is keeping the head flat or table-like for a few seasons; therefore, the shoots produced on the top of the head must be more closely stopped than those at the sides, so as to cause more vigorous growth outwards or at the sides. When the desired breadth of base is secured the centre can soon be filled up, as the growth is always more free in that part than in the horizontal side branches. Nevertheless, we must not allow the centre to fill up too quickly, but by frequently stopping and shortening the shoots we must endeavour to secure a close growth, which is very important in geometrical and architectural gardens.

The form of head is a matter of taste. Half spheres are pretty, and pyramidal heads are effective, whilst columns but little wider at the base than at the top are equally desirable. I may be thought restricted in my views, but I cannot forbear expressing my admiration of a fine line of Portugal Laurels on stems of equal height, and with symmetrical, even-sized heads, on a wide terrace of velvety lawn, green to their trunks, and with a wide walk running between them—a line being on each side of the walk. When desirable the plants may be in tubs, but they do not grow so well in this way as when planted out, and it is necessary to protect the tubs with straw in very severe weather, otherwise the roots will be injured, and in the case of standards the stems require to be wrapped round with hay-bands to preserve them from severe frosts. In bleak exposed situations they should be removed to a sheltered position in winter.

The *Sweet Bay* is one of the best of all trees for forming pyramids, and even standards, but except in warm situations it does not succeed in tubs in our climate, requiring protection in winter. Standards, as a rule, are not generally successful; pyramids are much to be preferred. They are formed in much the same way as pyramidal Hollies, and the same remarks apply to pyramidal Portugal Laurels: therefore it will be needless to give further instructions for their formation, and I shall dismiss them by stating that in winter Sweet Bays should have a warm sheltered position, the tubs being well mulched round with dry litter, and in case of very severe weather they would be the better of a cool house.

Laurustinus is another of those subjects which form handsome pyramids and dwarf standards, and these, in their formation, require the same treatment as Hollies. The best time to prune them is immediately the flowering is past, and then they may be cut in little or much as required. When grown in tubs they require to have a sheltered position, and in severe weather protection like the Portugal Laurel and Sweet Bay; indeed, they are well worthy of glass protection, and are much in demand on the Continent both for out-door and in-door decoration. The *Laurustinus* is well suited for the decoration of corridors, halls, and cool conservatories during the winter months. They are fine whether grown in pots or tubs.

Box is not much in repute, except for general purposes in shrubberies, though for forming small cones, and for bushes of

any form, there are few trees to equal it. Box trees thus trained have the disadvantage of becoming loose and open, and that, too, when of considerable size; but this might have been remedied by commencing the pruning in the early stages of the plant's growth, and continuing it annually, so that the growth becomes stiff and branched instead of long and but little forked. The main point to be attended to is to well furnish the plants at the base; to secure their being so cut-in the upper part more than the lower, and thin out the shoots in the thick parts, so as to encourage the growth of the thin. If that be attended to once a-year, or even every two years, the trees will be very regular and close. If the lower parts are very weak and thin, it is advisable to leave them almost entire, only cutting off the long straggling parts; but the upper portion of the plant should be cut-in closely a fortnight or three weeks after the lower part is pruned.

The best time to prune is in May or early in June in moist weather. At that time the trees may be cut-in to any extent, and will soon push again, and be quite green before winter. Any irregularities of growth may be removed in August or early in September. The pruning, of course, must be such as to allow a progressive growth; but when the trees are of the size required they should annually be cut-in closely, or, if the growth is weak, every alternate year will be sufficient. Those which are of weak growth ought to be pruned earlier than those which are strong, as by pruning the latter after they have made some growth they do not get so strong as when pruned while at rest. Pruning when a tree or shrub is at rest, is favourable to an increased vigour, but pruning a growing tree has a contrary effect.

The best kind of Box for pyramids, bushes, and trees, is the Tree Box, which in some soils and situations attains a considerable size, and is a handsome tree. The best variety of it for pyramids is *pyramidalis*; and *B. balearica*, the Minorca Box, is good. The silver-variegated and the gold-variegated form fine bushes and pyramids for the winter decoration of the flower garden; in summer, even, they have not a bad effect as neutrals, as centres to large beds or detached.

Box makes an excellent low screen, being better for the purpose than either Yew or Holly, being more easily kept in form.

Common Laurel.—I can say but little of its merits for training as a cone or pyramid, but those who wish it in these forms may pursue the treatment recommended for the Portugal Laurel.—G. ABBEY.

"REDCARRE, A POOR FYSHER TOWNE."

THAT is the description in one of the Cotton MSS. in the British Museum, of the place whence I am now writing, and the MS. proceeds saying, "The sea shells and sand serve instead of marle to enrich the land, which is fruitfull of itself, but much bettered by the neighbourhood of the sea, makinge the good husbendes of the lowe grounds fatt in the purse, and merry in the hearte." The said sea-sands, however, and they are vast, do not so benefit and make merry the denizens in Redcar. I have read of sand storms and sand-buried cities in the East; I have been dredged thoroughly with the red sand of the Cape of Good Hope; I have been near the exhumed Cornish church, Peranzabuloe, but never until I rested at Redcar could I realise the silent conquests by the sand. Whilst I write a half-gale from the north-east is blowing, no clouds of sand are raised, but it flows in ripples along the ground and rapidly accumulates in heaps against any opposing object, and soon forms a hillock. The scavengers are now carting away loads that accumulated in one mound before the window where I am now sitting. A former visitor was similarly surprised at this rapid sand-accumulation, and not seeing any mode of rescue, on asking a man how he extricated his cottage from the sand, he felt rather humiliated by the reply—"Why, I shovels it away."

"The husbendes of the lowe grounds"—the Cleveland Vale—will this year be "fatt in the purse and merry in the hearte," if the weather of harvest-time be propitious, for never did I look upon heavier unladen crops of Wheat and Oats, better-podded Beans and Peas, or more perfect plants of Swedish Turnips. I remember the time when a field of Swedes was very rare, but now white Turnips are the rarity. Winter keep, therefore, will not fail the noble Teeswater, or Holderness kine which prevail along this valley. "The sea-shells and sand," I am pleased to see, are not the only enrichers now from the sea used by the Cleveland "husbaudes," for I see pastures recently and judiciously sprinkled over with sea-weeds. I say "judiciously,"

because they are so thinly scattered as to shade and shelter but not to blanch the grass. Their saline and organic constituents gradually fertilise the soil.

Let it not be supposed from the quotation with which I have headed these notes, that I consider it still applicable. Those words might have been appropriate two centuries since, but they are used by me only as a striking contrast to a fair description of Redcar, as it is now a thriving, increasing town, supplied with all the requisites of a sea-bathing resort, and with unsurpassable sands for exercise. On foot, on horseback, or in a carriage, those firm stoneless sands, hundreds of yards wide, and more than seven miles in length, may be traversed. Many places of interest, too, are within easily-reached distance on foot, by railway, and by carriage, but at present I must confine my notes to one day's stroll.

That stroll was to Kirkleatham and a few miles beyond, little expecting to find hereabouts monuments—worthy monuments, of a Lord Mayor of London; yet in the church there rests Sir William Turner, chief magistrate of your city in 1669, one of its most wealthy merchants, and the frequent creditor of Charles II. He founded at Kirkleatham a noble hospital for aged men, aged women, and children; a museum, a library, and a free grammar school, but this last-named is now rebuilt at Redcar. I presume he was a native of Kirkleatham, and I was well pleased to rest beneath venerable trees whose shade he must have often enjoyed. Not many years since one of their companions was felled, and then rifled for firewood, in doing which the heart of the tree turned out entire, and on it, spirally written, were these two lines—

"This tree long witness bear,
Two true lovers did walk here."

The portion of the tree with its inscription is preserved in the Turner Museum I have mentioned. The inscription is perfectly legible, and is literally as follows—

"This tree long time witness beare
Of tow lovers that did walk here."

A poet has written on this theme, but I will only quote the first and last verses:—

"Long the wintry tempests braving,
Still this short inscription keep;
Still preserve this rude engraving,
On thy bark impured deep—
'This tree long time witness bear,
Two true lovers did walk here.'
On thy yielding bark engraving
Now, in short, our tender tale;
Long, time's roughest tempest braving,
Spread thy branches to the gale;
And for ages witness bear,
'Two true lovers did walk here.'"

Passing on I soon reached Wilton Castle, a residence of Sir Charles Lowther, Bart. The village is within the park's boundary, and if any one wishes to see model cottages, church, and graveyard, they are there. Never did I see such appropriate, uniform neatness. The cottages are examples of cleanliness and comfort, they make one feel how such dwellings must tend to promote a love of home and self-respect in their labourer tenants. To them with truth—would that I could say the same of all in England—may be applied the verse—

"The cottage homes of England! how cheerily they stand,
Abodes of comfort and content throughout the pleasant land."

The gardens of Wilton Castle are of very limited extent, which is fortunate for the gardener, Mr. Henry Reed, for as there is only one small greenhouse, he would be unable to winter the bedding out plants required for extensive flower borders. The great charm of the place, however, is in the extensive walks through the wood-clothed hills; these wide, well-kept walks are delightfully shady in summer, and, facing the south, are sheltered and enjoyable in the fine days of winter. There is a large picturesque waterfall, but the dry summer we have had prevented me seeing it in its full beauty. The Magnolia was in bloom, and the Figs ripening against the south front of the Castle, and an abundant crop of Noopark Apricots are on a wall having the same aspect in the kitchen garden—it deserves a note that they had no protection of any kind during either the winter or spring, though at this north-east corner of Yorkshire. The whole are well-ordered by Mr. Reed, and one of your Editors will say he is a man of judgment, for among his books I saw London's "Encyclopedia of Plants," Lindley's "Theory of Horticulture," and Johnson's "Cottage Gardeners' Dictionary."—G.

DENDROBIUM MACCARTILE.—This beautiful Orchid is just now in great beauty at Messrs. Veitch's, Royal Exotic Nursery,

Chelsea, where there is a plant with no less than one hundred expanded flowers.

THE EVERGREENS OF CALIFORNIA.

PERHAPS no country in the known world has been more liberally favoured with all that is grand and beautiful in vegetable life than has California. Whether we are particularly interested in the smallest plants with their gorgeous flowers, in ligneous shrubs clothed in attractive foliage, and emitting delightful fragrance, in deciduous trees with a semi-tropical aspect, or, lastly, evergreens of the most imposing and elegant forms—the Sierra Nevada range of the "Golden State" cannot be surpassed in richness.

I purpose to call attention exclusively to the various members of the order Conifera, and especially to those which I have studied in all the glory of their native haunts.

In the Pine family proper, I will commence with the *Pinus contorta*, Douglas (Twisted-branched Pine).—A medium-sized tree, rarely growing more than 50 feet in height, but forming one of the most beautiful and compact specimens I have ever seen. They are never found in the valleys, but always near the summits of the higher ranges, especially surrounding some level plateau, where the soil is damp and cool. In such situations it is of moderately rapid growth, very dense in structure, bright glossy green in colour, and regularly conical in outline. It is closely allied to the *P. inops* (Yellow Pine) of the Atlantic coast, although far superior to the latter as an ornamental tree.

Pinus Fremontiana, Endlicher (Fremont's Pine)—Is found at high elevations on the mountains, and is another of the smaller-sized trees, which will undoubtedly prove very attractive in our collections. The leaves of this species present a very curious feature, being almost entirely monophyllous—i. e., one leaf in a sheath on the younger shoots, and of a bright bluish green in colour. The branches, although not so numerous as in the preceding, are nevertheless sufficiently so to form a moderately-compact head, and when viewed in conjunction with the very attractive foliage, leave little to be desired. The cones are small, and of a greenish tinge on the surface; when open, displaying a few large edible seeds; these are in great request by the Indians, and are very nutritious and agreeable to the taste.

Pinus edulis, Engelmann (Edible-fruited Pine)—Closely resembles the foregoing, the distinctive feature being in the size and shape of the cone. Young plants of this species have proved quite hardy in the Eastern States, and I trust we shall thereby secure a valuable addition to our collection.

Pinus ponderosa, Douglas (Heavy-wooded Pine)—Is seen soon after commencing the ascent of the mountain range, and is one of the most numerous species until we approach the summit, when it ceases to be met with. In passing through the almost interminable forests that clothe these regions, we see many thousands of the Heavy-wooded Pine of all ages and sizes, from the handsome-shaped specimen of 8 or 10 feet in height, to the old scarred veteran towering up at least 150 feet. In the case of the latter, the rough, deeply-seamed bark presents a curious appearance. Indeed, the whole tree forcibly reminds one of a vigorous specimen of the Austrian Pine (*Pinus austriaca*), but much coarser in growth than the latter species. As a strictly ornamental tree, it will, therefore, never prove popular, but in our larger plantations, on rocky eminences, and for distant belts and masses, it will be available and useful. One of the largest specimens I have seen was growing in the beautiful valley of the Yo Semite, and measured 21½ feet in circumference 5 feet above the ground. I frequently met with trees from 15 to 18 feet in girth, and, in fact, the larger portion of them were at least 4 feet in diameter, with their huge bodies destitute of limbs for at least one-half their height.

Pinus Jeffreyi, Hort. (Jeffrey's Pine)—In size and appearance of tree presents all the characters pertaining to *P. ponderosa*. The cones, however, are very different, and herein alone exists the specific distinction. Occasionally I have noticed a chance specimen with more slender leaves, but this peculiarity is not constant. It is hardy, a rapid grower, and would make an admirable shelter.

Pinus Sabiniana, Douglas (Sabine's Pine)—Belongs entirely to the Foot Hills at the base of the mountains, and in consequence will prove of doubtful utility with us. Indeed, I do not know of an instance where it has proven successful; but, nevertheless it is remarkably elegant when young, presenting one of the most charming examples of the delicate graceful type of Conifers to be met with. The foliage is about 12 inches

in length, very slender, and of a peculiar light bluish green colour. All the young shoots are likewise tinted with a pretty glaucousness, thus adding to its charms. The older trees do not attain a large size, and differ from other species in the form of the head, which is always branched at the summit, and spreading after the manner of many deciduous trees.

Pinus Torreyana, Parry (Torrey's Pine)—Greatly resembles the foregoing in manner of growth and general appearance of foliage. If hardy, it would prove a decided acquisition here, but from its close affinity to the Sabine's Pine, and its still warmer locality, I very much doubt its utility with us in the Middle States.

Pinus insignis, Douglas (Oregon Pitch Pine, Seal Pine, &c.)—Is found along the coast near San Francisco, and is frequently seen in cultivation in the gardens of that city. When young the trees are remarkably dense and elegant in appearance, but the mature specimens present rather a ragged and open structure. The *Pinus radiata* of Don is not distinct from this species.

I now arrive at the grandest of all our Pines proper, *Pinus Lambertiana*, Douglas (Sugar Pine, Lambert's Gigantic Pine, &c.)—This species is even more sub-alpine in its choice of location than *P. ponderosa*, and, as a natural consequence, is entirely hardy with us. The sight of these great trees rising in the air to the height of 150 and 200 feet, with a clean shaft of 75 or 100 feet without a limb, presents a grand spectacle. I measured a large number of specimens, varying from 20 to 25½ feet in circumference, and it was no uncommon sight to see several of this size standing close together. The ground beneath was usually covered with huge cones, which were often at least 20 inches in length. The leaves are not unlike those of the *P. Strobus* (White Pine), excepting that they are more rigid, and of a darker green in colour.

Pinus monticola, Douglas (Short-leaved Weymouth Pine, Mountain Pine)—Also closely resembles our White Pine, but has a larger cone, and rather shorter leaf. It grows to a large size, and is entirely hardy in our climate. I only noticed it in localities where the preceding species was growing.

Leaving the Pines, we now pass to the next genus of importance—the Abies or Spruce family. Soon after commencing the ascent of the mountain ranges, we find specimens of *Abies Douglasii*, Lindley (Douglas's Spruce), and as we rise still higher, a large portion of the forests are composed of this tree. The younger specimens are really charming; not only on account of the rich glossy green colour of the foliage, but more particularly for the graceful drooping habit of the branches. As to their size, I measured many trees whose bodies were from 15 to 18½ feet in circumference.

Abies amabilis, Lindley (Lovely Silver Fir)—Is justly named, for the most indifferent observer of trees could not possibly pass through the great forests of this species which clothe the summits of the Sierra Nevada without experiencing a feeling akin to awe. So dense is the verdure and so numerous the trees, that the darkness on our path induces the belief that the dusk of evening is near at hand; and yet, as we emerge from these vast clumps into a cleared space, where the bright sunlight glances through the foliage, the effect changes, almost like a kaleidoscope, into the most brilliant tints of blue and green. Such is the aspect of the Lovely Silver Fir. In size I may say they form no exception to the neighbouring trees, for I saw very many that were from 20 to 23½ feet in circumference, and with a naked body of 100 feet in height, the foliage branching out in a dense mass at the summit.

Abies grandis, Lindley (Great Silver Fir)—I found in the same localities as the preceding, and about equal in size and number. Well does it merit its name; and had I even the time to give you a perfect description of its surpassing beauty and grandeur, I could not do it simple justice. It differs from *A. amabilis* in having the leaves arranged strictly in two rows, long, and slightly incurved at the extremities. The colour is pale green, but the great height of the old trees—200 feet and upwards—leads one to believe that the foliage is exceedingly dark. The odd-looking cones stand erect on the summit, and are rarely seen on the younger plants.

The only Juniper I noticed in California was the really beautiful *Juniperus occidentalis*, Hooker (Rocky Mountain Juniper). A specimen is found on one of the highest peaks near the Yo Semite Valley, where the bleak winds and cold storms for many years have not marred its symmetry. The silvery foliage, thickly interspersed with purplish-brown berries, presents an agreeable picture to the lover of trees. I am happy to say it succeeds well in our Eastern collections.

One of the largest trees to be found in California, excepting only the Sequoia, is undoubtedly the *Libocedrus decurrens*, Torrey (incorrectly White Cedar, in its native locality). Many of you will doubtless recognise it as the *Thuja gigantea* of foreign nurseries and authors, and as such introduced into our collections from abroad. I found vast numbers of it on the steep mountain sides at high elevations, and especially in the vicinity of the Yo Semite Valley. The trees, when young, are very handsome, forcibly reminding one of a fine specimen of Arbor-Vitæ, but much more glossy, and lighter in colour. The finest specimen I saw was 25½ feet in circumference, and over 200 feet in height.

Taxus brevifolia, Nuttall (Short-leaved Yew)—Forms but a small shrub in California, although further north it assumes the proportions of a tree. In foliage, it approaches more nearly the handsome *T. adpressa*, of Japan, than any other species. The brilliant scarlet fruit, scattered thickly over the plant, contrasts charmingly with the dark glossy-green of the leaves.

Torreya californica, Torrey (Californian Nutmeg Tree)—Is quite rare; but I was fortunate in finding a very fine specimen on the cliffs at the foot of the Yo Semite. It is Yew-like in character, forming a medium-sized tree, with long, dark-green glossy leaves, very sharp-pointed. The fruit, as its name suggests, is not unlike a nutmeg in appearance, but totally unfit for use. I am afraid it will not prove hardy here; but should it do so, we may anticipate much pleasure in its introduction.

I close my descriptions with the most majestic of all our native trees, the *Sequoia gigantea*, Torrey (Great Tree of California), and popularly called "Washington" and "Wellingtonia." During my journey over the Sierra Nevada Mountains, I had the pleasure of visiting the extensive group known as the Mariposa Grove, embracing the largest trees to be found. I shall not soon forget my feelings, when, after having ridden all day through forests of great Pines and Firs, I emerged suddenly into a little valley, and found myself surrounded by these wonderful trees. The abrupt change in character was so new, and almost incomprehensible, that I lingered among these strange forms until the quickly passing hours warned me I should once more be obliged to resume my journey towards civilisation. The casual observer cannot at first comprehend their immensity; but standing close by their sides, and looking steadily up into their great shaggy tops, the vastness and sublimity of their proportions almost imperceptibly steal upon the senses.—JOSIAH HOOPER, *Westchester, Pennsylvania*.—(*American Gardener's Monthly*)

MYATT'S FILBERT PINE STRAWBERRY.

I DOUBT whether Mr. Creed (page 58) has the true variety. Mine, which came from Mr. Turner, instead of coming into bearing with Black Prince, are decidedly late, as pointed out in Dr. Hogg's "Fruit Manual," and runners, so far from being plentiful, are late and scarce. Indeed, it is probably from this latter circumstance that so high-flavoured a variety is seldom seen in cultivation.—G. S.

LAWN MOWERS.

I THINK all who have worked the Archimedean lawn mower will agree with me that "VITIS," in writing about it (see page 25), rests too much on its inferiority to Green's machine. I cannot speak ill of the latter, nor do I give the Archimedean the preference, but who can say a 14-inch Archimedean is hard work for two strong men? I have one of that size here, and can testify as to the small amount of exertion required to use it; and more, I can confidently and truthfully say that there is no other machine to approach it for ease in working. As to its cutting long grass, it does it well, and with comparatively little labour, although it is a quality not much needed, as a lawn, to look well, ought never to be allowed to grow more than a week without mowing. With regard to the machine clogging quickly, I have never found it do so, not even when the grass was very wet. What machine has cutters capable of withstanding, without being notched, contact with stones? As to a small stick, I think it would have but little effect. If the blades of the machine "VITIS" has are notched and look like a saw, his lawn must be extremely stony. I never sweep after mowing, nor is it necessary, as not a trace of cut grass is to be seen after a few hours.

I agree with "VITIS" as to the Archimedean not cutting close to a flower bed, and the shorter the curve the greater the

objection, owing to the skids protruding so far that in going round they thrust into the bed and injure the plants, but verger I can and do cut with it. Another objection is that it does not cut quite so closely as I should wish; but this objection will, perhaps, be all in the machine's favour, as in a more growing season than the present the cut grass will be more readily lost to view than if it were shaven off close to the ground, which would tend to give a rusty appearance.

I do not pretend to say that the Archimedean is the height of perfection, far from it; there is room for improvement, but it is a great advance in the way of diminishing labour. We must also bear in mind that since Green's and other machines came into use great improvements have been made in them, and I have not the slightest doubt but that our American cousins will eventually make as great an improvement on the Archimedean.—E. Morgan, *The Butts, Harrow-on-the-Hill.*

HORTICULTURAL CONGRESS AT OXFORD.

(Continued from page 65)

THE next paper read, was that of Mr. William Paul, of Waltham Cross, viz.:—

ON COLOUR IN THE TREE SCENERY OF OUR GARDENS, PARKS, AND LANDSCAPES.

LAST year I had the privilege of reading a paper at the Manchester Congress of this Society, "On the Improvement of Races," which subject may be said properly to belong to the "science" of gardening. To-day I have the pleasure of submitting to you my thoughts "On Colour in the Tree Scenery of our Gardens, Parks, and Landscapes," and here I find myself dealing more directly with the "art" of gardening. While fully recognising the progress, both in the art and science of gardening, which has taken place in my day, I yet think that in this outlying but important province, our professors have not made so free and effective a use as they might have done of the various tints of foliage which are to be found amongst trees and shrubs. Lest I should be misunderstood, permit me to state at the outset, that I hold the prevailing green with which the earth is clothed to be the best colour that could have been devised for the purpose, as blue is the most appropriate colour for the sky. But the sky, which is beyond our reach and power, is naturally subject to constant and considerable variation, and is singularly free from monotony. It is not altogether, or long together, of one colour. There are light fleecy clouds continually breaking up the hemisphere of blue; varying in substance and colour; sometimes hanging motionless, but oftener sailing noiselessly along, more or less rapidly, and every moment changing in form. Then there are the dark thunder clouds, and the golden, silvery, purple and roscate hues, which often give both life and brilliancy to the morning and evening sky.

But we have the power given unto us to vary and adorn the surface of the earth, and I would here invite public attention, and invoke the artist's aid in behalf of colour. There appears to me a monotony on the face of our English landscapes arising from one uniform and all-pervading colour—green. This monotony I would seek to remove by the introduction of trees with purple, white, and yellow leaves. With the same end in view, I would also plant more freely the transitory red, yellow, brown, and purple tints of spring and autumn, supplementing these effects by the introduction of berry-bearing trees—trees with white, red, black, and yellow berries, and trees with white, red, and yellow bark for winter ornament. With these preliminary remarks I shall endeavour to show—1st, that the object I seek is desirable; next that it is attainable, and shall conclude with a few general remarks and brief examples in support of my views. I am free to confess that there is nothing in the whole range of Nature which yields me more pleasure than the contemplation of a beautiful landscape. To stand on some elevated spot in the English or Scotch lake district, for example, and look down on a broad and varied expanse of country; to row upon the surface of the lake, and look upwards upon the towering masses of rock and tree; to trace the lake shores, the lake islets and waterfalls, is, I believe, a recreation of a higher intellectual and more æsthetic order than the many who have not practised it might, at first sight, take it to be.

A highly cultivated American gentleman once said to me, "England is a series of varied and improved landscapes. Now and then in remote districts one catches a glimpse of Nature, unaided and unadorned, but generally throughout the length and breadth of the land high art has been so skillfully applied as to effect the artist's object without leaving behind any traces of the artist's hand. But I miss the brilliant autumnal glow of the American forests: your landscapes lack colour." This very nearly expresses my ideas of English scenery; the natural beauties of our landscapes have in many cases been improved or developed at a sufficiently distant date, that the old and the new have become blended in one harmonious whole, leaving no strong lines of demarcation between the work of Nature and the work of Art; but the landscapes are generally cold and monotonous—wanting in variety and colour.

If we proceed to analyse a beautiful English landscape we shall find it composed of diversity of surface, light and shade, wood, water, rock,

and many minor accessories, which may or may not be present, either singly or in combination. These I mention not to dwell upon, but to dismiss, as the recognised features of the landscape. My business at present is with tree scenery, and principally with one feature of it—colour. Our earth tints are prominently neutral, often sombre, and to correct this should, in my judgment, be a leading idea with the true artist in landscape gardening. A piece of country, however beautiful by nature; a garden, however perfectly planned, yields more or less pleasure according to the skill and taste exercised in the planting, just as the proportions and beauty of the human form are improved or otherwise by the style of dress—trees, shrubs, and flowers constituting, in fact, the exterior dress of the garden and the landscape. Now, it must be patent to those even who are but slightly acquainted with this subject, that the labour of our plant collectors abroad, and plant cultivators at home, have placed within our reach many trees with coloured leaves—purple, yellow, and white—of various shades, and I hold that these colours should be so blended with the prevailing green as to remove the monotony which at present obtains. That the effect of colour in the landscape would be generally appreciated was once brought home to me in a peculiar manner. I was riding in company with some friends through the park at Chatsworth, in Derbyshire. Suddenly we sighted a tree with reddish-brown leaves rising from the green sward, and surrounded at some little distance with the usual green trees. Remote as it was, we could not at the moment make it out, but all admired it, and agreed that it was at once telling and beautiful. Led by admiration as much as by curiosity, we approached it, and discovered a dead tree retaining its reddish brown withered leaves.

I think that any cultivated observer who may dwell ever so briefly on the tree scenery of Great Britain will admit that the contrasts of colour, weak and little varied as they generally are, present to him one of its most pleasing features. If, then, the slight existing variation of colour, restricted principally to the contrast between light and dark green, is admitted to be an element of beauty, may we not justly infer that we should gain something if we varied and increased the contrasts by the use of stronger and more distinct colours? I think, then, that I may fairly assume that, on a free and full consideration of this subject, it will be generally admitted that a greater variety of colour would be an improvement in the tree scenery of our English gardens, parks, and landscapes.

I have next to show that the object I seek is attainable. The arrangement of the colours of flowers in the flower garden has of late years been worked out with wonderful skill and effect. What were our flower gardens in this respect thirty years ago? I remember that results predicted then were considered impossible by the many, although they have been accomplished, and more than accomplished, long ago. Now, as far as I am aware, no one has yet applied the same principles in the arrangement of trees and shrubs with coloured leaves. I have been told that it cannot be done. But after a long study of the question and numerous experiments, I have come to a different conclusion, which I submit with all deference to those who think otherwise. I believe that here, as in the flower garden, there only needs a beginning, and progress will be rapid and success certain.

Many years ago I formed a collection of pictorial trees and shrubs, and planted them closely together, with the view of watching their development and eradicating those kinds which might prove undesirable on more mature acquaintance. This plan I vigorously pursued, and now find myself in possession of a select list, which I believe is sufficient to carry out all that I shall advance.

In addition to the ordinary or prevailing green, I find that I have five colours, or tones of colour, with which to work:—1, Light green; 2, Dark green; 3, Reddish purple; 4, Yellow or golden; 5, White or silvery; and these may be combined in a variety of ways. Dark bluish green has a good effect when placed in contrast with light yellowish green; white with dark green; reddish purple with light green; reddish purple with yellow; yellow with dark green. And these contrasts by no means exhaust our resources. I merely quote them from among a number of experiments which I have actually tried and found agreeable to my taste. I have, indeed, no intention here of laying down any precise or definite rules for the application of these principles; I aim at no more than to show that the materials in colour exist, leaving their combination to be dealt with by the ingenuity and industry of a cultivated taste. It would be chimerical to suppose, unfair to expect, that any person taking this subject in hand without previous study, or without the fullest acquaintance with the materials which exist—some of them newly introduced—would at once realise any great measure of success. To such an individual the scheme would probably appear utopian. He might, by a momentary effort, call up in his mind the short list of old and familiar trees with purple, white, and yellow leaves,—the purple Beech, the white Poplar, the variegated Turkey Oak, and some few others still among the most valuable, but so few in number that he would dismiss the subject as impracticable. But unless familiar with the black and yellow Oaks, the yellow Elm, Acacia, and Alder, the white-leaved Acer Negundo, and the many beautiful Maples recently introduced from Japan—the host of richly variegated trees only now becoming plentiful,—in a word, unless familiarly acquainted with the latest introductions of this kind, he would, I submit, be drawing his conclusions from incomplete information.

In order to bring my views to a practical test, I have here a diagram,

in which I have merely sought to obtain the identical colours existing among trees and shrubs, and must refer you to the specimens exhibited to show that these colours really exist. This diagram, hastily executed, will perhaps also give some idea of the effect of the arrangement of the colours which we possess. The light green here is supposed to represent the Larch, the dark green the Yew, the reddish purple the purple Beech, the yellow the golden Oak, and the white variegated Acer Negundo. There is also introduced here the ordinary green of Nature, which may fairly be taken as the groundwork of our operations.

Now, I am well aware, and would not ignore the fact, that the colours of the leaves of trees are influenced in some degree by cultivation and soil, but this does not affect our argument, as in the majority of cases they still bear the same relation to each other.

I have now to offer a few general remarks, with brief examples in support of the views which I have advanced. Let us remember that we are working with pictorial trees for pictorial effect. We may have spring pictures, summer pictures, autumn pictures, and permanent pictures. Summer and permanent pictures are the most valuable because of their greater durability. Specimens of these are before you, and a list of their names will be given at the end of this paper. The materials for spring and autumn pictures can only be shown in spring and autumn. The varying tints of the unfolding leaves of some trees in spring, and the glowing colours of the leaves of other trees in autumn, must be familiar to all observers, and these trees are beautiful in their seasons, whether regarded individually or in combination. But they are transitory. The varied and telling colours of spring, ordinarily, quickly subside into the universal green; and the bright leaves of autumn fall speedily before the frost and gales of that season. Yet both are desirable. The warm red and yellow tints of the unfolding leaves are peculiarly cheering in the cold days of early spring, and should be introduced freely when planting. The splendour of the American forests in autumn is a theme on which many travellers have loved to dwell, and leaves from these forests may be seen in that admirable institution, the South Kensington Museum. The trees we have long had under cultivation, and they are not only available but capable of being wrought up with magnificent effect in this country. Among the most effective of spring trees the Corstorphine Plane (*Acer Pseudo-Platanus flavo-variegatum*), yellow; the *Acer colehiem rubrum* (red); the purple Horse Chestnut (*Æsculus Hippocastanum purpureum*), purple; and the Silver Poplar (*Populus argentea*), white, may be instanced. The shades of green at this season are also innumerable, although for the most part gradually subsiding into one nearly uniform tint. The brightest among the leaves of autumn are, perhaps, the Scarlet Oak (*Quercus coccinea*), the Liquidambar (*L. styraciflua*), the Stag's-horn Samach (*Rhus typhina*), the *Ostrya virginica*, and several varieties of Cherries, Pears, and Maples; these usually die-off bright red. Of yellow shades may be instanced the Lombardy and Ontario Poplars (*P. fastigiata* and *P. canadensis*), the Norway Maple (*Acer platanoides*), the Horse Chestnut (*Æ. Hippocastanum*), the *Salisburia adiantifolia*, the Lime (*Tilia europæa*), the Tulip Tree (*Liriodendron tulipifera*), the White Mulberry (*Morus alba*), the *Gleditsia tricanthos*, the *Magnolia tripetala*, the *Juglans ansara*, the *Acer Negundo*, the *Kolreuteria paniculata*, the Birch (*Betula alba*), and certain varieties of Cherries, Pears, Thorns, and Maples.

As examples of planting for pictorial effect, nothing can be more beautiful in the flower garden than pillars or columns of Ivy, provided that they be appropriately placed. Here we have dark green, light green, green blotched with gold, and green edged with silver, all calculated to form permanent pictures. Standard and pyramidal golden Yews and golden Hollies also form beautiful permanent pictures in the garden. All permanent pictures are of course also winter pictures, but the common Beech (*Fagus sylvatica*) deserves special notice; it holds its reddish brown leaves throughout the winter, and this colour stands in warm and beautiful contrast with the Pines and other evergreens at that season. The white bark of the Birch, the white, purple, and yellow bark of certain species of Willows, the red and yellow berries of the Holly, and the yellow and black berries of the Privet, are also invaluable for winter decoration. I have often admired the effect of three large trees placed in juxtaposition in a garden in my neighbourhood, whether by accident or design I have no means of ascertaining. Near the bend of a river is a Weeping Willow, the pale green drooping branches appearing in the distance almost to sweep over the stream. Behind rises a mass of the dark feathery Yew, the plumes of foliage waving in beautiful contrast of motion, form, and colour. Still farther behind there appear in spring rigid masses of Apple blossom, the snow-white crimson-tinted flowers blending in beautiful contrast with the dark and pale green of the Yew and Willow. Here we have the evergreen and deciduous forms in combination, but they are most effective as a spring or summer picture. Of all the errors to be avoided in the association of colours, I would caution the planter against an arrangement that should present a "spotty" appearance. Broken lines, or irregular shapes of colour, appear to me more desirable in forming plantations or belts than figures with a more easily definable outline. On the face of belts or woods, three or five plants of a kind may be planted in a group, the outline being so broken that there are bays or promontories. In parks and gardens, single trees or groups of trees, each group of a distinct colour or shade of colour, would seem most appropriate. In working out these ideas we must never lose sight of harmony, remembering,

however, that there are harmonies of contrast as well as of analogy. There is another point which should on no account be lost sight of. There are some trees the effect of which is beautiful close to the eye, but which lose their distinctive character in the distance. Such are more appropriate to the garden, where brought in close contact with the eye, than in the distant landscape. But there are others which lose little or nothing from a distant view, and these facts must be taken into account and acted on when planting. As a rule, trees with variegated leaves are best placed near to the eye, and those of one uniform tint are most effective in the distance. I have already instituted a comparison between the colours of flowers and the colours of leaves, but there is an important difference in them, which I must not omit to mention. The colours of flowers are often so bright and pronounced, that certain of them cannot be judiciously brought into close contact; they require an intervening mass or line of some intermediate or neutral colour to render the effect agreeable and satisfactory. Not so, however, with the colours of trees: they are so subdued in tone that the association of the strongest colours does not produce violent contrasts. Again, for this very reason the colours of leaves being less bright than those of flowers, it becomes necessary here to accomplish by breadth of colour that which, with flowers, is effected by brilliancy of tone. Thus it follows that great breadths of scenery may be dealt with most effectively. It is, indeed, a mere question of outlay, and nothing more, whether variety of colour shall or shall not be extended from the garden to the outer pleasure ground and shrubberies, the hills of plantations, the outskirts of woods and forests, and the most distant mountains and plains.

A.—SUMMER PICTURES.

1. Light Green.

<i>Larix europæa</i> .	<i>Tilia europæa</i> .
<i>Taxodium distichum</i> .	<i>Catalpa bignoniifolia</i> .
<i>Gleditsia triacanthos</i> .	<i>Cobanea Fendleri</i> .
<i>Juglans laciniata</i> .	<i>Platanus occidentalis</i> .
<i>Acer Negundo</i> .	

2. Dark Green.

<i>Fraxinus crispata</i> .	<i>Æsculus Hippocastanum</i> .
<i>Pinus montophylla</i> .	<i>Euonia nigra</i> .
<i>Alnus glutinosa</i> .	<i>Fagus sylvatica</i> .
<i>Cytisus Laburnum</i> .	<i>Ulmus, various kinds</i> .
<i>Pyrus Aucuparia</i> .	<i>Quercus Cerris</i> .

3. Reddish Purple.

<i>Fagus sylvatica purpurea</i> .	<i>Corylus Avellana purpurea</i> .
<i>Ulmus campestris fol. purp.</i>	<i>Quercus pedunculata purpurea</i> .
<i>Acer Pseudo-Platanus fol. purp.</i>	<i>Quercus nigra</i> .
<i>Acer japonicum atropurpureum</i> .	<i>Berberis vulgaris fol. purp.</i>

4. Yellow or Golden.

<i>Quercus Cerris variegata</i> .	<i>Sambucus nigra aureo-variegata</i> .
<i>Robin var. Concordia</i>	<i>Symphoricarpos vulg. fol. aureis</i> .
<i>Fraxinus aucubifolia</i>	<i>Spiræa opulifolia lutea</i> .
<i>Castanea vesca variegata</i> .	<i>Robinia Pseudo-Acacia aurea</i> .

5. White or Silvery.

<i>Populus argentea</i> .	<i>Pyrus salicifolia</i> .
<i>Acer Negundo variegatum</i> .	<i>Salix argentea</i> .
<i>Tilia argentea</i> .	<i>Shepherdia argentea</i> .
<i>Pyrus vestita</i> .	<i>Siphocampylus rhamnoides</i> .

B.—PERMANENT PICTURES.

1. Light Green.

<i>Pinus pyrenaica</i> .	<i>Ilex hibernica</i> .
<i>Cedrus Deodara</i> (the green variety).	<i>Juniperus thurifera</i> .
<i>Abies orientalis</i>	" <i>virginiana</i> .
" <i>rubra</i> .	" <i>chinensis</i> .

2. Dark Green.

<i>Pinus insignis</i> .	<i>Quercus Ilex</i> .
" <i>austriaca</i> .	<i>Cerasus lanistatica</i> .
<i>Picea Nordmanniana</i> .	<i>Phillyrea</i> .
<i>Araucaria imbricata</i> .	<i>Garrya elliptica</i> .
<i>Cupressus Lambertiana</i> .	<i>Hollies and Yews, various</i> .

3. Purple.

There are no suitable purple evergreens, consequently this colour is restricted to summer pictures.

4. Yellow or Golden.

<i>Abies excelsa fineolensis</i> .	<i>Thuja elegantissima</i> .
<i>Cupressus thyoides variegata</i> .	<i>Taxus baccata aurea</i> .
<i>Ilex Aquifolium aurea</i> .	<i>Enonymus japonica flavescens</i> .
<i>Thuja aurea</i> .	<i>Retinospora pisifera aurea</i> .

5. White or Silvery.

<i>Cedrus Deodara</i> (the glaucous variety)	<i>Abies alba glauca</i> .
<i>Pinus excelsa</i> .	<i>Ilex Aquifolium argentea</i> .
" <i>monticola</i> .	<i>Juniperus virginiana glauca</i> .
" <i>nivea</i> .	<i>Rhamnus Alaternus fol. argenteis</i>

—W. PAUL, Paul's Nurseries, Waltham Cross.

Mr. Barron, of Barrowash, remarked that all delight to see a pictorial landscape if the picture is a pleasing one, but unfortunately this had not been so prominently brought forward in practice as it should be. If we considered the varied acquisitions which had come into our possession through recent introductions, every pigment necessary to form the finest landscape would be found. We had within reach a great variety of trees both for pictorial effect and for profit, and he was glad to see that arboriculture had engaged special attention. It was a subject that should occupy the attention of all.

Mr. D. T. Fish complained that the ruin of our landscapes had

been the mixed system of planting, sufficient attention not having been paid to distinctness of colour. He did not advocate the introduction of so much green into our gardens.

JUDGING FRUITS.

Dr. Hogg, after a few preliminary observations, said—

Though the judging of fruit has on various occasions occupied the attention of those interested in the subject, and has from time to time been discussed in the public prints by those most competent to deal with it, I am not aware that any common understanding as to the bases on which fruit-judging should rest has yet been arrived at. Notwithstanding this want of a written law on the subject, the practice of judging fruit is followed with results which, though not always agreeable to unsuccessful competitors, are, upon the whole, generally accepted and acceptable.

It is not my intention to submit anything to this meeting which can be regarded in any light as a solution of the question, Upon what principles ought fruit to be judged? This I will leave to be dealt with by those of my audience who are sufficiently versed in the subject, and who feel themselves competent to do so. All that I shall do is to state the motives which actuate me in coming to the conclusion I do when I am acting the part of a fruit judge, leaving others to set up any other code they may think better and more in accordance with their own views.

And first, let me remark that, in judging fruit at exhibitions, I think we ought to do so upon different grounds to what we would judge it at our own tables. We must bear in mind that exhibition fruit is exceptional, and is produced by the greatest effort of the horticultural skill of the exhibitor. It generally receives an amount of attention which he cannot afford to bestow on a general crop, provided his establishment is an extensive one; and we ought, therefore, to regard the exhibition fruit of a gardening establishment very much as we would the exhibition ox—as the exceptional animal on the farm. In judging fruit, therefore, we must first look to those points which exhibit the greatest amount of horticultural skill, and the first of these are size and symmetry.

In judging size and symmetry we must deal with each variety on its own merits. It would not be fair, for instance, to judge on the same grounds a bunch of Buckland Sweetwater Grape and one of White Muscat of Alexandria. That of Buckland Sweetwater may be much larger than, and equally as handsome as, that of Muscat of Alexandria, and both may be in every point what gardeners call "well finished;" but the skill required in producing such a bunch of Muscat of Alexandria being much greater than what is required to grow the Buckland Sweetwater, and the Muscat of Alexandria being a much superior fruit, I would give the preference to the latter, although inferior in size to the former. The same may be said of Black Hamburgh and Black Prince shown in the same class, though not on the ground that Black Hamburgh requires greater skill in the production of it, but because it is a superior fruit.

It matters not what description of fruit we may be judging; be it Grapes, Pines, Peaches, or any other fruit, size and symmetry are the features which first attract our attention, and therefore to size and symmetry, but not to size apart from symmetry, I attach, perhaps, the greatest importance when other points are not greatly deficient.

The next important feature is colour, requiring much skill in the development of it. This is by some regarded as of even greater importance than size and symmetry. I am rather inclined to give colour second place, except when it is unusually fine, and the difference of size and symmetry between the competing fruit is not great. In such a case I would certainly give the preference to colour, for I conceive that in such circumstances there is a greater exhibition of horticultural skill in producing the highly-coloured fruit than in producing the larger, because it betokens attention to the maintenance of the just equilibrium between the action of the roots and that of the leaves, and a knowledge as to the crop the plant is capable of producing, without which I conceive no fruit can be well and perfectly coloured. One may feed and force a plant so as to induce it to produce large and showy fruit, but unless the treatment is so regulated as to preserve the just equilibrium between the root which serves as the mouth and the leaves which perform the functions of digestive organs, there is no guarantee either for high colour or perfect flavour, which generally go together. Still I say when fruit has not an objectionably bad colour, and is not deficient in flavour, but has size and symmetry much in advance of another which possesses higher colour and better flavour, but is much inferior in size and symmetry, I would certainly give the award in favour of the larger fruit.

The next point on which I have to touch is flavour; and here I know there is a great diversity of opinion. Some hold that the beginning and the end of all fruit culture is flavour; no matter how large or how small, or however badly coloured the fruit may be, if flavour is obtained the grower has got all he has ever striven for. Now that is very well when fruit is grown merely for private use; and so long as the palate is satisfied there is no other desire to be gratified; but we are now discussing the merits of exhibition fruit, into which the whole energy of the cultivator is thrown to develop, not one, but every feature of his production, and the greatest display of cultural skill is to succeed in gratifying the mind as much through the eye as through the palate. It is not to be supposed that I depreciate flavour. On the contrary, I consider it an important point in making awards to

exhibition fruit; but I think it ought only to come in when the competition is otherwise so close that another point is required to turn the scale.

There is only one exception I would make on the question of flavour, and that is in judging Melons, which, if they have not flavour, have nothing whatever to recommend them. They may be Vegetable Marrows, or Pumpkins, or any other vegetable production, if flavour is absent; and I think experience will testify that if the flavour of a Melon is even but indifferent, then the fruit is not worth eating, and hence I think all Melons ought to be cut, and judged by flavour only.

In the report of the Rev. S. Reynolds Hole's paper on the Rose, at page 65, he is made to say, "The best stock for the Rose was the Manetti." His remarks were these:—"What is the best stock for the Rose? If you purpose to exhibit, grow it upon the Eriar, and show it the year after budding. If you desire a beautiful Rose garden, and do not care to exhibit, grow a large proportion of your Rose trees on their own roots. These are prettier, because more natural in form, more abundant in flowers, more enduring, and therefore more economical. Some Roses attain their full perfection on the Manetti stock, and all do well on it in our lighter soils."

ROYAL HORTICULTURAL SOCIETY.

AUGUST 3RD.

It was probably owing to the great heat which has prevailed for the last month that the subjects for which prizes were offered on this occasion were but poorly represented, both in respect to number, and as regards the variegated Pelargoniums, for the most part, in quality also. The flowering specimens of the Nosegay and double-flowered varieties were on the whole much better, although some of the former had suffered greatly from the heat. The subjects brought before the Floral Committee constituted the great attraction of the day, and the Council room, where they were exhibited, presented an unusually gay appearance for the end of the London season.

In Class 1, for the best Golden-variegated Zonal (Tricolor) Pelargonium, Messrs. E. G. Henderson & Son were first with the Rev. E. R. Benyon, the plants very well grown and finely coloured. The second prize went to Mr. Mann, Brentwood, for Gold Crown with a dark zone flushed with bright rose. The third prize was taken by Mr. Stevens with small plants of Kaling Royal.

Class 2 was for one Silver-variegated Zonal (Tricolor) Pelargonium. The first prize went to Messrs. E. G. Henderson & Son for well-grown plants of Lass o' Gowrie; the second to Mr. Turner, for Mrs. Ramsby; and the third to Mr. C. Edmonds, Hayes Nursery, for Hayes Royal. Mr. Mann exhibited Leader; Mr. Turner Miss Pond and Princess of Wales.

In Class 3, one Gold and Bronze (Bicolor) Zonal, Messrs. Downie, Laird, & Laing were first with Imperatrice Eugénie, one of their highly-coloured kinds. Mr. Cannell, of Woolwich, was second with Annie Keeler.

In Class 5, one Silver edged Pelargonium, Mr. Turner, who was the only exhibitor, was first with May Queen; and in Class 6, one Ivy-leaved Pelargonium, Mr. Turner was also first with Compactum, a neat-growing white variegated kind.

Class 7 was for one Nosegay Pelargonium in flower. The first prize was taken by Mr. G. Smith, Tollington Nursery, with Mr. Gladstone. Mr. Cannell was second with Master Christine, awarded a first-class certificate on June 8th, the plants being the same as those exhibited on that occasion, and still in good bloom. No third prize was given.

In Class 8, for one Zonal Pelargonium in flower, Mr. Mann was first with Lord Derby, and Mr. George, gardener to Miss Nicholson, second with Annihilator. The best double-flowered Pelargoniums shown in Class 9 were Marie Lemoine from Messrs. Downie & Co., and Madame Lemoine from Mr. Mann. These were good specimens.

FRUIT COMMITTEE.—G. F. Wilson, Esq., F.R.S., in the chair. Prizes were offered at this meeting for the best dish of early Plums. Mr. Douglas, of Loxford Hall, Uford, sent Early Green Gage; Mr. Beasley, of Ecton Hall, sent Early Orleans; Mr. Roberts, of Holwood, Beckenham, sent Early Prolific; Mr. Gilbert, of Burghley, sent Early Violet, and Myrobalan; and Mr. Porter, Syon Lodge, Isleworth, sent Early Morocco, and Early Orleans. Mr. Douglas was awarded the first prize; and the second fell to Mr. Porter. Dishes of McLaughlin, a large form of Green Gage, Woolston Black Gage, and Perdrigon Violet Hâtif, were sent from the Society's garden at Chiswick, all of which elicited the approval of the Committee. Mr. Gilbert, of the gardens, Burghley, sent a dish of Brown Turkey, remarkably well grown, but deficient in flavour. Mr. Gilbert also sent fine fruit of Noblesse Peach, which was of excellent flavour, and of Moorpark Apricot, also highly flavoured.

Mr. Dodds, gardener to Sir G. Smyth, Ashton Court, Bristol, sent a seedling Nectarine, which is said to be fourteen days later than Elrnge. The Committee were of opinion that the fruit bore a strong resemblance to Violette Hâtif; but in the absence of a knowledge of the flowers and leaves, the identity could not be settled. Mr. J. McLaren, of Ash, Surrey, sent a dish of fruit of his Prolific Raspberry, which received a first-class certificate last year, and which was this year commended on account of its flavour. Mr. Stowe, of Farnborough, sent

branches of Black Naples Currants, laden with fruit, and a dish of the bunches. The Committee awarded a special certificate for superior cultivation.

Mr. A. Henderson, of Thoresby Gardens, Notts, sent a Melon called Calder's Hybrid Notted Green-flesh, which was a large handsome fruit, but deficient in flavour. Mr. Meakes, gardener to R. Fowler, Esq., Petersham, Surrey, sent two fruit of Golden Perfection, of good, but not superior flavour. Mr. Sidney Ford, of the gardens, Leonardslée, Horsham, sent a fruit of Golden Perfection Melon, excellent in flavour.

Messrs. Minier, Nash, & Nash, seedsmen of the Strand, sent two dishes of the large Late White Tripoli Onion, and also of the large Red Italian Tripoli, all of which were grown in this country. The exhibition was so meritorious that a special certificate was awarded to them. Messrs. J. Carter & Co., of Holborn, sent samples of their Covent Garden Garnishing Parsley, with a splendidly curled leaf. This was much admired, and received a first-class certificate. Messrs. Carter also exhibited a long green-striped Cluster Vegetable Marrow. The habit of the plant is that of a bush, like that of the Bush Custard Marrow, and produces one fruit in the axil of the branches just over the stock. Mr. Gilbert, of the gardens, Buryhill, sent samples of the following Potatoes, remarkably well grown—Coldstream Early, Myatt's Prolific, Early Shaw, Milky White, King of Potatoes, and Silver Skin. Mr. Eckford, of Coleshill Gardens, sent samples of Potatoes to show that superabundance is the result of dry weather. Mr. Porter, gardener to E. Benham, Esq., Syon Lodge, Isleworth, sent a tray of vegetables. The same gentleman also sent a collection of five sorts of Potatoes.

Messrs. Lane & Son, of Berkhamstead, exhibited a collection of fruit grown in pots, to which a special certificate was awarded.

FLORAL COMMITTEE.—Mr. J. Fraser in the chair. From Messrs. E. G. Henderson & Son, St. John's Wood, came a basketful of Tricolor Pelargonium Rev. E. R. Benyon, a free-growing variety with finely coloured dark crimson zones flamed with bright crimson; Hydrangea japonica speciosa, with the leaves having a creamy white patch extending from near the apex to the leafstalk, and in the specimen shown from 1 to 1½ inch wide; the flower-heads have a bluish tinge. This is a very ornamental plant, and its merit was marked by a first-class certificate. The same firm also sent *Phlox densata elegans argentea*, with the leaves largely variegated with pale yellow, an ornamental variegated plant which may prove useful in borders; and a group of dwarf Antirrhinum from 6 to 9 inches high, and of different varieties. These received a special certificate.

From Messrs. Veitch & Sons came a large and fine group of plants, consisting of various elegant Palms, a handsome specimen of *Croton Veitchii*, *Dracena Cheloni* with leaves very beautifully coloured, *D. Gouffroyi*, *Oncidium*, *Cypripedium Veitchii* with seven fine flowers, *Croton maximum* and *Croton undulatum*, the latter with its dark-coloured leaves richly spotted and blotched with crimson and rose; *Zamia Lehmanni*, a very handsome specimen—for this a special certificate was awarded; *Maranta chinboracensis* and *Wallisii*; and a *Sciadophyllum* from New Caledonia, with large shining leaves with obovate leaflets. Besides these, *Pendrobium Bensonii*, *Cattleya Acklandia*, and *Saccolabium Blumei majus* were each represented by good specimens; and a special certificate was given to *Renaubera Lowii*, which is rarely seen flowering on so dwarf a specimen, but which had, nevertheless, a fine spike of its rich-coloured red and yellow flowers. A first-class certificate was given to *Bowenia spectabilis*, a Cycad with very handsome, shining, clear dark-green foliage. A special certificate was given Messrs. Veitch for the whole collection.

Mr. Bull sent *Croton maculatum*, with the leaves irregularly marked with rich pale yellow, which was in a much larger patch on the young leaves; several Palms; *Cycas Broughtoni*, a handsome species; *Syngonium Seemannii*, with dark green foliage beautifully variegated with silvery markings along the midribs and principal veins of the leaves; *Adiantum Seemannii*, *Dicffenbachia Wallisii*, *Macrozamia magnifica*, and *Lilium auratum Brilliant*, finely dotted with purple. First-class certificates were awarded to *Cycas Broughtoni* and *Macrozamia magnifica*.

Mr. J. Stevens, 4, Ealing Terrace, Ealing, contributed a splendid collection of Balsams, beautifully grown, and with flowers which for size were more like small Camellias than Balsams. The colours were chiefly scarlet and flesh, the mottled kinds were also very fine. For these a well-deserved special certificate was awarded. Mr. Windsor, gardener to J. R. Havenhill, Esq., Leytonstone, sent a number of hybrid Nosegay Pelargoniums of various shades of scarlet, and all producing large trusses; and Mr. George sent a similar collection, including several varieties with fine trusses.

From Mr. William Thompson, of Ipswich, came *Eriothera* or *Godetia Whitneyi*, a hardy Californian annual with flowers 2½ inches across, lilac rose, with a red blotch in each petal, the plant apparently of compact habit. For this a first-class certificate was given. Mr. Ford, Leonardslée, Horsham, sent Lady of the Lake white-edged Pelargonium, with a broad white edge, and Golden Pink, a yellow-edged kind.

Messrs. Carter & Co. received a special certificate for three baskets of cut blooms of double-flowered Pelargoniums neatly set up. Mr. Cunnell, Woolwich, sent cut trusses of various Zonal Pelargoniums.

From G. F. Wilson, Esq., Weybridge Heath, came a pot of *Lilium speciosum atropurpureum*, a beautiful deep-coloured variety, and which will soon be covered with a profusion of bloom. The same gentleman

also sent a cut flower-stem of *Lilium tigrinum flore-pleno*, a very fine variety of Tiger Lily with four rows of petals, also *Lilium Leitchii* with spotted pale yellow flowers. Mr. Turner, of Slough, exhibited an extremely beautiful variety of *Lilium auratum* dotted with deep purple, and the same colour shading into the golden bands. For this lovely variety a first-class certificate was given. Messrs. Downie, Laird, and Laing contributed a collection of *Phloxes* in very fine bloom, La Candeur, Mr. Charles Turner, and *Geant des Batailles* being especially remarkable. Messrs. Downie & Co. also sent *Monsieur Guldenschych*, salmon rose with a purple eye.

Messrs. Barron & Son, of Elvaston Nurseries, exhibited scarlet Zonal Pelargonium *Magnificum*, a large-trussed and large-flowered variety, which, from the abundance of buds, appears to be a variety that will flower in long succession. Messrs. Cutbush & Son, of Highgate, received a special certificate for excellently grown Cockcombs. Messrs. Standish & Co. sent a fine stand of Gladioli, and Messrs. Carter & Co. had a special certificate for a large collection of the same flower. A special certificate was awarded to Mr. Stevens, Reigate, for two pots of *Disa grandiflora*, which were very fine specimens of culture. Mr. Green, gardener to W. Wilson Saunders, Esq., sent *Agave auricantha*, a handsome plant; a new *Orchid* from Natal, with the small lanceolate leaves barred across with black spots, and the bracts of the lilac flowers similarly marked; and *Achimenes arzyrostrigma*, with very small white flowers. Mr. G. Thomson, Stanstead Park Gardens, Emsworth, was awarded a first-class certificate for a seedling *Lilium*, a hybrid between *L. auratum* and *L. speciosum*; the flowers bear most resemblance to those of *speciosum* in form, and are white without golden bands, and spotted with purple. This was named *Purity*, and received a first-class certificate, which it well deserved, being very beautiful.

Mr. Cattell, Westerbam, again exhibited *Tropaeolum Minnie Warren*, and Mr. Cripps, Tuubridge Wells, two stands of cut blooms of his fine *Clematis Crippsii*, from the open air. Mr. C. J. Perry, Castle Bromwich, was awarded a special certificate for a stand of seedling *Verbenas*. From the Society's Gardens at Chiswick came six seedling fringed *Petunias* and *Pteris serrulata major cristata*, a handsome crested form, which received a first-class certificate. Mr. W. Dodds, gardener to Sir G. Smyth, Bower Ashton, Bristol, sent *Heliotrope Miss Dodds*, which is stated to be a very free bloomer and of good habit, but neither that nor seedling *Pelargonium Miss Upton*, a free-blooming pink kind, was in proper condition to judge of. Messrs. Carter & Co. contributed cut flowers of *Sunflowers*, very large and perfectly double. Mr. Porter, gardener to E. Benham, Esq., Isleworth, exhibited cut flowers of seedling *Tropaeolums*, *Pentstemons*, *Zinnias*, and *Hollyhocks*.

A first-class certificate was given to G. F. Wilson, Esq., for his double Tiger Lily above noticed, and second-class certificates to Mr. Keynes for *Dahlia Incomparable* and *Flora Hyatt*. Special certificates were awarded to Messrs. Downie & Co., for *Phloxes*; to Messrs. Carter & Co. for a fine collection of *Gladioli*; and to Mr. C. J. Perry, of Castle Bromwich, for seedling *Verbenas*.

GENERAL MEETING.—G. F. Wilson, Esq., F.R.S., in the chair. After the usual preliminary business the Rev. M. J. Berkeley commented on the most remarkable plants exhibited. The first which occupied attention was *Renaubera Lowii*, shown by Messrs. Veitch under the name of *Vanda Lowii*, which was that given it by Dr. Lindley, and Mr. Berkeley read the following account of the plant given by Mr. Bateman in the "Botanical Magazine" for 1854:—

"A more remarkable plant is not to be found among the vast and varied tribe to which it belongs. While in stateliness of habit and in the length of its flower-spikes it stands quite unrivalled among the *Orchids* of the Eastern world, its greatest peculiarity is to be found in the constant occurrence of two entirely distinct forms of flower on the same spike. This extraordinary circumstance was first observed by Professor Reichenbach, who satisfied himself, after a careful examination of fresh specimens furnished from M. Reichenheim's garden, that the strange phenomena had nothing to do with the separate production of male or female blossoms, since the organs in either form were equally perfect. In the present case nothing can be set down to caprice, for that singular pair of tawny flowers is found at the base of every spike.

"This wonderful *Orchid* is a native of Borneo, whence it was originally sent to the late Mr. Low, of the Clapton Nursery, by his son (Colonial Treasurer at Labuan), in whose honour the species was named by Dr. Lindley. It has also been imported by Messrs. Veitch, in whose nursery, at Chelsea, I first had the pleasure of seeing the plant in bloom. It was not, however, until the autumn of the year 1862, when the species flowered in Mr. Rucker's collection, that any adequate idea could be formed of its beauty. A full account was published in the *Gardener's Chronicle* at that time, which would apply equally to Mr. Rucker's plant, as it might have been seen in September last, when it again burst into flower, and, if possible, in greater beauty and profusion than before.

"I gather from a memorandum received from Mr. Pilcher, Mr. Rucker's gardener, that the Wandsworth plant is already 9 feet high, and that it produced six spikes, each bearing from forty to fifty flowers, which lasted in perfection for a month. The spikes attained to such an extraordinary length that they had to be supported on props, and thus formed graceful festoons, under which a person might walk! The plant requires the heat of the East Indian house, and grows so freely that it seems almost to chafe at the comparatively narrow scope which the low roofs of modern *Orchid-houses* afford it.

"Dr. Lindley, who had only seen the specimens originally sent from Borneo, referred our plant to *Vanda*; but Reichenbach, who more recently had the advantage of examining living flowers, is decidedly of opinion that it falls more properly under the genus *Renaubera*; and as in this case I

quite concur in the view of the German Professor, I have not hesitated to substitute the name of *Renanthera* for that of *Vanda Lowii*."

It was, remarked Mr. Berkeley, a singular fact that the two tawny flowers are strongly scented, while all the others are scentless. The *Godezia*, shown by Mr. Thompson, of Ipswich, the hybrid *Lilium Purity*, and the unnamed *Natal Orchid* from Mr. Wilson Saunders's garden, were next referred to in highly commendatory terms, and Mr. Berkeley pointed out that the bracts of the last-named are striated exactly like the leaves. Mr. Berkeley concluded by pointing out to the meeting a curious specimen from the garden of Mrs. Lloyd Wynne, of Coed Coch, in which the pigmy *Abies claustralis* was seen to be reverting to the common Spruce, thus affording a proof that the supposition that it was a sport of that tree is correct.

The next meeting, in conjunction with the *Gladiolus Show*, will be held on the 17th inst.

DIFFERENT ROSES ON THE SAME STOCK.

I HAVE SEVEN varieties all doing well on the same stock—viz., *Gloire de Dijon*, *Paul Ferras*, *Sir Joseph Paxton*, *Prince Imperial*, *Caroline de Sansal*, *Charles Lawson*, and *Madame Charles Crapelet*. These are all ludded on a Rose of the *Multiflora* family, white or blush, and are growing on a west wall in front of my cottage. Your readers will remember the coldness of the weather in April and May, 1869, yet I cut beautiful Roses from this tree on May 15th, and again on December 25th. All the varieties are thriving, and they had an admirable effect last June when the various coloured flowers were out together. I may add that I had on the same stock *Général Jacqueminot* and a *Perpetual Moss*, but accidents happened to them, and they were pulled off.—C., Ireland.

EDIBLE-FRUITED RIBES.

THE enclosed fruit, which is of American origin, I have not before observed. It is said to be a hybrid between a *Gooseberry* and some sort of *Currant*; when ripe it is a pleasant sub-acid fruit, is very good for cooking and preserving, and has the great merit of always bearing a heavy crop, even when *Currants* and *Gooseberries* fail in the garden in which it grows.—W. D. Fox.

[This is one of the many interesting species of *Ribes* found in North America, we think *Ribes oxycanthoides*, although we cannot determine exactly with the fruit only. The fruit, as stated, is not unlike a small *Gooseberry*, and not unpleasant to eat.—EDS.]

GLASS WALLS.

EVERY extension of the use of glass has marked an improvement in the science and practice of gardening. The more glass used in the roof or sides of a house the greater the yield, the richer the reward. Gardening lingered long under the shadows of semi-opaque roofs of inferior and dear glass. The emancipation of glass from fiscal burdens marked a new and much higher epoch in cultivation. Within the last thirty years horticulture has advanced more than in three hundred years previously. The chief reasons of this rapid progress are the cheapness and plentifulness of glass. The improvement in quality has kept pace with the increase in quantity, until now good glass, but a few years ago the luxury of the few, has become a necessity to the many. Neither have we reached the limits of its use. The plentifulness of glass has stimulated invention. We are not using enormous quantities of glass for old purposes, but almost daily applying it to new uses. We are roofing our houses and draining our land with glass tiles; applying portable glass to wood and earthenware for the formation of miniature hothouses on the ground or the surface of our walls; covering the faces of these walls with glass screens, moveable or otherwise; and last, but by no means least, building the walls themselves with glass. This promises most important issues for horticulture, and will be a substantial boon to every one who grows fruit or flowers against walls.

Bank any plant up against an ordinary wall, and you weaken it in two ways: You deprive it of motion, and you rob it of light. The last is by far the more serious injury. Doubtless the vibration of plants in the open air is a strengthening process of more or less power, but the shutting-out of light is a much more serious and potent cause of weakness than the fixing of plants against walls, for light not only enables plants to assimilate their food, but to build it up into structure or produce; it at one and the same time transforms, extends, and consoli-

dates. By so much as you lessen the supply of light you weaken their assimilating and growing force. It therefore follows that plants on walls will as a rule be much weaker than those not on walls; and this weakness, born of semi-darkness, renders them liable to diseases, and exposes them to premature death. If, however, by any means plants against walls can be exposed to almost as much light as those in the open air, they will probably become nearly as robust and long-lived.

Now, by the use of glass for walls each side of the tree, and both sides of the wall, will be more or less fully exposed to the light. Transparent walls will banish the chilling coldness of northern aspects from our gardens. The sun, that hitherto wasted its strength upon dead bricks, will from henceforth be employed in the nourishment of living trees. Experiments have shown that the north side of glass walls is only a few degrees colder than the south side, and there will be but little difference in the intensity of the light upon the two sides. Were the glass perfectly transparent the difference in either light or heat on the two sides would hardly be perceptible; for though glass bends the rays of light or heat passing through it out of their straight course, it scarcely perceptibly hinders them. But the glass employed in the construction of these walls is rough plate weighing about 2 lbs. to the foot, and therefore not quite transparent: hence it arrests and retains a certain proportion of the heat, and radiates the remainder back into the air and down upon the ground. There may be some drawbacks incident to the very active radiation of glass walls. Probably they may cool at night faster than opaque walls, but this activity is not an unmixed evil. During hot weather the surface of glass will be cooler than any other wall. The heat that rebounds from this is not lost; much of it goes to warm the ground and the roots of the trees; and it seems probable that in practice it will be found the borders at the foot of glass walls will have a superior mean temperature to those at the bottom of any kind of opaque walls. This reserve of heat stored in the earth during the day, will be slowly given out at night to the protection of the trees on the walls.

The comparative coolness of glass walls during bright sunshine is also a great cultural advantage. Heterodoxical as it may appear, I am prepared to affirm that we lose more wall trees through an excess of heat than of cold. The sun scorches them on the surface of the bricks or stones with a dry heat of 100°, 120°, or 130°; they succumb, and then we mostly blame the preceding winter. The accumulated force of the sun and the bricks together in nine cases out of ten kills or ruins the trees that die suddenly or become the victims of fatal diseases. On glass walls, not only will the surface be cooler, but the trees perforce must be trained on a trellis from 2 to 3 inches from the glass. So placed, and with such an active radiation behind them, the trees will never be scorched. The advantages will also be wholly on the side of glass in the spring. Our great difficulty through February and March with such excitable subjects as *Peaches* and *Apricots* is to hold them back. While the flowers are within the buds they are safe; once they have come out, they are in danger. The absorptive powers of the brick wall hurry them forth into the cold biting weather. A hot day or two come, and the blazing sun, accumulating its whole force upon the surface of the wall, makes all the buds spring open; and then frost comes and feasts upon their tender beauty, to the wreck and ruin of our fruit prospects. Glass will act to keep the flowers within their scaly sheaths, where they are well-nigh invulnerable.

And then, consider for a moment the cleanliness, the elegance, and the beauty of glass walls. They hardly afford a hiding place for a thrips; they seem mirrors for the trees to admire themselves in; and their beauty, with the sunbeams leaping out and in, and bending down in all directions among the branches, is a sight that must be seen to be appreciated. Nothing could well be more uninteresting, if not positively ugly, than our opaque walls, and few things more neat and ornamental than glass walls; but they have also utilitarian merits of the highest order. Is space valuable in most gardens? It is. Glass walls will save about 8 inches out of every 9 occupied by brick or other opaque walls. Their strong framework of iron, felt packing, and slabs of glass, with or without a slate base, only occupies about 1 inch of space. They are easily erected, quickly removed, and conveniently portable. They can be had of any height and in any form, as straight, zigzag, square, &c. Being transparent, they may be placed closely together in blocks. By such arrangements an immense area of wall could be sheltered from spring frosts, and protected from birds, with the smallest possible quantity of canvas or netting.

But the thinness of these walls will not only save surface space, but also give up a large area of ground to the roots. No cumbersome and massive foundations will be needed for them to stand upon. The sharp dividing lines between north and south borders will be abolished. The roots of trees on both sides of the walls will turn to the warmth, and seek supplies of food from the most genial quarters.

Through the courtesy of the inventor and patentee, Mr. Charles Beard, of the Victoria Works, Bury St. Edmunds, I am enabled to give woodcuts of sections of his straight and zig-

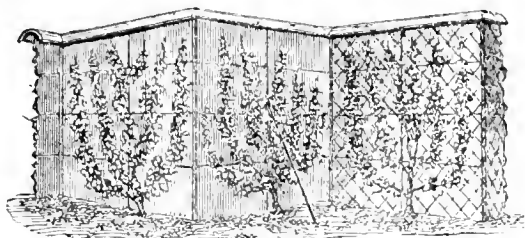

zag glass walls. As will be seen, they have an iron coping to ward off rain and frost. They are offered complete at a considerably less cost than 9-inch brick walls. Their complete portability will render them invaluable to tenants, who are often prevented

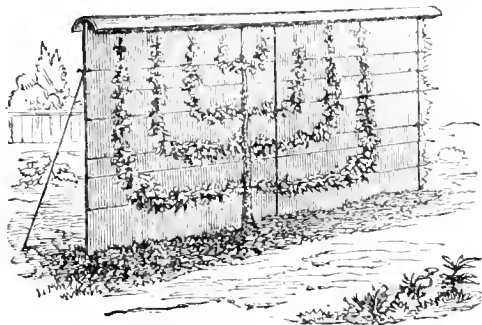

from building walls for horticultural purposes by the unsatisfactory law of fixtures, which leaves us free to put property down almost anywhere, but hinders us from taking it up again. These walls may be covered with fruit trees or flowers to-day, and to-morrow be resolved into their original elements of a bundle of iron, a crate of glass, and a roll of felt on ship or rail, and carried to any part of the world. For forming boundaries between small gardens, screens between different parts of the same domain, barriers between kitchen and flower gardens, partitions in offices or even dwelling-houses—different forms of glass walls will prove most useful. Within the garden they provide shelter without shading, and for this reason they cannot fail to improve the health and increase the fruitfulness of most of our wall fruit trees.

In a word, the glass walls threaten to drive the north pole out of our gardens, which some have protested against, inasmuch as this cold region has been useful in steering our deserts through the arctic regions of winter. But my idea of this matter is, that we may gather as late Plums, Cherries, and Pears off standards in cold aspects, as we can from north walls, and that in our climate it is a sheer waste of money to build walls to increase the cold. By the use of glass walls we shall double the extent of our genial climate, and may grow superior fruits successfully on both sides. Late winter supplies we even gather as good, or better, off espaliers, pyramids, or common standards, as from the backs of north walls.—D. T. FISH, F.R.H.S.

AMONGST THE ROSES AT SOUTHWELL.

"HAVE YOU seen Merryweather's Roses?" This is a familiar and oft-repeated query, and has escaped the lips of hundreds during the past few weeks in the midland counties, where the stands of this young aspirant to Rose fame have been a great centre of attraction by their sterling excellence and the high

honours achieved. In every case this season, save one, that these Roses have entered the competitive lists they have carried off the first honours. The exception was Loughborough, where they ran second in the race in a field of veteran rosarians.

Mr. Merryweather has brightened many otherwise bright horticultural exhibitions where, in "all-England" lists, in the short space of three weeks, he has carried off in his quiet modest manner ten first prizes. It was on the evening of one of these exhibitions, under the hospitable paragonage roof of "C. C. E.," that a trio met in solemn conclave, discussed and decided all about Roses, and settled that the next meeting—of the majority—should be held at the home of the Roses at Southwell. The train duly set me down, and permitted a stay of twelve hours "among the Roses." I have seen many collections public and private, but have not seen those of Messrs. Rivers, and Paul, and Radclyffe; so set it down for what it is worth when I say that I never saw a finer, healthier, better-managed lot of Roses than in the little nursery at Southwell. It was a veritable feast of beauty. It is the result of an alliance of great power and unlimited resources—viz., natural position and cultural skill. The part of the nurseries set apart for Roses may be termed one of Nature's miniature hollows, and is sheltered by the gradual rising of the ground on the one hand, and by distant trees on the other. The soil is a fine, sound, good-hearted, alluvial loam, just the kind to build up a sound constitution for the Rose.

But Roses here do not grow themselves, but are tended in a very practical manner from their very infancy by Mr. Merryweather, jun., for be it understood he is not of the kid-glove-and-lavender-water school. No, his gloves are pruning gloves, and his "rose water" is far more relished by the roots of his Roses than by delicate noses. To these let me commend that exquisite Rose La France, which has a delicious scent and is truly a grand Rose. The most attractive of the new Roses was, undoubtedly, Marquise de Mortemar, with examples of blooms $4\frac{1}{2}$ inches across, of a satiny white colour deepening towards the centre. A useful feature in this fine Rose is, that it seems to inherit the robust nature and free-blooming habit of its parent, Jules Margottin. Another worthy son of a worthy sire is Henry Ledchoux, from Victor Verdier. Montplaisir is very promising, though its outliving its parent, Gloire de Dijon, is very problematical. Two other fine new Roses were Thérèse Levet and Victor le Bihan, the latter quite first-rate in every respect. Of the general collection there were strikingly fine examples of Abel Grand, good all over; Black Prince, looking as bold as his great prototype; Comtesse de Jaucourt and Madame la Baronne de Rothschild in their calm beauty of colour and superlative foliage; Duchesse de Caylus, Madame Victor Verdier, Le Rhone, Marie Baumann, Maurice Bernardin, and Xavier Olibo, all extra grand, with Horace Vernet, Marguerite de St. Amand, Princess Mary of Cambridge, and Edward Morreu simply magnificent. But I must close my note-book for fear the matter may be interesting only to myself, just chronicling the remarkable vigour of a batch of Maréchal Niel, and the mildew-resisting powers of that fine Rose, Madame Clémence Joigneaux; not a particle of the parasite can be found on this variety in any part of the nursery. The Noisette and Tea section is well represented, a larger number being in pots of a handy portable size.

Mr. Merryweather's secret—no, he has no secrets—his basis of success rests with the sound practical attention bestowed from the very moment of planting his Briars. His power lies in his mulching, a practice in general gardening which cannot be over-estimated. The Manetti as a stock is a great favourite here, and as managed is an unequivocal success. Out of a batch of several hundreds or thousands worked on this stock, budded close to or below the ground, hardly a sucker can be found, and all are growing in the perfection of vigour.

To those who know little or nothing of Roses I append a short list compiled with great care on the spot. It is a selection of generally useful varieties, free growers, and free bloomers, and such as may be planted with confidence to give a good display in the garden; many good kinds are left out, even fine ones; its merit is, that no bad "miffy" growers are kept in. If six only are wanted, take the first six; if twelve, the first twelve, and so on. It contains nothing unproved or expensive, and may be useful to some one. The names are—Alfred Colomb, Charles Lefebvre, Madame la Baronne de Rothschild, Maréchal Vaillant, Marguerite de St. Amand, Maréchal Niel, Docteur Andry, Duchesse de Caylus, John Hopper, Madame Victor Verdier, La France, Madame Willermoz (Tea), Black Prince, Duc de Rohan, Duke of Edinburgh,

Exposition de Brie, Madame Clémence Joigneaux, Horace Vernet, Marie Baumann, Princess Mary of Cambridge, Victor Verdier, Madame Margottin (Tea), Souvenir d'un Ami (Tea), and Souvenir d'Elise (Tea).

For an amateur making a start, the above are recommended as good-all-round Roses. They are selected on their merits, regardless of the names of the raisers or the time at which they were introduced.

Taking a glance at the other parts of the nursery, we find some acres of fruit and forest trees kept well in hand, also a large stock of evergreens, and Conifers good and well managed. The houses are useful span-roofed structures. One is planted almost entirely with Mrs. Pince's Black Muscat Grape, and is bearing fine bunches. There is a splendid stock of pot Vines, and a healthy stock of Azaleas and Camellias raised and grafted on the spot. The general aspect of the nursery is neat and well-kept, the edges being close and trim, and weeds banished. The whole place gives evidence of skill, enterprise, industry, and perseverance, and by a continued exercise of these qualities the present rapidly acquired position will soon be left behind, and Mr. Merryweather will speedily occupy the front rank as a rosarian, and take a highly creditable stand as a general provincial nurseryman. He is animated by the spirit of his good neighbour the Rev. S. Reynolds Hole, and will in time excel. By the way, my pleasant day closed with two disappointments. I went to see the Canon's Roses—they were out of bloom; and the king consort of the queen of flowers was "out of town."—J. W.

PELARGONIUM PRESIDENT REVEIL.

THIS *Pelargonium* is of great merit as a bedding plant. To fully realise its value it should be planted by the side of other dwarf kinds; very dwarf and compact in its habit of growth, its chief superiority lies in its great abundance of compact trusses of vivid scarlet flowers, borne on short stout stalks just clear of the foliage. For so dwarf a plant the size of its flowers is remarkable, they being almost as large and quite as well shaped as those of Lord Derby. Its great utility as a front-row plant for ribbon borders, for small beds, and, indeed, for any position where dwarf-growing plants are required, should render it a general favourite.

In one or two former papers I have included this *Pelargonium* in my list of select sorts, and after having grown it for three years, so highly do I esteem it that I consider it fully merits this special notice.—EDWARD LUCKHURST, *Egerton House Gardens, Kent.*

WORK FOR THE WEEK.

KITCHEN GARDEN.

THIS is the time for laying the foundation of a sure supply of vegetables and salads for the ensuing winter. I shall suppose that all the spring and midwinter *Broccolis* have been planted some time, and that *Turnips* for October and November have also been sown; it remains to insure a continuous succession of *Canliflowers* and autumn *Broccoli*, also a full supply of *Salads*. The Cape *Broccoli*, although apt to sport, are amongst the most useful for affording a sure supply, provided the family are resident at their country seat from October to Christmas. Where such is the case the last planting should be immediately accomplished, and that should be a good breadth. A rich border should also be highly prepared for *Canliflowers*; these, planted immediately, will supply the table until Christmas if kept secure from frost. *Endive*, also, must be planted out with a liberal hand, likewise autumn *Lettuces*. Let no piece of ground remain vacant, and let a clearance be made forthwith of all decaying crops, or those which are unprofitable, supplying their place immediately with crops such as those just mentioned.

FLOWER GARDEN.

NOW that the effect of the present arrangement of the colours in the beds can be fairly seen, there is an excellent opportunity for noticing any mistakes, and determining upon the arrangement for next season, and this should be done without delay. When it is decided what each bed is to be occupied with next season, a plan of the garden should be made, writing the names of the plants on the beds according to the arrangement decided upon. This will be of the greatest service in showing at any time what quantity of each kind of plant has to be propagated, and unless some method of this sort be adopted, it is not unusual to find at planting-out time that there is a scarcity

of some plants and a superabundance of others; whereas those who have their plan to refer to can tell at a glance the exact number of everything required, and avoid mistakes in propagating too many of one plant and too few of another, and all the anxiety and confusion of working without a well-defined object in view. Dahlias will require to be gone over frequently to keep their side branches securely tied-in, for when left untied they are readily broken off by a thunderstorm. Hollyhocks must also be securely tied to their stakes. Continue to remove dead flowers from Roses, and give plenty of manure water to the autumn-blooming varieties. Those who can find time may pick off the seed-pods from their *Rhododendrons*; this will add much to the strength of the blossom in the next year. The Azaleas, of course, will benefit by the same process. During showery weather plant out all rooted Pink pipings. Should very dry weather occur they must be shaded and carefully attended to. It is advisable to pot a few pairs of the best sorts, and place them in frames; though the Pink is much harder than the Carnation. By adopting this plan they may be safely removed at any time, will make more roots, and, consequently, are more likely to form strong plants and to bloom well. Prepare a bed for the Tulip offsets, which must be planted in a few weeks, for many of the smaller ones, if kept out of the ground till the usual planting time, will shrivel and perish. It will, therefore, be necessary that amateurs and those commencing the fancy should immediately secure offsets of expensive or scarce sorts, if blooming roots cannot be readily or reasonably obtained, as most growers have commenced arranging their collections. Continue the directions given for Carnations and *Picotees* last week, and carefully prevent the seed-pods from contracting damp. Early application should be made for new or favourite varieties, in order that they may be potted off as soon as they are well rooted. Seedling Auriculas that have hitherto been kept in pans or boxes may now be placed singly in small pots; the soil used may consist of equal parts of sound turfy loam and leaf mould.

GREENHOUSE AND CONSERVATORY.

NOW that there is a profusion of flowers out of doors, it will not be possible to maintain the interest of the conservatory except by keeping it furnished with handsome specimens of showing plants. Azaleas, which do not seem inclined to start freely into growth, should, if possible, be placed in a moist situation, and be afforded every possible attention to induce them to make vigorous growth. Specimens in heat which have their bloom buds well formed, should be removed to a cool house or a sheltered shady situation out of doors, but they must be protected from drenching rains. Young plants which it may be desirable to increase in size as much as possible should, if they are setting their bloom, be stopped regularly over and encouraged to make another growth. See that the whole stock, particularly of plants in heat, is free from black thrips, and spare no trouble to keep the plants clear of this pest. Camellias which have fairly formed their bloom buds should either be placed out of doors or in a cool dry house, keeping them rather dry at the roots, in order to prevent their making a second growth, which young vigorous plants are apt to do if kept in a close moist situation after they have formed their flower buds. Any of the plants which may require more pot room should be repotted at once, so that the roots may take hold of the fresh soil before the blooming season, for these seldom bloom finely unless the pots are moderately filled with roots. If there are sickly or badly rooted specimens of other plants here they must be frequently examined for red spider, or they may become a nursery for that pest, and it will soon spread to adjoining plants. See that the young stock is not allowed to suffer from want of pot room, and attend carefully to watering, giving weak liquid manure to all plants in free growth that are likely to be benefited by it. Stove plants which may have been removed to the conservatory while in bloom should be placed in heat again as soon as their beauty is over, in order to permit the young wood to ripen. Plants which require repotting should be kept in-doors after shifting until the roots are established in the fresh soil. Attend well to young stock, which will now be growing freely. Keep the shoots nicely regulated and shaped as may be necessary to secure well-formed specimens, and use every care to afford these a moist atmosphere, sprinkling them overhead early in the afternoons of bright days, and reducing the amount of air. Chrysanthemums should now receive their last shift. Endeavour to keep them stiff in habit and to preserve their lower leaves. Any necessary amount of strength may be imparted to them, when the flower buds are formed, by good liquid manure. For the

greenhouse, look well after winter-flowering plants of a rather commoner order, such as Cinerarias, Verbenas, Scarlet Pelargoniums, Heliotropes, Roses, &c. Cinerarias must now be potted off, whether from seed or suckers, also Chinese Primroses, remembering to give the last shift immediately to those intended to blossom in October and November. Scarlet Pelargoniums and Heliotropes, in order to bloom, must be pottedbound.

STOVE.

Successions of Brugmansias, Clerodendrons, Euphorbias, and Poinsettias should receive a last shift directly, in order to provide a rich autumn display in the conservatory. Climbers on ornamental trellises should be occasionally cut back, in order to have a succession later in the season when flowers become scarce. A quantity of such plants as Thunbergias, Ipomoeas, Pergularias, Jasminums, Stephanotis, and Passifloras, &c., should be trained up ornamental trellises without delay.—
W. KEANE.

DOINGS OF THE LAST WEEK.

KITCHEN GARDEN.

THOUGH there have been next to deluges at places not far distant, we have only had showers so soft as more to resemble dew than rain on several mornings; and this, along with cooler weather, has given everything a rest, if not some encouragement to growth. Nothing could so well show the advantage of a syringing overhead in hot weather, where it could be given, as these misty showery wrappings in the morning. The whole tops of the plants were so swelled out with the gentle bedewings that they stood the sun well. We feel sure that many plants would have been completely burned up but for the change in temperature, these drizzling dews, and shading and mulching. It was pleasing to note how even a mulching put on roughly assisted plants that could hold their own with great difficulty. Leaves that were prostrate one day held up their heads the next, and that when there was no more difference as respects the sun heat than there was between the 22nd and 23rd ultimo, and where no watering of any kind could be given. If the mulching was short and put on rather roughly it acted better than longer litter, though that, too, helped. Our theory for this is, that the shorter litter, though keeping the sun from so fiercely acting on the soil beneath, did not, like a surface-watering, arrest the rising of moisture from considerable depths, and then the closer texture of the shorter litter kept that rising vapour about the roots instead of permitting it freely to escape into the atmosphere. By such means, and the help of some sewage water from the 25th and onwards, until that, too, was exhausted, we feel that now we can breathe somewhat freely again, and hope that the worst of the season is past, as the longer and colder nights will give us refreshing dews.

This season ought to be a lesson to many. We know of some farms where several horses have been employed every day in drawing water in barrels for a distance of from three to four miles. Syringing or engineing any kind of wall trees has been with us quite out of the question.

We dug down a large quarter of three-year-old Strawberries, and found the ground so hard that neither spade nor fork was of any avail, but we had to use the pick to break it up, and then to turn it over with the spade when broken. This ground, though so hard, was not so dry as ground whence crops of vegetables had been taken. The tops of the Strawberries and the mulching given had prevented in this respect the free action of the weather, but we never recollect finding the ground so hard. We were half inclined to clear off the Strawberries, make holes with a crowbar, and plant in the firm soil, as thus thus frequently Broccoli and other vegetables do well; but then we thought of the wheeling involved in clearing off the large crowns of the Strawberry plants, and the manure that would also thus be lost, so we resolved on trenching all down. When well broken and levelled we rolled the ground well, and then drew drills, and planted Broccolis, Borecoles, and Brussels Sprouts in the usual way, first watering them well in beds, lifting and soaking them, and then watering after planting with a little sewage water. This will be our second main planting. The first is pretty well holding its way in defiance of the dryness, the watering of sewage in their case having been given to the roots and not over the ground. In such weather as we have lately passed through, all surface-watering was worse than useless, unless it was merely given for the purpose of refreshing the foliage, or given in such quantity and manner as thoroughly to reach the roots of the plants.

We would have used much more water than we could obtain,

but our observation and experience tell us that millions of gallons have been need in gardens to the injury rather than the benefit of the crops.

Sowed Lettuces, Radishes, Turnips, and a few Cauliflowers for early work, reserving our main sowing until the end of the month. By means of sewage, &c., we sowed in damp soil, and covered over with dry soil, for reasons several times given. Our Dwarf Kidney Beans have done well under this treatment with little or no watering. The Scarlet Runners have grown and bloomed very well, but they have not set so freely as we should have liked. Taken altogether, we suffered more from the heat and excessively bright sun of July 22nd than in all the days of the summer. On that day myriads of Scarlet Runner blossoms fell, as if there was nothing to support them. Now they seem all right with mulching, and we have no doubt will be benefited by sewage water if the warm weather continues.

We shall most likely sow a few rows of Spinach and Onions for the earliest winter crop by the time this is in print. The Onions with us, though plentiful, will be small, owing to the dryness. The spring-planted ones, though fair, are nothing to what we have had them. A good rain would increase the size of all these useful bulbs. We shall have none this season from 10 to 15 inches in circumference, even with the advantage of a heavy rain. Fine rains in June are what tell most on the Onion crop. Were we sure of their coming, and just when they were coming, a slight dusting with guano or horse dust between the rows, will have an astonishing effect. On the other hand the dressing with guano, if dry weather succeed, will do more harm than good. We gave a slight dressing of superphosphate and sewage water to an early piece of Onions planted out in spring. The state of the atmosphere and the readings of the barometer led us to expect a plentiful rain. Had the rain come we should have gained our purpose. We only had a few drops, and our kindness in other respects did more harm than good. We do not believe our sewage watering reached the roots, and the damped surface did the mischief. It kept the roots dry when they might have had plenty of moisture, as it passed them to escape into the atmosphere. In this case the tops soon began to show signs of exhaustion. The bulbs will only average some 3 inches in diameter. If we had merely let them alone they would have been larger. If the expected rain had come, they would have been much better still. The watering we gave would not have gone above an inch or so deep—a mere nothing to the rooting of an Onion, but a great help if only the heavy rains expected had come.

During the week we have seen some nice Onions at the cottagers' show at Woburn, but though fine they exhibited traces of the dry season. We have generally thought that we would not be much out of the way if our crops at all corresponded with those of our friends, Mr. Manning, of Tingrith, and Mr. McKay, of Woburn Abbey. In both cases their general crops of Onions will not be as they used to be in better seasons, though there would be plenty. At Woburn we noticed a very fine piece of winter Onions in a border. As a merely passing notice, we should judge many of the bulbs were from 4 to 4½ and more inches in diameter. We know the garden is pretty well supplied with water, but we do not know whether these had any given artificially or not. Some weeks ago, however, they had one good soaking rain.

Cauliflowers.—Two gentlemen the other day took notice of a border of Cauliflowers, one of them a gardener, the other a nurseryman, and the first especially well conversant with the ideas of watering we have fully set forth in these pages. This border is something like our fifth succession, for where there is little ground and a large establishment, the supply is best made, not by great glut, but by regular, if small, successions. At present this border will be our third; one lot is almost done, another is just coming in, and by the time they are mostly gone this border will be coming in, and be succeeded by small plants just turned out. Now, the border had carried a rather heavy mixed crop of Peas, Spinach, Lettuces, and Radishes. On clearing them off we never found a piece of ground so dry. On planting the Cauliflowers we made rather deep drills and soaked the plants in with sewage, and covered the surface with the dry soil. The leaves of these plants fell to the ground on the 22nd as if struck with paralysis. We could do nothing to help them, and we felt convinced they had that at their roots that would enable them to recover on the slightest change in the weather. By the 24th they showed they would bear the weather. The other day they looked tolerably well, so well, indeed, as to be admired by our friends,

and though they saw that every tank and reservoir was empty, they could not but hint that there must be some way of saturating them with water. We pulled our boot between the rows to the depth of 6 or 7 inches, to show how dry the soil was; with a stick we know we might have gone 6 inches deeper without finding a trace of moisture. What mere skiffing showers would ever wet such a depth of earth as dry as ashes? What would be the use of mere watering on the surface? The watering at the roots enabled the plants at once to grow, and once fairly set to work they would pump up moisture for themselves all the more easily because the already dry surface helped to keep the moisture about the roots. If the weather should continue dry, we shall most likely give a watering of sewage, which Cauliflowers can take pretty strong, but if possible, besides confining the water to the roots, we shall have a dry surface.

FRUIT GARDEN.

The chief work here has been shortening the summer shoots of bush, pyramidal, and wall trees, chiefly the lower parts of the trees, as the upper parts had been previously done. This balances the strength and vigour of the trees more than if such shortening and stopping had been done all at once.

Went over *Apricot* and *Peach* trees the second time, removing extra shoots, and spurring back, as the *Apricots* have grown freely again, especially after the watering with sewage. But for that, we are convinced a great portion of the fruit would have dropped, and several large branches would have given way. We are convinced that dryness at the roots is one chief cause why large branches of *Apricots* frequently die off without any apparent cause. When some of the *Apricot* fruit began to drop about six weeks ago, we were surprised to find the earth about the roots so very dry. On forking the surface, and making holes to let the water down, we were not at all afraid of strong sewage, knowing that it would be pretty well filtered and cleared before reaching the bulk of the roots. We would have mulched heavily the little space left between the walls and the crops on the border, in the case both of *Apricots* and *Peaches*, only we would thus keep out the sun heat, so favourable to root action and perfect ripening. Many of our wall trees we would wash if we could, if it were only to refresh the foliage, for insects have troubled us but little. In our orchard houses, though the fruit will be fair, the red spider is making its appearance, chiefly owing to our being unable to syringe. We must use more sulphur on the wall, &c., to prevent it spreading. The *Cherries* in orchard houses and on walls were never better. *Cherries* on standards out of doors were never more abundant, but they came small at first, and ripened very unequally—all in our favour, as we forget how many weeks we have gathered from them, and still on a short row of *May Dukes* there are a good many, and finer than the first, as the trees had each a small barrel of sewage, which told amazingly on the fruit. We hope it will do the same with *Morellos* on north walls, as, though plentiful, they were small when they began to colour. We should like to give them another watering. Even in their case the soil when examined was very dry, though receiving little direct sun.

With our scarcity of water, we are not so forward with *Strawberry plants* as we would wish to be. Took off some of the most forward runners layered in pots, layered more, and potted in 5-inch and 6-inch pots some of the most forward, using loamy soil moderately enriched, potting firmly, and shading a little from the bright sun for a few days, and to save frequent watering. As several times referred to, future success will chiefly depend on these simple points—keeping the bud of the plant slightly below the rim of the pot; fastening the young plant firmly in the pot, not merely using the fingers, but a blunt-ended wooden stick for the purpose; watering and shading a little at first, or syringing in bright sun, instead of shading, where water can be spared; and as soon as the roots are progressing freely, giving all the sunlight possible, whilst the pots stand on a hard bottom. As soon as the roots reach the sides of the pot, manure water may be given. The health and maturing of the plants before the end of autumn will be of more consequence than their luxuriance and size.

As to *drainage*, much more depends on the mode than on the quality and quantity of the drainage. In this case we do not like taking up room from the plant by a lot of drainage. Nevertheless, nothing spoils a good *Strawberry plant* in a pot sooner than the pot becoming waterlogged. We have often found a pot made so by the hole getting next to hermetically sealed, outside from the material on which the pot stood. The outside of the holes should, therefore, be examined at times. For saving room and keeping out worms, there is no plan better

than the following. Take a clean, dry pot, place one crock, a piece of a broken pot, say roughly from 1 to 1½ inch in diameter, over the hole in the bottom of the pot, but with its rounded or convex side downwards, so as to securely cover the hole. This will let water escape and keep out worms. Then lay a few more smaller pieces of broken pot round it—say three or four, though we are often satisfied with the one piece. On this or these lay a little clean, dry moss, which is the best, or a scattering of clean straw, chopped into from 1 to 2-inch lengths, which is the next best; over that a sprinkling of soot; and then, as a base, a handful of the roughest compost. Very little space may thus be taken up with drainage, and yet it will be thoroughly effectual. The water will pass quite freely enough, if the hole do not get clogged outside. Though we have used a little half-rotten dung and tree leaves to put over the drainage, the practice is not to be commended. Such material, besides being apt to become too close and unctuous, is also liable to have germs of fungi conveyed along with it, which are often difficult to get rid of. Simple modes are often the best. The moss is the best material for separating soil and drainage, and it has this advantage over chopped straw, or chopped clean litter, that it is in itself such an equaliser of moisture, parting with it freely when in excess, and retaining it to a certain extent when moisture is too limited.

ORNAMENTAL DEPARTMENT.

With many forebodings when we last wrote, we have reason on the whole to be thankful and satisfied. That dread Friday browned our beautiful *Coleus*, and though the points are acquiring their rich colour, a near inspection will show the leaves below somewhat browned. Rejoicing in the sunlight, as the *Coleus Verschaffeltii* does, it would appear that about 11° in the sun is as much as it can bear with impunity. Against the wall in the open air that day our thermometer rose to 117°. We could not say whether a good watering beneath would have helped much to neutralise the extreme heat and brightness of the sun. In a few days, if the weather be favourable, the young growth will conceal all the browned leaves, and until then we would wish the plants to be looked at from a distance instead of close at hand. The fine bed at *Woburn* had suffered on the same day, but you could only observe it when close to it on the 27th, and every trace will be gone in a few days. We have told several times before what that bed was bordered with in former years. This season the combination was the most beautiful we ever saw.

Iresine Herbstii, though a drinking plant, stood the ordeal of the heat and dryness extremely well. We noticed at *Tingrith* that *Iresine Berkeleyi*, in a prominent place, had been a little browned, but the brownness was gone before that Friday. We have not tried *Iresine Lindeni*, a kind with a narrow purple leaf, which we hope will be useful. *Herbstii* is very effective in a moist autumn; in such a summer as this the plants are apt to get rather lumpy, and the leaves round and large.

We have not lost more than half a dozen out of long lines of *Calceolarias*, which are a mass of bloom, and now we hope they will hold on, as even these drizzling rains in the morning have greatly helped them. The ground seems so dry that the roots must have gone down to a considerable depth. We come to this conclusion, for though in other cases we lost few plants, yet the bloom so flagged on small beds and where the plant was used chiefly as edgings, that we had to cut off more than we liked; but then in all such cases we could not stir the soil so deeply previous to planting as we could do in the case of these rows and in that of larger beds, which look now as if there had been no such week as that which terminated on the 23rd ult. Say what we will, and use the brightest-coloured yellow-leaved *Pelargoniums* as you will, and the most graceful and finest-foliaged *Marigolds*, none will make up for the want of the *Calceolaria* in flower beds. If Mr. Robson saw these just now after the severe ordeal through which they have passed, whilst advocating early planting, as he does so well, he would own there was also something to say on the other side.

Our *Hollyhocks* would please some people this season; the flowers are small, and the plants are dwarfs. Giving them any water was out of the question.

We had much to do in bringing up arrears of potting, and must think ere long of propagating for the flower beds next season.—R. F.

TRADE CATALOGUE RECEIVED.

Ant. Roozen, Florist, Overveen, near Haarlem, Holland.—*Catalogue of Hyacinths, Tulips, Crocus, Narcissus, and other Dutch and Cape Bulbs.*

TO CORRESPONDENTS.

•• We request that no one will write privately to any of the correspondents of the "Journal of Horticulture, Cottage Gardener, and Country Gentleman." By so doing they are subjected to unjustifiable trouble and expense. All communications should therefore be addressed *solely* to *The Editors of the Journal of Horticulture, &c., 171, Fleet Street, London, E.C.*

We also request that correspondents will not mix up on the same sheet questions relating to Gardening and those on Poultry and Bee subjects, if they expect to get them answered promptly and conveniently, but write them on separate communications. Also never to send more than two or three questions at once.

SECRETARY EXHIBITING (H. S. G.).—There is nothing illegal in his exhibiting, if there is no rule to the contrary.

TEMPERATURE (W. H. O.).—What was the greatest heat in England and in the East Indies in 1868? is a question too wide for us to answer. The greatest heat in the shade near London in July was 93°, and at Calcutta probably not 5° more in the hottest month; but there the differences in the temperature between hour and hour, and night and day, are but small compared to what they are in this country.

PELAGONIUMS (Veritas).—The box was smashed, and all the petals were intermixed. They appeared to belong to some of the French kinds.

TRICOLOR, BICOLOR, AND DISCOLOR (R. G.).—Tricolor means three-coloured, bicolor and discolor two-coloured, and four-coloured would be quadricolor. Your friend is right in saying that bicolor and discolor mean the same number of colours, but wrong as to the number.

PETRIFIED FIG (C. Pocock).—We believe it to be a fossil Echinus or zoophyte; we cannot decide as to the species unless we see the specimen. A similar one is engraved in some of the books on British fossils, but we forget which.

LAPAGERIA ROSEA CULTURE (Subscriber).—This plant is not difficult to cultivate either in a pot or border. In pot culture the plant should have a rather large pot. Good plants can be grown in 11-inch or 13-inch pots, the shoots being trained to a trellis, a flat one being most suitable. Whether grown in a border or pot, good drainage should be secured. A border 4 feet long, 2 feet wide, and 2 feet deep, clear of the drainage, will support a large plant. The drainage should be, as already stated, very good, for, during the season of growth, the watering must be plentiful, and at no time must the soil be allowed to become dry. At that time a plant in a pot will require a gallon daily, and one in a border thrice the quantity. When the growth and flowering are over, less water will, of course, be required. The soil most suitable is fibrous brown peat, free of sticks, torn in pieces, but used rough without any admixture. If the peat is deficient in sand, the latter should be liberally added. A light airy position in an ordinary greenhouse will suit it, but it must be shaded from direct sun. The shade must not be produced by climbers. The north side of a span-roofed house, or the east or west end of a house, will answer well, though almost any position will do if not dark nor exposed to the midday sun. It is impatient of having its roots disturbed, and should only be interfered with when at rest, and then so as not to injure the roots.

BUDDING ROSES ON THE MANETTI STOCK (Constant Reader).—The buds should be put in quite close to the ground, or as near that as practicable, so that when the plants are placed in their final position the union of the stock and bud may be covered with soil. The buds take quite as freely on the Manetti as on the Briar stock, and there is this advantage—that the operation can be performed as late as September. Budded plants are of much freer growth than grafted plants; and whilst budding may be done in the open air, a close frame or house and bottom heat are necessary for grafting.

VINES ON THE BACK WALL OF A VINERY (Ignoramus).—The Vines on the roof will shade the back wall too much for successful Grape culture. Having failed with Figs, it is not likely you can grow Vines, as Figs will succeed on the back wall of a vinery where the Vines are not closer together than 3 feet or 3 feet 6 inches. On the back wall, Vines do not require different treatment from those on the rafters. We think it unsuitable.

DRIVING WORMS OUT OF POTS (J. W. M.).—The lime water is made by pouring twenty gallons of water on 10 lbs. lime, stirring well up, and allowing the lime water to stand forty-eight hours, then watering the plants with the clear water, having previously stopped the holes in the pots. Give water enough to stand on the surface. In about three hours the obstruction to the drainage should be removed. The worms will by that time have come out of the pots or been destroyed. It is stated that a solution of 2 ozs. of soda to a gallon of water will destroy them and benefit the plants, but we have not tried it.

TOBACCO AND BITTER ALOES FOR DESTROYING APHIS (Idem).—Tobacco water and bitter aloes have for some time been used successfully for destroying aphides on Roses and other out-door plants, but the tobacco water is sufficient, and the aloes a superfluity. Four ounces of tobacco to two gallons of boiling water allowed to stand until cool, and then strained, will destroy all kinds of aphides.

PRUNING CRASSULAS, CACTUSES, AND CLERODENDRON BALFOURIANUM (H. S. B.).—We should cut back each Crassula shoot that has flowered to within an inch or two of its base, leaving the others entire, for those not flowering this year you will need to retain for next season's bloom. Those cut back now will produce flowering shoots in the second year. Old plants, from their size, are preferable to young plants, but why not have both? The Cactuses may also be cut down, but we should confine ourselves to cutting-out the old parts, leaving as much of the young fresh growth as possible. It will not hinder their flowering next season. Straggling shoots of the Clerodendron ought also to be cut-in now, but we should reserve the general pruning until spring, well thinned-out the growths in February, previous to fresh potting and starting into growth. It is best trained on a trellis; you may indulge your taste as to

the form. The shoots ought to be kept rather thin, but let them cover every part at from 3 to 4 inches apart. On a roof trellis the shoots ought to be kept about 6 inches apart, and at about 9 inches from the glass.

WYON ELM (W. N. M.).—We think it is simply honeydew, which is a great attraction to the wasps and small humble bees. The leaves turning yellow is frequently a consequence of their pores being closed by the honeydew, and the drought we have recently experienced has also, no doubt, exerted an influence. We do not think you can do anything to the tree. A good rain will, no doubt, set all right again. The wasps and bees do not injure the tree.

ORCHARD HOUSES (Noris).—There have been no subsequent articles by the same gentleman, but it is probable he may favour us with others when time permits. You can have Peavson's little volume, "The Orchard House," free by post from our office if you enclose nineteen postage stamps with your address.

PEACHES FALLING (C. S.).—Your Peaches are ripe, but badly coloured. We think you have left too many on the trees, and that that is the cause of their falling by hundreds.

PEACH LEAVES (G. W.).—The leaves of your trees are scalded through water resting upon them, and a deficiency of ventilation early in the morning when the sun has been so bright and fierce.

EARLY PEACH, PLUM, AND CHERRY (Subscriber).—The earliest Plum is Rivers's Prolific. We would, however, recommend you as a single variety, Jefferson; of Peaches, Early York or Royal George; of Cherries, Black Circassian. Cherries require a considerable amount of air to set their flowers; we do not think you would be very successful with them on a back wall; Plums would do better.

DOUBLE-BLOSSOMED PEACH FRUITING (N. H., Southampton).—It is not at all an unusual occurrence for the double-blossomed Peach to fruit abundantly, and in fine warm autumns the fruit ripens perfectly, but is not of good quality, being rather astringent. It is utterly unworthy of being grown as a fruit. It would, no doubt, during this intense heat be beneficial to give the tree a good soaking.

FUCHSIAS AT EXHIBITIONS (R. S. T.).—The prize having been offered for "six Fuchsias, distinct varieties," and no restriction being given, any variety was admissible, whatever its character. Fuchsia gracilis variegata is no more hardy than many others. It is used for bedding solely on account of its beautiful foliage. The judges could not disqualify.

KEEPING RIPE PEACHES (Idem).—Keep them in the coolest place you can find.

SOFT SOAP (G. C.).—If you refer to page 23, you will see that 2*l.* per lb. was a mistake. We believe you can obtain it wholesale for 3*d.* per lb., or even less. A wholesale dealer would supply you at a less rate than you are paying, if you ordered a quantity. We cannot recommend dealers.

MELONS DECAYING (P. E. C.).—It is difficult to state the cause of Melons decaying before they are ripe. We should attribute it to want of heat, but it may be caused by too much moisture. When Melons are ripening they require but little moisture, and should be kept dry and have plenty of heat and air. Without particulars of the cultivation afforded the plants, it is difficult to state the cause of failure. We could not say where the fault lay without further particulars.

PRIMULA CORTUSOIDES AMENA (J. S. B.).—It is hardy, but if the situation is cold and wet it should be wintered in a cold frame. A compost of two parts light fibrous loam, one part leaf soil, and one part sandy peat, with a sixth of silver sand, will grow it well. Good drainage is necessary. The plant should have an abundant supply of water when growing, and even when at rest the soil should be kept moist. After April it will do best in the open ground in a position shaded from the midday sun. We have no doubt that your plant will flower next spring if taken up carefully in autumn, potted, and wintered in a cold frame with plenty of air. If the situation is well drained we should leave it undisturbed, putting round it a light mulching of leaf soil or cocoa-nut fibre refuse. It flowers in April and May, and is very beautiful.

BLACK CHERRANTS (James Carter & Co.).—The Black Currant of which you sent branches appears to be a profuse bearer, but the berries are not so large as those of Black Naples; they hang firmly on their stalks, which is a great recommendation, and their flavour is good.

CAMELLIA LEAVES FALLING (J. T. S.).—It is not likely that the shading could have anything to do with the scorching of the leaves; and we do not think they are scorched, but that there has been a great deficiency of root action, the roots not supplying nutriment for the full development of the leaves, and when this is the case it is not unusual for the leaves and even young shoots to turn black and decay or fall. The only remedy is to repot at once in turf cut from a pasture of light loam, taking off the turf about an inch thick, tearing it to pieces with the hand, using it rough, and pressing the soil firm. Remove as much of the old soil as you can without injuring the roots. Water freely.

BEECHWOOD MELON (T. S.).—The old true Beechwood is very scarce. Not one out of a hundred cultivators has the true stock. The Beechwood, as we see it at the present day, is a long elliptical fruit, ribbed, very often deeply, seldom or never netted, thin in flesh, not melting but tough, insipid in flavour, and not often exceeding 2 lbs. in weight. The true Beechwood is in form more spherical than elliptical, and flattened at the ends like an orange, very slightly ribbed, and beautifully netted; flesh thick, melting, and finely flavoured. Under good cultivation it usually attains a weight of 4 lbs., often much more. We cannot recommend one seedsman in preference to another, such a course would be unfair.

INSECTS (B. Maries).—Your Rose leaves have been disfigured by the leaf-cutter bee, *Megachile centurialis*, which has been very abundant this season. (*E. P., jun.*)—The Elm trees on the Parade and in the People's Park, at St. Helier, Jersey, are infested with the Scolytus destructor, which lays its eggs in the bark of the trees, the young grubs burrowing off the central burrow, made by the female, at right angles, and so cutting through the sap vessels and in time destroying the trees. Such is our opinion at least, and that of many other naturalists; but another opinion is also current, that the trees are never attacked by the insects until they are in a state of disease from want of drainage, or want of water, or bad soil, &c. In France, as well as in the Regent's Park, London, some benefit has been obtained by partial disbarking the trees whilst young, taking care to burn the bark. It would also be serviceable if the trees were

surrounded with tarred haybands at the time that the perfect insects are making their appearance.—I. O. W.

POULTRY, BEE, AND PIGEON CHRONICLE.

EARLY EGGS FOR HATCHING.

It need hardly be pointed out that to the breeder of fancy poultry it is of very great importance to obtain eggs from his best hens early in the year, whether for sale or for his own use. I say from his best hens, because eggs from pullets are, of course, to be had easily in any quantity, but are by no means so good for early broods, producing chicks with less stamina, which fledge more slowly, and are altogether less adapted to withstand the vicissitudes of the early months. It is, therefore, to the early laying of the mature hens I purpose to devote this paper, the present being the time which my own experience leads me to believe has much influence upon the matter.

It has been said over and over again that early eggs cannot be obtained except from pullets, and also that there are no artificial means by which the production of eggs can be either hastened or retarded, being a natural process incapable of being interfered with. Both statements are generally true, but they are only true relatively, and any intelligent breeder who knows definitely what his object is, has very great power over the degree in which it shall be attained. If he wants, for instance, merely the greatest possible number of eggs in a year, his treatment will not be that I am now considering. But the fancy breeder does not so much seek a high average as to have eggs in good time. He knows that every egg early in the year may produce a valuable fowl, or will be saleable at a high price, whilst later on it will only realise its mere food value; so that twenty eggs in August may be of less account than one in February. It is on this principle he must proceed.

All my observations during several seasons have satisfied me that the time at which a bird begins laying depends chiefly, after allowing for differences of breed and character, upon the time when she left off. If a Cochin hen has been laying very late in the autumn, almost, in fact, into the winter, it is absurd to expect she can begin again till the season is well advanced. Cochins and Brahmans, and even Hamburgs, will, in fact, often lay till more than half through a severe moult, which is, of course, a drain upon the system so extensive as to demand much time for recovery. But, on the other hand, if a hen has had a late brood of chickens, it will almost always be found that she lays in good time, and for several years I have found no difficulty in getting eggs from a portion at least of my hens by Christmas, or even before.

As the hens become broody towards the end of July and August, therefore, let them either be allowed to sit, or if that be inconvenient, to remain on the nest for a month or five weeks. This will not only give the system a rest, but it actually induces or hastens the moult, the feathers dropping off very frequently almost in handfuls. The process will generally be half through, in fact, by the time the bird is turned off, and she will then rarely lay again till after it is completed; whereas, if the moult finds a hen laying, she will often, as I have said, continue till nearly through. A little meat and ale will also help to hasten the process, and plenty of fresh green food must also be supplied. Under these conditions, and not being reduced by egg-laying, the moulting will be hastened very considerably, and the bird will be in laying condition much sooner than if turned off her nest directly she is broody for the sake of her autumn eggs, as is generally done.

Of course some breeds are less prolific than others, and it is much more difficult to get early eggs from a Dorking than a Cochin; but in all cases much may be done by such a system of management in the case of breeds which evince a regular desire for incubation. There are, of course, several minor matters to observe, such as the selection of birds hatched in good time, and which will, therefore, moult tolerably early; the providing tight and well-sheltered houses, &c.; but the securing the cessation of eggs for some little time before the moult, and the hastening of that process, have by far the greatest influence on the matter, so far as my observations go.

There is one more point to be mentioned. Though the mating will not, I think, hasten laying in the least, I have generally found that even hens which left off early in the autumn did not lay till three weeks or a month after enjoying the company of the cock, and not then unless he also were in good condition. The hens should therefore be mated by the

end of November, and for early eggs only cocks penned up, which have moulted well and regained perfect health and vigour.—L. WRIGHT.

WATCHING THE CHICKENS.

By some people, but not, certainly, by readers of "our Journal," watching the chickens would at once be set down as an amusement suited to the buttercup-and-daisy-gathering age. Be it so; sensation novels, railway running about, and the like, have unsettled many minds, and made people enjoy less, or unfitted them to enjoy at all, pleasures found at home. But yet a taste for simple enjoyments is a healthy taste, and one which never tires. Still, tastes will differ to the end. "I cannot understand," said a young lady to me, "whatever there is for you to make a fuss about, week after week, in that gardening and poultry paper of yours." I replied "I cannot think why you are so particular to have the newspaper the first day that it contains the month's fashions."

Well, tastes will differ. Thus some people cannot even see a joke. A man with a keen sense of humour was looking through a gallery of pictures with a friend who had no more sense of humour than an iron bar. Presently they came to a picture of two cats fighting. "Ah," said the quick-witted one, "evidently by Claude (clawed)." "Indeed, it is not," replied the matter-of-fact man, "I assure you that Claude painted only landscapes, of which I have seen many," &c. Not even Sidney Smith's remedy for a dull man—viz., to have a surgical operation performed upon his skull, in order to get a joke in, would suffice for such a one. Yet dullness is at times amusing, as "Did 'em wear tin gaiters then?" said an old farmer who was looking at a brass in a church. But I am conscious that I am rambling, roaming far away from my subject.

To return. During this hot weather, now reaching over many weeks, when I was afraid to be in the sun, lest, as somebody said, "a small heap of bones and a grease spot should be found instead of one's self"—sitting, then, in the shade of a far-reaching elm that throws its shadow on some part or other of a greensward the summer day long, I was day after day reading, but—I could not help it—"from my sleek hand dropped" very often not "the gathered rose," as Rogers describes the child who had fallen asleep, but dropped my book to my knee while I watched the chickens. Perhaps they this year were even more attractive than usual, being groups of tiny Bantam chicks—little neat-formed "sprack" (sprack is good Wiltshire, though not good English) Game Bantam chickens from eggs of Mr. Crosland's. Let me prattle—a child-like word becomes a child-like pleasure, as some one, not a reader of "our Journal," but one who has taken it up by mistake, would say—let me prattle, then, about these times. How tiny, indeed, they are when from the little eggs they first come, seeming too small to get on their feet; but soon they do, and totter about an inch or two, and then make a tumbling plunge under the feathery care of all warmth and comfort beneath the hen. Then follow the first pickings and sippings, trying the appetite with that as yet unknown thing—food. But how rapid is the progress of chickens well cared for—that is, understandingly cared for. The warm south-fronted outhouse first receives them, and next day they venture upon little, still tottering walks, and one bolder or stronger than the rest even circumambulates the coop, and feels as he felt who first sailed round the world. The following day they are on the lawn, shaded duly from midday sun, and then note their progress. Little aerial fly-catchings are attempted, and wanderings and scratchings with feeble feet, and the first worm found and run away with, the fortunate or unfortunate chick (for he usually loses it) duly chased by the rest, eager to become worm-devourers. Then some one or other of the brood strays into some laurel bush, and, like the babes in the wood, is lost, and shrilly yelps forth his sorrow to the sore discomfiture of the listening but not seeing hen. But head grows with body; soon they know their feeder and his wonted call, and run to meet him with expanded wings assisting their legs, for they soon become things with wings, each week the useless winglets growing more and more into useful wings.

When the first month is turned, as I notice in my little Game Bantam chicks, the little pullets have their golden hackles coming, seen as they run from me, and resembling tags of gold thread hung to the back of their necks. Then the little cockerels are developing, for here and there a black or red feather is appearing, and a cock-pheasant-like hue is visible in their plumage. In watching a couple of broods of Game Ban-

tams of a similar age it is interesting to notice the slight variations in colour, and how gradually the owner comes to mark with the eye and know individuals, as an eastern shepherd gets to know his flock, though a stranger would think all pretty nearly alike. Adult-like and yet not adult feathers come on; and the little sinewy legs, ludicrous miniatures of Game fowls' legs, are to be noticed; and here and there the eye marks what will be the gems of the brood. Now, too, is the time of peace, when all are good boys and girls, and no fighting; it is the time, too, of affectionate clustering together in the sunshine, and posing in graceful attitudes, or having or shamming to have a dust bath in common. But lo! six weeks have turned, and the weather is warm, so away shall go the brood hens. The more independent lot show no signs of regret, but go to roost like old birds, struggling, however, for the inside places. These sturdy independents wander further than before and wherever they choose, and are evidently glad that mamma is gone with her unceasing and commanding cluckings and callings. The less independent give forth a chorus of miserable yelps on discovering that they are alone in the world; and at bedtime, after a few manly attempts at roosting, fearing, perhaps, that they should fall off, they huddle together in the corner of a manger, and fancy they are brooded as formerly.

Thus I have noted down my "watching the chickens" from their first appearance in the world to their life of independence. I have noted all down, not in a very particular manner, or in a very orderly style, perhaps; but I am not such a particular man as he was who took me up sharply when I said, "Now I will put on my coat and waistcoat," saying, "That is incorrect, you mean you will put on your waistcoat and coat;" or a brother particularian, who laid much emphasis on the order of the words "I eat and drink," eating at dinner, and having a tumbler of water brought in an hour afterwards.

But particularians, avant! I have noted down in my own way and told how I have watched the chickens, an interesting pastime—one giving pleasure, and tending to make a man love still more his own home and feel how dear it is to him, and that, loving it, he does not need to rove away and rattle along the railway in search of happiness. The town man, and especially he of London town, needs a summer change. But where to? To woods, and fields, and country scenes, to relieve and comfort eye, and ear, and mind. But we in the country dwelling have all these comforts continually, and can well remain in the spring, summer, and autumn, not wishing for change. I speak of those who love and not merely endure the country. I speak of those who feel an interest in all around them—people, garden, and pets, in-door and out, and these enjoy their life and bless the Almighty for their lot and His good gifts. —WILTSHIRE RECTOR.

APPLETON-LE-STREET POULTRY SHOW.

The poultry show in connection with the Floral and Agricultural Society held at Appleton-le-Street, near Malton, last week, was a very creditable one, and proves what can be done by careful management and judicious arrangements to raise a small village show into an important district one. Most of the classes were well filled, and in some the competition was very close. The *Dorkings* were large and good, but some otherwise good birds lost all chance from imperfect feet. The *Brahmas* were very few in number. The Dark *Cochins* were good, but the *Buffs* very poor. The *Spanish* formed a very good class, and the winning pen, belonging to Mr. Holmes, of Driffield, carried off the silver medal for the best pen of poultry in the yard. The *Game*, also, were a good and numerous class. The *Hamburgh* class was well filled with some good birds. As all the varieties were shown together, it was difficult to decide on the merits of the different pens; we hope next year they will be divided into two if not four classes. The class for crossbred farmyard birds brought out some really good and useful specimens of the right sort. The little *Bantams*, chiefly *Game*, were as good and pretty as usual. Some of the *Geese* were very fine and large. *Rouen Ducks* were numerous, but sadly in the moult. *Aylesburies* were large, but few in number. Special prizes were given for young poultry for table purposes, which brought a good show of useful chickens and heavy ducklings, but the goslings were not so good.

WHITE COCHINS.—There are only two or three poultry shows where White Cochins are separately classed; this prevents many from exhibiting, and I think the committees only want reminding of this exclusion to remedy it.—F. R.

WARRINGTON POULTRY SHOW.—The date of the entries closing for this Show has been extended to August 8th, and we trust that this will be the means of bringing increased support

from exhibitors, especially as the Show, if successful, will be repeated on a larger scale next year. The amount of subscriptions already collected, exclusive of the town of Warrington, is £400, and the prizes are liberal.

THIRSK POULTRY SHOW.

The following prizes were awarded at the first Show of the Thirsk Agricultural Society, which took place on July 27th.

DORKINGS.—1, J. White, Northallerton. 2, W. Bearpark, Ainderby Steeple. **GAME**.—1, J. Watson, Knaresborough. 2, R. Akenhead, Otterington Hall. **SPANISH**.—1 and 2, W. Bearpark. **COCHIN-CHINA**.—*Buff*.—1, R. E. Brown, Osvaldikirk. 2, W. & F. Pickard, Leeds. *Partridge*.—1, W. Barnes, Thirsk. 2, W. J. Stewart, Darlington. **BRAMA POULTRY**.—1, F. Horseman, Borough-bridge. 2, J. Bell, Thirsk. **HAMBURGH**.—*Golden-spangled*.—1, Mrs. Plummer, Eastergate. 2, W. Bearpark. *Silver-spangled*.—1, J. Best, Borough-bridge. 2, W. Manfield, Thirsk. **GOLDEN-PENCILED**.—1 and 2, W. Bearpark. *Silver-penciled*.—1, W. H. Atkinson, Thirsk. 2, W. Bearpark. **BANTAMS**.—*Black*.—1, G. Atkinson, Croft. 2, J. Watson, Knaresborough. *Game*.—1, R. J. Stewart, 2, E. Barker, Stokesley. *Any other Variety*.—1, G. Robinson, Thirsk. 2, T. Tweedy, Thirsk. **DUCKS**.—*Rouen*.—1, C. Graham. 2, G. Smith, York. *Aylesbury*.—1, G. Smith. *Any other Variety*.—1, R. Wilson, Thirsk. 2, M. Fairy, Thirsk. **TURKEYS**.—1, Rev. G. Hustler, Sulhulphed, York. 2, J. Arrowsmith, South Kildington, Thirsk. **GEESE**.—1, Rev. G. Hindle. 2, J. B. Braithwaite, Northallerton. **GUINEA FOWLS**.—1 and 2, R. Wright. **SELLING CLASS**.—1, W. R. West, Sowerby Grange, Thirsk. 2, G. Calvert, Darlington. **ANY OTHER VARIETY**.—1, C. Walker, Borough-bridge. 2, T. Barnett, Bishorth. **CHICKENS**.—(Ten of four).—1, J. White, Warley, Northallerton.

PIGEONS.

CARRIERS.—1, G. Sadler, Borough-bridge. **TUMBLERS**.—*Red-wood*.—1, C. Anton, York. *Any Variety*.—1, C. Anton. **POUTERS**.—1, W. Bearpark. **JACOBIANS**.—1, R. Wilson, Thirsk. **FANTAILS**.—1, W. FISHER, THIRSK. **TOUMPTERS**.—1, C. Anton. **OWLS**.—1, W. Bearpark. **NEWS**.—1, W. EATPARK, THIRSK. —1, R. Wilson. **TURBANS**.—1, R. Wilson. **DRAGONS**.—1, J. Cludate, East Howick, Ripon. **ARCHANGELS**.—1, R. Wilson. **ANY OTHER VARIETY**.—1, W. Bearpark.

JUDGES.—*Poultry*: Mr. Barker, York. *Pigeons*: Mr. E. Wilson, York.

PRESTON POULTRY SHOW.

The first Show of the Preston Agricultural Society was held July 27th and 28th. The weather was very fine, the ground in all respects suitable, and being very easy of access the Show was well attended. The extent of the show-ground was seventeen acres, and the whole was well filled.

The poultry was not numerous, taking into account the liberal prizes offered, the number of pens being a little under two hundred, but, as a whole, the quality was very good. The *Dorkings* were in poor condition. The single *Spanish* cocks were mostly in deep moult, but the prize birds were good. The *Game* classes contained some good pens, but many of them were much out of condition. The *Hamburghs* were not numerous, but the birds were good. The *French* fowls were very good, and the *Brahmas* were the best class in the Show. The *Rouen Ducks* were good, but the entries were small in all the *Duck* classes.

DORKINGS.—1, Gunson & Jefferson, Whitehaven. 2, J. Robinson, Garstang. *hc*, Hon. H. W. Fitzwilliam, Wentworth Woodhouse, Rotherham. **FRENCH FOWLS**.—1, H. Beldon, Gaitstock, Bingley. 2 and *hc*, Hon. W. H. Fitzwilliam. **BRAMA POULTRY**.—1, J. H. Pickles, Birkdale, Southport. 2, H. Lacy, Hebburn Bridge. *hc*, F. H. Green, Bertelvoelze, Windsor, Belfast. 3, J. H. Pickles, W. GARDON, CHESTER. **SPANISH**.—1, F. & C. Haworth, Haslingden. 2, C. W. Brierley, Middleton. *hc*, H. Wilkinson, Farby; F. & C. Haworth; J. Leeming, Broughton, Preston. **GAME** (any colour).—1 and 2, C. W. Brierley. *hc*, B. Bee, Goosnargh (Black-breasted Red); T. Waring, Preston (Black Red). **COCHIN-CHINA**.—1, T. Stretch, Ormskirk. 2, J. H. Dawes, Birmingham (Buff). **HAMBURGH**.—*Golden-penciled*.—1, H. Pickles, jun., Erby. 2, H. Beldon. *Silver-penciled*.—1, H. Pickles, jun. 2, H. Beldon. *Golden-spangled*.—1, H. Beldon. 2, H. Pickles, jun. *Silver-spangled*.—1, H. Beldon. 2, H. Pickles, jun. *hc*, F. Fielding, Newchurch, Rossendale. **GESE**.—1, H. Beldon. 2, H. Pickles, jun. *hc*, F. E. Eutwick, Checkheaton, Leeds. 2, J. Oldford, Wakefield. **BANTAMS** (any colour).—1, S. & R. Ashton, Roe Cross, Mottram. 2, H. Beldon. *hc*, J. Walker, Halifax (Black). **GEESE**.—1, E. Leech, Rossendale. 2, S. H. Stott, Rossdale. *hc*, W. H. Butcher, Preston. **DUCKS**.—*Aylesbury*.—1, E. Leech. 2, S. H. Stott. *Rouen*.—1, E. Leech. 2, T. Wakefield. *hc*, H. B. Smith, Broughton; S. H. Stott; T. Waring, Preston. **ORNAMENTAL WATERFOWL**.—1, C. W. Brierley. 2, H. B. Smith (Shield Ducks). **TURKEYS**.—1, E. Leech. 2, L. Anyon, White-le- Woods, Chorley.

SINGLE COCKS.

DORKING.—1, J. Robinson. 2, Hon. H. W. Fitzwilliam. **SPANISH**.—1, H. Beldon. 2, J. Leeming. *hc*, W. G. Mulligan, Springhead, Belfast. **GAME**.—1 and 2, C. W. Brierley. **GAME BANTAM** (any colour).—1, Harwood & Buckley, Accrington (Black Red). 2, Bellingham & Gill, Burnley.

PIGEONS.

CARRIERS.—1 and 2, T. Pincock, Preston (Dun and Black). **TUMBLERS**.—1, J. Hawley, Bingley. **BARBS**.—1, T. Pincock (Black). 2, H. Yardley, Birmingham. **OWLS**.—1, J. Hawley. **POUTERS** or **CHIFFERS**.—1, J. Hawley. **FANTAILS**.—1, H. Yardley. 2, J. Kemp, Haslingden. **TURBANS**.—1, J. Kemp. 2, H. Yardley. **DRAGONS**.—1, H. Oakley, Preston (Blue). 2, H. Yardley. **TOUMPTERS**.—1 and *hc*, J. Hawley. 2, J. Turner, Broughton (White). **JACOBIANS**.—1, J. Hawley. **NEWS**.—1 and 2, H. Yardley. **ANTWERPS**.—1, J. Oldford. 2, W. H. Mitchell. **ANY OTHER VARIETY**.—1, H. Yardley. 2, J. Hawley.

JUDGES.—Mr. R. Teebay, Fulwood, Preston, and Mr. J. Dixon, North Park, Bradford.

CROYDON POULTRY SHOW.

This Show, held in connection with that of the East Surrey Agricultural Association, took place July 27th. The arrangements reflected great credit on the Secretary, Mr. W. H. Rowland. Mr. Billett, of Southampton, supplied his pens, which are roomy and convenient, and, which is of great importance, they are of such a height as to prevent the largest birds injuring themselves against the tops.

The best classes were *Dorkings*, *Spanish*, and *Hamburghs*. The first and second prize pens of *Game Bantams* were very good. Of the larger *Game* fowls there was a very poor show, there being scarcely a pen

worthy of the name. Aylesbury and Rouen Ducks were good, but the "Variety class" very indifferent. Only one pen of Turkeys was entered. Geese were more numerous, but the quality was indifferent, and we noticed but little attention had been paid to matching the birds.

DOBRINGS.—1, C. Havers, Ingatstone. 2, Ivory & Son, Dorking. SPANISH.—1, P. James, Peckham Rye. 2, Rev. J. Randolph, Tottenham. RED BREASTED.—1 and 2, W. Irving, Faversham (Creve-Coeurs and Hondans). 3, Rev. N. G. Ridley, Newbury (Malay). *hc*, J. Pares, Postford, Guildford (Japanese Silkies). GAME.—1, E. C. Good, Carshalton. 2, C. Purrott, Croydon. HAMBURGS.—1, Miss C. E. Palmer, Lighthouse, Warwick (Golden-spangled). 2, C. Havers (Golden-pencilled). *hc*, T. Penfold, Newhaven (Golden-spangled). COCHINS and BIANTAMS.—1, J. Pares (Light Brahma). BANTAMS.—1, T. R. Edridge, Croydon (Black-Red Game). 2, G. H. Gillham, New Cross Road, London (Game). *hc*, H. Nalder, Croydon (Black-Red Game). 3, Rev. A. H. Bridges, Redington House, T. P. Keen, Croydon (Duckwing Game). TURKEYS.—1, Rev. N. J. Ridley (Cambridge). GESE.—1, W. Oakley, Oxted (Grey). 2, E. Byron, Condon Court. *c*, J. Pares (Sehatopol); C. Pnrrott, Goslings.—1, W. Oakley. 2, E. Byron. *hc*, T. Chandler, Purley Oaks. DECKS.—Aylesbury.—1, 2, and Extra, W. Oakley (Ducklings). Rouen.—1, W. Oakley. 2, J. Ivory & Son. ANY OTHER VARIETY.—1, 2, and Extra, J. W. Sutherland (Sheldrake and Wild Ducks).

The Judges were Mr. Elgar, Red Hill, Surrey, and Mr. G. S. Sainsbury, Devizes.

SLEAFORD POULTRY SHOW.

THE second Exhibition of the Lincolnshire Agricultural Society was held at Sleaford on the 27th, 28th, and 29th of July. The show of poultry and Pigeons consisted of upwards of 150 pens.

DOBRINGS.—1, G. Andrews, Tuxford. 2, R. Wood, Clapton, Thrapstone. 3, J. Hornsby, Grantham. *hc*, T. F. A. Burnaby, Newark. 4, W. Dudding, Howell, Sleaford. COCHINS (Any variety).—1 and Sir T. Whitehead's prize, M. A. Sauray, Radcliffe-on-Trent (Buff). 2, H. H. Rolston, Banwell, Oundle (White). 3, J. K. Fowler, Aylesbury (Partridge). *c*, J. H. Dawes, Birmingham (Buff). BRAHMS.—1, C. Chaloner, Whitwell, Chesterfield. 2, J. Elgar, Newark. 3, C. Layland, Morris Brook, Warrington (Dark). POLANDS.—1, W. R. Patrick, West Wiche, Lynn. 2, J. P. Mansell, Lincoln. FRENCH.—1, Mrs. J. Cross, Brigg (Creve-Coeur). 2, G. Andrews, 3, G. S. Harvey, Dorrington, Sleaford (Hondans). *hc*, W. O. Quibel, Newark (Hondans). *c*, J. Elgar (Hondans). 1, J. Manton, Englishwode (Cr. or Buff). Mrs. F. Cross (Hondans). W. O. Quibel (Hondans); J. K. Fowler (Game). ANY VARIETY.—1 and Sir T. Whitehead's prize, C. Chaloner, Chesterfield. 2, J. Laming, Cowburn, Spaulding. 3, F. Tomblin, Thorpe Latimer, Sleaford (Black-breasted Reds). SPANISH.—1, T. C. & E. Newbitt, Epworth. 2 and 3 Withheld. HAMBURGS (Any variety).—1, J. F. Lovingside, Newark (Golden-spangled). 2, C. Edwards, Holbeach (Golden-pencilled). BANTAMS.—*Game*, any variety.—1, C. Chaloner. 2, J. G. Lyall, Middle Basson (Black-breasted). ANY OTHER VARIETY.—1, T. C. & E. Newbitt (Black). 2, Hon. and Rev. F. B. M. M. Black. ANY VARIETY.—1, C. Chaloner. 2, J. Laming (Game). 3, T. F. A. Burnaby (Dorking). GESE.—1, E. Leech, Rochdale. 2, J. K. Fowler, 3, Withheld. DUCKS.—Aylesbury.—1 and 2, J. K. Fowler. 3, J. Hornsby, Grantham. Rouen.—1, E. Leech. 2, W. Dudding, Howell, Sleaford. 3, K. Wood. ANY OTHER VARIETY.—1 and *hc*, W. Dudding (Buenos Ayres). 2, S. & K. Ashton, Mottam (Gargant). 3, J. K. Fowler (Carolina). TURKEYS.—1 and extra prize, E. Leech. 2, M. Kew (Cambridge). GENEA FOWLS.—1, T. C. & E. Newbitt. 2, Mrs. G. Burton, Barrow-on-Union. SELLING CLASS.—1, T. C. & E. Newbitt. 2, C. Chaloner (Game). 3, J. Hornsby, Castle Gate House, Grantham.

PIGEONS.—Carriers.—1, H. Yardley, Birmingham. 2, J. Elgar. Pouters.—1, H. Yardley. 2, J. F. Farlow, Peterborough. Tumblers.—1, H. Yardley. 2, J. Elgar. ANY OTHER VARIETY.—1 and *c*, J. Elgar (Black Barbs). 2, H. Yardley.

JUDGE.—Mr. W. B. Tegetmeier.

HESSE POULTRY SHOW.

THIS Exhibition took place at Hesse, near Hull, on the 27th ult. The number of entries was considerably less than last year, but the general quality of the birds was much superior; some excellent specimens were shown in the Game, Hamburgish, Polish, and Bantam classes. In the Pigeon department the competition was very close, the Dragon, Carrier, Trumpeter, and "Any variety" classes were the best; in the latter White Owls took both prizes.

SPANISH.—1, G. Holmes, Driffield. 2.—Lawson, Hull. COCK.—1, G. Holmes. DOBRINGS.—1, G. Holmes. 2, J. Thompson. COCK.—1, G. Liveridge, Cottingham. COCHIN-CHINA.—1, H. Lawson. COCK.—1, G. Liveridge. GAME.—Black-breasted or other Reds.—1, H. M. Julian. 2, G. Holmes. COCK.—1, H. M. Julian. ANY OTHER VARIETY.—1, H. M. Julian. POLANDS.—1 and 2, Mrs. Proctor, COCK.—1, Mrs. Proctor. HAMBURGS.—Golden-spangled.—1, G. Holmes. COCK.—1, G. Holmes. Gold-pencilled.—1, G. Holmes. 2, G. Purdon, Driffield. D. White, Driffield. Silver-spangled.—1, G. Holmes. 2.—Willerton, Hesse. COCK.—1.—Willerton. Silver-pencilled.—1, G. Holmes. 2, R. Robson Beetonville. COCK.—1, G. Holmes. BANTAMS.—Game.—1, J. Dugdale, Driffield. 2, W. Adams, Ipswich. COCK.—1, J. Dugdale. ANY OTHER VARIETY.—1, T. C. Harrison, Hull. 2, Miss E. Harrison, Hull. 3, G. Hurry, Hull. ANY OTHER VARIETY.—1, G. L. H. Beverley. 2, R. Loft, Woodmansay. SELLING CLASS.—1.—Purdon. 2, W. Hardy, Hesse. DUCKS.—Aylesbury.—1, D. Merkin, Driffield. 2, O. A. Young, Driffield. Rouen.—1, D. Merkin. 2, O. A. Young. Common.—1, O. A. Young.

PIGEONS.

DRAGONS.—1, W. H. Adams, Beverley. 2, H. Lawson. POTTERS.—1, P. Hague, Hull. 2, T. Statters, Hull. CARRIERS.—1, W. Canupey, Beverley. 2, T. Thompson, Hull. TRUMPETERS.—1, T. Statters. 2, C. Lythe, Cottingham. JACOBS.—1, C. Lythe. 2, G. C. Davis, Hull. FANTAILS.—1, H. Adams. 2, H. Lawson. TUMBLERS.—1, H. Adams. 2, C. Lythe. BARBS.—1, T. Statters. 2, T. Thompson. NENKS.—1, C. Lythe. 2, H. Adams. ANY OTHER VARIETY.—1, Mrs. Proctor. 2, H. Adams.

RABBITS.—Lops and L.—1, J. White, Hull. 2, Miss Fletcher. ANY VARIETY.—1, P. Ashton, Hull. 2, J. Lunn. Heaviest.—1, J. Fletcher.

JUDGES.—Mr. J. Hodgkinson, and Mr. D. Pickering, Hull.

CLECKHEATON POULTRY SHOW.

THIS was held on the 30th ult., when the following prizes were awarded by the Judges, Mr. James Dixon, of Bradford, and Mr. R. Teclay, of Fulwood, Preston:—

GAME.—Black or Brown Red.—1, E. Aykroyd, Eccleshill. 2, T. Bottomley, Shelf. *hc*, J. W. Thompson, Southwark. Duckwing, Blue or Green.—1, E. Aykroyd. 2, H. C. & W. J. Mason, Drighlington. ANY VARIETY.—1, H. C. & W.

J. Mason. 2, R. & H. Walker, Gomersal. DOBRINGS.—1, T. Briden, Early. 2, W. H. King, Rochdale. COCHIN-CHINA.—Cinnamon or Buff.—1, H. Beldon, Bingley. ANY VARIETY.—1, J. White, Netherton. 2, H. Beldon. SPANISH.—1, H. Beldon. 2, J. Powell, Bradford. BRAHMA POOTRA.—1, H. Leacy, Hebden Bridge. 2, E. Leech, Rochdale. *hc*, W. Whiteley, Sheffield. HAMBURGS.—Golden-pencilled.—1, H. Beldon. 2, S. Smith, Northwram. Duck.—1, H. Beldon. 2, H. W. Hilmworth, Idle. Golden-spangled.—1, H. Beldon. Silver-spangled.—1 and 2, H. Beldon. BANTAMS.—Game, Black or Red.—1 and *hc*, W. F. Entwistle, Cleckheaton. 2, G. Noble, Staincliffe. Game, any Variety.—1 and 2, W. F. Entwistle. ANY OTHER VARIETY.—1, J. Walker, Halifax. 2, H. Beldon. *hc*, S. Rhodes, Wike. ANY OTHER VARIETY.—1 and 2, H. Beldon. TURKEYS.—1, E. Leech. 2, W. Stocks, Cleckheaton. *hc*, S. E. England, Silsden. GESE (Any variety).—1, E. Leech. 2, J. White, Netherton. 3, H. Crossley, Halifax. DECKS.—Aylesbury.—1, E. Leech. Rouen.—1, E. Leech. 2, J. White. ANY OTHER VARIETY.—1, T. C. Harrison, Hull. 2, J. Woodcock, Cleckheaton.

PIGEONS.

TUMBLERS.—1, J. Hawley, Bingley. 2, H. Yardley, Birmingham. CARRIERS.—1, W. H. Mitchell, Moseley. 2, H. Yardley, *hc*, S. Smith, Idle. POTTERS OR CROPPERS.—1 and 2, J. Hawley. FANTAILS.—1, F. Graham, Birkenhead. 2, H. Yardley. DRAGONS.—1, W. H. Mitchell. 2, S. Smith. 3, T. Kaye, Hoxley, *hc*, H. Yardley. JACOBS.—1 and 2, J. Hawley. NENKS.—1, F. Graham. P. Birdwell, Astbury. 3, B. Peck, Birkshaw. 4, J. Oldroyd, *hc*, J. Hawley; C. Arton, York. ANY OTHER VARIETY.—1, C. Arton. 2, J. Hawley.

RABBITS.—Lops and L.—1, R. Thornton, Gomersal. 2, W. Crowther, Gomersal. ANY VARIETY.—1, K. Thornton. 2, J. Birky, Cleckheaton.

DRIFFIELD POULTRY SHOW.

THIS year's meeting of the Driffield Society was a most satisfactory one as regards both the receipts at the entrance gates and the number of pens exhibited. Many very excellent birds were shown in the deepest moult, which was a considerable drawback to the general effect. The poultry were placed entirely in the open air, but as the day was exceedingly fine no evil consequences ensued to delicate varieties. Game fowls throughout were exceedingly fine, but the Hamburgs, with the exception of very few pens, were most defective. Geese and Turkeys were first-rate, and the entry of fancy Ducks was a really good one; but the display of both Aylesbury and Rouen Ducks was so very limited that there was no competition for the second prizes. Pigeons in most instances were both good and attractive, and a few remarkably good Rabbits were shown.

DOBRINGS.—1, G. Holmes, Driffield. 2, W. Charter, Driffield. *hc*, R. W. Richardson, Beverley. Chickens.—1, R. W. Richardson. *hc*, W. English, Pickering. *c*, Miss Jordan, Eastburn; T. H. Trig. COCK.—1, J. A. Blanchard, 2, P. White, Driffield. SPANISH.—1, G. Holmes. 2, J. Williamson, Driffield. *hc*, W. Charter, T. H. Trig. 3, G. M. Maynard, Driffield. *hc*, G. Holmes, W. Charter. *c*, R. Stabler, Driffield; W. English, Gomersal. Black-breasted and other Reds.—1, H. Holmes. 2, W. Boyes, Beverley. *hc*, J. W. Lacey, Driffield (2); W. Boyes. COCK.—1, W. Boyes. *hc*, G. Holmes. ANY OTHER VARIETY.—1, 2, and Silver Medal for the best pen of poultry of any kind exhibited, W. Boyes. COCK.—1, W. Boyes. Chickens.—1, W. Boyes. *c*, F. Parkinson, Market Weighton; J. W. Lacey; W. English. COCHIN-CHINA.—1, E. Dawson, Beverley. 2, T. S. Turner, Barrobridge. *c*, G. Holmes. Chickens.—1, W. J. Purdon, Driffield. *hc*, W. Charter, T. H. Trig. 3, E. Dawson. POLANDS.—1 and 2, T. S. Turner. *c*, W. English. HAMBURGS.—Golden-spangled.—1, G. Holmes. 2, H. Holmes. *hc*, D. Maynard. COCK.—1, T. Holmes. *hc*, H. Holmes. Silver-spangled.—1, H. Holmes. 2, Withheld. COCK.—1, H. Holmes. Golden-pencilled.—1, H. Holmes. 2, W. J. Purdon. COCK.—1, D. Stabler. *hc*, E. Wilson, Norton, Malton. Silver-spangled.—1, T. Holmes. 2, R. Wilson. *c*, H. Holmes. COCK.—1, H. Holmes. ANY VARIETY.—1, H. Holmes. *hc*, O. A. Young, Parkyayn Cross.—1, H. Beckin, Driffield. 2, M. Berman, Driffield. *c*, O. A. Young. COCK.—1, G. Robinson, Frodingham. 2, H. Merkin. BANTAMS.—Game.—1, W. Adams, Ipswich. 2, A. Dugdale, Driffield. *hc*, W. Mecke, Driffield. *c*, J. Stabler; E. Hutchinson; T. Holmes; H. Smith, Peacably, Norton, Malton. COCK.—1, T. Holmes. *hc*, F. Pickering; E. Stabler; G. H. Pickering. ANY OTHER VARIETY.—1 and 2, T. C. Harrison, Hull (Black and Gold-faced). *hc*, T. Holmes (White). COCK.—1, T. C. Harrison. GESE.—1, O. A. Young. 2, G. Smitson, Driffield. BUSHES.—1, Mrs. W. Mosey, Skerne. 2, Mrs. Troff, Birkham. Turkeys.—1, P. C. Matthews, Birkham. 2, W. Charter, *hc*, G. M. A. Ulroft, Middleton Green. *c*, L. Danks, Great Back; Mrs. Drakton, Frodingham. GUSIA FOWLS.—1, O. A. Young, Driffield. DECKS.—Aylesbury.—1, O. A. Young. 2, no competition. Ducklings.—1, O. A. Young. 2, no competition. Rouen.—1, O. A. Young. 2, no competition. Ducklings.—1, Miss Jordan. *hc*, O. A. Young. ANY OTHER VARIETY.—1 and 2, T. C. Harrison (Pintails and Caroubast). Ducklings.—1, O. A. Young. *c*, Mrs. T. B. Dalby, Everingham; Miss Jordan.

PIGEONS.

POTTERS.—1, W. Adams, Ipswich. *hc*, E. Waites, Driffield. *c*, B. W. Hutton, Cranwick. CARRIERS.—1, W. Canupey, Beverley. *hc*, R. P. Moon, York. *c*, C. Potter, Driffield. JACOBS.—1, E. C. Davis, Hull. *c*, R. Sanders, Leven. FANTAILS.—1, W. Adams, Ipswich. *c*, R. P. Moon, York. TUMBLERS.—1, W. Adams. *hc*, J. Gilbert, Wetwang. BARBS.—1, A. Waites. *hc*, D. Maynard. NENKS.—1, W. Adams. *c*, R. P. Moon. ANY OTHER VARIETY.—1, W. Adams. *hc*, B. Leason. *c*, J. Stabler; H. Watson; W. J. Purdon. EXTRA.—Extra prize Mrs. J. Purdon (Creve-Coeurs).

RABBITS.—Any Breed.—1, A. M. Donkin. 2, J. Hudson, Leven. *hc*, E. Green; P. Ashton.

Mr. Edward Hewitt, of Sparkbrook, near Birmingham, was the Judge.

LIGURIAN QUEENS IN JERSEY, AND THE HONEY SEASON.

A CORRESPONDENT has lately related his misfortunes with an Italian queen. Two very similar cases have come under my own notice. Last autumn I procured three fine queens. One I put at the head of a hybridised stock in my own possession, she is now alive and well. A second I placed at the head of a strong black colony belonging to a friend, it was well provisioned for the winter; the queen was received well, and at once began to breed. In April, when I saw them, they seemed to be doing moderately well; the queen was breeding, and very few black bees were to be seen. I next saw them in June; the

queen was then not to be seen, neither was there any brood, and very few bees, but plenty of honey. The majority of the bees had dispersed themselves amongst the adjoining hives. This stock was lost. The third queen was placed at the head of a strong colony that had been strengthened by the addition of a stock of driven bees. These belonged to another friend. The queen was accepted, and began to breed, but during the winter I heard there was more mortality amongst the Ligurians than should have been. In April I opened the hive, and found only the queen and about two hundred Ligurians, a little brood, and plenty of honey. The next day the queen was found dead, and scarcely a bee left.

What could have been the cause of these two stocks thus dwindling to nothing? It puzzles me. Was it because the black and Ligurian bees could not agree? Was it a freak of the bees? Other correspondents have spoken of the honey season being very favourable, I wish I could say the same. My supers are not filled, nor are they likely to be. A Woodbury hive is almost entirely combed, but I do not think the bees have deposited more than 2 lbs. of honey. Two stocks in Woodbury hives weigh only 16 lbs. each, exclusive of the hive, yet they have both been strong all the summer. So far as I can judge, the honey season set in and lasted but a very short time, and then ceased quite suddenly. At one time there was every prospect of an excellent honey harvest. Last year was much better here. I had a Ligurian stock which threw three swarms, and yet by the autumn it was strong and well provisioned. Very dry seasons, contrary to general experience, would appear to be unfavourable; here, as in 1868, stocks grew lighter after the middle of June. Swarms, too, have been scarce here this season.—D. D. D.

[We cannot tell why your friends' ligurianised stocks dwindled in so remarkable a manner, but it certainly did not arise from any disagreement between the two races.]

THE HONEY SEASON IN WEST SUFFOLK.

To some of your readers an account of the honey season in this neighbourhood may be interesting. Though of very short continuance, the season has not been altogether an unfavourable one. It commenced on May 16th, on the morning of which day my stock hives averaged less than in the middle of April; between this and the 23rd, however, they commenced in earnest, two of my hives increasing in weight 14 lbs. each, two 13½ lbs. each, and the worst and smallest of all making 5 lbs. They continued doing well till June 21st, which day I consider the termination of the season, as they actually lost weight between the 21st and July 5th, since which they have slightly improved. Facts speak volumes. I give you the weights of two united swarms; it will be seen that 5 lbs. were made by one hive in one day.

Swarmed June 6th, hive and board 13 lbs.

	lbs.		lbs.
June 7	21	June 12	39½
" 9	35	" 13	35½
" 10	25	" 14	39½
" 11	27½		

Swarmed June 13th, hive and board 13 lbs.

	lbs.		lbs.
June 14	22	June 29	33½
" 15	24	July 1	33
" 17	26½	" 3	32½
" 18	27	" 5	32½
" 19	31½	" 8	35
" 20	31½	" 14	37½
" 21	33½	" 17	38
" 26	34		

My spring balance only weighing 40 lbs., I have not been able to weigh them since.

From one of Pettitt's single-box hives I have obtained 11 lbs. nett of virgin honey, and estimate what is now in the hive at 9 lbs., in addition to two excellent swarms. From one of his ten-frame bar-hives I have had one swarm, 23½ lbs. nett, a splendid super, and taken four bars for draining 23 lbs. nett.

I will not tire you with more at present, but if you think it will be interesting, I shall be pleased to give you an account of all my hives, the average and performance of the whole, bad as well as good.

I should be pleased to know the average of "SUDBURY'S" hives, "all told," and whether, which is not the case with mine, the bar honey will bear comparison with that from supers. Perhaps "RECTOR" will favour us in like manner,

and also give us the weight, when taken, of his gigantic super whether it was entirely free from brood, &c.

I have no doubt, also, that you would be conferring a favour on many readers of "our Journal," if you would, now the season is approaching its close, give us your advice as to the best method of disposing of our superfluous honey, the prices of different qualities, the best markets, &c. Why should we not know the market price of honey as well as of vegetables, &c.? —UITENHAGE.

TAKING HONEY AND INTRODUCING A LIGURIAN QUEEN.

I HAVE a very large and heavy stock of bees from which I want to take the honey, but without destroying the bees, and at the same time I wish to introduce a Ligurian queen in the following manner—viz., I would remove the stock to some distance in the middle of a fine day, and place the Ligurian queen, in a hive partially filled with comb, on the stance lately occupied by the full hive. Would the bees leaving the old stock and naturally going back to their old situation (the now empty hive and Ligurian queen) be likely to agree and make up a tolerably good stock?

[All the old bees would probably return to their accustomed stance, and being old bees would almost to a certainty destroy the Italian queen. The plan which offers the best chance of success would be to fumigate the colony, search for and remove their queen, and when the stupefied bees begin to recover bury the stranger queen in the heap, and permit the whole to ascend together into their new habitation, which should be put on the old stance, and the bees fed liberally by means of an inverted pickle-bottle filled regularly every evening until they attain a nett weight of about 20 lbs.]

FERTILISATION OF THE QUEEN BEE.

In your number of the 26th of May last, in a communication on the above subject by Mr. Fitzwilkins, allusion is made to the experiments of Mrs. Tupper to procure fertilisation within the hive. As I am entirely ignorant of these experiments, or of Mrs. Tupper's publication of them, will you kindly say where the information can be obtained? as the subject is one of the highest importance to all interested in apiarian pursuits. Until the statement of this theory in the Journal, I was under the impression that fertilisation always took place in the open air, and on the wing.

Supposing the above theory correct, if a second swarm of Ligurians, issuing ten days after a first swarm, be placed in an apiary surrounded by stocks of English bees, would it not amount to a certainty that the Ligurian queen would be fertilised by English drones, as I notice drones frequently enter other hives than their own? I am putting an actual case, in which the Ligurian swarm was taken from a pure Ligurian apiary, to which there were no English bees nearer than one mile, and shall esteem your opinion a favour as to whether the queen in question may be expected to breed pure Ligurians or hybrids, there being no Ligurian drones, as far as I could ascertain, with the swarm, which was removed on the day it issued.—G. RAYNOR, Tonbridge.

[Mrs. Tupper's process was fully described in our number published on the 28th April last, but so far as we know no one in this country has succeeded with it. We should expect the queen to be hybridised under the circumstances which you describe.]

OUR LETTER BOX.

GOLDEN-PENCILLED HAMBURGHS (W. S. D.).—Congratulate yourself on the tails of your Golden-pencilled Hamburg pullets; they will remain as perfect as ever in their markings, the only difference being they will become more distinct. The cockerels will not be in full feather till next November, and even then there are feathers remaining that to the practised eye speak of adolescence. They are, however, perfectly fit to show. If the legs of Pencilled Hamburgs are dirty they must be washed; the leaden-blue of the legs helps much in producing the ensemble that is so attractive. If the face is dirty it may be washed in cold water with a little vinegar in it, but the deaf ear must not be touched. This year's chickens do not really munt until next year, but they change their feathers little by little without becoming naked as they attain virility.

BRAHMA COCK'S MARKINGS (Carrier).—It is more than desirable to have the tail of a Brahma cock of a buff or fawn colour entirely. Failing that, it should be black, but if some of them are white-tipped or curled, it is not a disqualification, especially in an old bird. In fowls, as in

human beings, perfection is the exception. So far from a black breast being essential to a Brahma cock, many of our best amateurs prefer one spotted with white. We do not admire the description you give of the Brahma hen you have bred. With a brown colour and a black head, we should unhesitatingly class her among those which are inferior to the Grey or Pencilled birds.

JUNCOES' AWARDS (*Querist*).—We are very happy to give all the information in our power to those who use our columns, but we have no means of knowing the reasons that guide judges in their awards, or in withholding prizes. We should not dream of asking them.

BONE DUST—POLAND NOT LAYING (*Mrs. Bain*).—See Mr. Lingwood's advertisement in this Journal. It is very possible for a substance to be quite innocent when given regularly in small quantities, which would be very injurious when eaten suddenly in excess; but Mr. Wright only recommends the bone dust for large breeds. Possibly the Poland is too fat. As she appears well it will be best to leave her till after moulting, unless you like to try the effect of a spoonful of castor oil. It is not, however, always possible to tell the reason a hen stops laying. We have a Brahma which has stopped in the same way. Having no cock in company would not cause it. It is possible the bird lays, but eats her eggs.

PARROT BREATHING WITH DIFFICULTY (*A Constant Reader*).—We conclude from your statement that your Parrot has caught cold and is moulting; if so, keep it out of draughts, place a pan of water in the cage for it to bathe in, and give it bread soaked in cold water, squeezed rather dry, and occasionally soaked in milk for a change; Canary, millet, and hemp seed mixed, very little of the latter; Indian corn boiled; also a Chili or white peppercorn occasionally, and any ripe fruit you find it will eat; but if the bird pull out or bite off its feathers, then give it a good washing with water twice a day through a fine-sieved watering pot, and do not give it any Chillies, peppercorns, nor hempseed. You should notice what your birds like best, for what one Parrot is fond of another often will not touch.

LICE ON CANARY (*J. S. B., and Forest Hill*).—There is an insect-destroying powder sold by most druggists under the name of Persian vermin destroyer, or some similar title, which I have known to be very effectual in eradicating these pests. It is sold with a distributor, an indian rubber ball and tube, with directions for use, and is not expensive. Any respectable druggist will supply the right article, if I should have been somewhat incorrect in naming it. If the bird were mine I should wash it, but that is an operation I should scarcely recommend an inexperienced person to attempt, and especially so near the moulting season. A thorough ansting with sulphur will materially assist in dislodging the Acari.—W. A. BLAKSTON.

CANARIES NOT PAIRING (*F. W. Herbert*).—Are you quite sure that the necessary conditions for pairing are present? "Not to put too fine a point on it," are they cock and hen? Such mistakes will sometimes occur. It may be disappointing to persons who have only one pair of birds up, to find that they show no signs of pairing; but to those who breed on a larger scale it is only one of the many failures which are written on the debit side of the account. If the birds are in health there is no reason why they should not have paired, if fed even on the plainest diet. It is usual to give a little hard-boiled egg and hempseed as a stimulant. Try it, and induce them to make hay while the sun shines, as the season is nearly over. The German method of preparing birdlime is by pulling about 2 lbs. of linseed oil into a pot, to simmer upon the fire for some time, after which it is taken off and lighted with a match. In this state of inflammation it continues about two hours, when half the quantity will be consumed. By dipping, from time to time, a stick into the oil, and trying the matter between the fingers, its proper glutinous consistence may be easily ascertained, on which the pot is covered and the flame extinguished.—W. A. BLAKSTON.

COMMENCING BEE-KEEPING (*J. G. T.*).—The pamphlet which you mention is still in print, and can be obtained through any bookseller for one shilling. The common straw hive is the one most easily managed by a beginner, but it affords no facilities for improvement.

DEFICIENT HONEY HARVEST (*Horseshoe*).—Your bees have done quite as much as could fairly be expected from them, for you may rely upon it that Mr. Pagden's golden promises can only be realised (if at all) under the most exceptionally favourable circumstances. A strong swarm may fill a super the same year if the honey season be sufficiently prolonged, but it cannot be expected to do so when it issues so late as the beginning of July. As a rule, a stock that has swarmed will not afterwards fill a super during the same season, anything that Mr. Pagden may say to the contrary notwithstanding. Your friend's bees may have been hybridised by Ligurians, but are certainly not "half wasps," unless, indeed, they are defunct, and the Vespidæ and robber bees are ransacking their hive.

SOWING LUCERNE (*B. B.*).—There is much difference of opinion about the quantity of seed required per acre, but the universal practice seems to be to sow it in drills from 14 to 18 inches apart. Assuming the ground to have been ploughed neatly and straight, we have seen the seed sown in the alternate furrow slices before harrowing down, and in the case of a small quantity, as an acre or so, sowing may be done by hand or by some light drill. If you sow by hand, putting the seed into a common bottle with a suitable-sized hole in the cork, is as convenient a way as any. About March or early in April is the best season for sowing, and the ground ought to be kept clear of weeds for a time; after the plant has been once established it is capable of taking care of itself. Nevertheless, it is good practice to slightly dig over the ground in April, and harrow it to destroy the grass and other weeds which often grow amongst the Lucerne, taking care in digging to use only a pruned fork for the purpose. Lucerne likes a deep soil or one with a subsoil which permits of its roots descending, which they do to a great depth.

MUSHROOM CATSUP (*C. N. B., Dublin*).—We give you three modes:—1. Take 4 lbs. of mushrooms, and the same of common salt; sprinkle the salt over the mushrooms, and when the juice is drawn out add 8 ozs. of pimento and 1 oz. of cloves. Boil these for a short time, and press out the liquor: that which remains may be treated again with salt and water for an inferior kind. (2). Take the large flaps of mushrooms gathered when dry, and bruise them; put some at the bottom of an earthen pan, and strew salt over them; then put on another layer of mushrooms, then

salt, and so on till you have sufficient. Let them stand a day or two, stirring them every day; strain the liquor through a flannel bag, and to every gallon of liquor add one quart of red wine; mace, cloves, allspice, of each ½ oz., with a race or two of cut ginger. If not salt enough, add a little more. Boil it till one quart is wasted, strain it into a pan, and let it get cold. Pour it from the settlings, bottle it, and cork it tightly. (3). Take care that the mushrooms are of the right sort, and fresh gathered. Full-grown flaps are the best. Put a layer of these at the bottom of a deep earthen pan, and sprinkle them with salt; then add another layer of mushrooms, with more salt, and so on alternately. Let them remain two or three hours, by which time the salt will have penetrated the mushrooms, and rendered them easy to break; then pound them in a mortar, or mash them well with your hands, and let them remain two days, during which stir them up and mash them well; then pour them into a stone jar, and to every quart put 1 oz. of whole black pepper; stop the jar closely, set it in a stewpanful of boiling water, and keep it boiling two hours. On taking out the jar pour the juice clear from the sediment through a hair sieve into a clean stewpan, and let it boil gently half an hour; skim it well, and pour it into a clean jar or jug; cover it closely, let it stand in a cool place till the next day, then decant it off as gently as possible through a tamis or thick flannel bag till it is perfectly fine, and add a table-spoonful of good brandy to each pint. Now let it stand again, when a fresh sediment will be deposited, from which the catsup must be gently poured off into bottles which have been previously washed with brandy or other ardent spirit. Kept closely corked and in a cool place it will remain good a long time. Examine it, however, occasionally by placing a strong light behind the neck of the bottle, and if any skin appears upon it boil it up again with a few peppercorns. This is called double catsup, and a table-spoonful of it will impart the full flavour of Mushroom to half a pint of sauce.

METEOROLOGICAL OBSERVATIONS

In the Suburbs of London for the week ending August 2nd.

Table with columns: DATE, BAROMETER (Max, Min), THERMOMETER (Air: Max, Min, 1 ft, 2 ft), Wind, Rain. Data for Wed., Thurs., Fri., Sat., Sun., Mon., Tues., and Mean values.

- 27.—Fine; cloudy but fine; clear and fine.
28.—Densely overcast; overcast; clear, starlight.
29.—Cloudy but fine; densely overcast; overcast.
30.—Densely overcast; overcast; mild, overcast.
31.—Densely overcast; thunder; overcast.
1.—Densely overcast, damp; cloudy, thunder; foggy.
2.—Foggy, drizzling rain; foggy and overcast; densely overcast.

COVENT GARDEN MARKET.—AUGUST 3.

We have scarcely any alteration worth quoting. The supply of out door produce is well kept up, and a good attendance of buyers enables the growers to clear a large quantity of goods. The last cargo of West India Pines is now in the market. Foreign importations continue heavy, and include some very considerable consignments of Apples from the south of Spain, which are, however, of very poor quality. Good Regents are more plentiful this week among the Potato dealers.

FRUIT.

Table listing fruit prices: Apples, Cherries, Chestnuts, Currants, Figs, Filberts, Grapes, Lemons, Melons, Mulberries, Nectarines, Oranges, Peaches, Pears, Pine Apples, Plums, Quinces, Raspberries, Strawberries, Walnuts.

VEGETABLES.

Table listing vegetable prices: Artichokes, Asparagus, Beans, Brood, Broccoli, Brussels Sprouts, Cabbage, Capsicums, Carrots, Cauliflower, Celery, Coleworts, Cucumbers, Endive, Fennel, Garlic, Herbs, Horseradish, Leeks, Lettuce, Mushrooms, Mustard & Cress, Onions, Parsley, Parsnips, Peas, Potatoes, Radishes, Rhubarb, Savoy, Sea-kale, Shallots, Spinach, Tomatoes, Turnips, Vegetable Marrows.

WEEKLY CALENDAR.

Day of Month.	Day of Week.	AUGUST 11—17, 1870.	Average Temperature near London.			Rain in last 48 years.		Sun Rises.		Sun Sets.		Moon Rises.		Moon Sets.		Moon's Age.	Clock before Sun.	Day of Year.	
			Day.	Night.	Mean.	Days.	m.	h.	m.	h.	m.	h.	m.	h.	Days.	m.	s.		
11	Th		75.8	50.7	68.2	20	41	af	4	29	af	7	0	af	8	17	af	4	223
12	F	Birmingham Horticultural Show opens.	75.1	50.5	62.8	16	42	4	27	7	26	8	29	5	15	4	49	224	
13	S	Birmingham Horticultural Show closes.	74.5	50.0	62.3	19	41	4	25	7	47	8	40	6	16	4	39	225	
14	SUN	9 SUNDAY AFTER TRINITY.	72.9	50.8	61.8	18	45	4	23	7	5	9	50	7	17	4	28	226	
15	M		73.1	50.0	61.6	17	46	4	21	7	23	9	58	8	18	4	17	227	
16	Tu	Warrington Horticultural Show.	73.0	51.5	62.2	21	47	4	19	7	43	9	4	10	19	4	5	228	
17	W	Royal Horticultural Society Fnnit, Floral, [and General Meeting.	72.7	50.1	61.4	23	49	4	17	7	1	10	11	11	20	3	53	229	

From observations taken near London during the last forty-three years, the average day temperature of the week is 73.9°, and its night temperature 50.5°. The greatest heat was 92°, on the 11th, 1835; and the lowest cold 33°, on the 11th, 1864. The greatest fall of rain was 1.14 inch.

THE BLACK CURRANT.



Of all the kinds of bush fruit grown for the markets, the Black Currant is undoubtedly the most profitable. Its easy cultivation, the vigour with which it grows in almost all soils, and its great fruitfulness are all points in its favour. It flourishes in the cold Wealden clay, in which but few other fruit trees will thrive, and it is considered poor soil indeed in which the Black Currant will not grow; nor is its crop so much affected by being shaded during its growth as that of other fruits would be, for most flourishing plantations of it may be seen growing around and under standard trees.

But while all this may be said in its favour, it must also be granted that it is a gross-feeding plant, increasing in vigour in proportion to the quality of the soil, and it will well repay the fruit-grower for all the manure he can bestow upon it. Some little care is, however, necessary in regard to the way in which manure is applied: no practice can possibly be worse than to dig in manure in the way in which it is sometimes done, the fork going into the ground so deeply as to tear off quantities of the young roots, thus doing more harm than good. This deep culture may answer very well when the plants are young, but as they attain a larger size, and the roots gradually spread farther and farther, manure is best given as a top-dressing or in a liquid state.

In propagating the Black Currant it is a common practice to leave a clear stem of nearly a foot in length; now this is not only unnecessary, but is altogether a mistake, as it is impossible for such trees with their long stems to continue to produce such fine fruit as others, the branches of which spring from the ground erect and strong, and whose vigour and size is constantly increased by the sturdy suckers springing up and taking the place of the older wood.

As an example of what can be done with such bushes, I may instance two fine rows of Black Currants growing in the gardens of the Earl of Romney. These bushes are upwards of twenty years old; they were planted 6 feet apart, but have grown with such vigour that notwithstanding the freedom with which they have constantly been pruned, they are now 5 feet high, and the side branches of every tree touch those of its neighbour. Nothing can exceed the robust appearance of these splendid bushes. The soil about their roots has not been disturbed for some years past, with the exception of being deeply hoed on the surface a few times in summer, in order to work in the annual top-dressing of hotbed manure. In favourable seasons the fruit crop averages four gallons on each bush: this year it will not be so good, as the crop has suffered from the late spring frosts.

The sight of these large bushes, which from the vigour of their young growth appear likely to flourish for twenty years longer, and the large crops of fine fruit which they produce, are enough to set one thinking; and after making a calculation of the value of their produce at the rate of

4*l.* per quart, as given by "A LANCASHIRE SUBSCRIBER," in No. 470 of this Journal, so enormous is the total, and so much in excess of what it is customary to speak of, that one hardly likes to put it on paper. However, here are my facts, and I would ask all growers of fruit for profit to give them the notice they deserve. An acre of such trees planted 6 feet apart will contain 1210 plants, and taking the crop at 4 gallons or 16 quarts per bush, at 4*l.* per quart, we have the astounding sum of £322 13*s.* 4*d.* per acre. Now, I do not pretend to say that an acre of Black Currants has ever produced such a crop, but here we have forty-two bushes growing side by side, the yield of which has been up to this average in every favourable season for some time past, and therefore there can be no reason why an acre, or many acres, of such trees should not be capable of producing some such desirable results.

And this leads to the inquiry, Why is it that such fine Black Currant trees are not more frequently to be met with? It may be that the answer is contained in the fact that the hardy and accommodating nature of the Black Currant causes it generally to be planted in poor soil and in an equally bad situation, and so it is very rarely indeed that the requisite conditions are afforded to enable it to attain its fullest development.

Now these conditions are few, simple, and easily understood. Large juicy fruit always commands the best sale. Such fruit is only produced on the young vigorous growth of the preceding year; it must, therefore, be our aim to obtain an abundance of such wood by planting in a deep rich loam, by manuring freely, and by cutting away the old and thinning the young wood, so as to admit air and light. Such being the case, it must be admitted, that while no fruit tree is so useful as the Black Currant for planting in poor soil, yet none thrives better or yields such rich returns when enjoying the advantages of a good soil and generous treatment.—EDWARD LUCKHURST, *Figerton House Gardens, Kent.*

SELECT GARDEN ROSES.

DOUBTLESS as the autumn comes on there will be many inquiries for the best varieties of Roses for planting. In anticipation of these, I have made out a list which I think will not fail to please those who may select from it. The selection is taken from a large collection of Roses growing here, and I offer it with a view more particularly to suit those who contemplate making new plantations, or a rosery, and where the soil does not approach that standard of fertility generally recommended and required for the cultivation of the more delicate kinds of Roses. I have, therefore, excluded most of the latter, because, from experience, I consider it useless to plant anything but Roses of vigorous growth and constitution, unless the soil and situation be very suitable.

The site of the Rose garden at this place is good, being well sheltered from the north and east, but it is laid well open to the south and west; the soil, however, was very poor, a hungry-looking clayey loam, but now that it is well drained and enriched with manure it grows Roses well:

still for some years the delicate-growing sorts did not thrive. The frequent trenchings that the soil had to undergo in order to enrich it, and consequently the lifting of the plants, was a treatment too severe for any but the vigorous and robust-growing sorts; these, however, have thriven very well, and are included in the list below. I believe them to be a selection of generally useful varieties, and many of them exhibition Roses. Those with an asterisk I consider the best.

HYBRID PERPETUAL.—*Prince de Portia, vermilion; Mademoiselle Alice Leroy, pale rose; Madame de Cambacérés, rose; Duchess of Sutherland, rose; Alba carnea, white; Jules Margottin, cherry; *Comtesse de Turenne, pink; Duchess of Norfolk, crimson; *John Hopper, rose; Madame Clémence Joigneaux, red; *Jean Goujon, red; *Beauty of Waltham, cherry; *Baronne Prevost, rose; *Elizabeth Vigneron, pink; *Sir Rowland Hill, crimson; *Monsieur de Montigny, rose; *Rev. H. H. Dombain, carmine; *Géant des Batailles; Jean Rosenkrantz, red; *Paul Verdier, crimson; *Madame Boll, rose; La Reine, pink; *Madame Charles Wood, crimson; Triomphe de Caen, dark crimson; Duchesse d'Orléans, blush; *Marguerite de St. Amand, rose; Léopold Hausburg, carmine; *William Jesse, crimson; *Charles Lefebvre, crimson scarlet; *Souvenir de Comte Cavour, crimson; *Alfred Colomb, red; Miss Ingram, flesh; *Madame Alfred de Rougemont, white; Joseph Fiala, dark red; *Black Prince; Madame Fillion, salmon; Madame Moreau, bright red; Merveille d'Anjou, red; *Madame Vidot, flesh; *La Ville de St. Denis, rosy crimson; Pius IX.; Caroline de Sansal, flesh; *Pierre Notting, dark red; Charles Kouillard, rose; Madame Pulliat, dark rose; Madame Boutin, crimson; *Madame Knorr, rose; François Treuve, scarlet; *Mademoiselle Marie Rady, deep rose; *Comte Litta, scarlet; François Premier, red; *Anna de Diesbach, deep rose; *Auguste Mie, pink; *Le Géant, rose; Madame Rivers, flesh; *Reine du Midi; Thorin, bright rose; *Pauline Lausezeur, crimson; Antoine Ducher, bright red; Jean Lambert, red; and Prince Camille de Rohan, crimson.

HYBRID CHINESE AND BOURBON.—*Cbénédolé, crimson; *Coppe d'Hébé, pink; *Paul Ricaut, carmine; *Vivid, crimson; and Madame Plantier, white.

DAMASK.—*La Ville de Bruxelles, rose; and Madame Hardy, white.

ALBA.—Félicité (Parmentier), flesh; and *Queen of Denmark, pink.

GALLICA.—Grandisima, rose; *Boula de Nanteuil, crimson purple; Kean, purple; and Letitia, rose.

MOSS.—*Comtesse Murinais, white; Baronne de Wassebaër, red; Common Moss, and Perpetual White Moss.

TEA.—*Gloire de Dijon and *Homer.

The above sorts are suitable for growing as standards or dwarfs; being vigorous-growing they mostly succeed well worked on the Briar as standards, but the same sorts will become quite robust as dwarfs.

With regard to the planting of Roses, I may remark that the earlier in the autumn they are planted the better, especially in low damp situations; it is much the best plan to plant early and induce them to make as many roots as possible before winter sets in. Spring-planted Roses seldom do any good towards a first bloom.—THOMAS RECORD, *Lillesden*.

EARLY PEACHES IN THE NORTH.

ANOTHER season has confirmed my experience of Mr. Rivers's early Peaches. The trees were placed in the house in January; the heat was given to them on the 20th of that month, and was only enough to keep the frost fairly out. Early Beatrice ripened on the 3rd of June, Early Louise on the 7th, Early Rivers on the 10th; these were followed by Hale's Early and Rivers's White Nectarine a week later.

Early Louise was fair-sized and very good, but Early Rivers was both larger and better in flavour—in fact, I think it very nearly the best Peach I know; the flavour is so piquant that there is no fear of it ever becoming insipid from early forcing. And then with regard to earliness, it is only a few days later than the very earliest of Mr. Rivers's early varieties, a month earlier than Early York, and six weeks earlier than Early Grosse Mignonne (specimens of both these varieties standing between trees of Early Rivers), so that I feel assured it ought to be largely cultivated under glass. I find Rivers's White Nectarine to be very early, and to be one of the best in flavour under glass, and very vigorous and productive.

Midseason Peaches are so numerous that it is hardly worth while trying to get new varieties of them; but these early ones,

and also the late, show that much may still be done in both directions of earliness and lateness. At any rate, the attention of gardeners ought to be turned to these early varieties of Mr. Rivers's, for a month gained in earliness ought in every way to make them profitable.

The potted trees of these early sorts have their fruit buds fully formed for next year, are out of doors, and quite ready for having water withheld in order to set them to rest; and they might be placed in heat in November or December if early forcing were desired.—W. KINGSLEY, *South Kilvington*.

THE SALISBURY ROSES.

A VISIT to Salisbury is almost a necessary adjunct with me to one to Okeford Fitzpaine, and consequently on my return from my good friend Mr. Radclyffe's hospitable home I stopped at the old cathedral city, where Mr. Keynes was good enough to meet me, and, as my time was limited, to take me to his nurseries. Under his guidance, and that of his able and intelligent foreman Mr. Gill, I had a good opportunity of seeing his stock, and also of talking over the quality of the various new kinds introduced during the last two years.

There are some people who go to war for an idea. Here are two of the greatest of continental powers, like two big boys at school, determining to slay thousands of their fellow creatures, because one thinks and says, "I can lick you," and the other replies, "You can't; try it." But there are also some people who will not fight because of an idea. We have this year, except from the lists of the Crystal Palace, missed the vigorous onslaught of the knight of Salisbury; and yet that ought not to have been, for I never saw finer Roses than there were in the nurseries. But there was an idea that there would be no necessity for watering; and although Mr. Keynes has a river running at the bottom of his grounds, his Roses were not watered. Rain never came, although, as in most places, it threatened much to do so, and the result was that he was *hors de combat*, and the queen of flowers missed one of her doughtiest champions. But it is an "ill wind that blows nobody good," and so I had an opportunity of seeing the Roses un mutilated, and with a far larger amount of bloom than I should have done had Mr. Keynes exhibited as usual.

It is a great treat to a lover of Roses to see 30,000 all in one piece in full bloom, and in such fine condition as they were here—to see row after row of such fine flowers as Baroness Rothschild, Marie Rady, Marguerite Dombain, Louise Peyronny, Alfred Colomb, Duke of Edinburgh, and Joséphine Beauharnais. But this is an oft-told tale, and so, as a matter of greater interest, we will have a look at the new Roses, of which Mr. Keynes has a grand supply. As to those of last year, the following was the estimate we formed:—

Berthe Baron, a well-shaped Rose; pretty colour, and good. Charles Fontaine, a rich deep crimson Rose of good quality. Devienne Lamy, brilliant carmine; very large, well-shaped flowers, but will not answer on the Manetti. Dupuy Jamain, bright cherry colour. Emilie Hausburg, beautiful rose colour; an exquisitely shaped Rose. Henri Ledechaux, bright rosy carmine; very pretty. Madame Creyton, a beautifully formed Rose, and a novel colour—carmine shaded with rose. Marquise de Mortemart, blush white; very pretty, although at times inclined to be rough. Monsieur Journeaux, crimson scarlet; flowers large and full; a particularly beautiful shade of colour. Souvenir de Monsieur Poiteau, bright salmon rose, quite distinct in colour. Thyra Hammerich, a beautiful flesh-coloured Rose; a seedling from Duchess of Sutherland. Victor le Bihan, brilliant rosy carmine; flowers large and full.

It will thus be seen that a dozen Roses of last season were considered worthy of being retained; others which have been much spoken of, such as Julie Touvais, Madame Jacquier, Reine Blanche, and Clovis, were condemned. Of Tea Roses, Marie Sisley, Adrienne Christophe, and La Tulipe were considered good, the first two especially.

Of the new Roses of this year Mr. Keynes and Mr. Gill spoke very highly of Marquise de Castellane, raised by Pernet, the raiser of Baronne de Rothschild, and of Louis Van Houtte and Mdlle. Eugénie Verdier, both of which I have already noticed as fine. There are some Roses "well done" here, which one does not often see elsewhere. Joseph Fiala, Hippolyte Flandrin, an enormous Rose, not free-flowering, but at times giving Roses far larger than Louise Peyronny and more double, and Madame Moreau, are cases in point; while Maréchal Niel is in perfection here on the Briar, a stock well suited for all the Tea-scented Noisettes. There was a Rose the name of which I forgot to

get, probably Mr. Keynes can supply it; it was numbered 13, very dwarf, not growing more than a foot high, of a pretty bluish colour, and good shape.

Although Roses were my chief object, yet one could not pass by some other things which Mr. Keynes cultivates admirably. Need I say that the Salisbury Dahlias with which he first won his way to fame are as famous as the Salisbury Roses? and notwithstanding the excessive drought they were looking beautiful; while some seedlings that I saw seemed to me to be in advance of those we already have, notably a shaded purple of great beauty. But as Mr. Keynes will be a large exhibitor at the first exhibition of the new Metropolitan Society for the Encouragement of Florists' Flowers I shall have more to say of them then.

I have before now noticed the Vines at these nurseries, and again I have to express my wonder at the fine plants which fill the houses. To pick and choose from them would be simply needless, for they are all alike good; and I wish those good people who talk of Golden Champion being an indifferent grower could have seen the canes here from eye, quite as vigorous in every respect as the Black Hamburgs close by them. Of Royal Ascot, too, Mr. Keynes spoke highly, especially as a Vine for pot culture, for which its prolific character makes it admirably suited. These Vines, with their long stout canes, were not forced by stimulating manures; they were grown in nothing but leaf mould and good loam, and their appearance fully justified the treatment to which they had been subjected.

It is well known that Mr. Keynes sends out yearly some Verbenas raised by Mr. Eckford. I saw those of this season, and notwithstanding the drought they looked very well indeed. The finest as a bedder was Eclipse, but the others were also very good—Mrs. Eckford, Henry Eckford, Countess of Radnor, Miss Cole, and Sensation. The past season has tried Verbenas very much, and I fear they are gradually going out of estimation as bedding plants.

Such is a brief notice of what I saw at Salisbury. A finer stock, especially of Roses on the Manetti, I never saw; and one has only to visit such a nursery as this to see how universal is the love of the queen of flowers in these islands.—D., *Deal*.

EARLY PROLIFIC AND OTHER STRAWBERRIES.

The season for planting Strawberries having arrived, it may interest amateurs to hear something of the above splendid variety, raised from seed by that indefatigable amateur, W. Roden, Esq., of Kidderminster, and latterly made known to the public. After having admired, two years ago in Dr. Roden's garden, the fruit of his pet, he kindly sent me a few plants for trial. I increased them so as to form a nice bed of fifty plants, which had grown strong and capable of bearing a full crop the past season.

In consequence of the late cold spring my lot only began to bloom on the 10th of May, and it beautifully set its fruit, the first of which was ripe on June 15th, and the plants continued bearing for more than five weeks. To describe the beauty of this little bed in full bearing is impossible; suffice it to say that everybody who saw it was struck by the picture.

In size the fruit is rather large, of a very handsome even shape, mostly conical, sometimes flattened; its colour it is bright glossy vermilion from calyx to point; and as to quality, it is surpassed by none. The plant is of healthy growth, elegant habit, and easy propagation. I can holdly assert that the Early Prolific is the earliest of the large kinds, and it produces no fruit of inferior size. When better known it must become a general favourite, the more so as I found it very useful for early forcing in pots. Another point of recommendation is the fact that it stands the drought and heat better than most others. I am convinced that all fragarians will feel glad of my having called their attention to such a superior novelty.

Dr. Roden has another valuable seedling, the Duke of Edinburgh, a worthy companion to Early Prolific. This is a little later, but its noble fruit is larger still. Mr. Bradley's Sir Joseph Paxton, quite a gem here, is, I am sorry to see, but rarely mentioned across the Channel. It is later than the Early Prolific, but likewise a sort which will be grown as long as Strawberries are cultivated.

Of the late Dr. Nicaise's ten new seedlings, sent out last spring at exorbitant prices, I have as yet not been able to form an opinion. As far, however, as I have proved them, I believe that some of them will be useful additions to a choice collection.

Our Strawberry crop has been, generally speaking, small and of short duration. On account of the extraordinary drought and tropical heat of the present summer, the fruit of such soft kinds as Marguerite was roasted before completing its maturity. It is to be wondered that we should have had Strawberries at all.—FERDINAND GLOEDE, *Beauvais (Oise) France*.

AFTER reading Mr. Creed's paper on the Strawberry (see page 57), it has just occurred to me that a few more notes from another pen might be of service to those about to plant. My soil is a clayey loam, hard as a flint when dry, yet easily worked under certain conditions. The whole of my Strawberry beds I had trenched two spades deep, and as much manure as possible was put in. I planted the following sorts all grown under the same conditions, that is, throughout the dry weather they received no water, as I had it not to give—Rivers's Royal Hautbois, Rivers's Eliza, Dr. Hogg, President, Mr. Radclyffe, De Jonghe's Emma, Lucas, Nimrod, Stirling Castle Pine, La Constante, and Carolina Superba.

As regards the Royal Hautbois the flavour was excellent, and it bore better than I expected; I shall still grow some of this sort. Rivers's Eliza was exceedingly prolific, a good strong grower, producing some very good fruit, but this was rather surpassed by the Stirling Castle Pine in quantity, flavour, and colour, Mr. Radclyffe being equal with this variety in all these respects, but beating it in size. President was small with me and had but few fruit. Dr. Hogg did not grow well, and to my mind is not bright enough in colour. Lucas was also a shy bearer, also Nimrod, but both are good. La Constante was weakly and very small in fruit. Carolina Superba is not strong enough in constitution for my soil, and gives too small a crop. De Jonghe's Emma was very fine in flavour and colour, a free bearer, and certainly worth growing. After taking all qualities into consideration, for my stiff soil I have decided that Mr. Radclyffe and Stirling Castle Pine are my best two, very closely followed by Rivers's Eliza and De Jonghe's Emma; for I hold that one wants quantity as well as quality, and I also like a good bright-looking Strawberry, something that appeals to the palate through the eye. Lucas and President, also Dr. Hogg, I shall grow, but if they do not serve me better another year I shall discard them. I have only a dozen of President, and I shall not increase my stock. La Constante and Carolina Superba I shall dig in most of at once, on account of their weakly growth. Nimrod I shall try another year, but I think most likely I shall reduce my varieties to Mr. Radclyffe, Stirling Castle Pine, and De Jonghe's Emma, if the last go on as well as it has begun. I may here remark that I can do nothing with the British Queen in my soil, and also I may say that amongst all the foregoing sorts I do not think I had a dozen barren plants, which seem to have been so common with Mr. Creed.—HARRISON WEIR, *Weirleigh, Kent*.

IMPERIAL BLUE PANSY, EAST LOTHIAN STOCKS, AND BETA CICLA CHILENSIS.

PERHAPS one of the greatest acquisitions which has gladdened the hearts of bedders out lately is Imperial Blue Pansy. We may write it down as first-rate as surely as Golden Pyrethrum. The colour, a beautiful deep lavender blue, is all that can be wished for, and it is one that was much needed. The blooms seem to retain their depth of hue to the end—at least, there is no symptom of change as I write now, on August 4th. With attention to taking off decaying blossoms and pretty constant top-dressing, this Pansy remains vigorous in constitution and a mass of bloom all summer. What would be the best edging for it? I have Golden Pyrethrum, but it is too pale. Something more orange would be better. I am inclined to think its best companion would be Duke of Edinburgh bronze zonal Pelargonium.

The next plant I wish to express my gratitude to is the crimson East Lothian Stock. Here, again, we have a colour, which in the north of Ireland we have always found it most difficult to obtain in a mass. The uniform habit of the growth of this Stock, its durability, and the large proportion of plants bearing double flowers, entitle it to a very high place indeed. Golden Eagle Pansy would make a beautiful border for it.

Beta Cicla chilensis is a very beautiful and striking plant. It would be a magnificent border for a shrubbery, or a large bed of Dahlias or Rhododendrons. The stems, which are very broad, are most brilliantly coloured—scarlet, orange, yellow, magenta, rose, and white. It would, I think, be very handsome

in vases on a terrace, or as a pot plant for hall decoration. All who have large gardens and extensive grounds should try it next season.—Q. Q.

THE POTATO CROP.

This season has been a very peculiar one for the Potato crop in this neighbourhood (Hawkhurst); the severe drought caused a premature ripening of the tubers, especially in the second early, general, and late crops. Here we had no rain to speak of for fully four months, but last week heavy showers fell, which improved the condition of everything except the Potatoes. These are growing and supertuberating at an alarming rate. Acting upon the experience gained the year before last, when the Potatoes I left in the ground proved worthless for eating after having grown again, I have now decided on taking up all those sorts that have tubers of an average size, for, although the crop is small, I feel convinced that it is better to secure what I have than to run the risk of spoiling the present crop for the uncertain chance of obtaining a better one. I would advise others whose Potatoes are going in a similar way to take them up, because I acted on the same plan last year and the year before and did well.

But, perhaps, some will say that such Potatoes, if taken up, will not keep well. I admit that sometimes they will not keep so well as a fully-ripened Potato, but if a little additional care be bestowed upon them there will not be much to complain of in that respect. I say, Do not be in a hurry to finally store them, but do all that is possible to encourage ripening by keeping them spread thinly in a dry airy shed, from which strong light is excluded; then their tendency to grow will be checked, ripening will go on, and when they are finally stored in heaps they will not be so likely to heat or sweat, which would be sure to induce decay. My opinion is, that all Potatoes should be planted early; even the late sorts should be planted early or very late indeed. My plan is to plant for early crops as soon after January as the state of the soil will allow, but I like to have the late sorts in by the first week in March.—THOMAS RECORD, Lillesden.

FELIX GENERO ROSE.

I do not wish to impeach "D." of Deal's judgment with regard to Roses. I think, however, owing to the general vigour which he describes everything to have at Okeford Fitzpaine, he has seen Felix Genero through rose-coloured spectacles. Since writing about it, however, I have been told by two much better judges than myself that it is a good Rose, and useful for exhibition purposes; but the chief merit they attach to it is, that owing to its being of a different shade of colour to most Roses, it helps to diversify a stand of Roses, and acts as a foil to other and brighter colours. It also has the merit, which is a valuable one for exhibition purposes, of keeping its shape well after it is cut. My object in writing was merely to warn amateurs who have only room for, perhaps, 150 to 200 Roses, that it was not worth their while to order several of Felix Genero to the exclusion of other and better sorts; and though my friend, the Rev. S. R. Hole, was one of those who told me I had put too light an estimate on it, yet he himself has not so high an opinion of it as Mr. Radclyffe, if I may judge from the fact that when I was at Caunton on the 6th of August he had finished budding Briars to the number of 1440, and had not put in a single bud of Felix Genero. It may be by way of euphemy called a violet Rose, but with me it is dull red, with a lilac shade in it.

It may seem hereby on my part to venture to differ from Mr. Radclyffe, but I cannot see the wisdom of the advice which he has more than once given to amateurs who have asked for lists of Roses, to grow a hundred of Charles Lefebvre and a hundred of Jules Margottin. Many amateurs have only room for a few Roses to begin with, and certainly, good as Charles Lefebvre and Jules Margottin undoubtedly are, there are at least fifteen or twenty just as well worthy of cultivation.—C. P. PEACH.

ONIONS AT OKEFORD FITZPAINE.

The White Spanish are small. The Underground Onions also are not their usual size. The Portugal Onions are fine and still growing. The seed was sent by Messrs. Barr and Sugden, as received from Her Majesty's Consul at Oporto, Mr. Crawford. It was sown in pans, and kept during the winter in my vinery. The Onions were planted out in February, over

cow dung sunk in the winter. They are not yet full grown; the largest two are respectively 11½ and 11 inches in circumference. Between the plants runners of Dr. Hogg Strawberry were planted in the spring, the flowers taken off, and they are now fine plants.—W. F. RADCLYFFE.

"REDCARRE, A POOR FYSHER TOWNE."—No. 2.

I TOLD in my previous notes of the superlative sands which here margin the sea, and I have now traversed the whole, from the mouth of the Tees near Middlesbrough to Saltburn—full seven miles. Between the sands and the main land is an almost unbroken series of huge sandbanks, bound down by the roots of *Carex arenaria*, *Phleum arenarium*, *Triticum littorale*, and other species of the maritime Gramineæ. They and *Ononis arvensis* (Rest-harrow), *Erodium moschatum*, *Cakile maritima*, and *Galium cruciatum* form almost the entire flora of these rabbit-tenanted sandbanks. But the ledges of rocks called the Scars abound in what are called, with wrongful depreciation, Sea-weeds.

"Ah! call us not weeds, but flowers of the sea,
For lovely, and gay, and bright-tinted are we;
And quite independent of culture or showers;
Then call us not weeds, we are ocean's gay flowers."

Though "independent of culture," yet they may be made tenants of that marine flower border the aquarium. I have my hand upon a charming little volume, the author of which, Mr. D. Ferguson, a schoolmaster, is resident here, and an accomplished naturalist. He says:—

"The red weeds are the most beautiful, and we have succeeded in growing them very successfully, but some of them are so delicate that they seldom endure confinement for a very lengthened period; yet there are others of the more hardy kinds, as the *Ceramium rubrum*, *Rhodomyenia*, *Iridaea*, *Polysiphonia*, and *Pilota*, which answer remarkably well; and the pretty little chain-like *Chylocladia* also thrives, and gives the miniature rocks an interesting appearance. To the green weeds we must resort for oxygenisers. The Sea Lettuce, the Purple Laver, and the Enteromorpha, are under some circumstances the best. Then we have the feathery *Eryopsis* growing freely in the still waters of the tank; and one of darker shade in the rock-inhabiting *Cladophora*. Many of these are plants of annual growth; all are composed entirely of cellular tissue, those parts that approach most nearly to wood being only compressed cellular tissue, and destitute of fibre. Being always immersed, or at least covered with water during the greater part of their existence, they have no need, like terrestrial plants, of organs specially adapted to absorb fluids, but their whole surface acts the part which the roots alone perform in land plants; they have, therefore, no true roots and the pedicel or footstalk by which the plant is fixed to the rock, is simply an organ of prehension, from which it receives, not sustenance, but merely support. We find many of the microscopic Alge very beneficial in commencing a tank, though not so effective in the appearance of the tank as the more highly developed plants, yet they yield a large supply of oxygen, and stud the rocks with beautiful crystal bubbles; such plants are the *Lyngbya*, *Oscillatoria*, *Bangia*, and *Conferva*. Whatever be the selection of plant, care must be taken that each is adherent to a piece of rock; and always choose the hardest rock; the soft blue lias is very apt to thicken the water by giving off the alumina which it contains, when in contact with the sea water.

"In many of the pools, growing very luxuriantly, you will find the *Gigartina mamillosa*, a very peculiar-looking plant, nearly resembling the *Chondrus crispus* so very common on West Scar, but easily distinguished from it by its warty appearance. The only time we have ever seen the *Desmarestia aculeata* in a growing state was upon this rock, in such a condition very different in its appearance from the hard beach-worm specimens; when young, each branch is beset with the finest pencilled filaments of pea green, these are succeeded by stiff spines of dark olive, hard and woody in their texture; but when you first gather the plant, it is impossible to conceive a more lovely object waving its delicately feathered fronds in your vase of water. Attached to the roots of *Laminaria digitata*, Tangle, may be found the pretty *Nitophyllum laceratum*, whose prescribed locality seems to be the strong stems of *Laminaria*, rocks or stones, but rarely within tide-mark, but here, as the rock projects so far into the sea we reach the Laminarian region, and as thus enabled to find, in a growing state, many of the delicate *Rhodospiræ*, or red-seeded Alge.

You will find on the north side of the rock a good supply of *Delesseria alata*, *Winged Delesseria*, the extreme beauty of which makes it much sought after; and notwithstanding the common occurrence of it on our shores, is never seen without attracting admiration. With equal beauty, in rock pools near low-water mark, the Escent *Iridaea* (*Iridaea edulis*) presents its red feathery leaves, many of which grow together from the same root; and from its jagged and eaten appearance we should imagine it the favourite food of many of the denizens of the deep. Another of the red sea weeds adorns the sides of every pool, the *Laurencia pinnatifida*, though one of the most common, it is certainly the most variable of our marine Alge.

"A beautiful feathery sea weed often adorns the roots of *Fucus aeratus*, or the stems of *Laminaria digitata*, this is the *Ptilota plumosa*, and you will often find it to be the abode of an interesting Zoophyte the *Membranipora pilosa*. *Ptilota sericea*, a plant much finer in texture than the preceding, decks the lower ledges with its silky fronds.

"The *Odenthalia dentata*, though recorded as not occurring south of Dnrham, abundantly ornaments the lowest ledges of East Scar, and a ridge of rock on West Scar, easy of access at very low tides. The living plant presents a very different appearance to the dried specimen, which is much darkened in drying. We have grown this elegant plant with other *Rhodospiræ* tolerably successfully.

"The *Choudrus norvegicus*, Norwegian Choudrus, though rather rare, is found in the deep pools on the north side of the rock. In leav- the Scar, the beauties of which we have endeavoured to unfold, you will find the *Porphyra laciniata* densely clothing the ledges of rock nearest the shore; this is the Purple Laver, one of the *Chlorosperms*, or green-seeded sea weeds; though called purple, it assumes at different seasons various hues or shades. Many of the rarer *Algae* are only to be found at extreme low-water mark, or at the lowest water of spring tides, either along the margin of the rocks partially laid bare, or more frequently fringing the deep tidepools left at low water. The side of the pools richest in Red *Algae* will be found to be the northern or shaded side; whilst the olive, or green, require a sunny position to bring them to maturity."

On the afternoon of the day on which I collected many of the *Algae* so commented on by Mr. Ferguson, I wended my way inland to Guisborough, celebrated even in Drayton's time for its lovely scenery. He thus describes it in his "Polyolbion":—

"Mark Guisborough's gay site, where nature seems so nice,
As in the same she makes a second paradise;
Whose soil embroidered is with so rare sundry flowers,
Here large Oaks so long green; as Summer there her bowers
Had set up all the year; her air for health retir'd,
Her earth with alum veins so richly intermird."

The last line refers to the first alum works in England being erected at Guisborough by Sir Thomas Challoner in the reign of Elizabeth. He noticed that the strata here are like those near Rome, and obtained workmen from the Pope's works near that city. His success reducing the price of alum, the Pope anathematised Sir Thomas! but, as Graves remarks, "the Pope's infallibility is in this respect to be doubted—the heretic flourished, and so do his descendants," one of whom, Admiral Challoner, is now resident at Guisborough Priory.

What tales and doings of the olden time does the naming of that monastery recall to my memory. This was a wild district when the Augustine monks were settled here by Robert de Brus in the twelfth century, and so exposed to the Northmen's inroads that in the fourteenth a royal license was granted to the Prior and Canons to fortify their house sufficiently to protect them from pirates and other marauders, from whom they had suffered severely. "The Prior kept a most pompous house, inasmuch that the towne, consisting of five hundred householders, had no lands, but lyved all on the abbay; and a steward of theirs was turned out of office, because he had aforehande but onley four hundred quarters of grayne to serve their house. But nowe all these lordings are gone, and the countrey as a wydowe remainethe mournfull."—(*Cotton MSS*)

However, a good time has come again; for although only the east end of the Priory remains, a noble fragment, and an arch of the north side, yet they are surrounded by a well-kept garden, and beneath the old sacred ruin is a spacious wine-vault, suggestive of the adoption of this inscription—

"There are spirits above, there are spirits below,
There are spirits of joy, there are spirits of woe;
The spirits above are spirits divine,
But the spirits below are the spirits of wine."

From that vault a subterranean passage is said to pass to a plantation in Tocotes, and a legend tells that midway there is an enormous chest of gold guarded by a raven, which keeps incessant watch over the treasure. Once only was it invaded, but when the intending thief reached the chest the raven was transformed to a demon, who belaboured the intruder so severely that no one has repeated the attempt. There is little reason, if any, for doubting that the legend was founded on the known wealth of the Priory. At the time of its suppression it was endowed with the patronage of more than fifty churches, besides many other estates and privileges, among which were the right to claim fish from fishing cobbles of Redcar. But this was not the only contribution to the refectory table of the white-tunicked monks, for there are notices extant of annual benefactions of poultry and other good things to their larder and buttery. The produce of the dovecotes of their let farms was always reserved. Be it ever remembered, too, that they

were the best husbandmen, gardeners, and orchardists of their age. No better testimony to this could be quoted than the fact that the "five hundred householders" of Guisborough placed all their lands under the management of its monks, to benefit by their superior means and knowledge.—G.

HORTICULTURAL CONGRESS AT OXFORD.

(Continued from page 81)

The following paper is that read on the first day of the Congress, by Mr. William Ingram, of Belvoir Castle Gardens.

THE FORMATION OF SOILS.

INVESTIGATIONS into the history of soils lead us far back to a voiceless, but not unrecorded, antiquity; and, tracing effects to their causes, we shall find ourselves carried beyond the written records of men, beyond the æges of iron, and bronze, and stone, and we shall be left stranded amidst the bewildered and struggling creatures whose destruction was accomplished during that eventful time called by geologists the glacial drift period. Some writers on soils have attributed their occurrence and formation to atmospheric causes alone. This theory will be found insufficient to account for all the various circumstances of soil occurring in this country. The preparation of the surface soil for the growth of plants is mainly due to the action of the weather, and we all know that rocks, and marls, and clays, exposed to the action of the elements, are disintegrated and pulverised, and that the particles scattered by the wind, or spread over the land by rain, enriched and carbonised by vegetation, form, during long periods of time, considerable accumulations of soil; but such causes as these are not adequate to account for the immense masses of earthy material composed of matters derived from the rocky crust of the earth, and consisting, in one place, of deep beds of clay, in another of sand and gravel, or loam, and distributed, with more or less irregularity, over the hills, and valleys, and plains of this island.

After the deposition of the lower tertiaries it would seem that Britain and the north of Europe underwent a vast revolution as to climate, and that some new arrangement of sea and land took place at the same period. At all events, the large mammalia of the earlier tertiaries disappeared, and the land was submerged to the extent of several hundred feet, for we now find water-worn boulders on the tops of our hills at an altitude of 1800 or 2000 feet.

A cold period ensued, and icebergs, laden with boulders and gravel from other regions, passed over these latitudes, and dropped their boulders on our then submerged lands. How long this process continued it is impossible to determine, but by-and-by a gradual elevation of the submerged lands took place. Our hill tops and ranges appeared as islands, and our valleys as straits. These islands were now covered periodically with glaciers; during a brief season avalanches descended, glaciers smoothed the hill sides, and left the *debris* as morasses of sand and gravel.

In process of time the land was elevated to its present level, another distribution of sea and land took place, and the glacial epoch passed away.

The agencies in action during this time were eminently calculated, as no doubt they were designed, for the production of results of the greatest possible importance to us, "the latest gifts of time." It appears to me to have been the most evident period of preparation for the race of beings that was to become dominant on the earth, and to glorify by intelligent appreciation the gracious gifts of God.

To the action of these great forces of Nature—turbulent seas, icebergs, glaciers, and the streams from the great ice fields, as the climate changed—may be referred many of the drift soils which I have already said are widely distributed, and which wherever they occur give their own character to our agricultural and horticultural productions. Looking broadly over the vast fields of Nature, we see a ceaseless round of causes and effects, of processes and products. Change alone is dominant. While we enjoy the great results of time, we must not omit to read the great lessons written in what I may call the ripple marks of these ancient sea margins, which, while carrying destruction to the mighty race of mammals of that time, caused the production of vast areas of soil fertilised more or less by the decay of animals and plants which were coeval with and commingled in the *debris* of a vast disrupted world of matter?

The causes which have subsequently contributed to produce the more important deposits of soil, are less in magnitude, and in the process of soil-making are fortunately unattended by such wide-spread destruction as that which occurred during the drift periods. The ceaseless and prolonged action of rivers, commencing in periods incalculably remote, and coming down to the present time, have necessarily produced immense deposits of soil. We have all had opportunities of seeing how the devious course of a river is changed by the waters acting upon the banks that bound it. Masses of sand, silt, mud, and gravel, are annually displaced and deposited, and loam beds, for future fattening fields, are being formed, inch by inch, and year by year. Our true and best loam beds are our ancient and matured river deposits.

While the rivers pierce and ramify through the land, displacing and reforming new beds of the matters through which they pass, they still carry onwards some of the spoils of the land into the bosom of the sea. Sea and land, like rival monarchs, are ever striving for

* *The Natural History of Redcar and its Neighbourhood*. By D. FERGUSON. London Simpkin, Marshall & Co.

mastery. At the mouths of our great rivers we have islands or deltas constantly increasing, which are destined some day, perhaps, to be rich pastures, where prize stock will fatten, or fair gardens where champagne Grapes will win future medals.

But the sea is sometimes generous, and gives tribute to the land. This is attested by the rich alluvial tracts along our eastern coast, for where the land slopes smoothly to the ocean, and the waters roll over a shallow strand, every tide leaves a deposit which, increasing thus, is at last embanked, and forms the rich alluvial fields that Lincolnshire delights in.

I have already referred to the operation of the forces of the atmosphere on the exposed surfaces of the earth. In the comparatively equable climate of our own country such causes as heat and cold, wind and rain, are in constant operation, and, as we all know, assist us greatly in the preparation of land, and the labour we bring to bear upon the earth's surface assists the process of disintegration.

Having thus cursorily glanced at the causes which have contributed in the greatest degree to the accumulation, dispersion, and deposition of the earthy matters that result in soils, before proceeding to trace out in detail the various deposits of soil, spread like a garment over the stony framework of the earth, it will be as interesting as it is important to our inquiry to examine the great rock system of England. We shall by so doing be better able to trace back to their natural beds or formations some of the drifts or accumulations of soil which are found to occur, more or less abundantly, on different places.

From the western end of the Cheviots a mountain range commences, termed the Pennine Chain. It stretches due south through Northumberland, Cumberland, Lancashire, Yorkshire, Derbyshire, and with a break terminates in the small mountain range of Charnwood, in Leicestershire. A great part of this range is composed of carboniferous rocks, lying in an anticlinal ridge, and having the lower series of rocks in the centre and the upper in the flanks. Connected with this chain is a group of mountains, occupying part of Cumberland, Westmoreland, and Lancashire; these form the Cambrian group of the lake district, and present the highest summits in England (Helvellyn, 3,055 feet). The stratification of these rocks has been disturbed by intrusive masses of granite and igneous rock. The old red sandstone or Devonian has a considerable development in Herefordshire. That important section of the carboniferous system, the coal measures, occurs extensively in the north of England, Yorkshire, Lancashire, Derbyshire, Notts, Lincoln, and Stafford. The lower red sandstone fringes the northern coal field, and appears in Shropshire associated with the coal formation. The magnesian is found in Northumberland, Durham, Yorkshire, and Nottinghamshire. The new red sandstone spreads from the foot of the rocks already described into great rolling plains which occupy a large part of some of the midland counties; an extension of this system runs down the valley of the Severn, through Somerset and Devon, to the mouth of the Teign. A similar extension runs through the county of York to the Tees, while a third occupies nearly the whole of Cheshire.

The secondary rocks, from the lias to the chalk, strike regularly across it in a S.W. and N.E. direction, and presenting escarpments to the W. and N.W. The softer portions of these formations make plains or valleys, and the harder and stronger rocks long ridges of hills. We have thus the plain or valley of the lias running from Lyme Regis to Whithy. Over this comes the oolitic escarpment. As the chalk dips towards the east, it becomes overlaid by tertiary beds, which extend from Norfolk to Hampshire, with one remarkable interruption. This is a broad and elevated ridge of chalk that extends from Salisbury Plain to the N.E. of Winchester, where it divides into two ridges, one the North Downs, the other the South Downs. In the centre of this valley rises a ridge composed of Hastings sand, the beds of which have been largely removed by denudation.

The tertiary beds of the south-east of England are separated into two parts, occupying two basin-shaped depressions, called the London and Hampshire basins. Every rock formation which I have described has been more or less denuded by the operation of the various causes incident to the drift period, but notably by glacial action, and by the great boreal and the subsequent eastern drift. Had the carboniferous and red sandstone formations been composed only of rock, however powerful the action of the agencies brought into play during the pleistocene period, the resulting *detritus* would have been great plains of gravel and boulders—fragments, in fact, "confusedly hurled like relics of an earlier world." The preparation for the great events that caused the dispersion of soil had preceded the time of their occurrence. The ancient seas of the carboniferous period had formed from the waste of the granite, silurian and Devonian systems, immense beds composed of shales, clays, slates, and sandstones, while the profuse vegetation of the period added the coal beds. The displacement, amalgamation, and dispersion of these matters is evidenced throughout the system. The deep valleys that intersect the mountain masses of the carboniferous rocks show the amount of denudation they have suffered; and the *debris* are scattered far and wide over the land. Some of the best soil in the northern counties is composed of the matters borrowed from those ancient rocks.

Chatsworth, amongst other places, owes some of its deep-loam beds to the degradation of the neighbouring rocks; and the feeding meadows that surround ancient Haddon have lost none of their fertility although they fattened heaves for the hospitable owners of the Hall centuries ago.

The upheaval of the millstone grit in Derbyshire, and the subsequent waste of the stone, has formed over a wide extent of surface a poor, siliceous soil, which sustains heath and endless moors. This is an example of what I call a primitive soil, one obtained directly from the wash or decay of rocks or marl beneath. This, too, is first in my list of peat soils, on which I shall comment presently. The mountain limestone, which is one of the divisions of the carboniferous, is associated, but not intermixed, with grit. Its purely calcareous character separates the vegetation of the two rocks as widely as the poles; and while on your right you see the purple Heather blooming, on your left you have woods and corn fields.

The next important soil-producing formations to be noticed are those derived from the permian and triassic systems. These, by their subordinate elevation and central position, the previous character of their shells and marls, suffered greatly from the denuding action of the various drift currents to which they were exposed, and, consequently, contributed an immense amount of earthy matter over the whole face of the midland and south-eastern counties. The red loams, of which, fortunately, we have many examples, are derived from these marls, intermixed with gravel and vegetable *debris*. The Banter conglomerate of this system gave rounded pebbles, the gypsaceous beds of the lower series sulphate of lime; altogether the mineral matters from this system are of incalculable value in fertilising vast tracts of land.

An example is offered in this formation of benefits conferred but not enjoyed. The pebbly beds of the conglomerate remain undisturbed, a poor siliceous gravelly soil is the result, the marl beds below being out of reach. This affords some of the least profitable land in Nottinghamshire. A crystallised form of magnesian limestone occurs at Mansfield, but this is overlaid to a depth of 10 feet by beds of marl, interstratified with a band of limestone. As a rule, it is not safe to assume that the surface soil partakes exclusively of the character of the substrata, and contains its essential principles; and in recent discussions some eminent gardeners have made the mistake of supposing the surface soil above the dolomite rocks to be invariably made up of their *debris*, when in reality the rocks are too far below the surface to affect vegetation.

Descending in the series, we find the upper beds of the oolite, the lias, have suffered extensive denudation; an immense quantity of limestone, clay ironstone, has been swept away from the oolites throughout Leicester and the adjoining counties. The sweeping effects of the currents of the drift, as the land gradually rose, are very evident. The relics of our rocks, in fragments of stone, fossils, and ironstone nodules, may be found scattered through the gravel beds of the counties south-east of us, as well as filling some of our own valleys.

We hear occasionally of great agricultural as well as of horticultural achievements in our eastern counties. Sporting gentlemen tell of Turnips whose growth reaches the knees, and gardens eminent for the excellence of their products are known to us all; but while conceding a great deal to skill, I must, as a faithful chronicler of soils, attribute not a little to their influence in securing such favourable results. Throughout the northern and midland counties we find, as I have described, the great rock system scored, and rent, and abraded of a portion of the mineral treasures of the red sandstone, the oolite lias, chalk, swept away, and this grand compost spread as a dressing over the limy, craggy beds of Norfolk and Suffolk. Can we wonder that Turnips grow? or that "Mrs. Pollocks" are evoked? or that man has been rendered eloquent, when half a country has been broken up, and its fertile stores given to these happy lands in the east?

The cretaceous groups which comprise the chalk and the greensand are not very extensively developed, although the white chalk cliffs have given a name to our country. We are all more or less acquainted with one of the products of the Downs, which have given us a breed of sheep (Southdown) few fail to appreciate.

But little drift rests on our chalk hills, and the sparse flinty soil, though fertile with management, requires good farming or good gardening to bring it up to the mark. The numerous valleys which intersect the formation contain deposits of detrital loam, while beds of clay and gault occur in the system. The associated greensand formations are developed largely in Surrey, Bedfordshire, and Kent. The greensand of the latter county forms a base for the peat soils, which, according to certain notions, produce a wonderful effect on the growth of Heaths. The upper and lower greensands are, under good cultivation, valuable for early cropping and for seed lands. The two well-known examples of the tertiary system which I shall instance, are the London clay and the Bagshot sand. I cannot speak in terms of very high commendation of the horticultural capabilities of London clay. It is very hard to work, and, like a dull boy, requires a good deal of keeping up when it reaches the friable point. It does not equal the lias, plastic, or gault clays, when made into a soil.

I have spoken a little regretfully of the waste of some of the formations, but when I approach the Bagshot sand, that dreary waste of comminuted silica that runs through parts of Surrey, Sussex, and Hampshire, I can only say that it is a matter for regret that some of it at least was not overwhelmed, like Norfolk, and either its sandy wastes swept away or covered over with a few feet of loam, which, were it spread upon these heathy barrens, would make this tract of country smile like a garden. The pebbly beaches and sand beds, poor and hungry as they seem, are gradually submitting to reclamation, and being healthy, are attracting the smoke-dried Londoner, who may

gather health, if not profit, in the pursuit of gardening under difficulties. But we must forgive the general sterility of this formation when we remember the Rhododendrons and Azaleas, and the vision of beauty we have before us now in Oxford in Mr. Jackman's varieties of Clematis.

The natural world is replete with examples of agencies compensating wasted powers, and effecting restoration—evolving new forms. We have seen how the hills have been riven and washed, and the fragments spread far and wide over the land and sea. An illustration of the saying, that nothing is ever lost, is before us in the rich, alluvial plains that are found in Lincolnshire and elsewhere along the coast. If any one wants a proof of the influence of soil and situation on animals and plants, he should go first to a hilly inland district in Derbyshire, and after looking at the cattle and the crops, he should proceed to Peterborough, Wisbech, Sutton Bridge, or to Sleaford and Boston—he would find cattle double the size, and corn crops at least twice as productive as in the colder country. Here we come to a grand result, and a great example, in showing what soil and situation will do. A realisation of an almost perfectly fertile condition of land is a sort of philosopher's stone to gardeners; and what often gives additional value to these fine alluvial plains, is that beds of silty gravel are found beneath them, and form the best natural Drainage. Nothing is wanting in such fortunate districts but increased elevation (50 feet heavenward). Some of our best seed grounds are found on these rich tracts, and the principle is quite right, to grow seed stocks on the most fertile land; there will then be no retrogression of type.

It would be interesting in a horticultural point of view, and at the same time it would tend to illustrate my subject, if I could follow out the river system of England, and write the story of all the streams that, springing from the heart of the country, flow ever onwards towards the sea. In the present instance I can only venture to indicate very slightly the influence of rivers, regarded in the light of soil-producing agents. A great arterial river is a great power moving through the land, and together with its tributary streamlets, which gather their quota of earthy matter from the land adjacent, effects great changes in the distribution of soil.

The gravel beds of a river help us to understand the history of its wanderings. Pebbles of quartz and grit, and eroded fragments of granite, a lump of mountain limestone, tell us that the water has passed over an ancient drift bed. The Trent gravels are very much made up of the pebbles from the Bunter conglomerate, and the meadows that spread out through its wide valley show, in occasional sections, that the rich loams that belong to it were borrowed from the marls and red sandstones, through which it has for so many miles forced its way.

An immense gravel bed fills up the valley of the Thames to a distance of fifty miles. The gravel is composed chiefly of chalk flints. The great beds of loam which rest from one to several yards in thickness on the gravel bed, appear to be an alluvial deposit of the post-pliocene time. This loam, derived from calcareous formations, clay, greensand, and gault, is an extremely valuable soil for garden purposes. I know three tributaries of the Trent; one passes through a great clay formation, another comes from the iron beds of the inferior oolite, and passes through lias clay and marl stone—its gravel is but the stone from the beds over which it flows. Another takes its rise amongst oolite hills, and in ancient times has given large sandy deposits to the valley through which it runs. An anxious gardener might look upon these light soils as suitable for American plants, he would be woefully deceived; derived from limestone they still possess some of the properties of that mineral, and are inimical to Heaths and Rhododendrons when planted in them. Each of these rivers, in a comparatively restricted area, has formed loamy deposits, which, derived immediately from, are exclusively characteristic of, the formations through which they pass. From these examples I judge that tributary streams bring down more waste in proportion from the land than the main streams, and give a more varied character to the loam beds that are formed in the main valleys.

I must not conclude my story of the soils without referring to the peaty deposits and the bog lands, which, having a special botany, are of greater interest and importance to gardeners than many ordinary soils. Nature has infinitely multiplied her forms of life, and adapted them to every circumstance of soil and position found in the world; nothing seems so abhorrent as utter barrenness. The desolation of our moorlands would be complete were it not for the Heather and Gorse, the Fern, Moss, and Lichen.

The weathering of the millstone grit gives us a poor siliceous soil; decaying Moss, and Lichen, and Heath, in process of time add the vegetable *pabulum* necessary to support these hardy denizens of the mountains. The greensands in Kent and Surrey, the Bagshot sands in Sussex and Hants, afford examples of peat soils. Wherever poor sandy drifts occur, heath and peat soil is found.

Bog is a product of decayed vegetable matter due to moisture; an alteration in the level of a district has caused the submergence of extensive forests, and so a black vegetable soil is formed. Most large rivers have boggy deposits, due to inundations, and to the course of the river being encumbered with weeds and rubbish, just as the Upper Nile is at the present day.

The value to us of either peat or bog is due to the fact of their perfect freedom from the taint of stronger soils. Pure sands and vegetable matter are always safe to employ.

In endeavouring to recall instances of an exceptionally favourable development of vegetation arising from the influence of soil, the mag-

nificent Oaks in Bagots' Park, North Stafford, are vividly brought to my recollection. The park is 1000 acres in extent, and splendid specimens of Oak timber occur all over it, but notably in the case of the Beggar's Oak, the Squire Oak, the King and Queen Oaks. These are giants amongst trees, and exhibit perfect vigour and health.

Knowing that red marl occupied to a great extent the country about Bagots, I had assumed that these trees were luxuriating, as they often do, in the rich marl beds of the red sandstone. A subsequent and closer inquiry proved my assumption erroneous.

The park is thinly covered by beds of the lower lias which have escaped denudation. These beds have not been disturbed by cultivation. A section on the north side of the park shows 1 foot of drift clayey soil, few pebbles, 2 feet clay, 2 feet laminated shale with micaceous particles, 3 feet mixed clayey rubble, 3 feet shale.

Nothing can be more unpromising, on first looking on this section, than the soil. The secret lies in the fact that all these apparently poor beds contain an exact balance of the mineral constituents of fertility in a state of slow decomposition. They are compact, without being too retentive of moisture.

I may, in conclusion, advert to the singular advantages enjoyed, in an economical point of view, by the assemblage within a comparatively restricted area of all the more important rock formations that belong to the earth, and by the position of these rocks, by which they are rendered accessible to, and their peculiar products more readily available for, the uses to which they are applied by man. England epitomises the world in its rocks and rich mineral products; such a land is a fitting home for representatives of the great races of the world, whose energy and intelligence have found a home and fitting field for the exercise of the best and highest human faculties. A land endowed like this is a fitting school for a hardy and enterprising nation, and the varied knowledge gathered in the pursuit of the industrial arts, manufactures, mining, agriculture, and horticulture, has fitted the adventurous men, the pioneers of civilisation and Christianity through the world, for the great works they are destined to accomplish. I think I may truly say that Englishmen generally are content to win laurels by successes achieved in prosecuting the arts of peace, in conquering the unproductive soil of those countries whose undeveloped resources remained too long in abeyance under the sway of the savage. The agricultural and horticultural productions brought together in this city of learning help to illustrate my remarks. The cereal riches and the blessings spread far and wide over the world, in fruits that gratify every sense, and flowers that gladden the very soul of man, are presented to us. The lessons gained in these bloodless encounters, these modern wars of the Roses, are carried by our ever-departing pilgrims to their distant habitations; and it is the glory and delight of our brothers in their far-off homes to gather together their flowers and fruit, and emulate the work of this, the parent Society of the world of horticulture.

The next paper which we shall give is that of Mr. Williams, of the Victoria Nursery, Holloway,

ON PITCHER PLANTS.

THE plants upon which, with your permission, I intend to offer a few cultural remarks to-day, and of which I have brought a few small specimens for your inspection, are amongst the most curious of Nature's productions which have hitherto been introduced to our gardens. They are known popularly as "Pitcher Plants," from the curious ascidia or pitcher-like bodies which terminate the midrib of their leaves.

In treating of Pitcher Plants, I shall confine myself exclusively to the genus *Nepenthes*, although, did time permit, the genera *Sarracenia*, *Darlingtonia*, and *Cephalotus* would be found equally deserving of attention.

Of *Nepenthes* we have now a considerable number in cultivation. Some are hybrid forms, which have been produced in this country, but the majority are introduced species, and, what is very singular, we appear to have introduced the least interesting kinds first. There are many large and most remarkable forms yet to introduce, which will be grand acquisitions for our plant stores. The names of those in cultivation are—*Nepenthes ampullacea*, *N. ampullacea picta*, *N. distillatoria*, *N. distillatoria rubra*, *N. Dominiana*, *N. gracilis*, *N. gracilis major*, *N. hybrida*, *N. hybrida maculata*, *N. Hookeriana*, *N. lavis*, *N. phyllamphora*, *N. Rafflesiana*, *N. sanguinea*, and *N. villosa*.

Some of these are hybrids which have been produced in the establishment of Messrs. Veitch & Sons; but beautiful as many of them are, they are entirely eclipsed by some kinds yet unintroduced, such as *Nepenthes Lowii*, *N. Rajah*, *N. Edwardsiana*, *N. Boschiana*, and some others, which I am extremely anxious to see in cultivation.

Many absurd stories are in circulation respecting the uses of the curious ascidia developed at the extremities of the leaves of these plants. The most popular amongst these describe how the plants are endowed with such extraordinary vitality as to enable them to grow in arid sandy deserts, where nothing else in the shape of vegetation exists; that they have the power of distilling water to fill their pitchers; that the lids are closed down to prevent evaporation; and that birds, animals, and even man is accustomed to resort to them to allay their thirst with the cool and pure water found therein. It is scarcely requisite for me to state that these are nothing but pretty fancies, the fact being that they grow in boggy swampy soils, and cannot exist long in an arid atmosphere.

In *Nepenthes Hookeriana* and *N. Rafflesiana* an extraordinary alteration in the form of the pitcher takes place as the plants attain height. Thus, the leaves which are near the base, and the lateral growths, produce pitchers broad at the base, broadly winged in front, with ciliated hairs at the edges, and the long petiole is attached in front, and passes up between the wings. But in the pitchers produced higher up the stem a wonderful alteration takes place: the petiole is attached behind, the pitcher becomes narrow at the base, and the wings entirely disappear. To the cause of this alteration of form I have utterly failed to obtain the slightest clue, and I should be extremely glad to hear the opinion of any gentlemen present who may have given some attention to the subject.

The species of *Nepenthes* appear to be entirely confined to the Old World, and chiefly find their homes in the islands of the Indian Archipelago, where they grow in boggy soil at considerable elevations—in indeed, in some instances up to 9000 feet—the mountain of Kina Balon, in Borneo, appearing to be their head-quarters. Two species (*N. cristata* and *N. madagascariensis*) are found in Madagascar; the Philippine Islands also produce one or two species, which, however, are not peculiar to them, and one species (*N. gymnochora*), which grows plentifully in Java and several other islands, is also found in New Caledonia. Another species (*N. phyllamphora*) is said to grow on the Khasia Hills, at an elevation of some 3000 feet, and this is probably the extreme northern limit of the genus.

Few people have had the pleasure of raising *Nepenthes* from seeds, and this brings me to my principal object in writing these remarks; for as there are a quantity of grand species yet to be introduced, a few of which I have already named, and as it is not generally known that the seeds of these plants do not long retain their vitality, I wish to impress upon the minds of any and all who are either about to proceed to the countries they inhabit, or who may have friends resident there, the absolute necessity there is that seeds should be sent home by post as soon as gathered; and I wish our home cultivators to remember that these seeds should be sown immediately upon arrival, irrespective of the season. It has been my good fortune, during the course of my gardening experience, to raise young plants of *N. distillatoria* both from home-grown and imported seeds, and I may safely say the pleasurable feelings created in watching their curious leaves unfold, far surpassed that derived from the growth of any other seedlings, but at the same time, the doubts, hopes, and fears for their welfare were equally increased.

Under the impression that an account of my system of raising these seeds may be of service to some, I shall in concluding this paper offer a few remarks on that subject. The seeds having been obtained, take a well-drained seed pan or pans, and fill up to within an inch or two of the top with a mixture of peat and Sphagnum moss in equal parts, adding a little silver sand to keep it sweet. Upon this the seeds should be sprinkled, and not covered with soil. This may seem wrong to those obtaining the seeds for the first time, because they will appear to be large, but, if examined, they will be found to be in reality very small, and enclosed in a long loose tunic-like covering, which is evidently a provision of Nature to float the minute seed to a safe position for its germination. This loose coat also serves to protect the roots during the early stage of existence, for it is some time after germination before roots are protruded from the tunic. The seeds having been sown, the pan must be either covered with a bell-glass, and plunged into a bottom heat of about 80° or 85°, or what is better, the seed pans should be placed in a small close frame, where this heat can be maintained. In this temperature they should begin to germinate in the course of a month or five weeks; and it is very curious to observe that the very first leaf which is formed after the seed leaf is like a little pitcher—not like those you see upon the plants now before you, but very much resembling miniature leaves of the *Sarracenia purpurea*. These are produced freely and quickly, and the plant soon resembles a little ball, with its numerous almost sessile leaves. As soon as the roots begin to spread, the seedlings should be transplanted singly into very small pots, but still kept in the same temperature and close moist atmosphere until they begin to assume their normal form.

These plants will succeed either in pots or in baskets. I prefer the latter, because they display their beauties to the greatest advantage; but whether grown in pots, baskets, or tubs, or planted out in a prepared border, it must be borne in mind that they require more surface than depth, and that the soil must be open to allow their black woolly-looking roots to spread. Frequent applications of water over the foliage, through the agency of the syringe, will be necessary during the day, and a liberal supply to the roots will be found advantageous. These rules being attended to, and the plants shaded from the sun's rays to a greater extent than is usually done, *Nepenthes* will not be found difficult to cultivate, whilst their unique and peculiar beauty is a never-failing source of wonder and astonishment.

In conclusion, I sincerely hope to see the species we already have, cultivated to a far greater extent than has hitherto been the case, and the fine species from Borneo and the surrounding islands speedily introduced to our gardens.

THE ROYAL HORTICULTURAL SOCIETY'S GLADIOLUS SHOW.—As will be perceived by a notice in our advertising columns, this will be held on Wednesday next; and as good prizes are offered, both to British and foreign growers, nurserymen and

amateurs having each separate classes, we expect an excellent exhibition. The Hollyhocks, too, notwithstanding the drought we have experienced, will no doubt contribute their share to the interest of the Show.

APPLETON-LE-STREET FLORAL AND AGRICULTURAL SOCIETY.

It is not our practice to notice the exhibitions of local horticultural societies unless there is something in connection with them which calls for especial notice, and which has an interest for our readers far beyond the district in which the exhibition is held. Such a Society is the Appleton-le-Street Floral and Agricultural Society, founded three years ago by our valued correspondent the Rev. C. P. Peach. It is because of the singular success which has attended the progress of this Society, and the impetus it has caused in the neighbourhood, that we give it this prominence; and it is also as an encouragement to others to do as Mr. Peach has done that we state the following facts. In 1868 the total number of entries of horses, cattle, sheep, pigs, and poultry was 254. In the following year they amounted to 308, and this present year they reached the extraordinary number of 434, of which 203 were for horses. In the horticultural department the same ratio of increase was maintained, and as evidence of the quality of subjects shown in that department we give Mr. Peach's comments on an exhibition which attracted great attention.

"I have seldom, if ever, seen a better collection of Carnations and Picotees than those which were exhibited by Mr. George Edwards, of York, at our Floral and Agricultural Show, at Appleton-le-Street, on the 26th of July. They were all seedlings of Mr. Edwards's own raising, and reflect great credit upon the care and attention which he must have given to the plants before he could have brought them to that state of perfection. As one of the Judges of the Carnations and Picotees at the late Royal Horticultural Exhibition at Oxford, I am convinced that those exhibited by Mr. C. Turner, of Slough, were the only ones at all to compare with these seedlings of Mr. Edwards's, which he sent here. Mr. Edwards was second to Mr. Turner at Oxford, but, having to contend with a more northern climate, his blooms were too backward to compete with Mr. Turner from Slough, but if he had been able to get his seedlings which he sent here forward enough for competition, it would, in my opinion, have been a very near struggle.

"Among the seedlings sent by Mr. Edwards, the best were—George Edwards, scarlet flake Carnation; Mrs. Edwards, purple flake; Mr. Paley, rose flake; Mr. Dove, J. Davidson, Mrs. Smith, and J. Holliday, bizarres, of which the latter seems to me a great acquisition.

"Among the Picotees the following struck me as of great merit:—Ada and John Feather, heavy-edged red; Fairy and Sweet Lucy, light-edged red; British Sailor, heavy-edged pink; Rosa and Mrs. G. Edwards, light-edged pink; Delicata, light-edged mauve, the latter a great acquisition, one of the best mauve-edged Picotees I have ever seen, and John Feather equally good as a heavy-edged red. Mr. Dove has the quality, a very valuable one in exhibition flowers, of lasting well, and will, in my opinion, prove a very useful addition to the list of show Carnations.—C. P. PEACH."

The amount of money received has been also in proportion to the increase of the exhibitions. In 1868 it was £90; in 1869, £128; and we believe this year it will be as much as £150.

STRAWBERRY CULTURE.

We are agreed upon the necessity of eradicating sterile plants, and propagating only by runners taken from fruitful stocks, or stools. We might venture to add, and agree, that runners drawn from stools not worn out, as well as fruitful, are still better than when drawn from old, although fruiting stocks. In other words, runners off stools at most of one and two years' growth are best, as partaking of the fruitfulness and vigor of their parentage or stock.

We are not, however, quite agreed upon the mode of planting our runners, some adopting the ridge-and-trench (Potato fashion), and some the level bed plan, the plantations in each mode being in single rows, varying from 12 to 15 or 18 inches in the distance of the plants apart laterally and longitudinally. Bed or ridge is the question in comparative merit. In either event—bed or ridge—the land is easily trenched spade deep, and interlaid, or underlaid, with rotten manure, the merit of

each plan being so far equal. The planting, too, in lines or rows is also of equal merit. It is when we come to the ridge that the merits of the bed and ridge plans diverge. The ridge plan forms parallel mounds, with the soil drawn or sloped upwards, the plants sitting on the summit and drooping into the intervening trenches or open drains. Have any of your readers observed that the plants are thus occasionally blanched like Celery, and that sometimes the ridges drop or fall, and the plants perish from exposure to drought, or frost and cold winds? And has it been noticed that the trenches carry off, like drainage, the moisture so essential to the Strawberry in its period of swelling before ripening fruit? And has it been seen that ridges cannot be easily mulched or top-dressed, the manure tumbling into the trenches, and having its virtues washed away as sewage? Such features in ridge planting have occurred under my own observation, and I place them before your contributors for comment.

The bed is my choice. Beds 4 feet wide, to reach across from each side in weeding, &c., with two rows of Strawberry plants, all equidistant, say 12 inches, the ground trenched and underlaid with manure, are my system. Thus the plants sit firm and hard beneath the wind, the ground retains its natural moisture, and the mulching with short litter and manure by hand or weeding-fork is little trouble, the mulching being also allowed to remain as a winter protection, and to sink into the beds. It neither blows nor washes away. Weeding is all that is needed, and that is easy across 4-foot beds with 12-inch pathways between. Thus I plant, grow on two to three years, and trench, manure the soil, and plant and mulch successively the same beds (no rotation of crops) satisfactorily.

Many growers use straw for protection from dirt in the fruiting season. Straw has the worse property of enticing birds and slugs, as well as damping and moulding the fruit in damp weather; besides, straw confines the heat of the earth, and makes the under sides of the Strawberries soft and watery in flavour, at least I think so, and I use nothing except, for a choice stool here and there, a few broken flower pots or tile layers and reflectors. Netting for bird-scaring, and vegetable charcoal dust and sharp sand, hand-scattered, for slug protection!

As regards the sorts of Strawberries fancied, we may differ as we are located. My choice is Lucas, President, Eclipse, Rivers's Eliza, John Powell, Fairy Queen, Filbert Pine, Dr. Hogg, Frogmore Pine (though Frogmore Pine ripens badly in dull weather), and Wonderful; and taken all in all—flavour, size, and productiveness, I think them the cream. Of La Constante, La Chalonnaise, Marguerite (washy), Sir Harry, and Cockscorn I can make little but a few far-apart fruit not worth the room of the plants. However, "tastes differ."—READER.

GARDENING AS A RECREATION.

I would recommend every man in the autumn of his life to take to gardening, if he has not already experienced its pleasures. Of all occupations in the world it is the one which best combines repose and activity. It is rest-in-work or work-in-rest. It is not idleness; it is not stagnation—and yet it is perfect quietude. Like all things mortal it has its failures and its disappointments, and there are some things hard to understand. But it is never without its rewards. And perhaps if there were nothing but successful cultivation, the aggregate enjoyment would be less. It is better for the occasional shadows that come over the scene. The discipline, too, is more salutary. It tries one's patience, and it tries one's faith. The perpetual warfare that seems ever to be going on between the animal and the vegetable world is something strange and perplexing. It is hard to understand why the beautiful tender blossoms and the delicate fresh leaflets of my Rose trees should be covered with green flies and destroyed as soon as they are born. It is a mystery which I cannot solve; but I know that there is a meaning in it, and that it is all decreed for good, only that I am too ignorant to fathom it. And even in the worst of seasons there is far more to reward and encourage than to dishearten and to disappoint.

There is no day of the year without something to afford tranquil pleasure to the cultivator of flowers, something on which the mind may rest (using the word in its double sense) with profit and delight. If there is no new surprise, no fresh discovery for you, there is always something to be done. "The garden is a constant source of amusement to us both," wrote Dr. Arnold in one of his delightful letters—he was writing of himself and wife; "there are always some little alterations to be made, some few spots where an additional shrub or two

would be ornamental, something coming into blossom; so that I can always delight to go round and see how things are going on." In the spring and summer there is some pleasure-giving change visible every morning, something to fulfil and something to excite expectation. And even in the winter, flower culture has its delights. If you have a greenhouse or conservatory, no matter how small, you have an in-doors garden, in which you may watch the same changes and enjoy the same delights. And if you have not, you may still do something to preserve your nurslings during the rigours of the hybernal season. Indeed, there are few states of life in which floriculture is not an available enjoyment. To rich and to poor it is a blessing equally accessible. "As gardening," it was observed by Sir William Temple, who has had a new lease of life in one of the best of Macaulay's "Essays," "has been the inclination of kings and the choice of philosophers, so it has been the common favourite of public and private men, a pleasure of the greatest, and the care of the meanest; and, indeed, an employment and a possession for which no man is too high or too low." I am disposed, indeed, to think that to men of low estate it yields greater joy than to those who hail from high places.—(*Cornhill Magazine*.)

VIOLA CORNUTA.

ALLOW me to inform Mr. Robson, that although my *Viola cornuta* and Yellow Pansies were not planted until June, I have never seen them do better. They have been, and will yet continue for some time, a perfect mass of blossoms. They are both new introductions here, and have been the admiration of thousands. Indeed, the bedding has been very much admired, more especially the mixed and tricolor beds. The old style of bedding solid masses of colour has to a great extent been abandoned this season for the first time, much to the gratification of all who visit these grounds.—EDWARD BENNETT, *The Gardens, Enville*.

DOUBLE-FLOWERED PELARGONIUMS AS BEDDERS.

I HAVE to thank "D., Deal," for his article on this subject at page 78. I agree with his remarks as to the suitability of double-flowered Pelargoniums for bedding purposes. As "D., Deal," says, there are no seed pods—undoubtedly a great advantage of double-flowered varieties as compared with some of the single-flowered sorts, of which Christine and most of the Nosegays require almost daily attention to keep up a decent appearance during dry hot weather. In rainy weather the flowers of the double kinds, though much more compact in the truss than the single-flowered, are not so soon destroyed by wind and rain; indeed, a heavy rain spoils the beauty of the single-flowered sorts for a time, until, in brighter drier weather, more flowers open. The double-flowered kinds are not in the least the worse of a heavy rain, but should the weather continue dull, as it often does for several days together, the trusses, from being so close, are "matted together;" the whole truss, from the decay of a few flowers in the centre, is then soon a mass of white mould. During bright hot weather is when they shine, as do all kinds coming up to the florists' standard of excellence—those with good trusses of well-formed flowers, as Lord Derby, Editor, and others, which "D., Deal," grows, and which more of us would grow if they flowered profusely and recovered more speedily after wet and cold. The double and large-flowered kinds suffer less from wet and cold than the smaller-flowered, but during a continuance of wet they damp to a pitiable extent, and are very slow of recovery.

However, like "D., Deal," I am so well satisfied with my experience of them out of doors that I intend to give them a more extended trial, and would advise others to do the same. All seasons are not wet; in a dry bright summer they greatly outvie those we should not keep except for their free continuous blooming. But why discard kinds whose only fault is a free vigorous habit? Are there no large beds to fill, or back lines in borders where height is an advantage rather than otherwise? Gloire de Nancy has rosy scarlet trusses very effective for large beds; Madame Lemoine is of course to be preferred for smaller beds and where low growth is desired, but the idea that all our plants ought to be pigmies if they are to have a place in our gardens seems ridiculous. We might as well lay down a carpet at once as fill our beds with dwarf plants only. Height is as necessary for effect as colour, and quite as essential in producing harmonious pleasing arrangements. The great evil of

our flower parterres is having the plants huddled together. There is, no doubt, a great number of plants put in a small space. Distinctness of feature is practically ignored in flower gardening. Fewer and larger beds, with more space between, would do more to place our flower gardening on a level with a painter's ideal than anything else.

Of the double-flowered *Pelargonium* one most likely to meet our views of a bedding *Pelargonium* is *Madame Rosa Charmeux*. In habit, foliage, and flowers it resembles *Tom Thumb*, and is of similar dwarf habit and very free-flowering.—G. ABBEY.

THE FIG AND ITS CULTURE.—No. 7.

SETTING THE FRUIT.—How little we know really respecting this important process, and with the Fig least of all! In this, the organs of fructification being hidden from our view, we cannot tell how or when fertilisation is effected; therefore, it is but little we can do to assist matters. The time when it is supposed the setting takes place may be known by the eye, which assumes a pinkish hue and expands a little, thus giving admission to a little air into the interior, where the flowers are.

In many parts of Italy, and the south of Europe generally, especially in olden times, but still to some extent at the present day, the Fig cultivators pay much attention to setting the Figs, and very much has been written on what is called caprification. This is a practice much believed in by those who practise it, but is condemned by most modern scientific writers as absurd. The process, stripped of all its mystification, is a simple one. There is, in the first place, "a wild species called the Caprifig, on which it is said a certain insect exists, which enters the fruit when in a young state at the eye, thereby facilitating the entrance of light and air, or some fertilising vapour, whereby the flowers are enabled to set and ripen. In Fig plantations numbers of this wild species are planted for the sole purpose of bearing these insects, and at the proper season the fruits, with the insects, are carried and deposited on the fruit or shoots of the domestic species." There are in southern France the Fig trees, called *Caprifiguers*, which bear the insect, and also the men who carry and place these insects about. Without all this manoeuvring it is faithfully believed but very scanty crops of Figs would be secured, but this, according to my experience, is altogether a delusion, and is only alluded to here as such.

About the time when it is supposed the fruit is setting, it is well to be extremely careful as to all the conditions which would be likely to affect the plant. It is well to keep it in a uniform state as to moisture at the roots—it is better to be rather dry than otherwise—and to preserve an equable temperature, rather airy, if possible. The whole subject, however, is somewhat obscure, the particular stage and the particular treatment required being only understood by long experience.

CASTING THE FRUIT.—This is a result of defective setting. There can be little question respecting that. It is a very common occurrence, and altogether a very puzzling one. It most usually happens to the first crop, more rarely to the second, and some varieties are far more apt to do so than others, even particular plants have a greater tendency to cast their fruit than others. There is nothing more tantalising or vexatious in Fig culture than this. A plant may be loaded with beautiful fruit, which grow to a goodly size, and appear to be developing themselves beautifully, when suddenly they assume a yellowish sickly hue and fall from the tree. Very frequently this is the case with the entire crop on that particular plant. If these fallen fruit are examined by cutting them lengthwise, a great difference will be observed between them and those which do not fall. In the former there is a great cavity, the little florets of the interior are undeveloped, and there is no seed formed. In the others the parts have increased so much that the fruit is almost solid, seeds are there in abundance, and every part is perfect. It is clear, then, that the flowers have not set and the fruit falls, as with the Apple, Pear, Plum, or Cherry. With some fruits the setting is not material to its development, as in some of the Cucurbitaceæ, where the fruit so-called will grow and ripen without possessing a single seed. In the Grape, again, the absence of the seed only checks the development of the berry to a certain extent.

I need not, however, pursue this subject further, but inquire, How is the casting of the fruit of the Fig to be prevented? Get the fruit to set properly. How to do that I have already stated as fully as I am able, with this addition for trees grown in pots—Have the pots set on a bed of ashes, it is better than staging or shelving of any kind. It is cool and equable, always

retaining a little moisture, which is comfortable to the roots, which speedily find their way into it and enjoy it much. Some cultivators are very positive in ascribing the evil to direct causes, such as dryness at the root, or the reverse—too much moisture—or to some sudden check, as excessive cold, excessive heat, &c. In so far as these may affect the actual setting of the fruit they tend towards it, but not otherwise or further. Sudden checks, or extremes of any kind, are at all times injurious, and especially so at the critical stage of setting. I have tried experiments in many ways, subjected plants to every extreme, and the results have been very different from those which ordinarily occur without our sanction with plants well-known for their persistency in holding on their fruits; excepting by positive injury to the plant I have in no instance succeeded in the wholesale casting of the fruit, as is naturally the case. No, we want some power given us to set the fruit of the Fig, as we do Peaches in dull cloudy weather.

FRUIT-RIPENING.—Fruits of all kinds when ripening require a dry and bracing atmosphere, and rather cool than otherwise. Immediately the fruits begin to ripen less water should be given to the roots, otherwise the fruit will become watery and tasteless. With trees in pots only enough should be given to keep the foliage healthy, and at the same time a drier atmosphere should be secured in the house by syringing less,



Fig. 12.

applying more air both by night and by day, and applying fire heat if necessary for that end. With the first crop of fruit it is somewhat difficult to follow-out this practice exactly, as it is in a great measure injurious to the progress of the second crop; some modification is here required which can only be gained by experience. In some parts of France it is stated to be a not-uncommon practice to prick the eye of the fruit with a straw or quill dipped in olive oil. Brandy, also, is employed for the same purpose by dropping a little in at the eye, or through a puncture in the skin, the object being to hasten the maturity of the fruit and improve the flavour. I have had no experience as to its effects. I may just observe, as bearing somewhat on the point, that fruits damaged in the skin, or otherwise deformed or injured, are frequently much more highly-flavoured than the more perfect examples.

Figs, to be enjoyable, must be thoroughly well-ripened; a half-ripened Fig is simply abominable. The outward appearances which denote the highest excellence in ripe Figs are

these—The fruit is bent at the neck and drops its head a little; there is a large drop of juice at the eye, like a great tear; the sides are cracked lengthwise, and the juice is seen exuding a little and standing on the surface like great dewdrops on the petals of a Rose. That fruit is in a condition fit to eat, and its appearance does not belie its quality. With some varieties, such as the White Ischia, Black Provence, &c., and in warmer, drier climates, the fruits dry up a little and assume somewhat the character of a sweetmeat. These are simply delicious.

The engraving here given (fig. 12), represents the mode of production of the second crop of fruit in the axils of the leaves on the wood of the current year's formation, as stated in my second paper (vol. xviii., page 162), to which it should be referred.—A. B. C.

TO PREVENT CHASSÉLAS MUSQUÉ GRAPE FROM CRACKING.

EVERY gardener who has grown the Chasselas Musqué Vine knows how prone its fruit is to crack, and one of the finest Grapes in cultivation is rendered useless, if not worthless, by this unfortunate habit. An effectual method of preventing this has been discovered, and for some time successfully practised, by Mr. Speed, the talented gardener to the Duke of Devonshire, at Chatsworth. It consists in simply making a sloping cut half through the stalk of the bunch, not sufficient to weaken it for the work it has to do, but enough to check the flow of too much sap, which is evidently the cause of the fruit cracking. This cut is very much such an one as is used in "tongueing" when plants are layered.

LOOKER'S PLANT COVERS.

WE have no doubt that these are good plant protectors; their sides, being of earthenware, retain the heat accumulated within

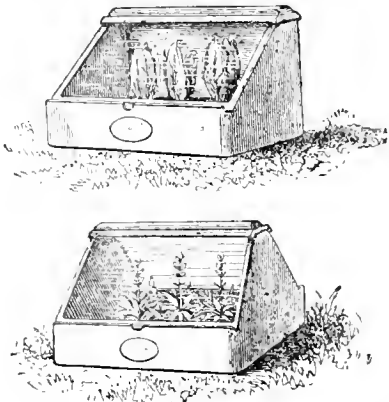

them, and exclude cold; but Mr. Looker is quite mistaken when he says they "generate" heat. Their ventilation is good, they are easily shaded and protected, and are very cheap.

WORK FOR THE WEEK.

KITCHEN GARDEN.

ALL vacant ground having been duly filled with crops of the Cabbage tribe, attention should be instantly given to *Celery*. The late crops of this should be planted forthwith, and the early crops carefully earthed-up. The following must be sown directly—viz., *Cabbage* for the main crops of next summer; Prickly-seeded *Spinach* for supplying the table from November to May; of *Onions*, the Welsh and Deptford for drawing young during the winter, also for transplanting in March for bulbing; *Radishes* and the various *Cresses* for autumn use; a little *Corn Salad*, and a little *Chervil*. Continue to plant *Endive* on elevated beds well manured; some of these should be so contrived as to admit of being covered with hoops and mats or other protection in winter. Let all forward *Onions* be laid immediately, in order to get them soon off the ground, which should then be manured and planted with *Colworts* in rows 15 inches apart, allowing 10 inches between the plants. Let the Marrow *Peas* have the best of sticks, and be sure to top

them when they reach the height of the sticks. If any of the *Parsley* is becoming too gross and forward, let a portion be mowed down at once; this is an old but a very excellent plan. A top-dressing of soot and dry soil, ashes, or sawdust, may be immediately applied. In this way fine young *Parsley* for garnishing will be produced by October. Dress *Tomatoes*, and see that all herbs are housed and the *Camomile* flowers picked when perfectly dry.

FRUIT GARDEN.

Proceed with thinning and nailing-in young shoots of all wall trees, if any remain unfinished. Peach trees, in particular, should now be kept closely nailed, in order that the wood may be ripened, and to admit air and light to the fruit. Remove a portion of the leaves where the fruit is too much shaded, and at the same time remove any nails with which it is likely to come in contact. If the weather is dry before the crop ripens, give the borders a good watering. Wash the trees occasionally, and trap earwigs; perhaps the easiest way is to place short pieces of beanstalks or other hollow stems in different parts of the trees, and look them over every second day, blowing the contents into a bottle and replacing the tubes as before. Protect with nets or canvas all ripe fruit intended for use late in the season, and net-up Currants and Gooseberries for late use. As soon as the crop of Strawberries is gathered, go over the beds and cut off all runners; fork the soil about the plants to encourage them to make a good growth before the growing season is past. Layer runners for new plantations. Use the garden engine occasionally in warm weather to prevent red spider.

FLOWER GARDEN.

Propagation by cuttings is now a most important business in this department. If time can possibly be spared, let there be no delay in this respect; not only mass flowers, but many in the mixed beds and borders, require to be annually propagated in order to insure their continuance. Such are sometimes termed imperfect perennials; as instances of these may be adduced such plants as *Pentstemon campanulatum* and its varieties, *Chelone barbata*, *Antirrhinum* in great variety, *Coreopsis lanceolata*, *C. auriculata*, and, better still, *C. grandiflora*. *Mimulus atroseus* also requires looking after, and deserves it. Many of these are old plants, but they are still useful in contributing to the general effect at least. Cuttings of *Pentstemon gentianoides* should be struck early; if well-established they will flower sooner than seedlings. The half-shrubby *Calceolarias* must be thought of, and such climbers as the *Maurandias*, the *Lophospermums*, and *Rhodochiton* should be well established in their store pots before winter. Intermediate Stocks may be sown for pots, and a little *Mignonette* in pots every week until the end of August. Let Rose-budding proceed, and for common purposes the old *Crimson Perpetual*, the *Bourbon Queen*, *Phoenix*, *Amosa*, *Lafayette*, *Aimée Vibert*, &c., are recommended. These, although not of the exhibition class, are nevertheless most useful about the pleasure grounds of a country seat. All the early layers of *Carnations* and *Picotees* will now be ready to take off. They may be potted singly in pint pots, and gently watered to settle the soil. When dry they should be put in a close cold frame for three or four days, till they have emitted fresh roots, when they may be gradually inured to the air. After the layers have taken root the pots should not be allowed to be drenched with wet, though they should be exposed to the air as much as possible. A good plan is to remove the pots, when ready, from the frame, placing them on a layer of coal ashes to prevent the ingress of worms, &c., and throwing a covering of calico over them when the weather is too hot, or during heavy rain. By these means they will be well established and hardened previous to being removed to their winter quarters. Continue to plant out *Pink pipings* when well rooted, shading and watering as occasion requires. Look well to the seed, which, with that of *Carnations* and *Picotees*, promises to be abundant. New or scarce sorts of *Dahlias* may be propagated by cuttings in a brisk heat. These make good pot roots. Trap earwigs by placing small pots half filled with dry moss on the tops of the sticks, and remove all imperfect buds as they appear. Attend to the preparation of the offset bed of *Tulips*, and regulate all small bulbs for planting.

GREENHOUSE AND CONSERVATORY.

No time should now be lost in putting all houses, pits, &c., in thorough repair. The glazing should be well seen to, and painting where needed. With regard to the interior of houses, the painting must ever depend on the crops. Whitewashing, however, can be managed at all times. The lime should have

abundance of sulphur mixed with it. No one need be afraid of using any amount on cool surfaces. The repairing and cleaning of flues will, of course, suggest itself, and the examination of boilers or other apparatus, where suspicion may rest, should be proceeded with forthwith. The end of August or early part of September is the most eligible time in the whole year to procure and carefully store loam and other materials necessary for special purposes during the next year. A good loam should be uniform in colour, rather tenacious, containing a fair proportion of fine and sharp sand, and somewhat unctuous when squeezed between the fingers. It should not, however, cake together too much on pressure. The more grass or other rank herbage it contains the better. It should be dug in a dry state, for if handled when wet its porosity, and consequently its power of transmitting moisture and air, will be in a considerable degree impaired. When removed to the compost yard it should be piled up in narrow ridges about 4 feet wide at the base, and as high as possible. If carefully placed the ridge will exclude much rain; it is, however, an excellent plan to place thatched portable hurdles against it, these may be removed in fine and settled weather for the purpose of air-giving. When it has been in the compost yard for a few months it will be found in excellent order for use, in fact, what gardeners term mellow. From the compost yard it should be removed to the potting shed in moderate quantities at a time, for if it lie too long there it becomes dry, and in this state it is not proper for compost. By the use of the thatched hurdles there need be no particular hurry in housing it; in doing this it should be cut down with a perpendicular face, and cleared thoroughly, in order that so precious a material may not be needlessly wasted. Give every attention to flowers for a late display. Everything intended for this purpose should be thoroughly established in the pot. Late shifting will never do here.

STOVE.

Take every means in due time to harden, or rather ripen, the growths already made. Give air very freely at all times, more especially when the atmosphere is warm, but shut up abundance of solar heat with a good amount of atmospheric moisture betimes in the afternoon.—W. KEANE.

DOINGS OF THE LAST WEEK.

KITCHEN GARDEN.

THE weather and the ground are so dry that planting-out is not to be thought of, except where water of some sort can be given. The sun on the 5th and 6th was as fierce and cloudless as ever. The amount of vapour raised must ere long give us clouds, and for these we shall be thankful. The dews in the morning have been our safety. The stems and leaves of plants were so filled and refreshed that they stood the sun pretty well. Water is now so scarce in this neighbourhood that it will be a great blessing if we be not visited with low fevers, &c., as in many cases working people can hardly find the means to secure cleanliness.

We sowed Turnips, Radishes, and Cauliflowers, and took up some forward Onions, to be followed by Cabbages; we also planted out winter stuff where we could give a little water at the roots. As to surface watering, that would be worse than useless. Plants well established will pump up moisture for themselves if left unwatered; puddle the surface, and you do little good, and for the time you deprive them of the supply from beneath. No common watering given at the surface in soil so dry as ours would have much chance of reaching the bulk of the roots. In different circumstances the treatment may be different.

At present, in these drying days our chief resources are *mulching* and shading. The breaking the surface of the mulching is next to giving a fresh layer. Our Celery beds would have been dried up but for shading. The Celery, as a ditch plant, likes a little shade in summer, even in ordinary seasons, and much more when it can have only a minimum of water in a season like this. What has often surprised us is the quickness with which a moderate mulching disappears. The earth, the air, and the roots together soon make short work of it. Where we could not well mulch, the surface of the soil has been frequently stirred with a Dutch hoe. As one proof of dryness, we may state that the walks in the pleasure ground have had scarcely a weed all the season, and we could only switch them to freshen them now and then. We have never had wet enough since March to consolidate them with a roller,

and without a certain amount of moisture beneath it is of little use to pass a roller over them.

FRUIT GARDEN.

What we have stated of mulching applies equally to fruit trees. Applied when the ground is warmed, besides excluding drought, its tendency is to entice the roots near the surface, and thus encourage fertility rather than over-luxuriance. We have gathered Joanneting and Red-streak Apples, but though clear fruit, they are small. With more moisture, the quantity as well as quality would have been good. As a great saving of water, we have mulched our fruit trees in pots with horse droppings previously allowed to heat. This is the third time this summer, and though each time mulched rather heavily, the mulching had all, or nearly all, disappeared before we repeated the dressing. As a saving to watering it is most effectual. To help us still more, though not looking so particularly neat, we mulched a good part of the floor. We did this all the more as the only water we could give was rather strong, and we were afraid to use it largely. We shall not here enter into the manurial question, though we feel convinced that even in this respect the roots get the benefit of the mulching. There is no question that it often saves the top of a plant when otherwise it would be dried up.

All at once, though scarcely seeing any wasps for the season, we have been attacked by myriads. Hives of bees have also made free with the best Gooseberries. The wasps threatened to make such a clearance of rather hard, though fine fruit of the late Florence Cherries, that we gathered them in self-defence. We shall have to use gauze, &c., to keep them from our best fruit in houses. Fine Peaches may be secured by means of a very thin layer of wadding, the paper side next the fruit, and the woolly side out. The wool baffles the wasps, as their legs become entangled in it. It is well to catch wasps early, but this year we hardly saw any all the season, and these were captured. Until within a few days we thought we were to be free of them for the season. They and ants, we fear, will speck the best Apricots. As to the *ants*, we should manage them if we could give soot and lime water, allowed to stand until as clear as brandy, and if a little guano were dissolved in it all the better, if the liquor were clear, as that would increase the smell of ammonia, which ants dislike. Well washing the trees from the top downwards would dislodge the ants and bring them to the ground; then a sprinkling of guano at the foot of the wall will generally succeed in making them decamp. If the ants are all brought to the ground, the most effectual means for preventing them going up again is to paint a cordon at the foot of the wall with tar and oil, say 2 or 3 inches wide. So long as the tar is moist and keeps its scent they will not pass it. A piece of wadding dipped in tar may be tied round the stem of the tree, and that will take away that ladder from them. Proceeded with potting Strawberries as detailed last week, and would have done more but for the scarcity of water. Many rather large plants must be given up, and smaller ones substituted. Many things have received less air and more shade than usual, in order to save the watering-pot.

ORNAMENTAL DEPARTMENT.

As yet the flower beds stand better than the Cabbages do, but the latter had no mulching except their own leaves. A few *Calceolarias* have succumbed, but not so many as to make vacancies. Nothing but the heavy dews in our case could have saved them.

Most of the *Verbenas* have succeeded well; that which has done worst—that is, stood the dryness worst with us, is the *Maonetti*, called also *Impératrice Joséphine*. Both as a broad edging and as a carpeting for beds it is just alive, but furnishing fewer of its pretty striped heads of flowers. Among the *Verbenas*, it seems to be as sensitive to dryness as the Black Prince Strawberry is among Strawberries. With a few showers and dull days this little favourite would still be fine. Another old favourite of ours, and which also used to be a favourite for groundwork with Mr. Robson—the little lilac *Verbena pulchella*—has thriven remarkably well, blooming profusely, and looking as fresh as a *Mesembryanthemum*. This fine old sort is not grown so generally as it ought to be. Its soft lilac-bluish colour gives a pleasant relief to more gaudy flowers. When fairly planted it generally looks after itself, running along the ground and rooting as it goes, without troubling one with pegging down. In fact, for the generality of plants, to save labour, we scarcely peg down anything; we would rather fasten and keep secure by twigs which the branches would cover, and depend for symmetry on the natural heights of the plants. Many a fine group is destroyed as respects symmetry

by neglecting to study the natural heights of the plants. Some time ago we saw a large bed of *Ageratum mexicanum* laid down and pegged so as to present a low flat surface. There were rests and planks laid across the bed, so that the men should properly do the work. The bed was solitary, or at least not in direct combination with others, and therefore there was no necessity obvious to the passer-by why the heads of the flowers of the *Ageratum* should be on a level with the grass, instead of 18 or 24 inches above it. As the bed would be some 18 feet in diameter, a bed showing from half to two-thirds of a globe in outline would have been much more telling, looked far more natural, and would have cost but a tithe of the labour. When such plants must be used in regular groups, there would be more excuse for pegging and tying down, but the desired end would in every way be better secured by at once using plants of the necessary height that would require no such torturing. Stopping and pegging must often be resorted to in the case of coloured plants used as edgings; for instance, *Perilla*, *Amaranthus*, *Iresine*, and *Cineraria maritima*, but even they always look best when there is little necessity for pruning or cutting them. Some massive lines of *Iresine* with us have never been touched, and they only want a little moist weather to make them look beautiful. We like to see *Iresine* best when bathed with dew.

We have commenced cuttings for the beds next season; will take a few *Verbenas*, *Heliotropes*, &c., first, and then will follow with variegated *Pelargoniums*. If we can manage we will place all, or as many as possible, in small shallow wooden boxes, so as to be easily moved, and they pack closer than pots. On an average, our cuttings will have from 1 to 1½ inch each, and will be small, to take up little room in winter.

We have had a busy week potting and overhauling Ferns; for drainage and mixing we used a good deal of charcoal, and as we were scarce of it we made a few barrowloads by the quick and handy process we lately detailed. We were rather anxious that our readers would guess what the *Coleus* bed at Woburn was edged with, as we might have gained some new idea; but we find that to prevent many inquiries we may as well state at once that the edging consists of a double row, from 16 to 18 inches wide, of the *Polemonium caruleum* variegatum. There was hardly a leaf of the *Polemonium*, except a few central ones, that would not average fully 9 inches in length, and beautifully coloured and marked. We have seen and tried a great many plants in combination with the *Coleus*, but such fine-leaved plants of this *Polemonium* seemed to leave everything else we have seen far behind.—R. F.

TO CORRESPONDENTS.

. We request that no one will write privately to any of the correspondents of the "Journal of Horticulture, Cottage Gardener, and Country Gentleman." By so doing they are subjected to unjustifiable trouble and expense. All communications should therefore be addressed solely to *The Editors of the Journal of Horticulture, &c.*, 171, Fleet Street, London, E.C.

BOOKS (*Mr. P., Salisbury*).—You will find a treatise on Vines in pots in the "Vine Manual," which can be had from our office by post for thirty-two stamps. (*Prudence*).—"Greenhouses for the Many" will give you the instruction you require for erecting a greenhouse, and "Flower Garden Plans" will furnish the other information you ask for. The former can be had from our office, free by post, for seven postage stamps, the latter for 5s. 5d.

RENANTHERA LOWII.—In page 85 the quotation is from the "Botanical Magazine" for 1864, not 1864.

GARDENERS' EXAMINATIONS (*Jos. Bowker*).—Apply to Mr. Richards, Royal Horticultural Society, South Kensington, W., and he will supply you with the information.

CARNATIONS (*Old Subscriber*).—We cannot recommend tradesmen. Any of the leading florists who advertise in our columns will be able to supply you.

VINEGAR PLANT (*J. G., Chester*).—This is the mycelium of a mould, *Penicillium glaucum*, found on liquids undergoing acetous fermentation. We do not know where it can be obtained. The Fern is *Scelopendrium vulgare* ramo-ferosum.

ARACARIA IMBRICATA (*W. R.*).—It has frequently produced cones and seeds at Bicton, and in other gardens, but such an occurrence cannot be said to be common.

SELECT HARDY ROSES FOR STANDARDS (*J. W. Boyd*).—Gloire de Dijon, orange yellow; Cécile Forestier, bright yellow; Pierre Notting, rich dark crimson purple; Jules Margottin, cerise pink; Baronne Prevost, rose; Baronne de Maynard, lovely white; Maurice Bernardin, rich vermilion; Marguerite de St. Amand, pink flesh; William Griffiths, salmon pink; and Charles Lefebvre, rich crimson. I should buy new plants. The only really fit land for Briar Roses is rich land with 20 per cent. of rich clay in it. For inferior soils the Manetti stock is the best.—W. F. RADCLIFFE.

ROSES NOT SUCCEEDING (*C.*).—It has been a very trying season for Roses. I should stir the surface of the ground and water the plants well. September is a good month for rooting. You ought not to have cut down your plants so late as September. The wood made after that time could not have been sufficiently matured to stand well so severe a winter, followed by a late cold spring. If you cut down your Manetti plants or Roses on their own roots, it should be done in the spring. If you wish to remove them, it must be done cautiously, as you will disturb and perhaps injure the new rootlets. If your land is wet and needs draining, you had better take up the plants and trench the ground.—W. F. RADCLIFFE.

EXHIBITING ROSES (*Inquirer*).—A single bloom of a Rose is certainly not a truss, and the committee of the show must clearly have understood so, otherwise why did they specify one class to be shown as "one bloom each," and the other "one truss of each?" The only wonder is that any doubt should have arisen on the subject.

ROSES LADY SUFFIELD AND FELIX GENERO (*Q.*).—I cannot tell the weight of the Strawberry which measured 1½ inches in circumference. Lady Suffield is a beautiful and successful Rose, raised by Mr. William Paul, of Waltham Cross. I am glad you agree in admiring Felix Genero. Mr. Taylor, of Fencote, Yorkshire, wrote on June 30th.—"Felix Genero is quite extra, but it was raised by Damazin, and not by Lacharme, as you said." Since "D." of Deal, left here on July 16th, he visited Mr. Keyes's nursery, and wrote—"I saw many specimens of Felix Genero, and they were very good." I spoke of the Rose on the Manetti stock.—W. F. RADCLIFFE.

LONG SHOOTS ON ROSES (*Frank Wilson*).—We cut back all our Hybrid Perpetual Roses after flowering, shortening the flowering shoots to within five or six joints of their bases, and the long shoots we cut back about half their length, or shoots of 4 feet we reduce to 2 feet, and in this way we keep the plants compact, and have flowers in autumn, with the wood well ripened at its base. We should cut the shoots back about half their length at once. There is no good in a shoot 4 feet long reduced three-fourths at the winter pruning, all the best buds are cut away, the worst retained. Dwarf Roses should be planted 3 feet apart every way. Bones are first-rate manure for Roses, whether applied in the form of half-inch bones, or as dust. Of hair we have no experience, but do not see why it should not be a valuable fertiliser.

MAKING VINE BORDERS AND PLANTING THEM (*P. P.*).—The beginning of July is the best time for planting Vines, as they have then time to become established before winter. After August is too late, we would then prefer planting in spring. We should likewise prefer leaving the making of the border until then, as if it is made now the soil will become considerably solidified, if not soddened, before spring, and the Vine roots will, consequently, not take so readily with it.

GONIOPHLEBUM APPENDICULATUM (*T. H. V.*).—We should not consider this a variegated Fern. Though it has distinct reddish veins and minute spots on the pinnae, yet it is no more variegated than some others, as *Blechnum corcovadense*. To be variegated, the plant should not only have more than one shade of coloring, but the markings must be distinct, as in *Pteris argyrea*, *P. tricolor*, &c.

GARDENIA PROPAGATION (*C. A. G.*).—Take cuttings now from the shoots of the current year, or those that have growing points, and with the base rather firm, or what is termed half ripe; insert them in a pot well drained and filled to within an inch of the rim with silver sand and sandy peat in equal parts, and to the rim with silver sand. Place them in a bottom heat of from 70° to 75°, and in a corresponding top heat, and keep them moist and shaded from bright sun. They will be well rooted in about six weeks, when they should be potted off singly, and again placed in bottom heat until established.

CANNA SEEDS NOT GERMINATING (*Caroline*).—The seeds sent to us of *Canna indica* coccinea we believe are sound and will yet vegetate. Soak the seeds for twelve hours in water at a temperature of 125°, and then sow them in light soil, placing the pots in a bottom heat of not less than 70°, and not more than 90°. The seeds are best sown in spring, and then the young plants can be forwarded so as to become good plants before autumn. If you sow now it will be necessary to winter the plants in a house where there is a good heat, a light airy position in a stove being most suitable. We remember the time when they were grown as stove plants.

PRODUCE OF FORCED STRAWBERRIES—STEPHANOTIS FLORIBUNDA CULTURE (*Inquirer*).—We have seldom weighed the general produce, but from 3 to 6 ozs. would be a fair average crop for good plants of Strawberries in 6-inch (32-sized) pots, from March to April. Frequently we must be satisfied with less, sometimes we obtain more. Cnt flowers of *Stephanotis floribunda* are generally in demand, but as we have seen the roofs of houses covered with it, we are not so sure of their being the most profitable flowers. It is best trained about 15 inches from the glass, and grown in a large tub or platted out. If a little heat can be given to the roots all the better. We do not think you will do much good with it in any way in a house intended for Vines or Peaches, as these must have a cooler resting period than will suit it. A medium stove heat suits it best.

BORDER OF SPRING-FLOWERING PLANTS (*L. H. M.*).—You do not tell us how your border is surrounded, a matter of some importance. One of the simplest arrangements with seeds for early work would be to sow the diamonds with blue *Nemophila insignis*, and the triangles opposite each other with pink and white *Virginia* Stocks. These would not last long, but they would make a fine display early. If your position is damp, the common, also the alpine *Forget-me-not*, especially the latter, would make a fine display early. We do not undertake to plant beds and borders, we only advise and criticise. Such a border would look well filled with three colours of *Daisies*, also with three colours of *Pansies* or *Heartsease*.

WINIFERING CALADIUMS (*W. L.*).—After the foliage is withered shake out the tubers, and pack them in sand in a box, being careful not to injure the outer skin. They ought not to be packed so closely together as to touch. Keep them in the warmest part of the stove; indeed, they require a winter temperature of from 60° to 65°. They should not be kept dust dry, but are the better of slight moisture, though the soil is to every appearance dry. If you had room we should prefer keeping them in the pots.

APHIS ON CABBAGES (*James Levesque*).—We have found dusting the plants with quicklime very beneficial, and that we are now practising with ours very successfully. Dusting with tobacco powder is more efficacious, and so is sprinkling overhead with tobacco water, that of the

shops being diluted with six times its bulk of water. Various insect-destrory compounds are also used successfully.

MANURING ROSES (A. B. A.).—We should, in November, give a good mulching over the dressing of manure, which may be 2 or 3 inches thick, and a few inches of dry litter would keep all safe from frost. Every winter we have our Rose beds mulched nearly a foot thick, and we never knew an eye decay. In spring remove the loose portion of the litter, and point the manure neatly in with a fork. There is no necessity to go so deep as to interfere with the roots. Liquid manure is very serviceable when plants are growing, but not when the plants are at rest, and is not to be recommended in preference to manure in a solid state. Both are useful.

FORMING RHODODENDRON BEDS (Idem).—The soil where the beds are to be made should be taken out to a depth of 2 feet, and the space filled with the sandy soil and the peat from the meadow in about equal proportions. The peat is best used fresh, but that exposed to the atmosphere during the summer will answer very well. The ground should be drained, for if stagnant water lodge in the soil even American plants, which delight in moisture, will not thrive. The peat should be chopped up, but need not be made very fine.

FORMING A LAWN (Idem).—Turf being scarce, you may sow grass seeds instead. Fill up all holes and take down the hillocks, so as to form an even surface, and dig or trench the ground so as to give the turf or grass seeds a chance of growing, becoming established, and making an uniform growth throughout. For your soil we advise *Festuca duriuscula*, 3 lbs.; *Cynosurus cristatus*, 6 lbs.; *Festuca tenuifolia*, 3 lbs.; *Poa nemoralis*, 2 lbs.; *Poa trivialis*, 2 lbs.; *Festuca ovina*, 4 lbs.; *Lotus corniculatus*, 1 lb.; and *Lolium perenne* tenne, 24 lbs., in mixture for one acre. You may sow this mixture in September, the ground being in good tilth and free of weeds, especially Dock, Dandelion, Plantain, Yarrow, and Couch. The finer the surface the better for the seeds. Roll well after sowing. If the ground is not in good order do not sow until next April. Your Carnation we shall notice next week.

HEATING A SMALL GREENHOUSE (Q. Q.).—Your case is just one of those frequently referred to by Mr. Fish. As the house is 21 feet by 15, one of the best arrangements would be a narrow platform all round, except at the doors, a walk all round, and a platform and stage in the centre. Then you could place your furnace deep enough at the most convenient corner, and take your flue all round, or round three sides, but sunk so that the top of the flue would form part of the pathway. By this mode you would have no difficulty with your doorways, as the flue would be beneath their level. You would have also a pleasant pathway in cold weather. Your having to raise the chimney 8 or 10 feet would make the flue draw all the better. (C. Y. C., *Bedford*).—You do not give us sufficient data, especially as to levels, to enable us to help you. We do not think tank-heating would suit you as to expense, nor yet as to the doorways, as the tanks must be level. Then we have no idea how the level of the chimneys in the hall and the drawing-room agree with the level in the greenhouse. It is very difficult to make heat descend; it has a natural tendency to rise. There are exceptions; for instance, in a large parlour we lately saw an iron stove in the middle of the room with an open grate, but a close bevelled top, and underneath that an opening for the smoke to go down, which it did beneath the floor, and also beneath the floor of a large kitchen, but then the smoke flue terminated in a high kitchen chimney, and the draught was the cause of excess. It was here altogether an exceptional case. It is always expensive to heat such houses as yours, 11 feet by 14 feet, by hot water, if the apparatus has to be erected on purpose. Then there is an objection to a chimney being seen; and, again, there are the doorways in the greenhouse. If in the hall chimney you could fix a little boiler, so that the top of it should be about 6 inches below the level of the floor in the hall, and at least as low as the floor in the greenhouse, then you could cross the floor of the hall under the level, and have the pipes above the floor in the greenhouse, entering on the hall side, going as far as the doorway on the west side, and returning. If you could sink low enough under that hall chimney, you might take a flue from it all round the greenhouse under the floor level, and let it terminate at the chimney above the furnace. Again, if you could make a small furnace outside on the west side near the doorway, you might also have a small flue below the floor level, crossing the hall into the chimney. If none of these suit, the simplest plan would be to have a metal stove, with a flat top to receive an evaporating basin, and take a 4-inch pipe from it outside the roof of the greenhouse. The stove will be rarely wanted from April to the middle of October. Is there an kitchen not so far off on a lower level than the greenhouse, from which you could borrow heat? Level in these matters cannot be disregarded.

MILDEW ON PEAS (Mrs. H. Thring).—The way to prevent Peas becoming mildew, is to give them copious supplies of water.

BERBERIS NOT FLOWERING (Norwood).—The plants will flower as soon as they are old enough, if not interfered with.

DISCOLOR (R. G.).—This word is applied to parts having one surface of one colour, and the other of another colour; also to green altered by a mixture of purple. The leaves of *Cissus discolor* are green mottled with white on the upper surface, and purplish red beneath: hence the application of the word. Tricolor, as applied to variegated zonal Pelargoniums, has before been objected to, but it is sanctioned by use, and generally understood, and the leaves of such Pelargoniums contain three colours in various degrees of intensity.

CABBAGE CATERPILLARS (Subscriber).—Those you complain of appear to be the larvae of *Pontia brassicae*, for which hand-picking is the remedy.

PLANTS FOR EXHIBITION (C. R.).—We should decidedly prefer the Fern.

WASPS.—“J. P. H.” says that he has noticed for years that however abundant wasps are throughout England, it is a very unusual thing to meet with one in the town of Southampton. It cannot be on account of the sea air, as he has noticed in other seaport towns the grocers' and other windows full of wasps at this season.” If Southampton is so exempt, we can assign no valid cause; but we remember the story of Charles II. and the Royal Society.

INSECTS (E. S. P., jun.).—The best seen are *Andrena pilipes*, one of the solitary nest-making species. The smaller ones are the males, which, like all male insects, are destitute of a stung. (J. H.).—Your Cherry leaves are infested with the slimy larvæ of a small black-winged species

of saw-fly, *Selandria æthiops*. They may be killed with dusted lime or lime-water. (E. S., *Liverpool*).—Your Ash trees are attacked by the small and not-uncommon little beetle named *Hylesinus Fraxini*. Its habits are quite like those of the *Scolytus destructor* which attacks the Elm, the female depositing her eggs in the bark, and the young larvæ burrowing into the inner bark. If very numerous the trees might be partially barked, the bark being burnt.—I. O. W.

NAMES OF FRUIT (Sir Percy Burrell).—The Plum is evidently a wilding, and not referable to any cultivated variety.

NAMES OF PLANTS (Château Vallon).—We cannot say exactly what your plant is from the leaf only, but suppose it to be some Anthemoid Composite, some ally of the Feverfew. Cannot you send us a flower? (J. G. S.).—1, *Veronica Teucrium*; 2, 4, 5, 6, *V. longifolia* and its varieties, differing only in colour or variegation; 3, *V. gentianoides variegata*; 3, Some species of *Teucrium*, send when in flower; 7, *Pentstemon glaucum*. (Subscriber).—1, *Rhus Cotinus*; 2, *Hypericum chinense*; 3, *Geranium sanguineum*. (Tyro).—Apparently *Achusa sempervirens*. (Grave).—One of your shrubs (that in fruit) is *Rhamnus Frangula*, the other is very doubtful, probably some *Prunus*; send a better specimen, if possible, in flower or fruit. (A Constant Reader).—1, A narrow-leaved variety of Sweet Bay, *Laurus nobilis*; 2, We suppose it to be some *Acacia*, but do not recognise it. (R. Jameson, *Gargrave*).—*Ornithogalum alliacum* (Short Grass)—*Bromus secalinus*. The idea of its being degenerated Oats is, we find, widely spread, but is utterly unfounded; a like fallacy in supposing *Lolium temulentum* to be degenerated Wheat also prevails. (S. Brierley).—Seeding state of *Pteris aquilina*. (*Amateur*). *Colutea arborescens*.

POULTRY, BEE, AND PIGEON CHRONICLE.

PREVENTION OF FRAUDULENT PRACTICES AT POULTRY AND BIRD SHOWS.

The process of incubation being completed, and the admonition not to study one of the simple rules of arithmetic as applied to poultry being removed, breeders will be legitimately engaged in counting their chickens.

In prospect of the approaching exhibition season, let me take time by the forelock, and call the attention of committees to the importance of legislating on the above question. Much has been said about it, and many suggestions made with a view to putting a stop to the dishonest (there is only one word for it) practices of certain exhibitors. I cannot now refer to the articles, for though I have the index to the last volume of the Journal, unfortunately that is all I have, as I either give away my weekly numbers, or lend them, which amounts to the same in the end. But if my memory serves me correctly, nobody seems to have prescribed a specific for this loathsome form of moral disease, while those who do recommend some mild kind of medicine, either do it as if with a desire not to hurt the sensitive feelings of their patients, or administer it in such a way that its effects are not felt. Cautions and hints are only gentle aperients, and the disease can only be met by strong purgatives.

One correspondent, taking what I think is a correct view of the matter, suggested that action should commence with the committee of management, and said he should hail with satisfaction the appearance of a schedule with atringent rules affecting the subject under consideration. A prize list with regulations worded in general terms, implying that specimens must be shown honestly, is issued, but no special punishment for an infringement of this necessary requirement is attached. On this head all is vague, and in many cases the extreme penalty is the disqualification of the single pen or specimen in the quietest manner possible, not to alarm intending purchasers, and so spoil the market, and when any disagreeable work has to be done, the judge is expected to take it on his shoulders. It is no part of his office. When any case of more than ordinary barefaced impudence occurs, when a manufactured bird appears in borrowed plumes, or minus his surplus plumage, or daubed up to such an extent that the paint “comes off in lumps,” as I once heard it remarked, then comes the cry that the judge ought to do this, and the judge ought to do that, and the judge ought to do the other thing. It is quite a mistake. The judge should do nothing of the sort. It is his duty to award prizes and detect frauds, and nothing else. He has no right even to put “disqualified” on a pen, or as much as to mark with his pencil a card or a label. His awards and remarks should be handed in to the committee, and it is for them to inflict the punishment which the rules say shall be inflicted. Then let the rules be stringent. It is the pusillanimity of committees which alone is to blame for the demoralised state of things existing in our shows unchecked, which allows exhibitors convicted of fraudulent doings still to carry on their nefarious trade in the most unblushing manner, and I grieve to say, that in discussion with men in whom I might have expected to find a higher tone of exhibitionising morality, I have

discovered a mental obliquity most painful to witness, a disposition to shirk the question, and an implicit belief in the shuffling creed, that two wrongs make one right.

I would therefore urge on all committees to revise their rules, or rather those relating to fraudulent practices and the penalties thereunto attaching; and if they be really anxious to root out dishonesty and expunge the names of dishonest men from their catalogues, let them enact such laws as shall be a terror to evil-doers, and which will practically have the effect of driving them from the exhibition field, nailing them up against the gable ends of our catalogues and reports as the stoats and polecats of the hen-roost. It is useless winking at any malpractices, or trying to gloss them over—pull them up by the roots. A time-serving policy is always a self-defeating policy.

In our rules (North of England Ornithological Association, Sunderland), we have the following—"Any bird with clipped, drawn, or artificially coloured plumage shall be excluded, and the owner of such bird shall forfeit all entrance fees, and shall be disqualified from taking a prize at this or any future shows of the Association." We issued this in 1866, and have found it work well. But with the object of still further checking the evil the rule will be made still more comprehensive in its grasp, including all who shall at any time have been convicted of such practices at any public show. The published report of such delinquency, or a notification from an accredited secretary or official authority, will be deemed sufficient reason for such exclusion; while the option of accepting or refusing any entry will enable us to deal very summarily with cases of suspected *bonâ fide* ownership. We shall do this or give up shows entirely, for we will never consent to their existence if connection with chicanery and knavery be the conditions.

The result of my own observation as a judge, and my experience as a breeder, is that perfection (in the department I represent) is in many classes a much scarcer article than is supposed, and exists really in a much less degree than is apparently presented to us at shows. Translate that into plain Saxon. It is to induce an honest exhibition of the nearest approximation to perfection that the legislation of our committees should tend, that we may know when we are looking at any bird that what we see is, and not that it is not.—W. A. BLAKSTON.

TESTIMONIAL TO MR. R. FULTON.

It will be in the recollection of many of your readers that at the exhibition of Pigeons held at Glasgow in December, 1869, when the contest for the grand challenge cup was decided, some birds exhibited by Mr. Fulton were by some unaccountable means transposed to the pens belonging to his principal opponent, who thereby received the points really gained by Mr. Fulton's birds. This, in the opinion of some fanciers, materially affected the position of the competitors, and some of Mr. Fulton's friends being of opinion that the cup should have been finally awarded to him, have, in order to testify to his thoroughly upright conduct, and their opinion he had been somewhat harshly treated, subscribed for and presented to him a duplicate of the original. The cup is of very handsome design, and an exact fac-simile, excepting that the figure of a Pouter on the cover and the stand itself is, as well as the body of the cup, of silver, instead of being plated like the original.

The presentation took place in the presence of several of Mr. Fulton's friends, who warmly congratulated him upon the position he has attained amongst fanciers generally by his strict integrity and straightforward dealings. Amongst the subscribers were Messrs. F. Crossley, G. Ure, F. T. Wiltshire, J. Ford, G. Chapman, and other English and Scotch fanciers.—J. FORD, Treasurer.

CLITHEROE POULTRY SHOW.

The following are the awards made at the above Show, held August 6th:—

GAME.—1 and 2, F. & C. Haworth, Newfield, Haslingden. **COCK.**—1, F. & C. Haworth. 2, Messrs. Eastwood & Hinde, Accrington. *Any other Variety.*—1, F. & C. Haworth. 2, W. Robinson, Clitheroe. 1 and 2, T. Briden, Earby, Skipton. **COCHINS.**—*Buff or Cinnamon.*—1 and 2, T. Seed, Bay-hall Town, Clitheroe. *Any Variety.*—1, G. Anderson, Accrington. 2, H. Smalley, Grindleton, Clitheroe. **SPANISH.**—1, F. & C. Haworth. 2, H. Wilkinson, Earby, Skipton. **BRAMA.**—1, F. & C. Haworth. 2, G. Anderson. **HAMBURGS.**—*Golden-pencilled.*—1, B. Bee, Gossnarth. 2, H. Pickles, jun., Earby, Skipton. *Silver-pencilled.*—1, B. Bee. 2, H. Pickles, jun. *Golden-spangled.*—1, H. Pickles. *Silver-spangled.*—1, H. Pickles. 2, J. Cronshaw, Accrington. **BLACK.**—1, F. & C. Haworth. 2, B. Bee. **POLAND.**—1, H. Pickles. **GREY BANTAMS.**—1, T. Barker, Hill End, Burnley. 2, N. H. Ellis, Accrington. **COCK.**—1, Harwood & Buckley, Accrington. 2, Bellingham & Gill, Burnley. **TRUMPETERS.**—1, J. Houlker, Blackburn. **GESE.**—1, J. Houlker. 2, T. Bank, Waddington.

DUCKS.—*Aylesbury.*—1, H. Deane, Whalley. 2, J. Snaith, Clitheroe. *Rouen.*—1, J. Houlker. *Any Variety.*—1, F. & C. Haworth.

PIGEONS.

CARRIERS.—1, L. Byrom, Blackburn. 2, J. Ashworth, Blackburn. **TUMBLERS.**—1 and 2, Bellingham & Gill, Burnley. **BARBS.**—1 and 2, J. Hamilton, Haslingden. **OWLS.**—1, W. Buckley, Blackburn. 2, J. W. Brade, Blackburn. **POUTERS OR CROPPERS.**—1, Bellingham & Gill. **FAN-TAILS.**—1 and 2, J. Kemp, Haslingden. **TURKITS.**—1, J. Kemp. 2, F. Moore, Burnley. **DRAGONS.**—1 and 2, J. Ashworth. **TRUMPETERS.**—1 and 2, Bellingham & Gill. **ANY OTHER VARIETY.**—1, Bellingham & Gill. 2, J. Hiley, Accrington.

RABBITS.—*Spanish.*—1, J. Boyle, jun., Blackburn. 2, J. Irving, Park Gates, Blackburn. *Any other Variety.*—1, J. Boyle, jun. (Silver-Grey). 2, A. L. Lawstron, Haslingden (Himalayan).

JUDGES.—Mr. T. Wareing, of Preston, and Mr. Thompson, of Halifax.

(From a Correspondent.)

THE Rabbits were quite a success, considering there were only two classes, and that the prizes were so small, the first prize being only 10s., the second 5s. The first prize was awarded to a Black and White buck belonging to Mr. Boyle, jun., a very fine specimen; the second prize to a Tortoiseshell buck belonging to Mr. J. Irving, a first-class Rabbit, but in poor condition. There were five pens in this class, and some really good Lops. The "Any other variety" class had nine entries, and all but one put in an appearance. The first prize was awarded to Mr. Boyle's Silver-Grey buck, decidedly the best in the class, a beautifully silvered Rabbit. The second prize went to a Himalayan buck, very dark in all points, but spoiled with a white streak on his nose, a fine Rabbit but for that fault.

Taking the Rabbits on the whole there was a first-class show, which ought to encourage the Committee to offer at least four classes for the future. The management was anything but good; part of the Rabbit pens were among the cats, and the other part among the Pigeons, 20 yards off. They were viewed by crowds of people throughout the day.

ALLERTON POULTRY SHOW.

THIS Show, which has attained a leading position among the Yorkshire exhibitions, was held on the 6th inst., and was a complete success as regards arrangements, number of entries, and number of visitors. The poultry pens were arranged in a square with the Pigeon pens along the centre. The pens were from Turner, and were purchased for the occasion; their appearance was very pretty.

Many of the adult *Game* were much out of feather, but the pen to which the cup was given was in good bloom and consisted of Brown Reds. *Spanish* were good, but not numerous. The first-prize *Cochins* were White, and of excellent quality. *Polands* were very fine, and the *French* fowls unusually good. The single *Hamburgh* cocks were in full plumage, and excellent in marking. The cup for *Hamburghs* was won by Golden-pencilled of extraordinary colour and quality for the time of year. The *Bantam* classes were not well filled, but there were some well-shaped birds.

The chickens were scarcely so numerous as we have seen them at this Show, and were as a rule rather backward in feather. This remark applies particularly to the *Game* classes. The *Hamburghs* were the best classes of young birds, although Mr. Sidwick sent two excellent pens of *Cochins*; the first prize birds were *Buffs*, and the second-prize birds *Partridge*. The first-prize *Black Red Game* cockerel was of extraordinary quality, but the second-prize bird was most decidedly one of last year.

Of *Pigeons* there were some excellent birds. Mr. Hawley had the best position for *Pouters*, and Mr. Horner for *Carriers*. The first-prize *Red Mottled Tumblers* were little gems, and the second-prize *Almonds* also good in point of feather. The *Turkit* class was large, and many more prizes might have been given to deserving pens. The first prize went to *Blacks* of perfect colour, the second to *Blues*, and the third to *Reds*. *Jacobins* were *Red* and *Black*, the latter losing only in the length of face. *Fan-tails* were moderately good, but the first-prize pair rather dirty. The *Barb* class contained such birds as are rarely seen, though some of those left out of the prize list were exceedingly high in colour of eye wattle. The *Trumpeters* were good, the *Nans* neat, and the *Antwerps* the most extraordinary class; five prizes were awarded and several high commendations. In *Magpies* the birds were most beautiful in colour and marking, though we regret to say that one of the principal exhibitors did not scruple to exhibit his expertness in the trimming department before the very eyes of the public. In the "Any other Variety" class the first were *Porcelain Swallows*, the second *Reds*, and the third a fine pair of *Silver Runts*. In the *Selling* Class the winners were a splendid pair of pure *Silver Dragons*, *Red Barbs*, and *Black Trumpeters*.

There were some excellent *Rabbits*, the best of which were, however, left out on account of only one being sent in place of pairs. The cup offered to the exhibitor of Pigeons gaining the greatest value in prizes was won by Mr. J. Hawley, of Bingley.

GAME.—*Cock.*—1, E. Aykroyd, Eccleshill. 2, W. Bentley, Allerton. 3, E. Wood, Worcester. *Hen.*—1, J. Hodgson, Bradford. 2, J. Spencer, Clayton. 3, R. C. & W. J. Mason, Drighlington. *hc.* W. Spencer, Haworth; E. Aykroyd. **RED**—1 and Cup, E. Aykroyd. 2, J. Sunderland, Halifax. *Any other Variety.*—1, H. Jowett, Idle. 2, E. Aykroyd. 3, J. Sunderland. **SPANISH** (Black)—1 and 2, H. Beldon, Gofstock. 3, J. Powell, Bradford. **COCHIN-CHINA.**—1, J. Siebel, Timperley. 2, H. Beldon. 3, J. H. Dawes, Birmingham. *hc.* G. Fletcher, Didsbury. **POLANDS.**—1, 2, and 3, H. Beldon. **DORINGS.**—1, Hon. H. Fitzwilliam, Wentworth Woodhouse. **BRAMA** **POULTRY.**—1, W. Whiteley

Sheffield. 2 E. Leech, Rochdale. 3 J. Siebel. *hc*, H. Beldon. *FRENCH FOWLS*.—1, H. Beldon. 2, Hon. C. W. Fitzwilliam. 3, Hon. H. W. Fitzwilliam. *hc*, J. J. Malden, Biggleswade. *HAMBURGERS*.—*Cocks*.—1, H. Beldon. 2, W. Driver, Keighley. 3, A. Driver, Keighley. *hc*, H. Beldon. *H. PICLES*, jun. *Gold-pencilled*.—1, G. E. Newton. 2, H. Beldon. *hc*, H. Picles, jun. 2, H. Picles, jun. *Silver-spangled*.—1 and 3, H. Beldon. 2 and 4, *hc*, H. Picles, jun. *Gold-pencilled*.—1, 3, and Cup, H. Beldon. 2, H. Picles, jun. *Silver-pencilled*.—1 and *hc*, H. Picles, jun. 2 and 3, H. Beldon. *Black*.—1, H. Beldon. 2, H. W. Hingworth, Idle, near Leeds. 3, T. Walker, Denton, near Manchester. *hc*, H. W. Hingworth. C. Sidgwick, Ryddlesden Hall, Keighley. *BANTAMS*.—*Game*.—Cup, W. F. Entwisle. 2, G. Noble, Staincliffe, Dewsbury. *Cock*.—1, W. F. Entwisle, Westfield, near Cleckheaton. 2, W. Bravay, Bradford. 3, W. Bailey, Greenfield, near Halifax. *Game*, *any other Variety*.—1, W. F. Entwisle. *Any other Variety*.—1, J. Walker, Halifax. 2, J. W. Cannon, Bradford. 3, J. Pearson, Hill Top, Allerton. *hc*, H. Beldon. 3 and R. Ashton, Mottram, Cheshire. *ANY OTHER VARIETY*.—1, R. Loft, Woodmans, near Beverley. *DUCKS*.—*Roan*.—1, E. Leech. 2, J. Crosland, Huddersfield. 3, W. Bentley, Greasdale, Allerton. *hc*, J. White, Whitby, Netherton. *Any other Variety*.—1, E. Leech. 2, W. Willing, Farhill, Kildwick. *Ducklings*.—1 and 2, E. Leech. 3, J. Dove. *SELLING CLASS*.—1, J. J. Booth, Silsden. 2, J. Bailey, Earsby. 3, R. Loft. *hc*, H. Beldon. c, J. Berry, Silsden.

CHICKENS.

GAME.—*Cockerel*.—1, J. Carlisle, Earsby. 2, J. Mason, Worcester. 3, T. Dyson, Halifax. *hc*, J. Fortune. E. Lund, Morton Banks. *Pullet*.—1, J. Carlisle. 2, J. Harker, Heaton. 3, W. H. Green, Queensbury. *hc*, W. Spencer, Haworth; J. Pearson, Allerton; H. C. & W. J. Mason. c, W. Drake, Allerton. *Red*.—1, W. Spencer. 2, J. Brown. 3, J. Smith. *Any other Variety*.—1, M. Jowett, Clayton. 2, J. Mitchell, Birmingham. 3, H. Jowett. *COCHIN*.—1 and 2, C. Sidgwick, Keighley. 3, J. Dove, Moulton. *HAMBURGERS*.—*Gold-spangled*.—1, J. Andrew, Ashton-under-Lyne. 2, W. Driver. 3, T. Walker. *Silver-spangled*.—1, H. Beldon, Bingley. 2, H. Picles, jun. 3, J. Rhodes, Harden. *hc*, C. Smith. *Gold-pencilled*.—1, H. Picles, jun. 2, H. Beldon. 3, T. Wrigley, jun., Tongre Hall, Middleton. *Silver-pencilled*.—1, H. Beldon. 2 and 3, H. Picles, *hc*, H. Picles; T. Hanson, Keighley. c, T. Hanson. *Black*.—1, J. Cockerell, Keighley. 2 and 3, C. Sidgwick. *BANTAMS*.—*Game*.—1, W. F. Entwisle. 2 and *hc*, F. Steel, Halifax. 3, G. Noble, Staincliffe. *Any other Variety*.—1, H. Beldon. 2, T. Dyson. 3, W. F. Entwisle. *hc*, S. and R. Ashton, Mottram; W. Clayton.

PIGEONS.

POUTERS OR CROPPERS.—1 and 2, J. Hawley, Bingley. 3, J. T. Lishman, Gillington. *CARRIERS*.—1, 2, and 3, E. Horner, Harewood. c, S. Smith, Idle. *TUMBLERS*.—*Short-faced*.—1 and 3, J. Hawley. 2, E. Horner. *hc*, F. Graham, Birkenhead. *Any other Variety*.—1 and 2, J. Hawley. 3, E. Horner. *hc*, Clayton and Birstow. *GIRLINGTON OWLS*.—1, H. Yardley, Birmingham. 2, J. W. Cannon, Bradford. 3, J. Hawley. *hc*, J. Hawley; S. Smith, Idle; E. Horner. *TURBITS*.—1, E. Horner. 2, A. Child, Idle. 3, Foster, Pennington Gate. *hc*, E. Hingworth, Allerton. c, C. Sazden, Wilsden; E. Horner. *JACOBS*.—1 and 2, J. Hawley. 3, J. W. Cannon. *hc*, J. T. Lishman; J. Crosland; E. Horner. *FANTAILS*.—1, H. Yardley. 2, E. Horner. 3, C. Sazden. *hc*, J. Hawley; E. Horner. c, F. Graham. *BARDS*.—1, E. Horner. 2, J. W. Cannon. 3, H. Yardley. *hc*, J. Crosland. *DRAGONS*.—1 and 2, F. Graham. 3, J. Hawley, Bingley. c, J. T. Lishman; J. Hawley. *TRUMPETERS*.—1, J. Hawley. 2, E. Horner. 3, J. Crosland. *NEWS*.—1, F. Graham. 2 and 3, H. Yardley. *hc*, J. T. Lishman. *ANTWEERS*.—1, J. P. Lishman. 2, E. Horner. 3, J. Hawley. c, J. Crosland. 5, W. Lund, Shipley. *hc*, J. A. Collinson, Halifax; J. Hawley. J. Oldroyd, Wakefield; R. Sidgwick; Clayton & Birstow; E. Horner. *MAGPIES*.—1 and 2, J. T. Lishman. 3, E. Horner. *hc*, A. H. Easton, Hull; J. Crosland; E. Horner. 2, 3. *ARCHANGELS*.—1, H. Yardley. 2, E. Horner. 3, S. Smith. *ANY OTHER VARIETY*.—1, J. T. Lishman. 2, E. Horner. 3, S. Smith. *hc*, H. Yardley; J. T. Lishman; J. Hawley; E. Horner. *SELLING CLASS*.—1, Clayton and Birstow. 2, J. Hawley. 3, Sazden. *hc*, J. T. Lishman (2); E. Horner; W. B. von Haansbergen, Newcastle-on-Tyne. c, J. T. Lishman.

RABBITS.—*Long-eared*.—1, C. Gravel, Thorne. *Any other Distinct Breed*.—1, T. M. Corbridge, Bradford. 2, A. Preston, Allerton. 3, H. G. Pool, Bradford. *Common*.—1, J. Knight, Allerton. 2, H. Dixon, Allerton. 3, L. Leech, Allerton.

JUDGES.—*Poultry*: Mr. J. Dixon, Bradford, and Mr. R. Teebay, Fulwood. *Pigeons*: Mr. E. Hutton, Padsey.

MORLEY POULTRY SHOW.

THIS was held on the 5th and 6th inst. The *Game*, *Geese*, and *Rouen Ducks* were very good. The first-prize pen of *Golden-pencilled* was by far the best of those shown in the *Hanburgh* classes. Of *Pigeons* there was a good show.

SPANISH.—1 and Cup, C. W. Brierley, Middleton. 2, J. Thresh, Bradford. *DORINGS*.—1, J. White, Northallerton. *BRAMA POOTRAS*.—*Dark*.—1, E. Leech, Rochdale. 2, W. Whitley, Sheffield. *GAME*.—*Black-breasted Reds*.—1, R. Hemingway, Halifax. 2, W. Fell, Adwalton. *Brown-breasted or other Reds*.—1 and Cup, C. W. Brierley. 2, W. Fell. *Duckings or other Greys or Blues*.—1, J. Lamington, Spalding. 2, H. C. Mason, Drighlington. *Any other Variety*.—1, T. and C. Mason. 2, R. and H. Walker. *Cock*.—1, C. W. Brierley. 2, H. Beeland, Bradford. 3, W. Fell. *Hen*.—1, H. Beeland. 2, J. Fell. *hc*, C. W. Brierley. *HAMBURGERS*.—*Gold-spangled*.—1 and 2, J. J. Rollinson. *Silver-spangled*.—1, H. Picles, jun., Earsby. 2, R. Barren, Morley. *Gold-pencilled*.—1 and Cup, S. Smith, Northowram. 2, W. Hingworth, Idle. *Black*.—1 and 2, W. Hingworth. *BANTAMS*.—*Game*.—1, J. J. Rollinson. 2 and *hc*, F. Steel, Halifax. *Black*.—1, S. and R. Ashton, Mottram. 2, W. Hingworth. *Any other Variety*.—1, W. Whitley. 2, S. and R. Ashton. *SELLING CLASS*.—1, C. W. Brierley. 2, J. Fell. *GEESE*.—1, E. Leech. 2, J. White. *DUCKS*.—*Roan*.—1, E. Leech. 2, J. White. *Aylesbury*.—1, E. Leech. *Any other Variety*.—1, C. W. Brierley. 2, S. and R. Ashton.

PIGEONS.

CARRIERS.—1, H. Yardley. 2, E. Horner, Harewood. *OWLS*.—1, J. Thresh. *TURBITS*.—1, E. Horner. 2, H. Yardley. *BARDS*.—1, H. Yardley. 2, E. Horner. *TUMBLERS*.—1, H. Yardley. 2, C. Anton. *FANTAILS*.—1, H. Yardley. 2, E. Horner. *POUTERS*.—1 and 2, E. Horner. *JACOBS*.—1 and 2, E. Horner. *TRUMPETERS*.—1, J. Thresh. 2, C. Anton. *ANTWEERS*.—1, C. Anton. 2, E. Horner. *ANY OTHER VARIETY*.—1, E. Horner. 2, C. Anton.

JUDGE.—Mr. John Crosland, jun., Wakefield.

ROYAL AGRICULTURAL SOCIETY'S (OF IRELAND) POULTRY SHOW.

THIS was held at Ballinasloe on the 3rd, 4th, and 5th inst., and the following awards were made:—

DORINGS.—*Silver-Greys*.—1 and 2, Mrs. Warburton, Kill, Naas. *Chickens*.—1, W. Magrath. 2, Mrs. Warburton. *Chickens*.—1, R. P. Williams. *Coloured*.—1 and 2, Mrs. Warburton. *Chickens*.—1, J. C. Cooper. *Limerick*. 2, Mrs. Warburton. *SPANISH*.—1, S. Mowbray, Mountath. 2, R. P. Williams. c, J. C. Cooper. *Chickens*.—1, S. Mowbray. 2, R. P. Williams. c, J. C. Cooper.

BRAMA POOTRA.—1 and 2, Mrs. Warburton. *Chickens*.—1, J. C. Cooper. 2, Mrs. Warburton. *COCHINS*.—*Buff*.—1, J. C. Cooper. 2, Mrs. Taaffe. *Chickens*.—1, Mrs. Taaffe. 2, J. C. Cooper. *Other colours*.—1 and 2, Mrs. Taaffe (Black and Partridge). *hc*, R. P. Williams (Partridge). *Chickens*.—1, R. P. Williams (Partridge). *Chickens*.—1, S. Mowbray. 2, J. C. Cooper. *Bards*.—1 and 2, J. Hyland, Dublin. *GEESE*.—1, Mrs. Warburton. 2, R. P. Williams. 3, J. C. Cooper. *hc*, S. Mowbray. c, R. Bowman. *DUCKS*.—*Aylesbury*.—1 and 2, R. P. Williams. *Roan*.—1 and *hc*, R. P. Williams. 2, J. C. Cooper.

JUDGES.—Mr. C. F. Stanton, Cappagh, Clonda Ikin; Mr. W. G. Merry, Blesington, Co. Wicklow.

FULFORD POULTRY SHOW.

THIS Show was held on the 1st inst. The entries were not numerous, but the quality of the birds was good. The *Spanish*, *Dorkings*, *Hamburghs*, *Ducks*, *Geese*, and *Turkeys* were all that could be desired.

SPANISH.—1, W. Bearpark, Ainderby Steeple. 2, E. Thackray. *DORING* (Any variety).—1 and Extra for best pen, W. Bearpark. 2, Rev. G. Huster, Stillingfleet, York. *GAME* (Any variety).—1, C. Triffitt, Cattel. 2. — Mollett. *HAMBURGH*.—*Gold-spangled or pencilled*.—1, W. Bearpark (Spangled). 2. — Mollett (Pencilled). *hc*. — Crummack, Fulford. *Silver-spangled or Pencilled*.—1, W. Bearpark. 2. — Lazenby, Escrick. *hc*, W. Croft, Lendal. *BARNDOOR* (Any cross breed of fowls, Bantams excepted).—1, J. Hatfield, Oshaldwick. 2, Rev. G. Huster. *hc*. — Lazenby. *CHICKENS* (Any variety).—1, Rev. G. Huster. 2. — Tasker, Naburn. *BANTAMS* (Any variety).—1. — Lazenby. 2, G. Hutchinson. *hc*, T. Wheatley; A. S. Perfect, Fulford. c, J. Jackson, Heworth; Miss G. Cattle, Bishopthorpe. *ANY VARIETY*.—1, W. Bearpark. 2 and *hc*, C. Triffitt. c, S. A. Webster. *GEESE* (Any variety).—1, Rev. G. Huster. 2, J. Harrison. *TURKEY* (Any variety).—1, Rev. G. Huster. 2, A. S. Perfect. *DUCKS* (Any variety).—1, Rev. G. Huster. 2, A. S. Perfect.

CAGE BIRDS.

CANARY.—*Belgian*, *Yellow*.—1 and 2, J. Baines, Little Shambles. *Belgian*, *Buff*.—1, J. Baines. *Yellow half-bred*.—1. — Bradbury, Dringhouses. 2, J. Calvert, Bootham. *Buff half-bred*.—1. — Bradbury. 3, J. Calvert. *Yellow Common*.—1 and 2, C. Burton. *Common*.—1, C. Burton. 2. — Bradbury. *any Breed* (Marked).—1, J. Calvert. 2, C. Burton. *Crested*.—1, J. Calvert. 2. — Mollett. *Cinnamon* (Yellow or Buff).—1 and 2, J. Baines. *Lizard* (Gold or Silver-spangled).—1, J. Baines. 2, C. Burton. *Male* (Marked).—1, Mrs. Kirkew, Warthill. 2, C. Burton. *REDCAP*.—1, J. Calvert. 2, Mrs. Kirkew. *PARROT*.—1, J. Calvert. 2. — Hill. *CAVE OF BRITISH BIRDS* (Canaries excepted).—1, J. Calvert. *TURTLE AND RING DOVES*.—1, W. Kirby.

CANARY.—*Lopecared*.—1, W. Ellison, Skeldergate. *Any other Variety*.—1, J. W. Hunter. 2, C. Wooltons.

JUDGES.—*Poultry*: Mr. Coates, Escrick. *Cage Birds*: Mr. Cooper, York. *Rabbits*: Mr. M. Millington.

FOOD FOR PIGEONS.

ALL breeders of fancy Pigeons know that it is absolutely necessary during the breeding season to add a little wheat to the usual food given at each meal. I refer more particularly to the feeding of such stocks as are kept in confinement. Some old birds feed more greedily upon wheat than others, and consequently give their young ones a large portion of that grain. When this is the case it is the means, as a rule, of causing a purging or scouring in the young ones, keeping their nests wet and dirty, retarding the development of their plumage, and preventing them from thriving as they would otherwise do. The antidote I have used for this is a few tick beans put over the throats of the nestlings every evening till the purging is stopped. No Pigeons are more liable to purging from an over quantity of wheat than young Pouters, and there are none so liable to go wrong from being handled while in the nest. Without great care many lose the power of their limbs, and excessive purging also causes this.

A few weeks ago, while looking over a grain merchant's samples, I came upon a bag of rye, which I ordered as a substitute for wheat. My birds seem to like it as well as wheat, and having at the time young ones of all ages, from one day to flying point, this (to me) new summer food has proved so far a success, as I have not, since its introduction, had one case of purging among my birds. It has, so far, been the means of saving time and trouble to myself, and also of allowing the old birds to pass out of and into their nests with comfort. Rye is cheaper than wheat, a matter of importance now-a-days; but should it be proved that it does not cause purging, as wheat is so apt to do, it will be of great importance, as many valuable young Pouters may be saved.

Should any of our friends have tried this grain or feel inclined to try it, their remarks on its effects as a feeding article will be of consequence. It is little things, often the very little things, on which our success in these matters depends.—J. HULL.

THE ALMOND TUMBLER.

[THE following minute and excellent article is from the pen of Mr. Thos. Hallam, of the Birmingham Columbarian Society, which Society has also supplied the engraving.]

In accompanying our illustration of a standard Almond with a description of this, in the opinion of many, the most beautiful of our fancy Pigeons, which, as well as the Carrier and

the Pouter, is an indigenous variety that the fanciers of this country may well feel proud of, it may be as well, perhaps, to preface our remarks by stating that our aim on the present occasion is not to set up any new standard or to improve upon any of the properties which have long ago been established. We merely hope, by the help of the accompanying exquisite picture, and by setting forth the points of the variety in question briefly and lucidly before the readers of this Journal, by pointing out its beauties, and perhaps touching a little on that bugbear which no doubt deters many from entering the fancy—the difficulty of breeding—to be able to enlarge the circle, not of the admirers of the Almond, for every one, whether in the fancy or not, admires its pretty form, its jaunty step, and wonderful diversity of colour, but the circle of its cultivators; in short, to induce more gentlemen to enter into this engrossing fancy, and not to leave it, as at present, in the hands of but a few.

Further improvement we do not think it is possible to make upon the best strains; the utmost limit having been reached. But the majority of the birds we meet with, especially out of the neighbourhood of the metropolis, are sadly in want of some improvement, particularly in head, beak, and carriage; and we cannot but express the hope that our present contribution to "our Journal" may be instrumental in some slight degree in bringing about this desirable end. We should much like to see this lovely variety in greater force at our exhibitions; to see some of the gems which we know are in the possession of a few private fanciers who never dream of exhibiting; to see them with their beautiful plumage all fresh and glossy from their own lofts, instead of the jaded and in many cases worn-out birds which make their appearance merely for trade, and which are bundled from one exhibition to another till death happily puts an end to their miserable existence. We are, however, well aware of the uselessness of setting our anticipations too steadfastly on a pleasure which we fear will never be realised, at least while exhibitions continue open so long as at Bingley Hall, standard Almond Tumblers so valuable, and the prizes (we are not complaining), so inadequate to the risk incurred.

But to return to the more immediate object of this notice. In giving a description of the five acknowledged properties of the Almond Tumbler, we are well aware that we are touching upon a delicate subject. It is a well-known fact that even our first fanciers and judges cannot agree amongst themselves as to which property of the five is of the greatest importance. Some claim colour, others head and beak, and some are for shape and carriage. In offering our opinion upon this contested point we merely state what we as a society are guided by, without in the slightest degree hoping, after so long a period of indecision, that our opinion will come to be the generally acknowledged one. It has been argued that the great difficulty of attaining and maintaining the true standard feather of the Almond should not only cause that to occupy the first position, but to rank equal to three of the other properties. But we would respectfully urge that this difficulty exists only in connection with the high-class head-and-beak birds—that is, getting both head and colour together. It is well-known that among the coarse common birds some of the loveliest colours are not only easily got, but just as easily kept. In fact, there is not the slightest difficulty in breeding to standard for feather in that class. We may, perhaps, be allowed to ask the practical question, "Which of the properties imparts the greatest value to a bird intrinsically, setting aside all questions of individual taste?" and we have every confidence that the answer from the majority of fanciers who really know what Almonds are, would be, "head and beak." However beautiful birds may be in feather, and combining, as we have known instances, a good carriage as well, if they want the head and beak—that is, if they are moneys and coarse—a few shillings is the most which can be obtained for them. Generally, and we speak from experience, the difficulty is to get rid of them at all. On the contrary, however, for first-class head-and-beak birds, whatever may be their colour, whether Kite, Agate, Whole-feather, or Splash, a ready market is always at hand, with good prices, and sometimes such fabulous ones as would astonish many an uninitiated person. Fifteen pounds have been refused for Kites and Agates, and we have even known their weight in sovereigns offered and refused for a pair which it was well known would not breed. How much would have been offered for them with bad heads and beaks, but maintaining every other point they possessed? We leave the question to the decision of the fancy, merely repeating that the property or properties which intrinsically lend the greatest value to a

bird are, in our opinion, the most important. We are not particularly anxious about this matter, neither do we wish to thrust our opinion upon those who do not agree with us; but believing we are right, and that the majority of the fancy who are competent to judge are with us, we shall mention the properties of the standard Almond in the following order—viz., head, beak, eye, shape and carriage, feather, and leave our readers to the Englishman's privilege as to what they will make up their minds to breed for.

The head of the Almond Tumbler should be round, broad, and high. The forehead especially should be broad and prominent, the feathers rising perpendicularly from the nostril, and the more they give the appearance to the bird of the forehead overhanging the beak the greater will be its value. This is, of course, when looking at a bird in its natural position; but the actual skull of the bird denuded of its feathers, or when they are pressed down with the finger, should form the half of a circle—that is, drawing a line from the centre of the nose wattle to the back of the head. A head such as we have described possesses what is termed by the fancy a good "stop," and is the very opposite to the term "moussey," which means a low, narrow skull, tapering gradually and in a point to the bill. This latter is, in our opinion, the greatest defect a bird can have. The feathers running from the lower jaw round to and covering the ears should be full, prominent, and slightly curving upwards, as shown in the present. This feature adds very much to the appearance of the head, and its technical term is "muffy."

In speaking of the beak, we shall not attempt to describe the points of difference between what are termed the Goldfinch, Canary, or other beaks, or instance half an oat or barleycorn as a simile. Such guides are at the best merely ambiguous ones, and point out nothing definite to the young fancier. We shall simply say the beak should be as short, straight, and fine as possible; and the smaller the nose wattle is the better. It has been said that it should be so fine as merely to resemble a white thread drawn across the roots of the feathers; but we do not wish to cut the matter so fine as this, because, for various natural reasons, we do not think it is to be obtained. On the other hand, we would deprecate anything in the way of a large and coarse wattle. It has also been urged that the beak should be white; but this, again, cannot be depended upon, as it is always affected very much by the colour and age of the bird.

The eye should be a clear pearl, large, bright, and prominent, and should be in the centre of the head. If possible, no cere or lash should be perceptible, and the feathers should grow close up to the edge.

The shape and carriage of the Almond are generally taken as one property, and as such is one of the greatest recommendations a bird can have in the eyes of a true fancier, especially for purposes of breeding. Such property at once indicates a well-bred bird. The smaller a bird is the better, the beauty of the other properties being thereby greatly enhanced. It should be short in body, flight, and tail; the legs short, and the feet small. The neck should also be short, and thin immediately around the throat, curving gracefully and imperceptibly into the chest, which should be full, broad, and prominent. In position the bird should stand erect with the head thrown back, so as to be in a direct perpendicular line above the feet; the chest held well up, showing its great prominence between the butts of the wings. A low chest is a great disfigurement to the proper carriage, and is what is termed "goose-breasted." The tip of the tail should just touch the ground. The flight feathers should be carried drooping below the tail, showing their colours to greater advantage, and clearly developing the rump, which should be well covered with feathers, and nicely curved. A bird in the above position should stand entirely on its toes, the ball of the foot being slightly raised from the ground. Of course an Almond Tumbler is not always to be seen in this position, any more than the Carrier or Pouter are constantly in the positions in which they are invariably portrayed; but if a bird has any pretensions at all to a good shape and carriage, whether cock or hen, it will be seen in all its beauty during the time the cock is driving to nest.

In speaking of colour, we must confess we are troubled by the difficulty with which all writers on this subject have had to contend—that is, the want of a suitable term adequately to express what the proper ground colour of the bird should be. The term most in use, and which seems to us the best for the purpose, is to call it a bright "Almond Yellow"—that is, that it should as nearly as possible resemble the colour on

the inside of the shell of the almond nut. Having this as the ground colour, the whole of the body should be neatly and evenly pencilled, not splashed or spangled, with a clear black. This should be the case particularly on the neck and rump. Each feather in the flights and tail should be evenly and distinctly broken with the three colours—black, white, and the yellow or ground colour. The feathers should be tight and compact, and a bright glossy hue overspread the whole of the body, the beautiful effect of which, when the bird stands in a ray of sunlight, can readily be imagined. We have omitted to state that any tinge of blue about the tail, or, in fact, on any part of the bird, is very detrimental, at once showing that it is not well bred. The hen should be similar to the cock in every respect, due allowances, of course, being made for the sex; the hen in every variety being never so bold in appearance, and always more delicate in structure than the cock bird. The great and insurmountable difficulty, however, with the Almond Tumbler hen is to get the proper ground colour sufficiently broken. A hen up to the standard in all points would realise a small fortune.

Whilst upon the subject of feather, it will be perhaps as well to notice the great variety in colour that is produced by these birds, such as Kites, Duns, Red and Yellow Whole-feather,

Splashes, and Agates, the latter term being applied to all birds which have the red or yellow feather more or less intermingled with white, after the manner of what are known as Gay Mottles. Kites are black birds, with a brilliant metallic lustre pervading the feather; and the flight and tail feathers are tinged with red or yellow, which is termed "Fiery." These birds generally run better in head and beak than the Almonds, and are most useful for breeding purposes. In fact, it is totally impossible without them to maintain strength of feather. Splashes generally run very light in the ground colour, with the black very considerably and unevenly intermixed. These birds, especially the hens, are also most valuable for obtaining a good break of feather. Birds of nearly all the above varieties of colour now make their appearance with success in the "Shortfaced, any variety," class at most of our large exhibitions.

In conclusion, although we have already been far too lengthy in our notice, we should like to add a few words in reference to breeding. We firmly believe that a false impression exists respecting the great delicacy of these birds, and the difficulty, nay, almost impossibility, of raising progeny from them. We wish distinctly to state, more particularly for the encouragement of those who otherwise have an inclination to enter the fancy,

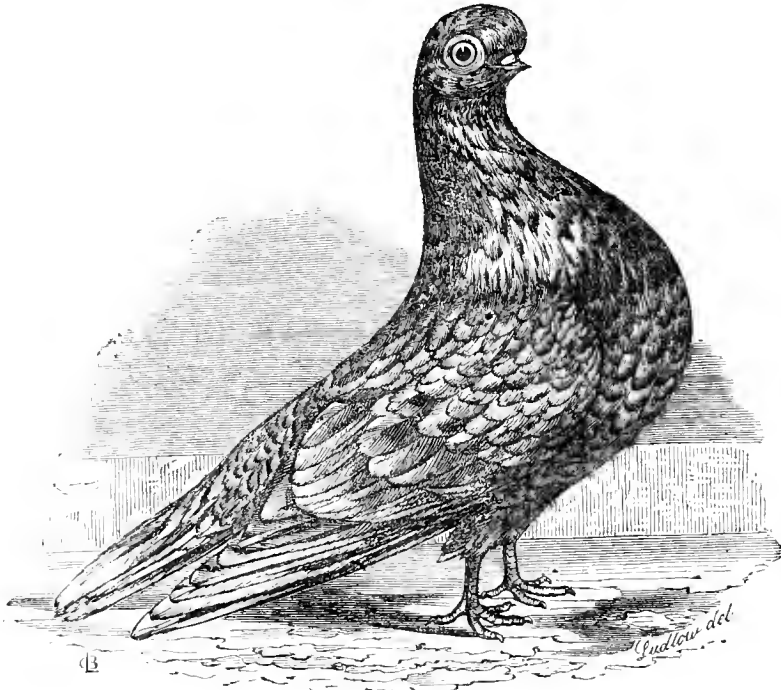

that all such fears are groundless. The birds are, or should be, as robust as any variety of fancy Pigeon we have; and in illustration of this we may perhaps be allowed to state that a member of the Birmingham Columbarian Society kept a few of these birds in an open aviary, certainly with a southerly frontage, for a space of eight or nine years winter and summer, without any other protection from the weather than the roof, and no birds could possibly be healthier than they were, having during the time never had the slightest ailment. We also know on reliable authority of a collection of fancy Pigeons of all kinds being sent to Canada, and all, we believe, with the exception of the Almonds, succumbing to the rigorous winter which followed. And these were birds of the highest quality as to standard properties. With regard to breeding, a little more attention is no doubt required for the Almond than for other varieties. This is particularly the case at the times of hatching, and shifting the young under the feeders; but this little extra attention, instead of being a trouble, is rather a pleasure to the ardent fancier. For the information of would-be fanciers, we will give a simple plan in regard to breeding which has been found not only effective, but remarkably successful. The first and most important matter in Almond breeding is properly matching the birds; and on the fancier's knowledge of this

much of his success will depend. No precise rule can be laid down; nevertheless a few practical suggestions may be given. A Kite may be matched to almost anything but a Kite, such as an Almond, light Splash (that is, a bird with not too much black), Red or Yellow Agate or Whole-feather; but of all, the best, in our opinion, is the match of a Splash and a Red or Yellow Agate—the Red preferred. It is well not to match the birds too rich in feather, especially if close bred, or white and purblind birds will be the result. Experience and a knowledge of how the birds are bred are everything in this matter; and even then no certainty as to the colour of the offspring can be depended upon. It is a fact that birds which one year have thrown the most beautiful Almonds, have the next season produced nothing but Kites. A great advantage in this variety is the extent to which they can be bred in, not only improving them in character, but avoiding that nuisance to all breeders of other birds, especially the Carrier and the Ponter, of the necessity of finding and purchasing suitable crosses. Almonds as a rule are very prolific; and to insure a fair amount of success all that is required is a little attention at the right moment.

A staff of nurses is an indispensable requisite to the Almond breeder. For this purpose the common Baldheads are the best, and of these what are called the "pleasant-faced" ones—that

is, not too long in the bill, are to be preferred. It is well to keep as many of these as the fancier conveniently can, for when not rearing Almonds their young ones will find a ready sale at prices which will render their keeping profitable. And now for the simple plan to which we have alluded. When the first egg is laid remove it to some safe place (a little box of bran, or elsewhere) substituting an added one. Replace the good egg about 9 A.M. on the third day. This prevents the birds commencing to sit on the first egg, which is very often the case, and ensures both birds being hatched together. Keep a diary of the date on which the eggs should hatch; and on that day be ready, should occasion require it, to help any young bird to extricate itself from the shell, as it often happens, either from weakness or excessive shortness in bill, they are unable to extricate themselves. Do not be in too great a hurry to break the shell; and above all, abstain from doing so till all the blood in the shell is absorbed. It is often the case that a young bird is so fine in the bill or so weak that the old birds are unable to give it food, and it dies in consequence. If either of the young birds are not fed towards the evening of the day on which they are hatched, get a few groats and masticate them into a pulp. The young bird will readily take this from the mouth. In this manner it can be kept alive till something can feed it. Dozens of the best birds have been saved in this way. The great difficulty with regard to Almonds is the early period at which they leave their young (generally on the fifth or sixth day), and the fancier must be ready the moment they are left to remove them under a pair of feeders which have just hatched. They may be then said, unless any unforeseen accident happens, such as all varieties are liable to, to be out of hand, and require very little more attention. If the old birds have sat on them till the sixth day, let them go to nest again. If they leave them earlier, and have not fed off their soft food sufficiently, supply them with a common young one for a day or so.

Having now considerably exceeded the limit of the space at our disposal, we shall conclude our remarks by hoping they may be found useful to some, and may be the means of still further extending the delightful fancy of which we have been speaking.

HOW LONG ARE QUEENS AND WORKERS IN THEIR CELLS?

AND WHEN DO QUEENS COMMENCE EGG-LAYING?

I AM glad Mr. Woodbury has been induced to set about observing and experimenting, with the view of correcting some of the mistakes which I have made in the natural history of bees. Without admitting that I am wrong on the points noticed in his letter (page 55), I am, as he says, "most anxious to rectify mistakes as soon as sufficient evidence has been adduced to satisfy me that I am really in error." Every honest and truth-loving man is not only anxious to avoid making mistakes, but is ever anxious to acknowledge and rectify those he has made. I hold that there is more honour in confessing a fault or admitting a mistake than there is in conquering a kingdom.

I have read Mr. Woodbury's letter touching my so-called mistakes twice over without finding "sufficient evidence to satisfy me," and until sufficient evidence be adduced I shall be permitted to adhere to my old opinions; and after all, the difference is only a question of forty-eight hours. Very recently Mr. Woodbury admitted that, dating from the removal of an old queen, fourteen days are the average time which elapses before a young one is hatched out, although some are longer. His last experiment, recorded in page 55 of the Journal, indicated that sixteen days elapse before a queen is developed from an egg. This experiment was fairly made and honestly recorded, and I consider that Mr. Woodbury is incapable of acting unfairly in word or deed, and I know something of his diligence in honestly investigating questions of bee-history. No one would rejoice more than myself to see the bee-loving community of this country acknowledge in some tangible and substantial form the services of Mr. Woodbury, better known as "THE DEVONSHIRE BEE-KEEPER."

His queen that was born on the 23rd of June was unquestionably sixteen days in being hatched. I have known queens fifteen and sixteen days in their cells, but I have found that fourteen days are the usual time. Large hens' eggs are sometimes twenty-two, twenty-three, or twenty-four days under the hen, but the usual time is twenty-one days; and so with other animals the period varies. Probably the next experiment made will not tally exactly with that recorded by Mr. Woodbury.

Now as to the production of workers, "THE DEVONSHIRE BEE-KEEPER" says he has "obtained abundant evidence by placing numerous empty combs in 'brood nests' of various hives, and has invariably found that workers commenced hatching not later than the nineteenth day, and in some cases on the eighteenth." The word "commenced" leads me to ask our friend if all the brood of workers was hatched on the nineteenth day in one, and on the eighteenth day in another? for to say it commenced to hatch leaves us to guess when the hatching was completed. I have the evidence of three score of hives artificially swarmed every year to prove that many young bees are unhatched till the twenty-first day after their queens have been removed from them. I swarm about sixty hives yearly, and many of them have all the honey taken from them as soon as the brood is hatched, and I have never found an instance of all the brood being hatched on the twentieth day after the queen was gone, and sometimes I have known workers twenty-two days in being hatched. Besides, the experiment of removing queens from hives altogether is, I think, a far more satisfactory one than that of placing a bit of empty comb in a brood nest. When a queen is removed from a hive altogether I find that her eggs last laid in the hive do not become perfect bees till the twenty-first day after; and if all the bees be removed from the hive on the twentieth day, the unhatched working bees, generally a great number, will struggle out of their cells on the day following. My mode of managing bees for profit leads me to witness this fact almost daily for weeks and months every year. Hence I repeat that twenty-one days are the usual time for workers to be in their cells, "THE DEVONSHIRE BEE-KEEPER'S" late experiment notwithstanding.

The other point of Mr. Woodbury's letter calling for a remark is that touching the fertilisation of queens and egg-laying afterwards. I have said that egg-laying generally commences from six to ten days after impregnation. He mentions an instance of a queen commencing to lay in forty-six hours. I do not question it for one moment, but I may be allowed to state that the fertilisation which he observed was perhaps not the first, and it is not at all unlikely that his queen would have commenced laying drone eggs at the same time if she had never met the drone.

It is exceedingly painful to me to have to offer any remarks apparently in opposition to Mr. Woodbury, and I should be glad to see with him eye-to-eye, but there is a great want of completeness in the evidences he has adduced. I have known many young queens commence to lay ten days sooner than others, and with close observation there will be seen in every apiary a difference of some days as to the time of the successful flight and egg-laying. Every honest writer of experience fairly and faithfully records the evidences and facts that come to him through his own eyes. "The Handy Book of Bees" is welcomed into the homes of rich and poor as an honest production, and the great satisfaction it gives to all classes of readers will be a stimulus to the author to make a second edition, if ever called, for, more complete and satisfactory than the first. Only two or three points in the book have been demurred to by critical reviewers, and our Devonshire friend is satisfied that some other points are wrong, but which cannot readily be put to the test of actual experiment. The author will feel indebted to him if he will kindly catalogue these supposed errors, so that others may examine and test, if possible, the points disputed.—A. PETTIGREW.

[I do not know that I need say much in reply to the above communication, in which, without adducing a tittle of evidence in support of his views, Mr. Pettigrew contents himself with reasserting his errors and cavilling at the facts by which they have been refuted. It seems to me, however, that when a man professes to understand these points in the natural history of the honey bee better than either Huber or Dzierzon, Dr. Evvan or Mr. Laugstroth, something more than this may fairly be required of him. If Mr. Pettigrew has really found that the usual time which elapses between the laying of an egg and its development into a queen is only fourteen days, he can surely have no difficulty in citing at any rate a single instance, stating as I have done the circumstances under which it occurred, and the precautions taken to guard against mistakes. So also with regard to his assertion that egg-laying is delayed until six to ten days after fertilisation; it is scarcely too much to ask him for particulars of one such case, together with the circumstances which attended so remarkable a phenomenon. As in order to weaken my evidence it is suggested that the results which I have recorded may be regarded as exceptional, I would state that I have been breeding queens for the last ten years, during which period scores of instances have come under my direct

observation (sometimes as many as three or four in the same day), and I have never yet known a case in which oviposition did not commence on the second day. Neither, in all my experience, have I ever met with anything that would countenance the belief that a queen can be raised in so short a time as fourteen days from the laying of the egg. Parthenogenesis is a subject which I must decline to enter upon here, but I may remark that Mr. Pettigrew is utterly mistaken in what he fancies to be the effect of my reasoning on this point. I have, however, a high opinion of his abilities as a practical apiarian, and it is for this reason, and because he has expressed himself as being most anxious to correct mistakes, that I have expended no little time and trouble in what turns out to be the vain attempt to set him right. I find it indeed so difficult to satisfy him that he is in error on points which admit of being brought to the conclusive test of actual experiment, that I must excuse myself from particularising others which cannot so readily be submitted to the same decisive proof.—A DEVONSHIRE BEE-KEEPER.]

OUR LETTER BOX.

BRAHMA CHICKENS LEG-WEAR (T. A. D.).—As at thirteen weeks old, and without a drop of rain to cool the surface of the earth, your Brahma chickens have reached 5 lbs. weight, the growth has been so rapid that we do not wonder the legs decline to carry the load of flesh. They are little more than cartilages. What is the leg weakness. Patience and good feeding will remedy that, and as the bird gets older the progress in the right direction will be visible. As his legs gain strength he will carry his body with comfort. We are almost tempted to imagine you have over-fed to attain the weight you mention, and if so, you have induced idle and fat-making habits, which are opposed to the formation of bone and muscle. You would have helped us to have come to a right conclusion if you had given us an idea of the feeding and lodging. The contraction of the toes is not from leg-weakness, but from cramp, and that is either from bad feeding or damp. We do not here speak of atmospheric dampness, but of damp flooring—wood, stone, brick, or asphaltum. Either of these will produce cramp, and when the toes are drawn up and paralysed the appearances are against recovery. If you have any of the floorings above described, take them up, or cover them inches deep in gravel or road grit. Feed the birds on ground oats or meal; give them bread and ale, and also, once a-day, a couple of camphor pills the size of garden peas. These may be discontinued as strength returns. We presume it is only among cocks weakness prevails. If they persist in roosting on the ground, it is well to put a little straw for them in one corner of the house, otherwise they suffer from a round troublesome sore on the hocks.

HOUDAN CHICKENS (Subscriber).—We call your chickens good for their age. In the breeds where weight is one of the principal, if not the principal merit, 1 lb. per month up to four months is called satisfactory progress, and such are viewed hopefully as future prizetakers. See that both are live-clawed, that their legs are spangled, and that the cock has no red feathers. When they grow older and are furnishing, you can always add weight by judicious feeding during the fortnight preceding the show.

DUCKLINGS CRAMPED (E. R. P.).—Where do your Ducks roost? If it is in a house with a stone, brick, or pitched floor, there is the cause. It is cramp. Let them choose their own roosting-place, and recollect in a state of nature they often roost on the water. They do not suffer from any damp that arises from water, but they do from boards, stones, or bricks. You say nothing of food. If they have oats mixed with gravel and a sod of grass in their troughs, with the run of a meadow and a pond, they should do well. Cramp is often induced by insufficient or improper feeding.

SPANISH FOWLS LOSING FEATHERS (E.).—Part of the loss of feather may be attributed to the natural action of the season. The birds are molting; but if they are in confinement and denuded of all save the tail and wing feathers, they are picking each other's plumage and eating it. We know no cure. We believe there is only one, that is to give them their liberty. If at liberty you are convinced by seeing one pick and eat the feather of another, remove the offender; it is a habit, once taken to, that is never given up.

FEEDING RABBITS (A Young Subscriber).—A great point in making good Rabbits is to allow a doe to rear but four young ones. If well fed she will almost fatten them on her milk; but they will not be large. If it is desired to rear as many as possible, and to make them large, they should be fed on oats and bran moderately, with green food, but liberally, and with the greatest variety of roots. They may have milk to drink, and if not milk, they should always have water.

RABBIT MANAGEMENT (A Novice).—Rabbits will not generally indulge in the disagreeable habit named if well supplied with, say, a little milk and bread once a-day, or common peas soaked in water for twelve hours, pouring off the water the peas are soaked in, and giving fresh along with them; or give fresh water alone three or four times a-week, especially during this hot weather, when the juices of all green food are almost dried up from want of rain. It will not be difficult to wean them of the habit complained of by offering them greater and more wholesome attractions in the feeding trough.

REMOVING BEES (D. B.).—We should advise you to dispose of your present stocks rather than incur the risk first of uniting, and then of transporting them from Jersey to the north of England. The canvas hive covers afford shade and excludes rain, but is not a good winter protection.

POINTS OF NUNS (T. A. D.).—Nuns should have from seven to ten light feathers dark, the same colour as the head, also the twelve tail feathers, and a few of the tail-coverts. The body should be perfectly white, as well as the hood, which should be large and well-developed. The eyes should be of a clear pearl colour.

STILL FOR DISTILLING LAVENDER (E. R. P.).—By applying to your

ironmonger he could procure you a small still, suitable for distilling lavender and rose water. Such a thing made of tin is very inexpensive, and answers the purpose equally as well as one much more costly. The following may guide you in making rose water:—Gather the flowers in fine weather two hours after sunrise; take out the calyx, and separate the petals; pound them in a marble mortar to a paste, and leave them five or six hours in the mortar; then put them in a large close cloth, and let two persons wring it with all their strength. Having by this operation obtained 4 lbs. of juice, infuse it in an equal weight of fresh rose petals for twenty-four hours. At the end of that time put the whole into the alembic, which place in a sand bath, and distil it. When you have collected about 1 oz. of the water unite the receiver, and if that which issues from the still is as odoriferous as that which preceded first, continue the operation; but if not, collect it into another vessel, as this second water is not single, and must be kept separate from the first, which is the essential water. Should the second water have an unpleasant smell (caused by the application of too much heat), expose it to the sun for a few days, covered only by a sheet of paper. The utmost care is necessary in distilling this and all other odoriferous substances. A still more powerful essence than the above may be procured by the following method:—Gather as many roses as will afford 30 lbs. of petals, and pound these with 4 lbs. of salt; when pounded place the paste in a vessel in layers, with salt between each; press them closely, cork them tightly, leave the vessel twelve days, and then distil as usual.

METEOROLOGICAL OBSERVATIONS

in the Suburbs of London for the week ending August 9th.

DATE	BAROMETER.		THERMOMETER.				Wind.	Rain.
	Max.	Min.	Air.		Earth.			
			Max.	Min.	1 ft.	2 ft.		
Wed. . . 3	29.822	29.728	72	52	66	62	E.	.00
Thurs. . 4	29.688	29.626	79	51	65	62	S.	.02
Fri. . . 5	29.768	29.670	77	47	68	62	S.	.00
Sat. . . 6	29.874	29.843	81	46	66	62	W.	.00
Sun. . . 7	29.771	29.733	76	57	64	62	S.E.	.12
Mon. . . 8	29.930	29.771	75	51	65	61	S.E.	.08
Tues. . . 9	30.021	29.957	79	53	70	62	N.	.00
Mean. .	29.839	29.762	77.14	51.00	66.28	61.86	..	0.22

- 3.—Overcast; densely overcast; foggy.
- 4.—Densely overcast; fine, cloudy; showery at night.
- 5.—Cloudy but fine; very fine; clear and fine.
- 6.—Fine, cloudy; fine; very fine and clear.
- 7.—Rain; showery; overcast, very damp.
- 8.—Overcast; thunder and rain; heavy clouds.
- 9.—Very fine; cloudy but fine; cloudy, very fine.

COVENT GARDEN MARKET.—AUGUST 10.

A STEADY course of business is maintained, and prices are stationary. There is little alteration either in foreign or home-grown produce, except that the latter now comprises out-door Peaches and Nectarines.

FRUIT.

	s. d.	s. d.	s. d.	s. d.	s. d.
Apples.....	1/6	2/0	2/0	Malberries.....	lb. 0 9 to 0 0
Apricots.....	doz. 1 0	3 0	6 0	Nectarines.....	doz. 6 0 12 0
Cherries.....	lb. 0 6	1 0	0 0	Oranges.....	doz. 7 0 14 0
Chestnuts.....	bushel 0 0	0 0	0 0	Peaches.....	doz. 5 0 15 0
Currants.....	1/2 sieve 2 0	4 0	0 0	Pears, kitchen	doz. 0 0 0 0
Black.....	do. 3 0	5 0	0 0	dessert.....	doz. 2 0 3 0
Figs.....	doz. 3 0	6 0	0 0	Pine Apples.....	lb. 2 6 5 0
Filberts.....	lb. 0 9	1 0	0 0	Plums.....	1/2 sieve 3 0 5 0
Cobs.....	lb. 0 9	1 0	0 0	Quinces.....	doz. 0 0 0 0
Gooseberries	quart 0 4	6 0	0 0	Raspberries.....	lb. 0 6 1 0
Grapes, Hothouse	lb. 2 0	6 0	0 0	Strawberries.....	lb. 0 6 1 0
Lemons.....	1/2 100 8 0	14 0	0 0	Walnuts.....	bushel 10 0 16 0
Melons.....	each 2 0	5 0	0 0	do.....	1/2 100 1 0 2 0

VEGETABLES.

	s. d.	s. d.	s. d.	s. d.	s. d.
Artichokes.....	doz. 3 0	6 0	0 0	Leeks.....	bunch 0 4 to 0 0
Asparagus.....	1/2 100 3 0	8 0	0 0	Lettuce.....	doz. 1 6 3 0
Beans, Kidney	1/2 sieve 4 0	6 0	0 0	Mushrooms.....	potlre 3 0 4 0
Broad.....	bushel 3 0	4 0	0 0	Mustard & Cress	punnet 0 2 0 0
Beet, Red.....	doz. 2 0	3 0	0 0	Onions.....	bushel 4 0 6 0
Broccoli.....	bundle 0 0	0 0	0 0	Pickling.....	quart 0 4 0 8
Brussels Sprouts	1/2 sieve 0 0	0 0	0 0	Parsley.....	doz. 3 0 0 0
Cabbage.....	doz. 1 0	2 0	0 0	Parsnips.....	doz. 0 9 1 0
Capsicums.....	1/2 100 0 0	0 0	0 0	Peas.....	quart 1 0 1 6
Carrots.....	bunch 4 0	8 0	0 0	Potatoes.....	bushel 4 0 6 0
Canflower.....	doz. 2 0	6 0	0 0	Kidney.....	do. 6 0 8 0
Celery.....	bundle 1 6	2 0	0 0	Radishes.....	doz. bunches 1 0 0 0
Coleworts.....	doz. bunches 3 0	6 0	0 0	Rhubarb.....	bundle 0 0 0 0
Cucumbers.....	each 0 6	0 0	0 0	Savoy.....	doz. 0 0 0 8
Endive.....	pickling.....	doz. 2 0	0 0	Sea-kale.....	basket 0 0 0 0
Fennel.....	doz. 2 0	0 0	0 0	Shallots.....	lb. 0 6 0 0
Fennel.....	bunch 0 3	0 0	0 0	Spinach.....	bushel 3 0 0 0
Garlic.....	lb. 0 8	0 0	0 0	Tomatoes.....	doz. 1 0 3 0
Herbs.....	bunch 0 3	0 0	0 0	Turnips.....	bunch 0 6 1 0
Horseradish.....	bundle 3 0	6 0	0 0	Vegetable Marrows	doz. 4 0 0 0

POULTRY MARKET.—AUGUST 10.

	s. d.	s. d.	s. d.	s. d.	s. d.
Large Fowls.....	3 0	to 3 6	0 0	Ginea Fowls.....	0 0 to 0 0
Smaller ditto.....	2 0	to 2 6	0 0	Pigeons.....	0 9 0 10
Chickens.....	1 9	to 2 0	0 0	Rabbits.....	1 4 1 5
Ducks.....	2 0	to 2 6	0 0	Wild ditto.....	0 9 0 10
Geese.....	6 0	to 6 6	0 0	Hares.....	0 0 0 0
Turkeys.....	0 0	to 0 0	0 0	Partridges.....	0 0 0 0

WEEKLY CALENDAR.

Day of Month		Day of Week		AUGUST 18—24, 1870.			Average Temperature near London.			Rain in last 43 years.		Sun Rises.		Sun Sets.		Moon Rises.		Moon Sets.		Moon's Age.		Clock before Sun.		Day of Year.		
				Day.	Night.	Mean.	Days.	m.	h.	m.	h.	m.	h.	m.	h.	m.	h.	Days.	m.	h.	m.	h.	m.	h.		
18	TH	Kirkby Stephen Horticultural Show.		73.2	50.7	62.0	16	51	af 4	15	af 7	23	af 10	after.		21	3	40	230							
19	F	Keighley Horticultural Show.		73.1	49.2	61.2	21	52	4	13	7	46	10	22 af 1		21	3	26	231							
20	S			72.8	50.6	61.7	20	53	4	11	7	17	11	26		2	3	12	232							
21	SUN	10 SUNDAY AFTER TRINITY.		72.6	49.7	61.2	14	55	4	9	7	56	11	29		3	24	3	58	233						
22	M	Length of night 9h. 50m.		71.6	49.7	60.6	17	57	4	7	7	morn.		28	4	25	2	43	234							
23	TU	Wotton-under-Edge Horticultural Show.		71.8	49.0	60.4	21	59	4	5	7	44	0	20		5	26	2	28	235						
24	W	Lewes Horticultural Show.		71.6	47.9	59.7	16	1	5	3	7	43	1	5		6	27	2	13	236						

From observations taken near London during the last forty-three years, the average day temperature of the week is 72.4°, and its night temperature 49.8°. The greatest heat was 92°, on the 18th, 1842; and the lowest cold 36°, on the 18th, 1866. The greatest fall of rain was 0.95 inch.

KENTISH ORCHARDS.



WHATEVER advantages there may be in cultivating our ordinary fruits under glass, and no doubt there are advantages, still it is evident the great bulk of the population must be satisfied with what is grown in the open air in orchards. The word orchard has always appeared to me to have something of poetry and wealth united; the beautiful appearance the orchard presents in April and May is followed, or is

expected to be followed, by a sight not less lovely in August and September, and at either season an orchard forms a very important feature in the landscape. Whether the trees are in blossom or laden with fruit, a full-grown healthy orchard is an object which the most careless never fails to take notice of, added to which the districts where orchards abound are generally well cultivated, and have a clothed appearance even in winter. The utility of orchards in a commercial point of view is also not one of the least of their attractions, and seemingly fabulous prices have often been paid for crops of fruit when sold on the trees. Into this subject, however, I will not enter, but shall content myself with making observations on the system of management which some cultivators adopt with great success.

Considering the great diversity of soil in which the cultivation of Apple, Pear, Plum, Cherry, and bush fruit trees is attempted in this county (Kent), it can hardly be expected that a uniform system of treatment can be recommended, but in general it used to be urged that a Cherry orchard ought to be on grass, and that the ground in which the other fruits were grown might all be in tillage. This idea, with certain modifications, formed the prevailing creed of the last generation of fruit-growers, and is far from being abandoned yet; but of late years many innovations have been made, and the advisability, or the contrary, of tillage has been discussed, some of its advocates pointing to the hedges, the best of which have adjoining the collar, in many cases, about a foot of tilled space free from weeds, and often dug 6 or 8 inches deep; while, on the other hand, the advocates of a turf bottom point to the oldest examples of fruit trees known, and in these think they have a strong plea in their favour, such trees being met in a green hearty old age in a meadow or paddock. The inquiry has led to many experiments, and I have on more than one occasion seen a mode adopted to meet the views of both parties without to any important extent losing the advantages of either system.

Happening lately, in company with a friend, to be travelling a few miles from here, we observed a very promising orchard of full-grown trees, with the usual undergrowth of bush fruits, which appeared to be in the best of health, and bearing abundantly, yet we were told by the proprietor that the ground had never received a particle of dung or other manure for a great many years. This orchard was planted in the usual way in this county, consisting of standard Apple and Plum trees, with 6-feet stems, at 18 or 20 feet apart, underneath them Filberts or

Cob Nuts, with Currants to fill up the intervals, the Cob Nuts being usually 12 feet and the Currant bushes 6 feet apart. The whole presented a mass of bush and foliage which some not acquainted with Kentish orchard-management would say wanted the saw and knife freely, or perhaps the mattock, but these are seldom used to the extent a stranger would think necessary; and whether necessary or not, I will not here stop to inquire. Let the result tell for itself. This mixed orchard, I may remark, was originally in tillage, but Mr. Manwaring, its owner, determined to try if it would not be as well to avoid mutilating the roots by digging, and for many years he has abandoned the use of the spade among his trees, and merely has the weeds hoed up when they are troublesome. In alternate autumns he spreads over the ground some hop-bine cut a little, so as to prevent its entangling anyone passing through it. This covering partly shades the ground, and, decaying gradually, supplies the trees with some additional food to compensate for the drain on the soil caused by what is taken away. It would doubtless be better if this dressing could be given every year, but it cannot always be spared, owing to the other uses the hop-bine is put to, but substitutes are sometimes had recourse to. Any kind of herbage or decaying substance would probably serve the same purpose, and I am not certain whether the result would be much different if nothing of the kind were used, as I imagine the principal benefit arises from the upper roots of the fruit trees not being disturbed by digging; at the same time the surface soil is not exhausted by supporting a crop of grass or hay, as where the orchard is in turf.

The above case is not an isolated one; I may mention one nearer home, where the best possible results appear to follow the adoption of a similar plan. Adjoining the grounds of Preston Hall, near Maidstone, is a fine orchard of some twenty years' growth. This orchard in some degree resembles that last described, being composed of Apple, Plum, and Pear trees as standards, with Filberts, Cob Nuts, and Currants for undergrowth, and as it was planted expressly for the private use of the family, the variety of fruits was greater than is often the case where the produce is intended for market, and I have on several occasions seen most excellent crops of fruit there; yet Mr. Bradley, the intelligent gardener, never puts a spade in the ground, only the weeds are hoed up when necessary, and the orchard forms a receptacle for all the rubbish of the garden, weeds and decaying matter of all kinds being wheeled on and spread about. I remember one year visiting the garden in spring, after a severe winter had made havoc with Laurels and other shrubs, and I found that Mr. Bradley had covered the orchard in a great measure with the foliage, shoots, and slender branches of the evergreens that had been killed or injured in the winter, reserving the stouter woody matter for faggots and other purposes. Decayed stalks of vegetables and other matters were also lying about for the same purpose. I have no doubt that the decomposition of these materials would benefit the soil at the spot where decay was going on; certainly nothing could be more healthy than the trees,

even the Ribston Pippin Apples looked tolerably well, which they rarely do in many places. Mr. Bradley had been trying some experiments with this fruit; he had worked some robust-growing varieties with the Ribston Pippin, and thought the result was more satisfactory than when the latter was not double-worked. I forget which variety was employed, but I think it was the Yorksbire Greening. More than one tree was operated upon with success.

Now, in the two cases referred to, there was a great difference of soil. In the first there was a somewhat adhesive loam, not by any means a stiff clay, but destitute of stones and sharp sand, the subsoil a sort of grey marl, and the surface so fine in texture that water did not easily percolate; in the other case the soil was more open, with a gravelly bottom, dry and porous, but not hungry in the sense in which that term is usually applied, for Plums, in particular, seemed to do remarkably well. The managers of both these fruitful orchards are strenuous opponents of cultivating orchard ground, especially after the trees and bushes have attained some size, and their roots occupy the ground; and certainly the appearance of their orchards indicated the correctness of this view. Their example, indeed, is partially adopted in many cases when the standard trees attain sufficient size to be thought worthy of occupying the whole of the ground; the undergrowth being then removed, grass is sown, but this is a questionable benefit; at least it is doubtful if it is so good as preserving for the use of the fruit crop the whole energies of the ground, whilst providing that shade and covering so necessary to keep in the moisture during such dry periods as we are now passing through.

I might say more on the matter, but I will merely remark that in such a place as an orchard there is ample space for the gradual decay of any woody or vegetable substance that may be put upon it, and the benefit of such substances to the soil they lie upon is evidently not yet sufficiently appreciated, but may be roughly judged by the fact of a stone of some size lying on the ground protecting the roots of all below it, but remove the stone and the result is hurtful. This well-known fact has led in many instances to landlords objecting to their tenants removing stones.

I advise all those who have not tried the plan here described to do so on a small scale, until they feel assured of its success, and in the end I have no doubt they will regard the practice of mutilating the roots of Apple, Pear, and other fruit trees as injurious; at the same time, as some assistance from manure is wanted, and the finer description of dung and easily-worked-in manure may be required elsewhere, the orchard forms a suitable place to deposit all such cartloads of rubbish as are rejected from other quarters. Time works wonders with such unpromising materials.—J. ROUSON.

CULTURE OF THE HERBACEOUS CALCEOLARIA.

With amateur gardeners this beautiful plant is becoming more popular, and with the cottager it is now an especial favourite; most gentlemen's gardeners are in possession of a good system of growing this plant, therefore I only offer my remarks to the first named.

Perhaps the most difficult part for the amateur to overcome is raising the seedlings; in this I think even professional gardeners often err by treating them too kindly. The following is a good plan. Prepare a shallow pan by filling it with light soil; press this down so as to present a very level surface a little below the rim; add sufficient silver sand on the surface to fill up the interstices; water well with a fine-rosed watering-pot, giving enough water to thoroughly moisten the soil, let it drain off, and then sow the seed. After this add a sprinkling of very finely-sifted sandy soil, be careful only to just cover the seeds, and finish by giving a mere sprinkling of water. Place the pan in a hand-light on a bottom of coal ashes; a suitable spot is a cool part of the garden, where no sun but plenty of light can reach the pans. The surface soil must not be allowed to become dry, and water very carefully to avoid washing the seeds out of the soil. The ashes may also be kept moist. A good time to sow the seed is the middle of August.

When the seedlings are large enough to be handled, prick them out an inch apart in pots or pans. If hand-lights can be provided continue the same treatment; but if not, a cold frame will do, placing the plants on a cool bottom, and keeping them near the glass. For a time, at least, they must be shaded from bright sun, but at all times and stages of their growth

they must be well ventilated. Careful and constant watching for snails will be necessary, for if these get in they will take off scores in one night. In about three weeks the plants will be large enough for potting-off; small 60's or small thumb pots may be used, and if the plants have not hitherto occupied a cold frame, let them have the protection of one at this stage and onwards through the winter, if protection from frost and good ventilation can be afforded. The shifting of the plants into larger pots may go on when the plants require it and the weather is favourable; a good general guide, however, is to shift when the roots are well at the sides of the pots, though the plants must not, under any circumstances, be allowed to become pot-bound when in a young state, for it causes premature flowering, and often throws the plants into a sickly state, from which they will not soon recover.

Good specimens may be grown in 6-inch pots, a size, perhaps, large enough for the amateur, but if plenty of space is at command, 8-inch or even larger pots may be used with advantage. Arrange the potting so that the last shift shall not be later than the last week in February.

The compost I recommend to be used consists of strong turfy loam one half, decayed leaf mould and road grit in equal parts to make up the other half; add sand liberally, and about one-fourth of the whole bulk of decomposed cow manure sifted. This soil will do for all the pottings, from first to last, only as the plants increase in size use it in a rougher state.

The plants may be advantageously pinched back about twice in the early part of their growth; this dwarfs them, and considerably increases the number of flower stems. At short intervals give some gentle smokings with tobacco, to keep the green fly in check; remember that if it once establish itself on the plants, the foliage being thick and close to the soil, it is not easy for the smoke to penetrate, and it will be almost impossible to free the plants of the enemy. Water must be given sparingly in the depth of winter, but towards spring, and after the plants have established themselves on their last shift, plentiful supplies may be given, with liquid manure from cow dung added. The great improvements that have been effected in this plant of late years render it no longer a difficult matter to secure a good strain of seed, with a large per-centage of good and distinct-coloured flowers; but the most varied assortment and the most pleasing strain I have grown was from a packet of seed, called Thomson's strain, purchased of Messrs. Veitch.—THOMAS RECORD, *Lillesden*.

GLOXINIA CULTURE.

POSSESSED of rare elegance of form both in its foliage and flowers, easy to cultivate and to maintain in full beauty and freshness for a considerable time, the Gloxinia takes high rank amongst summer-flowering pot plants. Strictly speaking, it is a tuberous-rooted stove plant, and this is doubtless the reason why Gloxinias are not more frequently to be seen in the amateur's collection of plants contained in his solitary greenhouse or conservatory. Many persons who admire them very much never think of attempting to grow some, because they have no stove or other glass structure in which a high temperature is maintained. Now this is a mistake; and it is my object in writing this paper, while treating of Gloxinia culture generally, also to endeavour to show how the plants may be grown and kept from year to year by persons having only one glass house, without the aid of a very high temperature.

A cheap and easy method of obtaining a collection of Gloxinias is to purchase a packet of seed, which should be sown early in March on the surface of a pan well drained and filled with fine soil. The seed should not be covered, but the pan should be placed in the brisk moist temperature of a hotbed, and the soil kept damp. When the young seedlings have formed two leaves they are potted singly in 3-inch pots and kept in the same position, taking care to paint the glass with whitewash, as all Gloxinias, and especially young plants, thrive best when kept moderately shaded. The seedling plants form firm tubers in the 3-inch pots, in which they are kept throughout the first summer and winter; as growth ceases they may be removed to a cool house, and they are stored in winter on any spare shelf where the temperature is kept at about 10° above the freezing-point. The tubers are not disturbed till spring. The only important point in their winter management is to see that the soil never becomes very dry, for if it is not kept somewhat moist every tuber will perish of dry rot.

When spring comes round again, or rather at any time in the first four months of the year, the plants may be shaken

out of the old soil, repotted in the same pots, and placed in a temperature similar to that in which they were raised from seed. As they make growth they should receive one or two shifts into larger pots, and be brought into flower in a house kept at a temperature of 65° or 70°. All these kinds, the flowers of which show that the plants are worth keeping, may now be considered to be established plants. As the flowers decay the plants should still be constantly watered, so as to make the decay of the foliage a very gradual process. By the time they are stored away in their winter quarters young growth will be just visible on the crown of each, and this is precisely the state in which I like to have them throughout the winter, during which they occupy a shelf at the back of a cool house from which frost is excluded. Care is taken not to saturate the soil in winter, but it is always kept in such a moist state that the few small leaves remain fresh and green; and as each successive batch is potted in fresh soil in spring, strong vigorous growth quickly follows.

Gloxinias are also increased by cuttings of the shoots and leaves. Shoots taken off the plants early in spring will form plants and produce a few flowers the same season. The best way to propagate by leaves is to insert each leaf upright and firmly in rich sandy soil in a 3-inch pot; placed in a vinery under the shade of the Vines and kept well watered, they produce fine tubers, which make good succession plants for the following season.

It has frequently been stated that the influence of a high temperature is necessary to enable Gloxinias to start into growth strongly and well, and so their culture would appear of necessity to be confined to those persons having such means at their disposal. A fair trial of the cooler method of culture, which I will now explain, will show this advice to be somewhat fallacious. If the owner of one of those pretty little conservatories now so frequently to be seen attached to villa residences be desirous of growing a few plants of this charming family, some strong young plants just coming into flower should be obtained, and kept while in bloom under the shade of some of the creepers which will probably be trained to the conservatory roof. As they go out of bloom they should be treated in precisely the way I have described, storing them closely on any back shelf where they can have light and are safe from drip and frost. So they should pass through winter, and as spring advances, and the young growth exhibits signs of animation, they are taken down, shaken carefully out of the old soil, and repotted in the same pots in soil composed of two parts loam and one part each of old decayed dung, sand, and broken charcoal. A position on the stage near the front of the house, where they can enjoy the morning sun, but are shaded at mid-day, will suit them admirably. Avoid exposing them to draughts, and syringe the foliage with clear soft water twice a-day, taking care to water the roots thoroughly when necessary. So treated they will grow steadily; and when the roots touch the sides of the pots, if large plants are required, they should receive a liberal shift, but otherwise a little guano water given occasionally will much assist the development of the foliage and flowers, which will be in full beauty early in August, and will continue so to nearly the end of September.

Gloxinias may be grown after this simple fashion to the greatest perfection, the plants being quite equal in vigour and beauty to those grown in a stove. Moreover, by this method a splendid lot of succession plants may be had, which will serve to prolong the flowering season, and thus prove in the highest degree serviceable to the gardener.—EDWARD LUCKHURST, *Egerton House Gardens, Kent.*

POMOLOGICAL GLEANINGS.

THE following NEW STRAWBERRIES are this year introduced by M. Gloede, of Beauvais:—

Baron Brisse (Gloede).—Large and rich, of quite a novel yellowish colour, rather late, and very productive.

Belle de Nantes (Boisselot).—Extremely large, and handsome shape, flavour first-rate; a noble dessert fruit. Plant exceedingly robust, and coming in very late.

Constantin Tretiakoff (Gloede).—Large and very handsome; colour deep brilliant scarlet, flesh solid and rich. A strong grower, very prolific, and remains long in bearing.

Favourite (Madame Clements).—Large, even conical shape, bright orange, of exquisite flavour. An improvement on Carolina superba, and a good forcer.

Helena Gloede (Gloede).—Very large and of delicious flavour. A noble fruit, ripening very late; will be valuable as a highly

improved Frogmore Late Pine, which it resembles as regards size and flavour, but to which it is far superior in growth, hardiness, and lateness.

President Delacour (Horticultural Society's Trial Gardens at Beauvais).—Large, globular shape, bright glossy red. A very showy Strawberry, solid, rich, and bntery. Plant very hardy and extremely prolific. Ripens at the medium season.

Roseberry maxima.—This is a very fine, large, and useful Strawberry, extensively grown in Russia, especially for early forcing. Exceedingly hardy and prolific; belongs to the Pine class. Real origin unknown.

Alpine Trouillet.—A much-improved variety of the Red Alpine Strawberry; fruit of large size for its race, and an immense bearer till frost sets in.

SELECT GARDEN ROSES.

NOT a few of the numerous Rose amateurs who regularly read "our Journal," and whose first eager glance over the headings of the various articles is to single out for immediate perusal any that relate to their especial favourite, must have experienced astonishment while scanning over a list of Roses, set forth as a select one, which appeared in page 98 of last week's issue. In the section of Hybrid Perpetuals (Remontants), there are sixty-one varieties named. Of these, Prince de Portia, Jules Margottin, John Hopper, Beauty of Waltham, Paul Verdier, Marguerite de St. Amand, Charles Lefebvre, Alfred Colomb, La Ville de St. Denis, Caroline de Sansal, Pierre Notting, Marie Raby, Antoine Ducher, and Prince Camille de Rohan are really first-class Roses, and should be in every collection, large or small, but their number all told amounts to only fourteen, or less than one-fourth of the whole selection; and one, Paul Verdier, is a very doubtful remontant, while Miss Ingram, also in the list, is certainly not remontant.

Of some merit, but by no means to be considered so good as the preceding, are Madame Clémence Joigneaux, occasionally fine, but too often coarse and dull in colour, not full, nor sufficiently remontant; Jean Goujon, large, but rough; Monsieur de Montigny, good, but of weak constitution, an insuperable bar to recommendation; Madame Charles Wood and Madame Moreau, remarkable for size, which renders them popular among exhibitors, but deficient in several respects. Léopold Hausburg has ceased to find favour from the inconstancy of its bloom; it occasionally produces a good flower; it is also surpassed by others of similar colour. Madame Alfred de Rougemont is praised by some rosarians on account of its pure colour; it is now superseded by Boule de Niede, which "inquirers" should substitute when they make their purchases. Madame Vidot is acknowledged to be a beautiful Rose, but few, if any, can grow it satisfactorily. Madame Knorr may still receive partial favour for its unique colour and free-blooming qualities. Madame Rivers, too, would be one of the most beautiful, and therefore one of the most valuable, of light Roses if it were but strong enough, but with regret we must place it among the things that were. Thus ten more in the list may receive a qualified recommendation, and this in some cases rather faint.

The remaining three dozen, or thereabouts, I would utterly discard from the rosery, if there already, and, of course, rigorously exclude their entrance for reasons which shall be stated. Taking them *seriatim*, or in groups, it seems almost a waste of time and space to discuss them; but people might be misled unless the fallacy of such a list offered for their assistance be fully exposed:—Mlle. Alice Leroy and Duchess of Sutherland are Roses of the past, which nobody would speak or even dream of now that we have the superb Baronne de Rothschild, a truly magnificent addition to our light kinds. Comtesse de Turenne, who has proved this? at what great show has it carried off honours? Duchess of Norfolk was once thought a good Rose, but who would care for it now in comparison with Madame Victor Verdier, Horace Vernet, Marie Baumann, Léopold Premier, Maurice Bernardin, Camille Bernardin, Maüchal Vaillant, and Sénateur Vaisse, every one of which should be chosen a long way in preference to the trash we are now reluctantly compelled to discuss? They are also among the best known and most familiar of all Roses. Of Baronne Prévost, still in almost every garden, an eminent rosarian, who contrioutes much valuable information to these pages, on one occasion wrote to me, "Poor Baronne Prévost, her glory is departed," which is so too true. Sir Rowland Hill. Does it exist? has it ever existed? or is it what mathematicians call "an imaginary quantity?" or, is it one that

should be rescued from oblivion, as a souvenir of the great postal reformer? Rev. H. Dombrain, let us hope to retain the person but not the Rose for many many years to come. Géant des Batailles, Pauline Lantzeur, François Premier are of a tribe long since deservedly gone out of favour; flat, and with small notched petals when expanded, of varying and often dull colour, with little or no substance—there is no longer room nor necessity for them; Jean Rosenkranz, not half so good as its manifest parent, Jacqueminot, the "old Général" destined to brave many a rude buffet yet; Madame Boll, rough and coarse; La Reine, an old Rose hard to expand, producing an overwhelming per-centage of bad to good flowers, its place fully applied by Comte de Nanteuil, still a superb variety, Gloire de Vitry, and La Ville de St. Denis mentioned above; Triomphe de Caen and Merveille d'Anjou, neither a triumph nor a marvel at all. Duchesse d'Orléans must still have friendly remembrance, it is now completely eclipsed by the lovely Marquise de Mortemart. William Jesse recedes far into the earliest recollections of the oldest rosarians; to Rose annals it is almost prehistoric. Souvenir du Comte Cavour is still in favour with me on account of its colour, symmetrical form, breadth of petal, and robust habit. I yield to the judgment of many experienced growers and pass it by; it is surpassed in some respects by Xavier Olibo and Duke of Wellington, and infinitely so by Lord Macaulay, one of the most brilliant and attractive of all the crimson-scarlet Roses of this shade of colour. Monsieur Boncenne must also claim notice, although its remontant qualities are very defective, if not entirely absent. Alba carnea, Madame Pulliat, François Treyve, and Comte Litta have been weighed in the balances and found wanting. Joseph Fiala is praised by Mr. Keynes, but, I believe, he almost stands alone in his estimation of it. Madame Fillion does not yield flowers enough to pay for cultivation; it is very beautiful when it does come. Pius IX. fails. Charles Rouillard, Auguste Mie, and Reine du Midi, are a multiplication of varieties worthless compared with Chabillant, Thérèse Levet, La France, Dereux Douvillé, a neglected but fine Rose; and the robust William Griffiths. Anna de Diesbach was fashionable about the time that crinoline was à la mode, of which it may be said to be a synonyme. A floral critic, I forget who, once enunciated a very famous apothegm in these pages; it was, that "the graces of ladies should be imitated, not their garments." Crinoline is gone, Anna de Diesbach will soon disappear too. Le Géant and Jean Lambert are loose jaunty flowers soon to be forgotten. Thorin is still in debateable ground; with me in light soil it does no good. Felix Genero is still worse.

There are yet more in the list under notice that I have not reproduced. I cannot but think that so palpable an error in judgment as is shown in the article at pages 97 and 98 will be fully challenged and refuted by the able contributors to the Journal on Rose subjects, and that my own omissions will be amply made good by them. A few more remarks remain to be made. Following the section containing the list of Hybrid Perpetuals are six paragraphs assigned to as many different classes. Five varieties of Hybrid Chinas and Bourbons are recommended to the "many inquirers" to select, including Vivid and Paul Ricaut, both surpassed by many remontants of the same colour. Blairii and Charles Lawson are omitted, although superior to any of the five inserted. Few will now care to grow the Alba Roses, Félicité and Queen of Denmark, in preference to Acidalie, Souvenir de la Malmaison, Boule de Nègre, or even Baronne de Maynard, none of which receives a notice; and among Moss Roses the old Crimson will always be the most admired. Two Tea Roses only are mentioned—Gloire de Dijon, which everyone must have, and Homère, a peculiar but certainly not a good Rose. The pretty Céline Forestier, which can be grown almost everywhere, is left out. Marchel Niel, almost as hardy as Gloire de Dijon, is ignored; Sombrenil, a beautiful hardy white Tea Rose, finds no place; the useful free-blooming Narcisse, so easy to grow and propagate, is passed over. In fact, throughout the whole list the omissions are as extraordinary as the insertions.

Enfin, but no; let one glance be given to the descriptions, or, I should say, the colours of the different kinds named. "Brevity is the soul of wit," hence nearly all are described in single words. To select a few. Jules Margottin and Beauty of Waltham are "cherry." What did Mr. Radclyffe think of his "old jewels" being thus characterised? Alfred Colomb and Clémence Joigneux "red;" they are as much alike as the sun and moon, but then "red" is a comprehensive quality. Pierre Notting is "dark red." Paul Verdier, Madame C. Wood, Souvenir du Comte Cavour, and Prince Camille de Rohan are

all "crimson;" it would not be correct to say that they are not—it is equally untrue to say that they are and nothing else.—ADOLPHUS H. KENT.

PLANTS FLOWERING IN JULY.

- | | |
|---|--|
| July 4. <i>Linum</i> Lewisii
grandiflorum
narbonense
alpinum
perenne
flavum
Frankenia lœvia
Cineraria maritima
Lathyrus grandiflorus
splendens
latifolius
Rosmarinus officinalis
Lilium tigrinum
aurantiacum
candidum
chalcedonicum
longiflorum
Thunbergianum
Amorpha fruticosa
fragrans
Spiraea daurica
pranifolia
lanceolata
Lonicera longiflora
sempervirens
Xylosteum
Rudbeckia laciniata
Newmanni | July 19. <i>Liatris</i> spicata
pycnostachya
elegans
Lycium Salicaria
Lavandula Spica
Philadelphus grandiflorus
Aster alpinus
levis
Tripolium
Catalpa syringefolia
Astilbe rivularis
Statice latifolia
incana
Scabiosa lutea
nana
Clematis cœrulea
Flammula
florida
Primula acutis
cortusoides |
| 8. <i>Antirrhinum</i> majus, varieties
Statice bellidifolia
Gmelini
Nymphaea alba
Aclaya spicata
Catananche bicolor
Sedum acre
dasyphyllum
Forsterianum
kamtschaticum
Azalea glauca
nitida
viresca alba
Caronilla varia
Tilia europæa
Anbrietia Mooreana
græca
Campbellii
Silene Schaftii | 23. <i>Ariatolochia</i> Siphoe
Ceanothus americanus
azureus
Magnolia tripetala
Dianthus deltoideus
cesius
Erica tetralix
Hypericum calycinum
Leycesteria formosa
Kalmia latifolia
glauca
Rhus Cotinus
Sedum populifolium
acxangulare
dentatum
Telephium
Phlomis Russelliana
Mirabilis Jalapa
Iberis Tenoreana
Gladiolus breuchleyensis
Mimulus cupreus
tigrinus
maculosus
cardinalis
Centaurea candidissima
gymnocarpa
Mitraria coccinea
Phlox Nelsonii
sastacea |
| 11. <i>Aconitum</i> Napellus
Solidago virgata
cambrica
Helianthus diffusus
multiflorus
Symphoricarpos racemosa
Hesperis matronalis
Spiraea japonica
venusta
Aira cœspitosa
Eucalyptus latifolia
Liriodendron tulipifera
Sempervivum tectorum
Rhododendron hirsutum
Hedysarum coronarium
Buddleia globosa
Hemerocallis fulva
Escallonia rubra
Stachys lanata
Viburnum Tinus
Potentilla alba
insignis
Hopwoodiana
Aquilegia glandulosa
Ajuga reptans
Nierembergia rivularis
Hottonia palustris
Nuphar lutea
Potentilla fruticosa
Pyrethrum Parthenium
Salvia fulgens
bicolor | 25. <i>Geum</i> coccineum
rivale
montanum
Pentstemon gentianoides
glabrum
procerrum
ovatum
Sconleri
venustum
Morina persica
Linaria alpina
Polygoum Brunoni
Sieboldii
Polemonium cœruleum
Richardsonii
Dianthus odoratus
superbus
petraeus
Chelone barbata coccinea
Malope grandiflora
Malva zebryna
Morani
Teucrium fiata
Phlox Drummondii
Nemophila insignis |
| 14. <i>Hedysarum</i> coronarium
Buddleia globosa
Hemerocallis fulva
Escallonia rubra
Stachys lanata
Viburnum Tinus
Potentilla alba
insignis
Hopwoodiana
Aquilegia glandulosa
Ajuga reptans
Nierembergia rivularis
Hottonia palustris
Nuphar lutea
Potentilla fruticosa
Pyrethrum Parthenium
Salvia fulgens
bicolor
Lychnis coccinea
Hæcæana
chalcidonica
Viscaria plena
Clematis erecta
integrifolia
Campanula Hostii
garganica
grandis
pyramidalis
rotundifolia
Trachelium | 30. <i>Mesembryanthemum</i> glabrum
tricolor
Lobelia ramosa
Targetes patula
pumila
Aster chinensis
superbas
Adonis autumnalis
Lavatera trimestris
Portulaca aurea
insignis
Silene compacta
rubella
pendula
Viscaria splendens
Convulvulus major
Verbena venosa
Clintonia pulchella
Yucca glaucescens
angustifolia
gloriosa
filamentosa
Veronica candida
incans
Cacalia aërea
Jasminum fraticans
Cobea scandens
Abronia umbellata |
| 16. <i>Myosotis</i> alpestris
Lysimachia ciliata
Nymularia
Colechium autumnale
Oxalis Bowiana
floribunda
Mecoptopsis cambrica
Erica raurentacea
Koniga maritima variegata
Inopsidium aculea
Eriothera acanthis
fruticosa
macrocarpa | |

—M. H., *Acklam Hall, Middlesbrough-on-Tees.*

LAWN MOWERS.

THE trial of lawn mowers is very important, and all lovers of a velvety and verdant lawn are deeply interested. I have

used only Green's 16-inch machine for some years; it is very hard work for two men. If the grass is long it cannot catch it, and fine short grass it almost tears up by the roots. During the past three years my grass plots have been much burnt up and very ugly; this made me desire a better machine. When the Archimedean was announced I wrote to inquire, and had one offered no cure no pay, and on trial I was glad to keep it and pay for it. My gardener, having been ill, is now only weak, so I volunteered to mow the grass, of which I have more than half-an-acre. I have mown it all myself during the past three weeks, with the exception of a small portion, which was cut last week with Green's machine by two men, but the result is very inferior. The grass left on by the Archimedean is a benefit; the turf improves and becomes like velvet. I can work the machine easily; it is a delightful implement, its work a success, and those who wish to know more may come and see or write. —THOMAS BAINES, *Stock House, Bingley.*

STRAWBERRIES WORTHY AND UNWORTHY OF CULTIVATION.

YEAR by year our Strawberry lists are extended, new and wonderful varieties coming upon us from every quarter; to grow even a dish of each would fill with plants an ordinary-sized garden. Variety is getting so abundant as to be perfectly embarrassing, and amidst so much variety there must necessarily exist much inferiority. If our Strawberries have been improved—and they have been so considerably—many sorts are thus superseded, and ought to be discarded and forgotten. To grow inferior sorts is certainly useless; to have to purchase such is more than vexing. Feeling that "to know what to avoid" is good knowledge, we subjoin a list of varieties which have come under our personal observation, both during the present and the last year, and which ought to be entirely discarded. Some of them may, perhaps, in certain localities, and for certain purposes, prove passable. We venture to say, however, they are but few, and that even these are improved upon and superseded. We have this season examined upwards of four hundred named kinds, and out of these we discard the following:—

A. Van Geert	Gélineau	Nimrod
Adair	Globe	Nonsuch
Admiral Dundas	Goländer	Old Chili
Ambrosia	Great Eastern	Orange Chili
Augusta Kitmeyer	Great Exhibition	Orb
Australia	Green's Prolific	Palmyre
Baronne DamsLanage	Hscquin	Patrick's Seedling
Beauty of England	Helena Jamsin	Peabody's Seedling
Beehive	Hendries, Seedling	Pearl
Belle Artoisienne	Henrietta	Pitmaston Black
Belle Cauchoise	Héro	Prince Charlie
Belle de Paris	Highland Mary	Prince Arthur
Bicolor	Hooper's Seedling	Princess Alice Mand
Blandford	Hovey's Seedling	Princess Fredk. William
Bostock	Iowa	Princess of Wales
Boston Pine	Jenoy Lind	Princess Royal of Eng-
Bonbon	John Powell	land
Bonté de St. Julien	Jucunda	Progrès
Boule d'Or	Jung Bahadoor	Richard II.
Brighton Pine	Kimberley	Robert Traill
British Queen Seedling	King Arthur	Roseberry
Britannia	Krsminsky	Rosebud
Brittany Pine	La Boule du Monde	Royal Victoria
Ceres	La Fertile	Ruby
Chinese	La Grosse Sacrée	Rusitoniensis
Choix d'un Amateur	La Negresse	St. Lambert
Cole's Prolific	La Paysanne	Sanspareil
Comte de Zans	La Perle	Savoireuse
Comtesse Theresa Kickx	La Petite Marie	Scott's Seedling
Comtesse de Marne	La Reine	Sir Walter Scott
Cornish Diamond	La Rustique	Stirling Castle Pine
Cornucopia	La Vineuse	Sultane
Cox's Hybrid	Ladies' Finger	Surpass Grosse Sacrée
Déjàne	Le Baron	Surprise (Myatt's)
Délices du Palais	Le Titans	The Lady
Délices d'Antoine	Lecoq Pine	Thomp's Seedling
Dr. Karl Koch	Léon de St. Lannier	Topsy
Deptford Pine	Leopold	Trolopp's Victoria
Douglas's Californian	Lorenz Booth	Triomphe
Duchesse de Besamont	Lord Clyde	Triomphe de Gand
Eliza Champion	Mon Gout	Unique Scarlet
Elton Pine Improved	Monstrouse de Robins	Versailleuse
Excellentes	Munro's Scarlet	Virgin Queen
Fairy Queen	Muscadine	Virginie
Fertile d'Angers	Myatt's Mammoth	Wellington
Filmora	Myatt's Prolific	Wilmet's Superb
Garibaldi (Nicholson)	Né Plus Ultra	Wizard of the North
General Havelock	Newton Kyme	Wonderful

the number is really not required, yet we here enumerate them as possessing some distinctive property. Those the most meritorious in our estimation we have marked with an asterisk *.

- *Ajax, very large, fine colour, splendid for forcing.
- Alice Nicholson, fine quality.
- Ascot Pine Apple, fine quality, early.
- Bicton Pine, best white.
- Black Prince, useful early sort.
- *British Queen, finest quality, suitable for some soils.
- Comte de Paris, splendid colour and texture.
- Crimson Cluster, Hautbois flavour.
- *Dr. Hogg, finest quality, large, fine constitution.
- *Duc de Malakoff, the largest of all.
- Duke of Edinburgh, large and very handsome.
- Duke of Edinburgh (Moffat's), very large, fine market sort.
- *Elton Pine, best late-preserving.
- Empress Eugenie, great bearer, large size.
- *Frogmore Late Pine, excellent late variety.
- *Gloria, excellent early sort, fine flavour.
- Grove End Scarlet, good preserving.
- Har Majesty, large and handsome.
- Highland Chief, excellent quality.
- *Keens' Seedling, one of the best for forcing.
- Kitley's Goliath, great bearer in some soils.
- *La Constants, finest quality, remarkable habit.
- *Lucas, very large, fine constitution and quality.
- May Queen, the earliest of all, but very small.
- *Mr. Radclyffe, large and excellent.
- Myatt's Eleanor, fine appearance, late.
- *Myatt's Eliza, finest quality.
- Old Scarlet, good preserving.
- *Oscar, fine quality, splendid colour.
- *Old Pine, fine quality, distinct character, bears well in the shade.
- Perpetual Pine, interesting as a variety.
- *Premier, fine quality, great bearer.
- President Wilder, large, handsome.
- Prince of Wales (Cuthill's), extraordinary bearer, late.
- Rifleman, great bearer, large.
- Royalty, fine quality, great bearer.
- Scarlet Cluster, fine colour, good quality.
- *Sir C. Napier, most profitable for the London market, excellent for forcing and general purposes.
- *Sir Harry, large, splendid cropper, fine market sort.
- Sir J. Paxton, excellent variety.
- Souvenir de Kieff, very handsome, large.
- *The Amateur, very large, enormous bearer.
- W. J. Nicholson, fine quality, large.
- Waltham Seedling, enormous bearer, good.
- *Vicomtesse Héricart de Thury, the most generally useful.

Synonymes are not here given. There are, in addition to both of these lists now given, a great number of varieties which may be termed of mediocre quality, but sufficiently good for retention in large collections, or for some particular use, or for being specially suited for some particular soil or district; also a never-ending stream of novelties, or so-called improvements, or repetitions of the same under other names; likewise many others which have never come under our observation, as we write only of our own knowledge and experience.

DOUBLE GERANIUMS.

I CANNOT agree with "D., Deal," that the double Geranium is good for bedding purposes, for as Mr. Abbey justly says in his article last week, the centre of the trusses is very apt to clog and mildew in wet, and turn black in dry weather. I have tried several varieties, and found all fail, even the double Tom Thumb; this Mr. Abbey thinks might do. But there is one purpose I find them very suitable for, and that is window plants, as they remain a very long time in bloom, and the centres of the trusses, being perfectly dry, scarcely change colour, while they have the advantage of retaining their petals until removed altogether, and having this property they are also very suitable for button-hole flowers.

I have grown the following in my window this year—Gloire de Nancy, Smith's Victor, Victor Lemoine, Marie Lemoine, Madame Lemoine, Vésuve, and Wilhelm Pfitzer. Of these I think Marie Lemoine the best light colour, being so compact in its growth, but Madame Lemoine is also good. Gloire de Nancy ought to be kept dry to prevent its growing too strong, and it will then open well. Victor Lemoine is by far the best and brightest of the scarlets, a very good trusser, and of dwarf habit. Vésuve is of the same colour and shape as Smith's Victor, but not so dwarf in habit, but both heavy in colour and small in truss. Wilhelm Pfitzer is also a dull red, ragged in form

We next furnish a shorter, yet sufficiently extensive, list of those varieties which have proved sufficiently meritorious for some purpose or other to warrant their retention. One-tenth

of flower, and rather a strong grower. So I retain but two as first-class, Victor and Marie Lemoine, and Madame Lemoine and Gloire de Nancy where more height is wanted. Growing these varieties in a window they are apt to draw a little, which prevents the flowers being too closely packed, so they open much better, and have a finer effect, and being in a cool atmosphere last in bloom a very long time.—HARRISON WEIR, Weirleigh, Kent.

HORTICULTURAL CONGRESS AT OXFORD.

(Continued from page 104.)

THE following paper by Mr. Thomas Moore, F.L.S., was read on the second day of the Congress, and is of much interest to those who have to act as judges, as well as to exhibitors.

ON JUDGING PLANTS AND FLOWERS.

THE object of this paper is to bring out as briefly as possible, and rather in a suggestive than an exhaustive manner, a few practical thoughts in reference to the more important of the laws which should regulate the judging of plants and flowers at horticultural exhibitions. The subject is one of the greatest importance, and it is also so extensive that I can do little more than touch upon some of the more salient points. To do this effectually, it will be necessary to treat separately of:—I. Plants staged in collections; II. Plants staged as individual specimens; III. Plants and flowers staged as novelties; IV. Flowers staged in the cut state.

§ I.—As examples of the subjects which fall under the head of Plants staged in Collections, the groups of Pelargoniums, Heaths, Roses, Orchids, miscellaneous stove and greenhouse plants, &c., may be cited. In judging groups of this character, the following points should be carefully estimated, and their true value credited to the several collections, in the following order:—

1. *Conformity with the Terms of the Schedule* under which they are shown. This, it must be evident, is the first and most important point to be decided, since, if the group, as a whole, or in respect of any of its component parts, does not meet the terms under which it has been invited, it is at once removed beyond the pale of competition, and must be set aside or disqualified. On this account it is of the utmost importance that prize schedules should be explicitly and clearly worded. Moreover, in making up a schedule, undefined groups should be avoided. They are fair neither to exhibitors nor judges; the former are uncertain what to stage, the latter cannot possibly compare and adjust the points of merit between objects which are not comparable.

2. *Health and Vigour*.—Plants which are in an evidently sickly or moribund condition are not likely to be often exhibited, but when they are, they are to be regarded as blots and blemishes. What are more likely to be seen at exhibitions are old, worn-out, debilitated specimens—plants which have served a good purpose in their day, and which still have, it may be, the recommendations of size, and of producing abundance of blossoms, but beneath which the experienced eye can detect the signs of decrepitude. Such plants as these should not be preferred before younger and more vigorous specimens merely because they happen to be larger, if the younger plants are fairly over what would be known as half specimen size, and are otherwise good examples of cultivation as to growth and bloom. In other words, young vigorous growth, with its robust, high-coloured flowers, is to be preferred to stunted growth and starved flowers, even though the plants may be considerably smaller. This is equally true in respect to plants grown for their foliage; vigorous youth must here also come before stunted old age.

3. *Freshness and Unimpaired Condition*.—The foliage of exhibition plants should not only be well-developed, but fresh and in an uninjured state; the flowers should be perfect, and without blemish. Such plants come decidedly before others that from any cause may have become bruised, broken, or disfigured, as regards either stem, leaves, or flowers. Injuries of this sort chiefly occur in packing and transit, but all such defects must count as decided blemishes.

4. *Intrinsic Beauty*.—This may be of two kinds, floral beauty or leaf beauty, and both may sometimes count in the same group. Thus in a collection of miscellaneous flowering plants, while flowers are essential, and the floral display may carry high marks, yet where elegant or ornamental foliage is associated with these handsome flowers, still higher marks must be allowed. In florists' subjects, Pelargoniums or Fuchsias for example, on the other hand, the floral beauty of the subjects has mainly to be considered, the foliage being similar in all, while any differences it may present will have been estimated under the heads of health and freshness. Singularity of form may sometimes compensate for want of colour beauty. There may also be subjects whose beauties, such as they are, are of a plain or ordinary character, and which are not therefore effective; and such plants count rather as blemishes than otherwise.

5. *General Compatibility*.—In all collections there should be an evident fitness of plant to plant, a general resemblance, though not necessarily a rigid uniformity of character, especially as to size, quality, and style. Sometimes in marshalling his forces an exhibitor will bring into his collection some one or two magnificent specimens as a makeweight against sundry inferior ones, and with inexperienced

judges the artifice now and then succeeds, since they cannot free themselves from the impulse to reward the superior plant or plants. This, however, should always be discountenanced, and a certain average amount of merit throughout the group, higher or lower according to circumstances, insisted on. The whole of the plants in the group, whether many or few, should fit into their respective places as though they had been prepared for them. There may be some larger to occupy the back or centre of a group, and some smaller to take the front places; but there should never be one or two very large plants mixed up with several very small ones, nor one or two small plants associated with several large ones. If there cannot be an approximate equality of size, there should be a gradation, and that not too sudden. As to the form of individual plants, that must vary to some extent with the subjects, especially in miscellaneous groups, but the contrast even here should not be too violent; and in the case of collections of particular flowers, as Pelargoniums, Roses, &c., there should be an approximation to symmetry and uniformity of outline, as well as of size.

6. *Size* should only count where other conditions are equal. In urging this point, it is not intended to depreciate fine, large, and really healthy specimens, since these, of whatever kind, are the pride and glory of our plant shows, but only to insist that mere size is never to be preferred to perfect health and irrefragable condition and finish. The old proverb comes in very true here—the biggest not always the best. Size is of course comparable only between different classes, some subjects naturally attaining larger dimensions than others.

7. *Rarity* is an element which must be allowed to have weight after the few first and most essential points. There must be some variety, and the greater the variety after the essential points are met the better; but beyond the avoidance of positive sameness too much importance must not be attached to the mere circumstance of a group being highly varied. This is one of the points upon which schedules should be made especially clear, so that it may be thoroughly understood if distinct species or varieties are required, and whether or not duplicates are admissible.

8. *Facility of Culture*.—The least weight should be attached to the plants which are most easily cultivated, other points being equal, though, as a considerable amount of skill is necessary to bring any plant into a state fit for exhibition, too much importance should not be attached to plants of difficult culture. An easily grown plant, thoroughly well done, perfect in every point, may even be better than a moderately good plant of a more difficult subject, and is certainly better than an inferior one of that class.

9. *Rarity and Intrinsic Value* take about the same position as facility of culture and variety. All these may be, and should be, taken into account, but they are scarcely essential, and certainly not of primary importance. Rarity is the least important of them all, since it may add nothing to the beauty of the show; and the money value of the objects is not the ground upon which the plants are brought into competition. As auxiliary points in collections that come near together in merit, these may be fairly considered; but certainly too much importance should not be attached to them. Horticultural exhibitions are held for the display and reward of cultural skill, not for the appraisement of the objects shown. The latter is a consideration more suited to an auction-room than a flower show.

§ II. The considerations which give importance to the several points of merit in the case of plants staged as Individual Specimens, and which may include such subjects as Azaleas, Heaths, Pelargoniums, Orchids, Palms, Ferns, or any of the plants included in miscellaneous collections, are almost, if not exactly, the same as those already advanced, and therefore need not be repeated. They should be taken in the order indicated, and perfection in each should in these cases be insisted on.

1. *Conformity with the Terms of the Schedule*.

2. *Health and Vigour* as opposed to weakness and infirmity.

3. *Freshness and Unimpaired Condition* as opposed to decay and mutilation.

4. *Intrinsic Beauty*, which must here include, so far as they properly attach to the particular kind of plant under examination, such points as free and symmetrical habit, profusion of well-displayed flowers, pure or pleasing colours, firm and enduring flowers, and succession of bloom,—points which will be more specially noticed under § III. New Plants.

5. *Facility of Culture*.

6. *Size*.—The comparison in respect to size must not be absolute but relative, in those classes where mixed subjects compete together.

7. *Rarity and Intrinsic Value*.—Where specimens of one particular kind of plant—say Azaleas or Heaths—are brought together for adjudication, there is comparatively little difficulty in arriving at a correct decision by such stages as those indicated by the foregoing points; but it is not so easy to arrive at a satisfactory conclusion in the case of miscellaneous specimens when shown together in the same class, since the consideration of the value of the plant will obtrude itself, and will affect different minds in a different manner, according to peculiar tastes or fancies. Hence, at least special subjects, Orchids for example, which generally bear a high money value, should have separate classes assigned to them, and should not be left open to compete with such plants as Fuchsias, or even such as Ixoras, Allamandas, &c.

§ III. The considerations which should govern the award of prizes

to New Plants and Flowers—that is, subjects staged as novelties, have been already noted in a paper published in the first volume of the Society's Journal, but in order to present a more complete view of the subject, I will here briefly recapitulate what I have therein advanced.

(a). **FLOWERING PLANTS.**—The features which are the most desirable in a plant cultivated as a decorative object for the sake of its flowers—that is, in an ornamental-flowering plant viewed as a whole, are the following:—

1. *Free and Symmetrical Habit of Growth.*—Whether naturally slender or robust an ornamental plant should at least be free in the development of its parts, and should present something like regularity in its growth, so far as that can be realised in conjunction with its natural habit. The plant should not be of a stubborn immovable character, resulting in a stunted aspect, nor must it be of a delicate constitution, such as gardeners call "miffy." In a general way it should be compact and bushy, so far as its natural character permits—the opposite of lean and straggling in its mode of growth. Sometimes, it is true, a bad habit may be overcome by the skill of the cultivator, but it is better that a good habit should be inherent. Even in a climber, lanky long-jointed growth is not desirable.

2. *Profusion of Flowers well displayed.*—There should not only be an abundance of flowers produced, but they should be so disposed as to be effective; that is, they must not be hidden amongst the foliage, nor, if their beauty depends upon a view of their face, must they hang about loosely so that the face cannot be seen. If they are pendent, it should be with natural grace. They should not be crowded by foliage, nor crushed among themselves by being over-numerous or disadvantageously set on.

3. *Healthy Leaf-development.*—No plant can be really beautiful which has not well-grown and well-coloured healthy foliage; but the leaves should generally be subdued in comparison with the flowers, and must not in any case be disproportionately large or numerous. If the foliage is handsome, so much the better, but it must be healthy and wholesome-looking.

4. *Bright, pure, dense, or pleasingly-contrasted Colours.*—All dull dingy colours stamp a flower with inferiority, though they may sometimes be permitted as curiosities, especially if the flower is of some very remarkable form in its family, or presents some peculiar novelty.

5. *Form and Substance of Flowers and Embellishments.*—Unless flowers put on some of the best forms which their particular type may be capable of yielding, and are stout and durable in texture, they neither present the highest beauty of which they are capable, nor do their beauties, of whatever order, continue. Flimsy flowers soon perish, and are hence much inferior to those of stout enduring substance.

6. *Succession of Bloom.*—It is a greater merit to produce a succession of flowers, in order that the blooming season may be prolonged, provided they are not thereby rendered scanty and scattered, than to give a flush of flowers, the beauty of which is fleeting, and then not to blossom again for a considerable period. Next in merit to a plentiful succession of flowers comes a good head of bloom; and these plants are of the least value for ornamental purposes which only bear a few scattered blossoms at long intervals of time.

7. *Size of Flowers* is an advantage, all other points being equal; but size is apt to degenerate into coarseness, and hence it is not a feature to be estimated too highly.

8. *Distinctness.*—If it were not for the development of this characteristic, our flowers would lack half the charms they now have, owing to the almost endless variety they present; and hence this feature of distinctness should be made a *sine quâ non*. A new flower which has not appreciable distinctness has no advantage over the older ones which resemble it.

9. *Grateful Odour.*—A pleasant perfume is a great advantage in any flower, and must have its full weight in making any award to a new plant.

10. *Novelty.*—A decidedly new character is worth recognition in the absence of any other merit; for if the plant presenting it does not in other respects give us exactly what we desire, the new feature is to be regarded as the first step towards obtaining a new race; and to produce a new race is equivalent to the addition of a new province to the kingdom of Flora. If the new feature is some manifest improvement so much the better, but a new feature, though not in itself a direct and present advantage, may lead to something which is desirable. When, moreover, it is made an aim to develop, in connection with the novel character, the elements of beauty or utility, in which it may be deficient, this aim will in almost all cases be sooner or later realised, owing to the plasticity of vegetable development.

(b). **FOLIAGE PLANTS.**—In regard to plants grown for the sake of their foliage, many of the points of merit are the same as those sought for in flowering plants. The most desirable features appear to fall under the following heads:—

1. *Free and Symmetrical Habit of Growth.*—This feature is even more essential here than in the case of flowering plants, as great part of the beauty of the specimen necessarily depends upon it.

2. *Healthy Leaf-development.*—As the beauty of the plant is to be sought in its foliage, the leaves must at least be developed in a healthy and vigorous manner.

3. *Growfulness or Nobility of Aspect.*—Most of the plants grown for foliage alone are prized on account of one or other of these features. Hence a common-looking plant which does not possess either one or

the other, and does not yield showy flowers as a compensation, must be held to possess little merit from the decorative point of view, however curious or interesting it may be in other respects.

4. *Endurance of Foliage.*—When the beauty of the plant depends on the appearance presented by the foliage, it is obvious that the more enduring the character of that foliage, the longer will the plant retain its beauty. Hence endurance in the foliage becomes a very important quality. A deciduous plant is on this ground less valuable *per se* than an evergreen, although it may be good in its way, or in its season. But, then, evergreens and deciduous plants are not strictly comparable.

5. *Distinctness.*—When the beauty of a plant has to be sought in its leafage alone, there is much less scope for variety than when flowers are interspersed; but it becomes all the more essential to avoid the sameness of aspect which must prevail, if distinctness of character is not insisted on.

6. *Pleasing and Well-marked Colour.*—The leaf, that is to say, should, if green, be a good pleasant healthy-looking green, and if of any other colour, it should be of some decided and agreeable tint or tone.

7. *Well-defined Colours or Marblings.*—This is an essential part of beauty in the case of variegated leaves, and variegation is a condition commonly presented by what are called ornamental-foliaged plants. A cloudy intermixture of colours in leaves, as in flowers, is seldom or never effective.

8. *Novelty of Character.*—Though only to be valued as the stepping stone to the production of new races, as in the case of flowering plants, yet when combined with other elements of beauty, or as indicating features which may be improved upon and worked up to greater perfection, this is a property much to be desired.

It may here be observed that stove plants, greenhouse plants, and hardy plants require to be judged independently of each other. At first sight it might appear needless to estimate separately the merits of these several groups, since it might be said that hardy plants, the lowest in value intrinsically, stand really at an advantage in being suited to the means of a larger number of cultivators than would be able to accommodate hothouse plants, owing to the more costly nature of the conditions necessary to the successful production of the latter; while to some cultivators, who cannot command any such costly appliances, they would, of course, be all in all. On the whole, however, the several classes may be placed on an equality in so far as concerns the judgment on their merits as new plants; for whilst an advantage must be admitted in the case of the harder subject, on the ground of its more general applicability, an advantage must certainly be accorded to the hothouse plant on the ground of intrinsic value. But still I would urge the adoption of this rule, that plants of the classes denominated stove, greenhouse, and hardy, should be compared only among themselves. This limitation should indeed be carried further, for annuals, perennials, and shrubs or trees should in the same way only be compared amongst themselves; and of the latter, deciduous plants and evergreens can only be fairly compared with plants corresponding in character. The same may be said in reference to plants of any specially-marked group, such as Agaves or Orchids. To ascertain if a hardy Conifer was of first-class merit, it would be useless to compare it with a Fern or a Palm.

Further than this, plants adapted for blooming in the winter, or spring, or summer, or autumn seasons, must be judged in their relations to those particular seasons, and must not be rigidly compared except with those of their own season, because, in order to avoid a scarcity of flowers at any period, it is necessary to cultivate such as will extend the flowering period throughout the year. A plant may thus be really valuable on account of its blooming in winter, which would be regarded as comparatively worthless in summer, for the mere fact of producing blossoms during winter is sufficient to outweigh a multitude of minor defects. Hence may be deduced another conclusion—namely, that the rules by which new plants are judged must be relaxed in inverse proportion to the supply of flowers obtainable at the particular season at which they bloom. These general considerations must be allowed their full force in applying any set of rules for the determination of the merits of new plants.

(c). **FLORESTERS' FLOWERS.**—Though various in character, these admit of more ready and exact comparison than the subjects of the two preceding groups; for the number of organs to be adjudicated upon are fewer, and hence the requisite features admit of more exact comparison and definition, which definition has been already well worked out by florists. The features to be specially sought, and their relative value, are these:—

1. *Form.*—In most single flowers this should be circular, or, where the circle will not apply, symmetrical. In double flowers there should be a semi-globular outline. Compound flowers follow the same law as double flowers. Tubular flowers, and some others of peculiar form, offer exceptions, which can only be dealt with individually.

2. *Substance.*—The texture of the petals must be stout and dense if the flower is to be durable, for if flimsy it soon gives way, and loses both form and colour.

3. *Smoothness and Flatness of Edge and Surface.*—These qualities are eminently necessary to give refinement to the flower. A coarse rough-surfaced flower bears no comparison with one of a velvet-like smoothness and softness, and evenness of margin is equally necessary. A regular series of wart-like spots, as in the case of some Lilies, is,

however, admissible. In some cases, but not often, a well-developed fringe or frill is also admissible.

4. *Colour*.—This must be bright or pure and decided in self-flowers (that is, flowers of one colour), and clearly-defined and well-contrasted in striped or laced flowers.

5. *Fidelity of Colour* is a quality of some importance, and depends partly, but not wholly, on the texture or substance of the corolla.

6. *Proportion of Parts to the Whole* is an essential element of beauty, but, as this depends on the actual form, it must be defined individually in the different kinds of flowers.

7. *Size* is an advantage, so that it is not disproportionate nor conducive to coarseness, but it is very apt to degenerate into coarseness.

8. *Distinctness* is absolutely necessary for the sake of variety.

9. *Novelty* is a quality always welcome, as it enlarges the field of floriculture; but to count as a point in judging the change must not be a mere variation, but a decided difference of form or feature. The merit of any novelty of feature, moreover, must always be estimated subject to the higher qualities of form, substance, smoothness, proportion, &c.

§ IV. Cut flowers for competition are always shown in collections—*e.g.*, Roses, Carnations, Pansies, Gladioli, Hollyhocks, Asters, &c. Hence, many of the points advanced under the head of Plants staged in Collections (§ I.), apply to these also; but there are additional points, such as those advanced under New Florists' Flowers (§ III. c.), and over and beyond all these come in the special properties of each particular kind of flower. Time will not permit me to enter into detail on these points, and I will therefore merely mention those which are of general application, or nearly so:—

1. *Conformity with the Terms of the Schedule.*
2. *Freshness, and Unimpaired Condition.*
3. *Special Properties of the particular flower under judgment, and more particularly as regards:—Form, substance, smoothness of texture and margin, purity and definition in colour.*
4. *Variety.*

The only strictly accurate mode of judging is by allotting marks to each collection or plant in respect of each point of merit, and finally summing up the total. This may seem a tedious method of arriving at a result, but it need not be so in reality; and it is practically the method under which, by means of a mental process, our best judges arrive at their decisions. When this plan is adopted there is no guesswork, but the sum of the merits of a plant or a collection must come out accurately. I can only here briefly indicate how the method may be applied:—

In Section I., that is, Plants staged in Collections, the first point settles whether the collection is admissible or not—nonconformity with the schedule means disqualification. The other points must be gone over *seriatim*, and a decision arrived at whether each plant can be marked as good, bad, or indifferent, in respect to each point. As the points are not all equal I would allow double marks for the points of primary importance, and single marks for the secondary ones. Under the former good would be represented say by 6 marks, indifferent by 3 marks, bad by 1 mark. Under the latter good would stand at 3, indifferent at 2, bad at 1. With a little practice these numbers would be soon run out, even in a collection of a dozen or a score of plants, especially if prepared slips with columns for the different points were handed to the judges previous to their commencing their duties. I should put the points numbered 2, 3, 4, and 5 (health, freshness, beauty, compatibility), in the first category, and 6, 7, 8, and 9 (size, variety, facility of culture, rarity, and value) in the second, as regards collections of flowering plants; and 2, 3, and 4 (health, freshness, beauty) in the first, and 5, 6, and 7 (facility of culture, size, rarity) in the second category, as regards specimen plants. In this way the decisions in §§ I. and II., and even § IV may be very accurately made out, these groups being all competitive.

In the case of new plants the subjects require a different treatment, the object being to determine their intrinsic, not their comparative merit. Here, consequently, a fixed number, say 100, should indicate the highest degree of excellence, and any lesser number awarded will show the degree in which they approach this highest degree of merit. Practically those plants which gain 75 marks or upwards would be 1st class in merit; those which gain over 50 up to 75 would be 2nd class; and those which gain only from 30 to 50 would be 3rd class. In these cases the full number assigned to each meritorious feature is only to be awarded to the perfect condition of that feature, and any lesser proportionate number according to the actual degree of merit.

In reducing this to practice, the following would be the marks indicating the highest degrees of excellence in the case of New Flowering Plants:—

1. Freeness of habit	15	} = 100 marks.
2. Profuseness and display of flowers	15	
3. Healthiness of leaf-development	15	
4. Purity, brightness, or contrast of colour	10	
5. Endurance, substance, and form of flowers	10	
6. Succession of bloom	10	
7. Size of flower	10	
8. Distinctness of character	5	
9. Gratefulness of odour in leaves or flowers	5	
10. Novelty of a decided kind	5	

Glaring defects amongst new flowering plants would be presented by the undermentioned peculiarities, each of which should reduce the award by 10:—Straggling habit, flimsy flowers, muddled or dingy or fleeting colours, fetid odour.

The following is the scale proposed for New Foliage Plants:—

1. Freeness of habit	15	} = 100 marks.
2. Healthiness of leaf-development	15	
3. Gracefulness or nobility of aspect	15	
4. Endurance of foliage	15	
5. Distinctness of character	15	
6. Agreeableness of colouring	10	
7. Definition in markings	10	
8. Novelty	5	

As glaring defects which may occur in this class of plants, may be mentioned the following peculiarities, each of which should reduce the award by 10:—Straggling habit; flimsy, tender, rapidly perishing leaves; indistinct or fleeting colours or markings.

In the case of New Florists' Flowers, the points of excellence would bear the numerical ratio indicated below:—

1. Form	15	} = 100 marks.
2. Substance	15	
3. Smoothness	15	
4. Colour	10	
5. Fidelity of colour	10	
6. Proportion	10	
7. Size	10	
8. Distinctness	10	
9. Novelty	5	

The most glaring faults in this class of subjects are to be found in the following features, which are in most cases altogether incompatible with a high position:—Open eyes, as they are called, when double flowers show any part of the disc or centre; split petals or florets; run or confused or fading colours; roughness of outline or surface.

THE last paper which we shall give is that of Professor Lawson, which was read on the second day of the Congress.

OXFORD BOTANISTS.

HAVING been honoured with a request that I would write for this occasion a short paper, I chose for my subject "The History of the More Eminent Botanists and Gardeners connected with the County." But had I written my paper first, and then selected my title, instead of adopting the opposite course, I should have entitled it, "The History of the More Eminent Botanists and Gardeners connected with the University;" for when I came to examine the subject more closely, I found the amount of information that might be given was so great, that to do it justice I should require several papers in which to treat it, instead of one.

Thus I have to apologise for having departed in some degree from my original intention.

I will make use of this opportunity, and take the liberty of suggesting to the Committee the propriety of engaging, on each succeeding year, the services of some person well acquainted with the history of the city and neighbourhood in which their meeting may be held, who shall undertake to give us a short account of all who have advanced the botany or horticulture of their county. By these means we should gain a vast amount of valuable information that might otherwise be irretrievably lost; while many a name worthy of being chronicled would also be saved from oblivion.

The first item of interest connected with this place, to which I will now direct your attention, is the founding of the Botanic Gardens, by Henry Earl of Danby, in the year 1632.

This event established a new era in British botany; for, with the exception of a private physic garden belonging to Gerard in Holborn, none in England as yet had been set aside for scientific purposes.

Lord Danby obtained from Magdalen College a lease of nearly five acres of ground, which he surrounded with the present noble wall, and built the gateway that adorns the principal entrance to the gardens. He erected, also, greenhouses and stoves for exotics, and a house for the curator, Bobart, whom he appointed as the first curator. At his death, also, this generous nobleman added to his former liberality by bequeathing the rectory of Kirkdale in Yorkshire, from the funds of which he hoped to maintain the efficiency of the gardens, and secure the services of a professor.

Bobart, of whose name I have already made mention, was a German by birth, having been born at Brunswick. On his appointment as superintendent he set himself most industriously to fill the new gardens with all kinds of rare plants, both English and exotic; and in the year 1648 he published a catalogue in which he enumerates no less than 1600 species as having been grown by him at that time. Of these, however, many were doubtless only varieties; but even after allowing a liberal margin for them, the number must have been great for one man alone to have collected, in those days, in so short a time. Ten years afterwards he republished his catalogue, with the assistance of his son; Dr. Stephens, then a Fellow of New College, afterwards Principal of Magdalen Hall; and Mr. William Browne, who was afterwards Senior Fellow of Magdalen College. The number of species in this second list was greatly increased, but owing chiefly, it would appear, to a number of palpable varieties being raised to that rank. The great value of this work lies in the plan which was here first adopted, of quoting the synonyms of other authors, and of giving references to the pages of their works.

Jacob Bobart died at his house in the gardens, in the year 1679, at the advanced age of 81.

Although the gardens were begun in 1632, and Bobart appointed to them, Lord Danby's second intention of establishing a professorship

was not accomplished till the year 1669; owing partly to the unhappy state into which the country had fallen in those times, and partly owing to the insufficiency of the funds arising from the estate in Yorkshire. But in this year Dr. Robert Morison received from the University his appointment to the chair.

Morison was a Scotchman, born at Aberdeen in 1638. In that town also he received an education which it was intended should fit him for the Church. But finding the study of theology less in accordance with his tastes than that of physic, he fitted himself for that profession instead; and his reputation rose with such rapidity among the learned, that, before he was thirty years old, he was chosen by Charles II. as king's physician.

In his younger days he had espoused the Royal cause, and fought in the battle at Brigg, near Aberdeen, where he was dangerously wounded in the head. In consequence of this display of his loyalty he was compelled to fly from his native country and take refuge in France. While there he was brought under the notice of the Duke of Orleans, who, quickly perceiving his merit, appointed him superintendent of his gardens at Blois, and furnished him with the means of travelling through France, in order that he might collect plants and information.

During his stay in France he published a new edition of the "Hortus Bolesensis," in which he sets forth his new method of classification. From this work he gained much honour among the scientific men of the day; and it established his character as an original writer and thinker. On the restoration of Charles II. he returned to England, though earnestly solicited to remain where he was.

On his appointment to the professorship at Oxford he commenced a course of lectures, consisting of three every week during the summer and autumn terms. From this time to his death he occupied himself chiefly with the preparation of his "Historia Plantarum Oxoniensis." Of this work, however, he lived only to complete a portion, his life being cut short by an accident that happened to him while crossing a street in London. He died in the year 1683, and lies buried in the church of St. Martin-in-the-Fields, Westminster.

After Morison's death Jacob Bohart, son of the first carator, was appointed professor in his place. He finished the second volume of Morison's "Historia Plantarum," and in the preface of this book he gives an interesting account of all the botanical authors, both English and foreign, who had flourished up to that time. He appears to have been a man of some humour, for Dr. Gray, in his edition of "Hadibras," relates the following amusing story concerning him. He says:—"Mr. Smith, of Bedford, observes to me upon the word 'Dragon' as follows:—Mr. Jacob Bohart, Botany Professor of Oxford, did, about forty years ago, find a dead rat in the physic garden, which he made to resemble the common pictures of dragons, by altering its head and tail, and thrusting in taper sharp sticks, which distended the skin on each side till it mimicked wings. He let it dry as hard as possible. The learned immediately pronounced it a dragon: and one of them sent an accurate description of it to Dr. Malibechi, librarian to the Grand Duke of Tuscany. Several fine copies of verses were wrote on so rare a subject. But at last Mr. Bohart owned the cheat. However, it was looked upon as a masterpiece of art, and as such deposited in the museum, or anatomy school, where I saw it some years after."

Whether the Ashmolean Museum or Dr. Rolleston still possesses this variety I cannot say; but if not, I can, unfortunately, produce abundance of material from the same place, for any who may again be inclined to exercise their ingenuity. Bohart died in 1719, being 79 years old.

The next botanist of whom I have to speak is Dr. William Sherard, or Sherwood. This indefatigable worker and liberal patron was born at Bushby, in Leicestershire, in 1659. From the Merchant Taylors' School, where he laid the foundation of his knowledge, he matriculated at St. John's College; and in his twenty-fifth year was elected Fellow of the same Society. Leaving Oxford, he travelled as tutor to Lord Townsend, on the Continent, and there made such excellent collections as won for him the esteem and friendship of Ray. The encomiums passed upon him by this immortal naturalist served to increase his ardour, and we find him next making tours throughout England and the Channel Islands in search of new and rare plants, which were communicated to Ray for insertion in his "Synopsis Plantarum." About the year 1702 he was appointed consul at Smyrna, and the opportunity being thus offered him of collecting Eastern plants, he set himself with wonderful diligence to obtain all that were to be had from Naxos and Greece. These collections were the beginning of that magnificent Herbarium, which, with his Pinax, made his name to stand so high amongst botanists. After residing in Asia fifteen or sixteen years, he returned to England in 1718, when the University, in consideration of his learning, conferred upon him the degree of Doctor of Law.

Remaining in England a few years, he again visited the Continent, travelling through Holland, France, and Italy, renewing personal intercourse with his older friends, and making the acquaintance of those with whom he had before only corresponded. Amongst these latter stood Dillenius, for whom he soon learned to entertain so high a regard that he persuaded him to come over and cast in his lot with him in England. Here he directed his studies, urging him in particular to turn his attention to the cryptogamic portion of the vegetable kingdom—a class of plants that had as yet been greatly neglected, and, in consequence, but little understood. Although possessor of ample means that had been accumulated by him during his residence in Smyrna,

Sherard lived with the greatest contentment in London, devoting his whole time to the study and arrangement of his collections and the advancement of his Pinax. Shortly before he died he gave £500 to the Botanic Garden, for the enlargement of the conservatory, and otherwise testified to his zeal for botanical science, as well as to the love he bore for his "alma mater" by presenting to the gardens a great number of new and rare plants, and by endowing them with his curivalled collections of dried specimens, and with his library of botanical works, perfect for the time in which he lived.

On his death, in 1728, he left by will £300 to provide for a professor, stipulating that the University should add annually to that sum £150 for the maintenance of the garden and library, and that Dillenius, his friend, should be elected to the chair. The bargain was accepted by the University, and John Jacob Dillenius was elected professor. He was a native of Darmstadt, and was born in the year of our Lord 1687. He received his education at the University of Giessen, and practised in that city as physician, occupying himself also with the study of botany, and publishing the results of his observations in the "Miscellanea Curiosa" or the papers of the "Academia Curiosorum Germanica," a Society into which he was elected at a very early age. But the work that contributed mainly to bring him into notice was his "Catalogue of Plants growing in the neighbourhood of Giessen," published in the year 1719, and it was probably owing to this work that Sherard was led to form so high an opinion of him, and to desire so earnestly to gain his permanent assistance.

Of the manner in which Dillenius was persuaded by Sherard to leave his native land, and return with him to England in 1721, I have already spoken. His effort, after settling down in his adopted country, was a new edition of Ray's "Synopsis Stirpium Britannicarum," with some improvements of his own. During the life of Sherard he lived chiefly with him in London, or with his brother James Sherard, who had an estate at Eltham in Kent, and who took such pleasure in botany and horticulture, that his garden was said to be the richest of the time in England. While staying in this congenial place, Dillenius projected an illustrated description of all such plants as were new or rare growing in this garden, a work he afterwards published under the title of "Hortus Elthamensis." In this work he describes and figures with wonderful accuracy and faithfulness 417 plants, and quotes the synonyms of other authors.

In 1728 his friend and benefactor died, and he removed to Oxford, where he was chosen Professor of Botany in the University, according to the agreement made by Sherard. His first desire and highest ambition was thus realised. In 1736 Dillenius was visited by Linnæus, who was then a young man, and had been sent over by Clifford to collect plants for his garden in Holland. Dillenius, who had thoroughly imbibed the doctrines inculcated by Ray, had naturally no love for one who was, as he supposed, endeavouring to upset his system, by introducing a new one of his own. Consequently, it was with no very friendly feeling that he first made his acquaintance. But how long this unfriendliness lasted may be best inferred from the following passage, which I will quote from the "Diary of Linnæus." He says:—"In 1736 Linnæus went over to England at the expense of M. Clifford; and here he saw not only the gardens at Chelsea and Oxford, but also procured many of the rarest and nondescript plants sent thither. He likewise became acquainted with all the learned at that time in the kingdom. At Oxford, Linnæus was received in a friendly manner by Dr. Shaw, who had travelled in Barbary, and who declared himself a disciple of Linnæus, having read his system with great pleasure. The learned botanist, Dillenius, was at first haughty, conceiving Linnæus' 'Genera' (which he got half printed in Holland), to be written against himself. But he afterwards entertained him a month, without leaving Linnæus an hour to himself the whole day long; and at last took leave of him with tears in his eyes, after having given him the choice of living with him till his death, as the salary of the professorship was sufficient for them both."

Can anything be more touching than this description of the change of sentiment that Dillenius manifested towards the young man he had at first looked upon as an innovator, and one personally hostile to himself? But although the feelings of respect and dislike were so completely obliterated that others of admiration and affection took their place, still Dillenius never adopted Linnæus' views, but remained constant to the system of Ray.

There is another version of this story current, that makes Linnæus appear in company with Sherard. According to this account, Sherard received him with affability, Dillenius with coldness, the latter remarking in English to Sherard, "This is the young fellow who is putting all botanists and all botany into confusion." Linnæus, for a time, took no notice of this unmannerly remark, the meaning of which he gathered from the way Dillenius pronounced the word "confusion;" but after he had explained away some difficulties respecting the "Linaria Cymbalaria," which neither Sherard nor Dillenius had been able to do, he revenged himself by saying quietly, he hoped he had not brought "confusion" into the Botanic Gardens at Oxford. Dillenius blushed, and apologised for his expression.

There is no reason for disbelieving the correctness of this story, only we must substitute the name of Dr. Shaw for that of Sherard, for Linnæus did not visit England till 1736, eight years after Sherard's death.

All this while Dillenius had been collecting material, and investigating the class Cryptogamia, making considerable excursions into

Wales and other parts of the country in search of new species, more especially of Mosses; and when the publication of his "Hortus Elthamensis" had furnished him with more leisure, he gave his whole attention to this particular branch of botany, and in the year 1741 he gave to the world that excellent digest of his labours, the "Historia Mnscoomm."

Six years after the publication of this work he was seized with a fit of apoplexy, which ended his life on April 2nd, 1747, at the comparatively early age of 60.

Dillenius was succeeded in the professorship by Dr. Humphrey Sibthorp, of Magdalen College, who continued in possession of the chair till the year 1784, when he made way for his illustrious son, Dr. John Sibthorp, of Lincoln College. This gentleman is well known for his labours in the European Flora. He made two excursions into the East of Europe, collecting and describing, and with the assistance of Ferdinand Bauer, the celebrated draughtsman, illustrating by the most beautiful drawings everything of interest in natural history; and before his death, which took place, alas! in the year 1796, when he was but 38 years old, he had prepared for publication those wonderful monuments of perseverance and learning, his "Flora Græca," and "Fanna Græca." Stricken down with consumption, induced by a cold caught when on his travels, he died after a short illness at Bath. After his death it was found that he had left in his will £300 a-year to defray, first the expenses of his "Flora Græca," and after its completion to found a Professorship in Rural Economy, and to furnish funds for making additions to the herbarium and library. The successor to Dr. Sibthorp was Dr. George Williams of Corpus Christi College. During his lifetime many preparations were made for the improvement of the gardens. The lower parts, which during rains, used to be flooded, were raised a considerable height, and this led the way for the changes that were effected by Dr. Daubeny, who succeeded to the chair on the death of Dr. Williams in 1834.

Dr. Charles Giles Bridel Daubeny was born at Stratton, in Gloucestershire, in 1735. From the school at Winchester, where he remained six years, he went, in his 20th year, to Magdalen College, where he obtained, first a "demyship," and afterwards a fellowship. After taking his degree, he sought to extend his experience by studying at other universities, and for this purpose went to London and Edinburgh, and afterwards at Geneva attended a course of De Candolle's lectures on botany, of which he took the most ample and elaborate notes.

One of his earliest works, and one of which his reputation as a great philosopher may fairly rest, was his "History of Volcanos." Into this work he compressed a wonderful amount of original information; and, notwithstanding the gigantic strides geology has made since then, it is one that may be read with the greatest profit at the present day.

In 1822 he was elected Professor of Chemistry, and in 1834 Professor of Botany. The first of these chairs he held till 1865, when he resigned it in favour of the present professor. Of the changes that Dr. Daubeny effected on his appointment it is difficult to speak too favourably. In the place of the old herbarium and library he built the present dwelling-house, while he removed the herbarium to a new and more commodious building on the north side of the gardens, away from the river. The garden itself, too, was entirely remodelled, the rabbits that infested its walks routed out, and the garden laid out partly on the natural system and partly on the Linnaean. The improvements that were made during both Professor Williams's time and Dr. Daubeny's were conducted entirely by Mr. Baxter, sen., and his son, Mr. William H. Baxter, who together have for the last 57 years devoted their whole time with the greatest ability to their accomplishment; and with what success they have laboured I am not permitted to speak, but I leave it for you discerning gentlemen to inspect the gardens, and judge for yourselves. The greater number of the present conservatories also are the result of Dr. Daubeny's indefatigable exertions. In all matters relating to horticulture or agriculture he took, as most of you will remember, the deepest interest. For the furtherance of both he purchased a piece of ground in the parish of Hilley, with the intention of carrying on experiments with different kinds of manures; and this ground he caused to be conveyed to the University, to be held in trust by them for the use of the Professor of Rural Economy. For some years, however, before his death his health was such as to prevent his undertaking any fresh experiments, so he let it, and when he died it had run into great disorder.

Dr. Daubeny was one of the earliest supporters of the British Association, and in 1856 he presided over its deliberations at Cheltenham; and so great was his popularity there, that a medal was struck in his honour to commemorate the occasion—a tribute of respect that has never been paid to any other president by his friends and admirers.

It would be beside my purpose in this paper to enlarge upon other matters than such as are purely botanical; but I cannot before concluding refrain from drawing your attention to the fact that Dr. Daubeny was one of the earliest and strongest supporters of scientific instruction being given in this University. With but few sympathisers on his side he did battle for a natural science school, at a time when its introduction was dreaded by the majority of his contemporaries. But he lived to see his early dreams realised, and before he died he had the satisfaction of beholding a young but flourishing school, with ample opportunities for teaching, and an efficient staff of professors

and tutors labouring in all its various branches. What he aided in establishing it is our part to maintain; and you, I am sure, will wish us "God speed."

ROYAL HORTICULTURAL SOCIETY.

AUGUST 17TH.

ALTHOUGH one of the minor Shows, this was advanced to the dignity of being held in the conservatory instead of the Council-room, as every one expected. It deserved the distinction. It was not a large show, it was not a remarkable show, but it was a good show, and a good show under adverse circumstances. Who is there not calling out owing to the drought? Very few, and fortunate they; and it was a marvel to see such stands of *Gladiolus* as were shown by Messrs. Kelway, Messrs. Downie, and Messrs. Buoyard among nurserymen; by Mr. Fry, Mr. Douglas, and the Rev. H. Dombraïn. Happy may they be in their well-earned honours, for even in the best of soils, in the best of situations, with the best of means, and with abundance of water, many could not have nearly approached the excellence in which these exhibited their favourite flowers. It was, too, an exhibition in all senses satisfactory; it was well arranged—*gay, gracefully arranged*, for along the centres of the tables were lordly Tree Ferns, *Campanulas*, and miscellaneous plants, which relieved the fatness stands of florists' flowers generally have. There were groups every so far giving diversity amidst the long lines of the regular tabling, bearing a variety of beautiful subjects. There were exhibitors well pleased (a rarity), and there were sight-seers well pleased too, but of the last there were not enough; for fine as the day was, fine as the show, London is now out of town. We have given great credit to the *Gladiolus* exhibitors; those of the Hollyhock equally deserve a word of praise, but we missed one well-known name, that of the Rev. E. Hawke, of Willingham Rectory—a name that will ever be connected with the Hollyhock, as the place will with Jeannie Deans. But there were many other things to interest—the *Phloxes*, neglected too much, but yet so beautiful *en masse*, or individually; the ornamental-leaved trees and shrubs from Messrs. Paul & Son, affording the means of diversifying the scenery of our pleasure grounds and parks; and, last, there was ample store of those novelties for which the advanced horticulturist is ever seeking, and that in many ways. The whole formed one of the best of the minor shows; it might have been better, but better it could hardly have been under the circumstances. The details we subjoin.

In Class I, for foreign growers, there was no exhibition, as might indeed be expected in the present disturbed state of the Continent. In the nurserymen's class for thirty-six Messrs. Kelway & Son, Langport, were first with magnificent spikes of *Molire*, Madame Vilmorin, *Spectabilis*, *Le Titien*, *Rosa Bonheur*, *Freemason*, *Madame Desportes*, *Robert Fortune*, *Agnes Mary*, *James Veitch*, *Elizabeth*, *Meyerbeer*, *Duc de Montebello*, *Prince Imperial*, *De Humboldt*, *Schiller*, *Newton*, *Lacépède*, *Legouvé*, *Velleda*, *Engue*, *Scribe*, *Formosa*, *Rossini*, *Stella*, *Norma*, *Virgile*, *Mathilde de Landevoisin*, *Leonora*, *Orphée*, *Monsieur A. Brongniart*, *Sultane*, *Van Dyck*, *Canova*, *Auna*, *Noémie*, and *Homère*. The spikes in this stand were all fastened to brass rails running longitudinally, which made them stand well up, and, being placed about 9 inches apart, the effect of the collection was much better than where the spikes were more crowded. No second prize was awarded, and the third prize went to Mr. D. Robertson, Heleusburgh, Dumbarton. The spikes in this collection were much inferior to those in the first prize one and to those in a collection from Messrs. Bunyard, of Ashford and Maidstone, which would have been second had it not been too late for competition.

Class 3 was for eighteen spikes. In this Messrs. Downie, Laird, and Laing, of Stanstead Park Nursery, were first with splendid spikes, though not on the whole equal to those shown by Messrs. Kelway in the preceding class. The varieties were *Madame Lesclé*, *Hortense*, *Le Ponsin*, *Canova*, *Orphée*, *Madame Bieder*, *Fulton*, *Lacépède*, *Sultan*, *Norma*, *Horace*, *Milton*, *Alexandra*, *Crystal Palace*, *Diomedé*, *Meyerbeer*, and *Shakspeare*. The second prize went to Messrs. Draycott & Sons, Humberstone Nursery, Leicester, who had excellent spikes of *Shakspeare*, *Imperatrice Eugénie*, *James Veitch*, *Madame Furtado*, *Sir William Hooker*, and some others. Messrs. Paul & Son were third; but Messrs. Stuart & Mein, Kelso, who sent noble spikes of *Princess Mary of Cambridge*, *Rossini*, *Armide*, *Monsieur Legouvé*, and *Maria Stuart*, and very good ones of several others, if not too late for competition would have taken a high position.

In the amateurs' class for twelve, Mr. R. Fry, gardener to V. Stuckey, Esq., Tannton, had an excellent stand in which *Shakspeare*, *Madame Vilmorin*, *Legouvé*, *Charles Turner*, *Norma*, and *Mathilde de Landevoisin* were the most prominent. For this and a stand from the Rev. H. H. Dombraïn, Westwell Vicarage, Ashford, equal first prizes were given. The latter had fine spikes of *Leonora*, *Madame Dombraïn*, *Madame Furtado*, *Orphée*, *Eleanor Norman*, *Rosa Bonheur*, *Mario Stuart*, *Homère*, *James Veitch*, and *Roi Leopold*. Mr. J. Douglas, gardener to F. Whitbourn, Esq., Loxford Hall, was second with *Delicatissima*, well named, being flushed with delicate pinkish lilac; *Orphée*, *Princess of Wales*, and good spikes of several other kinds.

For nine spikes, Mr. R. Fry was again first with excellent spikes, Mr. Douglas being second, and the Rev. H. H. Dombraïn third; and of six spikes, Mr. Welch, gardener to J. Marshall, Esq., Belmont Park, Tannton, was the only exhibitor, and took a first prize. For four, Mr. Fry was first with very fine spikes of *Lacépède*, *Robert Fortune*,

Anna, and De Humboldt; the Rev. H. H. Dombrain being second; his varieties were Rosa Bonheur, Agathe, Madame Desportes, and Elizabeth, all being good.

Hollyhocks, though not numerous shown, were very good, especially for such a dry season. For six ent spikes Mr. W. Chater, of Saffron Walden, was first with fine spikes with very perfect flowers, the varieties being Fascination, Conquest, Eclipse, salmon rose, very large and fine; Cygnet, white; Scarlet Gem, and Frederick Chater, ruby. Messrs. Downie, Laird, & Laing were second with Mrs. Downie, Alexander Henderson, Lady W. W. Wyne, Queen of Yellows, Miss Henderson, a lovely flower, and John McDonald. The third prize went to Mr. Minchin, The Nurseries, Hook Norton, who had Frederick Chater very fine, and good spikes of several others.

The best twenty-four cut blooms came from Mr. W. Chater, and were well worthy of his reputation, being very perfect:—Fanny Chater, beautiful rose; Conquest; King, cream colour, tipped with lilac rose. Midnight, Scarlet Gem, Champion, Bullion, Walden Primrose, Talisman, Alfred Chater, Jewel Conquest (ruby), Leviathan, Leah, Alfred Chater, Mochanna, Crimson King were very fine. The tipped kinds are quite ladies' flowers. Mr. Minchin was second, and Messrs. Draycott third, each with excellent blooms. The only exhibitor of twelve blooms was Mr. Minchin, who had a first prize.

Phloxes looked rather rough as cut blooms; we would prefer to see them shown on the plants, which would also give a better idea of the habit. Messrs. Downie, Laird, & Laing were first with La Duchesse de Bauffremont, Triomphe du Parc de Neuilly, very fine and free-flowering; La Candeur, Monsieur William Bull, Monsieur Charles Turner, Monsieur Hugh Low, lovely colour; Madame Domage, Joseph Heim, Magnificent, and Gloire de Neuilly, the latter very brilliant. Messrs. E. G. Henderson were second; Souvenir de Berryer, Louis Warrich, Diomede, and Hermine de Turenne were very attractive. The third prize went to Messrs. Paul & Son, who had also some very fine varieties. To those who know how ornamental this flower is, it is somewhat surprising it is not more extensively cultivated.

Of miscellaneous groups, one from Messrs. Arthur Henderson and Co., of the Pine Apple Place Nurseries, contained numerous small specimens of Palms, such as *Malortia speciosa*, *Calamus accidens*, a graceful species; *Euterpe sylvestris*, *Livistonia rotundifolia*, *Hypophorbe Verschaffeltii*; *Ferns*; the pretty, free-flowering, and very useful *Begonia weltoniensis*; and *Draenas*. In a group from the Society's gardens accompanying that of Messrs. A. Henderson was *Trachelium caruleum*, an old but very ornamental plant, nearly hardy, and producing a profusion of heads of bluish lavender flowers. The same plant is freely introduced in the baskets in the conservatory and with excellent effect. Mr. B. S. Williams, of Holloway, had a very effective group, in which was a remarkably fine specimen of *Allamanda Hendersonii*; *Cochlostema Jacobianum* with two heads of its beautiful flowers; *Mitonia Morelliana atrovirens*, a very fine variety; numerous *Acrides*; *Dendrobium triadenum*, with a head of small white flowers tinged with lilac, and having a small rich yellow blotch at the base of the lip; *Cypripedium Stonei*; new *Draenas*; *Yucca filamentosa variegata*, very fine; *Billbergias*; *Antherium Scherzerianum*, with fourteen spathes, most of them expanded; several fine *Pithech Plants*; *Ferns*, and a handsome specimen of *Phœnicophorium seehellarii*, and *Nerine eouscans major*, an old but showy plant now but seldom seen.

Messrs. F. & A. Smith sent a fine collection of Balsams, and several plants of the showy *Rochea falcata*. Mr. Bull, of Chelsea, also contributed an interesting group, in which were a double Tiger Lily, the extremely handsome *Encephalartos* shown by him lately, several Palms, *Draenas*, Orchids, the singular *Godwinia gigas*, fully noticed some time ago in our pages, and some other plants.

Messrs. Paul & Son, of Chesham, sent a small collection of pot Roses, stands of cut blooms, and an extensive and interesting collection of cut specimens of hardy trees and shrubs, with ornamental foliage. Messrs. Draycott, Humberstone Nurseries, and Mr. Walker, nurseryman, Thame, sent good collections of double Zinnias, and Mr. Walker sent a very good stand of Dahlias.

FRUIT COMMITTEE.—George F. Wilson, Esq., F.R.S., in the chair. Mr. Stew, of Farnborough, near Bromley, sent specimens of a seedling Black Currant, which was exhibited at last meeting, and also specimens of Black Naples, to show that the seedling was not the same variety; but the Black Naples shown were very inferior examples of that variety, and the Committee confirmed the previous opinion. Mr. Dry, of Hayes, Middlesex, sent a seedling Plum, called Duke of Edinburgh, a handsome purple Plum, with a thick blue bloom. It is a freestone, with yellow flesh, and judging from the branch which was sent, it appears to be very prolific. It was awarded a first-class certificate. Mr. Porter, gardener to E. Benham, Esq., Sten Lodge, Isleworth, sent a dish of Prince of Wales Plum. Mr. Porter also exhibited a dish of Hawthornden, and another variety unnamed. Mr. Tillery, of Welbeck, sent a dish of Barrington Peaches, large and handsome, and of delicious flavour, to which a special certificate was awarded.

Of Apricots, Moorpark, from Mr. Tillery, gardener to the Duke of Portland, Welbeck, was first; Mr. Gardiner, Lower Ealington Park, Stratford-on-Avon, being second, and Mr. Smith, gardener to the Earl of Gainsborough, Hexton Park, third.

Mr. Pearson, of Chilwell, sent a bunch of a seedling Grape, called Chilwell White, which, as Mr. Pearson observed, he intended as a white companion to the Black Hamburgh. It produces a fine berry, with a short, stout, warted berry stalk; the skin membranous, though not thick, and the flavour of the flesh like that of Black Hamburgh. This was awarded a first-class certificate. Mr. Pearson also exhibited a bunch of Ferdinand Lesseps, raised by crossing Royal Muscadine with the Strawberry Grape, in which the flavour of the latter is distinctly traceable. The bunches are nearly as large as those of Royal Muscadine, and the berries quite as large, of a fine deep amber colour, and the flavour particularly rich, with a fine perfume. It was awarded a first-class certificate. Mr. Record, of Lillesden, sent a dish of very large and handsome Morello Cherries, which received a special certificate. Messrs. Rolleston, of Tooting, sent a collection of fifteen different sorts of Crabs.

Messrs. Carter & Co. sent pans of a new salad called Chinese Mustard, which is a distinct sort from the ordinary Mustard. The seed is black and as large as that of the White Mustard, and quite different from the common Black Mustard. The flavour of the salad is more pungent than common Mustard, and by some thought to be more agreeable. Seed was sent to Chiswick to be grown, and the salad to be exhibited at next meeting. Mr. Tillery, of Welbeck, sent specimens of the White Turkey Cucumber. Mr. Record, of Lillesden, sent dishes of Giant King Potato, a large second early and very prolific. Messrs. Carter and Co. again exhibited large specimens of the Italian White Tripoli Onion. A collection of vegetables was sent by Mr. G. Bloomfield, gardener to W. Williams, Esq., Parkside, Wimbledon. Messrs. Harrison & Son, of Leicester, sent a brace of Black Spine Cucumbers.

Mr. Ward, gardener to T. N. Miller, Esq., Bishop Stortford, sent four magnificent Charlotte Rothschild Pines, weighing 38 lbs. collectively. They received a special certificate.

FLORAL COMMITTEE.—Rev. Joshua Dix in the chair. Messrs. Cripps, nurserymen, of Taunbridge Wells, received a first-class certificate for *Clematis Victoria*, a remarkably fine purplish variety; and a similar award was made to Messrs. Baker & Son, Bagshot, for *Clematis Gem*, small, but distinct in colour, a bluish lavender. Messrs. Cripps also sent a variety of *Catalpa siringifolia* with golden leaves, which, it was stated, had been exposed to the sun, and became improved in colour, while in the shade it reverted to the normal green. From G. F. Wilson, Esq., came *Lilium longiflorum albe-marginatum*, quite white, which received a first-class certificate; his handsome namesake, *Lilium Wilsoni*; the still more beautiful true *Lilium speciosum* being also shown by the same gentleman, an ardent lover of the Lilies, and one who can grow them well. It is a marvel to us that such flowers, with such a poetry, with such fragrance, such loveliness, are not more cultivated now.

Mr. Porter, gardener to E. Benham, Esq., Isleworth, had a second-class certificate for Hollyhock Rose Queen. Mr. Bull, of Chelsea, received a first-class certificate for *Lilium tigrinum splendens*, a remarkably fine variety; also for *Cureuligo recurvata variegata*, broadly striped with white, a very fine variegated plant. The same exhibitor also sent *Geonoma Verschaffeltii*, *Lomaria auriculata*, and other interesting plants.

From Messrs. E. G. Henderson & Sons, Wellington Nurseries, St. John's Wood, came *Pteris serrulata gleicheniifolia*, a beautiful, small-leaved Fern, which received a first-class certificate.

Mr. Wheeler, Bath, was awarded a first-class certificate for *Dahlia Marchioness of Bath*, white, tipped with purplish rose, and of fine form. Mr. Williams, of Holloway, received a first-class certificate for *Ladia*, or *Cattleya*, *elegans gigantea*, a very fine variety. He also exhibited *Ixora Williamsii*, a plant which promises to be very fine for exhibition purposes, and *Maranta Barquinii*.

Mr. Cannell, of Woolwich, had a first-class certificate for double *Pelargonium Crown Prince*, of the same colour as *Marie Lemoine*, and apparently not so good.

Mr. Perry, Castle Bromwich, sent a stand of his fine seedling *Verbenas*, of which Mrs. Boulton, with large pips, white, with a purplish crimson eye, was awarded a first-class certificate. Mr. Eckford, gardener to the Earl of Radnor, Coleshill, had first-class certificates for *Verbenas Grand Monarch* and *George Peabody*, the first a fine scarlet, the second plum with a white eye. Mr. George, gardener to Miss Nicholson, Putney Heath, had a special certificate for a collection of cut Zonal *Pelargoniums*. Mr. Williams, Crystal Palace, Sydenham, sent a fine golden variety of *Lilium auratum*; Messrs. Carter & Co., fine cut blooms of *Marigolds*, French and African, a double-headed *Love-lies-Bleeding*, and a white *Lupine*. Mr. Minchin, Hook Norton, sent some fine *Hollyhocks*, which were not, however, considered an advance on existing varieties; Mr. Walker, Thame, seedling *Dahlia*; Mr. W. G. Smith, *Boletus calophas*, *B. edulis*, *B. subtomentosus*, and *Lactarius oxuccus*, which, however fine the specimens, were by no means appetising. From the Society's gardens came cut branches of a *Gleditsia*, which, we believe, furnishes some of the much-vaunted cattle foods.

GENERAL MEETING.—W. Marshall, Esq., in the chair. The Rev. M. J. Berkeley in addressing the meeting called special attention to Mr. Williams's *Cattleya* already noticed, to the beautiful *Dendrobium triadenum* shown also by the same exhibitor, and to *Rodriguezia snaveolens*, which, he said, was the same as *Gomesa recurva* of Loddiges'

"Botanical Cabinet." the true plant being figured in the "Botanical Magazine" under the name of *Pleurothallis snavcolens*. The variegated *Carex recurva* from Mr. Bull was a plant well worthy of notice. With regard to *Lilium Wilsoni*, it had at one time been supposed to be the same as *Lilium Thunbergianum*, but the two had been found to be perfectly distinct. The golden *Catalpa syringifolia* had been awarded a first-class certificate. Many other plants had exhibited a similar character this year, and this might be rendered permanent by grafting. The Dodder on the Clover was next referred to in connection with a curious parasite on a Heath, and one of the species of *Cuscuta*, it was stated, attacked the Vine. With regard to the Onions shown, he had been informed that what had been supposed to be the early variety of the Tripoli was that of which the seed had been procured from Naples, whilst the later variety was raised from seed ripened in colder parts. Mr. Berkeley then referred to some abnormal specimens of Gourds he had lately had submitted to him, which were covered with warts, which had the rudiments of leaves, but in which he could discover no rudiments of flowers; and in those varieties of Gourds called Bush Squashes he had noticed this season a tendency to develop an infinity of blossoms without fruit.

NEGLECTED PLANTS.

CANARINA CAMPANULATA.—This fine old greenhouse herbaceous perennial, which was introduced as far back as 1696, is now very rarely met with indeed. Last spring I saw a large specimen of it, covered with its numerous orange-coloured, bell-shaped flowers, and growing in a small conservatory, apparently receiving no extra care, and yet doing as well as the most ardent cultivator could desire to see it. As it blooms early in the winter and spring, it dies down in May, and the plant is then put out of doors in some shady place to rest. In August young growth appears breaking-up from the root, like that which comes from a Dahlia, and the young shoots, if taken off, can be struck in a similar manner to the cuttings of the Dahlia. As it will not stand the slightest frost, it must be removed to a greenhouse ere frost sets in; and here the plant will make its growth, and flower before Christmas. Like the Dahlia, it will do with generous treatment: a good fibry loam, enriched with some manure, and helped with some sand, would suit it well. It is one of those neglected plants that richly deserve a much more extended cultivation, and the example referred to above I saw at Redbridge, near Southampton, the residence of Mr. William Stride. The fine condition of the plant was highly creditable to the gardener, Mr. Davis.

ZEPHYRANTHES ROSEA.—It seems scarcely possible to believe that this beautiful half-hardy bulb should have to be classed with the neglected plants, but so rarely is it now seen that the conclusion is inevitable. It cannot be because it is difficult to cultivate, for Mr. Baines, gardener to H. L. Micholls, Esq., formerly of Manchester, at whose new residence—Southgate Park, near London—I recently saw it in bloom, says it is difficult to kill it; and, as it was here developed, I can conceive nothing more suitable for conservatory decoration at this season of the year. It remains in bloom quite two months; and when in bloom, it should be kept shaded to prolong the duration of the flowers; previously to that, it should have plenty of light and air. The ordinary treatment of the hardy kinds of *Amaryllidaceae* plants would appear to suit it well.

ANOMATHECA CRUENTA.—This is another somewhat neglected plant, though more frequently met with than either of the preceding. I also saw this at Southgate Park, growing in the same pot with the *Zephyranthes*, as well as in the pots of other *Amaryllids*. Mr. Baines stated he encouraged it to grow in this fashion as much as possible, by sowing the seed, and sprinkling it over the surface of the pots. The seed grows readily, and in this somewhat irregular way a good many pretty dull crimson flowers are thus secured to cut from. It is also capable of being cultivated out of doors, and will bloom in borders, or planted in some soil made up of sandy peat. It is a bulbous-rooted plant, with an *Ixia*-like appearance of growth, and it can be increased by offsets as well as by seed.—R. D.—*(The Gardener.)*

WEEDS.

EVERY weed allowed to arrive at maturity with any crop is a diminution of the yield; it impoverishes the soil as much as a cultivated plant. Wheat, Barley, and Oats do not exhaust the soil more than Couch, Bent, or Rib-grass. Land in which these are plentiful will produce good crops of one or other of the former. The same holds good of the more succulent weeds, as Groundsel, Chickweed, and Charlock. Docks, Thistles, and

Dandelions take quite as much nutriment from the soil as Mangold Wurtzel, Turnips, and other root crops. It is an acknowledged fact that land rank with natural vegetation is capable of the highest cultivation; it will produce in perfection some one of the many plants necessary for the comfort of man. Land by nature sterile forms but a very insignificant portion of the earth's surface; except, perhaps, the sands in the interior of Africa and other quarters of the globe, there is but little of its surface not teeming with vegetable life, on which man directly and indirectly is dependent for his sustenance. He must, therefore, look well to the proper cultivation of the ground. He must select, not only the plants most suitable to the soil, but those which will afford him the greatest return. All soils have constituents suited to the growth of plants of more or less value to man. The natural vegetation may be Couch, Bent, and other coarse Grasses, but, as already stated, such ground will grow most, if not all, of the cereals. By breaking up the natural vegetation, and freeing the ground of that which is of little worth, it is made suitable for the growth of plants of considerably greater value.

Uncultivated soils are in course of time enriched by the plants growing on them decaying year by year, increasing the depth of the soil and adding to its fertility. Uncultivated plants return to the soil quite as much, if not more, than is taken from it, but cultivated plants impoverish the soil, because their produce, for instance in grain and straw, is taken away, and there is no annual deposit of vegetable matter except by weeds. Every crop is exhausting, and the soil soon becomes worn out, for no one crop can for any long period be profitably grown on the same soil. Hence the desirability of a change of soil—a rotation of crops. We must not only afford a change of soil, but we must return to the soil what the crop takes from it. This is effected by manuring.

Whilst vegetable matter, which we have in the decayed natural vegetation, is necessary for the fertility of the soil, the removal of such matter does not cause sterility if due regard be paid to the application of manures. Weeds, then, are of no value in cultivated soil; they appropriate that which ought to go to nourish the crop, and diminish production without returning an adequate equivalent. The great advance made in the art of culture is one of the boasts of our generation. Various implements for breaking up the soil, giving increased depth of soil, exposing it to the influence of the atmosphere, and producing a better tilth for the reception of the seed, have done much in enabling us to obtain better crops; they have also assisted in freeing the ground of weeds. Sowing in drills has likewise afforded greater facilities for the cutting-up of weeds; and, as regards root crops, this is so well carried out that many fields would compare advantageously with some gardens. Fields of Wheat, however, may be seen red with Poppies, and Oats and Barley a mass of yellow from the quantity of Charlock, to say nothing of the Thistles, Docks, and Plantains; at a prominent in every meadow and pasture; and what of the Groundsel, Chickweed, and other annual or biennial weeds which undisturbed attain maturity with every cereal crop? The weeds, along with a portion of their seeds, must be harvested with the crop, and some must remain among the grain however well it may be cleaned, and a still greater portion will find its way with the straw to the manure heap, and ultimately to the soil again. In this way weeds are propagated.—G. ABBEY.

(To be continued.)

FLORAL ICE HOUSES IN NEW YORK.

THE present has been one of the most trying seasons known in this latitude for a great number of years, the thermometer having frequently risen above 100° in the shade, and seldom fallen below 85° day or night for the last four weeks (I write on July 27th), and being frequently up to 92° by eight o'clock in the morning. Think of that, ye floral devotees. How long would your pets exist in such a temperature? A bud in the morning is a full-blown flower by midday, and rapidly forming a seed vessel by night. This unusually heated term has caused a great amount of loss to those who deal extensively in cut flowers in this city, from the rapid depreciation in value of their stock in trade; but one, at least, of our spirited business men has been equal to the occasion. Mr. Walter Reid, one of our most enterprising city florists, has had a miniature ice house constructed in the rear of his store, and so arranged that he can raise or lower the temperature at will. There he can keep Rose buds, Tuberoses, Gardenias, &c., fresh for a week if

necessary, instead of becoming stale and unsaleable a few hours after getting them on hand. Mr. Reid is the son of Mr. Robert Reid, lately a florist in this city, and for many years a judge at Chiswick in its palmyest days, and he has now his father's

certificate of membership of the Royal Horticultural Society, framed and hung up in his store, with the Duke of Devonshire's signature and the Society's seal attached—perhaps the only thing of the sort in America.—DAVID FOULIS, *New York.*

DESIGN FOR A FOUNTAIN.

The design represented in the accompanying engraving is entirely of iron, the centre-piece and spouts throwing out a

beautiful series of water jets. The fountain is a beautiful specimen of ornamental ironwork for lawn and garden pur-

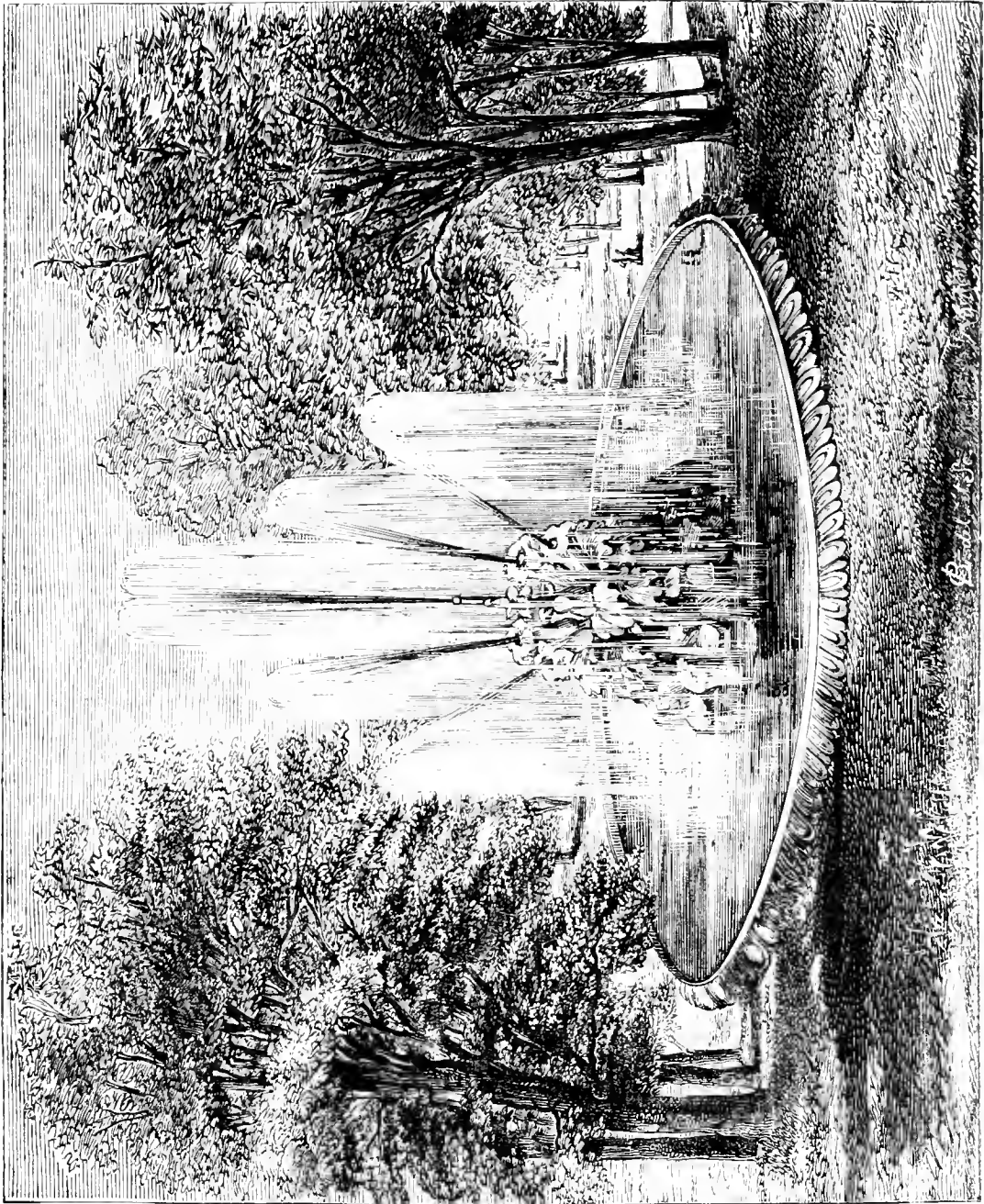

poses. The use of architectural and iron ornamental work in and around our suburban villa grounds is becoming more and more extensive, and in truth is necessary to help out to the full the pleasure and tasteful enjoyment of rural life.—(*Horticulturist*)

BEDDING PLANTS IN 1870.

As this has been an exceptional season for bedding plants, I send a few notes, which may be of interest to some of your readers.

I have always been an advocate for early planting, combined

with early preparation, of bedding plants, and this year has more than ever confirmed my views on this subject, for, with hardly any exception, in every garden which has come under my notice this year, those plants which were backward or put out late have done no good, while those which were put out early as good established plants have stood the dry weather and done admirably. And in this view I am confirmed in a letter from A. O. Walker, Esq., of Chester, who says that he has never seen bedding plants finer where they were planted out early, and that those planted late have done no good whatever.

This year I was living in Gloucestershire at bedding-out time, and I had all the beds planted and the garden finished by the 26th of May; and though from that time through the whole of June there was only one shower of rain, I never allowed any of the Geranium beds to be watered; the only beds which had any water were Verbenas and Calceolarias. We left there late in June, and I have been twice there since, and although the lawn was burnt up as brown as a high road, and the leaves were falling from the Elm trees as if it had been October, the last time I was there, about the 3rd of August, the Geranium beds were still good, especially Waltham Seedling and Indian Yellow; the only useless one, which I have long given up here, being *Christino*. Lord Palmerston was splendid in the middle of July, but had over-flowered, and the exceeding heat and drought, in Gloucestershire, of the last week in July were beginning to tell upon it.

Here, in Yorkshire, we began to bed out about the 16th of May, and planted everything but Coleus and Indian Maize by the end of the month; these were put in the first week in June. The Indian Maize, grown from a cob of English-ripened seed sent me by Dr. Hogg, has done very well.

It has been too hot and dry for the Coleus, which was planted under the front wall of the house, but the plants are growing well still, and I expect will get a good colour when the sun has less power; but as the thermometer laid on the grass in the sun has frequently registered over 120°—this very day, August 12th, being over 120° for two or three hours consecutively—it seems to burn the colour out of the leaves, and to give them a rusty hue. It is almost impossible in a stove to give them too much light, but there the moist atmosphere prevents the sun blanching them.

Beet has done well with me where the sparrows will leave it alone; but they have proved a great enemy to it this dry summer when they are short of insects, and they get under the shade of the leaves and peck the juicy stems to pieces, hardly ever touching the leaves themselves, but destroying the stems completely. In a wet season the plants would have grown away from them, but this dry season they have done the plants in places a great deal of injury.

Iresine Lindenii will, I think, be a valuable acquisition in a less trying season. It has stood the dry weather pretty fairly; but as we have now had only 0.33, or the third of an inch of rain, since the 30th of June, and the last few days have been hotter and drier, if possible, than ever, ranging from 75° to 86° in the shade, with a north-easterly wind, they are beginning to succumb, and as I can only afford water for Verbena beds, I am afraid if rain do not come very soon that they will hardly recover. Even Indian Corn is beginning to flag now, and *Perilla* is suffering worse than *Iresine*.

My Verbenas, especially mixed Verbenas, have been splendid this year, but I have watered them regularly—not mere surface watering, but copiously, and the plants cover the surface of the beds so entirely that there is comparatively very little evaporation now. There were some very good sorts among the new ones of last year, especially *Monarch*, *Emma Perry*, *Sunny Thoughts*, *Peacemaker*, *Out-and-Out*, *Mrs. R. Hole*, &c. I do not, in fact, ever remember a much better lot of seedlings being sent out by Mr. Perry. Of older sorts, *James Birbeck* and *Miss Wimssett* have been remarkably good, and a chance seedling, a cross between *Crimson King* and *Foxhunter*, which I bedded on trial, has proved an effective bedder.

Calceolarias have not done well with me; I have used this year more *Tagetes signata pumila* than *Calceolaria*, but intend another year to go back to the *Calceolaria* again. Two beds of *Tagetes* have been very good, but a row of *Tagetes* was too near some *Arabis variegata*, which was a harbour for slugs, and several plants were destroyed, and the blanks had to be filled up from reserves, so that the rows were uneven. *Tagetes* also comes in too late to please me, so that I shall plant more *Calceolarias* another year, though I think the colour is rather too gaudy and striking to use much of, especially in masses, as there is

no relief to the eye in a large bed of yellow *Calceolarias* if in full bloom. As a row in a ribbon border it is more appropriate, and certainly there is no yellow to equal it in point of richness of colour. All yellow-foliated plants are really only yellow greens, but as such are very useful, notably *Pyrethrum Golden Feather*, which is certainly one of our most valuable additions to the garden, its only drawback being its tendency to flower, which can, however, be kept under by judicious cutting, and seedlings are much less troublesome than cuttings, especially if the centre be well cut back at the first appearance of a flower bud.

Lobelia Little Gem has been beautiful with me this year. Those who do not possess it should certainly give it a trial. The colour is much the same as that of *Paxtoni*, but it is much more dwarf, and has the invaluable habit of making plenty of leaf and growth before flowering, so that when turned out in spring it forms, under proper treatment, masses of dense foliage. I pricked out mine in the middle of March under light frames, such as I have previously described in the pages of your Journal, and transplanted them with balls, and I have not seen a single failure in those planted early; but some which were planted out later to take the place of some seedling *Lobelia speciosa* which had not done well, died after flowering. Those which were planted early are still blooming profusely, and likely to continue some time longer, though they have been in full bloom now for more than eight weeks, and most of the plants were blooming when put out in May.

Another plant for edgings which always does well with me, and is not, I think, sufficiently used, is the large-leaved variegated *Periwinkle* (*Vinca*). Its leaves are always bright, and it stands both wet and drought; it has a straggling habit, but is easily pegged down and kept in, and it can be pegged by means of its own shoots. If one of the long trailing stems be buried on one side, then drawn over the plant, and buried again on the other, both of the ends will root, and the plant may thus be made to keep itself trained.

I will defer my remarks on Geraniums till another time, as it would make these present notes too long. I will only add about them at present, that with me the *Nosegays* have again been much the best, William Underwood having been the only good Zonal which can at all compare with such sorts as *Violet Hill*, *Bayard*, *Waltham Seedling*, *Indian Yellow*, *Duchess of Sutherland*, &c. *Violet Hill* seems still the very best I have seen, and in this opinion I am confirmed by every gardener who has seen it here this year. It is nearly as good now, when other Geraniums are suffering from the dry weather, as ever, and the beds have never had a drop of water given to them since they were planted; and I am more and more convinced, that the best way to treat Geraniums is to get sorts that will bear manure and rich treatment without growing coarse; then, if dry weather come, they have the manure to support them, and if wet weather, from their dwarfer growth and freer habit of blooming they will not go to leaf, even under good treatment, so much as the older sorts of strong-growing Zonals, as *Clipper*, *Dr. Lindley*, *Lord Derby*, *Herald of Spring*, &c., and in dry seasons they do not run to seed or shed their petals as the Zonals do. I forgot to say that in Gloucestershire *Iresine Herbstii* has stood the dry weather admirably, and grown vigorously, though the colour is not so rich as in damp, warm weather.—C. P. PEACH, *Appleton-le-Street*.

AFTER experiencing a wet and somewhat sunless spring and fore-summer in this part of the country, we are now undergoing a roasting process much more severe than that to which we were subjected last season, and it may be interesting as well as useful to note how different bedding plants are enduring it.

To begin at the beginning, for they are undoubtedly the alpha of the bedding alphabet, *Pelargoniums* are mostly doing well. The principal exceptions are *Golden Fleece*, *Cloth of Gold*, and some of the new bronze sorts. The first two were beautiful so long as the dripping weather lasted, but now many of their leaves are turning up round the edges and crumbling away into dry dust. Why they should do so when others of the white sorts with just as little green in their leaves, such as *Castlemilk* for example, stand uninjured, will most likely remain one of the many unanswered whys which are continually meeting us. Perhaps it may be that the leaves of the latter, being white, reflect the sun's rays, while the yellow leaves, being able to do so only in an inferior degree, are sunstruck and shrivel up; or perhaps it may be from a totally different cause; but one thing is certain, that those two of the golden names cannot be trusted to behave themselves when planted where they are fully exposed

to the sun. Some of the larger leaves of Mrs. Pollock are also similarly affected, but otherwise this oldest and best of bedding Tricolors is at present wearing her brightest colours. That pretty, variegated, Ivy-leaved Geranium L'Élegante seems to find its way but slowly over the country, yet it is really one of the most delicate and quietly artistic plants I know either for edgings or for carpeting under tall-growing plants, and it is never more beautiful than during weather such as this.

Calceolarias are giving much trouble in watering and stuffing short grass among them, but in return they are blooming most profusely, and promising well for the rest of the season, except *Aurea floribunda*, whose beauty threatens soon to be a thing of the past. This fine Calceolaria will not succeed in dry light soils without more work being expended upon it than even it is worth. In the beginning of May, while they were growing in Celery trenches, the Calceolarias suffered rather severely from what was to me a rather novel cause, the tops of many of them being destroyed by a curious shield-shaped insect called *Pentatoma baccharum*, which lives on the sap of plants, piercing the soft tissues for the purpose of extracting it, and literally sucking them to death. I have long known them as preying upon the tops of Potatoes, Beans, &c., though not previously upon Calceolarias, but they have never appeared in such numbers here as they did last spring.

Many of our new, and, in point of flower, best Verbenas seem utterly incapable of enduring any great hardship. It would appear that the improving process has well-nigh ruined their constitutions; but this is, all the world over, one of the ills incidental to a highly artificial state. Even we, in ceasing to be savages, have had to make considerable sacrifices. Many of them, while refusing point-blank to grow upon a dry-dust regimen, likewise take offence at the daily waterings necessary to keep them moist, let the water be never so scientifically applied, and make little more progress than if it were one of the coldest of seasons. Fortunately they are not all alike, and there are plenty to choose from, and for decorative purposes very few gardeners really require more than four or five sorts, including *Verbena venosa*, which ought to be everywhere.

Viola cornuta that was planted in April is still passable, but old edgings of last year's planting are done. *V. lutea* does not succeed here. The yellow and blue bedding Pansies have also begun to look seedy.

The much-vanished Golden Feather *Pyrethrum* is most un-sightly wherever I have seen it during the last three weeks. There can be no doubt as to its proper place being the spring garden, where there are no Calceolarias to outshine it, but long before the dog-days it ought to be on the rubbish heap. The variegated *Polemonium* is doing well, with liberal waterings, and is, as everybody knows, a most beautiful edging plant, but how does it happen that though it is universally known as *P. cereuleum variegatum*, yet the flowers are invariably white, at least all those that I have seen?

Petunias, *Gazanias*, and *Gaillardias* are doing well. *Gaillardia coccinea* is quite an effective bedding plant when grown from cuttings, from seed it is rather late in beginning to bloom. —AVESHIRE GARDENER.

METROPOLITAN SOCIETY'S EXHIBITION AT THE CRYSTAL PALACE.

MAY I use this channel of communication to answer a good many letters that I have received on the subject of the exhibition to be held on the 6th, 7th, and 8th of September? And first of all to thank the very many kind friends (for friends they are, although many of them unknown to me), whose letters strew my table, for the kind and cheery words of encouragement that they give me, and for the offers of assistance ungrudgingly made. It is, I can safely say, a matter to me of deep gratitude that not only these have been given, but that I have been so implicitly trusted in all the arrangements for the show. To be told by one that "the Society is the very thing that is wanted, and that it is sure to be popular;" by another, one of our most distinguished florists, "I have been asked to go to Ireland, but have declined, as I want to stay and help you;" by another, one of our most ardent amateurs, that "I am quite willing to give you any assistance in my power," is indeed cheering, and these are but samples of many that I have received.

"What are our prospects of a good show?" Well, far better than I could have anticipated. We commence operations in probably the most trying season for florists' flowers the present

generation has known, and yet withal, from the entries already received, I feel convinced we shall have a good exhibition. The time has now come when the florists can testify whether they are able to hold their own, and I sincerely trust they will give one and all a hearty pull in this matter. I can promise them, as far as I am concerned, there shall be nothing but fair and open dealing, and that we know no party. We bury the hatchet of all past differences, and welcome all who desire to encourage florists' flowers.—D., Deal.

"REDCARRE, A POOR FYSHER TOWNE."—No. 3.

SAUNTERING southward along the unexcelled sands for a short three miles, the four bathing machines of the village of Marske are reached, and on a lofty cliff-point above stands forth the goodly mansion of Joseph Pease, Esq. It seems bare, and needing plantations of sea-defying trees to nestle among; and high and exposed though it is to all the gales from every point of the east, I think some of the trees enumerated not long since in your columns as successful settlers on our sea-shores would maintain their good character here, and they deserve the trial, and the mansion deserves their success. When the cliff is climbed, and a peep obtained over the garden wall, there is evidence—special evidence—of provision made for shelter against the rough cold winds which sweep over the cliff. A deep sheltering valley is cut, with turfed sloping banks on either side, and at the bottom of the valley are flower borders with a broad gravelled walk between.

I am a wanderer just now, and my thoughts, like my steps, are vagrant, and you will so think when you read my next jotting—the name of Pease led to the query, Is that the correct plural of Pea? I think it is not. A correspondent in *Notes and Queries* recently remonstrated against such a plural form, and truly observed that if admitted, then the plural of sea might be "sease." I think that "Pease" was formerly the singular. At all events, Phillips in his "World of Words," published in 1678, so used it. He says, "*Pease* (Pisum), a sort of pulse of a most pleasing savor, and at the first coming accounted a great rarity. That sort called *Pease Everlasting* hath a very fine flower or blossom, and is called in Latin *Lathyrus*; the *Wood* or *Heath Pease*, *Astragalus*." "Pease" might have been used both as a singular and plural noun, just as we use fish and sheep; but I remember that "Peason" was one plural form, but being away from my books I cannot detail the when and where it was so.

"Here is the smugglers' grave," said an old man in the graveyard which crowns the cliff opposite to Mr. Pease's house. "They was drown'd by their boat's upsetting, but the scription's clean gone." "Not quite," I observed, "here are the commencements of five lines—H—, Franci—, Ka—, W—, K—. Then the sculptured figures on this headstone are of a man carrying a woman on his back, and a girl by another man's side. The boat upset is plain enough, but I interpret that the four drowned were Francis some one and Katherine his wife, and William some one and Katherine his daughter." My old guide "never knew the like," and so we parted; but as I made a circuit, facing me was a monument to the memory of the Earl of Zetland's gardener, Henry Yarker, and Hester his wife. Strange is it that, go where I will, something about horticulture is sure to confront me. My next move was on to Saltburn, and the first book handed to me by a bookseller in answer to my inquiry for a book on plants, was the seventeenth volume of THE JOURNAL OF HORTICULTURE!

Well, without any prelude I have passed on to Saltburn, and turning to notes previously taken at the British Museum, I find this extract from the Cotton MS. quoted in my previous communication:—

"At Saltburne Mouth a smale brooke dischargeth ytsel into the sea, which lyinge lowe under the banks, serveth as a trunk or conduite to convey the rumor of the sea into the neighbour fieldes; for when all wyndes are whiste, and the sea restes unmoved as a standing poole, sometymes there is such a horrible groninge heard from that creake at the least six myles in the mayne lande. that the fishermen dare not put forth, though thyrste of gaine drive them on, houlding an opinion that the sea, as a greedy beaste ravinge for hunger, desyers to be satisfied with men's carcasses."

The sea must have changed its diet since that was written, for I could not meet with any one that had heard its carcass-coveting "groninge." The "smale brooke," now travels quietly and deviously to the sea, between precipitous and

wooded cliffs, with broad varied surfaces below, and a fourth of a mile in length, affording the most beautiful site for a garden I ever traversed. It is laid out as a garden, and not a suggestion can I offer to improve its plan; the terraced walks, mostly under thickly shading trees, the seats, the alcove, are all judiciously placed, and the flower beds, croquet ground, and bedding-out at the extreme end near Mr. Bell's residence, Rushpool Hall, are well-arranged and well-cultivated; but the other portions of this "Happy Valley" are most offensively neglected and overwhelmed with weeds. I expressed my regret and surprise, but was met with the reply, puzzling to the most astute Chancellor of the Exchequer—"We have no funds." This should not be, and I venture to prognosticate will not long be, for visitors must increase in number, and if the inhabitants would raise a fund and open a subscription, there would surely be a sum annually subscribed worthily to sustain a garden capable of being made one of the most beautiful in England.—G

DEATH OF MR. JOHN GOULD VEITCH.

It is not yet twelve months since we recorded the lamented death of Mr. James Veitch, of Chelsea. It is now our painful duty to announce that of his eldest son, John Gould Veitch, a young man of great promise, at the early age of thirty-one. He was born in the nurseries at Mount Radford, near Exeter, April 17th, 1839, and died at the nurseries, Coombe Wood, near Kingston-on-Thames, on the evening of Saturday last.

At an early age Mr. John Gould Veitch took an active part in the management of the nurseries at Chelsea, and so early as 1861, when only twenty-one years of age, became one of its travelling collectors, and proceeded to China and Japan. He at the same time visited the Philippine Islands, and during that expedition he discovered and sent home many plants that now form important features in our gardens and horticultural exhibitions. He returned home for the Great Industrial Exhibition of 1862; and again left for the Southern Pacific in 1864, landing at Sydney, and afterwards proceeding as far north as Cape York and the Gulf of Carpentaria. He returned early in 1866, and shortly after his marriage, in February, 1867, he was attacked by a severe disease of the lungs, which has necessitated his wintering in the south of Europe for the last two years, and it has been by extreme care that his life has been preserved so long. On the Tuesday preceding his death Mr. J. G. Veitch visited Chelsea, and exhibited the greatest interest when he went over the whole of that vast establishment, and the same evening, on his return to Coombe Wood, he had a relapse of his complaint; and hæmorrhage of the lungs having set in, he gradually became worse till he sank on Saturday night through pure exhaustion. Thus died a young man of great ability, singular kindness of heart, and loved and esteemed by all who enjoyed the pleasure of his friendship. The funeral will take place in Brompton Cemetery this day, and the service will be performed by the Rev. Joshua Dix, of All-Hallows, Friday Street.

Among the numerous plants which Mr. J. G. Veitch discovered and sent home from his expeditions we may mention *Lilium auratum*, *Sciadopitys verticillata*, *Raphiolepis ovata*, various species of *Retinosporas* and *Osmantus*; *Abies firma*, *Alecoquiana*, *microsperma*, *polita*, and *Veitchii*; *Cryptomeria elegans*, *Ampelopsis Veitchii* and *japonica*; the handsome *Palm Veitchii* *Johanna*, *Juniperus rigida*, many sorts of *Bambusas* and *Ancubas*, *Cyrtopodium lævigatum*, and large quantities of the valuable Orchids *Vanda Batemanni* and *Dendrobium bigibbum*, which, however, had been introduced before, but were rare in Europe. Of *Crotons* he sent no less than twenty-three distinct kinds, and of *Dracenas* twelve or fourteen, among which were *Regina*, *Mooreana*, *Chelsoni*, and *Macleayi*. The beautiful *Phormium tenax variegatum* he sent in large quantities, and also the charming *Pandanus Veitchii*. The now popular *Acalypha tricolor* and *Amaranthus melancholicus ruber* were also of his introduction, and a new *Amaranthus* not yet sent out, called *salicifolius*. Then there were *Alocasia zebрина*, *Phyllanthus variegatus*, *Colens Veitchii* and *Gibsoni*, a number of fine *Lycopods* not yet sent out; these and many more, of which it is unnecessary to extend the list, were among the botanical treasures this indefatigable young man added to our collections during his short but brilliant career.

NOTES AND GLEANINGS.

A CORRESPONDENT writes to us remonstrating against what he calls "the pedantic use of the word PELARGONIUM AS

APPLIED TO THE OLD SCARLET GERANIUM class of flowers. Bedding or Scarlet Geraniums they were always called, and what necessity is there for calling them otherwise? We speak of Tall and Dwarf Nasturtiums, *Laurus Tinus*, *Althæa frutex*, and *Rose Acacia*, although they do not severally belong botanically to the genera *Nasturtium*, *Laurus*, *Althæa*, or *Acacia*. And why, then, this raid against our old favourite popular name of—Scarlet Geranium?" There is no doubt that the sudden adoption of the name *Pelargonium* in popular speaking and writing does startle old-fashioned and non-botanical gardeners. It was after visiting Mr. William Paul's Rose Show at the Crystal Palace a few months ago, we were returning to town in the railway train, and a lady and gentleman occupied seats in the same carriage with us. The gentleman had procured a copy of Mr. Paul's nursery catalogue at the show, and was carefully perusing it, when he ejaculated, "Pe-lar-gon-i-ums! What are Pe-lar-gon-i-ums? Do you know?" and the lady addressed confessed her ignorance. "Whatever they are, there are plenty of them," said the gentleman, and the subject dropped. Now, in all probability the name of Scarlet Geranium was well known to both. We confess to a weakness in favour of the old name when used popularly. It is like calling an old friend by his pet name after he has been ennobled.

— UNDER the name of CHINESE MUSTARD Messrs. Carter and Co., of Holborn, have sent us a pot of "small salad." In the form in which we have received it, the plant is stout and succulent, apparently more so than the ordinary Mustard, and possesses an agreeable though a powerful pungency. The seed which accompanied the pot is black, and much larger than that of the ordinary Black Mustard.

WORK FOR THE WEEK.

KITCHEN GARDEN.

THE *Celery* and most of the *Endive* being planted, the cultivation of the ground between growing winter crops should proceed in fair weather. This is a good time to plant *Hautbois Strawberries* about 6 or 8 inches apart in beds. Those planted earlier are apt to blossom in the autumn. Let all runners be trimmed off the Alpines, and slates placed under the plants. Cut all hard or bursting *Cabbages*, in order to secure a good crop of early sprouts on the stools to face the winter. Let late *Kidney Beans* be well earthed-up to protect them against storms, and top or pinch all inclined to assume a running character. In gathering *Kidney Beans*, good cultivators pick the old with the young at all gatherings, whether of use or not. It is astonishing how a few large or ripening pods will exhaust the plant, and hinder succession. The *Onions* which were laid down a fortnight ago should be removed forthwith to a gravel walk, and the ground well manured, and planted with late *Colerworts*; these will be very useful. *Shallots* should be housed directly; these require a warm and dry room, where they will often keep till May, or they will keep for a long period suspended in a Cabbage-net in a kitchen.

FLOWER GARDEN.

Those who are fond of early annuals, whether in pots in the mixed greenhouse, or in the flower garden, should sow soon. Stocks and Mignonette should be sown forthwith; the latter may be sown in a warm border and transplanted into well-drained pots, treating them with much care for a week afterwards. The Moss and Provence Roses for forcing should now be all turned round, if plunged, in order to break the roots through the bottoms of the pots; at the same time let all gross sucker-shoots be cut away. The filling-up of blanks, staking and tying-up, mowing, cleaning, and rolling, will, of course, go on as usual. Lose no time in putting-in an abundance of cuttings of flowers for next year's masses. *Auriculas* may now be repotted. All decayed leaves should be removed, but this must be done carefully, otherwise more injury will be sustained by the plant than many people imagine. In potting, should the plant appear at all unhealthy, carefully remove the soil without breaking the ball, and examine the tap root. Should this be decayed or cankered, as is sometimes the case, it must be cut completely away. Avoid all complicated stimulating composts, for, however, fine the plants may grow, the health of the stock will be jeopardised. Well-decayed leaves, with turfy loam, will form a good compost for wintering the plants in. Many Tulip bulbs, from the serious check they experienced last blooming season, and which reduced in numerous in-

stances their bulk one-half, will require to be moved from the situation they hold in the best bed, as they will not bloom satisfactorily, and their places filled from the reserve beds or other quarters with bulbs which will bloom in similar character, so that the uniformity of the collection may be maintained. Pay strict attention to the soil for the ensuing planting season, turning it over occasionally in order to sweeten it. Continue to put out Pink pipings, and attend to the directions given last week relative to potting the layers of Carnations and Picotees. Pansies will now strike very freely, and when the weather is suitable plant out seedlings in beds of rich-prepared compost. Examine Ranunculus roots, being careful that they do not contract damp, and pay strict attention to Dahlias, which now require much care. Young shoots may be struck in brisk heat, and the regular routine of tying, disbudding, &c., must be persevered in, not forgetting to carry on continual war against earwigs and all destructive insects.

GREENHOUSE AND CONSERVATORY.

The time has now arrived when plants intended to supply a floral display under glass during autumn and winter must have attention. Let Begonias have another shift if not already in pots sufficiently large. Keep the plants thin that their foliage may be preserved from injury. *Crowea saligna* and *Plumbago capensis* are both valuable autumn-blooming plants, and the latter furnishes large supplies of cut flowers. Attend to *Chrysanthemums*, and water freely with liquid manure; good specimens should be aimed at rather than a few fine blooms. The earliest winter-flowering Heaths and Epacrises must soon be placed under glass, as it will forward their blooming. The appearance of bulb catalogues, too, tells us that Hyacinths and Narcissus for forcing must soon occupy attention. About equal portions of good loam and decayed leaf mould, with silver sand, will be the best soil for them if for forcing, but well-decomposed cow dung must be substituted for the leaf soil when the bulbs are intended for late flowering. After potting place them on a dry bottom, and cover the pots 2 or 3 inches deep with old tan or ashes, preserving them at the same time as much as possible from heavy rains; under this treatment they will fill their pots with roots, and will be in readiness for forcing when wanted. Van Thol Tulips for forcing may be potted early next month. Place them on coal ashes, cover them as recommended for Hyacinths, and early in November remove them into heat; the principal bulk need not be potted until late in October, and a last batch of *Tournefortia* or *Rex Rubrorum* towards the end of November. Where conservatory borders or beds exist, see that they are duly watered. Examine the plants individually, as their wants will be various. Arrangements must be made forthwith for housing tender plants. There is in many cases no necessity to have them all in at once; let it be done progressively, according to their wants. A few of the more showy annuals, such as the *Collinsias*, *Clarkias*, *Leptosiphon*, *Erysimum*, *Iberis*, *Lasthenia*, *Eutoca*, *Nolana*, and *Calandrinia*, may be sown now in pots and kept in cold frames through the winter. They will serve to decorate the shelves of the mixed greenhouse early in spring, as well as to enliven the early flower beds or borders. A nice turfy loam, rather old, will be better than rich composts, the object being to obtain a stiff and healthy plant, capable of enduring a hard winter. There will also be more colour in proportion to the amount of foliage—a most important matter in the cultivation of annuals. Where valuable stove plants have been kept in the conservatory in bloom, they will require careful management to prevent their being injured by damp, and they must not be overwatered at the root, as stove plants are soon injured by a low temperature if the soil is kept too wet. Give air freely in bright days, but if the house contains many stove plants, it will be advisable to shut up rather early in the afternoon, so as to retain a little warmth for the night; and in the event of wet, cloudy weather continuing, it will probably be found necessary in old-fashioned, badly-glazed houses to use a little fire heat to preserve the blossoms of tender plants, and this should be seen to before handsome specimens become disfigured or ruined for the season, for those in bloom are not over-plentiful in most places, and are therefore worth caring for. Keep everything in this house as clean and neat as possible, removing decayed leaves and flowers immediately they are perceived.

STOVE.

Ripen growths for the winter, day by day. Continue to increase the amount of air in general, and to slightly decrease the amount of atmospheric moisture. Examine pot specimens

frequently, turning them partly round in order to expose all their sides equally to light and air.—W. KEANE.

DOINGS OF THE LAST WEEK.

We had a slight rain for a short time on the 7th and 10th inst., but not enough to do more than moisten the surface a little, without placing anything appreciable in tanks or reservoirs. Better harvest weather there could not be, as even these showers and some heavy dews helped to swell the grains of corn. For everything growing the weather has been most trying. The drizzling rain on the forenoon of the 10th helped to refresh the foliage, and until the moisture at the surface was evaporated the foliage felt the benefit of the vapour as it passed upwards. But, singular to say, the plants thus refreshed suffered greatly from the bright sun of the following day—far more than they did in the bright days before the refreshing shower came. We account for it on the principle frequently alluded to—that the surface-damping before it was quite evaporated prevented the roots absorbing moisture from beneath, and thus they were unable at first to meet the rapid evaporation of the foliage when the sun shone brightly, and the surface moisture was nearly evaporated. Those placed under similar circumstances, who watched such results on a large scale, would be taught the impropriety of resorting to mere surface-watering, and that it was in general better not to water than so to water as not to reach the bulk of the roots.

KITCHEN GARDEN.

Artichokes.—The Jerusalem Artichoke, with its tubers, and the Globe Artichoke, with its rough heads, have suffered much with us, though both were mulched, and the latter once well watered with sewage. The former, like our Hollyhocks, have such short stems that they will suffer little from high winds this season; the latter, though yielding a fair produce in the first part of the season, look now as if the autumn produce would be scanty indeed—a matter of importance where such things are much in demand.

Asparagus and *Sea-kale* never looked more healthy, though watering them was quite out of the question, but a slight salting about May has helped to keep the ground moister than it would otherwise have been.

Autumn Peas, we fear, will be thin and scarce, notwithstanding all our trouble; but Dwarf Kidney Beans and Scarlet Runners are abundant, though in some cases suffering from the dryness.

We sowed Spinach, Tripoli Onions, Radishes, Turnips, and Lettuces in well-pulverised soil, but to the depth of at least 18 inches it was so dry that sowing in the usual way would have been seed and labour thrown away. There could be no vegetation until there was a good heavy rain, and we may yet wait a long time for it. All the vegetables named were sown in rather deep drills for the seed, the drills having previously been well drenched with sewage put on twice at a short interval between the applications. In about an hour the surface of the watered drill was sufficiently dried to permit sowing, and then the seeds were slightly covered with the dry soil at the sides. This encourages germination at once, and the rootlets have something to entice them to go down.

Cauliflowers.—Until lately we never had better, larger, more compact heads; but the heat and the dry air are becoming rather too much, many of the heads losing compactness, and coming like loose Sprouting Broccoli. Even a fair watering with sewage has not in a good many cases arrested this evil. In hot, dry summers August and the first half of September are the most difficult times to obtain fine, compact Cauliflowers. Partly on this account we like to gather all for preserving and pickling early. In the cooler times—towards the end of autumn, the Cauliflowers will again be close and crisp. A dripping, rather shady summer suits the Cauliflower best.

Potatoes.—All the early kinds have proved extra fine, prolific, and clean. With us the later kinds will be smaller than usual, especially where, from crowding, they scarcely had justice. It was astonishing to find such masses of tubers in soil so dry that it might have come from a hot oven. In many cases the small feeding fibres had gone to a good depth. A few tubers have commenced growing again, a sure sign that they will do no more good by remaining. We noticed this among a few of the Walnut-leaved Kidney, and had them taken up forthwith, as they are ripe enough. Still, but for the above, we would have given them a week or ten days more to make the tubers more mealy.

Most of such ground, though very dry, we have planted with

Broccoli and Winter Greens, watering the plants well first, letting them stand a little in a pot of thinish mud, planting them out in drills, and soaking each plant with sewage. We are alluding to those planted with the dibber. Those pricked out previously were carefully watered and lifted with balls. Those dibbled out are looking better than could have been expected, but they will grow slowly until we have duller and damper weather.

We find from several notes that this season will force many like ourselves to make arrangements for securing a larger water supply in summer. In most districts plenty of water falls, if part of it could only be secured for summer use. No doubt draining has been serviceable to the land, but if nothing is thought about except disposing of the water, we may make our fields next to barren from dryness if we have no stored-up supply from the drainage. It is possible to carry a good principle too far. One or two facts, or seeming facts, are worth mentioning for consideration.

The first is, that though all fine-pointed matter when fully exposed to a clear sky becomes rapidly cooled, and therefore a good condenser of vapour near it, yet it seems that even in this respect there is a difference in the condensing power of comparatively dried, inert points and the points of living substances. For instance, we have repeatedly noticed this season that after a clear starry night the exposed places of our brownish short-cropped lawns, and the larger bent grass on the quite-as-brown park, would be so destitute of dew that the finest satin slipper of a lady would not be damped; in fact, so far as the feeling of the hand went, no moisture whatever could be detected, whilst in a few places where the grass, from some peculiar circumstance, remained green, there you might have washed your hands in dewdrops. It would not be fair from such limited observation to deduce an inference, or we would say that the inference would be that it is possible to make land so dry that the grass on it may become so withered as to be unable to condense for itself the fair amount of dew to which otherwise it would have been entitled. As another fact bearing on this subject, we may mention that this hot summer we have frequently noticed that healthy, flourishing plants in flower beds would be slightly dewed in the morning, whilst the short, brownish lawn around them was perfectly dry.

One other fact is worthy of consideration and observation. The rains this summer have been something like deluges in some places, and mere drizzles in others. We have frequently seen the rains fall heavily only a few miles off, whilst we had not enough to damp the mere surface. We do not here speak so much from facts as a kind of belief from observation, that there seems to be an attraction between a dampish soil and a watery cloud; so much so, that the cloud will sail past the dry soil, and shed its resources on that which is damper. If there should be any truth in such an inference, then extra draining without husbanding may not only leave a scarcity of water, but may prevent such drained land obtaining its due share of moisture from the clouds. In such a fitful season as this, as respects moisture, it would be well worth observing and noting whether highly-drained land or the reverse had received the greater amount of rainfall.

In the enthusiasm for improvement it is just possible to make fields too large, and to leave too few trees standing. We know of places quite changed in this respect. Where small fields and meadows with hedgerow timber made the country look like a forest from a distance, all is now open, and scarcely a tree is to be found. We have no doubt that such districts are now very different as respects moisture. Every tree not only absorbs moisture, but it is a first-rate collector. When, after clear nights, our brownish lawns were almost dust-dry, it would not have been difficult to have collected barrowloads of mud from beneath some large Ashes and Beeches. The time may come, if such seasons as this continue, when, instead of rooting out every tree from cultivated lands, such as hedgerows, we may be forced to plant again in order to obtain moisture-distillers. The more pointed and healthy the foliage, the more will be its condensing power. One morning, with the brownish grass in the park almost quite dry, a large Beech tree was sending quite a shower of sweet water to the ground beneath, where it stood in little pools.

Protection for Winter.—Some rough-and-ready material is very useful for late Cauliflowers, Broccoli, roots of tender plants, and throwing over mats and frames. Nothing is better for such purposes than rough hay, and from some outlying places in the pleasure grounds we used to collect and keep some for this purpose. This season we have not saved more

than will be required for Mushroom beds. There has been so little hay in this neighbourhood that we know it will be of no use going after such material to the farm. We know that though corn crops on the whole are good, the straw is short, and it will be wanted for feeding as well as littering purposes. We have, therefore, secured ourselves, and will yet collect more as a substitute. We obtain a certain amount of stable dung, chiefly litter with some droppings. We could make little use of it in the ordinary way, as we could not command water to moisten and work it. We had it, therefore, well shaken to get droppings, &c., out of it, well dried, and built as we got it into a stack, which we shall cope with itself, and with this litter now well dried we feel we shall be tolerably independent as respects protection for the winter.

Turf Heaps.—Where the soil is not so dry as ours, now is the best time of the year for making a heap. There is no better plan than making such heaps in parallelograms of from 3½ to 4 feet in width, raising them to a height of 4 or 5 feet, and then drawing gradually in with a hipped roof in form like the letter A. We used to cover the hip with turf, the grass outside, fastened with wooden pins, to ensure dryness; but we find the outsides of the ridge soon become green, and that dryness is sufficiently secured without any such trouble. When the hip roof is formed we merely beat it on each side with a spade. These heaps nicely piled should not be wider, or the air will not play through the layers. The object of the heaps is to have the soil thoroughly sweetened without wasting or rotting the fibre.

FRUIT GARDEN.

Gathered quantities of Apricots, even when not quite ripe, to save them from wasps. The wasps are not now so troublesome, as we found and destroyed some large nests. A few cool nights would be the best relief, though other means must be tried.

General operations have been much the same as last week. On the 13th all trees fully exposed to the sun suffered much from the heat and the wind, Peach trees even hanging their leaves; and if we have not a few dull days we must try if possible to help them at the roots. This season will try a good many plans and systems. Shallow borders and bottomed with concrete, slabs of stone or tiles cemented, were all the rage at one time. It would be well to know in what kind of borders trees have stood best this season where they could not be helped with much water. We know that moisture in the form of vapour will rise through firm substances, as we have seen a good deal of moisture condensed under large bell-glasses set on a firm, dry, gravel walk, and even on exposed stone pavement. Still, we do not think that moisture in the form of vapour will rise so freely through such tiles and stone flags as through the more open general soil, and therefore some facts and observations in this respect would be valuable. Perhaps we may find in the end that a deepish loam is no bad thing if by surface mulching we can only encourage the roots to keep near the surface. They would then be more independent of moisture in dry seasons, and they would not be encouraged too deep and become too luxuriant in moist seasons. Many of our Apples are falling, and the general crop will be smaller than usual unless rains come quickly.

ORNAMENTAL DEPARTMENT.

Much the same as last week. Lawns needed nothing except a switch with the daisy knife; walks were put into good order; and potting and cutting-inserting were the chief work engaged in. The flower beds have as yet stood well.—R. F.

TRADE CATALOGUES RECEIVED.

H. Camell, Station Road, Woolwich.—*Autumn Catalogue of Fuchsias, Pelargoniums, Verbenas, &c.*
 Sutton & Sons, Reading.—*Catalogue of Bulbous Flower Roots, Plants, Seeds, &c.*
 Child & Lorimer, 49, Darley Street, Bradford, and Bradford Nurseries, Shipley.—*Catalogue of Dutch Bulbs, &c.*
 Ferdinand Gloede, Beauvais (Oise), France.—*List of New and Splendid Strawberries.*

TO CORRESPONDENTS.

** We request that no one will write privately to any of the correspondents of the "Journal of Horticulture, Cottage Gardener, and Country Gentleman." By so doing they are subjected to unjustifiable trouble and expense. All communications should therefore be addressed *solely* to *The Editors of the Journal of Horticulture, &c.*, 171, Fleet Street, London, E.C.

We also request that correspondents will not mix up on the same sheet questions relating to Gardening and those on Poultry and Bee subjects, if they expect to get them answered promptly and conveniently, but write them on separate communications. Also never to send more than two or three questions at once.

N.B.—Many questions must remain unanswered until next week.

BOOKS (H. T.).—The "Cottage Gardeners' Dictionary," which you can have free by post from our office for 7s. 2d.

NETTING FOR FRUIT TREES (J. P.).—We are sorry we cannot assist you to the address you require.

MORETON BAY CHESTNUT (Fibula).—This plant has been introduced to this country as well as some of the fruit. It is not yet common in England, and we are not aware to what extent it has been exposed to our winter climate. If it will do anywhere, the Sussex coast will be as favourable as any. We do not know where the Buaya-Buaya is to be procured.

BUDGING PEACHES (E. G.).—From now till September is a good time for budding. You must skilfully extract the wood from the Peach buds before inserting them, and you may use the double or triple buds indiscriminately.

GRAPES MILDEWED (T. V.).—Your Grapes are severely attacked by mildew, the remedy for which is flowers of sulphur dusted over all the parts affected. Keep the air of the house dry and well ventilated, and do not allow the Vine to suffer from want of water at the roots.

GRAPES NOT RIPENING (A. T.).—Your Vines are overcropped, and your border, though inside, does not keep the roots there; they have evidently got into a soil which is ungenial to them. It is a case which is not unusual.

EXHIBITING FRUIT (A Young Gardener).—1, 2, 3, 4, 6, 7, 8, and either Apricots or Plums according to their quality, the former the more valuable. Black and White Grapes, and Peaches and Nectarines, are, of course, distinct varieties, and no judge could disqualify on that account. On the contrary, to have both Black and White Grapes would enhance the merit of a collection.

THE ALMOND (A. B.).—We have little doubt that the Almond is "the parent of our present race of Peaches," but how or when the hard husk became succulent we cannot tell; not by impregnation, certainly, but in all probability it arose from certain conditions in which the original abnormal tree was placed, and then culture would probably secure and develop the new form.

SHOWING ROSES (Felix Genaro).—You must show twelve trusses of Roses, a truss being any number of blooms provided they are all grown on one stalk. You must not the several blooms together, or you will be disqualified, or ought to be.

CINERARIAS DISEASED (Oh! Subscriber).—Your Cinerarias appear to be suffering from mildew. Dust them with flowers of sulphur, and give more air.

HEATING A SMALL FORCING HOUSE (H. S.).—The proposed plan will answer if your flue is strong and covered with strong ties or flues. We would make the first half of the flue in the chamber at least brick-on-bed. It will not heat so soon, but it will retain heat. You will also need some means for ensuring a moist atmosphere. One ventilator over the doorway will not do. You will want three or four at the apex of the roof, however small the openings in winter. The aspect will also be against you unless you make your short hip longer, but for Cucumbers it may do.

TRANSPLANTING MULBERRY TREES (E. M. M.).—We would recommend you to transplant your Mulberries immediately after the fall of the leaves, or when they are being shed. As the roots from the stumps may not be very vigorous this season, and tender, try one only, and leave one for next year.

STRAWBERRIES (E. Jones).—We recommend Dr. Hogg as a first class variety, of vigorous constitution, large size, and of most excellent quality.

PLUM LEAVES INJURED—MARIE LOUISE PEAR (An Amateur).—We believe the leaves of your Plums to be in great part destroyed by some insect, the tissues seeming to be eaten up. Give them a syringing with a decoction of quassia chips, or soft soap and tobacco water. The Marie Louise Pear will not grow if grafted on the Quince. It must be double-worked on that stock—i.e., some other variety grafted on the Quince first; for instance, Benrre d'Amansis, and the Marie Louise worked on that.

HOYA CARNSOSA SEED SOWING (A Foreigner).—It is not uncommon for the plant to seed in this country, though it is rather unusual for it to do so in a greenhouse. The seed should be sown in a sandy peat soil in a pot well drained, the soil being mixed with rather small corks and silver sand, so as to keep it open. Care should be taken to just cover the seed with fine soil. Water gently, and place the pot in a bottom heat of about 75°. Keep the soil moist, but not very wet, otherwise the seeds will perish. Continue in the hotbed until the plants are potted-off and established in small pots, then remove them to a stove or warm greenhouse. The seedlings you allude to are kept for exchange and for distribution to other botanical gardens.

CONSERVATORY PLANTS INFESTED WITH RED SPIDER (T. H. T.).—As you cannot use sulphur on the hot-water pipes, we would advise you to employ one of the insect-destroying compounds you will see advertised in our columns, or you may dip or syringe the plants in a solution of 2 ozs. of soft soap in a gallon of water; but it must only be applied to plants with smooth, not hairy, leaves. A few good syringings with clear water are as good as anything for the prevention and destruction of red spider. It is not often that Foras are attacked by red spider, thrips are their great enemy. Fumigation with tobacco is the remedy.

VARIOUS (Idem).—The espalier Cherry and Pear trees which have not shown a leaf this season we fear are beyond recovery. Those which are weak, and have made but little wood, we would manure well or mulch with manure as far as the roots extend, and in spring point it in, not going so deep, however, as to injure the roots. No time should be lost in sowing Calceolaria and Primula seed to produce plants for flowering next spring. We sow Primulas in spring for autumn and winter bloom,

and in July or August for spring flowering. Calceolaria seed we think best sown in July. Pampas Grass after flowering may have the dead flower-stalks cut away, but the grass should all be left, as it serves to protect the plant. It should not be removed until the plants begin to grow again, or in April. The "Portable Orchard" appeared in Nos. 411, 412, 413, 414, 416, 417, 418, 421, 423, 425, 426, and 428.

SURPLUS FRUIT (Constant Reader).—Apply to Mrs. Webber & Co., Central Avenue, Covent Garden Market, London, W.C.

APRICOTS (Hortus Apricot).—Your trees are starved. They are either very old or in very poor soil. Manure them well in the autumn by taking away the soil in which they are now growing, and filling up the space with a mixture of good loam, lime rubbish, and well-rotted manure.

ANTS (Heron).—Mix treacle with arsenic, and spread it thinly on pieces of glass or tiles which lie near their haunts. This will soon rid you of these pests. You had better allow your Potatoes to remain in the ground and give the new crop a chance of ripening. You will be no worse off in the end than you are now, and there is no remedy for your present difficulty.

NAME OF INSECT (G. Egerton).—Your caterpillar is that of Sphinx Ligustri.

NAMES OF FRUITS (A Reader for Profit).—1, Royale Hative; 2, Standard of England; 3, Fotheringham. (C. Winn).—We cannot determine the name of your Apple.

POULTRY, BEE, AND PIGEON CHRONICLE.

POULTRY FEEDING IN FRANCE.

We have spoken previously of the large supply and excellent quality of French poultry, in order to show how valuable an article of food it supplies to our neighbours. We are now enabled to relate, from an official report, in what manner, at what cost, and with what profit poultry is fattened in France.

M. Martin, who resides near the town of Casset, is the inventor of a peculiar method of management of poultry, and has attracted so much attention to his system, that the Agricultural Society of Allier appointed a commission to visit and report upon his establishment.

The feeding-house is a large rotunda, situated in the midst of a park of ten acres in extent, and on the summit of a tolerably elevated hill. In it are three octagonal stands which turn on a vertical axis; each side of the stand has five perches, and each perch receives five birds, or two hundred in all. The fowls are divided off from each other by means of small slabs of wood placed vertically on the perch, and are secured to the latter by means of strips of hide around the feet, leaving their heads and wings at full liberty. The feeding is effected in the following manner:—The operator has a small seat, which he can shift upwards and downwards in order to reach the various cages; he takes the head of the fowl opposite to him in his left hand, and with his right places in its gullet a small tin nozzle which is attached to a flexible tube communicating with a reservoir containing the food, so that a touch of the foot on a treadle projects the desired quantity into the fowl's stomach. A graduated dial, with a hand in connection with a piston, serves to regulate the amount of food according to the age and kind of bird, and the degree to which it has been fattened. The feeding is performed with great rapidity, an hour being sufficient for two hundred birds, or one frame, and the fowls seem to enjoy it, looking sharply after any stray drops of food that may have fallen within their reach. This food consists of barley and maize meal mixed with lard, and reduced with milk to almost a liquid state. The fowls are kept scrupulously clean, the droppings falling on sloping boards behind the perches, and thence towards the centre; every morning cut straw is thrown upon it, and the whole is swept into a hole near the centre, where it is received in an iron barrow running in a channel beneath the frame. When the fowls are ready for market, they are placed in a dark but well-ventilated apartment, and left without food for twenty-four hours; they are then suspended by the feet, a cloth is passed round them to prevent movement, and a small instrument is introduced into the throat so adroitly that they are killed instantaneously. They are then plucked, washed, drawn, wrapped up in wet cloths to cause them to cool rapidly, and placed on stages that the blood may escape freely. From thirty to forty are sent to market daily.

The reports speak highly of all the arrangements made by M. Martin, which are the results of many trials, and especially those for the radical destruction of the mites which infest all fowl-houses. M. Martin patented his system in 1867. The fowls fattened under this system have obtained for M. Martin several medals, and the Commission is of opinion that they are amongst the finest sent to market. As regards the economy of

the system, the report takes for basis the cost per day of fattening six hundred pullets, aged from three to four months; those to which it has been principally applied. The duration of the fattening is eighteen days, and one man and woman do the whole work, so that the great economy of the plan is easily demonstrated. In feeding by hand, one person cannot cram more than twenty birds an hour, or thirty at most with the use of a funnel, while under the new system two hundred are fed in an hour. The bill of coats for one day is thus set forth:—

Purchase of 33 lean pullets, at an average cost of 2 <i>l.</i> each ..	66 <i>l.</i> 0 <i>s.</i>
60 kilogrammes of meal, at 2 <i>s.</i> ..	15 0
Food for 600 { 30 litres of milk, at 1 <i>s.</i> ..	4 50
2 kilogrammes of lard, 1 <i>l.</i> 6 <i>s.</i> ..	3 20
Wages of a man and woman ..	3 50
Loss at the rate of 3 pullets per 100 ..	2 0
Interest on cost of material valued at 2000 <i>l.</i> ..	0 40
Rent of building at 3 <i>s.</i> 6 <i>d.</i> per annum ..	1 0
Paid for plucking, &c., 6 <i>s.</i> per head ..	1 65
Sundry expenses ..	3 0
Total.....say	£4 0 0 100 25

This brings the cost of a fattened pullet to a trifle over 2*s.* 5*d.*, or 50 per cent. more than the price paid for it originally. But there are certain deductions to be made from the expenses incurred—sale of feathers, manure, blood, and offal, which diminish the cost of a fat pullet to little more than 2*s.* 3*d.* To form, however, an exact estimate of the cost, it is necessary to take weight into account. The ordinary pullet of Allier at the age stated weighs 950 grammes (nearly 2½ lb. avoirdupois), and, when fattened, plucked, and ready for market, 1,123 grammes. This brings the cost to 2*l.* 5*s.* 3*d.* per kilogramme, or 11*d.* per lb. M. Martin sells his fat pullets at 3*l.* 5*s.* 0*d.* Better results still are said to be obtained with the breeds peculiarly adapted to fattening, such as that of La Breasse; pullets of this race weighing 2½ lbs., and doubling in their weight during the fattening. The plan is applicable to other poultry besides pullets. Last winter Capons, Ducks, and Turkeys were fattened by the same means with success.

The Commission expresses its surprise at the results achieved, especially considering that M. Martin has inaugurated his system in a part of the country where no progress has been made in the rearing of poultry, and where the breed of fowls is not the best adapted for fattening, and it believes that the plan may be made the starting point of a radical improvement in the rearing of poultry, which hitherto has been little appreciated, except in certain districts. France exports annually eggs to the amount of 18,000,000*l.* (£720,000), and only imports one-sixth of that amount, which proves that the climate is well adapted for poultry. If establishments like M. Martin's were set up in every department of France, and every district of England, they would become perfect manufactories of poultry, for the farmers would then always have a market for their chickens, as fattened poultry always finds ready purchasers. Moreover, the produce in manure would not be unimportant, for each pullet fattened by M. Martin gives on an average 2½ lbs. of dry manure, said to be equal to the best guano of Peru. Another great point is the health of the breeders as well as of the fowls. Poultry fattened by hand is generally kept in narrow cages, often in barrels, without a proper supply of pure air; and in the midst of all the filth, the persons who feed them tie three of the unfortunate birds together by the legs, and then cram them alternately with fifteen or twenty balls of food in spite of their violent struggles; and it is surprising how the feeders themselves live in the vitiated air around them.

In M. Martin's system the fowls are always surrounded by pure air, everything is kept scrupulously clean, washed, and disinfected by means of sulphate of iron; the birds suffer in no way from the mode of feeding, and are almost invariably healthy, and the feeders have but little to do. It has been proposed to set up a model feeding establishment in the gardens of the Acclimatisation Society in the Bois de Boulogne.

There is little doubt that many supplies of food are capable of great extension, and that poultry, whether reared naturally with the aid of houses on wheels, or on Martin's system, offers to farmers and others a fair prospect of remunerative occupation. Perhaps in time we may see realised the hope of Henri de Navarre, that every peasant should have a fowl for dinner on Sundays.—(*Food Journal*.)

DURHAM COUNTY POULTRY SHOW.

The Poultry Show in connection with the Durham County Agricultural Society's Exhibition was held on the 9th inst. at Sunderland.

It was the Society's twenty-seventh meeting, but the first on which poultry was introduced. The Show was quite a success, and most of the classes were well represented. Turner's pens were used, and every care was taken of the birds by the Committee.

Of *Dorkings* and *Cochins* there was only a small entry; of *Spanish* there were nine pens, but most of them were in the moult; the prize *Brahmas* were good. There were nine pens of *Red Game* in the adult class; the first-prize *Brown Red* was a splendid bird, and in good condition; the *Black Red* second-prize bird was also very good, but a little out of condition. There were ten pens of *Spangled Hamburgs*, some of them of great merit; the same may be said of the *Pencilled Hamburgs*. The *Polands* mustered nine pens, but many of them were not so good as we should have liked to have seen. There were eleven pens of *Red Game* chickens, some of them very promising, but a little too young for the exhibition pen. Of *Hamburg* chickens there were eleven pens, and in the "Any other variety" class eighteen pens, some of them of first-rate character. The cup for the best pen went to an excellent pen of *Brahma* chickens in this class. There were eighteen pens of adult *Red Game Bantams*, and twenty-one pens of chickens. The cup was awarded to a very good pen in this class.

DORKINGS (Any variety).—1, J. White, Warlaby, Northalerton (Grey) **COCHINS** (Any variety).—1 and 2, G. H. Proctor, Durham (Buff and White). **SPANISH** (Any variety).—1, G. Holmes, Great Driffield. 2, W. Elliott, Bishop Auckland. *hc*, W. Bearpark. **BRAHMAS** (Any variety).—1, E. Leech, Rochdale. 2, J. Stalker, West Sleaford. *hc*, G. Todd, Bishopwearmouth. **GAME**.—*Black-breasted or other Reds*.—1, T. Robinson, Bishop Auckland. 2, J. Brough, Carlisle. *hc*, W. Rodgers, Bishopwearmouth. **BULLOCKS & WILLS**.—1, W. Stone, Any other Variety. —1 and 2, J. Robinson (Duckwings). **CHICKENS**.—1, J. Dixon, 2, J. Hardy. *hc*, T. Dent, Sunderland; W. Bearpark, Anderby Steeple. **HAMBURGERS**.—*Gold and Silver-spangled*.—1, H. Pickles, jun., Earby, Skipton. 2, W. Bearpark, Anderby Steeple. *hc*, H. Pickles, jun.; W. Whitfield, Hutton Station; G. Holmes, Great Driffield. *Gold and Silver-pencilled*.—1 and 2, H. Pickles, jun. *hc*, W. Hall; W. Bearpark. **CHICKENS** (Any variety).—1 and 2, H. Pickles, jun. *hc*, C. Armstrong, Bedlington (Silver-pencilled). J. Brown & Co., Water Works (Silver-pencilled). **EGGS** (Any variety).—1, J. Brown. 2, H. Pickles. **ANY OTHER VARIETY**.—1, R. Loft, Woodinsey (Sultans). 2, E. Hawkins, Seaham (Malays). **CHICKENS**.—Cup, E. Leech. 2, H. Pickles, jun. (Polands). *hc*, J. J. Waller, Kendal (Coloured Dorkings); T. W. L. Hind, Kendal (Dorkings); J. White, Warlaby (Grey Dorkings); G. H. Proctor (White Cochins). *c*, W. Bearpark; E. Brown (Spanish). **GUINEA FOWL** (Any variety).—1, G. Todd. 2, J. S. Chaloner, Benwell Lodge. *hc*, H. Forest, Durham; T. C. Harrison, Hull. **TURKEYS**.—1, E. Leech. **DUCKS**.—1, W. Stone, Whiteby. 2, E. Leech. *Any other Variety*.—1, E. Leech. 2, Rev. J. G. Milner, Bellerby (Rouen). *c*, Rev. J. G. Milner (Rouen Duckings); T. C. Harrison. **SELLING CLASS**.—1, G. Todd (Partridge Cochins). 2, G. H. Proctor (Buff Cochins). **BANTAMS**.—*Game* (Black-breasted and other Reds).—1, D. Hunter, Nile Street (Black Reds). 2, W. Grey, Tow Law (Black Reds). *hc*, W. Rodgers (Brown Reds); T. Wigham, Sunderland (Black Reds). **CHICKENS**.—Cup, T. Clark (Black Reds). 2, Hunter. *hc*, F. Steel, Halifax (Brown Reds); T. Clark (Black Reds). *Any other Variety*.—1, J. F. Fry (Duckwings). 2, J. Hurrell (Duckwings). *hc*, Bullass & Williamson (Lemon Piles). *Any other variety*.—1, S. & R. Ashton, Mottram (Black). 2, E. Youll (Black Rose-combs). *hc*, W. Dixon, Bishopwearmouth (Black Rose-combs). **CHICKENS**.—1, S. & R. Ashton (Black Rose-combs). 2, T. C. Harrison, Hull.

Mr. James Dixon, of Bradford, was the Judge.

LISKEARD POULTRY SHOW.

The second annual Poultry Show held at Liskeard on the 4th inst. was a great success, the entries having been three times as many as last year's, and some of the birds, especially in the *Dorking* and *Game* classes, being of high merit. The cup given for the best pen of *Game* was won by Mr. J. H. Reynolds, of Redruth, closely pressed by Mr. J. Jeken. A noted local breeder of *Game* fowl exhibited some fine birds in each of the *Game* classes, notably some *Henny* and *Tassel* chickens, said to be the purest strains of those scarce breeds, but being on the Committee he withdrew them from competition. Exhibitors visiting the Show were pleased with the care and attention given the birds by the Committee.

GAME.—*Black-breasted and other Reds*.—1 and Cup, J. H. Reynolds, Red rath. 2, J. Jeken. 3, J. Beard, St. Blazey. *Duckings and other Greys and Blues*.—1, J. Hancock, Liskeard (Silver-Grey). 2, J. H. Reynolds (Black). 3, Withheld. *Tassels, Hennes, and any White-legged Variety*.—1, W. Kenrick, Menheniott (Tassels). 2, G. Martin, Devonport. Extra 2, J. H. Reynolds (Hennes). 3, H. Roberts, St. Cleer (Hennes). **MALAYS**.—1, J. Toll, Menheniott. 2, C. White, Liskeard. 3, J. Bone, Liskeard. **DORKINGS**.—1 and 2, E. Burton. **SPANISH**.—1, S. R. Harris, St. Day. 2, Mrs. Smith. 3, J. H. Nickolls. **COCHINS**.—1, W. Humphreys, Liskeard. 2, J. Long, Plymouth. 3, F. Brewer, Lostwithiel. **BRAHMAS**.—1, Mrs. Smith. 2, J. Beard. 3, J. H. Nickolls. **POLANDS**.—1 and 2, J. Beard. 3, Miss Webber, Exeter. **HAMBURGERS**.—*Pencilled*.—1 and 2, S. R. Harris. 3, R. Courtney, Liskeard. *Spangled*.—1 and 2, S. R. Harris. 3, J. Roberts, Menheniott. **BANTAMS**.—1, C. White. 2, Miss Webber. 3, S. R. Harris. **ANY OTHER VARIETY**.—1, J. Nickolls (Black Hamburgs). 2, S. R. Harris (Minorca). 3, F. Brewer (Minorca). **SELLING CLASS**.—1, J. J. Waller. 2, Truro (Golden-pencilled Hamburgs). 3, W. Tolland, Liskeard (Crested Polands). 3, J. Hancock (Game Hennes). **DUCKS**.—1, J. E. Hawken, Lostwithiel (Aylesburies). 2, E. Burton (Rouen). Extra 2, Miss Webber (Mandarin). 3, S. R. Harris. **GESE**.—1, T. Burrows, St. Cleer. 2, S. Bone, Liskeard. **TURKEYS**.—1, Mrs. Smith. 2, Withheld.

PIGEONS.—*Carriers*.—1, E. Burton. 2, J. S. Richards, Truro. *Tumbler*.—1, E. Burton. 2, A. Bailey, Liskeard. *Jacobins*.—1, W. C. Herring, Menheniott. 2, Mrs. Lander, Menheniott. *Fantails*.—1, S. Richards. 2, J. Oliver, Liskeard. *Common*.—1, E. Burton. 2, S. Richards.

Mr. Leeworthy, of Barnstaple, was the Judge.

BLACKPOOL POULTRY SHOW.

The following awards were made at this Show, held on the 10th and 11th inst.

DORKINGS.—*Grey*.—1, T. Briden. 2, J. Robinson. *White*.—1 and 2, J. Robinson. *Cock*.—1, J. Robinson. **BRAHMAS**.—1, J. H. Pickles. 2, J. Watts, Spanish. —1, C. W. Brierley. 2, H. Beldon, Bingley. **GAME**.—1 and 2, C. W. Brierley

Middleton. *Cock*.—1 and 2, C. W. Brierley. *COCHINS*.—1, T. Stretch. 2, H. Green. *HAMBURGS*.—*Golden-pencilled*.—1, H. Beldou. 2, B. Bee. *Silver-pencilled*.—1, J. Robinson. 2, H. Beldou. *Golden-spangled*.—1, J. Robinson. 2, H. Beldou. *Silver-spangled*.—1, G. & J. Duckworth. 2, H. Beldou. *Black*.—1, C. Sidgwick, Keighley. 2, H. Beldou. *BANTAMS*.—1, J. Watts. 2, G. Anderson. *CREVE-CŒUR*.—1, H. Beldou. 2, E. Cross. *HORDANS*.—1, H. Beldou. 2, J. Robinson. *ANY OTHER VARIETY*.—1, J. Watts. 2, H. Beldou. *GEESE*.—1, M. Seamons, Aylesbury. 2, S. H. Stott. *DUCKS*.—*Aylesbury*.—1, M. Seamons. 2, J. Robinson. *Ducklings*.—1, E. Leech, Rochdale. 2, M. Seamons. *Rouen*.—1, T. Wakefield. 2, J. J. Waller. *Ducklings*.—1, J. J. Waller. 2, T. Wakefield. *Black*.—1, S. Burn. 2, J. Robinson. *Any other Variety*.—1, H. B. Smith. 2, S. H. Stott. *Ducklings*.—1, C. W. Brierley. 2, S. Burn. *TURKEYS*.—1 and 2, E. Leech.

CHICKENS.

DORRING.—*Grey*.—1, T. Briden. 2, J. Watts. *White*.—1 and 2, J. Robinson. *GAME*.—1, C. W. Brierley. 2, T. Wareing. *COCHINS*.—1 and 2, C. Sidgwick. *HAMBURGS*.—*Golden-pencilled*.—1, H. Beldou. 2, B. Bee. *Silver-pencilled*.—1, H. Beldou. 2, J. Robinson. *Golden-spangled*.—1 and 2, E. Brierley. *Silver-spangled*.—1, G. & J. Duckworth. 2, H. Beldou. *BANTAMS*.—1, H. Beldou. 2, B. Bee. *GEESE*.—1, E. Leech. 2, W. Brierley.

WHITBY POULTRY SHOW.

The following are the awards at this Show, held on the 11th inst.:

DORRING.—1, J. White, Warley. 2, G. Holmes, Driffield. *CHICKENS*.—1, J. White. 2, W. English, Pickering. *SPANISH*.—1, G. Holmes. 2, W. Elliott, Bishop Auckland. *CHICKENS*.—1, H. Beldou. 2, J. B. Stephenson. *GAME*.—*Black-breasted or other Reds*.—1, H. M. Julian, Hull. 2, T. Robson, Bishop Auckland. *Any other Variety*.—1, H. M. Julian. 2, J. Robson. *Duckworth*. *CHICKENS*.—1, T. Blackburn, jun., Broughton. 2, W. Sleightholm, Uxbridge. *COCHINS*.—1, J. Sichel, Chester. 2, J. Booth, Lythe. *C. G. Speedy*. *Whitby*. *CHICKENS*.—1, J. Dove, Northampton. 2, T. H. Readman, *hc*, G. Holmes, *c*, W. G. Purdon, Driffield. *BRAHMA POOTRA*.—1, E. Leech, Rochdale. 2, W. Whiteley, *hc*, E. Corney, Whitby; H. Beldou; W. Newton, Whitby. *CHICKENS*.—1, E. Leech. 2, J. Sichel, *hc*, W. Stonehouse. *FRENCH*.—1, H. Beldou. 2, J. J. Maillen (Creve-Cœur). *hc*, W. G. Purdon. *c*, T. Previval (Creve-Cœur). *HAMBURGS*.—*Golden-spangled*.—1, H. Beldou. 2, G. Holmes, *hc*, H. Pickles, jun., Enby; G. Garbutt, Sainsbury. *Silver-spangled*.—1, H. Pickles, jun. 2, H. Beldou. *hc*, G. Holmes. *Gold or Silver-spangled*.—1, H. Beldou. 2, H. Pickles, jun. *hc*, G. Holmes. *Gold or Silver-pencilled*.—1, G. Holmes. 2, H. Pickles, jun. *hc*, G. Holmes. *Gold or Silver-pencilled*.—1, H. Pickles, jun. 2, Rev. R. A. White, *hc*, J. Webster, *c*, H. Beldou. *Silver*. *GAME BANTAM*.—1, G. Holmes. 2, T. Blackburn, jun. 3, W. F. Edwistle, Cleckheaton. *BANTAM* (Any other variety).—1, H. Beldou. 2, T. Tinley, Whitby. *ANY OTHER VARIETY*.—1 and 2, H. Beldou. *Black*.—1, E. Leech. 2, T. Readman (Silver-pencilled). *Welburn (Java Fowls)*.—H. Pickles (Silver Polard). *DUCKS*.—*Black East Indian*.—1 and 2, S. Burn. *Aylesbury*.—1 and *hc*, W. Stonehouse. 2, E. Leech. *c*, J. Dove. *Rouen*.—1, G. Garbutt. 2, E. Leech. *Any other Variety*.—1, S. Burn (Maudarins). 2, W. English. *GEESE*.—1, E. Leech. 2, Rev. G. Huxter, Stillingfleet. *hc*, J. Wilkinson. *GOSSINGS*.—1, G. R. Young. 2, J. Wilkinson. *hc*, G. Richardson, Uggelbarby. *TURKEY*.—1, E. Leech. 2, Rev. G. Huxter. *hc*, G. R. Young. *White*.—1 and *hc*, Mrs. Ward, Barningham. 2, E. Leech. *Black*.—1 and 2, W. English. *hc*, W. Dickinson, Lythe (Creve-Cœur); W. English, *c*, C. Banberry.

DISTRICT PRIZES.

DORRING, *SPANISH*, *COCHIN*, *BRAHMA*, or *CREVE-CŒUR*.—*Chickens*.—Cup, T. H. Readman (Cochin). *hc*, E. Corney (Brahma). *c*, W. Stonehouse (Brahma). *ANY OTHER VARIETY*.—Cup, J. Webster (Golden-pencilled Hamburgs). *hc*, C. Clarkson (Gambus). *c*, T. H. Readman (Silver-pencilled). *Black*.—1, E. Leech. 2, W. English. *hc*, W. Dickinson (Aylesbury). *c*, J. Wilkinson (Geese).

PIGEONS.

POSTER.—1, E. Horner, Harewood. 2, J. Hawley, Bingley. *TUMBLER*.—1, E. Horner. 2, J. Garbutt, Farnley. *CARRIERS*.—1, E. Horner. 2, W. Canby, Beverley. *hc*, W. Taylor, Stanhope Mill; J. F. White, Birmingham. *FANTAIL*.—1, J. F. Lovelock. 2, E. Horner, Jacobin.—1 and 2, E. Horner. *hc*, R. Wilson. *TRUMPETER*.—1, E. Horner. 2, R. Wilson. *BARB*.—1 and 2, E. Horner. *hc*, H. Yardley. *ANY OTHER VARIETY*.—1, H. Yardley. 2, E. Horner. *hc*, Dr. Alexander, Castleton (Owls). *SELLING CLASS*.—1 and 2, E. Horner. *c*, J. Candale.

JUDGES.—Mr. James Dixon, Bradford; Mr. Harry Adams, Beverley.

STROUD POULTRY SHOW.

The meeting on the 10th, 11th, and 12th inst., was the first of the kind ever held in Stroud, and under the management of a most energetic Committee it was certainly one of the best first shows we ever met with. Saving a slight mistake in the classification of the Hamburgs in the prize schedule, the arrangements were as faultless as could have emanated from the most practised managers. The tent was as spacious and well ventilated; the pens the well-known ones of Mr. Billott, of Southampton; and in the matter of feeding, if error existed it was rather on the side of over-attention than of neglect. All this, coupled with the finest weather, brought together a host of visitors, and the success of the Show must have been very great.

Grey *Dorings* were especially good classes, but, as might be anticipated, mostly much out of condition. *Spanish* were in strong force, some of the best birds in the kingdom competing; and it is worthy of especial note Mr. E. Jones's cup pen was, even this late in the season, in point of condition equal to birds of early spring time. A remarkably good collection of *Cochins* was on view, and the good quality of the *Game* classes is equally worthy of record. Of *Hamburgs* the Spangled varieties took precedence in all cases, as by an oversight in the prize list they had to compete with the Pencilled breeds, the latter, as will be expected, showing just now in very faded feather. The *Game Bantam* class was perhaps the worst represented of any. *Aylesbury Ducks* were faultless, and in this class, as in *Geese*, Mr. Fowler, of Aylesbury, held undisputed sway. This gentleman's wonderfully well-shown pen of *Geese* took the victuallers' silver cup, being the prize of highest value in the schedule for the best pen of any variety of poultry exhibited. In the "Variety" Duck class *Buenos Ayrean*, shown by Mr. Saunders Sainsbury, took the first prize, and a pen of good *Carolina* the second position.

The *Pigeons* were well worthy of a close inspection. Carriers throughout were extraordinary, though many pens were badly matched

—viz., a really unexceptionable and a middling bird together. *Pouters* were as good as can be generally met with at our best shows, and to a remarkably good *Blue* pair of this variety the Pigeon silver cup was awarded.

DORRINGS (Any variety).—1 and Cup, J. Martin, Worcester. 2, F. Parlett, Great Baddow. 3 and *c*, L. Patten. *hc*, Rev. A. Kingscote; J. Lewry, Bolney Cockfield; M. Putney, Dorking; Hon. H. Fitzwilliam. *BRAHMS*.—*Dark*.—1 and Cup, G. F. Whitehouse, Birmingham. 2, Hon. Miss Douglas Pennant, Penryn Castle, Bangor. 3, J. Stalker. *c*, J. Sichel, Timperley; W. A. Taylor, Ham-chester; H. Lingwood, Gresting. *Light*.—1, H. Dowsett. 2 and 3, J. Parra, Postford. *COCHINS*.—*Cinnamon and Buff*.—1, 2, and Cup, J. Cattell, Birmingham. 3, W. P. Rylauds. *hc*, W. A. Taylor. *c*, Mrs. Allsopp, Hindlip Hall. *Brown or Partridge*.—1, E. Tudman, Whitechurch. 2, J. K. Fowler, Aylesbury. 3, W. A. Taylor. *hc*, J. Stephens, Walsall. *SPANISH*.—1 and Cup, E. Jones, Clifton, Bristol. 2, F. C. Nicholas. 3, T. Barmfield, Clifton. *hc*.—Barry, Totterdown; G. Tonkin, Bristol;—Allsopp. *c*, Hon. Miss Douglas Pennant; R. Barrett, Siond. *GAME*.—*Black-breasted and other Reds*.—1 and Cup, Duke of Sutherland, Trentham. 2, J. Laming, Spalding. 3, S. Mathew, Stowmarket. *hc*, K. Scriminger, Paulton, Lutterworth. *c*, G. Thomas. *Duckwings and other Greys and Blues*.—1, H. M. Julian, Hull. 2 and 3, S. Mathew, Suffolk. *hc*, J. Laming. *c*, G. S. Crawley, Crawley Moorfield. *HAMBURGS*.—*Silver-pencilled or Spangled*.—1 and Cup, H. Beldou, Bingley. 2, 3, Duke of Sutherland. *Golden-pencilled or Spangled*.—1 and *c*, Duke of Sutherland. 2, J. Newton, Silsden, Leeds. 3, C. Bloodworth. *hc*, Miss C. E. Palmer. *ROSS*.—1, J. Hinton, Warmminster. 2, H. Beldou. 3, Miss E. Webber, Exeter. *FRENCH FOWLS*.—1, H. Wyndham. 2, Hon. C. Fitzwilliam, Wentworth Woodhouse. 3, Mrs. Smith. *hc*, J. K. Fowler; Mrs. J. Pattison. *ANY VARIETY*.—1, Duke of Sutherland. 2, J. Sichel. 3, Mrs. Burrell, Ipswich. *hc*, F. Brewer. *c*, F. Wilton; J. Hinton; Mason & Walker, Denton. *GAME BANTAMS* (Any variety).—1, T. Dyson, Halifax. 2, J. Norris, Callowell, Stroud. 3, E. S. Cornwall, Wotton-under-Edge. *c*, Miss M. Webber, Exeter. *BANTAM* (Any other variety).—1, J. Sichel, Easton, Maresfield. 2, G. Cooper, Ampney Crucis. 3, W. Marland. *SINGLE COCKS*.—1, J. Martin. 2, H. Stephens. 3, J. H. Dawes, *hc*, G. Dingley. *c*, E. Brown; G. Tonkin; J. Laming, Spalding (2); J. Bloodworth; Duke of Sutherland; H. Yardley, Birmingham. *DUCKS*.—*Aylesbury*.—1 and 2, J. K. Fowler. *hc*, Mrs. Burrell. *c*, J. W. Webb, Stroud; D. Lae. *Rouen*.—1 and 2, W. Stephens. *hc*, G. Hanks; J. K. Fowler; J. Maggs, Tetbury. *Any other Variety*.—1 and *c*, G. S. Sainsbury, Devizes. 2, G. S. Crawley, Gresting (Any variety).—1 and Cup, J. K. Fowler. 2, G. H. Jones, J. Parra. 3, G. S. Crawley (Any variety).—1, Rev. N. J. Radley, Hollington House, Newbury. 2, Miss Godsell.

PIGEONS.

CARRIERS (Any variety).—1, H. Yardley. 2, R. Filton. *hc*, R. Filton; J. C. Ord. *c*, H. Yardley; J. F. White, Birmingham. *POUTERS*.—1, 2, *hc*, and Cup, R. Filton, Deptford. *c*, H. Yardley. *TUMBLERS*.—*Almond*.—1 and *hc*, R. Filton. 2, P. H. Jones, Fulham. *Any variety except Almonds*.—1, 2, and *hc*, E. Strickley. *c*, S. A. Wyllie, East, Maresfield. *English*.—1, P. H. Jones. 2, H. Yardley. *hc*, S. A. Wyllie. *FANTAILS*.—1, H. Yardley. 2, J. Walker. *hc*, J. Walker; J. Milward. *c*, P. H. Jones. *ANY OTHER VARIETY*.—1, R. Filton. 2, S. A. Wyllie. *hc*, S. A. Wyllie; P. H. Jones; F. G. Phillips; G. Gregory. *c*, H. Yardley (2); C. Stephens, Eley; E. T. Dew, Weston-super-Mare; S. A. Wyllie; T. A. Dean (2); W. Stephens.

The Judges for poultry were the Rev. G. Hodson, of North Petheron, and Mr. Edward Hewitt, of Birmingham; and the Judge for Pigeons, Mr. Tegetmeier, of London.

THE HONEY SEASON, &c.

Your correspondent, "UTENHAEG," would be pleased to know the average of my hives, "all told." I can only tell him that I have in my home apiary fourteen stocks of Ligurians, and in another apiary, about two miles distant, I have eighteen other stocks; all with the exception of three, are in frame hives. The latter apiary consists principally of black or English bees. The bees in each apiary have been pretty freely experimented upon, for the purpose of making notes on or to refute certain statements lately put forth, the result of which will appear in another bee book at no distant period; and there is no question but this has been one of the most favourable seasons for my purpose. I have raised queens from Ligurian brood comb in eleven days, and worker brood has come forth in nineteen days from the eggs being deposited in the cells, and to-day I have examined a stock which has been thirteen days raising a queen. I saw her this morning running wildly over the cells; she was rather small, but well marked, and I shall anxiously watch her leaving the hive for her wedding trip, as I have done that of several other Ligurian queens which I have reared this season, and probably I may report the result.

It may be of interest to some of your readers to know that on May 21st I received a swarm of Ligurians, imported from their native Alps, which I at once transferred into a thirteen-frame hive. This swarm went to work in good earnest, and on July 11th had so far filled the whole of the frames as to induce me to form from it two artificial swarms. I did it thus—viz., I took four of the combs, which I put into a ten-frame hive, five of the combs (with the bees of course) I put into another hive of the same kind, and left the queen (I think one of the largest and finest queens I ever saw) "at home" with the four combs remaining, and on the 22nd of July each division or artificial colony had raised for itself a beautiful queen, which I have since found on examination to have proved fertile.

I cannot now give the average produce of my hives "all told," good and bad, having never weighed any, except the particular hive referred to in my previous communication, for I have found that experiments on my Ligurians in my home apiary have occupied so much of my time, that I have been

compelled to let my black bees take their chance until the end of September, at which time I hope to exchange the queens for pure imported Italians to reign in their stead.

I shall be interested to see the account of all "UITENHAGE'S" hives, good and bad, and I may state that most of the outside combs which I have taken already will bear comparison with those usually taken from "supers."

In reference to the Rev. G. Raynor's communication, I may just remark that I much question whether the queen is ever impregnated inside the hive, as my experience teaches me that impregnation always takes place outside the hive and "on the wing;" and I am also of opinion that the queen is generally impregnated prior to her leaving the hive with a swarm, in which case her progeny would not be affected by her being placed amongst an apiary of black bees.—SUDBURY.

[It is only first swarms that can be expected to remain pure, as these are usually, although not always, accompanied by the old queen. After-swarms have only virgin queens.]

COLONEL F. C. HASSARD, R.E.—The lovers of poultry will learn with regret that this gentleman has been ordered home, and will soon have reached England. Few who had any acquaintance with the Colonel will deny that to his individual efforts during his stay in Canada, especially in Toronto, is owing much of the improvement in the culture of pure-bred poultry which has recently become so visible in this country. As a poultry and Pigeon fancier he had in Canada no equal, while to his thorough acquaintance with the rules of English poultry clubs, and his superior knowledge of poultry, much of the recent improvement in poultry judging at our shows is to be attributed. With him originated the inception of a poultry club in Ontario. He communicated his views on the subject to a few fanciers, who sided him in the formation of a society, the benefits of which to poultry-breeders is a recognised fact.—(*Canadian Poultry Chronicle*.)

THE VINEGAR PLANT.

In answer to inquiries as to where this strange production may be purchased or procured, I may state that it is never offered for sale, but may be easily obtained by the following means. Leave a little vinegar in a small bottle to become stale (during hot close weather is best), till a film appears on the surface. This film is the spawn or mycelium of a species of mildew, and is the incipient state of the Vinegar Plant proper. If a few fragments of coarse brown sugar be now added it will somewhat aid its growth; but when the film has attained the thickness of parchment it is ready for transfer to syrup, where it soon becomes the housewife's normal Vinegar Plant.

Procure a large jar or bottle, and to two quarts of boiling water add half a pound of treacle and half a pound of the commonest brown sugar; stir well together, and when cool transfer the film from the surface of the vinegar to the surface of the syrup; cover up to exclude air, and keep in a warm cupboard. This film will now rapidly grow and form a thick, slippery, gelatinous mass all over the surface of the syrup, and in the course of six weeks or so the liquid will be changed to excellent vinegar. The Vinegar Plant can now be taken and divided into layers, or cut up into fragments, each piece of which, if placed upon fresh syrup, will rapidly grow and change the liquor into vinegar. The vinegar should be allowed to settle, and be strained before it is used.—W. G. S.

OUR LETTER BOX.

BOOKS (*John Chose*).—The "Poultry-Keeper's Manual," published at our office, is the best book on the subject, and can be forwarded free by post for 7s. 1 d. (*G. Lee*).—"My Bee Book," by the Rev. W. C. Cotton, is an interesting and instructive work, but the fact of its having been written nearly thirty years ago is sufficient to prove that it is not suited to the instruction of even a novice in the modern system of scientific bee-keeping.

CANKER IN PIGEONS (*Nonplussed*).—Diseases of the throat have this dry weather been wonderfully common, both with the human subject and with Pigeons, as if the very intense and lengthened dryness of the atmosphere acted as the reverse so frequently does. Try a strong solution of alum, applied with a feather twice a-day. Thirty years' experience in Pigeon-keeping convinces us that these birds will bear almost any amount of heat in their loft, but cannot bear any draught. Vary their food, giving peas now for a time.

ROUP IN PIGEONS (*W. M.*).—See what we have said above concerning heat and cold for Pigeons. Perhaps you ventilate overmuch, in other words, put the birds at night in a constant draught. Try a dose or two of charcoal powder, or a dose of carbonate of soda, or a pinch of alum; all these have been known to cure roup.

PIGEONS NOT BREEDING (*J. N. E.*).—Baldpated Trunblers are such ex-

cellent breeders, that, supposing your birds are of the opposite sexes, we can conceive no reason for their barrenness, except old age.

HIVING A SWARM OF BEES SETTLED IN A ROOF (*J. M.*).—You require skilled assistance to enable you to secure the swarm, which can only be done by opening the roof, and thus obtaining access to the space occupied by the bees.

BEE HIVES AT LISKEARD POULTRY SHOW.—Mr. W. J. Pettitt, of Dover, was awarded the silver medal for the best bee hive for cottagers' use at this show.

FRAME HIVES (*James Hall, Kedington*).—We have no knowledge of the hive to which you refer beyond what we can glean from the handbill, but we may confess to not being very favourably impressed with it. If you wish for a moveable comb hive we should recommend the one named after Mr. Woodbury.

OAK SILKWORM (—).—The following reply is from Dr. Wallace, of Colchester:—"The culture of the Yama Mai (Japan Oak) Silkworm in this country is not yet successfully introduced. Many have failed in Great Britain and Europe; nevertheless, there are several exceptions. In 1869, a German Baron obtained 37,000 cocoons, and others have likewise succeeded in various parts of the Continent. In England several gentlemen have reared this insect, more especially in the western and midland districts; but in the southern and eastern districts nearly all attempts have failed. I believe the cause of failure to be the exposure of the caterpillar to too dry an atmosphere. In a cool moist climate success has been obtained. I know of at least one hundred cocoons this year raised by three individuals. Correspondents in Japan have promised to send me full details of the mode they practised of rearing this valuable insect, and also some particulars of the climatal influences. Bombyx Mori culture on light soils and in such seasons as the present is highly successful in our southern and eastern districts."

METEOROLOGICAL OBSERVATIONS

in the Suburbs of London for the week ending August 16th.

DATE.	BAROMETER.		THERMOMETER.				Wind.	Rain.
	Max.	Min.	Air.		Earth.			
			Max.	Min.	1 ft.	2 ft.		
Wed. . . 10	30.71	29.976	75	52	67	62	N.	.16
Thurs. . 11	30.099	30.084	78	50	73	62	N.E.	.00
Fri. . . 12	30.159	30.166	82	56	68	62	N.E.	.00
Sat. . . 13	30.182	30.162	79	52	70	63	E.	.00
Sun. . . 14	30.189	30.050	73	59	66	63	E.	.00
Mon. . . 15	29.987	29.911	70	43	69	62	E.	.00
Tues. . 16	30.012	29.995	75	42	63	61	N.E.	.00
Mean. .	30.099	30.031	76.14	50.57	68.00	62.14	..	0.16

- 10.—Fine, cloudy; showery; clear and very fine.
- 11.—Cloudy but fine; cloudy; very fine, clear.
- 12.—Very fine; exceedingly fine; clear and fine.
- 13.—Overcast; very fine; cloudy but fine.
- 14.—Fine; overcast; densely overcast.
- 15.—Densely overcast; clear and fine at night.
- 16.—Densely overcast; fine; clear at night.

COVENT GARDEN MARKET.—AUGUST 17.

THE markets have been less active during the week, and the demand in the provinces has also slackened as they become supplied from their own localities, so that a reduction in prices has taken place. Hothouse produce is more than sufficient for the trade. Peaches and Nectarines of good quality are being offered from the open walls, and range from 3s. to 6s. per dozen. Plums of all descriptions are very abundant. In the Potato trade in all its branches a fair amount of business is done.

FRUIT.

	s.	d.	s.	d.		s.	d.	s.	d.
Apples.....	1	0	2	0	Mulberries.....	Rs.	0	9	0
Apricots.....	doz.	1	0	3	Nectarines.....	doz.	3	0	10
Cherries.....	lb.	0	6	1	Oranges.....	100	0	14	0
Chestnuts.....	bushel	0	0	0	Peaches.....	doz.	5	0	12
Currants.....	1/2 sieve	2	0	4	Pears, kitchen.....	doz.	0	0	0
Black.....	doz.	3	0	5	dessert.....	doz.	1	0	3
Flora.....	doz.	3	0	6	Pine Apples.....	lb.	2	6	5
Filberts.....	lb.	0	1	0	Plums.....	1/2 sieve	2	0	5
Cobs.....	lb.	0	2	1	Quinces.....	doz.	0	0	0
Gooseberries.....	quart	0	0	0	Rasberries.....	lb.	0	6	1
Grapes, Hothouse.....	lb.	2	0	6	Strawberries.....	lb.	0	0	0
Lemons.....	1/2 100	8	0	14	Walnuts.....	bushel	10	0	16
Melons.....	each	1	0	4	do.....	100	1	0	2

VEGETABLES.

	s.	d.	s.	d.		s.	d.	s.	d.
Artichokes.....	doz.	3	0	6	Leeks.....	bunch	0	4	0
Asparagus.....	1/2 100	0	0	9	Lettuce.....	doz.	1	6	3
Carrots, Kidney.....	1/2 sieve	0	6	0	Mushrooms.....	potte	3	0	4
Broad.....	bushel	0	0	0	Mustard & Cress.....	punnet	0	2	0
Beet, Red.....	doz.	2	0	3	Onions.....	bushel	4	0	6
Broccoli.....	bundle	0	0	0	pickling.....	quart	0	4	8
Brussels Sprouts.....	1/2 sieve	0	0	0	Parsley.....	ieve	3	0	0
Cabbage.....	doz.	1	0	2	Parsnips.....	doz.	0	9	1
Capsicums.....	1/2 100	0	0	0	Peas.....	quart	1	0	6
Carrots.....	bunch	0	4	8	Potatoes.....	bushel	3	6	5
Cauldflower.....	doz.	2	0	6	King.....	doz.	1	0	6
Celery.....	bundle	1	6	2	Radishes.....	doz. bunches	0	0	0
Coleworts.....	doz. bunches	3	0	6	Rhubarb.....	bundle	0	0	0
Cucumbers.....	each	0	6	1	Savoy.....	doz.	0	0	8
pickling.....	doz.	2	0	4	Sea-kale.....	basket	0	0	0
Endive.....	doz.	2	0	0	Shallots.....	lb.	0	6	0
Fennel.....	bunch	0	3	0	Spinach.....	bushel	3	0	0
Garbs.....	lb.	0	8	0	Tomatoes.....	doz.	1	0	6
Herbs.....	bunch	0	3	0	Turnips.....	bunch	0	6	8
Horseradish.....	bundle	3	0	5	Vegetable Marrows.....	doz.	2	0	3

WEEKLY CALENDAR.

Day of Month	Day of Week.	AUGUST 25-31, 1870.	Average Temperature near London.			Rain in last 43 years.		Sun Rises.		Sun Sets.		Moon Rises.		Moon Sets.		Moon's Age.	Clock before Sun.		Day of Year.			
			Day.	Night.	Mean.	Days.	m.	h.	m.	h.	m.	h.	m.	h.	Days.	m.	s.					
25	Th	Newcastle-under-Lyme Horticultural Show.	74.1	49.7	61.9	16	2	af	5	1	af	7	50	af	2	41	af	6	28	1	57	237
26	F		72.5	48.4	60.1	15	3	5	59	6	5	4	12	7				●	1	40	238	
27	S		73.3	49.1	61.2	12	5	5	57	6	24	5	39	7				1	1	23	239	
28	SUN	11 SUNDAY AFTER TRINITY.	72.7	49.7	61.2	19	7	5	55	6	46	6	3	8				2	1	6	240	
29	M		71.2	47.6	59.4	16	8	5	53	6	7	8	25	8				3	0	49	241	
30	Tu	Banbury and Daventry Horticultural Shows.	74.5	48.2	61.3	11	11	5	51	6	39	9	49	8				4	0	31	242	
31	W	Glamorganshire Horticultural Show.	71.5	47.4	59.4	17	12	5	49	6	51	10	13	9				5	0	12	243	

From observations taken near London during the last forty-three years, the average day temperature of the week is 72.8°, and its night temperature 48.6°. The greatest heat was 89°, on the 25th, 1859; and the lowest cold 31°, on the 9th, 1861. The greatest fall of rain was 1.92 inch.

AMONGST MR. LAXTON'S PEAS.



FROM London the Great Northern Railway takes us to Stamford, or ought to have done so if the great lord of Burghley had not willed it otherwise. Now it leaves us at Essendine, a few miles distant, and from thence we are the passengers of the Most Noble the Marquis of Exeter. Stamford was a busy place in the old coaching days, and is now a very interesting one, celebrated for its churches and bells. Stamford might have been what

Peterborough now is—a brisk and busy centre of railway communication, had not the lord of the soil prevented the passing of the great railway near his portals. As it is, Stamford stands still; Stamford wants brushing up. It was not, however, to see the town that I went there, but the greatest man in Stamford, horticulturally speaking—Mr. Laxton, well known as a great horticulturist, as a successful introducer of new Peas—Peas, too, of a most wonderful character.

What an advance amongst our Peas during the last ten or twelve years! Our Pea lists, no doubt, are too long already, and if we are to believe all that is said of them, they possess all the requirements wanted, and are every year becoming earlier and superior. The greater portion, however, of these so-called new varieties are merely selections—selections it may be—magnificent improvements on the original, and consequently valuable. New Peas, however—Peas raised by careful cross-breeding—come only to us from the hands of a very select few. The first great Pea cross-breeder was Thomas Andrew Knight, for a long time President of the Horticultural Society, who raised for us many fine sorts remarkable for their thin skins and delicate flavour, not yet equalled; I allude to Knight's Tall and Dwarf White and Green Marrows, &c. Then came the late Dr. McLean, of Colchester, who gave us dwarf and early Marrows, such as Little Gem, Advancer, Premier, &c., of wonderful value. Next, or now, we have Mr. Laxton, who, although he has already done much, will yet do more. He is at present almost our only Pea cross-breeder. There are not many, it is true, who could give the time; there are but few who would have the patience, or the knowledge either. There is no greater enthusiast. And what an enthusiasm one must have for this sort of labour!

No one who has not attempted it can have the least conception of the time or labour that is involved in making a single cross amongst Peas. It may seem most incredible, it is nevertheless the fact, that from a single cross, the crossing of a single flower, some four or five hundred distinct varieties may be procured ere any one form is fixed or fit for sending out, which takes up a period of from five to seven years—that is, from the time of the crossing of the flower.

In the hybridised pod there may be eight peas; each of these when sown will produce from eight to ten pods containing each eight or ten peas—a total of more than five hundred peas the first season. These, according as the cross

may have been, may be either very similar or dissimilar. Mr. Laxton showed me some pods, the produce of a cross between the old Maple Purple and a white Pea, in which every pea was dissimilar—some round, smooth, white; some white, wrinkled; others blue, grey, mottled, brown, green, &c., not any two peas alike. All of these have to be grown distinctly, gathered separately, and again sown, or else discarded, if considered unworthy. These again will sport the following season as before, and more or less for some time. After a time, however, by great care in the selection of the dried seed in winter and "roguing" in summer, they leave off these vagaries, and become what is called "fixed," and fit to send out to the public.

Some new Peas have been sent out too soon—such as Laxton's Prolific Longpod, and this accounts for its mixed character, one portion of the sample being green, and the other white, the true variety, according to Mr. Laxton, being the white one. The condition of this Pea before the public is not due to Mr. Laxton, but to the vendors who had it from Mr. Laxton as an unfixed variety. It will thus be seen that the raising of new Peas and their introduction to our gardens are a most laborious affair, requiring the utmost patience, zeal, and perseverance, and also a considerable outlay, the recompense therefrom being little commensurate with the actual cost, excepting in the gratification of indirectly benefiting mankind.

One of Mr. Laxton's greatest triumphs as yet before the public is, no doubt, *Laxton's Supreme*. The pods of this are very large and extremely handsome. It belongs, however, to a class which is more remarkable for good looks than fine quality. With Mr. Laxton this Pea was not over-grand, whilst with Mr. Gilbert, at Burghley, it was superb. There are other two varieties as large and nearly as handsome as this yet to come out—viz., *Laxton's Quality*, a wrinkled Marrow, and *Laxton's Quantity*, a selection from it. Here we have a line of the green variety of Laxton's Prolific Longpod, a very excellent Pea, and side by side another—Carter's Hundredfold, said to be a cross-bred kind. They are, however, identical, as Mr. Gilbert, an experienced gardener, testifies.

I must just remember *Alpha*, the first step towards long podded early wrinkled Marrows, and a very fine Pea. This is now to be superseded by *William the First* as an earlier still, more wrinkled, and better sort. This is one of the most important introductions in the Pea line which will be amongst us next season, and will completely drive away such tasteless stuff as Ringleaders and First Crops.

I am afraid to speak of the many varieties Mr. Laxton has here, and of such high promise. One batch were from crosses between Ne Plus Ultra and Veitch's Perfection. Most of these were about 3 feet in height, earlier than Veitch's, with pods more nearly resembling Ne Plus Ultra. Then another lot of dwarfs, over one hundred in number, in little short lines, crosses from Little Gem, &c. Here was Little Gem itself as a test sort. All the seedlings were much of the same habit, many were earlier, others larger in pod, &c., some white, wrinkled, some blue, wrinkled. From these I expect something good. This is the style of Pea for general use. Here is another lot

between Alpha and Little Gem, and Ringleader and Little Gem, all showing marks of distinction and promise of merit. From some of these comes a deep green, early, wrinkled Marrow, a wrinkled Pea as early as Saugeter's No. 1, and as green as possible. This is a decided novelty and a great gain.

We have, again, some curious results from crosses of the old purple-flowered Maple Pea, the purple blood of which seems to drive the white Peas mad; they run into all colours, being white, brown, green, freckled, and speckled; something interesting Mr. Laxton will no doubt secure. Again, there are numerous crosses from the Sugar Peas, those of which the pods are eaten like Kidney Beans. What may come out of these one can hardly tell—enormous podders, no doubt. Lastly, and I found them growing at the farthest-off side of Mr. Laxton's garden, were, perhaps, the finest lot of Peas the world has ever seen; they were superior in size and appearance to Laxton's Supreme. I measured one pod which was quite 6 inches in length, full of large peas, and remarkably handsome. This was the last. I cared for no more.—ARCHAMBAUD.

THE GLADIOLUS AT SOUTH KENSINGTON.

THE general details of the Show having been already given in last week's Journal, I am left the more free to enter upon that part of the subject which is more especially grateful to me—not the comparative merits of the different exhibitions, but the value of the different flowers. One or two words, however, I must say. The Exhibition amply bore out what I have ever stated—that if you give real encouragement to a flower you will soon induce people to grow and exhibit it, and the value of such exhibitions no one can tell. If a few prizes of a pound a-piece had been offered, would they have brought men from Kelso, Darnbarrow, Taunton, Edinburgh, &c.? Should we have heard, as we did, the broad Doric Scotch on all sides of us? I am only sorry that we did not also hear the rich unctuous brogue of Cork and Dublin. Perhaps another year we may be so favoured. And assuredly our thanks are due to the Rev. Joshua Dix for having originated and carried out this scheme. Its success will, let us hope, induce him to try it again. I may just as well say, to show the value of such shows, that two of my acquaintances were so delighted with the flowers that they at once determined to grow them, and will purchase a selection of sorts—one of them, at any rate, to exhibit.

It is quite clear that the last two or three years have materially altered and improved the Gladiolus. Varieties that we then thought excellent will bear no comparison with those of later date. The flowers individually are larger, the tendency to be "winged" is less, and a larger number of flowers are opened together. Who, for example, would care to grow *Rose Victoria* when he can grow *Madame Desportes*, or *Napoléon III.* when he can have *Horace*? and hence a great change is seen in the character of the stands. Of the flowers, then, of last year—that is, sent out in the autumn of 1868, the following were shown in fine condition:—

Homère.—A long spike. A sort of light purple flamed with brilliant magenta.

Madame Desportes.—A magnificent bloom of this graced Mr. Kelway's stand. It was of the purest ivory white, with a violet feather in the lower petals.

Madame Dombroin.—Dwarf plant, but vigorous; well-arranged spike, somewhat in the style of *Homère*, but distinct.

Marie Stuart.—A very beautiful blush flower, tinted with rose and flamed with carmine. A most beautiful flower.

Michel Ange.—A very remarkable variety; long spike, dark purplish crimson, light centre, and the flower very curiously displayed—more like a Lily than a Gladiolus. I fear it is delicate in habit.

Monsieur Legouré.—A splendid fiery red, the petals with a white line on them; a grand flower. Vigorous plant.

Racine.—A magnificent spike of this was in Messrs. Stuart and Meis's stand from Kelso. A fine cherry colour stained with violet.

Schiller.—A pale primrose flower, large carmine spots, very handsome.

Agnes is too pointed, *Fœclen* and *Thomas M.* given have the flowers too far apart, *Romulus* is too loose, *Virgile* fine in colour, but somewhat starchy.

The eight above mentioned were all fine, and all shown in good condition.

With regard to the flowers of 1870—that is, those let out

last autumn, the following were shown well, and are worthy of a place in any collection:—

Armide.—A grand spike of this was exhibited by Stuart and Meis. It is a white ground tinted with carmine.

Agathé.—Fine spike of large flowers; light ground tinted with orange.

Delicatissima.—A beautiful light, delicate violet flower, well deserving its name.

De Humboldt.—Cherry red tinted with purple, somewhat of the colour of *Michel Ange*.

Horace.—Red with white spots, of the same style as *Napoléon III.*, but greatly improved.

Orphée.—A magnificent spike of this was in my own stand; it is a fine flower, rose ground flamed with carmine.

Robert Fortune.—Carmine-flamed, crimson centre.

Rosa Bonheur.—White, with a deep violet carmine spot. It has a peculiarity of doubling back the top petal, which a little detracts from its beauty.

Rosa Perfecta.—Rose-tinted violet, each petal marked with white.

There are others yet to be decided on, such as *Bijou*, *Livingstone*, *Elizabeth*, *La Candeur*, *Pericles*, *Spectabilis*, *Sylphide*, and *Sultane*, about which I may have to say more by-and-by.—D., Deal.

THE STRAWBERRY SEASON OF 1870.

I CONSIDER a dry season the best for Strawberries; it causes no diminution in the quantity of the produce, and the quality is vastly improved. Of course abundant supplies of water must be administered. Take, for instance, that fine but peculiar Strawberry *Dr. Hogg*; in a wet season it is very indifferent, but in a season like the present it has been unsurpassed.

The rainfall for the first six months of the year was not much more than half the usual quantity. In January we had 1.59 inch, in February 0.22 inch, in March 1.76 inch, in April 0.40 inch, in May 0.56 inch, in June 0.15 inch; in all 4.98 inches. Excepting by well-watered plants no runners were formed. The superiority of young plants was easily determined this year; the value of deep cultivation and high manuring equally so. For pot culture *Black Prince* is still grown as the earliest variety; it is a sure bearer, and always colours well. For the second crop *Premier* was grown this year, succeeded by *President*. *Premier* is not first-rate as regards flavour, but is a most robust grower, and bears an immense crop of large fruit of a bright dark red colour. *President* is one of the best both for pot culture and out of doors. For late bearing *British Queen*, *La Constante*, *Mr. Radclyffe*, and *Frogmore Late Pine* are most esteemed. *Dr. Hogg* is generally very deficient in colour when grown in pots under glass, although the fruit are of the largest size of any. *La Constante* is a great favourite; it is not to be compared with *British Queen* or *President* for flavour; the flesh is very firm, and it is the best variety to keep after it is ripe. The fruit is of a brilliant crimson.

The main point in successful cultivation is to have the runners layered early, and let the plants experience no check to their growth afterwards. The pots ought to stand on a hard bottom, and means should be taken to prevent the ingress of worms through the holes. I set each pot singly on a brick; the plants are by this method more fully exposed to the sun and air, and worms are effectually excluded. If bricks cannot be obtained the next best method is to form a bed of coal ashes, heat it hard, and make it perfectly level with a rake. Out of about 250 grown in the orchard house there were not more than two or three barren plants; two or three more were turned out because of weak or badly formed trusses.

Lucas and *Sauveur de Koff* I limited for the first time this year. They are both good. *Lucas* is the stronger grower and superior to the other. I think it will displace *La Constante*. I cannot concur in Mr. Glöck's estimate of *Sir Joseph Paxton*; it sometimes does well, but is uncertain and very much subject to mildew; for the last-named reason alone I have discarded it. Mr. Webb's estimate in the same page (99), is also very different from mine. The reason must be the difference in soil and climate. *Lucas*, *President*, *La Constante*, and *British Queen* he depends. I consider them four of the very best sorts in cultivation, and grow them largely both in pots, and out of doors. The soil here is of a light sandy nature, and not far from the gravel. I have planted sixteen varieties this year, and the best six of them as grown here are *President*, *Lucas*, *La Constante*, *Mr. Radclyffe*, *British Queen*, and *Frogmore Late Pine*. *British Queen* might be omitted, as it is not sufficiently

distinct from Mr. Radclyffe, and Premier substituted, as it comes in before President.—J. DOUGLAS.

DOUBLE GERANIUMS, AND WHAT THEY MAY BE.

AMONG the plants to which the present dry season has been favourable may be ranked the double-flowered Geraniums, which have gained friends where before they were merely tolerated as novelties. They have flowered well this season, and most likely there will be an increased demand for them next year. I fully expect in a very few years they will take a higher position in the flower garden than their most ardent admirers ever dreamt of, when varieties are produced possessing the necessary qualifications for an out-door plant, which those we now have scarcely do. Their well-doing this year is, I think, due to the exceptional character of the season, but I hardly expect the same success in future; for, as I write on August 10th, it is only reasonable to look for a greater amount of moisture during the remainder of the summer than we have yet had; and with that I expect the evils of former years will reveal themselves in the double Geranium; those evils being a gross leafy growth, with few flowers, and these apt to decay before making any show. Even the long dreary nights will accomplish this in a measure, whether there be rain or not.

I think with varieties having a greater disposition to flower than those we now have, and possessing some other properties which I shall notice, we may expect greater success than we have yet had. I venture to predict for the double-flowered Geraniums a more extended area of usefulness than the Tricolors are likely to have, and this is saying much in the face of the class in whose honour special prizes, nay special shows, have been given; but great favourites are not always lasting friends, and I expect half a dozen years hence double Geraniums will be more extensively cultivated than these sickly fashionables of the present day. As double flowers, in general, retain their individual beauty longer than single ones—for instance, the double Cherry, Peach, Stock, Rocket, and others—there is no reason why the Geranium should not do so also. The principal defect seems to be a disposition on the part of the centre of each truss of flowers to decay before we would like it to do so, and no doubt it is owing to the absence of rain, and very often dew, during the present season, that has preserved the flowers longer than usual. As there is no limit to improvement in flower culture, there is reason to hope we may hereafter be favoured with varieties capable of withstanding the destructive influence of moisture. Witness what was done with the Pansy many years ago; its thin flimsy petals were taught to assume a stiff, leathery substance, and to stand up unscathed against the fierce sun of midsummer; may not the Geranium also be brought to resist decay when it comes in the shape of moisture rather than lack of vitality? To accomplish this, however, I believe we must abandon some of the points insisted on by what may be called the red-tape class of florists. The code of laws they have laid down for the guidance of cultivators of this and other florists' flowers must be disregarded, and the compact truss or head of bloom so much insisted on ought to be transformed into a rather loose one. The individual flowers should be sufficiently far apart to let the air circulate freely amongst them, and, consequently, enable the blooms to shake off the moisture much sooner than they do now, and most likely a prolonged blooming period will be the result, especially if in addition to the quality referred to the plant also possesses a disposition to flower as abundantly as some of the single ones now do. I merely throw out these hints, thinking they may be of service to those who may be experimenting, and if in the course of their experience they produce a good double flower that is set somewhat loosely upon its stem, they should not throw it away until after a trial out of doors, and perhaps it may turn out better than some conforming more closely to the present standard.

As I have not been at many horticultural shows this season, I may not have seen the last new varieties of this section of Geraniums, but I hardly think those who supply the public with such flowers would venture to present them with a loose, open-headed one like that I have been describing as likely to be useful for out-door purposes. Variety is certainly wanting in another direction. Good whites, and other light-coloured kinds seem to be scarce, and yet they are as desirable as scarlets. Time, however, I have no doubt, will supply us with all these kinds; and with such good flowers as Wilhelm Pfizer, Marie

and Madame Lemoine, Andrew Henderson, Triomphe, and others, to begin with, flower-garden requirements will probably be met. By-and-by, when our Mrs. Pollock, Lady Cullinm, and others have to retire to the drawing-room, our flower beds may come out in all their glory with double Geraniums in sufficient variety to enable everyone to have his button-hole supplied with one.—J. ROSSON.

THE ONION CROP.

IN December last I trenched a piece of ground 25 yards square, to the depth of 2 feet, just deep enough to bring 3 inches of clay to the surface. After it had remained in a rough state for six weeks I forked in a good quantity of strong manure—principally refuse from the garden—and on the 10th of March sowed the seed in drills 18 inches apart. One half of the ground I sowed with the Nureham Park, the seeds of my own sowing; the other half I sowed with Danvers' Yellow and Giant Race.

To-day (August 15th), I have measured some bulbs of the Nureham Park, and I find that they are fully 13 inches in circumference. The largest of Giant Race are 11 inches in circumference, and Danvers' Yellow 10 inches. They have not had a drop of water except that which has fallen from the clouds, and we have only had very little here.—A. DONALDSON, *Latimers*.

ARAUCARIA IMBRICATA AT BICTON.

IT may be interesting to your readers to hear something about the Araucarias at Bicton in the present year. From two trees in the Araucaria avenue we have already gathered upwards of five hundred perfect seeds, a specimen of which is enclosed, and from several other trees, on which the cones are not yet ripe, we may safely calculate on securing at least five hundred more. The cones from which the produce here stated was taken averaged fifty perfect seeds to each; it may therefore be inferred that the Araucaria, when it arrives at maturity, will be a most productive tree.

There are in the nursery here only thirty plants averaging 1 foot in height which have been raised from seeds ripened at Bicton; and three others that were some years since planted in the pinetum average 1 foot 6 inches high. From the above data it is presumed that the Araucarias at Bicton have produced very few seeds in former years.

When writing on this subject it may be worth recording that the last year's seeds of Picea Nordmanniana, P. Pinusapo, P. amabilis, and many other good species have germinated very freely here this season; it is therefore hoped that those to whom my noble employer requested me to send a supply have been equally successful.—R. BRADY, *Bicton Garden*.

The seed sent was very fine, plump, and perfect.—Eds.]

PEA CULTURE.

I AM interested in Mr. Luchhurst's suggestion for protecting early Peas, at page 77; but would not the same end be answered, and the trouble of making the boxes be saved, by adopting for the first the plan he recommends for the subsequent growths?—say, by dusting the seed well with red lead, sowing as deeply as is consistent with good practice, sowing thickly, and then putting on the glass—laying it on the ground I mean. I assume that, apart from the red lead, mice do not mind seed when germinated, and although sparrows will take off the young tops, if the plants come up thickly they will not take all. Would it not be useful to mingle plenty of blacksmiths' ashes in the drills before sowing? The sharp ashes from the forge must tend to keep off slugs, &c.—H. VENTNOR.

CALIFORNIAN CONIFERS.

MR. HOBBS, in his excellent description of the Pines of California (pages 80 and 81), confounds Abies with Picea. The Abies has hanging cones with persistent scales. The Picea (amabilis and grandis) has upright cones with deciduous scales, and, as he justly remarks, the leaves bear two rows; they have likewise two white lines on their under side. This is a distinction which gardeners seldom notice, and it makes it very puzzling to botanists and those ordering of trees. It is not to be found in Bentham or an English flora, as the country does not furnish either specimen; but the whole family are excellently dis-

tinguished in Loudon's "Arboretum et Fruticetum," a work which is still to be had at old bookstalls; I bought mine at one, and it is well worth the small price the two volumes can now be had for. If it were better known, our gardeners' lieta would be greatly improved, and better understood by accurate students, who are their best friends.—B. H. W.

GARDENING IN THE LONDON PARKS.—No. 1. BATTERSEA PARK.

THE modern style of flower gardening has probably done more than anything else to draw the attention of the gardening world to the importance of a knowledge of the relative value of colours, and to the cultivation of correct taste in the arrangement of them. Like the painter or sculptor, we strive to obtain a sight of the works of masters in the art, not altogether with the view of closely imitating what we see, but rather to endeavour to grasp the intention of the artist, to see what his aim has been, to study the general effect of the whole, and so render the lesson useful to ourselves by applying its soundest principles in our future practice.

It was with some such thoughts as these that I went to see the flowers at Battersea Park, Hyde Park, and the Crystal Palace, and it is my purpose in these notes to give some description of what I saw at each place, with the hope that it may prove useful and interesting to those who are prevented by distance and other causes from seeing and judging for themselves.

Taking them in the order in which they are named, Battersea Park worthily occupies the first place, not simply because the tropical plants are its chief feature, but because at Battersea one sees evidence of great skill and ability in the singularly appropriate manner in which the grounds have been adapted for their intended purpose. The winding walks, the gently sloping banks, the abrupt eminences, the sheltered nooke, and the pleasant glimpses of water, all contribute to the formation of such a scene of beauty as is rarely to be met with; and at this season, when to all these fine permanent features are added the host of fine-foliaged plants from the tropics, which, by the skill devoted to their arrangement, display their curious growth and foliage to the greatest advantage, these gardens may be said to be quite unique, so skilfully has the Superintendent availed himself of the rich variety which the graceful forms and varied hues of the tropical plants afford—the novel effects succeeding each other so constantly that the interest excited by the first glimpse is fully sustained in every part of the subtropical garden.

In designing these grounds the aim of the artist was evidently to obtain as much shelter as possible, in order to screen the large foliage of the tropical plants, which soon loses its beauty if at all exposed to violent winds; this shelter is obtained by causing the walks to wind about in graceful curves, so as to form a number of semicircular spaces, behind which rise banks well clothed with a variety of trees and shrubs, the growth of which, while it is void of all stiffness or formality, is kept beautifully graduated downwards till it meets that of the plants it is designed to protect. As an example of how well this is done, I will instance one group of beds occupying the space in front of a long sweeping curve. Towards the highest part of the bank is a broad belt of Lilacs, next below this is a row of variegated *Aucuba japonica*, then a fine bold line of the dark-flowered *Nosegay Pelargonium Waltham Seedling*, next this a row of *Golden Pyrethrum*, with a front row of *Stachys lanata*. Close in front of this bank, at the centre and deepest part of the curve, is a fine long bed having lines of *Canna discolor* behind, then *Canna expansa rubra* of lower growth and with dark-coloured foliage, and a row of *Pelargonium Golden Fleece* in front. This bed has a very bold and striking appearance. In front of it, near the walk, are three circular beds, the middle one containing in its centre a splendid *Cycas revoluta*, with its elegant fronds spreading gracefully over a mass of *Coleus Albert Victor* beneath, while around the *Cycas*, but not near enough to crowd it or affect its beauty, were smaller plants of *Latania borbonica* and *Chamserops Martiana*, with an edging of the pretty grey *Santolina lavandulifolia*, which gave an appropriate finish to the whole. Of the other two beds, one contained a compact mass of *Lilium lancifolium rubrum*, and the other a crimson scarlet *Pelargonium*; both beds had edgings of *Centaurea gymnocarpa*. A few Palms springing from the turf among the beds imparted grace and lightness to the entire group, which is but one among many others equally striking and effective.

Another very long graceful curve, having, like the rest, its sloping bank of shrubs, had all round the curve at the base of the bank, but raised 2 or 3 feet from the actual level, a number of small semicircles cut into the bank, on each of which was enthroned a noble *Musa Ensete*, surrounded by other tropical plants. On the level surface of the turf, at the foot of the bank, were some fine groups of *Cannas* and various other fine-foliaged plants, interspersed with good specimens of *Scaevola elegans*, *Cordyline indivisa*, a fine *Latania borbonica*, and a beautiful plant of *Areca sapida*. In front of this group, on the turf beyond the walk, were a number of beds, some containing varieties of *Cannas*, and all interspersed with handsome specimens of *Palma*. A novel effect was here produced by a long narrow bed, the curves of which were so close to each other as to form a number of small semicircles, each of which embraced a neat circle of green Ivy; the sides of the bed were faced with a thick compact hedge of *Euonymus radicans variegatus* nearly a foot high; the soil of the bed was almost level with the top of this hedge. A broad line of *Pelargonium Cybister* ran along the centre of the bed, with a row of *Pelargonium Golden Fleece* on each side. This bold mass of colour lost all its harshness by the proximity of so much green foliage.

At another part of the garden is a fine group of *Acer Negundo variegatum*, occupying an elevated and commanding position in front of a belt of dark-foliaged shrubs. Passing round one of the numerous curves one cannot fail to admire the fine effect produced by this mass of silvery foliage, which is so placed that a walk leads straight to its centre, where the tallest plants are placed, the whole group being so arranged as to elope gently downwards from its centre to the outer row. A short distance from this group a striking contrast presents itself in a number of *Yuccas* clothing a steep bank.

A fine effect, different in character, and certainly as novel in design as any group to be found in the entire garden, is produced by four beds on the turf, in a line parallel to the walk; two of these beds are parallelograms, and two are circles; all of them are planted with the same kind of plants, but with the colours arranged in different designs. The soil of these beds, in common with that of most others here, rises abruptly from the turf, and thus a miniature ramp having a sharp slope is formed all round the beds. On the face of all the beds is a neat row of *Echeveria secunda glauca*, and in each of the long beds a band of *Alternanthera paronychioides* runs all round next the *Echeveria*. Along the centre of each bed are three separate small scrolls of *Golden Pyrethrum*, with a small star of *Santolina incana* on each side of the central scroll. Closely surrounding these, and entirely covering the remaining surface of the beds, is a compact mass of the splendid *Alternanthera amœna*, with foliage of a deep pink or crimson shade. In the circles a band of *Alternanthera amœna* is outside next the *Echeveria*, then comes a band of *Santolina*, then *A. amœna* again, then *Golden Pyrethrum*, then more of *A. amœna*, with centres of *Santolina*, the *Pyrethrum* forming a number of vandykes, the spaces of which are filled on each side by the colours given above. Behind these charming beds are two masses of *Cannas*, with an edging of the dull grey *Veronica incana*, the quiet tone of which acts as a capital foil to the bright colours in the front beds. I have described this group fully, because the plants themselves, and the pretty designs into which their colours are interwoven, are such as are suitable for any flower garden however small.

Passing from this bright scene round one or two curves we come upon another equally striking, and far more uncommon—the miniature Alps, with their summits clothed with *Antennaria tomentosa*, which really conveys a very good idea of the perpetual snow it is intended to represent. From the "snow line" downwards to the ravine and lower slopes of the "mountains" are a host of alpine plants, the majority of which are of such diminutive growth that the plants of *Echeveria metallica*, which are interspersed among them, tower above them like giants. The quaint forms and the dwarf, compact growth of this rich collection of alpine plants offer an interesting study of a class of plants but too little known; the agreeable and natural manner in which they are here seen growing, and the novel effect of the whole scene, are also well calculated to fix the visitor's attention.

Turn we now to a very different scene, but quite as effective in its way, at another part of the garden, in a quiet nook, shut in and overshadowed by the spreading branches of trees. On one side of the walk is a group of *Tree Ferns*, so disposed as to exhibit the full beauty of their graceful proportions, and on the other side a narrow glade stretches away till it is lost among

the trees. All along the sides of this glade are Tree Ferns, their graceful fronds almost touching each other, and spreading out over other kinds of more lowly growth, forming a charming vista full of quiet beauty and repose.

Having thus given a sketch of some of the most striking scenes with which these gardens abound, I will now proceed to describe a few of the principal beds, most of which occupy raised spaces on the banks by the sides of the walks. A good effect was produced by a broad band of *Canna Rendatleri*, with abundance of its orange-coloured flower spikes; in front of this was a row of *Solanum laciniatum*, with deeply serrated foliage and pale blue flowers, and outside, an edging of *Amaranthus melancholicus ruber*. Another bed had a band of *Canna limbata*, with pale green foliage; in front of this was *Canna zebrina coccinea*, of medium height, with bronze foliage, having a handsome edging of *Santolina lavandulifolia*. A bold mass of *Wigandia caracasana*, with broad deep green leaves, had a fine effect, somewhat spoilt, however, by the rough and unsightly stakes supporting the plants. Another interesting bed contained the curious *Solanum pyracanthum*, with narrow foliage deeply serrated, having a number of spines or thorns of a bright orange colour on the stems and the upper sides of the leaves. In front of these were some plants of *Amaranthus tricolor*, with the rich leaf-markings beautifully developed. A long border contained *Canna limbata* and the fine *Canna Bihorelli*, with a good edging of *Scarlet Pelargonium*; another had two rows of *Canna purpurea spectabilis*, a fine variety, with deep bronze foliage. In front of this was a row of *Canna Sellowii*, a dwarf kind with green foliage; the edging was *Pelargonium Golden Fleece*. A mass of *Canna zebrina coccinea* was surrounded by a row of *Pelargonium Dr. Lindley*, with an edging of *Statice* in fine flower; this bed would have been better without the *Pelargonium*. In another bed was a fine, bold mass of foliage, consisting of *Canna limbata*, with *Ricinus purpureus*, and with an edging of *Funkia subcordata*. A circular bed of *Coleus Berkeleyi*, interspersed with *Abutilon Thompsoni*, had a very novel effect. In another bed was *Solanum macrophyllum*, with *Solanum marginatum* next it, then a row of alternate plants of *Amaranthus melancholicus ruber* and *Golden Chain Pelargonium*, with an edging of *Sempervivum montanum*. A fine effect was obtained in a circular bed by planting the centre with *Coleus Prince Arthur*, out of which sprang a few small *Musas*; round this was a row of pink-flowered *Lantanas* (*Delicatissima*, I think), with an edging of dwarf *Ageratum*. Another bed had a central mass of *Coleus nigricans*, out of which sprang a number of *Abutilon Thompsoni*; round this was a handsome line of *Pelargonium Daybreak*, a very fine variegated kind, the foliage having a broad silvery margin, and next this was an edging of the bright crimson *Alternanthera amœna*. This was a very handsome and attractive bed. Some of the beds were bordered with a broad line of a gold-blotched *Ivy* (*Hedera Helix aureo-maculata*, I think), which looked well. Many of the variegated *Ivies* are very valuable for this purpose. A small circle had a pretty design, formed of *Alternanthera apathulata*, *Golden Pyrethrum*, *Blue Lobelia*, and *Santolina incana*. Nor must I omit some good groups of *Ficus elastica*, conspicuous by their glossy green leaves and long, crimson, taper buds.

From other groups I may select *Polymnia grandis*, *Arundo Donax variegata*, *Canna metallica* with very dark rich foliage, and *Canna expansa*, a dwarf kind with bronze foliage, as plants possessing distinct and striking features. One or two lines of *Artemisia Stelleriana* had a very dull and ragged appearance, and it was to be regretted that so paltry a plant, without one good quality to recommend it, should find a place among so many plants of sterling merit. Some lines, too, of *Plumbago capensis*, though not so objectionable, were somewhat ragged in appearance, and had a very scanty crop of flowers. It must, however, be acknowledged that in the entire garden there was little, if anything, to cause one to indulge in a "growl;" on the contrary, the very high degree of skill exhibited in the selection, arrangement, and culture of the plants, their health, vigour, and uniform excellence, and the neatness and order which everywhere prevailed, all formed cause for hearty congratulation to all concerned.

I must not conclude this notice without referring to the numerous healthy examples of *Palms* and other fine-foliaged plants interspersed among the beds. The kinds most worthy of note were—*Phoenix reclinata*, *Chamærops Fortunei*, some fine plants of the elegant *Cordylina indivisa*, *Scaevola elegans*, *Ferdinanda eminens*, *Areca sapida*, and our old friend *Chamærops humilis*, a fine *Musa superba*, and nobler than all

the rest, the splendid *Musa Ensete*, the Abyssinian *Banana*. The largest plant of this was probably 12 feet high; one enormous leaf springing erect from its centre was perfect, but most of the other leaves had apparently been lacerated by wind. This stately denizen of the tropics has its stem sheathed in the bases of the leaves, which spring upwards and outwards, often being 10 or 12 feet long. Though attaining such noble dimensions the texture of the leaf is of exquisite delicacy; the bright red midrib, standing out boldly from the under surface of the leaf, contrasts most beautifully with its lively green colour. Beautiful as the plant is at Battersea this summer, it must be seen growing under the shelter of glass to be fully appreciated, for there its huge foliage acquires a delicacy of appearance far surpassing that which it presents in the open air. The fine plant growing in the Crystal Palace is well worthy of inspection.

The able manner in which all formality is avoided in the gardens at Battersea is an important consideration, for sure I am that a much greater degree of enjoyment must be derived from pleasure grounds so beautifully diversified, and offering such a charming contrast to the flat monotonous style which has hitherto obtained an almost universal adoption than from the latter; but this is a subject which to my mind is far too important to be dealt with here, and I therefore propose at some future time to devote a paper specially to it.—EDWARD LOCKHURST, *Egerton House Gardens, Kent*.

BEEET FOR DECORATIVE PURPOSES.

Or the many subjects that within the past few years have been pressed into the service of the flower gardener, there is none which seems to me so much out of place and character as Beet. Look at it as we may, intermix it as we choose—whether in the front or at the back of a border, near to the eye or distant from it—the impression given by the dark bronzy purple foliage of *Dell's Crimson* is that of a kitchen garden, whilst the *Chilian Beet* reminds me of a field of *Mangolds*. Flowers in a kitchen garden may be tolerated, they are there for a purpose—to afford cut flowers; but for vegetables in a flower garden there can be no such excuse so long as suitable plants having no culinary use can be found. But are there no plants so good as Beet? I imagine there are, and better subjects for a flower garden.

Dell's Crimson Beet is the most compact and close-growing, and it has the property of keeping well furnished at the base, the root being hidden by the dense leaf-growth even in a front line. The foliage is *Dracæna*-like, arches over from the centre, and its colour is very uniform. Individual plants hardly vary in this respect, but present a dark bronzed purple, a hue that may well be termed metallic. They are very regular in growth and size, and there are no "runners"; indeed it is by far the best variety I have seen. Of its value as a decorative plant there can be no question. It is much bolder, has more of an oriental aspect than any of the *Iresines*, *Amaranthuses*, or *Alternantheras*, and may be used with or without them. Unlike them, however, it is hardy, does not require to be reared in pots, and takes up no time nor house room. It may lie in the seed-closet until April, and then be sown where it is to do its duty. Besides, it comes in for the table quite as well as Beet grown in the kitchen garden. It will grow in cold localities where *Iresine*, *Amaranthus*, and *Coleus* do not succeed, and it is equally at home in a wet cold summer as in one like the present. It is just the plant for places where a mass or lines of a dark purple colour are required with the least amount of labour and expense. But it is only a Beet; if one can get over that, which I cannot, it will not fail to please.

Sown in April it attains a good size by the end of June, and is in its beauty all through July, improving as the season advances, and is never finer than when taken up in November. The first or second week in April is when I should sow it in order to have it in condition in July, but I would not sow until the first week in May if it were not wanted to produce an effect before August. Of course it will grow in any soil. Sow the seed in drills, cover with light soil, and thin out the seedlings to 9 inches apart. Some sow in pans and transplant, but I do not perceive any benefit in the practice; on the contrary, if the weather be dry after transplanting many plants will probably run to seed and must be pulled up, spoiling the mass or line. I have not seen a more select stock than *Dell's Crimson*. It remains to be seen how long this Beet will continue true to its characteristics.

Of the *Chilian Beet* I cannot say much, this being my first

year of growing it, but unless it prove better than it has done, I shall discard it. The seed was obtained from a first-class firm, so that I have no reason to doubt its being true to name. The plants vary in the colour of the leaves; some plants have yellow stalks and veins, others red, but of the "deep waxy orange," and "vivid polished crimson." I have not seen any more than are developed in yellow or red Mangold, whilst the growth is coarse—very different from the refinement we aim at in flower borders or beds. It may do for shrubby borders, but not, I think, for flower gardens; in fact, I do not see why the Silver Beet should not have a place as well as this novelty. In the same way we might adopt in the flower garden other kitchen-garden plants. Where is there a more stately plant than the Globe Artichoke, so silvery in its foliage, and what plant has such a finely cut foliage as the Carrot?

The Chilian Beet I shall not grow again unless some one seeing it (and I have it in all the colours spoken of by "Q. Q."), should between now and November express himself in its favour. I have it in a conspicuous part of the kitchen garden; no one but myself seems to notice it—proof enough of its little attractiveness and beauty. In the flower garden I have no doubt it would soon be noticed, and might be thought from its novelty very beautiful, until it became known that it was nothing more than Beet with various-coloured leaves, green largely predominating in all.—G. ARNEY.

A GLIMPSE OF THE ROSES IN THE NORTH AND SOUTH.

I HAVE received the following communication from Mr. Henry Taylor, of Fenscote, Bedale, Yorkshire. It is reliable, as he is a first-rate propagator, cultivator, and judge of Roses, and not a mere scribbler.

"I have been to see Mr. Harrison's Roses, at Darlington. He has 20,000, one-half on the Manetti stock, and the other half on the Briar; both are fine, but he has a strong clay soil, which suits the Briar. Amongst the Roses of 1870 these were good—Albion, Baronne Chaurand, Blanche Meun, Ferdinand de Lesseps, Louise Wood, Eugénie Verdier, of immense size and the best of the year. The following were good and promising:—Jules [Semre?] Madame Dustour, Jeanne Guillot, La Motte Sanguine, good and free; Charles Lee, Henri Ledebaux, Clémence Raoux, Leopold II., Black Prince, Madame Norman, Ville de Lyon, Marquise de Montmart (properly Montmartre). Teas—Belle Lyonnaise, Adrienne Christophle, Madame Levet, Montplaisir. He marks the following Hybrid Perpetuals as extra fine:—Monsieur Woodfield, Nady Fibres, Felix Genero, and Thyra Hammerich." He adds further on in his letter, "Madame Auguste Verdier is a magnificent Rose, very large and perfect, a new Rose." Then again, "Velours Pourpre of 1866 is one of the best dark Roses, a fine Rose not much known. I have budded it."

At the same date I received a letter from my esteemed friend, Mr. William Paul, in which he says, "I am of opinion that Felix Genero is quite first-rate."

Roses are now blooming well again here. What a wonderful stock is the Manetti! We are told that we cannot grow Roses big enough for exhibition except on Briars. Such is a fallacy. The Rev. Mr. Going, vicar of Walworth, came here with his friend Mr. C. Ingram, and, being astonished at the size of the Roses, he measured with my marked tape one Rose, and found it to be 6 inches in diameter. I have had numbers of Roses 4 inches and over. What a man does, and what he can do and ought to do, are two different things. I brought down on myself satire, sarcasm, and the sardonic laugh some years ago for saying what I shall now repeat, that we have lots of possessors of Roses, and prize-winners, and scribblers, but very few experienced Rose-cultivators!

The best of the Roses of 1870, so far as I have been able to try them, are Princess Christian, Mademoiselle Eugénie Verdier, two beauties of great substance—on important point—and Marquise de Castellane.—"D., Deal," brought here beautiful blooms of Louis Van Houtte. My plant has made no sign.—W. F. RADCLIFFE.

VINE PESTS.—Many of the continental vineyards have been attacked this year by a grub which infests the roots of the plant. M. Marchand proposes the extermination of this pest by watering the soil with sulphureted hydrogen water, which

is well known to be very fatal to small animals.—(Student and Intellectual Observer.)

[This doubtless refers to the Phylloxera vastatrix.—Ens.]

SOME FLOWERS AND GRASSES SUITABLE FOR DRYING.

POSSIBLY some of your numerous readers who do not possess a stove or other heated structure in which to grow flowers all the year round, find it at times very difficult to obtain them for the decoration of the dinner-table and other purposes of house ornamentation. To those so situated I would recommend the following flowers and Grasses, all of which come under the general head of Everlastings, as suitable for drying, and so capable of being turned to account when fresh flowers may not be obtainable.

Of these the Helichrysums are a most interesting class of plants. They are easily cultivated, and, if the flowers be cut before the disc becomes fully expanded, will retain their colour for upwards of two years. *Rhodanthe Manglesii* and some of its varieties are also well worth growing for the same purpose, but they require a warm situation. *Ammobium alatum* is another, and, as its generic name indicates, will thrive in a poor sandy soil. *Waizia*, or *Moraa grandiflora*, I may mention, requires the protection of glass, unless in the more southern counties of England, where it may be planted out of doors after the middle of June. The *Aphelexis* is allied to the *Helichrysum*; all of the species are greenhouse evergreen shrubs, but they are not all hardy. The *Staticee* are a numerous class, and so useful that they must be included in this list. Several kinds of *Gnaphalium*, together with the varieties of *Gomphrena globosa*, or the Globe Amaranth, are more or less pretty, especially the latter, and well deserving more extended cultivation. *Humea elegans* is not by any means to be despised. When dried, its bronzy-red spikes show to great advantage when other things of the same character are not so plentiful. The *Xeranthemum* is a true Everlasting; the flowers, after being dried, may be, and are, dyed of any colour, and it can be grown from seed sown in the open border. *Acerelinium roseum* must also be in this list. Many others might be named, but these are sufficient for the purpose at present.

In the way of Grasses, as suitable for use with the above-mentioned, the following will be found to afford much satisfaction to those who have not hitherto grown them, and are not well acquainted with this elegant tribe of plants:—*Agrostis argentea*, *A. pulchella*, and *A. nebulosa*; *Briza maxima*, and the lesser species, *B. gracilis*; the graceful and useful *Eragrostis elegans*; *Lagurus ovatus*; *Stipa pennata*, or the common Feather-grass of the seed shops, a British plant capable of propagation either by root-division or by seeds, and will grow in any common soil. The Pampas Grass is also found useful; the elegant and stately inflorescence of this fine Grass can be easily preserved, and retained in use for a considerable time.

Such are a few of the more useful of flowers and Grasses capable of preservation. Those unaccustomed to their use are scarcely aware of the excellent effect they have when grouped in epergnes and such-like for the decoration of the dinner-table.—(The Gardener.)

CHAPMAN'S PATENT FLOWER-CASES.

I AM convinced that these cases must come into very general use. I lately sent by rail to a flower show twelve blooms of cut Roses, and they arrived without a petal shaken; and to the Royal Horticultural Society's late Show at South Kensington I brought up twelve *Gladiolus*, which won the first prize, and I took them home again without the least damage. It was the first case for *Gladioli* Mr. Chapman had made, and all who saw it were delighted with its success. The comfort of merely having to take out your box and put it on the exhibition-table is something to be grateful for.—D., Deal.

THE FLOWER TRADE OF ST. LOUIS.—It is but a few years since the entire flower trade of the city was in the hands of a few old women, and the list of flowers on sale was of the most limited character. St. Louis was held up in contrast with Chicago and other cities, and denounced by interested strangers as displaying an utter want of enterprise. We have watched the indications of progress in this direction, especially during the last ten years, and find an amazing expansion and develop-

ment. We have now commercial floral establishments, green-houses, gardens, &c., that are a credit to the community, and an illustration of progress in the love of the beautiful that cannot fail to work a marked effect on the health and moral character of the community. The total sales for a single week this spring come to the very neat amount of 3550 dols. The annual sales of a single firm for several years amounted to 12,000 dols. In regard to the character of the stock for sale, it embraces every article in the greenhouse, conservatory, and open garden; with all the equipments for parlour, window, and table floral ornamentation. In the department of bouquets and cut flowers what amazing progress has been made. The finest flowers of the garden and conservatory, arranged in the most artistic styles, with all the most recent accompaniments, as rich and costly holder, vases, baskets, &c. The houses and grounds are generally in excellent order, and the collections embrace everything new as it comes out in every department of floriculture, whether in Europe or the United States. The displays made at some of our fairs and horticultural exhibitions fail to furnish an adequate idea of the variety or extent of the floral trade of our city, and this is yet in its infancy.—(*Rural World*)

KENFIELD HALL AND ITS CONIFERS.

In passing by the South-Eastern Railway through the Weald of Kent the traveller remarks that it is a level tract highly cultivated, plentifully interspersed with woods and coppices, Hop gardens and orchards; that there are small meadows and equally distinctive corn fields separated by hedges of every conceivable shape, with considerably more than the usual number of dwelling-houses met with in a purely agricultural district, only it is still in these buildings are seen until one is close to them, as the woods and orchards conceal the comfortable farm houses and cosy cottages with which the district is studded. No high embankment gives the traveller a distant view, and only occasional gaps in the almost continuous line of coppice, trees, orchard, or Hop garden that hem in the railway afford glimpses of farm-objets. It is only when the train pulls up at Aford that another kind of scenery presents itself, especially if the journey is made in the direction of the ancient city of Canterbury. The heavy Wealden clay and comparative flatness give place to gently rising hills, which by degrees assume greater altitude, and gradually Hop gardens and orchards give place to corn fields of considerable magnitude, and should there be any portion of such fields in tillage, the colour reveals at once that chalk predominates. Corn and green crops are the principal objects cultivated, the valleys being meadow land, with now and then orchards and Hop gardens, and it is not unusual to see the crests of the hills clothed with wood. This undulating country bordering the valley of the Stour between Asford and Canterbury, along which the line of railway runs, is not without its interest. Occasionally mansions are seen, and still more frequently the parks attached to them. The parks of Eastwell, Godmersham, and Chilham Castle form conspicuous objects along the line of route, but it is to one some distance from the railway that I would here more especially call the attention of the reader.

About three miles eastward from Chartham station and six from Canterbury is Kenfield Hall, one of those commodious brick edifices whose erection might, perhaps, date from the beginning of the last century. The road thither from Chartham leads over some of those chalybeate downs which afford such excellent materials for roads; flints in great quantities were to be seen wherever the surface was not hidden by the crops, for these uplands were invariably arable land, the valleys being generally meadows; but care had been taken to break the largest of these stones, so that rarely was anything larger than ordinary road metal to be seen, so that the action of the harrow and other agricultural implements should not be impeded.

Passing along the crest of one of these ridges some little distance, we at length obtain a glimpse of the residence we are bound for, occupying a position on a sort of natural terrace facing the north, and overlooking the valley which lies between us and the grounds. The house is so well sheltered by timber that only a portion of it can be seen at a time until it is nearly reached, when its elevation is found to be more than might be expected, although there is still higher ground to the south of it. The carriage front is at the north side, the various offices being to the west, while a more spacious front opens to the south, where there is a neat and well-stocked flower gar-

den. The dressed grounds, occupying many acres, surround the whole on all sides but the west, which abuts on the park. The mansion and grounds are in the centre of a well-wooded park of large size, and sufficiently broken by undulations to render it interesting without being romantic. The character of the soil is much superior to that of the downs I have noticed. The soil of the dressed grounds, including the pinetum, is a rather stiff loam, such as one often meets with at the base of chalky hills, and much deeper than is generally the case.

A good-sized flower garden on turf extends some distance southward of the house, ample space being allowed between the beds, which in no case approach each other nearer than 10 feet, while they are each of not less than 6 or 8 square yards. The design of the whole was pleasing, and the beds were all filled with well-selected plants of the usual character. I noticed very good beds of *Geraniums* Lady Cullum, *Mrs. Pollock*, *Beauty of Calderdale*, and other ornamental-leaved varieties, as well as kinds cultivated for their flowers, *Lord Palmerston* being by no means the least important. The most striking bed was a circular one about 12 feet in diameter, composed entirely of *Centaurea c. nobilissima*, *Coleus Verchaffii*, and *Golden Pyrethrum*, the last-named being used as an edging. The rich colouring of the *Coleus* and *Centaurea* I have never seen exceeded. Other beds to the east of the house were of a more mixed character. A piece of interesting rockwork, forming a suitable screen between this part of the garden and the carriage entrance at the north-eastern corner, was well worthy of inspection, for the fragments of stone composing it are said to have been taken from an old religious edifice in the neighbourhood that had been demolished. Curved corbel, portions of clustered columns, and capitals with some foliage in an exceedingly good state of preservation attest the quality of the stone, which assuredly was not obtained in the neighbourhood. Relics like these give a charm to rockwork, which mere flints and petrified clay fail to do. There was likewise no lack of plants suitable for such a place. A very fine *Samaris* (*Rhus Cotinus*), at a short distance, in full flower attracted my attention; this very handsome shrub is not planted so much as it deserves to be, neither is the common *Berberis*, which in another part of the grounds was really beautiful.

Having described the flower garden and its appendages as adjoining the mansion on its southern, eastern, and north-eastern sides, I shall now proceed eastward, and as there are plenty of walks leading in that direction, I will follow the most southerly one, by which I soon come to the choice Conifers and shrubs for which this place is noted. Broad, well-kept gravel walks in easy graceful curves intersect the grounds in all directions, now and then approaching the boundary fence so as to afford a peep into the park, and at other parts skirting a mass of shrubbery on one side, with a thriving Conifer on the other, the intervening spaces being closely-shaven turf. Some of the shrubbery was necessarily dug ground; but even the marginal belts of these were in many places made accessible by neatly-formed turf walks curving through them. The centre of this extensive area, the ground originally level, had been broken into agreeably-shaped mounds in the most natural manner possible, and these, being planted with choice specimens, gave an ever-varying character to the scene.

The only attempt at formality was a bowling-green or croquet-ground forming a circle upwards of 100 feet in diameter, and sunk about 2½ feet below the surrounding level. Flights of steps descended to it on opposite sides with fairly-grown specimens of Irish Yews flanking the steps, and on one side a pretty summer-house occupied an elevated position overlooking the circle, the other being approached by an important walk. The quality of the turf forming the bottom and sides of this fine bowling-green showed that pains had been taken to secure a suitable depth of good soil for the grass to grow in, which is not always the case where extensive ground works are carried out. The undulations of the ground are, I believe, wholly artificial, for although a long period of dry weather had preceded my visit (early in August), and many meadows and grass fields had not thrown off their russety garb, there did not appear to be any place in the grounds more burnt up than was common everywhere, while the general aspect of the Pinuses and other shrubs was such as indicated the most robust health, with the exception of those which formed the belt or boundary to the north; but as these were for the most part common trees and shrubs planted for shelter, and, consequently, exposed to cold blasts, their weather-beaten appearance to windward is not to be wondered at. The valuable trees inside had sustained no

injury, and the past winter had done scarcely any damage to the collection at Kenfield.

I will now describe more particularly some of the contents of the pinetum. First on the list is the Wellingtonia, which here, as in most places, grows most luxuriantly, the tallest tree being 33 feet high, and the spread of its branches at bottom 26 feet. Here I may remark that the specimens of this tree at Kenfield (and there were many of 31, 28, 26, and 23 feet high and downwards), differed in outline from those met with in most places, where the general outline is a cone with the greatest diameter at 2 or 3 feet from the ground. This is the case with most of the Wellingtonias at Linton, while at Kenfield it was just the reverse; the trees there resembled a cone placed upon a sort of circular base of 2 feet in height or more, so that although the diameter of the tree above described was 26 feet at the bottom, it would not be more than 21 feet at 3 feet higher up, but from thence to the apex it formed as true a cone as could be desired. Both it and the other trees were densely clothed with branches covered with healthy foliage, and promised to vie with any indigenous tree. There was but one exception, a tree whose history I should be anxious to learn, as I expressed my suspicions it might go the same way as one at Linton did. However, all the others were pictures of beauty.

The Deodar was also well represented, and handsomely-clothed trees met the eye at almost every turning, and what is more, they seemed to retain the Deodar character, which is not the case with all the early-planted specimens of this tree, for many are gradually merging into the Lebanon form, losing alike the glaucous hue and pendant habit of the original Deodar. I believe these trees suffered but little, if any, either in 1860 or 1866, and many of them are assuming the dimensions of useful timber trees. A group of *Abies Menziesii*, occupying a rather prominent position in the grounds, promises to far eclipse the Common Spruce, which formed part of the outer belt; for, while the former were healthy and vigorous, and evidently 50 feet high, the latter showed unmistakable tokens of disease that will carry them off ere long if they be allowed to stand till then; this is the fate that has befallen them at Linton. The Spruce seems to luxuriate until about twenty years old, then it comes to a sort of standstill; a shabby, half-dead appearance carries it on some ten years more, and it then succumbs. Whether *Abies Morinda* and *A. Menziesii* be destined for a longer existence remains to be proved. Certain it is that *A. Menziesii* at Kenfield was all that could be wished. *A. Morinda*, though healthy, was less rapid in its growth; but there were some fine specimens of *Pinus Cembra*, which, I may remark, is not so much sought after as it deserves to be. Its upright, almost cylindrical form, contrasts strongly with the spreading habit of *Pinus excelsa*; there are good specimens of both at Kenfield, but the inclination of the latter to grow upwards was manifest there, as at other places; however, the density of the rich glaucous foliage, and its horse-mare-like texture, will ever render this tree a favourite. *Pinus ponderosa* was not so good as I have seen elsewhere; in fact, this is seldom met with in good form. The same, however, could not be said of *Pinus macrocarpa*, which was all that could be desired; and one that I would have called *P. Sabiniana* was likewise good. *Pinus Benthamiana* was promising, but had not had time to attain the dimensions of the others, while, perhaps the prince of all the *Pinus* family, *P. insignis*, was unsurpassed in beauty of form and healthiness; it had, however, suffered in the winter four years ago, but was a fine, handsome tree. *P. radiata* was said to have suffered more, and had since been destroyed. Most excellent specimens of *P. austriaca* were met with in various directions, some thriving better in the outer belt than the Spruce Fir. *P. Jeffreyana* and others were also well represented.

Of the *Picea* family there were several good specimens of *P. Pinsapo*, one large tree growing in the outer belt was fully exposed to the cutting north winds, which are so trying to all kinds of trees, and which last winter affected our native evergreens as well. It was, however, satisfactory to observe that this popular species had not suffered more than others, and certainly not so much as the Spruce; most of the specimens, however, showed a tendency to be dumpy, unwilling to grow upwards, which is a fault with some others of the *Pinus* tribe. *Picea cephalonica* was better, but this also has in most cases a disposition to spread laterally, still its beautiful green tint will always entitle it to a place. The prince of this section, however, is undoubtedly *P. Nordmanniana*, of which a fine specimen 26 feet high, and of symmetrical growth, occupied a prominent position, and well deserved it. *Picea nobilis* was also a fine

tree, but less fortunate in its site; it had, like others of its class elsewhere, borne fruit a year or two previously, but its upright growth gave promise of maintaining that superiority amongst its brethren which its name implies. Of the same glaucous hue was a remarkably fine tree of *P. magnifica*, the height of which I unfortunately omitted to ascertain. Promising specimens of *Picea Lowii*, *lasiocarpa*, and *Parsonsi*, perhaps all the same species, were also noticeable. *P. lasiocarpa* has, perhaps, the longest foliage, which is also awl-shaped, and at Kenfield it promised to become a tree of some magnitude, its growth being rapid, and its form good. I found here, as at many other places, that *P. Webbiana* had succumbed to some of the hard winters of late years. *P. amabilis* and *grandis*, also thought to be synonymous, were likewise good, and a very promising plant of *P. bracteata* appears likely to be amongst the first of its series in this country, and to all appearance will become a favourite. I believe it has not been long introduced, but still sufficiently so to establish its hardiness.

Near some of the Conifers just named were excellent specimens of *Cryptomeria japonica* and *Lobbii*, the former being about 30 feet high. *C. elegans* was also in a promising condition, being upwards of 7 feet in height, while *C. Lobbii* rivalled *C. japonica* in height, and still more in luxuriance, but as the difference between it and *C. japonica* is so slight, perhaps both may merge in one hereafter. *C. elegans*, however, is one of the handsomest Conifers of recent introduction. Of *Cephalotaxus Fortunei* there were both male and female plants, the two differing widely in appearance, but they may only be regarded as shrubs of moderate growth, or even lower than that. Not so, however, the Japan *Retinospora*, of which good specimens of *squarrosa*, *obtusa*, and *pisifera*, stood out conspicuously, the last named promising to become a good-sized tree, while the silvery graceful appearance of *R. squarrosa* contrasted well with plants of a deeper hue. *R. leptoclada* also promises to rival the Irish Yew in form and size, although differing widely from it in foliage. Some variegated forms of *Retinospora* were also pointed out, but their liability to return to the original condition impairs their interest.

I believe all the dwarf forms of the *Pinus* family were well represented. By far the finest specimen I have seen of *Sciadopitys verticillata*, the Umbrella Pine, was shown me, as well as *Abies Kumpferi*. The specimens of *Abies clauseniana*, *Pinus pygmaea*, and others, contrasted strongly with the upright form of *Thuja Lobbii* and *Menziesii*, each of which was upwards of 20 feet high. *Thuja gigantea* was here, as elsewhere, less robust, and somehow is hardly deserving the name it bears, as its growth is slower, its form cylindrical, and the head rounded rather than conical. *Thujaopsis borealis*, however, was flourishing, and equalled *T. Lobbii* in sturdiness of growth. One or two good plants of *T. dolabrata* were also pointed out, as well as the more recently-introduced *T. latevirens*, but it was hardly large enough to give an opinion upon, as were also some other varieties or species of *Thuja*, and possibly several of those which now present a marked difference may in time merge into others, and the same with *Juniperus* and *Cupressus*. Conspicuous amongst the latter were *C. macrocarpa*, 30 feet high; *C. funebris*, more inclined to spread than grow upwards; and *C. Lawsoniana*, by no means so satisfactory here as I have met with it elsewhere, although plentifully planted. Other species, as *Cupressus McNabiana*, and *majestica*, were good.

The *Juniper* family were also in force, and, as I have noticed elsewhere, their inclination to fruit seemed to check their growth, but I confess my recollection of this interesting section is not sufficiently clear to deserve recording. One or two excellent plants of *Taxodium sempervirens* ought not to be passed over, as I do not think better specimens can be found. One of these in the interior of the grounds had not received any injury during the past winter, yet another exposed to the north winds had suffered; both were high fine timber-looking trees. *Araucaria imbricata* was hardly so much at home, but it was, nevertheless, upwards of 30 feet high. *Liocedrus chilensis* was as good and as promising as it usually is, while one of the most conspicuous of all *Pineas* in many places, *Abies Douglasii*, fell short of what might be expected of it. Although there was a good full-sized tree of it, yet the proper robust character and dense deep green hue were wanting, proving that the soil did not exactly suit it. The too great abundance of calcareous matter, however useful it may be for the welfare of a number of plants, is inimical to the well-being of the Douglas Fir. There was, however, a very fair specimen of the deciduous *Cypress*; and though the equally interesting *Salisburia adiantifolia* was much

smaller, it was a good specimen of its kind. The more recent introductions were also duly represented, for Mr. Thomson, the proprietor, who for thirty years and more has been an ardent admirer of Conifers, and has during that time added to his collection all that were worth having, still secures anything new that may appear, and the collection lacks but little to make it unique. Other shrubs also were not forgotten, for I noticed a border containing an excellent collection of Hollies, and now and then the whole was enlivened by the beautiful bloom of *Althæa frutex*, Virginian Sumach, and other gems of the shrubbery.

I have said the pinetum, or pleasure-ground enclosure, was surrounded by the park; it ought also to be mentioned that the former is so large as also to enclose within it—nay, almost conceal from view, the kitchen garden, where some good vegetables are growing in spite of the dry weather, and the Peach trees on the walls were loaded almost too heavily. Outside the kitchen garden, but still within the dressed grounds, there was a group of plant houses and pits, the latter partly hidden from the pleasure grounds by a fernery. They were all in excellent order, but the space already occupied by the description of the pinetum forbids my entering into details here. I must not, however, omit to mention a very promising young orchard two or three acres in extent, where there was as fine a lot of Plum, Apple, and Pear trees well loaded with fruit as can be met with anywhere. The Pear and Apple trees were mostly pyramid-trained, and planted about 8 feet apart. The Plum trees were grown as standards, and were heavily laden with fruit.

This plantation is outside of the park, and on the way to it I passed a Horse Chestnut tree in which one branch was growing into another, forming a natural graft in a manner I had never before seen. The tree was of good size, and at 12 feet or so from the ground a limb, about as thick as a man's body, extended from the trunk in a diagonal direction at an angle of upwards of 40°, and about 3 feet higher up the bole another limb, much smaller than the last, projected at an angle of about 25° or less, so that at some 10 feet or so from the bole the two limbs crossed and united, the junction presenting none of the swellings or excrescences so common in grafting, the bark being as smooth and uniform as on any part of the tree. A short distance from the junction the limb broke out into branches. The appearance was that of a well-constructed brace, and no doubt the graft acted as such; but although I have often enough seen natural grafting in Beech and other trees, I never saw anything to equal this, and Mr. Thomson, who takes especial notice of trees and their various peculiarities, pointed it out to me as deserving of notice.

The park is well studded over with groups of trees and single specimens, especially Horse Chestnuts and Thorns, with some good Oaks and Ashes. Mr. Thomson, who is also a great admirer of the common Yew and Scotch Fir, pointed out a piece of woodland on the crest of one of the distant hills in which were some good specimens of the English Yew that he made an especial point of preserving. The wild Cherry, or *Gascogiu*, he also admired, as well for its beauty in autumn when its foliage dies off crimson, as in spring when its snow-white blossoms give such a charm to woodland scenery. I believe he has planted this tree extensively in places where its beauties will be seen to advantage; and in a district where cultivators, as a rule, have denuded it of all its beauties, an admirer of Nature's noblest productions like Mr. Thomson must be looked on as a benefactor.—J. ROBINSON.

[Our readers will remember that some time ago Mr. Covey, at Kenfield, replied through our columns to an inquiry made about the height of Wellingtonias, and we hope others having fine trees of this species will also favour us with the dimensions, as well the soil and situation in which the trees are growing; for although the Wellingtonia seems to accommodate itself to almost every place, there is no doubt certain soils suit it better than others.—EDS.]

ORCHARD-HOUSE PRODUCE.

I SEND an account of this year's produce. I have gathered and sent to table 850 Peaches and Nectarines, and 100 really good well-finished bunches of Grapes out of the orchard house, of which I wrote some time ago. The Peaches averaged 9 inches in circumference, and the Nectarines 8 inches. The largest Peach measured 11½ inches in circumference, and weighed 11½ ozs. I think even the most sceptical (no one can

be more so than I was three years ago), must own that orchard houses are really useful, profitable, and highly ornamental. They are more especially adapted for the villa residences near London, where a Peach wall is out of the question, but orchard houses might easily be erected, and with them the crop is almost a certainty, at least with anything like good management.

I find the syringe my most useful friend, having had no symptoms of insects, and the trees rejoice in frequent applications of house sewage made lukewarm by diluting it with hot water.—J. H. DAVIS, *Hazelwood, Upper Norwood.*

NEW VERBENAS AND GOLDEN FEATHER PYRETHRUM FOR BEDDING.

"AYRSHIRE GARDENER" condemns the new and improved Verbenas as being utterly incapable of enduring any hardship. I do not know any of the old sorts of Verbenas which will endure hardships such as the Zonal Geraniums have to undergo. If a Verbena will not stand dryness at the root, and cold and want of light during the winter, it is condemned. Small half-rooted plants are pricked out from cutting pots into beds in May and June, and expected to grow and flourish. Daily waterings are as sure to injure these plants as dry-and-dust treatment. A watering once or twice a-week, with a little liquid manure each time, is enough for any Verbena; and every plant ought to be well rooted and established in 4-inch pots before bedding-out, and the foliage healthy, free of thrips, red spider, and green fly. If only a little more pains were devoted to Verbenas there would not be such an outcry against them.

Contrary, again, to "AYRSHIRE GARDENER'S" experience, I can see Golden Feather Pyrethrum as good now as ever. Instead of waiting for the flowers to open and cover the plants, if the flower-spikes are cut closely down at the first appearance of a head of bloom, the plants will continue dwarf and bushy to the last. Though the heat blanches the colour, it is, however, quite as golden now, where this treatment is pursued, as Crystal Palace Gem or Cloth of Gold Geranium.—AN AMATEUR.

IN "AYRSHIRE GARDENER'S" interesting notes on bedding plants in your last issue, I was sorry to learn of his failure with, and condemnation of the above subject as a summer bedding-out plant, inasmuch as here it has proved all that could be desired. If I may judge by last season's experience of its attributes, I will venture to say it will continue so until the end of the season, with no more trouble bestowed upon it than is accorded to the various other occupants of the parterre, with their peggings-down, picking off of seed heads, &c., the only attention required by the Golden Feather being by occasional picking off of the flowers as they appear.

I may add, we have Golden Feather Pyrethrum here doing duty in charming contrast with large beds of *Stella Nosegay* Geranium, to which it affords an effective margin, the greenish yellow of the latter affording a pleasing harmony with the scarlet crimson inflorescence of the latter. And as an edging to such as *Coleus Verschaffeltii*, *Iresine Herbstii*, *Centaurea ragusina*, blue *Lobelia*, *Verbena Purple King*, &c., I have also found it to be most effective, proving in some instances more satisfactory than *Cloth of Gold* Geraniums will only flourish in a comparatively rich and moist soil, whereas the Golden Feather is not so particular as to the condition of the medium in which it grows, unless dust dry. I trust, with due respect to "AYRSHIRE GARDENER'S" opinion, that your readers who have not as yet patronised the Golden Feather Pyrethrum as a summer bedding plant may not be deterred from giving it a trial next season, as I am confident that with due attention to picking off the flower heads as they appear, and to keeping the roots in a growing state by an ordinary amount of moisture, success will be thereby insured.—WILLIAM GARDNER, *Gardener, Lower Eaton Park, Stratford-on-Avon.*

BEDDING PLANTS IN 1870.

(Continued from page 130.)

IN continuing my remarks on bedding plants this season I will now proceed to the Zonal Pelargoniums, and will take the flowering section first—that is to say, those grown for the beauty of their flowers, and not of their foliage, and in which

the foliage is only a secondary consideration, though it must be always borne in mind that coarse large leaves, or straggling footstalks to the leaves, are a great drawback to the merit of a Geranium, however good the flowers may be.

It is difficult to classify Geraniums now by their colours, as there is almost every gradation of shade in reds, from a dark crimson to an orange scarlet, and so on; but I will endeavour to take the different colours in order as nearly as I can, beginning with the crimsons and crimson scarlets.

Of these, the best two with me have been Waltham Seedling and Bayard. The first is a trifle the darker, and the latter the brighter; they are quite distinct in habit, and ought both to be grown. Bayard, now that I have given it a season's trial, is certainly the best crimson scarlet I have grown in beds, and I must confess myself mistaken as to the size of the truss, which in some notes I sent you in the spring I said I thought would not be so large as Waltham Seedling, but it is, on the contrary, larger. It is very free-blooming, and the trusses last well; its only fault is that the stalks are hardly strong enough for the heads and fall about, and in this respect Waltham Seedling is better, as the flower stalks are short and stiff, and show every head. Good as Bayard is, Mr. Pearson has better varieties in store, which he has not yet sent out, especially some seedlings of this year, which I have twice carefully looked over, and of which I will send some notes at a future time. I think, also, Douglas Pearson, Thomas Speed, Duke of Devonshire, William Thomson, and some others he sent out this spring, are quite as good, if not better.

Other crimsons I have tried this year have been International, Eclat, Lord Palmerston, and Le Grand. International does not flower freely enough. Eclat, though it has a very fine truss, is too long in the flower stalk, and too coarse in the foliage. Le Grand is at times very good, but the flowers do not stand sun well, and it runs to seed. A very promising variety which I had in a trial bed is Stanstead Rival (Downie, Laird, & Laing); it is a brighter and lighter-coloured crimson than those before mentioned, a very fine truss, and free-blooming.

Two other very good sorts of dark crimson I have not grown myself, but seen elsewhere, are Vesta and Glory of Waltham. The first was highly spoken of at Chiswick last year, and I have seen it very good this; very dwarf and compact. The latter I saw very good at Studley Royal (Earl de Grey and Ripon's), under the care of Mr. Clark, the rich dark green of the foliage harmonising very well with the colour of the flower. Lord Palmerston is so well known I need not make any remarks on it. It is an old favourite, and I do not like to discard it; it is exceedingly good as a late bloomer. It is, however, far surpassed by Duchess of Sutherland, though they are not of exactly the same shade of colour, as Duchess of Sutherland is brighter, and it is a first-class dry-weather plant. It has been in full beauty now with me ever since I came back (21st of June), and is as full of fresh flower stems now as ever. Something of the same shade of colour is Lady Kirkland, another of Messrs. Downie, Laird, & Laing's seedlings, and which was kindly sent me on trial by Mr. Charles Turner. It has the largest head of bloom I have almost ever seen on a Nosegay Geranium.

I will take the scarlet and orange scarlet sections next, as Cybister, Lady C. Grosvenor, Multiflora, Grand Duke, William Underwood, and Rival.

Cybister has again been very good, but rather too leggy in habit; it, however, does not run to seed in dry weather. Lady Constance Grosvenor has been far better with me this year than last, and has bloomed much more freely; the colour is undeniably good, brighter than Cybister, and the habit more dwarf and spreading; its only fault is that the flower stalks are not strong enough for the truss, and it is, consequently, much better in dry weather than wet. Multiflora has not been so good as I expected; it has, however, a very nice dwarf habit, but the flower trusses are not large enough individually, though they are very freely produced; but it is of a very rich colour, and the individual blooms are large. Grand Duke is an orange scarlet, with an immense truss, good footstalk, and vigorous habit; of the same sort of growth as Le Grand, but a freer bloomer, and would be a splendid sort for a large bed or a ribbon border. It might be coarse in wet weather, but is certainly very good in dry.

William Underwood is the best red Zonal with me, but like all of the Zonals I have ever tried, it does not branch freely. I am gradually discarding all the Zonals (as I said in the spring), for this reason. I have tried a great many, as Clipper, Dr. Lindley, Herald of Spring, Miss Martin, &c., and always

find, that though by pinching-in closely in the spring, and putting them out as bushy plants, they make good beds at first, yet unless planted very thinly they never branch, and the same number of stems almost will be found on them at the end of nine or ten weeks as they had when planted out; moreover, although the individual flowers are more circular and of a better form, yet it is seldom they make a very large truss, and now that the Nosegay section are so much improved by crossing, some of the blooms of the Nosegays are almost as good in shape as the old Zonals with double, or, I might say, three or four times the amount of truss.

Of all the Zonals, Rival has, to my mind, the finest-shaped flower, but though I shall try it another year, I do not think it will stand wind or rain. Glow is another very fine scarlet, but the centre of the truss is too crowded, owing to the stalk of the individual flowers being too short.

Among the orange scarlets of the Hybrid Nosegay section, two that were sent out this year by Downie, Laird, & Laing are very good, Lady Hawley and Sunlight. Of the two, I prefer Lady Hawley; it has an immense truss with a good stiff footstalk, which holds the truss erect, the habit is also good, and I shall be much mistaken if it do not prove a great acquisition. Kentish Fire and Masterpiece were planted out too late in my trial beds this year to give them a fair trial, as they had been too long in small pots; both, however, I think are good varieties.

I hardly know whether to class Godfrey among the orange scarlets or the next class I shall name, the Reds. It is very free-flowering, but the footstalks are too long; still, it is a good variety.

I will defer my remarks on the other colours till another week. I only wish, in conclusion, to ask some of those who are now cutting their beds of Geraniums to pieces to get cuttings to try the plan of striking them later, when they finally have to pull the garden to pieces in the autumn, putting them in small pots, five or six cuttings in a 4 inch pot, and placing them on shelves close to the glass in vineries or elsewhere. It is a great mistake to think that plants are hardened by being kept cold during the winter; and cuttings struck in this way, and kept growing all the winter through, soon overtake cuttings that are taken off now, struck in the open border, and then potted off for winter; and still more will they surpass those that are pricked close together in boxes or pans to be struck in the open air now, and stored in these pans all the winter in cold frames. Warmth during winter will not make Geraniums tender, so long as they have plenty of light and are near the glass.

The earliest and best Geraniums I had this year were some I put into the stove in November to grow on for cuttings; and the cuttings I struck in the stove in January and forced on were more forward and better plants than those struck in the open air in August, were earlier in bloom, and have lasted quite as long—in fact, I cannot in any one instance see that they have less bloom now than those which were more backward in coming into flower. They were removed from the stove into a light double-span house the third week in March, and were not moved out of this house till they were taken out to be planted in May. I tried this with several sorts—Bayard, Grand Duke, Eclat, Godfrey, Blue Bell, Lady Constance Grosvenor, Violet Hill, Ne Plus Ultra, &c. Of course it would not do in stoves where climbers were growing over the roof, or where shade is used for ornamental-foliaged plants, but where Geraniums can have plenty of light and are not too far from the glass there need be no fear of making them tender from too much warmth during the winter. The best use for cold frames is not to winter plants in, but to put them into in spring, using vineries and other houses during winter.—C. P. PEACH, *Appleton-le-Street*.

(To be continued.)

EXPORTING CUTTINGS OF FRUIT TREES TO AUSTRALIA.—In the form of cuttings, all the new varieties of fruit trees may be introduced with the certainty of success. The importance of this will strike all who have experienced the losses and disappointment attending the importation of the trees. The introduction of new varieties is by this means rendered a very simple and inexpensive matter. A case of 6 cubic feet capacity will contain some thousands of cuttings, the trees of which would require a space equal to many hundreds of tons measurement. Another advantage with the cuttings is, that the case may be hermetically sealed and stowed away like ordinary merchandise; whereas, special instructions as to care (which

is seldom exercised) have to be given as to the stowage of the cases containing trees.—(Report of the Horticultural Society of Victoria)

NOTES AND GLEANINGS.

INTERNATIONAL EXHIBITION OF 1871.—We are requested by Her Majesty's Commissioners to state that there is no foundation for the rumour that the International Exhibition appointed for 1871 is to be postponed by reason of the war. The first of the series of Annual International Exhibitions of selected works of fine and industrial art and scientific inventions will take place next year, as already announced.

— Mr. W. Taylor, gardener to J. Yates, Esq., Lunderdale House, Highgate, informs us there is a fine specimen of the *LITTEA JUNCEA* now in flower at that place. The spike is 15 feet in height.

— We are requested by the Council of the Royal Horticultural Society to state, that in consequence of the works now in progress for the Annual International Exhibitions of next and following years, the ROYAL HORTICULTURAL SOCIETY'S GARDENS at SOUTH KENSINGTON, will not be open free to the public on the 26th of August, the anniversary of the late Prince Consort's birthday.

WORK FOR THE WEEK.

KITCHEN GARDEN.

EVERY attention should at this period be given to the high cultivation of winter crops. Where sufficient labour is provided at all times, not a weed should be allowed to show its head. When, unfortunately, weeds have done so, the use of the spade is recommended instead of the hoe. Besides, it is as economical in the first instance, excepting in very hot and dry weather like the present, for, unless the hoeing be succeeded by a raking, the hoeing will in general have little effect. Moreover, the benefits of exposing the soil to the air are very considerable, especially in ciferate soils, such as those of most of our kitchen gardens. All the *Cabbage* tribe, from the Early York Cabbage up to the Cauliflower, should be soiled up the stem as high as possible. When such crops are on poor land a dressing of guano or fowls' dung at this period would be of eminent service. It might be introduced as in South America in the cultivation of Tobacco, Indian Corn, &c.—viz., by hand around the stems of the plants. It is advisable to mix it with four times its bulk of dry old tan, sawdust, charcoal dust, or anything which will duly separate its particles. This process should, of course, precede the soiling. Where plants of this family are liable to "club" this course will be found of much service, as they frequently depend for their existence on a few late-made roots. Let a good breadth of *Coleworts* be planted out in well-prepared ground; as before observed, the Onion beds will be available. Let the winter *Cauliflowers* be sown directly. Late plantings of *Endive* must be made forthwith. The plants will be eligible to move with balls of earth into frames in November. The soil must be very rich. This is an excellent time to make a sowing of the Brown or Bath Cos and Hammersmith *Lettuces* to remain where sown through the winter. The beds should be elevated considerably, the higher the better, and the seed scattered broadcast rather thinly. A rich border should now be prepared, and planted with the Bath or Brown Cos *Lettuce*; these will carry on a supply from the open ground until Christmas, if protected. *Leeks* are most useful in a variety of ways, and should now be soiled up after the manner of Broccoli; a dressing of guano may be introduced previously, if the soil is not sufficiently rich. The old *Strawberry* rows should now have attention. The leaves of the runners will shade the principal leaves of the mother plant, and therefore some gardeners mow down the runners in order to throw sunlight on the leaves left. Mowing down the old plants is an absurd process which some still adhere to. If the *Tomatoes* are over-luxuriant, cut away a portion of their roots.

FRUIT GARDEN.

Go over the fruit trees and stop about half the shoots, beginning, of course, with the strongest, for a general stopping at this time would probably be of little further service than to induce the production of a mass of useless spray; whereas stopping the stronger shoots, or those which incline to grossness, will direct the sap into the weaker ones, which will be strengthened, while the buds on the shoots that have been stopped will become full and plump without starting into growth. The only effectual method, however, of curing a gross habit of

growth, when it occurs in ordinary seasons, is root-pruning, or keeping the roots within proper limits by means of shallow well-drained borders; and should it be found that the shoots after stopping incline to start into growth, it will be advisable as soon as the fruit is gathered to open a trench at a moderate distance from the stem of the tree, and to cut the stronger roots. This will be of the greatest service in checking growth, and will probably do more towards securing ripe wood than anything else that could be adopted.

FLOWER GARDEN.

In many neighbourhoods bedding plants are only just coming into full beauty. Go over them frequently, and without loss of time remedy any defects that may be perceptible, for the flower garden this year will be enjoyed but for a comparatively short season; and now that the plants are in beauty every means should be used to render them as enjoyable as possible, by maintaining the most perfect order and neatness. Where the stock is clean and growing vigorously this will involve considerable labour, and it will be necessary to look over the beds frequently, pegging down where necessary, removing decayed flowers, and cutting back such of the shoots as may incline to encroach upon the edging of the beds. Keep herbaceous plants neatly tied up, and cut off the lower-stems of any that are becoming unsightly. Take advantage of every leisure hour to put in cuttings, and use every possible dispatch with this work until there be in a fair way for rooting a good stock of such plants as are known to be difficult to winter except as well-established plants. Make gravel walks perfectly clean and smooth by weeding, sweeping, and rolling, as may be necessary, and keep climbers on walls within due limits. Propagate *Hollyhocks* by cuttings. Mark good seedlings, digging up all single and semi-double varieties. Take off the tops of seedling spikes, if not already done; it throws strength into the remaining flowers, and encourages the formation and growth of the seed. A few *Crocuses*, *Snowdrops*, &c., may be planted soon to obtain an early bloom.

GREENHOUSE AND CONSERVATORY.

Continue to look over climbers, borders, &c. Large specimens which had been removed out of doors to give room, will soon require to be replaced in these structures; indeed, the whole of September will occasionally call for business of this kind. The earth worm is a greater enemy to pot plants in general than low temperature. Look well after late-flowering plants. The late *Heliotropes*, *Scarlet Pelargoniums*, *Petunias*, &c., if preceded with as recommended weeks since, will now be somewhat potbound, and will in that state, with the application of weak liquid manure, produce abundance of blossom on a light shelf until the beginning of December. *Lachenalias* should be instantly repotted, and the *Persian Cyclamens*, if planted out in spring, will now be fine bushy plants full of young leaves. They must be taken up forthwith with all the soil possible, potted carefully, and placed in a cold frame or propagating house; a bottom heat of 75° would be an advantage, with a very moderate atmospheric temperature. After three weeks of this treatment they may be introduced to the greenhouse, where they will produce their fragrant blossoms in abundance from November until April.

STOVE.

Many of the earliest growths of *Orchids* showing signs of ripeness in the leaf and plump pseudo-bulbs, may be removed forthwith from the excitement of the growing house. Any situation in the light where a temperature averaging 60° night and day can be guaranteed, will suit them well. A very moderate amount of atmospheric moisture will suffice.

COLD PITS.

Young stock in cold pits intended to flower next season, should be exposed to the midday sun, in order to ripen the wood, taking care not to do this so rashly as to injure the foliage. This, however, will only be proper in the case of such things as have already made plenty of young wood, but it is advisable after this season to be anticipating the approach of winter, and to use every means to forward the growth of valuable hardwooded plants in order to have it somewhat firm and able to resist damp, and that as soon as possible.—W. KEANE.

DOINGS OF THE LAST WEEK.

KITCHEN GARDEN.

Owing to the dryness most work was held over, except a free hoeing of the surface, and digging and trenching all vacant

ground, to be ready for planting when rain comes, or we can obtain water. Frequent hoeing, even though there be few or no weeds, greatly helps to prevent the escape of what moisture is left in the soil. In ground which had been rather heavily cropped, we found scarcely a trace of moisture at the depth of 18 inches. Planting, without being able to water, was out of the question. We find all round here that Potatoes are beginning to grow again; the sooner they are taken up the better, as the tubers become hard and stringy when fresh ones are allowed to come from them.

FRUIT GARDEN.

Many trees, as Peaches on walls, are so suffering from these dry bright days that we would have soaked the roots if we could have done so. We may have to resort to some mode of shading to preserve the crop, but unless a change come soon all fruit will be smaller than usual. Trees in houses, whether in pots or otherwise, have been greatly assisted by slightly shading the glass with whitened water. We have been forced to apply it to almost every house, to enable us to do with as little moisture as possible. We have used gauze netting for ventilators, in some cases removing the ventilators—to keep wasps and flies out, but now, after doing this, few wasps are to be seen again, though for three or four days they were in myriads. Melons, as a rule, have been good this season, being none the worse, perhaps, of having had less of the syringe than usual. It must be pretty well put aside when water has to be carried from three to four miles.

ORNAMENTAL DEPARTMENT.

With a little picking flower beds and borders still look very well in places where Peas have been burnt up as if with a hot blast from a furnace, and even Cabbages blue-coloured and hard. With rain to refresh the grass, the flower garden will stand out the season. We are doubtful as to the results with another ten days of this weather. The lawns have neither been mown nor machined for a long time, except in the case of little pieces here and there, that were too long for the daisy knife to manage. It was altogether too dry for Daisies to show themselves, but Bents, Plantains, and the pretty yellow Lotus corniculatus would appear, and the knife soon settled them.

Walks.—These have needed little care this season, but we were apprehensive that they might trouble us in the autumn if it should prove damp and drizzly, and then walks are difficult to clean. We have had them all put in good order, which we generally do rather earlier in the season. The sides were neatly cut, the walks hard-swept, and then a slight sprinkling of salt was thrown all over them, followed by enough of fine sandy gravel passed through a half-inch sieve; the back of a rake was passed over this, and then they were rolled when dry. As soon as rain enough comes to wet the walks they will be swept to take out all inequalities, and when well rolled will give little more trouble through the autumn and winter. By adopting this plan we rarely break the surface of these walks, and in general they are dry, smooth, and pleasant to walk on in all weathers. The slight sprinkling of hard sandy gravel causes them to look bright and fresh, especially after they have been rolled when damp. But for that sprinkling we would not salt walks so late, as they would be apt to be damp, and even to adhere to the feet in winter. The slight sprinkling of sand above the salt neutralises that tendency, whilst it also insures the salt being equally absorbed instead of being washed to the sides. Salt when merely scattered over the surface acts most effectually when so scattered in dry weather. It is also the easiest way to apply it, and the salt is quite as effectual as when presented in a strong solution of hot or cold water, which we could not contemplate. Even in dry weather the salt will disappear in a few days. It is no ornament to the walks, however, so long as it remains white, and it does not do to traverse walks and lawns alternately. The slight covering of sand remedies both inconveniences; it also ensures a dry surface instead of a clammy one in winter.

Now is a good time to sow Mignonette for winter and spring blooming, Stocks for spring blooming, and many hardy annuals, &c., to be protected a little in winter. Such as Schizanthus, Collinsia, Clarkia, Nemophila, as well as Wallflowers, potted, come in useful for cut flowers in spring, and good pots of them in full bloom look very well. A fine specimen of Collinsia bicolor might grace any drawing-room.

Pinks, Cloves, Carnations, and Picotees.—We are rather late with cuttings of these this season. The better kinds of Carnations and Picotees do best layered if suitable "grass" can be had, but they strike freely enough as cuttings, and a cutting can often be obtained when a layer could not be made without

some trouble. Pinks and Cloves of all kinds may be struck now, either under hand-lights or in a frame, if just a little mild bottom heat be given them. They will do planted out in fresh sandy soil, with a little sand at the top. If at all doubtful, the best Cloves and Carnations might as well be put round the sides of a small well-drained pot, and the pot be plunged, for then there is the advantage that you can renew the mild heat if it be wanted. Where space in a frame can be spared, this plan involves far less trouble on the whole than layering.

No kind of cuttings can be more quickly made. It is seldom that a knife need touch them. We think that years ago we detailed the simple process, which also has the advantage of mutilating to the least possible extent the old plant. Proceed thus:—Take hold of the shoot that you are to take the cutting from in your left hand, to keep it firm and steady, and take the point of the shoot in your right hand near to the second joint, give a sharp pull, and out it comes at the joint cleaner and more neatly than ever you could cut it with a knife after much stripping of leaves. Sometimes a little film may be left at one side, and that should be removed with a clean knife. In general nothing whatever is wanted, but the cutting or piping will be in the best possible condition for planting. A clever lad will slip out these cuttings as quickly as one can write a letter in one of these words.

Propagating Bedding Plants.—This must often depend on circumstances. Where there are reserve gardens for cut flowers, it may be done early. We have not such a garden, and there is always a little reluctance to spoil the contour of a bed or border, which taking many cuttings from a small place is sure to do. On the same principle the question may be settled as to the advisability of taking large or small cuttings. Had we plenty of room for wintering, and other matters suitable, we would take off strong cuttings of Scarlet Geraniums, insert them at once in small pots, and winter them in these pots. We might save time at first by planting the cuttings in an open border, and then lifting and potting, but ultimately we should gain but little, and the plants struck in a border are likely to be more succulent than those struck in a pot. One advantage of large cuttings is, that provided some of the larger leaves are removed, they need little or no protection or shading, as there will be enough of moisture stored up in the cuttings to enable them to bear sun and air before roots are formed. Even light drooping does them little harm. We seldom, however, for reasons indicated, take large cuttings, and thus we break as little as possible the outline of the bed, and save a great many in little room in winter, but we give them a little help in spring. Some gentlemen looking at large plants in vigorous growth in beds would scarcely credit that these plants were cuttings from 1½ to 2½ inches in length last September. These we generally place thickly in pots and shallow boxes, preferring the latter, leaving them about 1½ inch apart. The cuttings when obtainable are chiefly short, stubby side shoots slipped off close to the scouter stems, and most of these cuttings, therefore, will have the point or axis of growth. With such small cuttings, especially of the variegated Geraniums, it is well to protect them at first with old sashes, mats, or calico, the last the best, until the base of the cuttings swell so as to be ready to protrude roots.

With such plants as Verbenas, Heliotropes, Pentstemons, Salvias, Iresines, Coleus, &c., we prefer the small side sheets as cuttings, and such plants as Verbenas we put in more closely than Geraniums, seldom giving them more room until spring, when they are cropped for more cuttings, and encouraged with weak manure-waterings. The most of these plants are the better of being placed under glass, kept close during sunshine, and, if near the glass, shaded. If from 20 to 24 inches from the glass they will not need shading if given a skiff from the syringe about midday. We like to get these at least partly in before we begin with Geraniums, as they always succeed best when struck cool—that is, in a cold pit or frame without any artificial heat. The heat of the sun during the day we neutralise by keeping them cool at night—by giving air then, the best of all securities against damping. From 6 or 7 p.m. to 7 or 8 a.m. the young cuttings will bear a little air well, and be all the more robust in consequence.

We frequently use small pots, as 60's and 48's, for Verbenas, and sometimes shift into larger pots when the cuttings are well struck, but we prefer wooden boxes averaging 3 inches deep for our main stores, and just of the size we can find wood to suit, but averaging a foot in width and 2½ to 3 feet in length. The pots are generally filled from a fourth to a third with drainage,

then rough nodules of fresh loam over the drainage, then finer light soil, followed by a surfacing of lighter still, with more sand. The boxes need no drainage. They are chiefly made in rough weather from rough packing boxes, or boards which have been merely sawn, not planed. The extra waterings, therefore, can escape quite fast enough at the sides. These boxes, if old, are well cleaned before being used, and old and new alike are well painted with fresh limewash. This is a great preservative against fungi, which otherwise are apt to attack rough wood in damp places. These boxes are easily moved from place to place, a matter of importance where much moving is to be done. A thin layer of rough nodules of the turfy soil is spread over the bottom of the box, very likely with the addition of a little charcoal, then a finer layer of sandy loam, followed by one finer still, with more sand in it, and a little charcoal dust at the surface, the whole pressed down moderately firm. If at all moist, we put in the cuttings before watering, and then the watering settles the soil firmly about them.

From years of experience and observation we can safely state that the health and robustness of the cuttings and young plants depend more on the freshness of the soil than on its richness. It is safer to aid the roots with weak manure-waterings than by mixing crude manure with the soil. We have seen fine heaps for such cuttings made from old Cucumber beds, decayed leaves, dung, and plenty of sand, but the cuttings often turned out very unsatisfactorily. We prefer sweet fresh sandy loam, and made so if it cannot be found naturally. This we pass through sieves to obtain the requisite qualities—rough, but not in pieces much larger than beans for the bottom, lighter and finer above, and the top layer finest of all. This takes very little more time. All half-rotten leaves or dung for the bottom we discard, as they are the fruitful source of fungi and decay at the roots. We do not object to a little sweet, thoroughly decayed, well-aired leaf mould, finely sifted, mixed with the upper layers, along with a little fine charcoal dust, but if the leaf mould be not sweet and well aired beforehand, we would rather be without it altogether. We have known hundreds and thousands of struck cuttings ruined, because the propagator placed a good handful of half-decayed tree leaves over the drainage. Of course, they would often do no harm, but very frequently they become dangerous as a regular feeding ground for fungi.—R. F.

TRADE CATALOGUES RECEIVED.

F. and A. Dickson & Sons, 106, Eastgate Street, and Upton Nurseries, Chester.—*Catalogue of Dutch Flower Roots, &c.*

W. Cutbush & Son, Highgate.—*Bulb Catalogue for 1870.*

H. Curtis & Co., Devon Rosery, Torquay.—*Descriptive Catalogue of Selected Roses.*

Dick Radcliffe & Co., 129, High Holborn, London, W.C.—*Autumn Catalogue of Dutch Bulbs, &c.*

Downie, Laird, & Laing, Stanstead Park, Forest Hill, London, and 17, South Frederick Street, Edinburgh.—*Descriptive Catalogue of Dutch Flower Roots.*

TO CORRESPONDENTS.

* * * We request that no one will write privately to any of the correspondents of the "Journal of Horticulture, Cottage Gardener, and Country Gentleman." By doing so they are subjected to unjustifiable trouble and expense. All communications should therefore be addressed *solely* to *The Editors of the Journal of Horticulture, &c., 171, Fleet Street, London, E.C.*

We also request that correspondents will not mix up on the same sheet questions relating to Gardening and those on Poultry and Bee subjects, if they expect to get them answered promptly and conveniently, but write them on separate communications. Also never to send more than two or three questions at once.

N.B.—Many questions must remain unanswered until next week.

Books (*Constant Reader*).—There is no such book. If you read what Mr. Moore said at Oxford, which is reported in last week's Journal, and Dr. Hogg's address, which you will find at page 84, you will meet with all you require to know. (*Henry*).—A new and very much enlarged edition of the "Fruit Manual" is now in preparation, but it will not be published until a few months hence.

DOUBLE GERANIUM CROWN PRINCE.—Mr. Cannell, of Woolwich, has sent us blooms of his new double Geranium Crown Prince, which was awarded a first-class certificate at the last meeting of the Floral Committee, showing that the colour is much more intense than that of Madame Lemonie, while the plant has the advantage of not being so gross in habit as most of the double varieties.

ABNORMAL CARNATION (*A. B. A.*).—The structure of your Carnation is much the same as that of the Wheat-ear Carnation, wherein all the floral organs assume the form of bracts. The difference between yours and the Wheat-ear is, in the latter the spike is elongated like an ear of Wheat, whereas in yours it is contracted in the form of that of the Canary-grass. You will find all these curious vegetable forms very ably treated on in Dr. Masters's "Vegetable Teratology," a work which every gardener ought to possess, and which we shall take an early opportunity of describing.

GRAPES SHANKING (*G. Musk*).—The Grapes are what are called shanked, a disease generally attributable to bad soil, overcropping, and other conditions, but of which we believe the cause is little understood. We have seen Vines grown in pots and not overcropped, but well treated, produce shanked fruit.

GRASS LAWN (*H. A. E.*).—If you break up your present lawn and sow it down now, it will not be sufficiently solid and thick for you to play croquet on it next summer. The best way will be to take up the whole, select the best turf for relaying, and procure good new turf to make up the quantity required. When your turf is up procure some heavier soil to mix with the staple, and add also a liberal dressing of cow manure, potash salts, and bones. Next season you will have a good turf. This should be done after this dry weather has gone. (*Grass Plot*).—As you object to re turf your lawn, you had better clear out all those patches where the grass has failed, and sow them with a mixture of lawn grasses, which you can procure from any seedman. In autumn top-dress the whole with well-rotted manure, or in February give a dressing of guano and superphosphate in equal proportions.

PEACHES NOT SWELLING (*J. Green*).—It is not from any effect of the sun plus, but from the dry season, that your Peaches have not grown so large. If you had opened a trench round the roots and given them a good watering, in all probability the fruit would have been much larger than they are.

LEAF-SHAPED ROSE PETAL (*H. D. Nash*).—It is simply a proof of the origin of the petal from a leaf. It is a curious freak.

GLASS WALLS (*F. Fane*).—Apply to Mr. Beard, Victoria Works, Dury St. Edmunds—that is, if you mean his glass walls, and not those of "OBSERVER."

NAMES OF PELARGONIUMS (*N.*).—We cannot undertake to name florists' flowers. The French Marigolds are good; we have seen better-marked and larger. The Pelargonium sport is of no value.

CRICKETS ATTACKING NECTARINES (*G. S.*).—The insect gnawing the fruit of Nectarines in your orchard house is the common house cricket, which often in hot summers quits the kitchen hearth and takes up its quarters in congenial situations out of doors.—I. O. W.

PYRETHRUM SEED SOWING (*Subscriber*).—The Golden Pyrethrum seed may now be sown in a sheltered situation in light sandy soil, and the plants may be taken up in October, potted, and wintered in a cold frame or greenhouse. They will be fine for planting out in spring. The Golden Pyrethrum, however, is quite hardy, and the seedlings may be pricked off about 3 inches apart in October, or even as late as November, on a warm border of sandy soil, and they will form good plants for planting in April or May.

FERNS FOR LILY HOUSE (*An Amateur*).—We do not understand what you mean by a Lily house, unless it be a house for aquatic plants, in which case any or all of the exotic Ferns introduced would succeed if it were not that they require shade, which aquatics do not. If you can afford shade to the Ferns without making the house too gloomy, or can do so without shading the aquatics, then you may have stove or greenhouse Ferns, according to the temperature of the structure.

DOUBLE PETUNIAS LOSING COLOUR (*H. E.*).—The double white and purple-blotched Petunias lose colour through decreased vigour in the plants. We advise you to take off cuttings of the young growths now, and strike them in a cold frame or in a hotbed; when well rooted pot them off singly in small pots. To spring shift the plants into larger pots as required, using a compost of two parts turfy loam, one part leaf soil, and one part old cow dung, with a free admixture of sand and charcoal. Keep them in a cool, airy position near the glass, and safe from frost. The flowers will be finer and the foliage larger than on old plants.

POTTING SHOW PELARGONIUMS (*Idem*).—The plants should not be placed in their blooming pots at the first potting after being cut down. Shake them out—that is, remove all the soil from their roots, and place them in pots large enough to hold the roots without cramping. When the plants have made fresh roots and need repotting, as they do when the roots are matting round the sides, they may be put into their blooming pots.

CLEMATIS FOR NORTH WALL (*Idem*).—We have not found the new Clematis Jackmanni, &c., succeeding on a north wall, but C. Vitalba, C. Frankfurtensis, and C. Viticella do tolerably well; the first-named we have seen very fine.

EVERLASTING FLOWERS (*Twelve-years Subscriber*).—We do not think if the words in which the prize is offered are strictly interpreted, that you could exhibit dried Laguruses and other ornamental Grasses in "a collecting of Everlasting Flowers." The heads of such dried Grasses are only a part of the flowers.

Figs (*R. H. W.*).—We propose doing as you suggest, but we must have all that our correspondent has to say on the subject before we decide.

VARIOUS (*Kittie*).—The common wood Hyacinth is the Scilla non-scripta of botanists, the Harebell of common nomenclature. Very little frost and damp destroy the Gaspalum lanatum. Your proposed planting will do very well if you have the crimson or red Tom Thumb Tropaeolum. The latter will want picking off superfluous leaves and seeds as they come. To raise Echeverias for edgings next year, sow at once, merely covering the seeds, prick off the seedlings as soon as sown, and keep airy and rather dry in winter.

SULPHUR ON HOT-WATER PIPES (*A. B. C.*).—If you put the sulphur on the hot-water pipes, either by making a paint with water, or milk, or lime to make it adhere better, the Grapes will not be injured if the heat of the pipes be not above 100°, and a little air be given at the top of the house early in the morning.

CUCUMBERS DAMPING OFF (*Tilney*).—Thrips and neglecting to fertilise the flowers will not cause the fruit to go off at the end. It arises from the growth not being free enough, owing to a deficiency of bottom heat, or a cold and moist atmosphere at top. We think a little more bottom

heat with a brisk top heat would set all right. Vegetable Marrows are indifferent bearers this year, owing to the dry weather.

WOODLICE IN CUCUMBER FRAME. (*M. J. J. J.*)—Place a boiled potato wrapped up in a little hay in a small flower-pot, and lay the pot on its side near the haunts of the woodlice. A number of such baits put down at night, and the contents emptied in the morning into a bucket of boiling water, will considerably thin the woodlice.

PEACHES DISEASED. (*Mrs. W. F. Knutshill.*)—The Peaches are suffering from gum, and probably the trees are also. The cause of this is the roots of the trees having got into an ungenial soil. In autumn let the roots be uncovered and examined, and as some of them will in all probability have thrown down tap roots into the subsoil, let these be cut off, and all the remaining roots encouraged near the surface.

MESSEMBRYANTHEMUM CULTURE. (*H. T.*)—The culture of these plants is not difficult. They require to be grown in a compost of equal parts of light turfy loam, sandy peat, lime rubbish, charcoal or broken pots, and silver sand. If the loam is poor, one part of old cow dung may be advantageously added. Mix the whole well. The pots must be well drained. Small pots only are necessary, or rather they should be small compared with the plants. Put in spring, or when the plants begin to grow. Propagate by cuttings laid on a shelf in the sun a few days to dry at the base, and then insert them in the above compost, with an equal quantity of sand added to it. In summer they succeed out-doors on rockwork in an open, very sunny situation, and are very suitable as window plants for warm south aspects. In winter they need to be kept secure from frost, and ought to have no more water than will prevent the stems and leaves from shrivelling. When growing they require a plentiful supply of water, at other times dryness. Some of the best are *M. densum*, *M. rotundum*, *M. strictum*, *M. conspurcans*, *M. falcatum*, *M. rebratum*, *M. spectabile*, *M. cordifolium*, *M. variegatum*, *M. coccineum*, *M. maculatum*, *M. falcatum*, *M. echinidum*, *M. album*, *M. cylindricum*, *M. bicolorum*, *M. palmatum*, *M. leve*, *M. aurantiacum*, *M. spinosum*, *M. aureum*, *M. barbatum*, *M. polyanthum*, *M. tuberosum*, *M. incurvum*, *M. denticulatum*, *M. blandum*, *M. difforme*, *M. heterophyllum*, *M. cocciniferum*, and *M. inclaudens*. If planted out in summer they will need to be taken up in autumn, potted, and wintered in a house with a temperature not below 35°, nor higher from fire heat than 45°, keeping them near the glass and dry. They are not Everlastings.

PEACHES. (*J. W. Popham.*)—We do not know the Dymond Peach, and never heard of the name. The grower who sold it to you ought to be able to give some account of it. The variety which he supplied you with for Royal George, may probably be Early Victoria, as that is a dark-coloured Peach, and with glandless leaves.

SHOOTS OF VINE DYING. (*B. C. H.*)—This decay and the Grapes shanking, indicate that the roots of the Vine do not supply a sufficiency of sap. They have either descended into a bad subsoil, or they have not a good supply of moisture and nourishment. Give an abundant watering once a week with tepid weak liquid manure, and mulch the surface of the border.

NAMES OF PLANTS. (*Julia.*)—*Achillea Millefolium.* (*D. B.*)—*Cuscuta Trifolia.* (*M. Catterbeck.*)—*Catappa sylvatica.* It does not bloom until of a large size. (*J. S.*)—1, *Asplenium bulbiferum*; 2, *Neprolepis exaltata*; 3, *Urtica erecta* all three for 4, *Platyoma rotundifolia*; 5, *Haltimium elegans*; 6, *Achillea cymosa*; 7, *Achillea*—*Atriplex portulacoides* of Linnaeus, now frequently referred to the genus *Obione*; 8, *portulacoides* of Moquin. (*M. A.*)—Without seeing the flowers of your scented-leaved *Pelargonium* it is impossible to say if it is better than existing named varieties. The leaf you sent will be that of *Achillea Millefolium*. A piece of a Fern frond enclosed with your letter is *Adiantum bipidulum.* (*J. G. S.*)—No. 4 is *Lysimachia Nummularia*, and 5 *Lantana vulgaris* fl. pl.; No. 3, *Gnaphalium marginatum*. The rest in a future issue. (*D. A.*)—1, *Scilla Liliata*, apparently a *Melissa*; specimen in this and the next far too imperfect; 2, a *Habrothamnus* or *Cestrum*; 3, *Cassia levis*. Send better specimens when you make inquiry again. (*E. P.*)—*Palma adiantifolia.* (*S. B.*)—1, *Lactuca dilatata*; 2, *L. tuberosa*; 3, *Lemna spicata*; 4, 8, and 9, all forms of *Athyrium filix-foemina*; 5, *Lactuca Indivisa*; 6, 1, *Polypodium calcareum*; 9, *Polytrichum Lomatites.* (*A. Suber.*)—1, *Bugusia* (or *Complobotrys*) *refugens*; 2, *Eranthium leucocarpum.*

POULTRY, BEE, AND PIGEON CHRONICLE.

A TRIP INTO GLOUCESTERSHIRE AFTER POULTRY.—No. 1.

THERE are many charming bits of scenery in England which are, as yet, to be lying away from railway stations, scarcely known so much as they deserve to be. Or, if they have a railway, it is but an unsatisfactory thing, a single line, which in slowness, perhaps, is meant to be a pleasing reminder of old coaching times; sometimes, too, it comes to an end at apparently nowhere particular, and, perhaps, at a very small station, where two men are yawning, thus making a pretence of doing something, or a lively boy, the only vigorous inhabitant of the district, is whistling a tune which was a popular one ten years ago. But there are often charming bits of scenery close by; one such it was my happy lot to see last week in the district lying near Dursley, in Gloucestershire. Although the Romans left their mark about Dursley, yet something more ubiquitous even than that conquering power gave many of the names to the places around—namely, pasturage and a shepherd's life. Thus in Dursley we have deer-lic; the next parish is Uley—i.e., Ewe-lic; the next Otten, from old-pan; and Lampen Hill from lamp-pan. Doubtless, the shepherds gave the names, and all, save the first, tell of their quiet pasture life.

The valley of Uley is, indeed, a choice piece of scenery—high hills covered with beech trees, there a natural growth; then in contrast to the thick woods, one here long hill, Uleybury, so unlike its well-clothed brothers, and a valley with wood—perhaps too much—and, marvellous this dry season, a glimmer of water and perfectly green grass. Place in this scenery a couple of Gothic churches, a picturesque mansion or two, one smaller, yet its ivy, and its stone tiles, and its air of comfort and refinement, make each traveller instinctively say, "What a nice old place! Who lives there?" I check rein before that house, where lives and has long lived a brother cleric, a brother poultry fancier, and a brother rosarian—a threefold binding-chord. Mine is a second visit, so I know what to expect and whom to look for—the kindly parson himself, his wife, and oh, marvellous! his small family. Then there will be his man Hosea (a parson's man should have an Old Testament name). Then there will be the gardener, apparently given-up entirely to roses, though there is a cabbage here and there; there will be the Dorkings, and the Game Bantams; there will be the selecting and packing-off the poultry for the coming show; there will be the master taking a last loving peep and saying, "I wonder what prizes I shall get—perhaps none at all, for those wretched judges may not see the beauties of my beauties, and yet (here hope sparkles in his eye), I think, that Dorking cockerel will do something." (N.B., He did.) There will be Hosea, gravely and cautiously putting the show roses in their case, dipping the moss in the water, filling the glasses, sorting the roses, and thinking they will get a prize. Hosea was right, they did.

Wednesday morning we start from the valley of Uley for Stroud, driving—that pleasantest way of getting through a short journey in fine and warm weather. Soon we emerge from the lovely valley and begin to climb that long steep hill, Lampen Hill, with a forest of beech trees on our right, and a dip of many hundred feet on our left. Pity we cannot, as far as locomotion is concerned, do away with all hills. Look at the wise Londoners, they only had one hill, Holborn Hill, and they have done away with that. Railways also know no hills; in fact, hills, except to look at, are sad nuisances. The late Mr. Cobden once talked of crumpling-up Russia as he could, suiting the action to the word, crumple up a newspaper, which, perhaps, contained an article against him. I wished he had lived to lower all the hills by filling up the valleys in the roads.

Having at long-last climbed that tedious hill, we come into the stone-wall country, leaving a little on our right Kingscote Park, which has been in the hands of the Kingscotes for nearly a thousand years. A Nigel de Kingscote came over with the Conqueror, and Colonel Nigel Kingscote now represents, as his forefathers did in many generations, a division of Gloucestershire.

Further on, the country improved until we get among decidedly pretty scenery. At Horsley, there stands an empty unused jail, which ugly building though it be, we may look at with pleasure, as it is a happy indication of improved morals. But we get on to Nailsworth, and still the scenery improves, passing Amberley, which gives a title to Earl Russell's eldest son. Reaching soon Woodchester, we are, I suppose, in the golden valley of Stroud, and beautiful it is; not a close-shut-in valley as some of our North Wilts combs are, nor yet a wide valley with hills so far off as scarcely to come into the landscape—wide, and not too wide, with hills well-shaped and well-wooded, indeed the whole of the golden valley has a park-like appearance, so well-grown is the timber. Among the scattered hamlets one caught sight now and then of a fine gable, or ornate house of the Queen Anne date, but factories are also in the valley, which, though indicating wealth and a comfortable livelihood to many, add no beauty to the scene. Art put alongside of Nature must not only, in order to add to the beauty of the landscape, be high art, but must be altered and improved by the hand of Nature, an alteration and improvement stretching over many years before it harmonises with Nature. Thus, how a new monument, or a new church smites the eye; but let the church tower or spire meet the winds of Heaven for years and years and get well weather-stained, how (as witness hundreds of old churches) it adds to the beauty of the view; but new factories can never be improved. This train of thought reminds me of Shakspeare's words in the Winter Tale—

"Yet nature is made better by no mean,
But nature makes that mean: so'er that art
Which, you say, adds to nature, is an art
That nature makes,—the art it elf is nature."

derton & Scholes, Hollinwood. *hc*, T. Walker, jun. *Silver-spangled*.—1 and Cup, H. Beldon. 2, H. Pickles. *Chickens*.—1, H. Pickles. 2, H. Beldon. *hc*, J. H. Howe, Dalton. *Golden-pencilled*.—1 and Cup, H. Beldon. 2, H. Pickles. *hc*, W. Speakman, Nantwich. *Chickens*.—1, T. Wrigley, jun., Middleton. 2, H. Beldon. *hc*, T. Edwards, jun., H. Pickles, jun. *Silver-pencilled*.—1, H. Pickles, jun. 2, H. Beldon. *Chickens*.—1, H. Pickles, jun. 2, H. Beldon. *hc*, H. Pickles, jun. *Black*.—1 and Cup, C. Sedgwick. 2, H. Beldon. **GAME BANTAMS**.—*Any Variety*.—1, J. R. Robinson. 2, J. Frith. *Cock*.—1, J. W. Morris. 2, Harwood & Flockley. *hc*, J. Frith; W. F. Entwisle, Leeds. *Chickens*.—1 and Cup, W. F. Entwisle. 2, J. W. Morris. *hc*, J. Frith; W. F. Entwisle. *Any other Variety*.—1, S. R. Ashton, Holmton. 2, H. Draycott. *hc*, M. Leno; T. C. & E. Newbitt; G. A. Stephens, Walsall. **FRENCH FOWLS**.—1 and Cup, H. Beldon. 2, G. Andrews. *hc*, Rev. N. V. Ridley, Newbury; W. G. Furdon, Driffield; C. Broadbent; G. A. Stephens; J. Drewry, Burton-on-Trent. **C. MORRIS. ANY OTHER VARIETY**.—1, R. Loft, Woodmansey (Sultan). 2, W. Wilky. *hc*, Hon. Mrs. Burrell (Japanese Silkies). **DUCKS**.—*Aylesbury*.—1 and Cup, J. K. Fowler. 2, Mrs. M. Seamons, Aylesbury. *hc*, E. Leech, Kichdale; Mrs. M. Seamons; M. Harrison; Hon. Mrs. Burrell; S. H. Stott, Rochdale; J. Robinson. 2, H. Beldon. 3, H. Pickles, jun. *Teacup*.—2, E. Leech. *hc*, H. B. Smith, Broughton, Preston; T. Wakefield, Gallowance; R. Gladstone, jun. *c*, J. Scotson, Little Byram. *Any other Variety*.—1, C. W. Brierley. 2, H. B. Smith. *hc*, G. Barbour; R. Gladstone, jun. **GEESSE** (Any variety).—1, E. Leech. 2, J. K. Fowler. *hc*, Mrs. M. Seamons; S. H. Stott; E. Leech; D. Bennett, Warrington. **C. R. GLADSTONE, JUN. TURKEYS**.—1, E. Leech. 2, M. Kew, Market Overton. **SELLING CLASS**.—1, T. C. & E. Newbitt. 2, W. A. Taylor. *hc*, H. Beldon; W. A. Taylor; C. W. Brierley. *c*, F. & C. Howard; J. F. Dixon.

JUDGE.—Mr. R. Teebay, Fulwood, Preston.

KEIGHLEY AGRICULTURAL SOCIETY'S POULTRY SHOW.

This was held on the 19th inst. The following are the awards:—

COCHIN-CHINA. *Buff*.—1 and 2, W. A. Taylor, Manchester. 3, T. Stretch, Ormskirk. *Chickens*.—1 and 2, W. A. Taylor. 3, C. Sidgwick, Keighley. *hc*, C. Sidgwick; T. Stretch. *Any Colour*.—1 and 3, W. A. Taylor. 2, H. Beldon, Gostock. *hc*, T. Stretch. *Chickens*.—1, W. A. Taylor. 2 and 3, C. Sidgwick. *c*, J. H. Dawes, Birmingham. **SPANISH** (Black).—1, C. W. Brierley, Middleton. 2, H. Wilkinson, Farby. 3, H. Beldon. *Chickens*.—1, C. W. Brierley. 2, H. Beldon. 3, J. W. Cannon. *hc*, J. J. Booth. **HAMBURGERS**.—*Silver-pencilled*.—1, H. Beldon. 2 and 3, H. Pickles, jun., Earby. *Chickens*.—1 and 2, H. Beldon. 3, H. Pickles, jun. *Silver-spangled*.—1 and Cup, H. Beldon. 2, H. Pickles, jun. *Chickens*.—1, H. Beldon. 2, H. Pickles, jun. 3, T. Fawcett, sen., Baildon. *Golden-spangled*.—1, J. Newton. 2, H. Pickles, jun. 3, H. Beldon. *hc*, W. Driver, Keighley. *Chickens*.—1, W. Driver. 2, T. & W. Walker, Denton. 3, C. E. Palmer, Highthorn, Warwick. *hc*, H. Pickles, jun. *Golden-pencilled*.—1, H. Beldon. 2, H. Pickles, jun. 3, S. Smith, Northwarren. *Chickens*.—1, H. Pickles, jun. 2, H. Beldon. 3, T. Kinder, Middlethwait. *Black*.—1, H. Beldon. 2, T. & W. Walker. 3, H. W. Bingsworth, Ilke. *Chickens*.—Cup and 3, C. Sidgwick. 2, S. Haldiffe. *hc*, J. Cockeroff, Hawkecliffe, Keighley. **PORTRAI**.—1, 2, and 3, H. Beldon. *Chickens*.—1 and *hc*, H. Pickles, jun. 2, H. Beldon. 3, J. Bowker, Keighley. **DORINGS**.—1 and 3, T. Briden, Earby. 2, W. A. Taylor. *Chickens*.—1, T. E. Kell, Wetherby. 2, T. Briden. 3, J. J. Waller, Kendall. *Game*.—*Red*.—Cup, C. W. Brierley. 2, T. & J. Robson, Bishop Auckland. 3, W. Spencer, Tharworth. *Chickens*.—1 and 2, J. Carlisle. 3, H. Jennings, Alton. *Any other Variety*.—1, C. E. Farley. 2, H. M. Jubb, Hull. 3, T. & J. Robson. **T. SURFLEIGH, HALL**.—1, H. Beldon. 2, H. Pickles, jun. and Co., Keighley. 2, M. Jowett, Clayton. 3, Green & Sutcliffe, Queensbury. **ANY OTHER DISTINCT BREED**.—1, J. H. Pickles, Birdale, Southport. 2, H. Beldon. 3, E. Leech, Rochdale. *hc*, W. Wildy, Cosham. *Chickens*.—1, E. Leech. 2, W. O. Quibell, Newark. 3, W. A. Taylor. **BANTAM**.—*Game*.—1, G. Anderton, Accrington. 2, W. F. Entwisle, Cleckheaton. 3, T. Dyson. *hc*, F. Steel, Halifax. *Chickens*.—1, G. Noble. 2, W. F. Entwisle. 3, H. Greenwood and Buckley, Accrington. *hc*, F. Steel; W. F. Entwisle. *Any other Distinct Breed*.—1, J. W. Cannon. 2, S. & R. Ashton, H. Beldon. *Chickens*.—1, H. Beldon. 2, T. C. Harrison, Hull. 3, W. H. Robinson, 1 oncle. **DUCKS**.—1, E. Leech. 2, J. Clayton. *Aylesbury*.—1 and 2, H. D. Leech. 3, T. Wilson, Farnhill. *Any other Variety*.—1, J. Dixon, Bradford. 2, C. W. Brierley. 3, T. C. Harrison. *hc*, S. & R. Ashton; J. Dixon. **GEESSE**.—1 and 2, E. Leech. 3, Rev. G. Huxley, Stillingfleet. **SELLING CLASS**.—*Cock*.—1, H. Pickles, jun. 2, J. Berry, Silsden. 3, H. Beldon. *hen*.—1, J. L. Booth. 2, H. Wilkinson. 3, J. Berry. *hc*, H. Pickles, jun.

PIGEONS.

Cup for best pen, E. Horner, Harwood. **PORTER OR CROPPER**.—*Cock*.—1 and 2, E. Horner. 3, J. Hawley, Bingley. *hen*.—1, W. Harvey, Sheffield. 2 and 3, J. Hawley. 3, E. Horner. **CARRIER**.—*Cock*.—1, 2, and 3, F. Horner. *hen*.—1, 2, and 3, E. Horner. **TUMBLERS**.—*Almond*.—1, E. Horner. 2, J. Fielding, jun., Rochdale. 3, W. Harvey, Sheffield. *Mottled*.—1, J. Hawley. 2, J. Fielding, jun. 3, H. Yardley. **FAVDS OR BARNS**.—1, 2, and 3, J. Fielding, jun. **OWLS**.—1, W. Harvey. 2, J. Fielding, jun. **TURKEYS**.—2, B. D. Banne, Boston. Extra 2, E. Horner. 3, H. Yardley. **JACOBINS**.—1 and 2, J. Thompson. 3, E. Horner. **FANTAILS**.—1, H. Yardley. 2, J. Thompson. 3, F. Horner. **BURNS**.—1 and 3, E. Horner. 2, J. Fielding, jun. *c*, H. Yardley. J. W. Cannon. **DRAGONS**.—1, H. Yardley. 2, J. Mitchell, Mosley. 3, F. Graham. *c*, J. Jowett, Ilke. W. Lund, Shipley. **TRUMPETERS**.—1, J. Hawley. 2, W. Harvey. 3, F. Horner. **MAGPIES**.—1, 2, and 3, E. Horner. **ARCHANGELS**.—1, E. Horner. 2, J. Thompson. 3, H. Yardley. **ANY OTHER BREED**.—W. Lund, Shipley. 2, E. Horner. 3, J. Fielding, jun. *c*, H. Yardley. W. Harvey. **SELLING CLASS**.—1, W. Lund. 2, A. H. Easton, Hull. 3, J. Thompson.

RABBITS.—*Long-eared*.—*Black*.—1, A. H. Easton. 2, G. Johnson, Kethring. *hc*, C. Gravid, jun., Thorne. *Doc*.—1, G. Johnson. 2, A. H. Easton. *hc*, C. Gravid, jun. *Any other Description*.—*Black*.—1, A. H. Easton. 2, P. Moulson, Little Horton. *Doc*.—1, A. H. Easton. 2, P. Moulson, *hc*, Wood & Poole, Bradford.

JUDGES.—*Poultry*: Mr. E. Hewitt, Eden Cottage, Sparkbrook, Birmingham; Mr. R. Teebay, Fulwood, Preston. *Pigeons*: Mr. W. Smith, Halifax.

WHITBY POULTRY SHOW.

We published last week the awards made to the poultry and Pigeons at the Whitby Agricultural Society's thirty-sixth annual Show. The weather being extremely fine and the visitors very numerous, the receipts at the gates were much greater than at any former Show. The arrangements were everything that could be desired. The *Dorkings* did not form a large class; the prize chickens were very good. Many of the *Spanish* were in deep moult; the first-prize chickens, however, were good. In the class for Red *Game*, Mr. Julian was first with a very good pen of Black Reds; and Mr. Robson, of Bishop Auckland, second with an excellent pair of Brown Reds. The two pens of *Duckwings* belonging to the same gentleman were also first-rate. Of

Brahmas there was a large entry, but many of them were much out of condition. Some of the chickens were of great merit. The *French fowls* were tolerably numerous, and the two prize pens of great merit. Most of the *Hamburgh* classes contained some good birds, but the entries were not so numerous as we should have wished. The *Ducks* and *Geese* were well represented; and all the classes of *Pigeons* contained many first-class specimens.

The local cups for the best pen of chickens, of the large breeds, was awarded to Mr. Readman, for *Cochins*; that for *Game* or *Hamburghs*, to Mr. Webster; and for *Ducks*, to Mr. Barn, for a good pen of *Black East Indian*.

PENISTONE POULTRY SHOW.

The seventeenth annual Show of poultry took place at Penistone on Thursday last, upon the admirably adapted grounds belonging to Mr. Unwin. There may have been years when the number of entries have been larger, but the different classes have never been better represented. The poultry included some of the finest birds in the kingdom. The prize for *Dorkings* was carried off by a very fine pen. *Spanish* were well represented. The *Polands* shown were remarkable for their excellent quality. Of *Hamburghs* there was a large display, and finer birds could not be found. The *Game* classes caused some excitement, the several kinds shown being admirable. The competition between Mr. C. Chalouner and Mr. F. Sales was exceedingly keen. The *Cochin-Chinas* were poorly represented, owing to most of this class of birds being out of feather. However, Mr. Harvey showed one excellent pen.

DORINGS.—1, Hon. H. W. Fitzwilliam, Wentworth Woodhouse. 2, W. Harvey, Sheffield. *Chickens*.—1, W. Parkin. **SPANISH** (Black).—1 and 2, Burch & Boulter, Sheffield. *Chickens*.—1, E. Brown. 2, Burch & Boulter. **COCHIN-CHINAS**.—1, W. Harvey. 2, W. Tomlin, Sheffield. *Chickens*.—1, Burch & Boulter. 2, W. Whiteley, Sheffield. **POLANDS**.—1, W. Harvey. 2, J. Batty. **HAMBURGERS**.—*Silver-spangled*.—1, W. Harvey, Sheffield. *Chickens*.—1, W. McMillon, Glossop. *Golden-pencilled*.—1, W. Harvey. 2, Burch & Boulter. *Chickens*.—1, Burch & Boulter. *Silver-pencilled*.—1, W. Harvey. **GAME**.—*Black-breasted and other Reds*.—1, C. Chalouner, Whitwell. 2, F. Sales, Crowle. *hc*, W. J. Cope, Barnsley. *Cockerel and one Hen*.—1, B. Burton, Thurgoland. 2, C. Chalouner. *hc*, F. Sales. *Duckwings and other Greys and Blues*.—1, C. Chalouner. 2, F. Sales (Duckwings). *hc*, W. J. Cope, Barnsley. *Chickens*.—1, J. B. Epworth. 2, C. Chalouner. *hc*, F. Sales (Duckwings). *Whites and Pales*.—1, F. Sales. 2, C. Chalouner. *Chickens*.—1, F. Sales. 2, C. Chalouner. **ANY BIRD**.—1, Hon. H. W. Fitzwilliam (Cree-Cree). 2, W. Whiteley (Brahmas). *Chickens*.—1, W. Harvey. 2, W. Whiteley. **BANTAMS**.—1, C. Chalouner. 2, J. North, New Mill. **TRAFKYS**.—1, J. Tickett, Penistone. 2, E. Booth, Wharfedale Side. **GEESSE**.—1, C. Chalouner. **DUCKS**.—*White Aylesbury*.—1 and 2, Shillito, Pittsboro. *Other Colour*.—1, J. Flood, Penistone. 2, C. Chalouner.

JUDGES.—Mr. William Wood, Sheffield, and Mr. Thomas Wilkinson, Holmfirth.

DEANE AND BOLTON POULTRY SHOW.

This was held on the 18th inst., at Deane, near Bolton, in connection with the Agricultural and Horticultural Show, and the day being fine there was a large attendance of visitors. The following are the awards:—

SPANISH.—1, F. & C. Howarth, Newfield, Haslingden. 2, C. W. Brierley, Middleton. **DORINGS**.—1, C. W. Leaverley. 2, J. Watts, King's Heath, Birmingham. *hc*, J. Stott. **GAME**.—1 and 2, C. W. Brierley. *c*, J. Wallas. *Cock*.—1 and 2, C. W. Brierley. *hc*, J. Wallas, Deaton. **COCHIN-CHINA**.—1, J. Stuch, Tamworth. 2, C. W. Brierley. *c*, G. Anderton, Accrington. **BRAMS**.—1 and 2, J. H. Pickles, Birby, Southport. **HAMBURGERS**.—*Golden-pencilled*.—1, T. Wrigley, jun., Tonge Hall, Middleton. *Silver-pencilled*.—1 and 2, J. Platt, Deane. *Golden-spangled*.—1, T. Bolton, Handforth. *Silver-spangled*.—1 and 2, J. Fielding, Newchurch. **POLANDS**.—1 and 2, P. Unsworth, Lawton, Newton-le-Willows. **ANY OTHER VARIETY**.—1, C. W. Brierley. 2, S. H. Stott. **BANTAMS**.—*Game*.—1, T. Sharples, Forest Bank, Rawtenstall. 2, G. Anderton, *hc*, T. Sharples; J. Wallas. *c*, N. Cook, Choultun; J. Howarth, Holcombe Harriers, Colburnton. *Any other Variety*.—1, N. Cook. 2, S. & R. Ashton, Rochdale. *hc*, N. Platt, Deane. **BURNS**.—*Aylesbury*.—1, E. Leech, Rochdale. 2, S. H. Stott. *hen*.—1, T. Bolton. *Silver-spangled*.—2, S. H. Stott. *hc*, J. Scotson, Little Byram (2). *Any other Variety*.—1, C. W. Brierley. 2, S. & R. Ashton, Mottram. **GEESSE**.—1, E. Leech. 2, S. H. Stott. *hc*, W. Raby, Bolton. **TURKEYS**.—1, E. Leech.

PIGEONS.

CARRIER.—1, D. Bromley, Over Hillton, 2, W. Markland, Deane. **TUMBLERS**.—1, F. Moore, Barnley. 2, H. Yardley, Birmingham. **ENGLISH OWLS**.—1, A. Jackson, The Whites, Heaton. 2, D. Bromley. *hc*, J. Watts, Birmingham. **CHOPPERS**.—1, H. Yardley. **FANTAILS**.—1, J. F. Lovelock, Newark-on-Trent. 2, J. Kemp, Haslingden. **DRAGONS**.—1, J. P. Unsworth. 2, J. Watts. *hc*, D. Bromley. **ANTWERPS**.—1, H. Yardley. 2, W. Markland. **BURNS**.—1, H. Yardley. 2 and D. Bromley. **ANY OTHER VARIETY**.—1, D. Bromley. 2, P. Unsworth. *hc*, F. Moore. **EXTRA CLASS**.—1, Withheld. 2, D. Bromley (Blue Carriers).

JUDGES.—Mr. S. Fielding, Thretham, and Mr. T. S. Ridpath, Outwood Hall, Hanforth.

WOODSOME POULTRY SHOW.

The Woodsome Society's fifteenth Show was held on the 17th inst. The arrangements were good, the birds well attended to, and the exhibitors treated with the utmost courtesy.

Dorkings are neglected in this part, and there were no entries, and of *Spanish* and *Cochins* there were very few specimens. *Game* were adult birds, and not in the finest bloom, though good in hand. Of *Brahmas* there were some good specimens, the first-prize pen being in excellent order. The second-prize birds were better in marking, but out of feather. The *Hamburghs* were all good. In the *Game Bantam* class the competition was very close; the awards were made to *Black Reds*. In the class for any other variety of *Bantams*, *Blacks* were first, and *Japanese* second. The *Roman Ducks* were large, and the winners correct in points, though some of the rest were bad in head.

Of *Pigeons*, the best Carriers were a good pair of Duns, and two winning Pouters were good in limb and feather. Fantails were of but moderate quality, as also the Barbs, but the Trumpeters were good.

The *Rabbit* classes contained some good specimens, notably the Lop-ears, and a handsome Silver-Grey Buck.

SPANISH.—1, H. Beldon, Goltstock. 2, H. Staden, Woodsome Lees. COCHIN.—CHINA.—*Cinnamon or Buff*.—1, H. Beldon. *Any other Variety*.—1, J. White, Whitley Neighbour. 2, H. Beldon. GAME.—Black-breasted or Brown Bell.—1, E. Aikroyd, Evesham. 2, W. J. Cope, Barnley. *he*, J. Smith, Kirkburton. POLAND.—1, H. Beldon. BRAHMS.—1, E. Leech, Roshdale. 2, H. Beldon. H. Lacy, Hebdon Bridge. *c*, J. Brooke, Huddersfield. HAMPSHIRE.—*Gold-pencilled*.—1, H. Beldon. *Gilt-spangled*.—1, H. Beldon. 2, J. White. *Silver-pencilled*.—1, H. Beldon. *Silver-spangled*.—1, H. Beldon. BANTAMS.—*Game*.—1 and *he*, G. Noble, Stancliff. 2, F. Steel, Halifax (2). *Any other Variety*.—1, T. Dyson, Halifax. 2, H. Beldon. DUCKS.—*Hy-bury*.—1, E. Leech. 2, H. Staden. *Bant*.—1, E. Leech. 2, J. White. J. Crossland, Huddersfield. *he*, F. Brooke; J. Crossland. TURKEYS.—1, E. Leech. ANY BREED.—*Chickens*.—1, F. Steel. 2, J. Bradbury, Bradshaw, Anstonley. *c*, J. Clegg, Dalton.

PIGEONS.

CARRIERS.—1, H. Yardley, Birmingham. PORTERS.—1 and 2, J. Hawley, Bingley. TOWNERS.—1, J. Hawley. 2, H. Yardley. *c*, J. Hawley; J. H. Sykes, Huddersfield. FANTAILS.—1, J. Hawley. 2, H. Yardley. Jacobins.—1 and 2, J. Hawley. *he*, H. Yardley. *c*, C. Gravel, jun. TRUMPETERS.—1 and 2, J. Hawley. Extra 2 and *he*, T. Kaye, Honley. *c*, J. H. Sykes (2). BARNS.—1, H. Yardley. 2, J. Hawley. *c*, T. Kaye; J. H. Sykes. DOVECOATS (Common).—1, A. Roberts. 2, J. Hawley. *he*, J. Hawley; J. Sykes, Almondbury; H. Staden. EXTRA STOCK. 1 and 2, T. Kaye (Blue Dragons and Turbots).

RABBITS.—*Buck*.—1, C. Gravit, Thorne. 2, Robinson & Glew, Wakefield. *he*, J. Armistage, Almondbury Bank. *c*, E. Butterworth, Roshdale. *Do*.—1, C. Gravit. 2, A. Doughton, Dalton. *he*, J. Armistage; J. Oldfield; E. Butterworth.

JUDGE.—Mr. E. Hutton, Pindsey, Leeds.

WHITBY CANARY SHOW.—Was it not Dickens who, at the close of a preface, said with reference to the familiar cover in which the monthly parts of *Lis* works appeared, that he would some day put forth his "two green leaves" again? Whitby, the first Show of the season, has put forth its two green leaves, and I hope it is in the hands of all fanciers. It is an excellent schedule containing nineteen classes of Canaries, three of Mules, and two of foreign birds, for open competition, exclusive of district prizes. The Show is advertised for September 13th—rather early it is true, but it is held in connection with the flower show; and I can assure exhibitors that, apart from the great care and attention bestowed on the birds (which of itself is one distinctive feature of the Whitby executive), they will be seen by a concourse of visitors such as they will not, probably, greet again on this side of the Palace Show. Now, sire, what kind of a season have you had? Who is to the front this year? Let us see what you have moulted through for Whitby, and may the best man win.—W. A. B.

A HUNGARIAN METHOD OF CONTROLLING THE FERTILISATION OF THE QUEEN BEE.

The following article from the pen of Mr. A. Sémlietz is translated from a recent number of the German "Bee Journal":—

"Some time ago I was informed by the Chevalier de Azula that Mr. Johann Dax, of Güns, Hungary, had a method of insuring the fertilisation of a queen bee by any drone which he chose to select, and under his own immediate supervision. He stated that Mr. Dax excised a royal cell the day before its occupant would hatch out, and placing it in a cage permitted the young queen to emerge therein. She was afterwards transferred with a few workers to a suitable receptacle, and a selected drone being introduced, fertilisation was speedily accomplished.

"Following these instructions I performed several experiments last spring, but was in every case unsuccessful. Having occasion early in the autumn to proceed to Penkafeld, in Hungary, I resolved to extend my journey to Güns. Here I found Mr. Dax, who received me cordially and imparted much interesting information collected by him in the course of forty years' practical experience in bee-culture, besides allowing me to peruse a manuscript treatise embracing his observations and opinions, under the head of 136 questions and answers, forming literally a bee-keeper's catechism.

"It follows that the pure fertilisation of queen bees, and the best means of securing it, soon became the subject of conversation, and he unreservedly described his mode of accomplishing that object. As he generously allows me to make this information public, I now do so for the benefit of bee-keepers generally. The importance of the discovery, if it should prove reliable, induces me to publish it at once, although I should have preferred testing it first more thoroughly myself. The few experiments which I have been able to make failed, as it seems to me, only because the weather was so cold that I could

not prevent the embryo queens from becoming chilled in their cells; but that it is possible, by using the requisite precautions to procure the fertilisation of queens in the manner described by Mr. Dax, I consider unquestionably true. I now proceed to details.

"We require for our purpose in the first place, an ordinary pipe cover made of very fine wire. This is fastened to a small piece of wood less than a quarter of an inch thick, and thus becomes a regular queen-cage. The wood must, however, be sufficiently large to entirely cover the feeding-hole at the top of the hive, and must also have a circular aperture which will permit a queen cell to pass easily. Another thin bit of wood is also required, to which a royal cell is fastened by means of melted wax, and this, being laid on the queen cage with the royal cell passing through its central aperture, closes it entirely. We next require a piece of perforated zinc 6 or 7 inches square, and lastly a glass box 6 inches square by 7 inches high. This is entirely open at the bottom, and has small openings at the top for ventilation, as in a lantern. Through one side of the frame of this glass case is passed a pointed wooden skewer, on which we can easily hang a bit of honeycomb. These are all the materials required.

"If a hive contain many royal cells we must note the date on which each becomes sealed over, and on the seventh day a queen cell must be cut out and fastened with a little wax to the covering board, which must be put over the opening of the queen-cage with the cell projecting inside, taking care that sufficient space is left to permit the queen to crawl out. We then open the feeding-hole at the top of the hive from which the cell has been taken, and put the queen-cage over it, allowing it to project into the hive as far as the wood to which it is fastened will permit. A piece of paper should then be pasted over all, so that no heat may escape, and a blanket may be laid upon this. By raising this blanket and the bit of wood to which the cell is attached we can readily ascertain whether the queen has emerged from it or not. We then wait until the fourth or fifth day, or, in short, the first fine day after the third, which is the day on which queens usually take their wedding-flight. The little cage is now raised with all the bees which adhere to it, the feeding-hole covered with the perforated zinc, and the glazed box, which must be furnished with a bit of honeycomb, placed on the top. The bees and queen are then introduced through the ventilator at the top into the box to the number of at least one hundred, and if those adhering to the cage are not sufficient the perforated zinc must be slightly drawn back until enough have ascended. The glazed box is then darkened, and between the hours of eleven and three a drone is added, when you may watch their intercourse. If this does not occur on the first day, which, however, is generally the case, before three o'clock, it will take place the next day about the same time.

"Mr. Dax assures me that having tried this process many times, he has almost always succeeded with the first drone, but that the second never failed.

"In addition to the undoubted veracity of Mr. Dax himself there are other good reasons for presuming that a properly conducted experiment would ensure a successful result. Why should not fertilisation occur within the hive itself? Because in the crowded condition of the colony it evidently could not be effected without a disturbance and commotion endangering the life of the queen, and under these circumstances it has been provided that natural instinct should compel the queen to leave her hive for this purpose. Even if the bee-keeper should interfere by catching, confining, and removing the queen, she would still be in a state of alarm and endeavour to effect her escape and return to the hive—excitement and distress subduing every other passion or natural impulse. Whether a queen thus removed be liberated in a roomy chamber and permitted to fly amidst workers and selected drones, or allowed to take wing in the open air, restrained only by a silken filament, the desired result will rarely be attained; but under the treatment prescribed by Mr. Dax she becomes neither alarmed nor excited, being born in a state of confinement, and when permitted to mingle with a few workers she feels free and at her ease, and readily yields to her natural impulse to provide for the increase of the little colony. If then a mature drone be introduced, fertilisation is almost certain to follow, because from the small number of workers present (clustered also for the most part on the inserted honeycomb), no interference or commotion need be apprehended. These are the reasons which induce me to look with confidence for a successful result."

The above process certainly appears by far the most likely of any that have yet been devised to secure the desired end, and I

much regret that it is now too late in the season for me to submit it immediately to the test of experiment.—A DEVONSHIRE BEE-KEEPER.

THE BIGGEST PIE ON RECORD was made at Lowther Castle, in Westmoreland, in the year 1762, and was sent up as a present to the King. It contained 2 geese, 4 ducks, 2 turkeys, 4 wild-fowls, 1 wild goose, 6 wild ducks, 3 teal, 2 starlings, 12 partridges, 15 woodcocks, 2 guinea-fowls, 3 snipes, 6 plovers, 3 water-hens, 6 widgeons, 1 curlew, 46 yellow-hammers, 15 sparrows, 2 chaffinches, 2 larks, 3 thrushes, 1 field-fare, 6 pigeons, 4 blackbirds, 20 rabbits, 1 leg of veal, half a ham, 3 bushels of flour, 2 stoues of butter. The whole pie weighed 22 stone. This must have been the original pie commemorated in the nursery rhyme—

"When the pie was opened
The guests began to sing
'Is not this a dainty dish
To set before the king?'"

—(Food Journal)

OUR LETTER BOX.

BREEDING TURKEYS AND GESE (*A Constant Subscriber*).—Most breeders prefer early-hatched young hen Turkeys, and seldom keep them after the second or third year. Young cock Turkeys are preferred, especially if the hens are old ones, but there is little objection to using a three-year-old bird; we do not advise an older. You may use very old Geese, but you want fresh and young ganders. We have known a Goose doing good duty at eight years old, and we have been told of some that were positively patriarchal. We do not advise you to keep Aylesbury Ducks after the second year—that is, after breeding from them two seasons. None of the non-sitters will last so long as those that become broody. We advise the Toulouse as the best breeding Geese; but as they do not sit we say of them, and of Aylesbury Ducks, Renew your stock frequently.

LEGS OF PILE GAME FOWLS (*H. L. C.*).—There is no fixed colour for the legs of Game fowls, but in almost every instance willow are preferred. Some, however, like yellow for Piles, especially in the Worcestershire district. Of late years willow and lead-coloured seem almost to have monopolised the strains. White, yellow, and carpare seldom seen. There was a time when yellow were thought almost indispensable to Duckwings, but now they have nearly disappeared. Of course every bird in the pen must have the same shade, but if that were accomplished we should look only to the more important points of the birds.

BREEDING PHEASANTS (*Pheasant*).—We know no other. Lengthy treatises on these subjects are made up of non-essentials. Young hen Pheasants lay the earliest eggs. Two-year-old birds lay the largest number. The old hens require to be put to young cocks, and they will then go on well for years. It is well, however, and nothing is easier in a well-managed preserve, to turn out the hens after they have bred the second time, and put others in their places. The number of pens you have for adult birds must depend on the number of birds you wish to keep up. Your old birds are now, of course, out of the laying pen, and in the winter pen. Let those that have already bred two seasons grow their wings and fly away. Replace them with young birds from which you have bred this year for the first time, and in the pen they vacate put this year's points. By doing this you will always have a succession of two-year birds, and at no extra expense. These young hens that are to lay next season, and afterwards be your two-year-olds, should have their wings cut now, and be penned. A Pheasant that has had its liberty, although tame-bred, never, if caught again, becomes a tame bird to be depended upon for breeding in pens.

GAME CHICKENS—DUBBING (*Pile*).—It is very rare to find chickens that are deserted by the hen at a mouth do any good; but they should never be allowed to perch, as the breast bone must thereby become crooked. There is no cure for it, and it is a disqualification everywhere. Chickens that are deserted by their mother, should for some weeks be allowed to roost in their rip. They huddle together, and keep themselves warm, and it is better for them, while their bones are forming; whereas if they perch while they have cartilage instead of bone, their legs cannot support them, and their breasts rest on the perch. The bone is soft, and takes the impress of it. They may be dubbed at six or seven months old, but care must be taken not to perform the operation while feathers are forming. They are then in cockers' parlance in "bloody stub," and cannot bear the operation. Scissors used by grooms in clipping horses are good for dubbing. They are curved. The gills are taken off close, and the deaf-ears. The cuts are black the next day, and they soon clearise. The birds suffer so little, that if all that is removed be chopped up, they will eat it directly. It takes two persons to perform the operation properly.

FATTENING DUCES (*J. H.*).—With Ducks as with human beings, exercise is not favourable to fattening. Shut them in a small pigstye if you have one; if not, in some place of the same character. Feed them on oats, bran, and oatmeal, put in a shallow vessel—say from 1½ to 2 inches deep, add a little gravel, and cover the whole with water.

COLOUR OF THE EYES OF ARCHANGEL PIGEONS (*S. Smith*).—We never impugn the judgment of judges, for their decision is, as to any certain show, a final decision. However, we think that orange eyes suit best with the plumage of the Archangel, and prefer them decidedly to pearl colour.

RABBITS—LOP-EARED, SPANISH, ANDALUSIAN, AND PATAGONIAN (*Inquirer*).—The Lop-eared Rabbit is the variety, the point of which is length of ears, and the longer the better. A specimen with ears 23 inches long is good. The colour is of no importance if rightly distributed over the body. The Andalusian is a native of Spain, of large size, weighing from 12 to 18 lbs., colour grey, hair glossy and smooth. The ears are generally long and dangling, as if inclined to be half lop, at least, longer than in all the other varieties, Lop-ears excepted. This is at times also designated the Ram Rabbit. The Patagonian is another large variety more frequently found in France, and the sort seeming to be the

greatest favourite here is of a light yellow, or almost cream shade, so called; weight about from 12 to 15 lbs. Ears shorter and more erect than those of the Andalusian. The last two varieties are scarce, but they are valuable for the table.

CANARY (*Bird Fancier*).—Write to W. A. Blakston, Esq., 22, Norfolk Street, Sunderland.

GOLDFISH (*H. L.*).—Mr. G. H. King, 190, Great Portland Street, London.

OATS GROUND, &c. (*Inquirer*).—Crushed oats are oats crushed between two fluted rollers. Ground oats are the whole grain, including the husk, ground to a coarse flour, and oatmeal is the kernel of the grain only, ground to a coarse or a finer meal.

CANVAS HIVE COVER (*M. J. P.*).—We are unable to say where this can be obtained.

MOUSE AND BEETLE TRAPS (*Perplexed*).—For information respecting the prices of the inventions to which you refer apply at 10, Essex Street, Strand, London.

METEOROLOGICAL OBSERVATIONS

In the Suburbs of London for the week ending August 23rd.

DATE.	BAROMETER.		THERMOMETER.				Wind.	Rain.
	Max.	Min.	Air.		Earth.			
			Max.	Min.	1 ft.	2 ft.		
Wed... 17	29.977	29.971	74	40	64	61	N.	.00
Thurs... 18	29.886	29.708	83	49	64	61	W.	.00
Fri... 19	29.910	29.756	69	33	66	61	N.	.00
Sat... 20	30.041	29.968	74	32	63	61	W.	.00
Sun... 21	30.103	30.076	71	33	60	60	N.	.00
Mon... 22	30.021	29.685	69	46	61	59	S.W.	.78
Tues... 23	29.805	29.735	70	42	59	58	N.W.	.00
Mean...	29.963	29.843	72.86	39.18	62.43	60.14	..	0.78

- 17.—Overcast, fine; densely overcast; clear and fine.
- 18.—Very fine; exceedingly fine; clear and fine.
- 19.—Very fine; cloudy, but fine; clear and fine.
- 20.—Exceedingly fine; very fine; cloudy, but fine.
- 21.—Very fine; cloudy but fine; overcast, heavy clouds.
- 22.—Very fine; overcast, fine; heavy rain.
- 23.—Overcast, damp; cloudy, but fine; clear and fine.

COVENT GARDEN MARKET.—AUGUST 24.

Our chief demand is now among the rougher descriptions of goods which are supplied in very large quantities, and, consequently, the sale must be forced at a low price to dispose of it. Continental supplies are also heavy, notwithstanding the interruption caused by the war. Potatoes are good and a fair steady trade is doing.

FRUIT.

	s.	d.	s.	d.		s.	d.	s.	d.			
Apples.....	4	sieve	1	0	2	0	Mulberries.....	lb.	0	9	0	0
Apricots.....	doz.	1	0	3	0	Nectarines.....	doz.	3	0	6	0	
Cherries.....	lb.	0	5	1	0	Oranges.....	£	100	0	14	0	
Chestnuts.....	bushel	0	0	0	0	Peaches.....	doz.	5	0	10	0	
Currants.....	doz.	0	4	0	0	Pears, kitchen.....	doz.	0	0	0	0	
Black.....	doz.	0	4	0	0	Gessert.....	doz.	1	0	3	0	
Figs.....	doz.	1	0	4	0	Pine Apples.....	lb.	2	6	5	0	
Filberts.....	lb.	0	9	1	0	Plums.....	doz.	0	4	3	0	
Cobs.....	lb.	0	9	1	0	Quinces.....	doz.	0	0	0	0	
Gooseberries.....	quart	0	0	0	0	Raspberries.....	lb.	0	6	1	0	
Grapes, Hothouse.....	lb.	2	0	6	0	Strawberries.....	lb.	0	0	0	0	
Lemons.....	£	100	10	16	0	Walnuts.....	bushel	10	0	16	0	
Melons.....	each	1	0	4	0	do.....	£	100	10	0	2	

VEGETABLES.

	s.	d.	s.	d.		s.	d.	s.	d.		
Artichokes.....	doz.	0	0	0	0	Leeks.....	bunch	0	4	0	0
Asparagus.....	doz.	1	0	0	0	Lettuce.....	doz.	1	6	3	0
Beans, Kidney.....	doz.	4	0	0	0	Mushrooms.....	pottle	3	0	4	0
Broad.....	bushel	0	0	0	0	Mustard & Cress.....	punnet	0	2	0	0
Beet, Red.....	doz.	2	0	3	0	Onions.....	bushel	4	0	6	0
Broccoli.....	bunch	0	0	0	0	Pickling.....	doz.	0	4	0	0
Brussels Sprouts.....	doz.	0	0	0	0	Parsley.....	sieve	8	0	0	0
Cabbage.....	doz.	1	0	2	0	Parsnips.....	doz.	0	9	1	0
Capsicums.....	doz.	1	0	0	0	Peas.....	quart	0	0	0	0
Carrots.....	bunch	0	4	0	8	Potatoes.....	bushel	3	0	5	0
Calliflower.....	doz.	2	0	6	0	Kidney.....	do.	4	0	6	0
Celery.....	bundle	1	0	2	0	Radishes.....	doz. bunches	0	0	0	0
Colewort.....	doz.	3	0	6	0	Rhubarb.....	bunch	0	0	0	0
Cucumbers.....	each	0	6	1	0	Savoy.....	doz.	0	0	0	0
pickling.....	doz.	2	0	4	0	Sea-kale.....	basket	0	0	0	0
Endive.....	doz.	2	0	0	0	Shallots.....	lb.	0	6	0	0
Fennel.....	bunch	0	3	0	0	Spinach.....	bushel	3	0	0	0
Garlic.....	lb.	0	8	0	0	Tomatoes.....	doz.	1	0	1	0
Herbs.....	bunch	0	3	0	0	Turnips.....	bunch	0	6	0	0
Horseradish.....	doz.	8	0	5	0	Vegetable Marrows.....	doz.	2	0	3	0

POULTRY MARKET.—AUGUST 24.

There is a good supply of poultry and an average trade. Grouse are unusually plentiful.

	s.	d.	s.	d.		s.	d.	s.	d.		
Large Fowls.....	3	0	to	3	6	Grouse (young).....	1	9	to	2	0
Smaller ditto.....	2	6	3	0	0	Pigeons.....	0	8	0	9	
Chickens.....	1	9	2	0	0	Rabbits.....	1	4	1	5	
Ducks.....	2	0	2	6	0	Wild ditto.....	0	8	0	9	
Geese.....	5	6	6	0	0	Hares.....	0	0	0	0	
Turkeys.....	0	0	0	0	0	Partridges.....	0	0	0	0	

WEEKLY CALENDAR.

Day of Month		Day of Week.	SEPTEMBER 1-7, 1870.			Average Temperature near London.			Rain in last 43 years.	Sun Rises.	Sun Sets.	Moon Rises.	Moon Sets.	Moon's Ago.	Clock after Sun.	Day of Year.		
			Day.	Night.	Mean.	Days.	m.	h.	m.	h.	m.	h.	Days.	m.	s.			
1	Th	Kidderminster Horticultural Show.	71.1	47.5	59.3	21	13	af 5	46	af 6	after.	43	af 9	6	0	6	244	
2	F		71.0	47.6	59.3	19	15	5	44	6	32	1	18	10	0	25	245	
3	S		71.8	47.7	59.2	19	16	5	42	6	46	2	1	11	8	0	44	246
4	SUN	12 SUNDAY AFTER TRINITY.	71.0	46.7	58.9	19	18	5	40	6	50	3	54	11	9	1	4	247
5	M		70.4	47.1	58.8	18	20	5	37	6	45	4	morn.	10	1	23	248	
6	TU	Crystal Palace Florists' Flower Show opens.	70.3	46.8	58.5	20	21	5	35	6	27	5	55	0	11	1	43	249
7	W	Royal Horticultural Society, Fruit, Floral, (and General Meeting).	70.3	47.5	58.9	19	23	5	32	6	0	6	3	2	12	2	4	250

From observations taken near London during the last forty-three years, the average day temperature of the week is 70.8°, and its night temperature 47.3°. The greatest heat was 91°, on the 7th, 1868; and the lowest cold 25°, on the 7th, 1856. The greatest fall of rain was 1.50 inch.

THE GENUS SAMBUCUS, OR ELDER.



EVERYONE is acquainted with the common Elder, Elder berry, or Boortree. Although a native of this country, it is but little valued, but some cultivate it in gardens or shrubberies for ornament, as well for its flowers and berries. The former yield by distillation Elder-flower water, and from the berries Elder wine is made. The flowers are white and yellow, in very large heads, and agreeably fragrant; and they are succeeded by purple or black berries in autumn. The foliage is little different from that of the Ash, but wanting its light shining green, otherwise the tree might be taken for a low-growing bold-foliaged Ash. It grows anywhere. From old associations, or some such cause, it is allowed a place near almost every homestead, particularly those with any pretension to age, but it is seldom planted, or if so only to a very limited extent.

To the gardener, however, the Elder, though common, is one of the most valuable of trees; I regret its valuable properties are not more appreciated. In the first place, it acts as a preventive and destroyer of insects. If a quantity of the leaves be put into as much water as will cover them, and boiled until it becomes quite black, the liquor, after having been strained and cooled, may be applied through a fine-rosed watering pot to trees or bushes infested with caterpillars. Poured over the nests of ants it will drive them away; and the fresh leaves put in the runs of moles will soon cause them to disappear. The Elder is also valuable on account of its succeeding where few other trees will grow. In the smoky atmosphere of towns it thrives admirably; it succeeds as well in a confined as in an open space; and near the sea, in places where there are no trees, it attains in a short time a degree of vigour which is quite surprising.

In towns and near the sea, great difficulty is experienced in getting anything to grow to afford shelter for more tender subjects. I was much struck with the screens of Elder which I recently saw near Sunderland. The points most exposed were sheltered by hedges or screens of Elder, and it was remarkable what growths they had made, and what a fine shelter they formed to the plants they enclosed. Rough-looking though these hedges were, yet where the growth of more trim hedge plants is very slow, and in many cases impracticable without some protection, the value of the Elder is considerable; for, besides growing better than anything else, it effects in two or three years all we look for from a hedge. Some fine screens 5 and 6 feet high had been formed in three years from the cuttings. The cuttings are put in after the leaves fall in autumn, the ripened wood of one or more years' growth being cut into lengths of about a foot, and inserted to within an inch or two of the top, the uppermost joint only being left above ground. From 9 inches to a foot is the distance they are put in at, and all the attention they require is to be kept clear of weeds. If watered a few times in summer with sewage, the growth the first year is wonder-

ful. In fact, three years only are required for a screen of Elder 6 feet high and as much through, where the Thorn and Privet in that time can hardly make headway, and do not grow more inches than the Elder does feet.

Useful as the Elder is in smoky town gardens and positions near the sea, it is as useful in shrubberies in more favourable situations, being one of the few low trees or shrubs that succeed under the shade and drip of large trees, so that it ought to be in every pleasure ground. There are varieties of it which cannot fail to please, and which are deserving of more extended cultivation. The most beautiful variety is, I think, the cut or Parsley-leaved Elder (*Sambucus nigra laciniata*), the foliage being finely divided, and the plant not so strong as the common Elder. It has a very elegant appearance: it is also of very free growth. There is a sub-variety of this with yellow-striped leaves, which is far more ornamental than many vaunted novelties. It is, however, more tender than the preceding, and does not do well in exposed positions. The white-variegated form of the species (*S. nigra foliis-argenteis*) is a good distinct variegated shrub, not so vigorous as the parent, nor so capable of enduring exposure, and the same remarks apply to the yellow-variegated kind, which, though very ornamental, has the disadvantage of not succeeding in cold situations, though the Elders thrive in all but very bleak positions.

Ornamental as all the preceding are by their foliage, flowers, and fruit, none of them can compare with the red-berried Elder, which I think is *Sambucus racemosa*, though I am not sure of the proper name of this species, but it is one of the finest of all flowering deciduous shrubs. In May it is one sheet of white, every shoot bearing large heads of bloom, at a distance not unlike those of the Snow-ball (*Viburnum Opulus*), but which, if more closely examined, are found to be of a greenish yellow, and they continue long in beauty. The flowers, however, constitute but a small part of the plant's attractions, for the berries are of the finest coral red, rendering the plant so conspicuous at a distance as to be quite a feature. So bright are the berries in colour that those of the Mountain Ash are dull beside them. The berries are produced in clusters or heads, like the flowers, and are of the brightest red or scarlet of any berry I know. Their full colour is attained about the middle of July, but at the beginning of August they are highly ornamental, and they continue so until late in the year. In the beauty of its berries it eclipses every shrub that I know, and here it is growing in a variety of positions—beside the rich purple of the Berberis, both sheltered and exposed, and under the shade of large Sycamore trees—in all of which it shows advantageously. To see it in perfection it should be grown in a mass in an open situation, but protected from northerly and easterly winds; but even where exposed to these winds it maintains its ground, where Cupressus Lawsoniana, Portugal Laurels, and Rhododendrons are severely injured, and it survives under trees where the Yew, the common Laurel, and the Portugal Laurel have failed.

In appearance it much resembles the common Elder, but is more shrubby and compact. In smoky towns and

near the sea it is quite at home, and must prove invaluable in such localities. There is a variety with white and another with purple berries. I believe it is a native of several parts of the south of Europe. Those who do not already possess it should next autumn add a mass of it to their shrubberies. It is not particular in regard to soil and situation, and is easy of propagation by cuttings of the ripe shoots and by seeds.

—G. ABBEY.

POT VINES.

THE economical value of pot Vines has often been called in question; indeed, I have often heard people say, "Grapes produced on pot Vines are never worth eating." It is quite true they are often very inferior, nor is it surprising that such should be the case. Badly grown and badly ripened canes are often fruited in pots; and frequently where no fault can be found with the Vines they are expected to bear far too many bunches, and are not half fed nor attended to during their growth.

Gardening must generally be considered a luxury except in the case of the commonest vegetables. Supposing the problem to solve be how to get Grapes when they are worth, say, from 7s. to 10s. a-pound in the market, I think it is a great question whether this cannot be done more cheaply by growing pot Vines than by forcing permanent ones; besides which, nothing is more beautiful than a pot Vine loaded with well-ripened fruit.

Having seen at Chatsworth last spring the best house of pot Vines I ever saw grown, I asked Mr. Speed to tell me how they had been managed. They were standing on a shelf covered with white spar, such as is brought out of the Derbyshire lead mines, consequently not a root had grown out of the pots. Every eye had been allowed to break and produce a shoot, and each shoot had made six leaves before being stopped. From the time leaves were produced, till the fruit began to colour, the Vines had never had water without guano in it, the plan being to give very weak doses constantly in place of stronger ones at longer intervals. A quantity of Peruvian guano broken small and passed through a fine sieve stood in a large pot, and the foreman put as much as his closed hand grasped into a large watering-pan each time he filled it. I have never weighed this quantity, but it must be a small amount to the gallon.

One thing struck me—that was the very careful way the watering was performed. The man had in his left hand a small wooden hammer with which each pot was struck, and if the sound produced did not indicate a want of water the plant was passed by. During the hot weather the pots were examined twice a-day, so that no plant could suffer from want of water, or receive it before it was required.

I should think the Vines carried on an average 8 lbs. of Grapes, and yet many of them had only four bunches, and none more than five, and they were as well coloured as one would wish to see. As the Vines were trained to meet in the centre of a narrow double-roofed house, and the leaves of the Vines just met all the way up, the whole roof was covered by foliage, and the crop looked a very heavy one. It was one of the prettiest sights I ever saw. Where less skill and attention can be bestowed on pot Vines, it is a question if they had not better be placed on a rich bed of soil and be allowed to root through; but as I never before saw so good a lot of pot Vines as these were, I thought some of your readers might like to know how they were cultivated.—J. R. PEARSON, *Chilwell*.

A FEW SUPERIOR BEDDING PLANTS.

I HAVE read with interest what your correspondent, Mr. Peach, and others have lately written in the Journal on bedding plants, especially Geraniums, and I have a wish to recommend to your readers two which are by far the best that I have ever tried or seen—namely, *Vesuvius* and *Glorious*, raised and sent out by the Messrs. Smith, of Dulwich.

I have tried all the most highly commended varieties sent out during the last twelve years, and these two are the most effective bedders that have ever come under my notice. Taking into consideration habit and wonderful productiveness of bloom, in combination with substance of petal as points of merit, they have no equals that I know of. For distant effect, *Vesuvius* in particular, from its lively shade of scarlet, is most valuable. Contrary to the habit of most Geraniums, the more they grow the more productive are they of their fine trusses of bloom, borne on stiff stalks. When forced in moist stoves in winter their blooming powers are most conspicuous, as they

throw up a truss from nearly every leaf. *Glow*, raised by the same firm, is also a good bedder, but compared to the two referred to only second-rate.

Imperial Blue Ageratum sent out this year I regard as one of the finest bedding plants introduced for many years. There are four beds of it here, and they are a perfect sheet of beautiful lavender, while its habit is all that can be wished. In the distance it is much more effective than *Viola cornuta* or *Lobelia speciosa*, while its habit is preferable to either of these. *Tropaeolum Cooperi* for a sheet of orange scarlet, and its adaptation for scroff work, has no equal that I know. Golden Feather *Pyrethrum*, so severely condemned by some, surpasses any of the golden-leaved Geraniums. If raised from seed it seldom blooms much the first year. It requires, like most bedding plants, liberal culture.—D. THOMSON, *Drumlairig*.

A TRIAL OF PEAS.

I ENCLOSE a statement of the results of a trial of Peas, mostly well-known sorts, thinking it may be interesting and useful to some of your readers to know how they have behaved in such a season as the past on a heavy soil in the cool moist valley of the Lea. The first two sorts were sown on the 11th of March, the remainder on the 23rd of March. They were hoed frequently, but never watered.

Sutton's Ringleader.—Sown March 11th; fit for use June 10th. Height, 2½ feet.

Sangster's No. 1.—Sown March 11th; fit for use June 12th. Height, 2½ feet. Pods rather larger than *Sutton's Ringleader*.

Mutton in Paro.—Sown March 23rd; fit for use June 16th. Height, 1 foot. Pods large and well filled.

Nutting's No. 1. Whisked Marrow.—Sown March 23rd; fit for use June 16th. Height, 15 inches.

Advancer (McLean's).—Sown March 23rd; fit for use June 23rd. Height, 2 feet. Long, well-filled pods, and good cropper.

Champion of England.—Sown March 23rd; fit for use June 25th. Height, 4½ feet. Heavy cropper; pods of good length and well filled.

Hundredfold.—Sown March 23rd; fit for use June 25th. Height, 4½ feet. Heavy cropper; pods large and well filled; hard, and of indifferent flavour.

McLean's Wonderful.—Sown March 23rd; fit for use June 25th. Height, 3 feet. Good cropper; pods of good length, but not well filled.

McLean's Dwarf Prolific.—Sown March 23rd; fit for use June 27th. Height, 3½ feet. Good cropper; pods of good length, but not quite full.

Cullingford's Champion.—Sown March 23rd; fit for use June 27th. Height, 4½ feet. Fair cropper, bearing most towards the top; pods of medium length, four or five peas in each.

Laxton's Supreme.—Sown March 23rd; fit for use June 27th. Height, 4 feet. Medium cropper; pods large, but not well filled.

Princess Royal.—Sown March 23rd; fit for use June 27th. Height, 3 feet. Heavy cropper; pods large and well filled.

Yorkshire Hero.—Sown March 23rd; fit for use June 28th. Height, 2½ feet. Fair cropper; pods of medium length, four or five peas in each.

Ne Plus Ultra.—Sown March 23rd; fit for use June 30th. Height, 5½ feet. Pods large and well filled, good cropper.

McLean's Premier.—Sown March 23rd; fit for use June 30th. Height, 3 feet. Pods of good length and well filled; a good cropper; fine flavour.

Veitch's Perfection.—Sown March 23rd; fit for use July 2nd. Height, 3 feet. Heavy cropper; pods of good length, and very well filled.

The Prince.—Sown March 23rd; fit for use July 3rd. Height, 3 feet. Good cropper; pods medium length, five or six peas in each.

British Queen.—Sown March 23rd; fit for use July 4th. Height, 6 feet. Good cropper; pods large and well filled.—WILLIAM PAUL, *Paul's Nurseries, Waltham Cross, N.*

LE BOTT'S HAND DRILL.—Among the helps to gardens which the ingenuity of inventors has placed within our reach, a good place must be given to the hand drill, which has been already highly recommended, but of which I had no experience until this season. One knows the sort of haphazard way in which seeds are too often sown, patches of plants coming up in one place, while there is a blank in another. Sometimes we see seed sown through a quill placed in the cork of a bottle containing the seed, but this is a poor way of endeavouring to counter-

act the evil. Now nothing can be more effective and handy than Mr. Le Butt's hand drill. The seed is sown evenly, and by the use of the brass collar the drill can be adjusted to any description of seed. I have found it very useful, and can recommend it to any who like efficiency and neatness in their gardens.—D., Deal.

GERANIUMS GROWN IN RUTLAND DURING 1870.

I HAVE tried many varieties, but find none better than the following:—

For Bedding.—Stella and Cybister, both do well here, especially the latter; Trentham Scarlet; Christine, rather too seedy this dry summer; Sutton's Scarlet Perfection, the very best scarlet bedder I have ever grown, being dwarf, compact and a free bloomer, with well-shaped flowers; Indian Yellow; Orange Nosegay; Monsieur Martin; Captain Daley; Admiration; Dr. Hogg, good, but goes to seed rather too much; Mr. Eyles; Hon. Gathorne Hardy, the best Nosegay Geranium I have grown; and International.

Double Geraniums.—Gloire de Nancy, Madame Rose Charmeux, Madame Lemoine, and Marie Lemoine, are all good bedders.

For Pot Culture or Vases.—Donald Beaton, Lord Derby, Chieftain, Commander-in-Chief, Marie Van Houtte, Clipper, Mrs. William Paul, and Monsieur Conner.—E. C., Oakham.

STRAWBERRIES WORTHY AND UNWORTHY OF CULTIVATION.

In the retained list of kinds (page 121) I notice the following:—Oscar, Myatt's Eliza, Goliath, Duc de Malakoff, Comte de Paris, and Ajax, all most uncertain croppers in this northern locality. I have tried each of them, but have long since discarded them. On the other hand, in the rejected list I notice Comte de Zans, Cornucopia, Excellente, Lecocq Pine, and Wonderful—kinds that I have grown for years, and I cannot recall an instance in which they have failed to give satisfaction to the grower.

Again, in the list of retained kinds, those stated to possess especial merit are marked with an asterisk. I notice a variety apparently considered unworthy of that distinction, which I think the best Strawberry I ever saw—namely, W. J. Nicholson. I saw a very fine plantation of this variety at Eglescliffe on the 11th of July, the quantity and size of the fruit being something wonderful for the season, and I was assured it was the first to ripen in any quantity there, having completely beaten kinds like Sir J. Paxton. Its habit is good, with nice bright green foliage; the fruit, sometimes wedge-shaped but generally conical, is very bright in colour, with rich, juicy, melting white flesh—in fact, I think this the best of any of the large-fruited varieties possessed of fine flavour that I ever saw, and those who have it not would do well to procure it at once.

I have seen another fine seedling, raised by M. Gloede, called James Veitch, which must, I think, prove an acquisition, though I have not tasted it. The fruit, however, is very large, and the plant appears to be a capital cropper.

The following are a few of the kinds I have noticed as generally doing well wherever I have seen them grown in the north—viz., Lucas, Cockscomb, Wonderful, Cornucopia (capital for preserving), La Constante, Comte de Zans, Ascot Pine Apple, W. J. Nicholson, Dr. Hogg, Mr. Radcliffe, President, and Sir J. Paxton.—J. W., *Middlesbrough-on-Tees*.

DIFFERENCES ABOUT ROSES.

MADAMEISSELLE MARIE RABY having been before the public since 1865, and universally acknowledged by all Rose-growers to be good, has at last been admitted by Mr. Radcliffe among the good Roses, as having been fully proved by him. I suppose in about two years' time we shall be told by the same authority that we may safely grow Madame la Baronne de Rothschild or La France. Some persons may prefer to try if even a scribbler's opinion be sound rather than wait for a fiat issued from Okeford Fitzpaine.—AN AMATEUR.

Cabbage plants three times in the season—say the first week in May, the first week in June, and the first week in July. The moth which lays the eggs will not light on the plants on account of the smell of the root, and the root is a good manure.—A CONSTANT READER.

THE ROYAL HORTICULTURAL SOCIETY. PROPOSED VISIT TO NOTTINGHAM.

THE Council of the Royal Horticultural Society having determined upon each year holding a summer exhibition in some important town in Great Britain, a meeting was held August 25th in the Mayor's parlour, at the Exchange, to take into consideration the desirability of forwarding an invitation from Nottingham for their first exhibition in 1871 to be held in that town. Lord Belper presided, and there were also present the Mayor, Mr. H. Sherbrooke, Mr. E. J. Lowe, Mr. J. L. Thackeray, Mr. J. H. Lee, Mr. R. Birkin, Mr. J. Barber, Mr. Ald. Herbert, the Rev. J. M. Valpy, Messrs. Chapman, Cann, the Rev. Samuel Reynolds Hole, Messrs. Armitage, Johnson (Town Clerk), Tarbotton, Starey, Ayres, Speed, of Chatsworth; Anderson, of Newstead; Pearson, of Chilwell; Cooling, of Derby; Caparn, of Newark; Gibbons, of Bramcote; Spencer, of Beeston; Edwards, of Nuttall; Fratingham, of Beeston; Cookson, of Carrington; Johnson, of Colwick; Read, of Pleasley Vale, &c. The following gentlemen, not being able to attend, sent their approval of the project:—Mr. Ingram, of Belvoir Castle; Mr. Lamb, of Colston Bassett; Mr. Tillery, of Welbeck; Mr. Henderson, of Thoresby; Mr. Miller, of Worksop Manor; Mr. Barton, of Oxtou; Mr. Cruikshank, of Kingston; Mr. Merryweather, of Southwell, and others. In opening the meeting,

His Lordship observed that no doubt those present were aware of the object which had brought them together. The Royal Horticultural Society had held its meetings in the country, but always at the same place and at the same time as the Royal Agricultural Society. He understood that now, however, they were of opinion that it would be more advantageous to hold a separate meeting, and some gentlemen believed that if there was an application from Nottingham it might be held there. The meeting was called for the purpose of considering the desirability of sending an invitation, and as Mr. Lowe would be prepared to state all particulars, he should at once call upon him to do so. (Hear, hear.)

Mr. Lowe remarked that he had received a number of letters from different persons who were unfortunately absent from the meeting, amongst others from Earl Manvers, who was at the Isle of Wight, but who would have been glad to have attended and given his cordial support. Sir Henry Bromley had also written, but as his train did not arrive until ten minutes to twelve o'clock they could not expect him there at eleven o'clock. Sir Henry expressed himself very anxious that they should get the Society to hold its meeting at Nottingham; and added that he should like to see an artisans' prize cup worth ten guineas, towards which object he should wish to give five guineas himself. (Hear, hear.) He had had letters also from the Mayor of Newark and others, but he would not detain the meeting by reading them. As Lord Belper had said, the Royal Horticultural Society had for the last four years gone into the provinces once a year with the Agricultural Society, but it had now increased so much in importance that it felt that it ought no longer to play second fiddle to any other society. It had therefore determined upon holding a show by itself in some town not then frequented by the Royal Agricultural Society. Hearing of this he spoke to some of the members of the Council, and asked if Nottingham sent a proper invitation whether there would be any chance of success in obtaining the first independent meeting of the Royal Horticultural Society there. To that question he received a very favourable reply, and he believed that, though there were other towns in the field, they stood a better chance than any other. (Hear, hear.) He next wrote to the Secretary of the Horticultural Society to inquire the conditions on which they would come, and received this reply:—"I am favoured with your letter of the 4th inst., and, in reply, beg to inform you that the sum required as a guarantee fund is £700 when the Royal Horticultural Society is visiting the provinces, and the following will give you an idea of the amounts collected for special prizes in the towns visited by the Society—viz., at Bury St. Edmunds we offered £423 1s., they collected £238 6s. 6d.; at Leicester we offered £478 10s. 6d., they collected £362; at Manchester, we offered £497 16s. 6d., they collected £394 9s.; at Oxford we offered £510 6s., they collected £251 0s. 6d." From this it appeared that the prize

AVOIDING CABBAGE CATERPILLARS.—A correspondent lately asked how to keep caterpillars from Cabbages. I have found it a good plan to sow a little dry root between the rows of

list of the Society had gradually risen from £400 to £500, whilst the local subscription list had been from £250 to £390. With regard to the local list, he thought the sum was so small, that when spread over so large an area there could be no difficulty in getting it; and with respect to the £700 required as a guarantee fund, when they considered the importance of the exhibition, and the fact that it was kept open for four days, they would see that there was little, if any, of that money really needed. He believed none was required at Manchester, and he did not know what would be required at Oxford this year. Such a show as the Royal Horticultural Society's now was Nottingham had not yet witnessed. Two years ago the Society held a meeting with the Agricultural Society at Leicester, but that was at a time when plants were out of their glory. When the Society came forth into the provinces when plants were just in perfection, he was not exaggerating if he said that the show would be one which if once seen would never be forgotten. He was a strong advocate for Nottingham to receive the Horticultural Society, for he thought it would be a great honour for them to get the first independent meeting of the Society held here. He hoped they should succeed in doing so. (Applause).

Mr. Thackeray moved "that the present meeting considers it desirable to invite the Royal Horticultural Society to hold their great provincial flower show in Nottingham in 1871, and that the Lord-Lieutenant, as chairman, be requested to communicate this wish to the President of that Society." He considered that it would be a great honour if they could get the Society to hold its meeting there. He had no doubt as to its financial success, and should have no objection to becoming one of the guarantors, so confident did he feel on the subject. There were few towns where the artisan class were greater cultivators of flowers than in Nottingham, and it would be a means of great instruction, as well as a treat, to them to inspect the show of such a Society. As regarded the site, he thought the best place would be the Arboretum; and he did not see any difficulty in setting it apart for such an occasion. (Hear, hear.)

Mr. Lee seconded the resolution, and said he sincerely trusted that the application to the Society might be successful.—The motion was carried unanimously.

Mr. Barber said he supported the movement which had been started. Like all other movements, however, it required the sinews of war. As Mr. Lowe had explained, the amount of subscription required was not very large, and he thought there would be no difficulty in getting the necessary fund. Besides the subscription, a guarantee fund of £700 was required to be raised, and should any portion be needed, those gentlemen who guaranteed the money would be called on *pro rata*, according to the amount of their guarantee. In some cases no portion of the money was required, as for instance, at Manchester. He begged to move "That a guarantee and local subscription list be at once commenced, as an evidence that Nottingham is prepared to give the Royal Horticultural Society a proper reception." (Hear, hear.)

Mr. Starey seconded the motion, and remarked that the show would be a means of pleasure to a great many in the neighbourhood who were fond of horticultural pursuits. The amount required was very little when spread over the town and county, and if they all did a little towards it, there would not be the slightest difficulty in obtaining it. For his own part, he could only say that he should be very pleased to assist. (Hear, hear.)

The motion was carried *nem. dis.*

Mr. Leivers proposed that a committee be formed, consisting of the Mayor, chairman; Mr. J. Smith Wright, treasurer; and Mr. Lowe, secretary, together with Mr. Sherbrooke, Mr. Milward, Mr. Edge, Mr. Seely, M.P., Mr. Smith, M.P., Mr. Akroyd, Mr. Newton, Rev. S. R. Hole, Dr. Robertson, Sir H. Bromley, Messrs. Windley, Birkin, jun., Forman, Farmer, Shilton, Knight, Day, Gadd, Ingram, Speed, Cruickshank, Pearson, Evans, Henderson, Tillery, and Lamb, with power to add to their number; also that the Mayors of Derby, Leicester, Grantham, Retford, and Newark be invited to form district committees, to co-operate with that at Nottingham.

Mr. Goodall seconded the motion, and it was carried.

The assemblage, presided over by the Lord-Lieutenant (Lord Belper) was a most respectable one, representing all classes, and with a large sprinkling of the practical gardening element. Nothing could have been more unanimous than the tone of the meeting. Every person seemed willing and anxious to do all that he could, and the offers of material support were such as to leave nothing to be desired. One special feature may be noted, and that was, Sir Henry Bromley, who was unable to

get to the meeting in proper time, suggested that a ten-guinea cup should be given to artisans for Roses, to which he offered to subscribe five guineas. This is a very good beginning, and in the right direction, and though it was not announced at the meeting, we have reason to know that, should the exhibition be held here, Lord Belper has promised twenty guineas towards the special prizes. We therefore think it is only necessary for us to make a united effort, and success is certain to crown it. Other towns, York, Manchester, and Leeds, are competing against us; but there is no doubt the Council will recollect that these towns for years past have had their large flower shows, while in this locality a really first-class show would be an entire novelty, and hence we assert the chances of complete success are greater here than they can be in any place where large flower shows are common. Then, as a gardening centre, there is no town in England that can compare with our own. Every second man you meet, whether dressed in fustian or fine linen, is a gardener, and many of them cultivators of superior skill. Where great flower shows are common, success cannot be so certain as where there is novelty added to the attraction; and here, anything really great, such as the Royal Horticultural Society could place before the visitors, would be something that must command success.—(Nottinghamshire Guardian.)

BLOOMING GLOXINIA SEEDLINGS.

LET me add, as a corollary to Mr. Luckhurst's article on Gloxinias, that where there is a stove, or even, I should imagine, any kind of forcing pit, there is not the slightest occasion to keep Gloxinia seedlings for twelve months before blooming them. On the 28th March last I sowed a pan of Gloxinia seed, which produced many hundreds of seedlings. At our flower show on July 10th I had two of these in bloom, and since then I have had scores in fine bloom and in endless variety. All that was done was to give them one or two shifts and bring them on in the Cucumber house. I came to the conclusion that the Gloxinia was the most satisfactory florists' flower to raise from seed that I had ever sown.—ALFRED O. WALKER.

PICKING AND MARKETING FRUIT.

NOTHING adds so much to the profits of fruit culture as a good system of picking and marketing. Often a single shipment of Strawberries will vary from 40 to 100 dols. in price, according to the neatness of the appearance of the fruit, its quality, and its condition.

Josiah Hoopes, in the *Delaware Republican*, in a series of articles on fruit culture, gives many judicious hints on this important subject. In regard to the gathering of ripe fruits of different kinds, he says that no fruit should be taken from the tree or plant during a damp time, and especially when the dew is plentiful in early morning. Each specimen should be taken from the tree one by one, handled as if they had been so many eggs. The slightest bruise or even abrasion of the skin is the sure forerunner of a dark spot, which will eventually change into some form of rot. The spores or seed of fungi are always ready to assist in the work of dissolution, and the slightest scratch gives them a foothold for their destructive work. Scarcely any varieties of the largest fruits colour and ripen so well if left to perfect themselves on the tree, and especially is this true in respect to Pears. Summer varieties, as they approach maturity, loosen their hold somewhat on the limb, and by gently raising the fruit they will easily detach themselves at the proper period. This is an excellent test, and may always be relied on. To colour up fruit nicely, all that is necessary will be to spread a blanket on the floor of a cool room, and then thinly and evenly place the fruit on the floor. A second blanket must be spread over them, and in a short time the effect of this treatment will be apparent. Pears perfected in this manner rarely have the meanness of their naturally-ripened companions; nor do they prematurely decay at the core as when left on the tree. Peaches are too frequently gathered before attaining full size, and when this is the case we need not expect good flavour. They must obtain this requisite before gathering; although it is not necessary to delay picking until very mellow. As a general rule, all small fruits are gathered too early; and, as high colour is not a sign of maturity, many experienced fruit growers are frequently misled. Never pick Strawberries because they are red, nor Blackberries solely on account of their dark appearance. Each should remain on the plant for some time thereafter. Straw-

berries picked with the calyx adhering will always carry better and be less liable to decay than if carelessly pulled off without this appendage. And so with Cherries also, as the cavities made by parting with their stalks are liable to engender speedy decay. Neither do they present so fine an appearance on the table, or in the fruit baskets of our market gardeners as when temptingly displayed, each with its stalk attached. The foregoing remarks in relation to the proper time for gathering fruits are equally applicable to Grapes. These generally colour long before they are mature; and thus many a novice in fruit culture frequently forms an unjust opinion of his varieties simply from testing unripened specimens. Grapes should always be severed from the Vine with strong scissors or trimming-shears, and never twisted or broken off.—(*Horticulturist*)

MELONS IN A GROUND VINERY.

AFTER raising some plants in a warm orchard house, I placed them under a ground vinery, without any bottom heat. There were three sorts, all sown on the same day—Windsor Prize, Beechwood (for which I have to thank you), and Achopnesor-rischer. Windsor ripened on the 6th of August, and Beechwood on the 13th. Both sorts are now finished. The third sort, which is said to grow out of doors on a ridge, has not yet ripened; so under glass it seems to have no advantage over sorts which are reputed more tender. In former years I have ripened it in warmth, and found it of good flavour, though coarse in appearance.

An American correspondent of yours once stated that no soil succeeded so well as virgin forest mould. This, I presume, means leaf mould and sand. Now, in England we prefer stiffer soil: so, to decide the question, I filled a Sea-kale pot with an imitation of forest mould mixed with pieces of broken brick, as better than stones, while a similar pot was filled with a mixture of the same soil with loam. Into each pot was put a plant of Windsor Prize. The plant in light soil was always thirsty, and produced but one fruit weighing 2 lbs. 2 ozs. The heaviest fruit on the other weighed 4 lbs. 11 ozs.

In cutting open a Beechwood to-day, and very excellent it was, I could not help contemplating the enormous number of its seeds, yet most of these seeds were probably fertilised, and only by a touch of a male flower to the stigma. What, then, must not be the minuteness of each grain of pollen, and how marvellous its active power!—G. S.

P.S.—Though the ground-vinery system succeeds perfectly in fine summers like 1868 and 1870, it did not succeed in 1869.

MY GARDEN PLUM ORCHARD.

So many of my friends who have seen my little Plum trees in growth have written to know more about their different qualities, that I have thought it best to send a few notes to "our Journal," so that all may read, as it were, from one letter. At the same time I have thought it might interest others unknown to me, and who are about to plant. I consider my fruit trees in many cases as trees of ornament as well as utility, and therefore plant many of them among my shrubs, where they all thrive exceedingly well, and not only are beautiful in the spring when in bloom, but give a rich colouring effect in the autumn when in fruit. But there are some at least that I would not advise to be so planted, and they are all the Green Gage tribe, for the bullfinches will assuredly peck out all the bloom buds and spoil the trees. There are, however, many others, Plums as well as Pears, which do well; and at this time of the year, when flowers are scarce, my fruit trees are the chief attraction to my visitors. I do not pretend to go into the minutiae of every kind, but to give a general outline as to their qualities as grown here. Those wishing to know more I would advise to consult that very excellent work, Dr. Hogg's "Fruit Manual," a book which no pomologist ought to be without. As I attend to all my Plum trees entirely myself, I have the opportunity of judging pretty correctly as to their qualities as regards the summer-pruning system, brought into notice by Mr. Rivers, of Sawbridgeworth, and to whom amateur fruit-growers are indebted for much instruction, knowledge, and pleasure.

I give below a few notes of some of the sorts of Plums which have already ripened with me, and if thought worth while I will send more as others come to maturity, as I have many yet in full growth, some of which are especial favourites of almost every one, though grown under different circumstances than as out-door pyramids and bushes. I may here remark that, as a

rule, I find the Gage tribe less adapted for pyramids than bushes, as some are difficult to keep in form. Several of my trees did marvels this year. In the way of crop I have one little bush of the Mirabelle Plum, just 1 foot high, that has twenty-one Plums on it; I merely retained the quantity just to see how many it would carry.

Early Mirabelle.—This Plum was the first of my earliest to ripen. It is a small round fruit of a light greenish yellow, slightly tinted with red on the sunny side, and covered with a thin grey bloom; the flavour, if I may use the expression, is bright, sweet, and delicious. I gathered the first fruit on July 22nd. It is an excellent bearer, and makes a good pyramid or bush.

Early Rivers is a first-class variety as regards cropping. For the last two years the quantity has been wonderful. The fruit is of a deep purple, covered with a thick grey bloom. It is oval in form, and when suffered to hang long on the tree has a fine vinous flavour. It makes an excellent pyramid or bush; the fruit was ripe July 29th.

St. Etienne very much resembles the Early Mirabelle in form and colour, but is rather larger. It does not hang quite so well, nor is it of quite so good a flavour. It makes a good pyramid. The fruit was gathered on July 30th.

Early Orleans is a second-class Plum, an excellent bearer, but better adapted for a bush than a pyramid. The fruit is too well known to need description.

Devonshire's Superb is a fine, large, rich Plum, of a bright yellow colour, slightly tinted with purplish red, and spotted on the sunny side. It is vigorous in growth, but its branches are apt to die from no seeming cause. It makes a large pyramid, but is rather a shy bearer.

Red Morocco is a fine, large, culinary Plum of a deep bright red colour, almost purple; in form it is a long oval, and rather more narrow at one end. The flesh is firm, and it preserves well. It is best kept as a bush. It was gathered August 10th.

De Montfort is a very rich, sugary, delicious Plum, above the medium size, oval in shape, and of a deep purple, streaked with a lighter colour and brown. It is a very fair bearer, and is well worth growing either as a pyramid or bush. It was gathered August 15th. If allowed to hang until it shivers it makes a perfect sweetmeat.

Prince Englebert makes a noble pyramid, and, when the fruit on it is ripe, has a fine appearance, it being of deep purple colour, covered with a beautiful blue bloom. The fruit is large, long oval in form, and when quite ripe is delicious. It is strong in constitution, an excellent bearer, and is well worth cultivating. It was gathered August 18th.

The Orleans is a well-known Plum. It bears well and makes a good pyramid or bush. It was gathered August 26th.

Peach Plum.—This is large and delicious, of excellent quality; but with me it is a bad grower, dying-back continually, although a good bearer. I am afraid I must give it up for that reason.

Mirabelle is a small round Plum, of a deep bright yellow colour covered with dots. It is of good flavour, though rather mealy at times. It is an excellent bearer, makes a very compact and healthy pyramid, and might be grown as an ornamental tree if considered needful. With most it is a great favourite.

Of these I would select for pyramid growth, the Early Mirabelle, Early Rivers, De Montfort, Prince Englebert, Orleans, and Mirabelle.—HARRISON WELB, *Weirleigh, Kent*.

METROPOLITAN SOCIETY'S EXHIBITION AT THE CRYSTAL PALACE.

I AM glad to say, that notwithstanding the very unfavourable character of the season for florists' flowers, there is every probability of a good exhibition. The following gentlemen have kindly consented to act as Judges:—For Dahlias: Mr. Charles Turner, Slough; Mr. Richard Dean, Ealing; Mr. W. Holmes, Hackney. For Hollyhocks and Gladiolus: Mr. John Standish, Ascot; Mr. J. Fraser, Lea Bridge; Mr. Kinghorn, Richmond. For Asters, Verbenas, and Roses: The Rev. Cleaver Peach, Appleton-le-Street; Mr. Lidgard, Hammersmith; and Mr. Cutbush, Highgate. For baskets of cut flowers: W. Thomson, Esq., Penge.—D., *Deal*.

MESSRS. WEEKS & CO.'S PATENT DUPLEX BOILER.—We are informed that this is now in regular work at W. Leaf, Esq.'s, Park Hill, Streatham. If it fulfils all that is stated relative to

its advantages, it will be what Messrs. Weeks assert it is, "the best," but continued use can best decide that.

BRADFORD ANNUAL GOOSEBERRY SHOW.

This was held at the Junction Inn, Manningham, near Bradford Yorkshire, on August 29th.

			dwts.	grs
Robert Pettey.....	Twiss	Dan's Mistake.....	37	0
John Firth.....	do.	Leveller.....	41	13
Joseph Backhouse..	do.	Plunder.....	34	4
William Willans ..	do.	Careless.....	30	1
Jonathan Firth....	Premier prize.	High Sheriff.....	25	15
Robert Pettey.....	Stewards' prize	Bolling Hall.....	25	0
John Firth.....	do.	Leveller.....	22	18
William Raistrick..	do.	London City.....	21	4
Joseph Backhouse..	do.	Careless.....	20	15
Isaac Normington..	do.	London.....	22	21
Thomas Windle.....	do.	Trumpeter.....	19	3
William Willans ..	do.	Stockwell.....	20	0

RED.

Jonathan Firth.....	London.....	24	13
John Firth.....	England.....	23	11
John Firth.....	Companion.....	22	23
Jonathan Firth.....	Clayton.....	22	17
Robert Pettey.....	Talfourd.....	22	10
Isaac Normington..	John Anderson.....	20	13
Robert Pettey.....	Duke of Sutherland ..	21	0
William Willans ..	Bolling Hall.....	20	10

YELLOW.

John Firth.....	Leveller.....	24	8
John Firth.....	Ringer.....	21	15
Joseph Backhouse..	Mount Pleasant.....	20	20
Jonathan Firth.....	Kitley.....	20	9
William Raistrick..	Drill.....	20	7
Jonathan Firth.....	High Sheriff.....	19	11
Thomas Windle.....	Mr. Whitaker.....	19	10
William Raistrick..	Catherina.....	19	9

GREEN.

Robert Pettey.....	Stockwell.....	22	22
John Firth.....	Plunder.....	21	15
William Raistrick..	Telegraph.....	20	19
John Firth.....	Hospool.....	20	12
William Raistrick..	Surprise.....	19	15
Jonathan Firth.....	Rough Green.....	19	3
Thomas Windle.....	Express.....	18	18
Thomas Windle.....	Thumper.....	18	21

WHITE.

John Firth.....	Postman.....	24	12
Joseph Backhouse..	Careless.....	21	17
Thomas Windle.....	Elizabeth.....	20	22
Jonathan Firth.....	Antagonist.....	20	15
Joseph Backhouse..	Mitro.....	20	3
William Willans ..	Lady Stanley.....	19	22
William Raistrick..	Freedom.....	19	0
Jonathan Firth.....	Pebo.....	18	8

Mr. John Emmott, Judge and Weigher.

The above were all grown in the immediate neighbourhood of one of the largest manufacturing towns in Yorkshire.

JUDGES DISQUALIFYING PELARGONIUMS.

WERE the Judges of a flower show right in disqualifying anyone for exhibiting the blooms of Le Grand, Stella, Lord Palmerston, and Cybister as single Zonals?—H. A., *Newick*.

[Much will depend on the wording of the schedule. All the varieties you name are Nosegays, and do not belong to the Zonal section. We should therefore say any judge would rightly disqualify in your case if the class was for Zonals only. Most schedules in the present day give distinct classes for Nosegays and Zonals.—W.]

CHARRING REFUSE.

To make room for Mushroom beds out of doors I had to get rid of a huge mass of woody rubbish, chiefly cuttings and prunings that were small, averaging from one-eighth to one-quarter-inch diameter, some being with and some without leaves. I could soon have burned the whole into a few barrowloads of ashes, but I did not wish to waste it so; and therefore I set apart a day, and had all charred in the simple mode recently described (vol. xviii., page 304). I have thus easily obtained from two to three cartloads of charred refuse; the half, or rather more perhaps, will be fine rough charcoal dust, so useful

for cuttings; and the other will be small hills of charred wood of the sizes above indicated, which we can again separate into different sizes by means of a sieve. Now the quantity is entirely owing to making heaps of the rubbish rather small, and pulling it out as soon as charred. Even the dampish litter placed on the top was well charred. In every department I shall find this most useful. Had I attempted to char this heap of rubbish in the usual way the great bulk, in spite of every care, would have gone to ashes, which would have been chiefly valuable for the alkalies they contained. Now the finest charred dust will be very useful for cuttings, seed-covering, &c., and the larger for potting and drainage, making many a compost sweet and porous that might have been the reverse.—R. FISH.

[Of the two or three cartloads Mr. Fish has just made he has sent us a sample, and though he tells us that there are larger pieces in the heap and more dust in others, we can clearly perceive how useful such small stuff is.—Eds.]

OUR SALAD HERBS.

THERE is perhaps no country in the world so rich as England in native materials for salad-making, and none in which ignorance and prejudice have more restricted their employment. At every season of the year the peasant may cull from the field and hedgerow wholesome herbs which would impart a pleasant variety to his monotonous meal, and save his store of Potatoes from premature exhaustion; and there can be no question that in hot seasons a judicious admixture of fresh green food is as salutary as it is agreeable. Much has been said lately about the advantage which the labouring man would derive from an accurate acquaintance with the various sorts of Fungus, and he has been gravely told that the *Fistulina hepatica* is an admirable substitute for beefsteak, and the *Agaricus gambosus* for the equally unknown veal cutlet. But deep-rooted suspicion is not easily eradicated, and there will always be a certain amount of hazard in dealing with a class of products in which the distinctions between noxious and innocuous are not very clearly marked. There is not this difficulty with regard to salad herbs, and we conceive that the diffusion of a little knowledge as to their properties and value would be an unmixed benefit to our rural population.

The first place must be assigned, on the score of antiquity, to the Sorrel plant (*Rumex acetosa*), which in some districts still preserves the name of "green sauce," assigned to it in early times when it formed almost the only dinner vegetable. Its acid is pleasant and wholesome, and more delicate in flavour than that of the Wood Sorrel (*Oxalis Acetosella*), which, however, is used for table purposes in France and Germany. Chervil (*Anthriscus Cerefolium*) is often found in a wild state, and is an admirable addition to the salad bowl; and it is unnecessary to enlarge upon the virtues of Celery (*Apium graveolens*) when improved by cultivation. John Ray, writing in 1663, says that "The Italians use several herbs for sallets which are not yet, or have not been used lately, but in England—viz., Selleri, which is nothing else but the Sweet Smallage; the young shoots whereof, with a little of the head of the root cut off, they eat raw with oil and pepper;" and to this we may add that the Alexander (*Smyrnum Olusatrum*) is no bad substitute for its better-known congener. The Dandelion, which in France is blanched for the purpose, affords that *amari aliquid* which the professed salad-maker finds in the leaves of the Endive, and the same essential ingredient may be supplied by the Avena (*Geum urbanum*), the Bladder Campion (*Silene inflata*), and the tender shoots of the wild Hop. Most people are familiar with the properties of the Water Cress (*Nasturtium officinale*), and the Garlic Hedge Mustard (*Erysimum Alliaria*); but it may not be generally known that the common Shepherd's Purse (*Capsella bursa-pastoris*) and Lady's Smock (*Cardamine pratensis*) are pleasant additions, whose merits have long been recognised by our foreign neighbours. In fact, there is scarcely a herb that grows which has not some culinary virtue in a French peasant's eyes. Out of the blanched shoots of the wild Chicory (*Chicorium Intybus*), he forms the well-known *barbe de Capucin*, and dignifies with the title of *salade de Charvine* our own neglected Corn Salad (*Pedia olitoria*). It would be very easy to extend the dimensions of our list of native salad herbs, for there are, perhaps, some palates to which the strong flavours of the Chive (*Allium Schoenoprasum*) and Stonecrop (*Sedum reflexum*) may commend themselves, but enough has been said to show that Nature has not dealt niggardly with us, and that only knowledge is needful to make

the riches she offers available. If the British peasant can be taught to discover hidden virtues in these plants with whose outward forms he has had a life-long familiarity, we do not despair of his acquiring the one secret of salad-making—viz., the judicious employment of oil so as to correct the acid juices of the plants and yet preserve their several flavours unimpaired.—C. J. ROBINSON.—(Nature)

GRAPES NOT COLOURING AND SHANKING.

I HAVE a span-roofed house with glass all round to about 3 feet from the floor, and with an inside border. The bottom is concreted and drained with pipes; on this is nearly a foot of broken bricks, &c., for drainage, and on the latter about 2 feet 9 inches of decayed turf, with layers of old wall plaster and mortar. In this material the roots are planted. The Vines are five years old; they were started this year in the middle of January, therefore the fruit is overripe. For the last two years the Grapes have not coloured well, and several of the bunches have some shanked berries upon them; I am satisfied with their size (between 2 lbs. and 3 lbs. per bunch), and the berries are fine. I am afraid there is some improper treatment on my part. From their starting the Vines have been constantly watered up to the first week in July, since which time they have not been watered, but they have since then thrown out fresh shoots, producing fresh bunches of Grapes. The foliage is large and healthy when I expected the sap to have been drying and the root action ceased. Did I use water too abundantly, and for too long a time? or is the bottom and material for the roots wrongly constructed? or has the soil become too dense from the watering and wants now renewing?—J. H.

[We think the chief faults have been overcropping and over-watering. The Vines seem to be in such a thriving fertile condition that we would not care to renew the soil, but it would be well to have a few trial holes, so as to know the state of the border generally before heavy waterings.—EDS.]

THE AMATEUR GARDENER.

(CHAPTERS NOT IN WALTON.)

No. 4.

HORTATOR.—Now then, my friends, permit me to present you to the queen of flowers, for this bright day of June is one of her majesty's most joyous levées.

CLERICUS.—Are there no kings or prince consorts to support the royal dignity?

SYLVIA.—Indeed there are many. For instance, surely this deep crimson Charles Lefebvre is a worthy consort to Coupe d'Hébe; especially, too, as the beauty of the latter does not extend much beyond midsummer, and so is a true type of the brief existence of feminine charms.

CVIS.—Had such a remark come from masculine lips I should have been tempted to question its soundness, for the calm gentle expression of feminine loveliness in old age has to me peculiar fascination.

CLERICUS.—These are indeed lovely Roses! They are, I perceive, principally dwarfs and pillars. But where are your standards?

HORTATOR.—Conspicuous by their absence! Probably you may greatly question my taste when I tell you that I have an invincible hatred of them.

SYLVIA.—Shared by myself, if Hortator would modify his strong expression by the substitution of objection for hatred, for I can't admit such a word in connection with Roses.

CVIS.—What may be the grounds of your strong dislike, Hortator?

HORTATOR.—Principally their ugliness—a very decided word this, notwithstanding Sylvia's reproof, for standard Roses always remind me of the beautiful princess's head upon the red republican's pike in the great French revolution.

SYLVIA.—Or a less frightful simile, and quite as appropriate, would be "long broomsicks with a flaunting head-dress."

CVIS.—You modified your objection by the word principally. What are the other objections?

HORTATOR.—Many, one of which is their short-livedness; a second, their throwing up shoots here, there, and everywhere, so that they require constant watching; a third, that they require peculiar soil to suit them; another, that they are often partially destroyed by frost, so that while one side of the head is strong and vigorous the other is weak and feeble, and in

severe frosts the head is frequently destroyed altogether, and then your Rose is gone; whereas, if the heads of Roses on their own roots be killed it is seldom that the roots themselves are, so that they push forth again in spring with little abated vigour.

CLERICUS.—But are there not dwarf Roses budded, or "worked," as I believe they are called, upon foreign stocks?

HORTATOR.—You mean upon the Manetti stock. Yes, and they are far less objectionable than the Briar, as, if properly planted, they throw up only a few shoots; but they are frequently difficult to distinguish from the true branch. The only possible defence I can imagine to be made for standard Roses is the ease with which they may be procured, accounted for readily by the rapidity with which they are budded and sent out for sale. Pillar Roses like this [pointing to a specimen of the Duchess of Sutherland] certainly take some time to raise to this height and state of perfection.

CVIS.—It is indeed magnificent! One mass of flower from the top to the very bottom. But surely there must be much art required to reach such perfection as this.

SYLVIA.—No art at all, simple judicious training and pruning, which observation of the habit and growth of the Rose will soon enable anyone who loves flowers to do for himself. I always think if Roses must be invested with royalty that I would have kings, queens, and princesses; all the dark ones should be kings—Charles Lefebvre, by-the-by, should be emperor—the reds and yellows queens, and the Tea-scented a family of princesses.

HORTATOR.—If Charles Lefebvre be an emperor, then surely Maréchal Niel, notwithstanding the masculine name, should be empress; never was there a greater misnomer than to give such a name to such a Rose.

CLERICUS.—What a lovely Rose is the Cloth of Gold. I know but little about Roses, but my eyes were almost dazzled by the sight of this in the garden of the old Bi-hop's palace at Wells. The gardener there told me that he had cut eight hundred blooms from that tree in one season! It covers a large space on the ruined stone wall of that venerable pile. He told me, too, what seemed to surprise him much, that he had in vain endeavoured to coax Maréchal Niel into bloom; indeed, that he had lost three plants in succession in the winter, but that he was now going to try it on its own roots.

HORTATOR.—And will, doubtless, succeed.

CVIS.—Pray tell me, Hortator, what gardens that are accessible are most worth seeing.

HORTATOR.—That is a wide question, but those that at once strike me are—Chatsworth (the Duke of Devonshire's, in Derbyshire); Treutham (the Duke of Sutherland's in Staffordshire); Enville (the Earl of Stamford's, in the same county); and Deepdene (Mrs. Hope's, near Dorking, in Surrey). The latter is unique in its way, which is attributable to nature rather than art, though art has greatly assisted in making it one of the most classical gardens in the kingdom.

CLERICUS.—It always seems to me a matter of regret that in such gardens, where the owners so kindly admit the public, some uniform plan of payment for the privilege is not adopted, instead of leaving it to individuals to fee the gardeners. Not knowing whether we have paid sufficient to satisfy them, or may be, that we have overpaid, thus inflicting an injustice upon other visitors, appears to me most objectionable.

HORTATOR.—True, indeed, and did I possess such gardens I should adopt a plan that I think all would be satisfied with, and which would be a great help to any neighbouring local charity. I would have printed tickets admitting a single person at 1s., and others at 2s. 6d. admitting a party of four, stating distinctly for what purpose the proceeds would be applied, and also that further fees were strictly prohibited. Certain days might be mentioned when the gardens would be accessible, and the expense of the man (he need not be a gardener, thus avoiding the inconvenience of the interruption of the work), might be deducted from the amount. Were this plan adopted at such a place as Enville, where visitors may frequently be counted by hundreds in a day, the help to any neighbouring hospital would be material.

CLERICUS.—An excellent idea. What would I give for such aid to my parochial institution.

CVIS.—But this is a digression from the great Rose question. Pray tell me the names of those you would recommend me to purchase, for I perceive, like the family human, though they resemble each other in general features, yet they differ materially on closer contact.

HORTATOR.—Well, I shall indeed be very glad to furnish

you with a list which I could recommend, but it would take me some little time to make the selection, which I will, therefore, defer until we have a longer time to discuss the subject as I suggested, and you will not want to send in your order before October at least.—HORTATOR.

BOXES FOR HOLDING USUAL MEASURES.

THE following table will be found valuable to many of our readers:—A box 24 inches by 16 inches square, and 28 inches deep, will contain a barrel. A box 26 inches by 15½ inches square, and 8 inches deep, will contain a bushel. A box 12 inches by 11½ inches square, and 9 inches deep, will contain half a bushel. A box 8 inches by 8 inches square, and 8 inches deep will contain a peck. A box 8 inches by 8 inches square, and 4½ inches deep, will contain one gallon. A box 7 inches by 8 inches square, and 4½ inches deep will contain half a gallon. A box 4 inches by 4 inches square, and 4½ inches deep, will contain a pint.—(*English Mechanic.*)

ABOUT THE LAND'S END.

“PENZANCE, eight or fifteen days for 24s.” “Yes, that will do.” Away, then, last Saturday morning at six o'clock in my good friend's trap to Paddington. London is scarcely up, inns and cab horses have a dissipated appearance, and stale odours taint even the early summer morning. Now we skirt the park, and a fringe of jewel-like beds, all set in emerald velvet, glow fresh and beautiful in the morning sun. But the pleasant picture disappears, and nothing reminds us of country life but milk cans and market carts, the latter laden heavily with all good things.

Paddington is reached; there is an awful crush for tickets, and at eight we are off on what turns out to be a long and for the most part tedious ride of fifteen hours. To the traveller for the first time, however, the rail from Dawlish to Penzance is interesting on account of the enormous engineering difficulties overcome by the genius of Brunel, and the very beautiful scenery along the line. At last we reach Penzance, and grope our way in search of an inn, whence we shortly remove into lodgings on the Parade—cheap, clean, and comfortable at—. No, I do not write to advertise, but to tell something of the Ferns, flowers, and fancies of this delightful county.

We consulted a borrowed copy of Murray as the best guide, in some respects, as to what to avoid. For instance, in the cave where the Maiden-Lair Fern grows so luxuriantly, who would expect to find a frond? Have not the Vandals spoiled it so that only a few tiny plants hide timidly, high out of reach, under the friendly shade of grasses and Briars? Let would-be botanists who begrudge the time and toil for honest search go away disappointed. We started westward early on Monday, soon reached the picturesque but unsavoury Newlyn, and under the grey rocks in the crevices of Tol, found our first frond of *Asplenium lanceolatum*, small and crisp, but distinct enough from its habit, divided pinnae, and spore cases, from *Asplenium-Adiantum nigrum*. We have found it since in great abundance all along the walls from the Logan Rock Inn to Gurnard's Head, but there is scarcely a hundred yards of wall (all the fields are walled), around Penzance, where *A. lanceolatum* does not grow. Devonshire lances have been much praised by tourists, but I do not admire them sufficiently not to wish they would let me see a little of the country they run through. Almost every yard of Cornish fence contains a painter's or a botanist's study. Lichen-stained stones of all rich hues, the lines between them filled with *Asplenium lanceolatum*, *A. Adiantum nigrum*, *Polypody*, *Lady Fern*, and *Bracken* at their base, and bunches of purple *Heath* on their summits, with a careless *Bramble* throwing a shadow across them; while bits of blue *Thrift*, and, perhaps, a *Foxglove*, give their sid in lighting-up the picture. Over the wall, perhaps, is the glorious sea, flecked with many a sail, stretching away to the dim purple line where it meets the sky.

There are various odours, mostly fishy, and notwithstanding the picturesqueness of sailors, and fishwives, and boats, and hanging nets, we walk on along the cliff. Here is a cottage perched on the rock, its *Enclisias* reach the roof, with stems the girth of one's thigh, and *Pear* trees laden with *Chaumontels*. What a feast in prospect! The road winds along the cliff; there is a strong scent of Almonds in the air, the *Tamarisk* flourishes, and a succulent that grows luxuriantly on St. Michael's Mount, hangs in masses from the wall on the right. It is a kind of

Mesembryanthemum, admirably adapted for rockwork. We peer over the cliff draped in wild flowers and Ferns, and just below us is a splendid tuft of *Osmunda regalia*. It grows plentifully all along, though not large; by the Gurnard's Head, however, in a watercourse, it is grand. There are fairy bowers of it over crystal pools of water that make us envious—one such to grace our fernery and we should be happy. But let us get down on the beach, it is hard climbing yet worth the trouble. Hundreds of plants of *Asplenium marinum* grow in the shady places under the cliff. It is an elegant Fern here, particularly when drooping, which seems its most natural habit of growth. The younger plants are best for potting; a light sandy and peaty soil suits it, and a little salt should be put in the water occasionally. For a greenhouse fernery it is most effective, but it will not grow out of doors unless within reach of the sea spray.

Past Newlyn is Mousehole, a fishing village, and reputed to be the hottest place in England. The cove, which is much visited, lies under the cliff beyond the village. It is difficult of access, but well worth seeing; the roof and sides are completely covered with *Asplenium marinum* and *Athyrium Filix-foemina*. The latter does not grow large, but has an elegant drooping habit, and contrasts well with the glossy dark green *Asplenium marinum*.

But here are Potatoes. This is where they come from long before they even make their appearance in the most sheltered spots round London. Potatoes and Cauliflowers are a specialty of the neighbourhood, and we certainly never tasted Potatoes so good and yet so handsome, and Penzance itself consumes an enormous quantity of them. Here is an old native at work in his plot. He is respectful but shy at first; then, as he becomes interested in our interest, he takes off his old straw hat, rubs his venerable pate, puts down the spade about 6 feet long, and tells us all about it. (By the way, the Cornish spade is surely a more scientific implement than ours, which requires so much stooping, and loses the valuable assistance of the knee as a fulcrum). His Potato garden is only about 30 yards by 10, and the crop, owing to the dry weather, is not large but excellent in quality. He points out that the manure, chiefly ashes, has not had the chance to decay; but the soil is good enough for potting, and two crops a-year are the rule, the second crop being Cauliflowers or Mangolds, which are transplanted of course to the Potato ground. Just along here for half a mile is the most favoured spot in Cornwall for early Potatoes and Cauliflowers. The plots are for the most part very small, many not 10 yards square, but sheltered by high hedgerows, chiefly Alder, or stone walls about 5 feet high. The sort almost exclusively grown for early market is Myatt's Prolific, which is much preferred to the Ashleaf, and sets are sprung early, planted in November, and frequently hoed before Christmas. The aspect, as my informant said, lay just in the eye of the sun, and was singularly exempt from frost. Last year Potatoes were dug in April, and brought 2s. 6d. per lb. in the London and Birmingham markets. The grower, we were told, sold £40 worth from a tithe of the land which he bought for £70. The late sort, or “keepers” as they are called, are Paterson's Victoria and Fikes. Paterson's, he assured me, were ousting the Flukes; they were “mar mealy and better crappers.”

We bid our old friend good day, and strolled on to the Logan Rock, an immense boulder of granite poised on the summit of grand sea cliffs. After gazing awhile on the tremendous precipices, and the beautiful and never-resting sea at their base, round which the sea birds floated and screamed, we turned our eyes landward and found some beautiful specimens of *Asplenium marinum*. A frond or two which we broke off 4 or 5 inches from the stool measured 2 feet 8 inches. There were probably finer specimens to be had for searching. From the coast for a few miles inland, the country is here singularly destitute of trees. The extreme violence of the south-west gales, I imagine, so strips and bruises the young leaves, that the trees do not recover from the attack.

I had forgotten to say that we passed in our journey the new telegraph station, and the beautiful cove of Lamorna. In the valley leading to the latter we found *Lactrea recurva*, with several other Ferns of less note. It is finer in Devonshire, however. In the neighbourhood of Clovelly there are miles of it, and certainly it is here the most elegant in form and colour of all the British Ferns. When grown in favourable situations it has a peculiar softness and bloom that I cannot describe, the result, perhaps, of the crisping of the edges of the pinnules. We found it all along under Cairn Galva, by the road side, and finest in the pits and sides of the old workings

of a tin mine. *Hymenophyllum tunbridgense*, which was said to grow at Cairn Galva, we could not find.

Our next halt was at Gurnard's Head, a bold rocky promontory stretching due north. *Asplenium lanceolatum* had accompanied us some miles, and once or twice we found it with fronds a foot long, but then only growing in deep interstices in the walls. When in a favourable position it is dark green, and most elegant in habit. To the left of the road down to the beach, having Gurnard's Head on the left, and below a raised platform for boats, we found an immense quantity of large *Asplenium marinum*, and the most elegant little cave it is possible to conceive.

A walk of six miles across from Morvah, brought us on the Wednesday evening to our lodgings at Penzance, and the change from north to south of the narrow peninsula was striking. The entire absence of trees and bareness and wildness of the country in the north are oppressive. The cottages have no gardens in front, and, indeed, few anywhere, but gradually as one proceeds south the trees appear dwarfed and lichen-stained at first, the Firs just tufted with a solemn green, their stems and branches almost white; then, gradually, as a friendly shelter is afforded by a hillside, Oaks and Beech begin to thrive; and as the warm valleys on the south open out to the sea, fine timber appears, and orchards loaded with fruit. Immense quantities of Black Currants, and small fruit are grown. Raspberries are 4d. a-pint; Gooseberries, 1d. "But what about *Adiantum capillus-Veneris*?" some of your readers will ask. Well, we found it one spot in great plenty though small. Thousands of young plants grew on the cliff round about. I must let your readers search. There are several places, however, where the graceful fronds nod in mockery from the cliff between St. Ives, and—there, I had almost said. When, however, your readers have searched so long and toilfully, they will be as loth to let the secret out as your obedient servant.—**PENCIL.**

THE MANUFACTURE OF TAR PAVEMENT.

Tar pavement may be made of the ordinary cinder-dirt produced in gasworks, of shingle, or of a mixture of both. The material is burnt in heaps like ballast, and when hot is mixed with hot tar. In practice a small fire of coke is made on the ground, and covered with cinder-dirt or shingle. When this layer is hot another is added, and so on in succession until a large-enough heap has been provided. The tar is now boiled in an iron copper, and taken when hot and mixed with the hot material from the heap already described, in quantities of two bushels at a time, in about the proportion of one gallon to every bushel of cinder-dirt, and slightly less than a gallon for the gravel. It is turned over and over with the shovel until every part of the material has got a covering of tar. Then the whole is passed through a sieve with $\frac{3}{4}$ -inch mesh, and part of it through another with $\frac{1}{2}$ -inch mesh, and put in heaps until required. Indeed, it may be kept for months before being laid down.

Before the pavement is laid, an edging should be provided about 2 inches thick, and projecting 2 inches above the surface of the ground to be covered, which should be tolerably even. It is advisable to have the ground next the curb well trodden on and rammed before the pavement is laid, otherwise there will be an unseemly hollow next the curb. In laying, the rough stuff is put down first and rolled tolerably firm, then the second quality is put on, then the third, and when the whole has been raked level, a little of the finest material is sifted on through a sieve with $\frac{3}{4}$ -inch meshes, and a little fine white shingle or Derbyshire spar is sprinkled on the top. The whole must now be well rolled. The best roller is a water ballast roller, which at first is used without ballast, and well wetted to prevent adhesion of the material, and when the pavement is slightly consolidated, the full weight should be applied.

For heavy cart traffic the material should be made of shingle only, heated and mixed as above, and well rolled. Both descriptions of pavement are laid best and most easily in warm weather, and should be rolled when the sun has warmed it well. Those parts in angles should be well rammed and rimmed off with a light shovel.

Though apparently a simple manufacture, there is a little difficulty in ascertaining the proportion of tar to gravel or cinder-dirt. A little experience will only be necessary in this, as well as in all other manufactures, to enable anyone to carry it out successfully.

This pavement cannot be spoken of too highly, as it is cheap,

wears well, and can be easily repaired. The colour, which never can be made to equal York flag, and the smell for some time after it is laid, are the only objections to its use; it can be laid with a good profit in any district at 1s. 4d. per square yard; and besides being a boon to the public, who must otherwise walk on gravel, is a great advantage to gas companies.—(Nature.)

PORTRAITS OF PLANTS, FLOWERS, AND FRUITS.

TILLANDSIA LINDENIANA (M. Linden's Tillandsia). *Nat. ord.*, Bromeliaceae. *Lim.*, Hexandria Monogynia.—This, the largest-flowered of the genus, is a native of Brazil. Flowers violet-blue with white-based petals.—(*Bot. Mag.*, t. 5856.)

CYMBIDIUM CANALICULATUM (Channelled-leaved Cymbidium). *Nat. ord.*, Orchidaceae. *Lim.*, Gynandria Monandria.—Native of N.E. tropical Australia. Flowers purplish brown, and green edged, lip white with pink spots.—(*Ibid.*, t. 5851.)

MALOPE MALACOIDES (Barbary Bastard Mallow). *Nat. ord.*, Malvaceae. *Lim.*, Monadelphia Polyandria.—Native of southern Europe and north-western Africa. Flowers rose-coloured with crimson lines.—(*Ibid.*, t. 5852.)

ERITRICHUM NANUM (Dwarf Alpine Eritrichium). *Nat. ord.*, Boraginaceae. *Lim.*, Pentandria Monogynia.—Native of the entire range of the Alps. Flowers bright blue.—(*Ibid.*, t. 5853.)

ASIMINA TRILOBA (North-American Papaw or Custard Apple). *Nat. ord.*, Anonaceae. *Lim.*, Polyandria Polygynia.—Native of the middle, western, and southern states of North America. Fruit fragrant and eatable. Flowers brown, deeply reticulated.—(*Ibid.*, t. 5854.)

CYMBIDIUM CANDIDUM (Small white Lady's Slipper, or Mocasson Flower). *Nat. ord.*, Orchidaceae. *Lim.*, Gynandria Diandria.—Native of bogs of New York States, Kentucky, and Wisconsin, and further northward and westward. Flowers white with purple bands, lip dotted with the same colour.—(*Ibid.*, t. 5855.)

TULIP—*John Henry*.—It is white edged with dark purple. "Mr. John Hepworth, of Huddersfield, says—'The Tulip John Henry was raised from seed sown in 1856, the pod having been gathered two years previously from the No. 1 fine strain of that very old favourite Louis XVI., impregnated with a very fine seedling by bloemen breeder. From the same pod of seed I have obtained several other superb seedlings, not yet named.' Mr. Hepworth further states that no bulbs of this variety have as yet been parted with, nor will there be any for distribution before August, 1871, but should the stock at that time amount to one dozen good blooming bulbs of the rectified flower, it will then be in the market at the price of one guinea each bulb. The breeder, which in the breeder state is also a first-class show flower, will also be sent out at 7s. 6d. each. In case any untoward circumstances should intervene to prevent this number from being obtained by the time stated, the bulbs must be kept back till August, 1872."—(*Florist and Pomologist*, 3 s., iii., 169.)

LAWN MOWERS.

I WAS sorry to read the remarks at page 121 respecting lawn mowers. We have had for nine or ten years one of Messrs. Green's 24-inch machines, and I can safely say I cannot wish for a better machine for lightness and good work. It is worked by two men, who have three acres to keep in order. This machine we send to London once in three years to undergo repairs.

I am sorry to say we have one of the Archimedean lawn mowers. I have cast it aside after three months' trial, and I cannot make anything of it. The first time I tried it unfortunately it came in contact with a small stone, which made a great gap in the revolving cutter. Stones are not in their proper place on lawns, we know, but the keenest eye does not always see them until too late. I hope all those who have tried this new machine will give us their opinion, that we may know if the fault is behind the handles or not; if it is, we will try it again. I should almost imagine that the 16 inch machine which Mr. Daines has is out of order, if it cause hard work for two men.—**EDWARD COVENEY.**

[We think the correspondence relative to the comparative merits of lawn mowers had better cease. We have no doubt, in fact we know, that all those now manufactured do their work well. Which does it best—that is, which ribs least, re-

quires least labour, and is least liable to be out of order, can only be determined by comparative trials by a jury of competent, disinterested tryers.—Eds.]

ARRANGING FLOWERS.

It is astonishing how very few people know just how to display cut flowers to the best advantage. Everybody must have bright blossoms in the parlour vases now-a-days, but the combinations made are enough to vex the soul of a person with the least artistic taste. What business has a blue Larkspur—beautiful though it may be in itself—by the side of a Scarlet Geranium? or by what law are Marigolds and Roses brought together?

In the first place one must have the right kind of a vase, and I will give my ideas of the fitness of things. Vases should not be very high, unless they are wide-topped, in which latter case branches of foliage and tall spikes of bloom should fill them; for instance, either a ground glass or a ruby vase a foot high is well furnished by common Lily leaves, or leaves of Mountain Ash, with white Petunias, or any long-stemmed white flowers. Parian vases of the many pretty patterns are beautiful always; so are those of engraved glass. I have a little one of the Fern pattern about 6 inches high, which occupies a carved bracket over the sewing machine. This year it began very early to hold forest flowers—spring beauties—and Hepaticas; Violeta white and blue; then a handful of Adder's Tongues (*Orehis spectabilis*). Then came the garden flowers, of which I notice some pretty arrangements, Ribbon Grass, Pear blossoms and Tea Violets, Lily of the Valley, with its leaves and a single purple Pansy; a bit of white Lilac and Dielytra; Roses during their season; and now, since the fragrant Lilies of June are gone, I take very kindly to bright Geraniums and Verbenas, feathery sprays of Gypsophila, a little Mignonette, and leaves of the Rose Geranium, which I always grow in great abundance for bouquets, not forgetting a stem of the variegated Balm, which always harmonises with scarlet or crimson flowers. A couple of Fern fronds (*Aspidium acrostichoides*) and the delicate Hare-bell are pretty together, or Hare-bell and white Spirea; St. Peter's Wreath, bent so as to simulate a basket handle, and flowers of any hue filling the basket. A great Datura may be put in a narrow-mouthed vase, and this natural vase, with water in it, may hold a cluster of delicate blossoms.

Some flowers show best in plates; saucers of Pansies edged with Musk are lovely; so are Balsams with plenty of their own leaves. Fill a pickle-shell with Caraway leaves, put a white Jonquil in the centre, from which let five sprays of Lily of the Valley radiate; or a star may be made of Daisies and Myrtle; or of blue and white Larkspur. Verbenas as well as Phloxes are prettiest when looked down upon. Many of the Grasses mingle well with flowers, and they are so graceful that a whole bouquet of them is not to be despised. Ferns, too, all by themselves, are very pretty. I saw them in a church lately, so bravely green, so delicate and airy, that I doubt not other eyes than mine found them a rest after looking at the round bunches of strong-hued flowers standing near. Sedges and Ferns are especially pretty before a window, where one can get the full effect of their delicate outlines. Nothing is prettier than a small basket of Ferns in a window with plenty of bright Cardinal Flowers.

Late in the autumn one is often so luckless as to have many unripe Melons. Cut off the bottom of one so that it may stand firmly in a soup plate, surround it with stiff foliage, Pæonia for instance; then stick the Melon full of Dahlias or Asters. This makes a symmetrical bouquet, and is the most satisfactory way of treating Dahlias, which I have found exceedingly difficult to manage otherwise.

I have only hinted of my subject after all. One needs to study flowers, their manner of growth, their affinities, their prominent traits, and then one would not bunch them together stiffly and destroy their individualities. Give them a place upon the dining table every day; let them stand before you when you work or read; wear them in your hair when you go about your work; and some of their grace and fragrance will surely sweeten your daily life.—(*Rural New-Yorker*.)

NEW FLOWER MARKET IN LEICESTER SQUARE.—There is a talk, which we earnestly trust may ripen into action, of making Leicester Square a flower market. A more desirable change could not take place, desirable not only in an architectural and æsthetic sense, but on moral and sanitary grounds. Perhaps

within a year or two we may see that desolate gamin-haunted area covered with pretty buildings and a bright array of flowers, whose perfume will replace the unsavoury odour which now prevails the square, and whose presence will assuredly induce a purer and more respectable moral atmosphere. Covent Garden, too, which has long suffered from reptation under a badly arranged system, would find no little benefit from such an establishment as is now proposed.—(*Food Journal*.)

FRAGMENTS.

WELL, I am away from Redcar, and what may be called Captain Cook's district, for I learned that the father of that circumnavigator was buried at Marske; the Captain was born at Marton; he was apprenticed at Staithes; his brothers and sisters are buried at Stokesley, where also his mother rests, and whose shoe is preserved in the Kirkleatham Museum—all villages around Redcar. I am away from the district, have wandered since to the north and south of it, but having rested nowhere remember only some fragments, disjointed and superficial, that may be deemed worthy of filling a gap in your columns; first among which is of and about Durham, that city associated from childhood with Mustard. Mills for its grinding I saw there; but why it should there be a speciality is probably not known to many of your readers—no fields devoted to growing Mustard seed are to be seen; but it is said that Charlock seed was the original seed used for Durham Mustard, and I saw too much of that weed in some of the Durham fields.

Prior to 1720 no such luxury as Mustard, in its present form, was at our tables; the seed was only coarsely pounded, as coarsely separated from the integument, and in that rough state prepared for use. In 1720 it occurred to an old woman of the name of Clements, resident at Durham, to grind the seed in a mill, and to sift the meal as in making flour from Wheat. The secret she kept for many years to herself, and supplied the principal parts of the kingdom, and in particular the metropolis, with this article; George I. stamping it with fashion by his approval. Mrs. Clements twice a-year travelled to London, and to the principal towns throughout England, for orders, and the old lady contrived to pick up, not only a decent pittance, but what was then thought a tolerable competency. From this woman living at Durham, it acquired the name of Durham Mustard.

Of all the genera of residences scattered over England, none ever have been so inviting to me as those old-fashioned family residences, setting all architectural rules at defiance, that have been compounded from time to time by successive generations without regard to any consideration but the present requirements and comfort of the occupants, until, at last, no observer can detect which is the centre, for it seems all wings. Just such a residence is Ayley-heads, near the Mustard capital. A residence is known to have been on the present site for five hundred years—Alan de Billingham in 1371 was possessed of land at "Akelyheads" in right of his wife Agnes—and though that, and probably many successors have been levelled, yet the existing house bears evidence by its long passages, many divisions, panelled rooms, and decorated ceilings, that it has had many generations within.

Ac, is the Anglo-Saxon for an Oak; *legh* or *ley*, for a stead or place; and *heafd*, for a head, and I accept such a derivation, for the house commands an extensive view from the highest of a series of elevations, and in a place of fine Oak and Beech trees. It is not a show place, but the grounds are well arranged, well kept up, and where one can glean useful facts and suggestions. The owner (one of your editors will say "of course"), is a Johnson, and asks questions of Nature. He has been a planter and replanter of evergreens for some thirty and more years, and he showed me Hollies, from 6 to 12 feet high, that had been transplanted one, two, and three years, all doing well, and all removed in June, just when the buds for the year's growth are beginning to burst. He says they never fail them, care being taken to have a good ball of earth about the roots, and, when placed in the hole prepared for them, covering them with earth, then soaking it with water, and finally filling in the remainder of the earth. I saw there also a direct proof of the good influence of mulching the roots of old fruit trees. The soil is light, and some Apricot trees about thirty years old had latterly shed their fruit unripe during dry summers. The surface over their roots had been mulched this year and well watered. The soil beneath the

maturing never dried, and the Apricots, a good crop, were ripening, and none had fallen.

There is a terrace before the house, and flanking a portion of that terrace is a Yew hedge about 6 feet high. This forms a good background to a ribbon-border, the rows in which are Hollyhocks, Dablias, dwarf Roses, Perilla nankinensis, Scarlet Geraniums, yellow Calceolaria, Lobelia speciosa, and white-edged Saxifrage, but this last is too tufty, and Arctotis reptans, old Donald Beaton's "frosted-silver plant," would be more effective.

In the vicinity I had great pleasure in conversing with the author of one of my favourite works, "The Land of Israel," the Rev. Mr. Tristram. He gave me much information relative to the Holy Land, and I would gladly have asked him about its Pigeons and poultry, just to gratify his brother cleric, "WILTSHIRE RECTOR," but I remembered the story of the farmer to whom a reverend Palestine traveller was relating the discoveries in and about Jerusalem, stopping the interesting narrative with the inquiry, "Beg pardon, Sir, but how be's the Turmetts out there?"

"Up and away from Palestine," and my next remembrance is of Barnard Castle, from whence I rambled among the herds of red deer at Raby Castle; hung admiringly over the ruins of Atherstone Abbey, and the views of the Tees from the battlements of its bridge; lingered at Wycliffe, the place of origin of our great Reformer—great in the eyes of all Christians, for he struggled for what he considered the truth; but I rested at night at the King's Head, going ever and anon to walk in the gardens around, and on the ramparts of the ruins of Barnard Castle, which are visitable from the yard of that most comfortable hostelry.

There are some flag stones near the entrance of the keep of the Castle, and having ascertained that they covered the entrance to the dungeons, I inquired if they were visitable, and was told in the negative, and that Mr. Charles Dickens had

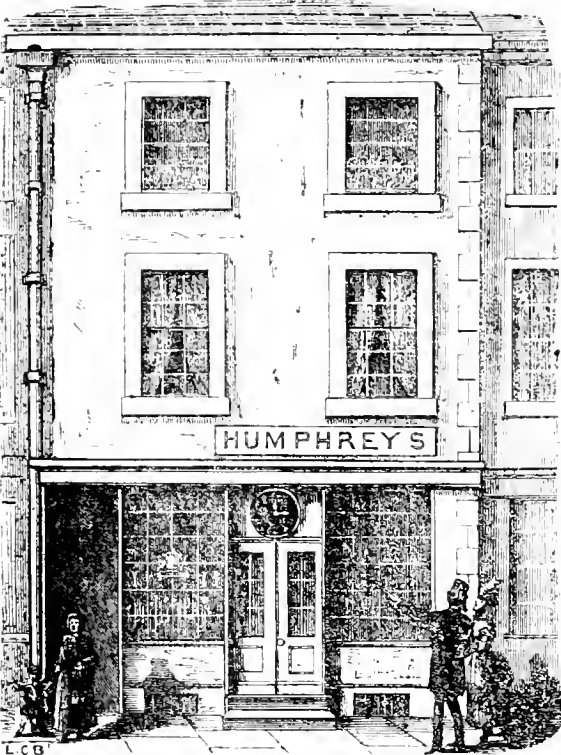

similarly inquired. This led to further talk about our great novelist, and I found that the garden and ruins had been his frequent resort whilst making inquiries about the "Do-the-boys-hall" schools; and that my sitting-room, like his, directly faced the house on the street's opposite side, which led to the adoption of the well-known title, "Master Humphrey's Clock." Of that house I append a sketch, and regret that I could not converse with its owner, and Mr. Dickens's correspondent, in-

asmuch as that he died some twelve months since. The watch-making business is still continued by his widow, and there is an old-fashioned appearance about the shop's contents, in the window being suspended, among other old-world things, a preponderating number of those little fat watches, looking as if poached in silver.

Last of my reminiscences must be of Whitty and its associations, prominent among which is its jet. Few wearers of the ornaments of which it is the material are aware that it is only a variety of coal, and, like it, is only wood reduced to charcoal under a high pressure in some former volcanic conflagration. Jet in some way owes its peculiar characteristics to its being the coal formed from coniferous trees. I have a piece of rough jet in which the annual-formed rings of the Conifer are plainly marked.

Next among my Whitty memories are the ruins of its Priory, and its history adds to the testimony, that though the failings and excesses of the monks were many, yet they were national benefactors; they promoted literature and the culture of the soil. Even their excess in luxurious living induced attention to the rearing of superior animals for the supply of the refectory. Some notes relative to Whitty Priory, notes gathered from Domesday Book and the Priory's Register, afford confirmatory evidence. They show that the Priory lands alone were cultivated in the manor of Whitty, all the rest were waste. The Priory poulterer was an officer of sufficient position to have a horse allowed him. No gardener is mentioned, but, as at the Abbey of Evesham, it was probably managed by the Priory almoner. That gardens were cultivated in the vicinity is testified by their tithes rendering to the Priory 6s. 8d. annually.

A ramble to the woods of Mulgrave Castle closed my summer's holiday. The roads through those woods are truly delightful and very varied; they extend for many miles, and were chiefly formed by Maharajah Dhulep Singh whilst tenant of the estate, but it is now again inhabited by members of the family of its owner, the Marquis of Normandy.—G.

GARDENING IN THE LONDON PARKS—No. 2. HYDE PARK.

NEATNESS is one of the leading principles in the management of dressed grounds. Gay, well-filled flower beds, handsome shrubs, and so forth, are things to care for, and to each a proper share of attention must be devoted; but without the greatest possible care in the maintenance of order and cleanliness, both among the plants and their surroundings, little enjoyment is likely to be derived from them, however beautiful they may be. The importance of this principle appears to be fully recognised by the superintendent of the flower beds in Hyde Park, for one cannot fail to notice the exquisite neatness which prevails both in the flower beds there and in their surroundings, all of which were in the best possible condition in this respect at the time of my visit, August 5th.

The outlines of the whole of the beds in Hyde Park are simple in the extreme, and rightly so too, for the flower garden, if I may so call it, consists of a series of long, narrow strips of turf, on which are the beds, extending from the Marble Arch to Stanhope Gate by the side of Park Lane. A detailed description of the whole of these beds would offer but little to interest your readers, I shall therefore confine my notes to a description of a few of the more striking beds, or those which, by the excellent arrangement of their occupants, are worthy of imitation.

Some good circular beds had an outer row of *Sempervivum californicum*, inside which was a row of Golden Feather *Pyrethrum*, with a compact central mass of *Coleus aureo-marginata*. These beds had a neat effect, but others, having crimson *Amaranthus* instead of the *Coleus*, were much brighter. The turf on which are the principal beds narrows to a point at the end close by the Grosvenor Gate. At its extremity was a charming little heart-shaped bed, the soil of which, as in most of the other beds, rises so abruptly as to form a miniature ramp; on the face of this is a row of the neat *Echeveria secunda glauca*, a row of Golden *Pyrethrum* coming next, with a centre of *Coleus Verschaffelti*. The surface of this bed was not decidedly flat, but by the skillful pinching of the *Coleus* it was made to rise very gently to the centre. Nothing could surpass the exquisite neatness of the bed, which was as near perfection as possible. From it a series of parallelogram beds is continued for a long distance. The formality of these long lines is broken

about halfway along them by a group consisting of a large oval bed of *Rhododendrons*, on each side of which, in a line with the other beds, were two small hearts, with a circle of proportionate size between them, making six beds besides the large oval. In the small circles was a central mass of *Alternanthera magnifica*, surrounded by a row of Golden Feather *Pyrethrum*, with a broad border of the very dwarf grey *Antennaria tomentosa*. Each of the heart-shaped beds had a central mass of *Coleus Verschaffelti*, surrounded by Golden *Pyrethrum*, with an outer row of *Echeveria secunda glauca*. The high finish of these beds left nothing to wish for, and the arrangement of the plants was most satisfactory. *Alternanthera magnifica* has handsome orange and crimson foliage.

Of the long narrow beds, I may mention as being very good one filled with *Pelargonium Christine*, having an edging of alternate plants of *Lobelia speciosa* and *Pelargonium Lady Plymouth*; another with the same kind of edging, and *Pelargonium Waltham Seedling* in the centre; and another of *Pelargonium Amy Hogg*. There were several side beds of *Calceolarias*, but all had a very poor appearance. A quantity of the dull ragged grey-leaved *Artemisia Stelleriana* was very tame indeed. A number of long narrow beds had edgings of alternate plants of *Lobelia speciosa* and *Dactylis glomerata variegata*; inside this was a row of Purple King *Verbena*, with various kinds of variegated *Pelargonium* in the centre. This was rather an unsafe arrangement, but as the *Dactylis* predominated very much, the blue and purple did not clash sufficiently to materially affect the appearance of the beds. In some mixed beds of *Viola cornuta* and variegated *Pelargoniums* the *Viola* was a decided failure, its weak straggling growth being almost without flowers.

Of eleven beds which I noted as containing each a variety of variegated *Pelargonium*, one containing Queen of Queens mixed with *Verbena Purple King* was very good; *Artemus Ward* was very dull. Golden *Fleece*, free in its growth and with bright-coloured foliage, was good, but it is not by any means equal to *Crystal Palace Gem*, of which there was a fine mass. Some of these beds would have had a much better effect had the blossom been kept picked off the plants. Some rows of *Verbenas* introduced in several mixed beds were very poor indeed, with very few flowers. The beds of various Zonal *Pelargoniums* were well filled, but the flower trusses had been so battered by recent showers that I was quite unable to form a fair opinion of their merits. The uniform appearance of the fringe of *Sempervivum* or *Echeveria*, which surrounds most of the beds here, imparts a finish and contributes very materially to the air of neatness which pervades the whole of them.

On the side of Rotten Row, near Hyde Park Corner, were a few noteworthy fine-foliated and tropical plants. Of these two very fine groups of *Canna discolor* bordered with *Tussilago Farfara* variegata, the variegated *Coltsfoot*, had a most striking effect. Good specimens of *Monstera deliciosa*, *Musa Ensete*, the graceful *Phoenix dactylifera*, a fine *Scaevola robusta*, *Phoenix reclinata*, *Lantana borbonica*, and the singular and striking *Phormium tenax variegatum*, all presented a healthy and flourishing appearance.—EDWARD LUCKHURST, *Egerton House Gardens, Kent*.

WORK FOR THE WEEK.

KITCHEN GARDEN.

GROUND now becoming vacant should be trenched up as roughly as possible, manure being applied if necessary. This should always be done as soon as the crops are off, whether the ground is wanted immediately or not. Trench and manure well for the winter *Cabbage* in due time, and plant out some more strong plants of the early kinds for late *Coleworts*. Young seedling *Cauliflowers* must not be allowed to stand too thickly in the seed bed; the thinnings may be pricked out at sufficient distances, and will make sturdy plants. If any strong *Celery* plants remain, they may be taken up with balls and "heeled" deeply for soup purposes; this will save the stock for salads. Plant out more *Endive* for the last batch, using high slopes, which may be protected by covers or hoops and mats in severe weather. Sow Hardy Green *Lettuce* on sloping banks to stand through the winter. These banks may be rather small, not more than 4 feet through at the base, and steep; sow on both sides of the bank, and it will produce a succession. See that *Spinach* is properly thinned and the surface stirred. Make a good sowing of approved sorts of *Radishes* for winter use. Let all the *Scarlet Runner* pods be picked clean, except a few for seed; if allowed to grow old they exhaust the crop much, and

prevent succession. Thin *Turnips* in due time, and pass the hoe among them.

FRUIT GARDEN.

Fig trees out of doors should be liberally supplied with water if no rain ensues, to enable them to swell off the late fruit. Give a final nailing to all wall fruit trees, that there may be nothing to obstruct the perfect ripening of the wood. Fruit of every sort should be gathered as it ripens, and not be allowed to fall. Grapes out of doors should have every shoot of useless wood removed, and the branches laid in close to the wall. Wherever it is practicable, it is of great advantage to them to place the spare lights from early Peach houses or vinerias against the wall; when this is done, a good crop of fairly ripened fruit may often be obtained.

FLOWER GARDEN.

It will be well to fill up many blanks in flower borders as soon as possible with plants of a biennial character, such as Wallflowers, Sweet Williams, Campanulas (the *Campanula grandis* is a useful sort), Hollyhocks, biennial Stocks, and the various Primulas. Most of these, although somewhat old-fashioned, will be found very useful next spring. All spare time will now be probably employed in the reserve garden, as success during the spring and summer months depends in a great degree upon the efficient manner in which the labour is performed just now. Still continue to propagate showy and choice herbaceous plants by cuttings and division of the roots, and seedlings of late-sown perennials may still be pricked out with advantage. Pot off a good number of the different varieties of Brompton, Giant, and Queen Stocks; likewise Pentstemons, Antirrhinums, Linums, Viscarias, &c., that they may have a little protection should the winter be severe. Continue to plant out Pinks, Clove Carnations, and rooted cuttings of hardy herbaceous plants in nursery beds. See that the plants already established in beds are kept in a state of health and vigour by stirring the surface of the soil. Look now and then at the late-budded Roses, and loosen the ligatures; when necessary, pinch back to half their length those buds which have made shoots. If left at full length they are apt to be blown out by the winds. Remove all shoots and suckers from the stock; if left too long in their present position they have a tendency to weaken the constitution of the stock. Roses budded last year will likewise require attention. See that the heads are well secured against high winds, which generally prevail during this month and next. The early Carnation layers are now well rooted. In potting them off, either one or two plants may be placed in each pot, according to the convenience which the amateur may have for wintering them. Care must be taken not to have the soil too light, and manure or any stimulating composts must be avoided; in fact, the soil cannot well be too simple or pure; decayed turf with a little sand is found to be the most suitable for their winter's growth. Procure varieties from the different cultivators, so that they may be well established before winter. The offsets of all choice sorts of Tulips may be put into the ground as soon as convenient, choosing fine dry weather for the operation. It will be found a good plan not to let the beds have too much moisture, hooping them over, so that mats or other protecting material may be thrown over in excessive wet. Where Pinks have been planted out in beds, they must be kept free from weeds, and old stools or stock plants which have been grown in pots may be planted out on borders. They will produce an immense number of flowers next season from which much seed may be saved. Make up beds of rich compost in rather a cool situation, and plant out rooted cuttings or young plants of Pansies for next year's blooming. Continue to shelter Dahlias, and to thin the buds as before directed.

GREENHOUSE AND CONSERVATORY.

Clerodendrons, early Camellias, well-grown Fuchsias, trellis climbers, Brugmansias, Scarlet Geraniums, &c., should now be in high perfection. The *Veronica speciosa*, and *Buddlea Lindleyana*, where properly grown, will also prove very interesting, as tending to sustain the true conservatory character. The two latter shrubs want very similar root treatment. Nothing of a stimulating character will bloom them in perfection. A plain simple loam, of a rather sound character, will be found to suit them best, accompanied by the one-shift system of potting. Luculias, and other winter-flowering plants growing in the border, must be freely exposed to light and air in order to have the growth well ripened, and to insure a fine display of bloom. Also, see that all plants are clear of black thrips, for this pest is particularly active at the present season, wherever

it is allowed to gain a hold, especially on *Luculias* and plants in a growing state.

STOVE.

Where there is but one house for the accommodation of tropical plants considerable care and attention are necessary to properly manage these at this season, as some having completed their season's growth require to be kept cool and rather dry, in order to ripen the wood, while others in free growth require to be encouraged with warmth and moisture. If there is no convenience for removing to a cooler house such plants as have made their growth, these should be placed together at one end of the stove, keeping them sparingly supplied with water at the roots, and giving air rather freely, which will generally serve to prevent any attempt at second growth; and those requiring to be kept warm and moist should also be placed together at the opposite end of the house, where very little air should be given, using every care to keep the atmosphere moist about them. *Allamandas*, *Clerodendrons*, &c., which have done blooming, may be removed to ainery where the Grapes are ripe or ripening, for as these will require very little water, they will not do much mischief in the way of causing damp, and their room in the stove will be found very useful for other plants. See that everything is free from insects, and keep the foliage of *Ixoras* clean by washing with a sponge and soapy water when necessary.—W. KEANE.

DOINGS OF THE LAST WEEK.

KITCHEN GARDEN.

In our greatest extremity, when we could obtain no water of any sort except what we carted from three to four miles, we had on the evening of the 22nd the most genial refreshing rain of the present year, and it came so softly that, whilst refreshing the parched soil, it did nothing to injure the masses of *Geranium* and *Calceolaria* bloom. On this, the 27th, there are yellow-tinted fleecy clouds in the west, which, with a falling barometer, give us hopes that we shall have more rain, and if so, then we may shortly expect a green carpeted lawn to set off the masses of bloom and to give additional crispness and succulence to all our vegetables. On the whole, in the kitchen garden, notwithstanding the heat and the extreme dryness, we shall not suffer so much as we expected, except in the case of Peas. We fear that they are gone beyond recall, though after the rain some of the rows seemed as if they would break afresh, and we shall leave them a little longer to see what they will do. The want of Peas in September is a great want indeed, but in this respect we believe we are no worse off than the generality of our neighbours, even in cases where water could have been had in abundance. The Peas, even in our case, suffered more from the dry, hot atmosphere, than from excessive dryness at the roots. A good syringing or engining over the tops, could it have been given, would have been more beneficial in many cases than watering with cold water at the roots.

Dwarf Kidney Beans and Scarlet Runners.—The loss of the Peas made us more anxious about the Kidney Beans, and in the case of both, and especially the Dwarf Kidney Beans, we had the rows gone over and every Bean arriving at the seeding state cut carefully off, that the strength of the plants should be thrown into the free production of young succulent Beans. In small gardens, where the greatest table supply from the smallest space is most desirable, it is scarcely worth while to save the seed, and if attempted, it is best to set aside a little piece for bearing seed, so as to have it well ripened. Amateurs should keep in mind, that a couple of Kidney Bean pods left on a plant to perfect their seeds will exhaust the plants more than a score of pods gathered when young and juicy. Such pods can scarcely be too young, if grown a little beyond the half of their full size. They should never be so old as not to break across freely, if they are expected to cook well. The incipient seeds should never be more than visible. The almost universal custom is to cut and shred even young pods before boiling, allowing much of their nourishing properties to escape into the water. We wish some of our readers would try boiling young Beans from 3 inches long, doing nothing to them except nipping the stalks and points off, and then report their opinion of the richer flavour of the dish.

Broad Beans, though excellent when young, and a fine standing dish when full grown and associated with bacon, are not appreciated, because not tried, as they ought to be, when the pods are young—just when the seeds are forming inside—the pods boiled whole, as indicated above for young Kidney Beans, and cut at table into the sizes most suitable for convenience.

In this case, as well as the young Kidney Beans, the peculiar richness is greatly owing to the inside of the Beans coming but little in direct contact with water. We shall be glad if a hint in this direction prove useful or suggestive. We have no doubt that very often the simplest mode of doing anything will turn out to be the best.

Vegetable Marrows.—Not long ago we saw a housewife pare off the outsides or skin of young Vegetable Marrows, preparatory to boiling them. She also cut them open. We did not wonder that the lady called them poor, watery stuff at the best. In our opinion they are one of the richest delicacies grown—so rich that we rarely taste them above once a year, but we should have had no desire to taste those thus peeled previously, so as to let the water thoroughly soak them. There are many ways of using this well-named Marrow, by boiling, frying, &c., but few modes for simple people are better than the following:—Select the Marrows when young, say from 6 to 8 inches long, and from 2½ to 3½ inches in diameter, cut them with a good long stalk, and if clean they need nothing more; if there should be a little soil, &c., rub or wash it off without grazing the skin; place them in boiling water with a little carbonate of soda in it; try with the point of a fork once or twice to see that they are done enough, but not so deeply as to let the water inside. When done slice them down the middle, and remove the soft inside, and then a little pepper and salt added, with or without melted butter, will yield a dish a king might envy. We never tasted a Vegetable Marrow where the water was permitted to get inside freely but we considered it spoiled. Good cooks, of course, can make them nice, however done, just as they could make delicious soup from flints with the good things they could add to the flints; but as Vegetable Marrows are rather plentiful this season, it may not be out of place to tell how they may be made most delicious. Even when they are grown to a large size, as in some cottage gardens, along with Gourds, for pies and puddings, the cottager might have many a dish from thinnings of the young fruit, as a plant will seldom bring many of a large size to maturity. To obtain this large size we have been mortified to see dozens of young fruit thinned out and thrown away, when even a little pepper and salt and boiling water would have turned them into a delicious dish; they are so rich that it is not every one who can partake of them very often, unless cooked in the simplest manner.

Winter Vegetables.—Thanks to a little sewage just at the roots, and frequent surface-stirring and forking, the earliest are more forward than we expected them to be, and after the refreshing rains of Monday, we turned out a quantity of Broccoli, Coleworts, Borcoles, &c., drawing deepish drills, and giving a little water along the drills after planting. Some of the plants, from standing rather long and thickly in the seed beds, had become somewhat leggy, and these we planted chiefly with the help of a crowbar, so as to get the roots deep enough. This was especially the case when we filled up the spaces between rows of Gooseberries and Currants, and where we should not have liked to have dug the ground too deeply, even in the middle of the space. It is always well to have plenty of plants in winter, even if one should pull them up early in spring. It was useless to plant earlier in the weather we lately had, and we did not think there was any occasion to hurry, as the first plantings-out were doing well.

Cauliflowers, after the rain, are becoming what they ought to be, and we hope they will form compact heads now, instead of spreading and shooting, as they did in the hot weather. In a piece planted in an earth pit, the greater part of which is now removed, and the space filled with Savoys, &c., even though assisted with sewage water, hardly a third came with compact heads; the rest shot away like a bad kind of sprouting Broccoli, good enough for hall purposes, but quite unfit to send to the dining-room. We planted out our last piece, to which we shall most likely give a little protection.

Most of our earth and turf pits, which we use for hardening off our bedding plants, are now filled with Lettuces, Little Pixie Cabbage, Rose Coleworts, and the Ulm Savoy beginning to heart well, and looking vigorous now, though standing merely one foot apart. All these we shall get off early in winter, as we should not be able to keep four-footed depredators from them, but they will give a great relief to the vegetables grown inside the walls. We have planted part of what we intend for our earliest spring main crops of Cabbage, giving such compact kinds as Veitch's Matchless 18 by 9 inches, and a larger kind, alluded to previously, 24 by 15 inches. We could hardly say which is the more profitable where there is a large consumption. A head of the latter is a regular fill-basket when well

grown. Two or three of the former, just when hearting and becoming a little white in the centre, look very well on a gentleman's table.

Our main last spring quarters of Cabbages were very stunted and blue in the hot, dry weather, and we used younger plantings, chiefly because they were sweet, soft, and succulent; but now after the rain these old quarters are much improved, and in an ordinary winter we shall be able to cut plenty from them. In going through the rows we noticed that the bulk of the stumps were producing from five to twelve young Cabbages, and as they are removed more will come. We like young Coleworts very well; they are nice from October and onwards to the spring, but even planted from 10 to 12 inches apart the yield is small in comparison with that obtained from an old Cabbage bed. Lately we have heard and listened to advice to destroy the old Cabbage quarter and depend on younger plants, but we would like all who consider the question of profit and loss to think twice before clearing away such a source of a large continuous supply in winter. We generally allow ours to stand all through the winter until we want the ground for Peas and Celery trenches.

Celery.—We were obliged to shade the beds we planted in order to keep it alive, and even with some showers we shall be later than usual. The chief bulk is still unplanted, because we could shade and even water where it was growing thickly in beds, which we could not easily do when transferred permanently to the trench beds. Fortunately the plants were pricked out rather thinly, are now strong and luxuriant, and as they will lift with large balls they will suffer but little from the removal. We must, therefore, vary our practice according to circumstances. With so little water, if these plants had been transferred to the trenches we should have expected the most of them to have started into bloom from mere dryness. We shall be both surprised and disappointed if one per cent. of these plants, after being turned out, should bolt; and as we expect to have more moisture in the autumn the plants will grow very fast and vigorously. September is the great month for Celery growing. We have earthed-up none as yet, though in general we used to be taking up long before now. At one time it was judged necessary to have large fine Celery at least by the middle of July, but it could not be had large and fine so early without a good degree of forcing and no lack of moisture.

Mushrooms.—Owing to necessary repairs in the Mushroom house we shall not be able to commence there for some time; and not wishing to have a break in the supply, if we can obtain water enough to wet, heat, and partially decompose a lot of dryish litter, we think of making a bed or two out of doors in the old-fashioned ridge or triangle form. At the present time we would not make these ridges large, as then they would be apt to retain the heat too long to enable us to spawn them quickly. For a bed to stand through the winter they ought to be larger, say at least 4 feet wide at the base, and 3½ feet to the apex. With good covering to keep out cold and wet, we have never had better Mushrooms than from such out-door ridges. Of course there was trouble in uncovering and covering. For a temporary purpose, such as we propose, we should be satisfied just now with ridges 30 inches wide and 24 inches in height, made of rather more than half-decomposed dung, and then a couple of inches or so of droppings added all over. We are rather inclined to this because we cannot make up our mind to follow the usual rotation in the open shed, which we use for summer cropping. The first summer piece has there been bearing freely for about six weeks; the second little piece is showing here and there like pin heads, quite as soon as we wanted. What would have been the third piece is occupied by a bed made just a twelvemonth ago, and which produced freely in October, November, and the first part of December, and then was pretty well neglected, as the house beds gave us plenty to go on with. This little bed, as witnessed by some of our leading gardeners the other day, is a proof that many of the failures with Mushrooms are the results of mistaken kindness. This bed was neglected during the winter, and in a cold night, though a little was left, the chief part of the covering over it was removed to protect other things. In the spring the other beds in the shed were turned out for compost-making, top-dressing, &c. In coming to this little bed the man who attends to the Mushrooms drew our attention to the freshness of the spawn. He cleaned the surface well, made a few little holes, and gave the bed a good watering with warm manure water at about 100°, covered it up with a little hay and litter, as far as we recollect, about the end of April, and from the end of May and the middle of June we have gathered freely, and

there are good Mushrooms now at the end of August. Of course it has not equalled in yield the first bed put up in the shed this season, but it still yields enough to render it a little imprudent to turn it out for the sake of immediately making a new bed. As far as we recollect the flat bed is about 16 inches deep, and the bulk of it is short dryish litter, with a casing of about 3 inches of droppings. No doubt the rest in winter helped it to produce this summer. All we can say is the Mushrooms were very acceptable, as they came in well when those in the house were becoming rather thin in texture before the first bed in the shed was ready.

We have frequently alluded to the simplest modes of obtaining Mushrooms. Perhaps the chief cause of failure is a want of patience. The material must not be spawned too hot. It is easy to give a little heat, when necessary, by covering, watching that the covering does not make the bed too hot. Of all materials we prefer horse droppings, with nearly an equal amount of short litter—not too much wasted, decomposed, or dried previous to use.

For ridge beds, nothing is better than dryish half-decomposed littery dung, such as is often obtained from the linings to hot-beds. One of the best beds we ever had in a shed was made of equal parts of stubble, longish dryish litter, and rather long green grass. We relied on the grass to give a certain amount of moisture to the other materials, and also a fair amount of nitrogen. These materials did not heat very strongly, but, as they were well mixed, enough to consolidate them when trodden and beaten. When the heat was on the decline, 2 inches of droppings were added and well beaten, and when the heat was suitable the bed was spawned, and in a few days earthed-up. When that bed was turned out a year afterwards one could still see the straws of the litter and the stubble, and over every straw the spawn had spread like a network. As already stated, we think horse droppings are the best, but we mention the above fact merely to show those short of the best materials that they may make the most of what they have. In fact, we do not see why every farmer who has an empty stall, a piece of shed unused, or a piece of a cellar unoccupied, should not have Mushrooms pretty well all the year round if he can obtain the material and exercise patience—that is, neither spawn too soon, nor earth-up too soon. Heat destroys ten times more beds than coolness and all other causes put together. To give too high a temperature to Mushroom spawn is just as wise as bringing a plant from alpine snows, and expecting it to flourish in a tropical hothouse.

The rains of Monday evening enabled us to roll and consolidate firmly the walks in the pleasure ground treated as alluded to last week.—R. F.

TRADE CATALOGUE RECEIVED.

William Paul, Paul's Nurseries, Waltham Cross, London, N.—*Bulb Catalogue for 1870.*

TO CORRESPONDENTS.

* * We request that no one will write privately to any of the correspondents of the "Journal of Horticulture, Cottage Gardener, and Country Gentleman." By doing so they are subjected to unjustifiable trouble and expense. All communications should therefore be addressed solely to *The Editors of the Journal of Horticulture, &c.*, 171, Fleet Street, London, E.C.

We also request that correspondents will not mix up on the same sheet questions relating to Gardening and those on Poultry and Bee subjects, if they expect to get them answered promptly and conveniently, but write them on separate communications. Also never to send more than two or three questions at once.

N.B.—Many questions must remain unanswered until next week.

TAN MANURE (*Subscriber*).—Spent tanners' bark used as a horse's bedding, and consequently mixed with his urine and droppings, is an excellent fertiliser. The fresher it is used the better.

KEEPING WALNUTS (*A Subscriber*).—When quite ripe and out of the green husk, put them in stone jars or zinc-lined boxes, in alternate layers with moderately dry sand, and keep them in a cold cellar.

PINE SAWDUST AS A MANURE (*J. N.*).—There is nothing in red Pine sawdust to render it injurious as a manure; and soaked and mixed as you mention with the excrements either of horses or pigs it would be a powerful and enduring fertiliser.

MALVERN HALL MELON (*W. S.J.*).—It is a scarlet-fleshed kind of fine flavour.

SEEDLING BRONZE PELARGONIUMS (H. E. A.).—Your seedlings are very pretty, but there are many like them, and they are not distinct from others now in cultivation either in the foliage or colour of the flowers.

SELECT PELARGONIUMS (A Subscriber).—*Show.*—Hercules, Llewellyn, Attraction, Archbishop, Captain John, Heribond, Hermit, (Foster), Emperor, Sœur de Charité, Progress, Empress, Maid of Honour, *Spotted Pelargoniums.*—Amy Robert, Guillaume Severyns, King Arthur, Eugene Daval, Landseer, Monsieur Rougère, Dr. Andry, Monsieur Boncharlat, Nabob, Spotted Gem, William Bull, Madame Charles Keteleer.

ZONAL GERANIUMS FOR POT CULTURE (Idem).—Jean Sisley, Lord Derby, Clipper, Surpasse Beauté de Suresnes, Provost, Leonidas, Glow, Rev. H. Dombraïn, Excellent, Warrior, Rose Rendatier, Cheitain.

HYBRID PEARL-FLOWER ROSES FOR POT CULTURE (Idem).—Antoine Ducher, Duchesse de Caylus, General Jacqueminot, John Hopper, Jules Margottin, Madame Victor Verdier, Mdlle. Bonnaire, Mdlle. Thérèse Lovet, Senateur Veisse, Victor Verdier, Fisher Holmes, Marechal Vaillant.

SELECTED FLOXES (Idem).—Madame Barillet, Mdlle. Hortimo de Tancenne, Comtesse de Chambord, Comtesse de la Tabouze, Monsieur Lienden, Monsieur C. Turner, Queen Victoria, Monsieur Malet, Madame Marie Saison, Madame Froment, Madame George Edith.

SELECTED ANTIARRHINCUS (Idem).—Algeria, George Gordon, Oheron, Rosa, Yellow Gem, Pretty Polly, Admiral, Grand Duke, Leopard, Nonpareil, Udine, Gladiator.

LILIUM LANCEFOLIUM (D. White).—Album and Rubrum are varieties of the same species.

WINTERING BREDDING GERANIUMS IN A MELON FRAME (An Amateur).—We do not consider that Melon frames, or indeed frames of any kind, are suitable for wintering such kinds of Geraniums as Cloth of Gold, Bijou, Stella, Flower of Spring, and Oak-leaved. To winter them properly they require a house or pit with means of applying fire heat in cold and dull moist weather, to keep out frost and expel damp. Wintering in cold frames is always attended with great risk of damping, the lights having very often to be kept closed on account of cold when the plants are damping off and require air. Some, however, are under the necessity of wintering them in cold frames, and we therefore advise you to choose the warmest, most sheltered spot you can find, and the site must be dry. Let the lights face the south, and slope well so as to throw off the wet rapidly, for when they are flat there is a danger of drip. Set the frame on bricks, having at least one course above the surrounding ground level, and leave between the bricks a space of about an inch. Fill coarse gravel or loose rubble to the level of the bricks, and then an inch or two of coarse ashes, and you can then surface with an inch of finer gravel for the pots to stand on. Place the plants in as small pots as can be done without reducing the roots to a very great extent, and set the pots on the ashes. If the soil be moist but not wet you will not need to water, but give air day and night when the temperature outside is above 35°. Early in December remove any leaves at all likely to damp, but not the fresh leaves and growing points, and with a sharp knife cut off any shoots or portions of shoots in which decay may have begun. This done, clear away every decayed leaf and return the plants to the frame, plunging the pots to the rims in dry cocoa-nut fibre refuse or coal ashes, with the finer particles sifted out. No water should be given however dry the soil. A dry fine day should be chosen for this preparation of the plants for the winter. Outside the frame, all round the sides and ends, place coal ashes, piling them up level with the under side of the light, or as high as you can without preventing the sashes being drawn off. In rainy weather tilt the lights at back, and whenever the weather is mild give air day and night. In frosty weather the lights will of course need to be kept on, and protecting material will often be necessary in addition, and it may remain on during the day when the temperature out of doors does not exceed 32°. In very severe weather you will need a covering of straw 6 inches thick in addition to a double thickness of mats. The straw should be dry and overhang the frame by 6 inches all round. This should only be resorted to in hard frost, and should remain on day as well as night as long as the temperature in the shade does not rise above 32°. On fine days exposure fully, give air in all mild weather, and pick off all decayed leaves.

COLEUS FOR BEDDING (Duncan McNeil).—The better kinds of Coleus are not suitable for the northern counties. The kinds most suitable are C. Verschaffelti, and Coleus Beauty of St. John's Wood. The latter is of free growth, and endures heat and cold well. To have good plants for planting out at the beginning of next June, and to give an effect at once, we put in the cuttings at this time singly in 3-inch pots, and strike them in a frame with a gentle heat. When struck remove them to shelves in a house having a temperature of not less than 45° in winter, keeping them dry and near the glass. In February we shift them into 6-inch pots, and in April into 9-inch pots, and commence hardening them off by the middle of May, by which time they will be fine plants, affording an effect at once. They are stopped in order that they may be of compact growth, and the tops, if inserted in a hotbed, will make small plants by June. However, in cold northern localities, the Coleuses are of little value, and unless planted out when strong and effective to begin with, they are best left alone, for small plants put out in the hope of becoming larger have but a small chance of doing so.

NAPOLITAN VIOLETS (Idem).—For blooming in winter these do not require bottom heat. Plant them in the frame early in October, after taking them up with balls. Light turfy loam with one-third leaf soil or well-decayed manure intermixed, will answer very well. The plants should be 6 inches from the glass, the distance from the soil to the glass being 9 or 10 inches. Russian Violets require the same soil. They cannot have too much air; but they should be protected from frost by mats or other covering in frosty weather.

REPLANTING TULIPS (Idem).—The bulbs having been left in the ground all summer, we should not advise their being taken up this autumn on the removal of the bedding plants. After lightly stirring the surface with a fork, give a top-dressing, about 1½ inch thick, of loam and leaf soil in equal parts. If you could have taken up your Tulips before they had made fresh roots, we would have advised replanting as soon as the ground had been manured and dug. The only advantage in taking them up would be in your being able to remove the offsets and small bulbs not likely to flower, and to enrich the soil. If they had begun to make fresh roots when taken up—the removal would be more injurious than beneficial.

BEST SEED (Idem).—The seed you have ripening from plants of last year's sowing will be equal to that you could purchase.

MARQUISE DE MORTMART (R. P.).—This is not a Rose of strong growth; indeed, few Roses of that shade of colour are. It is, however, well worth growing, and fine blooms have nice shell-shaped satiny petals. Weak blooms are certainly apt to be flat.

SUPERIOR HYBRID PEARL-FLOWER AND TEA ROSES OF THE LAST FOUR SAASONS (B. H. R.).—Of 1867.—Antoine Ducher, Black Prince, like Pierre Nottin; Horace Verneat and Annie Wood, both very good; Monsieur Noman and Princess Mary of Cambridge, two of the best pinks. Of 1868.—Boule de Neige, very good pillar Rose; Duke of Edinburgh, very fine colour; Christiane Nilsson, Elie Morel, François Fontaine, Madame la Baronne de Rothschild, one of the greatest acquisitions of late years; Pitord, Reine du Midi. Of 1869.—Erthe Baron, Emilie Hausburg, Julie Tonvais, Henri Ledechaux, Dupuy Janio, Desvieux Lamy, Monsieur Creyton, Marquise de Mortmart, Nardy Freres, Thyra Hammerich, and Victor le Bihan. Of 1870.—It has been a trying season to test this year's Roses. Candide, Charles Trauer, Comtesse d'Oxford, Ferdinand de Lesseps, Jules Scurie, Louis Van Houtte, Mdlle. Eugénie Verdier, Marquise de Castellane, Paul Neron, Reine des Beautés, and Thomas Methven. Teas of 1867, 1868, 1869, and 1870.—Madame Margottin, Clotilde, Reine du Portugal, Marie Sisley, Marie Ducher, Montplaisier, Belle Lyonnaise, and Catherine Mernot.

PEACHES (Y. W. Popham).—There is no such Peach as Dymond. Probably it is Diamond, a seedling raised by Mr. Veitch, of Exeter, some years ago. Since the rain my splendid crop of Peaches and Nectarines is swelling beautifully. (H.).—Mr. Staudish's Early Ascot is beautiful and excellent. It ripens soon after the Early York, which is still one of the best early Peaches. Early Victoria is much like it, but larger and very delicious. Early Alfred is also an early Peach of great beauty and excellence, and an excellent cropper. Lord Palmerston is a very large and fine Peach, not yet tasted. Too much praise cannot be given to Princess of Wales as a very large late Peach. In season here from the 24th to the end of September. It forms a good succession to Barrington, one of our best late Peaches. It has a creamy cheek with delicate pink suffusion. My trees are in famous triple bud, and the wood is hard and nearly ripe. In the Rose "Glimpses," page 144, read Blanche "Meru," and not "Meon."—W. F. RADCLIFFE.

DISEASED PEAR LEAVES (R. S. T.).—They are suffering from the parasitic fungus *Roestelia cancellata*. There is no remedy now, for picking off the leaves and burning them would be of no use, as the spores are shed. When the leaves fall collect them, pile off an inch depth of the soil around the tree, and burn all together. Paint the stem and branches with a mixture of clay and sulphur, look out next year for the first reappearance of the fungus, and pick off the leaves as fast as it appears upon them.

TERRA-COTTA GAS STOVES (Harcoll).—We have not seen the terra-cotta stoves of Mr. Bennet in use, heated by gas. We have no doubt that with the dish beneath supplied with water, the flame of gas regulated, and especially if argand burners are used, that there will be so little escape of gas, that the stove would do admirably for halls, corridors, &c., where plenty of air was admitted. We are informed that with argand burners, under such circumstances, there is no escape and no smell. For ourselves, if using the stove for plants, we would prefer a small pipe, even if less than a quarter of an inch in diameter, to go from the top of the stove into the open air. For your place a 4-shilling stove would do, but as it is always desirable to have enough of heat, the largest might be desirable. We are well aware that the heat will be more genial than from iron stoves. The water below is also an advantage.

WATERING VINES IN A CONSERVATORY BORDER (A. A.).—Water delivered from pressure, and if cold, is often not beneficial. We think if you examine the Vine roots you will find them overdry. Why not have a latticed path over the roots instead of the gravel path inside? Gravel is very deceiving in this respect, and you cannot easily water sufficiently without breaking it up. Watering the floor in your case will be safer than syringing the Vines.

FLOWER-GARDEN BORDER PLANTING (Kibbie).—You will find an answer to your inquiries at page 151. For such a narrow border three lines would be more effective than any composition. What you have will do very well if you can keep the *Tropaeolum* right by picking. We would greatly prefer a row of Scarlet Geraniums instead, and if cuttings are inserted now, as stated in "Doings of the Last Week" a fortnight ago, it would take little room in winter to hold about three hundred. Something like Tom Thunb, Little David, or Brilliant would be best, as not too high for *Calceolarias* at the back, and the variegated *Alyssum* in front, next the Ivy.

TRAINING MINIATURE APPLE AND PEAR TREES (Amateur).—We cannot advise you as to training your young grafted fruit trees as bushes or as pyramids, as both are good, and both have their advantages. You can have more plants as pyramids, but, on the other hand, the bushes fill the places best, instead of leaving room between, as with pyramids. In either case you must cut your own shoot, so as to secure a base, but perhaps it would be as well to defer that until the spring, as shoots made after cutting or stopping now would not be ripened. If resolved on pyramids, after forming a base, you must keep one leader instead of a number. On the whole we think the bush plan the more profitable.

SHADING POINSETTIA PULCHERRIMA AFTER POTTING (J. B.).—*Poinsettia pulcherrima* when fresh potted will be the better of a little shade. Afterwards, and especially in autumn, the plants can scarcely have too much sun light to ripen the terminal buds.

GIVING LIQUID MANURE TO STRAWBERRIES (Idem).—We give no manure water to fresh-potted Strawberry plants until the roots begin to touch the sides of the pots. Your pots must be large and the plants very fine if from a thousand pots forced you can gather a ton of fruit; that would be nearly 2½ lbs. from a pot.

GOLDEN, SILVER, AND HARESFOOT FERNS (A. Z.).—There are neither golden nor silver Haresfoot Ferns, but if you mean different species, then of *Gymnogrammas* there are the common golden and silver, but no species of them thrives in a greenhouse. There is a golden *Adiantum* (A. sulphureum), and also a silver one (A. scabrum), both of which succeed admirably in a greenhouse. The genus known popularly as Haresfoot Ferns is *Davallia*, of which *D. canariense*, *D. pyxidata*, *D. Lindleyi*, and *D. solida* will thrive in a greenhouse, the first named being the commonest species.

POTATOES (L. J. H.).—In the Borough and Farringdon Markets they are

especially sold in wholesale quantities by weight. The great railway Potato market is at King's Cross.

STRAWBERRIES LOSING THEIR COLOUR (*E. C., Oakham*).—We cannot tell how the Strawberries, after being planted two or three years, lose their colour—become whitish, though well flavoured. Probably in your shaly soil a good annual dressing of rich manure and a little soot would prevent it. If not, you must plant offener. The varieties we prefer are British Queen, Empress Eugénie, Dr. Hogg, and Keens' Seeding; but tastes differ, and so do varieties in different soils and climates.

BURNING SULPHUR IN A VINERY (*Dilemma*).—We cannot understand how anyone having a knowledge of plants could venture even to "burn a pinch of sulphur" in a vinery. The sulphurous acid formed by such burning is death to any part of a leaf that inhales it. The Vines, the leaves of which you have thus injured, will have their present crop deteriorated, and next year's crop lessened probably. Keep the air of the vinery moist, and do not remove any leaf that has a particle of green surface left; such leaves and new ones which will be formed probably may mature the crop.

ATLANTHUS GLANDULOSA (*F. D.*).—It is now very common. If you state what you wish to exchange, and what you require in return, we will insert your wishes in the exchange column if you enclose twelve postage stamps.

NAMES OF FRUITS (*A. M. F.*).—*Plums*.—1, Orleans; 2, Lucombe's Non-such; 3, Golliath; 4, No wood sent. *Apples*.—2, Margil; 3, Non-such. *Pears*.—1, Williams' Bon Chrétien; 2, Gansel's Bergamot; 3, Nouveau Poiteau; 4, Passe Colmar; 5, Striped Virgoulenise. Many of the Pears are too immature.

POULTRY, BEE, AND PIGEON CHRONICLE.

A TRIP INTO GLOUCESTERSHIRE AFTER POULTRY.—No. 2.

As I began to enter Stroud, it was easy to be seen that its inhabitants had determined to make their picturesquely situated town as gay-looking as possible. There was such a display of hunting that I began to think whether *that* was not its staple manufacture, until a motto over an arch recalled to my mind the truth, for its words were, "Success to our staple trade, superfine cloth." There were flags everywhere, and wreaths of evergreens, and garlands and festoons, which all told of the long and successful labour of many hands. Thankful am I to say that we were spared the almost inevitable fir trees in the streets, the only benefit of which is, that they are decorations which cost no trouble, while, on the contrary, the good Stroud people evidently had spared themselves no trouble. I rode under numerous arches, reading and commenting upon their various mottos—mottos religious and secular, mottos agricultural and commercial, and I said back what one said to me, "Happy to see you." A motto over a very telling arch, but somewhat hidden by its surroundings, puzzled me awhile. At first I read it as, "Success to the Gas," but could not conclude that gas was a recent introduction in the go-a-head borough of Stroud. Then I read it "Success to the Gals," and I thought, however right the feeling expressed, yet Stroud men might have been more gallant, and should have written "Success to the Ladies." I then noticed a little comma, and the puzzling word was no word at all, but "G. A. S.," which I presume meant "Gloucestershire Agricultural Society." Right through the town we go, and I always notice that in prosperous towns the respectable outlying part, the verge, the fringe so to speak, whatever be the scenery, is very pleasing to an eye that loves the subjects dilated on in "our Journal," for it is in this part that the inhabitants build villas, and make their homes beautiful with tree, shrub, and flower; and on the bright paths or green grass, or swinging on the gates, I see pretty little children with bright blue eyes, and bright locks, some very "golden fleeces," blowing in the breeze, their fathers so many happy Jasons, and cheeks, as on this day, a-glow with excitement, and eyes watching with delight the holiday-makers as they drive past. Truly there is no prettier sight in the world than a well-built, well-gardened English villa. A mansion often looks cold and desolate, a palace not unfrequently looks gloomy though grand, but an English villa looks a bright, happy, liveable place.

Having driven past several such villas, we reach Stratford Park, where the Show is held. "Bath and West of England, but smaller," is my exclamation as I enter. The Gloucestershire Agricultural Society held its first show in 1858, that was at Gloucester. Since 1862 it has been peripatetic, and now for the first time wandered to Stroud, and, I am told, is larger than it ever was before. There is also this year another improvement, particularly interesting to us of this Journal—a Poultry and Pigeon Show has been added. I understand that this decision was arrived at very late, but energy brought success.

There was energy and liberality in the Committee, for they gave a silver cup, and seven other cups came from various liberal persons or classes. Thus from all I saw and heard at Stroud, there seems to have been but one spirit pervading its worthy inhabitants and their neighbours, that of putting their shoulders to the wheel, and doing all they could, and doing it for the most part well.

The placards, "To the Show-yard," contained a pleasing deception, for instead of a yard, it was a goodly portion of a goodly park, and the shelter of its elms was as welcome as the trees were ornamental; among which, indeed, the white tents, large, middle-sized, and small, glistened in their whiteness. There was a long row of horse-boxes—extempore stables, and the horse-ring with the keen-eyed judges in the centre, and there were implements of course, though not many, and cattle and sheep, and unsavoury pigs, to become savoury after death.

I watched the horse-ring until a poultry catalogue was to be had, and then entered the tents, whose inhabitants crowded, cackled, and cooed. The Dorkings, as was their due at an agricultural show—for they are the farmer's and cook's fowls—stood first, and formed a very good class, a considerable number of pens being occupied by prizetaking birds, so that a loser of a prize here was not necessarily a bad pen; indeed the Dorkings were good, excellent, and most excellent. Dark Brahmas next, followed by their Light brethren. The first prize in the latter class went actually to chickens! The Cochins were good. The Spanish class was both large and good, and the cup pen in most excellent feather. Of the Game, the Duck-wings were a better class than the Black Reds. The Hamburgs were jumbled together; this a mistake. Polish were fairly numerous, and the "Any variety class" showed a very good pen of Black Hamburgs. Of the Game Bantams, I can only, as a true chronicler, say of them as a friend of mine said to a discharged servant upon her asking whether he could give her a character. He replied, "Oh! yes, I can give you a character, certainly, but not a character that will do you any good." The single cock class contained, besides the prize birds, an excellent Dorking cockerel belonging to the Rev. A. K. Cernwall, which extorted praise, but was, strangely enough, not even commended. Among the quacking, hissing, gobble, gobble birds, a curious circumstance occurred. Mr. Fowler's pen of Geese won the blue riband of the Show by "a fluke"—viz., the Stroud Licensed Victuallers' silver cup for the best pen of poultry in the Show. The Committee added a proviso that the same pen should not be eligible to take two cups. Mr. Fowler must indeed have been surprised, and I hope he will drink the health of his beautiful pen, and spare them from ever being eaten, they having won silver.

And now I come to the Pigeons. The Carriers were most excellent and numerous; Pouters few but good; and Mr. Fulton's Blues, which took the cup, were very good. The Tumblers, too, were good, as we should infer from the names of their exhibitors. Of the Runts I was pleased to see as many as five pairs. Fantails followed, and then a large and pretty "Any other variety class;" but among them I noticed only one pair of Nuns, those old and strikingly pretty Toys.

But home I must drive; so taking a loving stroll through the flower tents, and sitting listening to the Fusiliers' band, whose music made me forget time's flight, but kept me in a pleasing, dreamy, lotus-eater condition, while the groups of fair ladies, mothers and daughters, passed before my eyes like figures in a vision, at length I drew myself reluctantly away at the very most enjoyable time, the cool evening hour. Not soon shall I forget Stroud Show and the beautiful scenery around it. Of course there were a few amusing incidents, there always are at all shows. Thus there was the red-faced man who declared his pen of Ducks was the best in England, in truth it was the worst in the show. Then there was the non-poultry friend gently chaffing his poultry friend by saying, "Is it true that you send your fowls to the shows simply to save three days' keep?" I trust that a poultry show will always be attached to "G. A. S.," and be as good a one as this was at Stroud. Back we went through the same lovely scenery until darkness dropped its curtain around us, and I sat and thought all over, and tried to fix the beauty of all on my recollection.—WILTSHIRE RECTOR.

ROOSTING-PLACE FOR CHICKENS.

We begin now to perceive the approach of mid-autumn, and winter treads on its heels. Hitherto we have allowed our chickens to roost where they would, but it is time to think of

their being safely housed during the long nights. We are often told, and we believe it, that they never do so well as when they choose their own roosting-places; but we have to recollect that with the long nights come sharp morning frosts, cutting winds, and driving rains and sleet. These are very hurtful to fowls of all ages. A labouring man once said to us, "A good fire is half a bellyfull," and we believe him. In our country labourers buru turf, and when a man comes home from his work, damp, hungry, and tired, and the goodwife throws on a couple of large turves, stirs in the ashes, blows into them with the bellows till the dead heather on the turves ignites, and the flame roars and crackles up the chimney, lighting the house, and, through the windows, yards out into the road, though the meal be but potatoes, there is a sense of comfort that is to a certain extent satisfying. Compare the meal with one even of a better quality eaten standing in a ditch with your back against the bank to be screened from the rain and wind. It is the same with chickens in all respects but one. The man will choose the best lodging he can, the chickens will most obstinately stick to the first roosting-place, which is now getting positively injurious to them. They will hold to it just as a covey of Partridges cling to the stubble where they were bred in the corn, until no vestige of it remains. "Ah!" says one, "bring up your chickens like Partridges, they roost where they like." We are quite sure we rear more chickens in our artificial way, than Partridges, Pheasants, and Grouse do in following nature. Many of those who start with high expectations to-day will be able to tell us how, through the drought, covies have disappeared, that the wonderful promise of the third week in June has been badly kept, that pairs of old birds have been found where eighteens were expected, that want of water and scorching sun have done their work to the destruction of the breed in many places. The same would happen with our chickens if we allowed them to choose roosting-places for themselves, and as it is too late to do so after they have colds and incipient roup, they would soon follow the natural Partridges; and now cub-hunting begins, the litters are scattered and driven into fresh districts, and they soon find the roosters in the hedges or trees. But in many places the chickens roost in the rips after the hens have left them; in such a case the rips should be moved every day nearer to the house they are intended to occupy, till at last they are brought into it. The rips should then be taken away, and for some nights the chickens must be driven into the house; they will not take to it willingly. To do this now will save trouble and death hereafter.

There are many complaints about the inconvenience of numbers of young cocks now arriving at a troublesome age. We have for years made a pen about 20 feet by 12, with a warm brick and slated roosting-place, and we keep therein from fifteen to twenty cocks. They grow up there and do better than they would running about. They do not fight, and they give no trouble.

BONE DUST FOR CHICKENS.

In reply to those who desire a few further particulars regarding the use of this substance for rearing large birds, I desire to add the following:—I only recommend it for the large breeds, and my experience of it does not extend farther. For them it is certainly not injurious. I cannot conceive that it would be so for delicate varieties; for small fowls it is useless, except to give to adults during moulting time. In this way it is most valuable, supplying just the material wanted for the formation of new feathers. It must not be confounded with raw or new bones crushed, the effects being altogether different. Were raw bones given constantly the effect would be injurious and unhealthy stimulation and hastening of maturity; hence, these cannot be given regularly to pullets as they approach the laying age, though valuable in moderation for cockerels and adult fowls. The dry bone dust, on the contrary, retards maturity, keeping back laying, and maintaining the raw or leggy appearance, during which the birds grow. To have this effect, I repeat it ought to be given constantly in every feed of soft food, adding about a good heaped-up teaspoonful to every half-pint of meal.

The bone dust is not always precisely the same, and is not always easy to procure at all. Sometimes it is very dark-coloured, and has an offensive foetid smell, but is not injurious on this account, except that if given to laying fowls the eggs will taste "musty." Sometimes it is almost in fine powder, at others—and I like this best myself—it more resembles coarse meal. In this case the coarser splinters need not be

separated, as the birds will reject all too large for them. Some I got this season was the best I have had for some time, being nearly white and almost free from smell. I have also heard that bone sawdust, as obtained from workers in bone, has been found very good.

Finally, I never recommended this substance as a necessity for rearing fine birds. Hundreds of splendid fowls have been reared without it, and, probably, people with good runs and skilled feeders do not need it. But all my poultry-keeping is carried on under a host of difficulties. My largest pen or run is only 20 feet square, and all the others much less. Of grass, I have not, of course, a blade in my whole yard. How I manage under such circumstances I may, perhaps, say some other time; but my present point is this, that in such confined spaces I find a marked difference in the size of pullets, especially since I used the bone meal. I used to think 1 lbs. a good weight for a Brahma pullet four months old; now I can generally get 5 lbs. Further, I have letters since I first recommended it in my work on Brahmas, from some of our best-known exhibitors, stating similar effects in their experience, and I am convinced that to all who only have such small pens as poor "Nemo," the ingredient will be a real boon.—L. WRIGHT.

THE CRYSTAL PALACE POULTRY SHOW.

MAY I ask if it is the intention to repeat this year the Show held at the Crystal Palace? If so, is it not quite time the date were announced, that it may not clash with other exhibitions, as is likely to be the case if left until the last moment? The Birmingham and Bristol authorities have for some time past fixed their dates, and if the Committee of the Crystal Palace follow their example, it will probably prevent two or more important shows being held at the same time. I am sure many of your readers will be glad to know that the only exhibition in the vicinity of the metropolis will not be discontinued, and the large number of visitors at the last show gave ample proof of the interest taken in it by the public. Perhaps the late President or Secretary will oblige by stating if any steps are intended to be taken to repeat the show, or if, so far as they and the late Committee are concerned, it is decided to let the matter drop.—COLUMBA.

CLEAN-LEGGED WHITE BANTAMS.

We have had East Indian Ducks, Brown Red Game Bantams, and other varieties noticed as being much neglected, and deserving of encouragement from poultry committees. Being an admirer and breeder of White Bantams, I wish to introduce them to the notice of committees and others interested in them as being a variety nearly lost sight of; and if something be not done, and some encouragement held out for them, we shall soon lose sight of them in the show pen altogether. They have mostly to compete (with few exceptions) against the Black, Laced, and foreign varieties, and in most cases the prizes fall to Blacks. Being a breeder and exhibitor of Blacks, I have shown them successfully, at the same time I have to keep my White Bantams at home, knowing that Black would be preferred by the judges. Still I do not know why it ought to be so, for I consider White Bantams hardier, better layers, and better mothers; and what can look more beautiful than a clean satiny White Bantam? Being an old-established breed, I think it the duty of every White Bantam fancier to do his best for them. Out of twenty-three entries of Bantams "Any other variety, except Game," at Rochdale last week, there was not a single White clean-legged Bantam. I should be glad to hear the opinion of other fanciers; but I hope ere long we shall have at every show a separate class for Black Bantams, to which their numbers entitle them, and it would give a better chance of success for the poor, despised, and neglected—WHITE BANTAM.

WORSLEY AND SWINTON POULTRY SHOW.

THIS was held on August 25th in the Park at Worsley. The following awards were made by the Judges, Mr. R. Teebay, and Mr. John Douglas:—

DOBKINGS.—1 and 2, J. Stott, Healey, Rochdale. SPANISH.—1, C. W. Brierley, Middleton. 2, W. Parr. PATRIGOLD. COCHIN-CHINA.—Buff.—1, 2, and Cup, W. A. Taylor, Manchester. Partridge of any other colour.—1, W. A. Taylor. BRAHMA FOOTBALLS.—1 and 2, W. A. Taylor. *de. E. Leech, Rochdale. GAME.—Cock.*—1 and 2, C. W. Brierley. *Black or Brown Red.*—1 and 2, J. Carlisle. Early. 2, C. W. Brierley. *Any Colour.*—1, C. W. Brierley. 2, J. Mitchell, Moseley, Birmingham. HAMBROONS.—Golden-pencilled.—1, T. Wrigley, jun., Tonge Hall, Middleton. 2, W. Parr. *Silver-pencilled.*—1 and 2, W. Parr.

Golden-spangled.—1 and 2, F. Brierley, Heywood. Silver-spangled.—1 and 2, W. Farr. Bantams.—Game.—1, T. Gregory, Little Hulton. 2, L. Binney, Manchester. Any Variety.—1, S. & R. Ashton, Roe Cross, Mottram. 2, T. Stone, Worsley. ANY BREED.—1, P. Unsworth, Lewton, Newton-le-Willows. 2, L. Binney (Houldens). GOSLINGS.—1, E. Leech. 2, S. H. Stott, Rochdale (Toulouse). DUCKS.—Aylesbury.—1, E. Leech. 2, W. Parr. Rouen.—1, J. Scottoun, Little Bymon, Lewton. 2, T. Wakefield, Golborne, Newton-le-Willows. TURKEYS.—1, E. Leech. 2, W. Whitte, Worsley.

PIGEONS.

CARRIERS.—1 and 2, E. Horner, Harewood. FOUTERS.—1 and 2, E. Horner. TRUMPETERS.—Short-faced.—1, E. Horner. 2, J. Fielding, jun., Rochdale. Common.—1, E. Horner. BARBS.—1 and 2, Capt. H. Heaton, Worsley. *he*, J. Fielding, jun.; Capt. H. Heaton. OWLS.—1 and 2, J. Fielding, jun. *he*, G. A. Thom, Pendleton. JACOBS.—1 and 2, E. Horner. TERBITS.—1 and 2, J. Fielding, jun. *he*, H. Yardley, Birmingham. FANTAILS.—1, H. Yardley. 2, E. Horner. TRUMPETERS.—1, E. Horner. 2, P. Unsworth. DRAGONS.—1, P. Unsworth. 2, H. Midgley, Swinton. ANY OTHER VARIETY.—1, J. Fielding. 2, E. Horner.

WHITWORTH AND ROCHDALE POULTRY SHOW.

The following awards were made at this Show, held on the 24th ult.:

SPANISH.—Cock.—1, F. & C. Haworth, Newfield, Haslingden. 2, H. Beldon, Goitstock. *c*, F. & C. Haworth; T. C. & E. Newbitt, Epsworth. Hens.—1, F. & C. Haworth. 2, J. Brown, Putney Heath. Cockerel.—1, C. W. Brierley, Middleton. 2, E. Horner, Sheffield. Pullets.—1, H. Brown, Surrey. 2, E. Brown. *c*, C. W. Brierley.

COCHINS.—Cinnamon and Buff.—Cock.—1 and 2, W. A. Taylor, Manchester. Hens.—1 and 2, W. A. Taylor. 2, C. W. Brierley. Cockerel.—1, W. P. Rylands, Edington. *he*, C. Sidgwick, Kingleigh. *c*, J. Watts, Kings Heath, Birmingham. W. A. Taylor. Pullets.—1, C. Sidgwick. 2, W. A. Taylor. *he*, J. Stretch, Ormskirk; W. A. Taylor; C. Sidgwick. Any other Variety.—Cock.—1 and 2, W. A. Taylor. Hens.—1 and 2, W. A. Taylor. Cockerel.—1, W. A. Taylor. 2, C. Sidgwick. *he*, J. H. Dawes, Birmingham. Pullets.—1, W. A. Taylor. 2, C. Sidgwick. *he*, T. Stretch.

BRAHMAS.—Dark.—Cock.—1, J. H. Pickles, Birkdale, Southport. 2, H. Dowsett, Hoxley. Hens.—1 and 2, J. H. Pickles. Cockerel.—1, Mrs. Burrell, Ipswich. 2, W. A. Taylor. *he*, C. Lyland, Warrington. W. A. Taylor. Pullets.—1, Mrs. Burrell. 2, W. A. Taylor. Light.—Cock.—1, F. Crook, Forest Hill. 2, J. Pares, Postford, near Guildford. Hens.—1, H. Dowsett. 2, F. Crook. Cockerel.—1, H. Dowsett. 2, J. Watts. Pullets.—1, T. Matthew, Hurstend, Rochdale. 2, M. Lemo, Markate Street, Dunstable.

GAME.—Black or Brown Red.—Cock.—Cup, T. Statter, jun., Whitefield, Manchester. 2, C. W. Brierley, W. Boyes, Beverley, Yorkshire; C. W. Brierley; C. Chaloner. *he*, C. Chaloner. Hens.—1, W. Brierley. 2, C. Chaloner. *he*, W. Boyes; T. C. & E. Newbitt. Cockerel.—1, C. Chaloner. 2, C. Chaloner, jun. *he*, C. Chaloner. Pullets.—1, J. F. M. Fitton, Humblefield, Halifax. 2, G. and Sutcliffe, Queensbury. *he*, Stott & Booth, Hantley Brook, Bury; C. W. Brierley; C. Chaloner. Any other Variety.—Cock.—1, C. Chaloner. 2 and *he*, W. Boyes. Hens.—1, C. Chaloner. 2, C. W. Brierley. Cockerel.—1, C. Chaloner. 2, J. F. M. Fitton. Pullets.—1, C. Chaloner. 2, J. F. M. Fitton (Duckwing). *he*, C. W. Brierley.

BOULARDS.—1 and 2, H. Beldon. Hens.—1 and 2, H. Beldon. Cockerels.—1, H. Beldon. 2, H. Pickles, jun. Pullets.—1 and 2, H. Pickles, jun. *he*, H. Beldon.

HAMINGAS.—Golden spangled.—Cock.—1 and 2, H. Pickles, jun. *he*, Miss C. E. Fulmer, Lighthorne, Warwick. Hens.—1, H. Beldon. 2, J. Buckley, Taunton, Ashton-under-Lyne. *he*, T. Walker, jun., Denton. Cockerel.—1 and 2, J. Buckley. *he*, T. Walker, jun.; J. Andrew, Waterhouses, Ashton-under-Lyne. Pullets.—1, T. Schales, Hollingwood. 2, T. Walker, jun. *he*, T. Walker, jun.; J. Chadderton, Hollingwood. 2, Brierley, Heywood. Silver-spangled.—Cock.—1, J. Fielding, Newchurch. 2 and *he*, H. Beldon. Hens.—1, H. Beldon. 2, H. Beldon. *he*, J. Fielding, Newchurch, near Manchester. Cockerel.—1, J. Fielding. 2, H. Pickles. *he*, G. & J. Duckworth, Blackpool. *c*, J. H. Howe, Ashton & Booth, Broadbottom, Mottram. Pullets.—1, J. Fielding. 2, Ashton and Booth. *he*, H. Beldon. Golden-pencilled.—Cock.—1, H. Pickles. 2, H. Beldon. Hens.—1, H. Beldon. 2, H. Pickles. Cockerel.—1, T. Wrigley, jun., Tonge. 2, S. Smith, Bhowman, Halifax. *he*, H. Beldon; H. Pickles. Pullets.—1 and *he*, T. Wrigley, jun.; S. Smith. Silver-grey.—Cock.—1, H. Pickles. 2, H. Beldon. Hens.—1, H. Beldon. 2, H. Pickles. Cockerel.—1, H. Beldon. 2 and *he*, H. Pickles. Pullets.—1 and *he*, H. Pickles. 2, H. Beldon. Black.—Cock.—1, H. Beldon. 2, T. Walker. *he*, C. W. Brierley. Hens.—1, T. Walker. 2, H. Beldon. *he*, H. W. Hingworth. Pullets.—1 and 2, C. Sidgwick. *c*, W. Collyer.

DORINGS.—Cock.—1, S. H. Stott. 2, T. Statter, jun. Hens.—1, J. Stott. 2, J. Watts. Cockerel.—1 and 2, J. Stott. Pullets.—Cup, T. E. Kell, Weltherby. 2, J. White, Warley.

FRENCH FOWLS.—Cock.—1, H. Beldon, Goitstock. 2, C. Morris, Hohnleigh Crossdale. Hens.—1, H. Beldon. 2, W. O. Quibell, Newark. Cockerel.—1, W. O. Quibell. 2, W. Gamon, Chester. *he*, Mrs. M. Seamons, Hartwell, Aylesbury (Creve-Coeur). Pullets.—1, W. O. Quibell. 2, Mrs. M. Seamons (Creve-Coeur). *he*, Mrs. E. Williams, Henlys, Berrier (Creve-Coeur). ANY OTHER VARIETY EXCEPT BANTAMS.—Cock.—1, Mrs. Burrell. 2, Messrs. Kitchen & Co., Farnscole, Blackburn. Hens.—1, Mrs. Burrell. Cockerel.—1, J. Hinton, Warminster (Malay). 2, Mrs. M. Seamons (Silky). Pullets.—1, J. Hinton (Malay). 2, Mrs. M. Seamons (Silky).

GAME BANTAMS.—Black or Brown Red.—Cock.—1, J. Crosland, Wakefield. 2, W. F. Entwistle, Cleckheaton (Black-breasted Red). Hens.—1 and 2, J. W. Morris. Any other Variety.—Cock.—1, T. Dymson, Halifax. 2, W. F. Entwistle. Hens.—1, T. Barker, Hartley. 2, W. F. Entwistle. Any other Variety except Game.—Cock.—1, H. Beldon. 2, A. Stott, Rochdale. Hens.—1, J. Walker, Halifax. 2, M. Lemo.

DUCKS.—Aylesbury.—Drake.—Cup, E. Leech. 2, J. K. Fowler. *he*, Mrs. M. Seamons. Ducks.—1, E. Leech. 2, Mrs. M. Seamons. *he*, Mrs. M. Seamons; J. K. Fowler. Rouen.—Drake.—1, T. Statter, jun., Stand Hill, Whitefield, Manchester. 2, W. F. Stott, Rochdale. *he*, E. Leech; S. H. Stott; H. B. Smith, Broughton, Preston. Ducks.—1, E. Leech. 2, T. Statter, jun. Drake and Duck.—1, C. W. Brierley. 2, H. B. Smith. *he*, R. Ashton; T. Statter, jun. GREENS.—White.—Cocker.—1 and 2, E. Leech. *he*, T. Statter, jun. *he*, E. Leech. 1 and 2, E. Leech. *he*, Mrs. M. Seamons. *c*, T. Statter. Goslings.—Cup, E. Leech. 2, Mrs. M. Seamons. *he*, E. Leech; G. Husler, Stillmicklet, York. Grey.—Gander.—1, J. K. Fowler. 2, E. Leech. *he*, Mrs. M. Seamons; T. Statter, jun. *c*, J. White, Whiteley, Netherton, near Wakefield. Geese.—1, G. Husler. 2, E. Leech. Goslings.—1, E. Leech. 2, Mrs. M. Seamons. *he*, J. K. Fowler.

TURKEYS.—Cock.—1 and 2, E. Leech. *c*, H. Crossley, Halifax. Hens.—Cup, E. Leech. 2, F. E. Richardson, Bramshall, Uttoxeter. *c*, H. Crossley. Poults.—1 and 2, E. Leech.

SELLING CLASS.—Cock.—1, C. W. Brierley. 2, J. Watts. *c*, E. Leech. Hens.—1, Barch & Boulter, Sheffield. 2, H. Brown. *he*, F. & C. Howarth; H. Beldon. H. Dowsett. *c*, W. A. Taylor.

COTTAGERS' CLASSES.—GAME.—Cock.—1, P. Leech, Rochdale. 2, A. Milnes, Rochdale. Hens.—1, J. Whitehead, Littleborough, Rochdale. 2, A. Milnes. 2, P. Leech. COCHINS.—1, W. Trevor, Rochdale. 2, J. Pickup, Rochdale. SPANISH.—1, J. Pickup. 2, S. Hill, Whitworth. BRAHMA.—1 and 2, W. Trevor. HAMBUCKS.—Pencilled.—1, J. T. & J. Stott, Warley. 2, J. Law, Rochdale.

Spangled.—1, J. Greenwood, Rochdale. 2, S. Wrigley, Broadhaugh. Black.—1, J. Law. 2, J. & B. Rizer, Rochdale. ANY OTHER VARIETY.—1 and 2, J. Butterworth, Whitworth, Rochdale. BANTAMS.—1 and 2, A. Milnes. Game.—1, T. Lively, Rochdale. 2, J. Butterworth. Goslings.—1, J. Butterworth. 2, T. C. Walker, Spalden. DUCKS.—White.—1, J. Buckley, Rochdale. 2, J. W. Simpson, Greave, Rochdale. Any other Colour.—1, G. Healey, Two Bridges, Rochdale. 2, W. Lamb. TURKEYS.—1, T. Spawford.

PIGEONS.

PORTERS.—Red or Yellow.—Cock.—1, 2, and 3, R. Falton, Deptford. *he*, J. Hawley, Bingley (Red. 2); E. Horner, Harewood. Hens.—1 and 2, R. Falton. 3, E. Horner. Any other Colour.—Cock.—1, E. Horner. 2, R. Falton. 3, J. H. Harvey, Sheffield. *he*, S. Robson, Brotherton, Ferry-bridge; R. Falton. Hens.—1, E. Horner. 2 and 3, E. Falten. *he*, R. Falton. 3, J. H. Harvey.

CARRIERS.—Black.—Cock.—1, J. W. Wiltshire, West Gorton. 2, R. Falton. 3, E. Horner. *he*, H. Yardley, Birmingham; E. Horner (2). J. Ord, London (2); R. Falton. Hens.—1, 2, and 3, R. Falton. *he*, H. Yardley; E. Horner; J. C. Ord (2). Any other Colour.—Cock.—1, F. Wiltshire, West Gorton. Equal 1, R. Falton. 2, E. Horner. *he*, B. Consterdine, Littleborough, Rochdale; J. C. Ord; R. Falton. Hens.—1 and 2, R. Falton. 3, E. Horner. *he*, J. C. Ord.

TRUMPETERS.—Almost.—1, J. Fielding, jun., Rochdale. 2, F. W. Wiltshire. 3, E. Horner. *he*, F. W. Wiltshire; J. Ford, Monkwell Street, London, E.C. 2; R. Falton (2); J. H. Harvey. *c*, F. Kov, Beverley. Falde or Beard.—1 and 2, J. Fielding, jun. 3, R. Falton. Any other Variety.—1, R. Minnett, jun., Healey, Rochdale. 2, J. Hawley. 3 and *he*, R. Falton.

OWLS.—Foreign.—1 and *he*, J. Fielding. 2, R. Falton. 3, P. H. Jones, Fulham. English.—1, J. Hawley (Blue). 2, J. Thresh, Bradford. 3, E. Horner. *he*, A. Jackson, Heaton, Bolton-to-Moor.

BARBS.—Black.—1 and 2, Capt. Heaton, Worsley, Manchester. 3, F. Fifth, jun., Dewsbury. *he*, E. Horner. R. Falton (2). *c*, E. Horner. Any other Colour.—1, Capt. Heaton. 2, J. Fielding. 3, A. Maignall, Lower Proughton.

TURBITS.—Red or Yellow.—1, J. Fielding, jun. 2, E. Horner. 3, H. Yardley. Any other Colour.—1, J. Fielding, jun. 2, H. Yardley. 3, T. C. & E. Newbitt, Epsworth. *he*, J. Hawley. *c*, E. Horner.

NUSS.—1, H. Yardley. 2, Miss R. C. Frow, Kirkcaldy.

JACOBS.—Yellow.—1 and 2, E. Horner. 3, R. Falton. *he*, T. C. & E. Newbitt. Any other Colour.—1, E. Horner. 2, E. E. M. Royle, Greenhill, Rochdale. 3, B. Van Haansbergen, Newcastle-upon-Tyne. *he*, T. C. & E. Newbitt.

ANTWERPS.—Medal.—E. Horner. 2, W. A. Taylor. 3, J. Crosland, Wakefield. FANTAILS.—1, E. Horner. 2, T. C. & E. Newbitt. 3 and *he*, J. Bailey & Sons, Mount Street, Grosvenor Square, London.

DRAGONS.—Blue.—1 and 2, H. Yardley. 3, E. Horner. *he*, W. Gamon, Chester. Any other Colour.—1, J. C. Ord. 2, H. Yardley. 3, A. W. Wren, Lowestoft. *he*, J. Watts; R. Falton; C. Bulpin.

TACONETS.—1, E. Horner. 2, W. B. Van Haansbergen. 3, J. Hawley. *he*, S. Robson; J. Fifth, jun.; A. Ashton, York.

MAGPIES.—1, F. Horner. 2, T. C. & E. Newbitt. 3, W. Kitchen. ANY OTHER VARIETY.—1, E. Horner. 2 and 3, J. Bailey & Sons. *he*, H. Yardley.

SELLING CLASS.—1, C. Abton, York. 2, F. W. Zurborst, Dublin. 3, E. Horner. *he*, F. Key; J. Fifth, jun.; T. Statter. Half; J. Watts; J. H. Harvey, Sheffield; J. Kershaw, Rochdale (2).

RABBITS.—Lop-eared.—1, A. H. Easton, Hull. 2, E. Vaughan, Birmingham. *he*, G. Johnson, Kettering (2). Silver-grey.—1, E. E. M. Royle, 3, S. G. Hudson, 2, S. G. Hudson (Dutch). Selling Class.—1, E. E. M. Royle. 2, G. Johnson.

JUDGES.—Poultry: Mr. Richard Teebay, Falwood, Preston; Mr. John Douglas, Clumber; and Mr. Edward Hewitt, Sparkbrook, Birmingham. Pigeons: Mr. F. Esquilant, Brixton; and Mr. J. Charlton, Trafalgar Street, Bradford. Rabbits: Mr. Richard Teebay.

I soon found myself amongst the Rabbits, some of which I beheld for the first time, others were familiar to my eyes; very well they looked with the sun shining on them, but not so much as to injure or annoy. In my opinion the arrangements were good; the pens were roomy and all that could be desired with one or two exceptions. A little straw or hay would have been a comfortable addition. I do not care to see so much green food given Rabbits from twenty to forty hours from their comfortable hatches where, judging from the animals' appearance, they had been abundantly supplied with better fare. I am sure the steward in charge will promise better things for next year.

The show of Rabbits was quite a success, about twice as many being shown as in the preceding year, and I see no reason why Rochdale and its twin sister Middleton should not have the best exhibitions of Rabbits in Lancashire. Mr. R. Teebay was the Judge, and with perhaps one or two exceptions gave most satisfactory awards. Of Lops there were nine entries. The splendid Black and White buck of Mr. A. H. Easton, Hull, justly deserved the position which he took here, as at many other shows, as a cup-winner; his ears were 22½ inches by 5½. The second prize was given to Mr. E. Vaughan, Market Hall, Birmingham, for a Yellow and White Rabbit, eleven months old, with ears 22 inches long by nearly 5 inches wide. The highly commended specimen from Mr. G. Johnson, Wood Street, Kettering, was good. Of Silver-Greys there were eleven entries of good, well-silenced specimens, and the first prize and a high commendation were given to Mr. E. M. Royle, of Greenhill, Rochdale, and the second prize and a high commendation to Mr. S. G. Hudson, Paragon Street, Hull, for specimens which were all that could be desired. I rather incline to the belief that the specimens most to be appreciated are those most perfectly silenced, and in this particular some beautiful Rabbits were shown. The Himalayans (six entries) were not quite so perfect as I could have wished. The first-prize specimen from Mr. B. S. Rothwell, Rochdale, and the second-prize one from Mr. James Boyle, jun., of Blackburn, were the best in some important points; yet one shown by Mr. Butterworth, Rochdale, if not equal to its more fortunate neighbours, which I rather incline to think it was, at least deserved high commendation. Strange to say, no high commendations were given in this class, yet the Silver-Greys could boast of two. In the class for "Any other Variety" there were eleven entries. An Angora, well nosed, from Mr. T. Schofield, 140, Drake Street, Rochdale, was first; the second prize going to a good Dutch Rabbit from Mr. Hudson. This little animal seemed quite proud of its grey coat and white collar. A high commendation was given to a White Angora from Mr. Joseph Butterworth, Indle Pasture,

near Rochdale. In the Selling Class (seventeen entries), a Silver-Grey, from Mr. E. M. Royds was first; the second prize going to a Loop-ear from Mr. G. Johnson, of Kettering.

The entries of Rabbits numbered fifty-four against some twenty-six last year, and let me hope the Committee, with this fact before them, will be induced to give a class more for the Angora, and not mix it up with others as this year. I feel sure the experiment will be no pecuniary loss, but that it will attract more entries to the Rabbit section of the Show, which visitors seem also to have so much pleasure in beholding.—C. K.

LYTHE POULTRY SHOW.

THE pleasant little village of Lythe, situated about four miles north-west of the now fashionable watering place Whitby, held its fourth annual Poultry Show on August 26th. The exhibition was highly creditable, both as to the number of entries and the quality of the birds, and it is not too much to say that some of the Cochins exhibited at this little village gathering were of sufficient merit to make a mark in any show in England.

The Rev. T. Phillips, Robin Hood's Bay, and W. Stonehouse, Esq., of Whitby, were Judges, and made the following awards:—

BRAHMAS.—1, Mr. Corney, Whitby. 2, Mr. Booth, Lythe. *Chickens*.—1, Mr. Corney. 2, Mr. Stephenson, Whitby. SPANISH.—1, Mr. Crowther, Lythe. 2, T. Clemmitt, Lythe. *Chickens*.—1, T. Clemmitt. 2, Mr. Stephenson. COCHIN-CHINAS.—1, J. Booth, Lythe. 2, M. G. Greenbury, Whitby. *Chickens*.—1, T. H. Readman, Whitby. 2, Mr. Elliott, Lythe. GAME.—1, Mr. Dickenson, Lythe. 2, Mr. Pringle, Epton. *Chickens*.—1, Mr. Dickenson. 2, E. Noble, Whitby. HAMBURGHS.—*Golden-spangled*.—1, J. P. Luss, Sandson. 2, J. Cooper, Mickleby. *Silver-spangled*.—1, Mr. Pickering, Barnby. 2, T. Kidd, Lythe. *Golden-pencilled*.—1, Mr. Stewart, Whitby. 2, J. W. Boyes, Lythe. *Silver-pencilled*.—1, T. H. Readman. 2, Mr. Pickering. *Gold or Silver-spangled Chickens*.—1, T. Kidd. 2, J. Pymus. *Gold or Silver-pencilled Chickens*.—1, Rev. R. A. White, Whitby. 2, T. H. Readman. BARBDOOR FOWLS.—1, Mrs. Wellburn, Barnby. 2, A. Welford, Brock Riggs. *Chickens*.—1, G. Barker, Epton. 2, Mrs. Wellburn. ANY OTHER VARIETY.—1, Percival, Whitby. 2, Mr. Dickenson. *Chickens*.—1, T. Percival. 2, Mr. Booth. *Cock*.—1, Mr. Speedy, Whitby. 2, R. White, Lythe. *GEESE*.—1, Mr. Kerr, Deep Grove. 2, Mr. White, Lythe. *DUCKS*.—1, R. Dulong, East Row. 2, Mrs. Harland, East Row. LOCAL FOWLS.—*Chickens*.—*Lane Roads*.—1, Mr. Elliott. 2, Mr. Crowther. *Small Ducks*.—1, T. Kidd. 2, R. Thompson.

MEIGLE POULTRY SHOW.

THIS was held on August 24th. The following are the awards:—

DORINGS.—*Chickens*.—1 and Cup, Mrs. A. Bruce, Westhill. Airdie. 2, D. Gellatly, Meikle. *Geese*.—1, G. Anderson, Blairgowrie. SPANISH.—*Chickens*.—1, P. Simpson, Epton. 2, J. W. Will, 3, Mrs. Anderson, Meikle. BANTAMS.—*Chickens*.—1, J. W. Will. 2, J. Anderson. GAME.—*Chickens*.—1, D. Harley, Edinburgh. 2, W. Meldrum, Forfar. *Geese*.—1, K. Nicoll, Carnoustie. 2, J. Anderson. COCHIN-CHINAS.—*Chickens*.—1, J. W. Will. 2, D. Gellatly. HAMBURGHS.—*Golden*.—*Chickens*.—1, G. Craithness, Carnoustie. 2, J. W. Will. *Silver*.—1, J. W. Will. 2, J. Macandrew, Carnoustie. BANTAMS.—*Chickens*.—1, J. Anderson. 2, J. A. Dempster, Stirling. ANY OTHER VARIETY.—*Chickens*.—2, Miss A. Anderson, Meikle. ANY DISTRICT VARIETY.—1, T. Raines, Stirling. 2, W. Meldrum, 3, J. W. Will. *Chickens*.—1, G. Cuthill. 2, P. Raines. *Geese*.—1, Mrs. A. Bruce. SELLING CLASS.—1, J. Porter, jun., Myreside. 2, P. Simpson. 3, W. Simpson, Cardean. *DUCKS*.—1, *Ighbury*.—1, D. Gellatly. 2, Mrs. A. Bruce. *Rouen*.—1, A. Easson. 2, J. W. Will. *GEESE*.—1, Mrs. Barclay, Simprin. 2 and 3, Mrs. Ballingall, Cookston. TURKEYS.—1, Mrs. Barclay. 2, Lord J. F. G. Hallyburton.

DISTRICT PRIZES.

DORINGS.—1, G. Allan. 2, D. Gellatly. 3, Mrs. A. Bruce. *Chickens*.—1 and 2, Mrs. A. Bruce. 3, J. Sinclair, Drumkillo. *Geese*.—1, G. Allan. SPANISH.—1, Mrs. Anderson. 2 and 3, A. Shepherd, Meikle. *Chickens*.—1 and 2, Tea Service, D. Gellatly. 3 and 4, Mrs. Anderson. ANY OTHER VARIETY.—1 and 3, D. Gellatly. 2, Miss A. Anderson. *Chickens*.—1 and 3, D. Gellatly. 2, Mrs. Lamond, 3, G. Cuthill. 4, J. Porter, jun., Myreside. 5, G. Allan. 6, G. Cuthill. 7, A. Bruce, Hill. *Chickens*.—1, Mrs. A. Bruce, Westhill. 2, W. Simpson. 3, G. Cuthill. *Geese*.—1, Mrs. A. Bruce, Westhill. 2, W. Simpson. 3, G. Cuthill. *Chickens*.—1, Mrs. A. Bruce, Westhill. 2, W. Simpson. 3, G. Cuthill. *Geese*.—1, 2, and 3, A. G. McNeil, Coupar Angus (Owls, Turbits, and Tumblers).

CITY COLUMBIAN SOCIETY.

ON Thursday last, August 25th, the City Columbian Society held its first show for the season at the Crown and Cushion Tavern, London Wall. The meeting was well attended by members and friends from Ireland and Scotland, as well as from all parts of England, and great was the suspense of several who were eagerly watching every bird as it was put in the pen to catch the first glimpse. The birds shown were quite up to the average of quality for which this Society is celebrated, and several of them will be seen carrying off high honours at some of the leading shows when they get a little older. It is to be regretted that the committees of public shows do not offer prizes for young birds. I feel assured the entries would repay the prize money, and would be a very attractive feature.—J. F.

BEE-KEEPING AT MANCHESTER IN 1870.

THE present season has been, as a whole, somewhat unfavourable for bees in this neighbourhood. The honeydew so abundantly collected last year, made the honey very impure and rather unhealthy. Owing to the long winter, cold spring, and impure honey, many hives were weak in numbers, in other words, had only a small population in March and April; indeed, many weak hives of bees did not survive the cold spring months, and the strong lives of bees which outlived the severe

winter and spring did not swarm early. This year there were very few swarms in May. I had only one, all the rest were June swarms. Usually most of our stocks swarm in May. Some seasons bees are loth to swarm even after they are ready; but this year all the hives that swarmed did so freely, many of them yielding second swarms.

Notwithstanding the length of time without rain, very little honey was found in flowers this season, save during the first three weeks of June and this month (August). Still, swarms kept themselves, and needed but little feeding. During the fair month of July, and in the absence of cloud or rain, hives generally became much lighter, breeding was discontinued, white drones were torn out of their cells and cast out, and drones were massacred. The drought and easterly winds continued to the loss and discouragement of bee-keepers. I had then upwards of 2,000,000 of my faithful and industrious servants near starvation point. Their commissariat stores had to be thought of. A favourable balance sheet this year was but a remote idea, if not quite out of the question. Soon—very soon 14 lbs. of sugar per day will be required to keep them alive; 28 lbs. would do it better. A twig of heather just bursting into blossom was sent from the moors. Well, heather is hardy, and not easily affected by weather. Perhaps it will yield honey while the wind is easterly. Let me try my bees there? Away they go to grouseland about the end of July and beginning of August, fifteen hives at a time every two or three days. The bees began work at once, and before the last lot arrived the first one had gained in weight several pounds per hive.

Yesterday (August 23rd) I went to see them, and, arriving about 11 a.m., I found them busy, and collecting honey rapidly. My May swarm, the best, was first uncovered and weighed; its weight was just 95 lbs., and its mother hive standing by its side was 82 lbs. Some swarms weighed 80 lbs., some 70 lbs., some 60 lbs., and some 40 lbs. At 3 p.m. the best swarm was again weighed, and found to be just 98 lbs., with many bees out at work. Some of the best hives have gained from 50 to 60 lbs. each during the last three weeks. Grand results!—a fair harvest of honey without a speck of impurity, a favourable balance-sheet after all, and the lightest of the hives have ample stores for themselves if kept for stocks.—A. PATTENREW.

BEEES BUILDING OUTSIDE THEIR HIVE.

My bees this year seem to have behaved strangely. First, I have a common straw hive with a square box at the top, the whole enclosed in a wooden stand, for the sake of warmth and shelter in winter. In order to take the box of honey from the top of the hive, I opened the door of the outer case, and found that my bees had not only filled the small square box at the top of the hive which I was going to remove, but had also made large combs filled with honey outside the box, and on the top of the straw hive (inside the outer case), so that I had some difficulty in detaching the box of honey, which when emptied was put back again. The combs outside still remain, and the bees continue working. Secondly, Another straw hive, also inside a bee case, had a glass super put on, and over that a small straw hive to keep out the light, and on opening the door of the case I find likewise outside the glass super, and inside the little straw hive (put on, as I said, to keep out the light), the bees are working combs. Is not this unusual?—C. R.

[Bees when pressed for room will extend their combs in any direction, and sometimes take possession of the outer cases intended only for the protection of their lives. All such combs should now be removed, and those portions which are available carefully preserved until next year, when they will be found useful either as guide combs or decoy combs for glasscs and supers, and when, also, somewhat more care should be taken to afford the little labourers sufficient accommodation.]

THE BEE SEASON IN SCOTLAND.

WE have now arrived at nearly the close of the bee season of 1870. In Scotland it has, on the whole, been one of a very unsatisfactory character. A cold, dry, and ungenial spring succeeded a very protracted and unfavourable winter, in which, as I formerly remarked, many weak hives, otherwise well provisioned, succumbed. The weather at the commencement of summer was more propitious, and things began to look more hopeful, but notwithstanding a continuous track of apparently

fine weather, yet further progress was not so manifest as could be wished. As the season advanced this became even more evident by a want of activity among the bees, a deficiency of pollen and honey in the flowers, and a consequent falling-off in breeding and general advancement. How is this to be accounted for? No doubt the long prevalence of dry weather operated adversely on vegetation. I think these two past seasons furnish irrefragable evidence that very dry weather is not the best for bees. For the secretion and exudation of the nectar in flowers it is necessary that there be a certain quantity of moisture. Warm weather and genial showers are the indispensable requisites for a thriving apiary, and hence in many localities I have lately visited there is both a deficiency of swarms and flower honey. There are exceptions, no doubt, but I ascribe these to the circumstance that the fall of rain was very unequally distributed in Scotland—there being plenty in some parts of the country, and a scarcity in others. For myself I have had very few natural swarms this summer, and very little flower honey in supers. It is, perhaps, yet too early to estimate the amount of honey collected at the heath. This, of course, is one of the best of honey-yielding plants, and considering the luxuriance and abundance of the crop this season, and the splendid weather we have had during its blossom, I should expect the results to be good, unless, indeed, the long drought in summer has not also affected its honey-yielding qualities. In some cases, however, I know of hives having during the past three weeks added from this source alone from 10 to 26 lbs. to their store. The heath-blossom is early this season, and will be all over, I expect, by the end of the month (August).—J. LOWE.

FEEDING BEES AND STRENGTHENING STOCKS.

FEEDING or strengthening weak stocks by giving cards of honey from strong ones is generally delayed too long. The bee-keeper will find it a great saving of syrup or honey to feed early, as the bees will deposit far more of what they take up if fed just at the close or winding-up of the honey harvest. In all localities where there is but little fall pasturage it would be well to feed in August, or at latest by the 1st of September.

At this season most of the food given them will be deposited in the cells, and capped over the same as the honey brought in from the field, which prevents its becoming sour and unfit for winter use. And if stocks are to be strengthened, it disturbs the bees far less to do so while the weather is warm, and the bees will not consume so much of what is given them if it is given early, when they are gathering a little. Feeding or giving cards also stimulates to greater industry, and seems to encourage labour in the field, when given early, before all the flowers are gone. Let bee-keepers try it, and they will not feed late afterwards. As a rule, it does not pay to keep stocks that require much feeding; still, many stocks with a very little early feeding would become good ones, and in such instances it pays to feed.—J. H. THOMAS (in *Toronto Globe*).

OUR LETTER BOX.

DORKING COCK'S FEET SWOLLEN (E. E.).—The goodness—i.e., size of the Dorking cock, is probably the cause of his swollen feet. Forgetful of his weight, he has flown off some high place, and either bruised his feet or driven a gravel stone through the skin. In either case, as soon as the apparent callosity becomes red and inflamed, there is no cure. He may be used a little longer as a stock bird, by keeping him strictly on grass, but every step on gravel is an injury to him. This disease cannot always be prevented, but something is done in that way when the perches in a house are kept scrupulously within 2 feet of the ground, and nothing allowed in the place higher than can be used as a perch.

BRAMA COCK'S COMB (Blink Bonny).—The comb is not desirable, but we do not think it a serious fault. It would be so in a single comb.

COMB OF A LIOBT BRAHMA POOTRA COCK (R. P.).—The pea-comb is more esteemed than the single comb, and is a more valuable property if a yard is for sale. Vulture hocks, as we know from experience, show distinctly before the chickens are six weeks old. With us we condemn such at once to the kitchen, or we give them to friends to whom we owe some small obligation, and who boast that to them one fowl is as good as another. We have read of a country where all the people were hump-backed, and a stranger having entered during divine service, the clergyman prayed for the deformed man who had just entered. So a friend to whom we gave some vulture hocked birds, and who bred from them, told us he had bred some nasty plain birds from them, and could not think they were pure.

CRESTED BUFF HEN WITH JONQUE CINNAMON COCK—PAIRING LIZARDS (E. E.).—It will mainly depend upon how the Crested hen is bred. If she be from a recent cross between a Cinnamon and Crested bird not being

Cinnamon, you will probably not get all Cinnamons, but some dirty greens among them, or some broken Cinnamons—i.e., splashed birds. The greater proportion, however, will be Cinnamon, Crested and plain, Jonque and Mealy. It is perfectly right to pair a Golden Lizard cock with a Silver Lizard hen.—W. A. B.

WASPS (A Miserable Victim).—We have never found wasps do any serious injury to bees, and are, therefore, unable to prescribe a remedy from actual experience. The mouth of the hive should, of course, be at once contracted, and Mr. Taylor recommends laying a piece of barley-sugar across or just within the entrance so as greatly to narrow it. "This, he says, "is so attractive to the bees, that they muster at the door in greater force than the wasps dare venture to assail. As fast as the fortification is devoured it ought to be renewed, and the out-generalled enemy will retire from a hopeless contest." Last autumn an esteemed correspondent recommended carbolic acid as a means of repelling robber bees, and it may possibly be found to be equally efficacious in deterring wasps. His advice was as follows:—"Early in the morning, or soon as corsair bees (wasps) are on the raid, dip a feather in carbolic acid and wet the entrance of the assailed hive all round, pouring at the same time a few drops on the landing. Repeat the dose during the day as the odour passes off. If properly managed the inmates will remain at home venturing, whilst not a single robber dare cross the threshold." Fruit can only be preserved from wasps by covering it with gauze.

METEOROLOGICAL OBSERVATIONS

In the Suburbs of London for the week ending August 30th.

DATE.	BAROMETEA.		THERMOMETED.				Wind.	Rsin.
	Max.	Min.	Air.		Earth.			
			Max.	Min.	1 ft.	2 ft.		
Wed... 24	29.833	29.831	73	39	60	59	N.W.	.00
Thurs.. 25	29.866	29.833	71	42	60	59	N.W.	.00
Fri... 26	29.853	29.727	70	33	62	59	N.W.	.00
Sat... 27	29.894	29.728	73	53	64	58	N.W.	.40
Sun... 28	29.457	29.374	73	46	63	58	S.W.	.00
Mon... 29	29.891	29.733	71	48	59	58	N.W.	.00
Tues.. 30	30.197	30.046	69	32	57	56	N.W.	.00
Mean..	29.856	29.758	71.29	41.86	60.29	58.14	..	0.40

- 24.—Fine, cold wind; cloudy, but fine; clear and fine.
- 25.—Very fine; exceedingly fine; clear and fine.
- 26.—Fine and clear; cloudy, but fine; clear, starlight.
- 27.—Very fine; exceedingly fine; heavy rain.
- 28.—Drizzling rain; boisterous; heavy clouds.
- 29.—Very fine; fine but cloudy; clear and fine.
- 30.—Clear and very fine; cloudy; clear and very fine.

COVENT GARDEN MARKET.—August 31.

We have no material alteration to report, and the market continues well supplied.

FRUIT.									
	s.	d.	s.	d.		s.	d.	s.	d.
Apples.....	1	0	2	0	Mulberries.....	1	0	0	0
Apricots.....	1	0	3	0	Nectarines.....	2	0	8	0
Cherries.....	1	0	6	0	Oranges.....	1	0	10	0
Chestnuts.....	0	0	0	0	Peaches.....	2	0	10	0
Currants.....	2	0	4	0	Pears, kitchen.....	0	0	0	0
Black.....	0	0	0	0	dessert.....	0	0	0	0
Figs.....	1	0	4	0	Pine Apples.....	1	6	5	0
Filberts.....	1	0	9	0	Plums.....	1	0	3	0
Gooseberries.....	1	0	0	0	Quinces.....	0	0	0	0
Grapes, Hot-house.....	1	0	5	0	Raspberries.....	1	0	6	0
Lemons.....	1	0	16	0	Strawberries.....	1	0	0	0
Melons.....	1	0	4	0	Walnuts.....	1	0	16	0
					do.....	1	0	2	0

VEGETABLES.									
	s.	d.	s.	d.		s.	d.	s.	d.
Artichokes.....	0	0	0	0	Leeks.....	0	4	0	0
Asparagus.....	1	0	0	0	Lettuce.....	1	6	3	0
Beans, Kidney.....	4	0	0	0	Mushrooms.....	3	0	4	0
Broad.....	0	0	0	0	Mustard & Cress.....	2	0	0	0
Beef, Red.....	2	6	8	0	Onions.....	1	0	6	0
Broccoli.....	0	0	0	0	pickling.....	3	4	0	8
Brussels Sprouts.....	0	0	0	0	Parsley.....	3	0	0	0
Cabbage.....	1	0	2	0	Parsnips.....	0	8	1	6
Capsicums.....	1	0	0	0	Pens.....	0	0	0	0
Carrots.....	1	0	0	0	Potatoes.....	1	0	0	0
Califlower.....	2	0	6	0	do.....	0	0	6	0
Celery.....	1	0	2	0	Radishes . doz. bunches	0	0	0	0
Coleworts.....	3	0	6	0	Rhubarb.....	0	0	0	0
Cucumbers.....	6	0	6	0	Savoys.....	0	0	0	0
pickling.....	2	0	4	0	Sea-kale.....	0	0	0	0
Endive.....	2	0	0	0	Shallots.....	1	0	6	0
Fennel.....	0	0	0	0	Spinach.....	3	0	0	0
Garlic.....	0	0	0	0	Tomatoes.....	1	0	1	0
Herbs.....	0	0	0	0	Turnips.....	0	6	0	0
Horseradish.....	3	0	5	0	Vegetable Marrows.....	2	0	3	0

POULTRY MARKET.—August 31.

The trade is positively nominal, fortunately the supply is not large. None but low prices can be looked for for some time. Game is plentiful and good.

	s.	d.	s.	d.		s.	d.	s.	d.
Large Fowls.....	2	6	0	0	Grouse (young).....	2	0	2	6
Smaller ditto.....	2	0	2	6	Pigeons.....	0	8	0	9
Chickens.....	1	6	1	9	Rabbits.....	1	4	1	5
Ducks.....	2	0	2	6	Wild ditto.....	0	8	0	9
Geese.....	6	0	6	6	Hares.....	0	0	0	0
Turkeys.....	0	0	0	0	Partridges.....	0	0	0	0

WEEKLY CALENDAR.

Day of Month		Day of Week		SEPTEMBER 8—14, 1870.			Average Temperature near London.			Rain in last 48 years.	Sun Rises.		Sun Sets.		Moon Rises.		Moon Sets.		Moon's Age.	Clock after Sun.		Day of Year.
				Day.	Night.	Mean.	Days.	m.	h.	m.	h.	m.	h.	m.	h.	Days.	m.	s.	m.	s.		
8	TH	Crystal Palace Florists' Flower Show closes.			69.4	48.0	58.7	19	25	af 5	29	af 6	29	af 6	13	af 3	19	2	54	2	54	251
9	F				69.1	48.1	58.6	19	24	5	27	6	51	6	24	4	19	3	45	3	45	252
10	S	Length of Day 12h. 58m.			69.7	45.5	57.6	21	27	5	25	6	11	7	55	5	15	3	5	3	5	253
11	SUN	13 SUNDAY AFTER TRINITY.			68.7	47.0	57.8	11	29	5	22	6	28	7	44	6	16	3	26	3	26	254
12	M				69.1	44.8	57.0	16	31	5	20	6	46	7	52	6	17	3	47	3	47	255
13	TU				68.4	45.7	57.0	19	32	5	18	6	5	8	57	8	18	4	8	4	8	256
14	W	Nottingham Horticultural Show.			67.0	46.1	56.5	22	33	5	16	6	24	8	3	19	19	4	29	4	29	257

From observations taken near London during the last forty-three years, the average day temperature of the week is 68° 2/3, and its night temperature 46 1/4. The greatest heat was 88°, on the 13th, 1855; and the lowest cold 28°, on the 12th, 1860. The greatest fall of rain was 1.27 inch.

RAMBLES ABOUT CORBRIDGE. SANDHOE.



I WAS spending the vacation at Corbridge, an old village on the Tyne, in the centre of the garden of Northumberland—an old village, nobody knows how old, with an old church, a grand old church, and an old stone bridge, very long, very narrow, and abominably dusty, with always the same old man on it with an old barrow and shovel, engaged in the manure line of business. It was a hot day—I cannot say what the glass was standing at in the shade, but the cows were all standing up to their knees in the river, illustrating the theory of perpetual motion with their tails. I sauntered down to the river-side to a small piece of what I thought was unenclosed waste ground. It looked like it, though there was an old broken rail fence on one side. I think Corbridge shoots its rubbish there when it has any to shoot. The old fence, a very shabby old fence, ran down almost to the water's edge, or what would be the water's edge when the rains swelled the river, which now, with its gravelly bed laid bare through the long drought, was lazily creeping on towards the bridge, on which I could just see the old man's head bobbing up and down above the parapet: he was evidently reaping a rich harvest of ammoniacal deposits that morning. The other side of the fence looking rather more inviting, but not much, I stepped over the rail and sat down. I cannot say I was comfortable. There was not much grass, and my seat was hard: besides, I was pestered by the flies, impertinent, inquisitive flies, with a thirst for a knowledge, geographical and anatomical, of my epidermis. It was not by any means a pleasant spot, but such as it was I was not allowed to occupy it long. A lad, who seemed half afraid or half ashamed (let us hope he was: he was a decent-looking lad) to deliver his message, came to me with an intimation that I was to "go away, go away; it's private property, private property," and then he retreated; and so did I in the face of a "notice," which I had not observed before, to the effect that if I were found trespassing on that ground, or drying my clothes on its fences, I should be prosecuted with the utmost rigour of the law. The launch of a paper ship with a dandelion mast, which I was under contract to complete for "Jacky," was deferred to a more convenient season: for which demurrage he suggested that the sum of 4*l.* would be an acceptable equivalent, to be invested in a donkey-ride. The donkey tariff in Corbridge is, with or without a saddle (which is always a side saddle, difficult to put on, and apt to slip round, but very handy to hold on by), 4*l.* an hour; ditto with cart without springs, but plenty of straw, 6*l.*

But what has this to do with Sandhoe? A good deal. The donkey took us to Sandhoe. I went rather against my inclination; I am certain he went contrary to his, though he was on the whole a well-behaved ass, not given to rubbing against walls or rolling in dusty roads. I would rather have been off among the grand old woods about Dilston than on terraced walks or among flower beds and

ribbon borders. I wanted rather to get away from Nature "with her hair cut," than to travel over hot dusty roads under a broiling July sun to see a specimen however beautiful. I was anxious to get away from the "noise and smoke of the clearings," as my eldest boy, who is great in Indian story, has it. He carries colours and chalks (war-paint he calls them) in his pocket, and when we were in the woods was continually waylaying poor Jacky, and scalping him. Once he tried to make me a party to a horrible plot, proposing that I should let him touch me up with a bit of vermilion and a flannel blue-bag, and then rush in and carry his mamma into captivity, when he would give me five minutes' start and follow my trail, and when he had rescued her, would tie me to a tree, and show me how near he could come with his knife without hitting me.

I shall never reach Sandhoe at this rate, which is just what I thought toiling up the hillside that hot July day. Once there, my only regret was that I had deferred my visit so long, and that I had not more time at disposal to examine all the beauties of the place. Sandhoe, the seat of Sir Rowland Stanley Errington, Bart., is most delightfully placed on the hillside on the left or north bank of the Tyne, about midway between Hexham and Corbridge, adjoining the lordly manor of Beaufront. The principal entrance to the grounds is through a beautiful gateway surmounted by a massive stone arch, but I entered this little paradise through a private door opening on a winding path, hedged in with Laurels of most luxuriant growth, leading to what I may call Terrace No. 1, the arrangement of the grounds being a system of terraces, a plan necessitated by the nature of the site, and worked out in detail by the head gardener, Mr. Marshall, with infinite skill.

The first terrace was a Rose walk, which my attendant, an intelligent young Scotchman, informed me is 200 yards long, and I can only describe it as one continuous bower of Roses carpeted with velvet pile. The most striking feature in it is a series of festoons formed by connecting the uprights of some rustic work on either side with light chains both longitudinally and transversely, the whole being clothed with masses of lovely Roses. The *coup d'œil* is charming.

An easy descent from this fairy palace leads to a beautiful sloping lawn stretching away in a bold circular sweep from the west-end of the house, which faces terrace No. 2, the terrace. The higher part of the lawn is scalloped its entire length with flower beds of elegant design, something like a series of inverted *fleur-de-lis*. Looking at them as they lie on the slope with the apex towards you, the outer row of plants next the grass, forming an edging to the bed, is *Cerastium something-osum*, then blue *Lobelia* and Golden *Pyrethrum* mixed, with the centre, or body of the bed, *Calceolarias* and scarlet *Geraniums* in each alternate scallop, while at the base of each stands either an Ivy-covered vase or an Irish Yew. I have never seen Ivy turned to such purposes as it is at Sandhoe. Some of the long slopes are of Ivy, and very effective they are. The west-end of the lawn is bounded by the woods of Beaufront, consisting of fine specimens of Larch, Oak, Beech, and Lime, with ornamental Pines and other Conifers on the

margin. The grass itself was in excellent trim, and I was informed they used Green's machine. I asked if they had seen the Archimedean, and produced the picture which gives Jacky so much anxiety as to how the man has broken the handle, but I fancied my attendant had some idea I was an agent fishing for an order, and was, therefore, not very communicative on the subject of grass.

The house faces terrace No. 2, and is in itself an object of great attraction to visitors, from the costly character of the internal decorations. In the front are several flower beds, in some of which Mrs. Pollock Geranium was growing in great perfection, the masses of richly-variegated foliage showing to great effect. The centre of the terrace, which is 254 yards long, and is being extended to about 600 yards, is occupied by a lawn with a ribbon border on each side; that to the south, or remote side, being edged with Flower of the Day Geranium, with rows of Calceolarias and scarlet Geraniums, intermixed with a pretty ornamental Grass, and bounded by a Yew hedge—a low, living, green wall, alone worth going to see. At either end of the lawn is an oval-shaped raised bed of four steps, the first consisting of a front of Ivy, carpeted with Calceolarias and Flower of the Day Geranium; then more Ivy, and a floor of scarlets; next Ivy, and a surface of white; then Ivy again, crowned with dwarf white Dahlias. But the most pleasing feature on this beautiful terrace was the fragrance emitted from an inscription on a tablet built into an Ivy-covered wall supporting one of the upper slopes.

"Stranger, within these grounds,
Whoe'er thou art,
No limitation of thy freedom fear;
Go where thou wilt,
And when thou wilt depart,
Since for thy pleasure all is ordered here.
"R. S. E."

It is needless to say whose initials are these, nor is it a matter of surprise to find the writer's name uttered by the poor with blessings, as well it may be, connected as it is with unostentatious acts of practical Christian charity. I will just stay to remark that this little Eden is open from morning till night to all who choose to lift the latch of any of its gates. No fear of being told it is not convenient, or that the "family" are at home, or of being warned off and told to "go away, go away; it's private property, private property!" If the "family" meet you, it will raise its hat if you be a lady, or bid you a hearty good-day and welcome if you be a gentleman; and then, if you be a true gentlewoman or gentleman, you will neither lean over the Yew hedge or press it out of shape, nor splash about in the fish pond. I saw both done, and should have thought it no sin to pitch one offender over the hedge, and baptise the other.

The slope from this terrace to the next is clothed with Ivy kept close to the ground, and a more effective foliage cannot be conceived. Along it runs what may either be called a Lime avenue or another Rose bow. The Lime trees are trained to very prettily-designed rusticwork, and are already assuming the characteristic form of the trelliswork, which will ultimately be removed. They form a beautiful leafy canopy overhead. The spaces between the trees are occupied with Roses, while here and there a straggling piece of Ivy from the slope has been allowed to add its share to the beauty of this shady retreat. At the east end is a roomy summer-house, oval-shaped, with a roof of bark thatched with heather, containing rustic tables, chairs, and lounges. More slopes, more Ivy, more flowers, and we are on the lowest terrace, in the centre of which are a large circular basin and fountain. The Yew hedge, which forms the extreme south boundary of this walk, is 3 feet high, and of the same width, clipped exactly square with astonishing accuracy.

The view from this point is very fine. The Tyne is seen running eastward for some distance. To the west, at a short distance, lies the quaint little town of Hexham, the tower of the Abbey church standing out grandly above the surrounding buildings, which seem snugly nestled in among the trees at the foot of the hills, a little cloud of bluish smoke floating over, marking its site and apparent area. Almost in front, on the further side of the river, surrounded by its majestic woods, is seen the solitary tower of Dilston Castle, a grim memorial of the bygone glories of the Derwentwater family, while stretching far beyond to the south lie the hills enclosing the valley of the Tyne. To the west is Corbridge with its church, not so pretentious, perhaps, as the more majestic pile at Hexham, but replete with interest. We pass close under its shadow as we return home. Just one word about this hoary old temple before

I say good-bye to a day whose pleasures I shall long remember. Seeing the doors open one morning, and hearing the voices of the choristers, I entered, and found that it was the celebration of Divine service on the occasion of one of the festivals of the Church. Perhaps I was impelled by curiosity, for I had heard of the ritualistic services of Corbridge. What a blind thing is prejudice! I had been led by hearsay to expect to see nothing less than a cloven hoof peeping from beneath the caesock, but I could perceive nothing but the cross elevated with a majestic simplicity. The congregation was not large, as might easily be expected in a country village on a week day, but the service was most impressively rendered by the vicar, the Rev. Mr. Gipps, M.A. He kindly spent fully an hour, nay more, after service was over in pointing out to me every object of interest in the building, which has been only lately restored under his own immediate superintendence. A more enthusiastic ecclesiastical antiquarian it has never been my pleasure to meet; and bringing to bear on the subject a scholarly mind, he invested every stone in the old church with a history of its own, converting old grey, time-eaten blocks by a touch of his magician's wand into living testimonies of that undying faith which our forefathers handed down to us. It was plainly to be seen, too, how the desolating effects of war had visited the sacred building. Here in one corner of the noble tower are unmistakable evidences of the troopers in the border warfare, or in the bloody wars of the Roses, having bivouacked under its shelter, and in another are the marks where they sharpened their pikes upon its corner stones, while the effects of fire are observable everywhere. I said it was an old church, a very old church, nobody knows how old, and so it is.—W. A. BLAKSTON.

BEDDING PLANTS IN 1870.

(Continued from page 148.)

In continuing my remarks on bedding Geraniums, I come next to the reds, as Mrs. Laing, King of the Nosegays, and Rebecca.

Mrs. Laing is very dwarf and free-flowering, and is a very useful sort, as it seems to stand weather well; the colour is rather dull. King of the Nosegays has a very fine truss, and is of good habit; it is a bright shade of red, and deserves a trial everywhere.

Rebecca, though free-flowering, has run to seed with me very much this year, and I have heard the same complaint from others. It is one of the very best, however, for pot culture for winter blooming.

I will next take the cerise-coloured, as Violet Hill, Duchess, Amy Hogg, Dr. Hogg, Arthur Pearson, &c.

Violet Hill is still my type of the best bedding Geranium I have ever seen. It only requires good treatment to remain in full beauty all the summer months. It is very compact and dwarf, branches naturally, and is one of the freest bloomers both as a bedder and a pot plant I have ever seen. It is not much in nurserymen's hands, because it requires time to propagate a stock of it, and in some gardens it has been discarded because it has not grown enough, but it will well repay any extra care in saving all old plants, and liberally manuring the beds before planting; for however freely it may be made to grow, it will always blossom as freely.

Duchess is a good sort for a back row, and it did well this dry summer in Gloucestershire, but it is too coarse most seasons. It is another good sort for winter blooming.

Amy Hogg is too well known to require much comment. I still think it too long in the footstalk. Arthur Pearson is very like Amy Hogg, with rather a rounder flower, and stronger footstalk.

Dr. Hogg is a decided improvement on Amy Hogg—a very bright telling colour without being gaudy, and a free bloomer. It is rather apt to run to seed, but this has been too much the case with most Geraniums this year. It makes a beautiful pot plant, and is one of the freest bloomers of any in the winter. It is altogether a very valuable variety.

Comte de Morny is one of the best Zonals, as it has naturally a branching habit; its colour is more pink than Amy Hogg, and it is decidedly the best bedder I know in that colour.

Roi d'Italie and Glorious are much about the same shade of colour, cerise with an orange shade. Roi d'Italie has fine individual flowers but small trusses, and does not stand weather well. Glorious has done well this year.

Indian Yellow has a very peculiar shade of colour, is one of the freest-blooming Geraniums of any, and is always worth

growing as a contrast to other colours. It stands sun and rain better than almost any variety I know.

I have only tried two orange-coloured Geraniums this year—viz., Orange Nosegay and Grace Holmes. The latter is, in my opinion, a great acquisition, very dwarf and free-blooming, and will, like Violet Hill, stand good treatment, when it will flower freely without growing coarse. Orange Nosegay is of a good colour, but too small in the truss, and does not bloom freely enough.

We next come to the pink and rose section.

Of these Rose Rendatler is *facile princeps* with me, and has proved itself the best for four years. On some soils it is coarse; here both old plants and young bloom freely, and stand the weather well. Its fault, which it has in common with all pinks, is its tendency to run to seed.

Ne Plus Ultra is a very fine shade of pink with a good truss of flowers. I do not think, however, it blooms freely enough.

Blue Bell is too coarse with me, but it is a different shade of colour—a lilac pink—has a handsome truss of bloom, and I shall certainly try it again, as I think for the sake of variety, and to prevent monotony, one cannot have too many different shades of colour.

Pink Perfection is a fairly good sort. Pink Stella does not bloom enough, and after three years' trial I shall discard it.

Comtesse de Rosslyn, which I had not enough of for a separate bed, and which I planted in a mixed bed, is a promising sort, with a dwarf habit, but more lilac than rose.

Christine Nosegay has also a nice dwarf habit with a soft light shade of pink, but hardly blooms freely enough, and is too stiff in the growth.

Gloire de Corbenay was the only salmon-coloured Geranium I hedded this year, and it has done better than any salmon I ever tried before, having had to discard Eugénie Mezard, François Desbois, Madame Kundersdorff, and others. I shall certainly try it again, and I think it will succeed.

All the whites I have ever tried have turned to a dirty pink in the sun, but they have all been so like their prototype, Madame Vaucher, as for all practical purposes to be identical; but one which was sent me on trial by Mr. C. Turner has kept its colour well, is of quite a different habit, and seems to me most promising, and I intend to give it a good trial next year. Another good dwarf white which has kept its colour was kindly sent me as a present by Mr. Aldred, and will, I think, bed well.

I will defer my notes on the Bicolors, Tricolors, and Variegated sorts till another time. I would only conclude now by saying, if I had to choose twelve (not counting newer sorts), one of each colour, I should take the following:—Waltham Seedling, Bayard, Cybister, Grand Duke, Violet Hill, Duchess of Sutherland, Dr. Hogg, Indian Yellow, Grace Holmes, Gloire de Corbenay, Rose Rendatler, and The Bride. I have included the latter though a new one, as I do not know any white of the Madame Vaucher type worth growing. I can also unhesitatingly recommend Vesta, Lady C. Grosvenor, Douglas Pearson, Thomas Speed, William Thomson, Lady Hawley, Lady Kirkland, and Stanstead Rival.

Since writing the above notes we have had heavy rain, 0.92 inch in one night, and the sorts which have stood it best are Waltham Seedling, Bayard, Violet Hill, and Indian Yellow.—C. P. PEACH.

BUSH VINES IN POTS.

MR. PEARSON'S account of the pot Vines at Chatsworth has much interested me; perhaps some of your readers may like to know what may be done with pot Vines grown as bushes about 5 feet high, including the pot. I have ten pot Vines fruiting in 13-inch pots on a raised border in a cold vinery, the roof being covered with border Vines; they are two years old, and no fruit was taken from them last year, which may account for their fruitfulness this year.

In November last they were pruned according to Mr. Rivers's directions. The earth 4 inches down the pots was taken out, all roots springing from the stem cut off to an inch in length, and the vacant space filled with fresh earth (clayey loam), and plenty of half-inch bones, well rammed down. Nothing was done in the way of painting the stems. The pots were then laid on their sides on a south-east border, a little earth was thrown up round them, and the Vines bore 13° of frost without injury. In the middle of February they were set in their places; all buds were allowed to break, and stopped at one joint beyond the bunch of bloom. As soon as the berries were set they had a plentiful top dressing of malt screenings and

horse droppings in equal quantities, a second edition of the same when the berries began the second swelling, plentiful supplies of tepid water throughout, and liquid manure of sheep droppings, *à la* Pearson, twice a-week until colour appeared. A good crop has been the reward of the trouble which the watering and general treatment entail. Two Black Hamburgs have five bunches each, Black Frontignan three, Sweet-water nine, Black Bordeaux ten, Frankenthal four, Muscat of Alexandria seven, Muscat St. Laurent six, Royal Muscadine seven, and a Black Hamburg, grown through a 6-inch pot, bears six bunches. The last-named Vine has now two sets of roots, the lower in a 13-inch pot, the upper in a 6-inch pot, and when the Grapes are ripe, by dividing the stem between the two pots I hope to have a handsome ornament for the sideboard.

I may add, that the Muscat St. Laurent, which Mr. Pearson describes, or abuses, as a "worthless little early Grape, with an objectionable Muscat flavour," has with me large bunches and fine oval berries of a yellowish-green colour. I have not cut any, so can say nothing about the flavour, but it is worth something to look at.—V. W. PORHAM, *Portreath, Cornwall*.

BEEF FOR A FLOWER GARDEN.

At page 113 I saw an article on Beet for decorative purposes, and I fully agree with your correspondent that Beet is certainly out of place anywhere but in the kitchen garden. This year I purchased seed of a well-known firm, and when ready I planted out in the flower border in places where I should otherwise have put Colens had I not heard the Beet so highly spoken of. I have been thoroughly disappointed with the result of my experiment for, instead of separating the lines of colour as I had intended, the Beet has simply overgrown everything, notwithstanding the bushels of leaves that have been cut off. Some of the leaves are now 30 inches high instead of about 12 inches, the height those in my kitchen garden usually attain. Now I want cuttings of Tom Thumb Geraniums and Calceolarias, which plants the Beet divides, but positively have none. My only apparent resource is to cut down the wretched Beet (which I intend doing next week), that my legitimate bedding plants may grow more freely.—H. GAINSFORD GUTTO.

NOTES ON POTATOES, CUCUMBERS, AND ROSES.

I MENTIONED in my last that I had here (Somerset), planted several varieties of Potatoes in rows on the same piece of ground, using to each row 1 lb. of seed cut in sets. The following were the kinds—Early Rose, Climax, Bresee's Prolific, Bresee's King of the Earlies, Carter's Queen of Potatoes, Carter's Ashtop Fluke, Rivers's Royal, Sutton's Racehorse, and Kelway's Nonpareil. Rivers's Royal, Climax, Nonpareil, and Early Rose were up a little before the rest. They all met with that severe frost which was so general, and I looked out one morning to find them all as black as a coal. I thought to myself, Here is an end to my trial and my prize seed; but they came round, and I give the result. The first I dug was Climax, and well pleased was I to find that my 1 lb. had produced 17 lbs. of fine, large, good-looking tubers. I must add that at least one-third of the sets of this variety were quite killed by the frost; it seems to be the most delicate of all. Of Bresee's Prolific I had 29 lbs.; King of the Earlies, 25 lbs.; Kelway's Nonpareil, 27 lbs.; Carter's Queen of Potatoes, 10 lbs.; Ashtop Fluke, 9 lbs.; Rivers's Royal, 11 lbs.; and Sutton's Racehorse, 7 lbs.; but when I came to Early Rose I could scarcely believe my eyes when I found that I had 52 lbs. of enormous tubers with scarcely a small one amongst them. I was prepared to receive the Yankee character of this Potato with one or two large "grains of salt," but the result has surprised me beyond measure. In my whole stock of twenty-four varieties I give the palm, taking all qualities into consideration, to Early Rose and Nonpareil.

My Roses this year, as a whole, have been good. I have had splendid blooms on Alfred Colomb, Xavier Olibo, Baroness de Rothschild, Princess Mary of Cambridge, Marguerite de St. Amand, La France, Christine Nilsson, and Pierre Notting. Duke of Edinburgh, Edward Morren, Clémence Raoux, and Lord Macaulay, with some of the other dark Perpetuals, have been so infested with mildew that as yet my blooms have been indifferent. I have grown very fond of Archimède, Monsieur Fortado, Meiret, and Fortune's New Yellow, among Teas. I

shall expect to show some good examples of them this autumn.

I have this year had a beautiful show with Arab and Egyptian Queen, among Golden Geraniums. I much prefer the Bicolors to the Tricolors, for a show *en masse*; they seem to me to make a far brighter bed.

I have tried a great many different Cucumbers during the last year. Two plants of Carter's Champion were placed in my frame, heated with hot-water pipes, the last week in October, and I cut fruit from them up to May, when I wanted my frame for Melon plants, so cleared them out. I had the pleasure of giving away seven Cucumbers for Christmas-day, and during the whole winter I never was in want of that useful fruit.—STIFF SOIL.

P.S.—I should have said that I tried Paterson's Bovinia, with the rest of the Potatoes; I had literally nothing but haulm for my pains.

NOTES ON STRAWBERRIES.

"Doctor Hogg (Bradley).—Very large, handsome, rich, a great bearer, and of very healthy growth. Perfection." Having grown this Strawberry for the last three years, I can endorse the above description as given in the catalogue of Mrs. Nicholson, of Yarm, for 1868—69.

The soil of this garden is not one favourable to the Strawberry, being of a light character, of no great depth, and resting upon what we in Derbyshire call a "ratchely" bottom—that is, a substratum of loose stones, and inert, hungry sandy matter, which probably in its turn rests upon the rock, as a solid floor of gritstone rock crops out some 50 yards from the south-western corner of the kitchen garden wall, and at no great depth from its level. I found some years ago that that type of a good Strawberry, the British Queen, would neither grow nor bear satisfactorily here, and consequently the variety ceased to be grown, along with some others which at different times have shared the same fate, such as Old Pine, Fibert Pine, Oscar, Carolina Superba, Crimson Queen, Rivers's Eliza, Kimberley, &c. Out of a somewhat large number of varieties, I three years ago reduced my principal stock to three—viz., Dr. Hogg, La Constante, and Sir Joseph Paxton, with smaller quantities of Sir Harry, an excellent Strawberry, Elton Pine for late crop, and Black Prince, which is still a useful early kind. I have for trial next year, and awaiting the trenching of a piece of ground for their reception, runners of Lucas, Vicomtesse Héricart de Thury, Mr. Radcliffe, President, Cockscob, and John Powell nicely established in small pots. I am afraid I shall not greatly improve on my three favourites as given above, or notably on the first-named and subject of my text, Dr. Hogg, though I suppose that it has in Mr. Radcliffe a formidable rival for honours in this class. I must say, however, as an honest chronicler of facts, that Sir Joseph Paxton (for the first time with me) has this season been affected with mildew to a serious extent. I am afraid there must be some hereditary predisposition to that disease on the part of Sir Joseph Paxton, as I see Mr. Douglas reports the same at page 140. I see at page 121 that John Powell is placed in the *index expurgatorius*.

I find that in this soil it is very undesirable practice to fruit the same plants more than three years, but by securing runners early, and layering them in pots, I obtain well-established plants that produce a fair quota of fruit the first year of fruiting; the second year the fruit will be both fine and abundant; and probably the third year there may be an abundant crop, but the fruit will be very sensibly less in size. I am not certain but that, if ground and time were plentiful, it would not be better to take but two crops off the same plants. On soils more congenial to the plant, the necessity for a constant migration of the Strawberry quarter may be less. To all cultivators of light-land gardens I would say, in the present state of my experience with reference to the different varieties of Strawberries, commend me to Dr. Hogg.—W. HUDSON, *Chase Cliffe, Derby*.

THE COMMON BERBERRY.

In most shrubberies which have been established for any length of time will be found a plant of this in the background, cut and hacked as if its presence there were only tolerated as a nuisance, yet the wild Berberry, when grown to perfection, is one of the most handsome of our deciduous shrubs, especially when covered with ripe fruit. Some years ago I was forcibly struck with this on visiting Drumlanrig Castle, the princely

seat of the Duke of Buccleuch, in Dumfriesshire, where single specimens of this shrub were dotted about amongst Spruce Firs and other Conifers on the more distant parts of the lawn. Instead of the miserable, one-sided, half-cut-away objects we often meet with in a mixed shrubbery, there were single specimens of conical shape loaded with the ripening fruit, and looking, when seen from a distance, like so many huge Fuchsia bushes, differing widely from the miserable objects we often see struggling for an existence amongst plants of more robust growth. Despite the cutting it experienced on account of its medical virtues, it still struggled on, but at Drumlanrig it was all in its glory. Whether the rainy climate, or the soil partaking of the Scottish Highland character, was more favourable to it than other lowland parts I cannot say, but certainly the plants which I saw there in the early part of September were models of beauty, and I believe had received very little, if any, pruning. The handsome fruit of the wild Berberry certainly entitles it to more attention than *Berberis dulcis* and some similar species; for although these flower pretty well, they bear but little fruit, and very often none at all; while the wild Berberry is as prolific as a Currant or any other fruit.—J. ROBSON.

GROWING ZONAL GERANIUMS FOR EXHIBITION.

YEARS ago, when one saw in a schedule of prizes a class for three, or four, or six "Scarlet Geraniums," the intending exhibitor had no difficulty in understanding what was required, for at that time the number of varieties was limited to those having more or less of this shade of colour in the flowers. Then, when with an increase of varieties came some having flowers with quite pale colours, the limitation of "Scarlet Geraniums," though always widely interpreted as inclusive of a certain class rather than of a certain shade of colour, was felt to be somewhat absurd; and in time that gave place to "Zonal Pelargoniums," the former again widely interpreted as taking in all that section known as "Scarlet Geraniums," though having flowers of various hues and leaves destitute of the zone common to many of them. A better botanical knowledge also led to the substitution of the generic term *Pelargonium* for *Geranium*. A wonderful improvement has gone on in these plants during the past twenty years; and tracing forwards from the circle of bright colour in the flowers of the well-known Tom Thumb, it has been seen to change, like a chromatope, into a wondrous variety of shades of colour and types of flowers, that now form at summer and autumn exhibitions some of their brightest and most effective features. The general term "scarlet," still found in some schedules of prizes, has become a misnomer. We are no longer confined to that sole colour, but have a range from the purest white, as found in Purity, to the deep crimson scarlet of Sambo. Thus it is easy and possible to stage, in a collection of six, nine, or twelve plants, as many shades of colour; and there is not a good variety in cultivation at the present day of which a well-grown plant does not constitute a striking and beautiful object. But classes and varieties have developed as well as colours; and the Zonal *Pelargonium*, swelling into importance with its high-sounding name, has assumed double forms that bid fair to become formidable rivals to the single varieties, either for exhibition or for decorative purposes. It is true the range of colour in the flowers is as yet somewhat restricted; but that is a drawback that probably will not long exist, whilst it is also largely compensated for by the more permanent character of the flowers, which retain their petals and consequent usefulness for a much longer period. The Nosegay section has usually a separate class also allotted to it, because it differs in its general features somewhat distinctly from the original Zonal kinds; but later varieties have exhibited such an approximation in the form of the pip to that of the best of the Zonal section, whilst retaining all the Nosegay freedom of growth and floriferous character of truss, that we may naturally look by-and-by to such a fusion of the two divisions as shall result in one improved type that will swallow up the distinction, but leave us, nevertheless, a section perfect in beauty and in form, and possessing all those features that make the Nosegays so popular both for bedding and pot-culture.

Perhaps it will not be out of place to state at the outset that there is no exhibition plant that appears more to dislike training, or less to require a formal severity of shape, than the *Pelargonium*; and yet, in spite of these facts, there are to be

found plenty of judges ready and willing to make leading awards to plants that have been subjected to a degree of training and torture that would be ridiculous were it not that it is almost disgusting in appearance. Who that has visited metropolitan shows is not familiar with those flattened surfaces bearing a resemblance to giant floral Mushrooms? or, if you like, flower beds upon wire? What a miserable parody on plants do these things present, tortured and twisted out of natural form, devoid of all grace and beauty! They add another instance of the fitness of the saying, "that Nature gave us form and outline, and humanity alone are its despoilers."

As a reverse to this, I have lately seen staged for competition at a provincial show a lot of pillar-trained plants, from 4 to 6 feet in height, certainly fairly flowered, but, nevertheless, looking so ungainly as to merit ridicule rather than praise. Unfortunately against them there was no competition, otherwise I should have viewed with some interest the awards of the judges, as, in spite of size and flower, I could not conceive that any sensible men would have placed these statuesque abortions before well and naturally-grown specimens. As a mode of training to obtain plenty of bloom the pillar plant may be very useful, but for exhibition it only deserves disqualification.

My specimens have usually been prepared for autumn exhibition—say in the beginning of September; and having this in view, I get some cuttings and put them, in early in the previous year, and when well rooted, potted-up into 48's to stand the winter, giving the shoots their first stopping. In an ordinary greenhouse these plants will not make much growth during the winter, but by the beginning of April will be ready for a shift into 32's, giving any robust shoots another pinching. Plenty of air and light are necessary now to maintain robust short-jointed growth, and by the time the pots are well filled with roots the cold weather will have passed away, and the external air may be safely trusted. To save much needless labour, a shift should now be made into the blooming-pots (No. 12 is a good size for that purpose); and as the plants are to remain in these for a long time, a really good compost should be used, nothing being better than yellow loam, well-rotted manure, especially cow dung, and a fair mixture of sand. I find it desirable to pot firmly, otherwise the soil will settle very much by the autumn, and, therefore, it is better to make it all the firmer at the first. When the plants are thus potted, and especially potted low down, an open situation in the garden is selected that is convenient for watering. A good, hard, and level bottom should be secured, or, if soft beneath, pieces of slate should be used to place the pots upon, to exclude the worms. Here the plants should be placed at proper distances from each other to admit of growth without crowding, and then filled-in all round to the brim of the pots with ashes or some other good plunging material, so that the roots are thus protected from the force of the sun's rays, and consequent drought and exhaustion. The bedding Pelargonium can bear almost any amount of solar heat with impunity if its roots are kept moist and cool. As I usually put my plants in the open air at the end of May, and get them under glass from a week to ten days only before showing, they thus get about three months of thorough exposure to the weather, and are as dwarf and short-jointed as could possibly be wished. Of course, the process of stopping has not been neglected, but rather has been maintained with constant regularity, every strong shoot having its extremity nipped out as fast as it had made three or four joints, care being taken also to encourage the centre growth, so as to secure a somewhat rounded form. An occasional turning round of the plants will also facilitate the production of a good shape. Pinching out all points and flower-buds is rigidly continued until within one month of the time of showing, when the process is discontinued, and the plants are allowed to grow away as freely as they please.

As a result of all this careful attention and exposure, the grower will find that he has a lot of robust, dwarf, bushy plants, that will now commence to throw up a mass of flower well above the foliage, that will, when expanded, need but the finish of a week or so under glass to make them perfect specimens. There are no yellow or discoloured leaves to be seen, all is fresh and vigorous; and the plants, after they have brought the highest honours at the show, will, with a little attention, make a greenhouse or conservatory look very gay indeed nearly up to Christmas.

The Zonal Pelargonium is naturally a gross feeder, and will take up an abundance of strong diet. The use of such material, however, to plants in the open ground would have a

most undesirable tendency. This objection does not exist in the case of pot plants, as the roots, being confined within a contracted space, are necessarily subject to different conditions, and need stimulants to maintain that free growth so essential to the production of good specimens. Any application of liquid manure is scarcely needed until the flowering pots have become filled with a mass of roots; but when such is the case—and that would probably result in about six weeks from potting—then a watering of a weak mixture twice a-week is desirable; and this dose may be increased in strength when the bloom is allowed to come up, as the claim on the resources of the plants will be proportionately increased. Horse droppings well soaked in water usually make good liquid manure, and even stronger stuff than that may be used, such as guano water, drainings from cow sheds, and even from the closet cesspool, as I have used this latter during the past summer in the proportion of one bucketful to about five of water with the best results. Amateur growers, especially, may take my word for it that they will secure better specimen plants in moderate-sized pots with a free use of liquid manure than they can obtain in large pots under any conditions, besides the credit of having produced as good or even better results in small pots than their fellow-competitors have realised in large ones.

Readers will have observed that I have not proposed the tying down or pegging of the plants in any way, and I say certainly not, as all these processes are to me highly objectionable. I strongly contend that it should be the object and purpose of all exhibitors to produce specimen plants that have been as little as possible subjected to training with ties or sticks in any shape or fashion. Especially does this apply to the Zonal Pelargonium, as training of any description other than that induced by stopping is both unnecessary and absurd. I have now ready for show a fine lot of dwarf compact plants, with close rounded heads, each about 2½ inches in diameter, and which will be larger still in a few weeks hence. Flower stems are being thrown up all over them, and I have every reason to be satisfied with the prospect.

The treatment that is here so strongly recommended for the Zonal section bears with equal force to the growth of the Nosegays, with the exception that some of the latter require less pinching, otherwise I make no distinction as to treatment. The double Pelargoniums are now rapidly becoming popular, and have become at many shows a class of themselves; and exceedingly attractive they are when well-grown specimens. With these pinching must be performed with rather more moderation, but should still be carefully attended to, otherwise the plants will soon become leggy. If well looked after and grown as herein described, plants as dwarf and compact, and almost as free of flower as the single varieties, can easily be produced.

I shall conclude with a list of twelve good show Zonals, the same number of Nosegays, and six double-flowering Pelargoniums, all of which will well repay good cultivation.

ZONALS.		
Purity. Clipper. Rosabella. Excellent.	Sambo. William Underwood. Beaute de Suresnes. Lord Derby.	Highgate Rival. Madame Madeline. Dr. Lindley. Madame Werle.
NOSEGAYS.		
Grand Duke. Violet Hill Nosegay. Chilwell Beauty. Gathorne Hardy.	Celestial. International. Eclat. Euneline.	Dr. Hogg. Triomphe de Stella. Pink Globe. Mrs. Laing.
DOUBLE-FLOWERING		
Wilhelm Pützer. Gloire de Nancy.	Andrew Henderson. Victor Lemoine.	Madame Lemoine. Marie Lemoine.

—EXHIBITOR (in *The Gardener*).

OSBORNS' SELECT RED BEET, ALIAS DELL'S BEET.

Your number of August 25th contains an article on the so-called Dell's Beet, justly praising it for its decorative qualities, and expressing some doubts as to its retaining for any length of time the same character. Now on this point we can speak from experience. Nearly twenty years ago we had this same Beet from Mr. Bogue, the intelligent gardener at Gorbambury, near St. Albans (under whom Mr. Dell once acted as foreman), and distributed it under the simple name of "Fine Dwarf Red Beet," until the year 1866, when it became spoken of as a very useful decorative plant, and to prevent confusion, with Mr. Bogue's consent, we affixed our name to it, and have con-

tinued to grow it extensively for seed at our Sunbury nursery, where a large quarter may now be seen as true to character as when it was first sent out, and admired by everyone who sees it, for its decorative effect.—OSBORN & SONS, Fulham Nursery, S.W.

METROPOLITAN FLORAL SOCIETY'S FIRST SHOW.

SEPTEMBER 6TH, 7TH, AND 8TH.

AN autumn show of florists' flowers—a show which would bring together at one time the early autumn flowers from a number of exhibitors in all parts of the country, has been a long-felt want among florists. The Crystal Palace Autumn Show was given up some years ago, because it did not pay, and the subjects of exhibition at that show were mainly flowers of the description just referred to and fruit. Since then there has been a blank, which has only been to some extent filled by the Floral Committee meetings at Kensington, but it was felt that larger prizes should be offered to bring competitors from a distance and in sufficient numbers to create an autumn exhibition equal to those held at the Crystal Palace some years ago, and which would be worthy of English florists. The Rev. H. H. Donbrain conceived some time ago the happy idea of resuscitating an autumn show at the Palace, he was supported with great spirit, and the result has been a complete success, for the show, which opened on Tuesday and will close this evening, is better than most of its predecessors at the same season at the Palace, there being, as we are given to understand, fully double the number of entries. Of the quality it is impossible to speak too highly—the Dahlias with but few exceptions are equal to those produced in the best of seasons, and in some stands even better than in more favourable years. The Gladioli are excellent, Hollyhocks good, and Roses good for the time of year. The Society may therefore be congratulated on the success of this their first exhibition, and it only wants a little more encouragement, and that encouragement we are convinced will be given, to render its exhibitions permanent. Now that one part of the Autumn Show at the Palace has been renewed, would it not be desirable to make an effort to restore the other—fruit?

In the class for forty-eight Show Dahlias, Mr. Keynes, of Salisbury, is first with splendid blooms of John Kirby, Queen of Beauties, Vice-President, Annie Neville, Gazelle, Lightning, Flag of Truce, Heroine, Amy Creed, James Cocker, Mary Keynes, Octoroon, Princess of Prussia, Miss Henshaw, William Lucas, Mrs. Eckford, very beautiful, Mrs. Thornhill, Flora Wyatt, Yellow Boy, Toison d'Or, Matilda, Mr. Dix, Lady Jane Ellis, Sir Greville Smyth, Lady of the Lake, James Backhouse, Golden Drop, Hon. Miss Herbert, Lilac Queen, Victory, Mrs. Bann, James Hunter, Julia Wyatt, John Harrison, Mrs. Boston, incomparable, Lady Gladys Herbert, King of Primroses, Emperor, Netty Buckle, Memorial, Jenny Austin, George White, Earl of Pembroke, Leah, splendid, and Norfolk Hero. Mr. H. May, of Bedale, is second with an excellent stand; John Dunnington, Baron Tannton, Memorial, High Sheriff, and Miss Henshaw being remarkably fine; while Mr. J. Harrison, of Darlington, and Mr. G. Edwards, of York, are respectively third and fourth, each having fine-sized, symmetrical blooms. Messrs. Kimberley; Milner, of Bradford; Draycott, of Hunsbstone; and Mr. Searle, of Sevenoaks, also exhibit good stands.

The best thirty-six come from Messrs. Draycott, who are first with a very even and fine set of blooms, consisting of Gazelle, Lady Jane Ellis, Norfolk Hero, Heroine, Lord Derby, Criterion, Volunteer, Annie Neville, John Dunnington, James Hunter, Blushing Fifteen, Julia Wyatt, Memorial, Princess of Wales, Mr. Dix, very fine, Firefly, Lilac Queen, Leah, Flag of Truce, Vice-President, Triomphe de Peep, John Kirby, Hon. Mrs. Wellesley, Miss Henshaw, British Triumph, Yellow Perfection, Eclipse, Mrs. Thornhill, Mrs. Boston, James Bennett, Juno, Lord Palmerston, Lady G. Herbert, George Brown, King of Primroses, and Sir G. Smythe. Mr. May, of Bedale, is second, and Mr. Keynes, of Salisbury, is third, each with fine blooms, Mr. Harrison, of Darlington, being fourth.

The best twenty-four come from Mr. Walker, of Thame, and comprise fine examples of Yellow Boy, Mr. Dix, John Kirby, Gazelle, Norfolk Hero, Hugh Miller, George White, Champion, and Mrs. Boston. Messrs. Kelway, of Langport, Somerset, are second; Mr. Clark and Mr. Pilcher, of Horsham, are respectively third and fourth.

By far the best stand in the amateurs' classes is Mr. C. J. Perry's twenty-four. In this there are very fine blooms of Lord Shaftesbury, Pink of Perfection, Head Master, Mr. Dix, King of Primroses, High Sheriff, Lady G. Herbert, Memorial, Andrew Dodds, Leah, Flag of Truce, George Brown, and Queen of Beauties; second, Mr. Pettfield, with excellent blooms; third, Mr. Burditt, Wandsworth Common; and fourth, Mr. R. Hopkins, New Brentford.

In twelves, the prizes went to Mr. J. P. Martin, Henfield, Sussex; Mr. Fewkes, Birmingham; Mr. Glassecock, Bishop Stortford; and Mr. Fry, Taunton.

The Fancy Dahlias are not very numerously represented; the best six in the amateurs' class are from Mr. C. J. Perry, and are Fanny Sturt, Pauline, Lightning, Prospero, Grand Sultan, and Bitterfly. Mr. Pettfield is second; Mr. Burditt third with large blooms; and Mr.

Fewkes fourth. In the nurserymen's class for twenty-four, Mr. Keynes is first with splendid blooms of Flora Wyatt, Flossie Williams, Sparkler, Hero of York, John Salter, Fanny Sturt, Chameleon, Leopardress, Richard Dean, and Attraction. Mr. May, of Bedale, is second with large blooms; and Mr. Draycott has a remarkably fine stand, in which Stafford's Gem, an old but most beautiful variety, rosy purple tipped with gold, is ever welcome; third, Mr. Walker; fourth, Mr. Edwards.

A first-class certificate was given for seedling Annie Hobbs, white self, shown by Mr. Hobbs, of Lewer Easton, Bristol; and a similar award was made to Fancy Dahlias, Flora Wyatt, buff ground tipped with purplish red; and Richard Dean, yellow, dotted and tipped with dark crimson. Excelsior, rosy purple, and Princess Mary of Cambridge, white, from Mr. Kimberley, of Coventry, are large well-built flowers, the latter less so than the former. James Cocker, rosy purple; and John Neville, yellow, are also very promising selfs.

Of Gladioli there is a very good though not large display. Messrs. Kelway take the first prize for thirty-six with fine spikes of Meyerbeer, Circe, Norma, Rosa perfecta, Etendard, Adolphe Brongniart, Prince Imperial, James Veitch (splendid), Eurydice, Sultane, Moliere, Marshal Bazaine, Lacede, Mr. Eyles, Madame Desportes, and Vandyke, and some others mostly as good. Mr. G. Wheeler, of Warminster, is second. For twenty-four Messrs. Stuart & Mein, of Kelse, are first with, among others, splendid examples of Madame Desportes, Robert Fortune, Delicatissima, Michel Ange (very fine colour), Meyerbeer, Marechal Vaillant, Moliere, and Bernard de Jossien. The second prize goes to Messrs. Draycott for a stand in which Virgile is conspicuous among several good spikes; the third and fourth prizes being taken by Mr. Edwards, of York, and Mr. Walker, of Thame. The best twelve come from Mr. Fry, of Taunton. In this stand are fine spikes of Etendard, Rosa perfecta, Moliere, and Ulysse. The second prize is taken by the Rev. H. H. Donbrain with excellent examples of Eleanor Norman, Madame Dembrain, Madame Furtado, Norma, and others. For six Mr. G. Rickwood, Ikley, Leeds, is first; Mr. Minchin, Hook Norton, being second.

Asters afford a very good display, although not so large on the whole as we have seen at former shows, a fact easily explicable by the extraordinary character of the season. The best thirty-six French come from Mr. G. Wheeler, the second best from Mr. W. Sandford, gardener to T. Thomasset, Esq., Maidenhead. The largest of these measure 4 inches across. The third prize was awarded to Mr. Walker, of Thame, and the fourth to Mr. H. Minchin. The best twelve come from Mr. G. Matthews, of High Street, Shore-ditch, who takes the first prize for beautifully incured flowers almost like show Chrysanthemums. Mr. Pettfield, gardener to G. Thornhill, Esq., Diddington, is second, and Mr. Jennings, of Shipston-on-Stour, third.

Of the German or Quilled Asters there is a good show, those from Mr. Wheeler, of Warminster, being particularly noteworthy. Two flowers in his stand, white bordered with violet, are very conspicuous. The second prize for twenty-four went to Mr. Walker, for blooms which, though larger, are not so refined; and the third to Mr. Betteridge, of Chipping Norton.

Verbenas are not numerously shown, but mostly excellent. Mr. Perry, of Castle Bromwich, takes the lead with remarkably fine trosses, of which Rev. C. Peach (purple), Mrs. George Prince, Mauve Ring, Modere, Edwin Day, Mrs. Mole, Diana, Rev. S. Hole (a lilac seedling), and Velocipede are most conspicuous. The second, third, and fourth prizes are taken respectively by Mr. Minchin; Mr. Fewkes, Birmingham; and Mr. Burditt, of Wandsworth.

Hollyhocks are shown both in spikes and as cut blooms. The best nine spikes are from Mr. Minchin; Mr. Chater, of Saffron Walden, being second; and Mr. Harrison, Darlington, third. As a whole the cut spikes are not so fine as we have seen. In cut blooms, Mr. Chater, of Saffron Walden, takes the first prize, and Mr. Minchin the second with blooms between which it would be difficult to decide; Mr. Harrison is third, and Messrs. Draycott fourth. For twelve blooms the prizes went to Messrs. Minchin, Fry, and Rickwood.

Cut Roses are shown by Messrs. Paul & Son, Keynes, Coppin among nurserymen, and by Messrs. Exell, Parnell, Perry, and Soder among amateurs, and are fair specimens for the time of year. Each of these exhibitors takes a prize.

In baskets or vases of cut flowers for table decoration, Miss A. Hassard, is first with a stand having Ferns, Grasses, and Pelargoniums in the bottom dish, and the top dish similarly filled, with the addition of *Lilium lancifolium*, the whole surmounted with an elegant egrette of Grasses, pink Pelargoniums, and blue Lobelias. The second prize went to Mr. Soder, gardener to O. Hanbury, Esq.; the third to Mrs. Donbrain, Westwell Vicarage, for a basket of Ferns, Caladiums, Vinca, Pelargoniums, Roses, Zinnias, and Stephanotis. Mr. D. McKay, of Sudbury, sent a stand of African Marigolds; Messrs. E. G. Henderson & Co., baskets of Tricolor Pelargoniums; and Messrs. Carter and Messrs. Downie, Laird, & Laing sent fine groups of plants, which were very tastefully arranged in front of the orchestra. For these special certificates were given; and certificates of the first class were likewise awarded to Messrs. Downie & Co. for Pelargonium Pink Queen; to Messrs. Paul & Son for *Cnrepussonia pendula alba*, a pretty variegated form of that handsome species; to Mr. Appleby for his simple and effective fumigator, and to Mr. Chapman for his excellent flower and fruit cases, which have been frequently noticed as admirable contrivances for transporting cut

blooms uninjured to a distance. Lastly, Mr. Chaff, gardener to A. Smee, Esq., Carshalton, sent some large specimens of Kitchen Apples, including Lord Derby, Lord Suffield, and Warner's King.

At the Judges' dinner on the first day of the Show, the Rev. H. Dombraïn presided, the Rev. C. P. Peach occupying the vice chair. Among those present were Messrs. Turner, Holmes, Dean, Fraser, Kinghorn, Standish, Cutbush, Edmunds, Lidgard, P. Barr, Wilkinson, Shirley Hubbard, Keynes, and several leading florists. After the usual loyal toasts the Chairman gave the Crystal Palace Company coupled with the name of Mr. Wilkinson, who, in replying, regretted the necessity which the managers had been under of discontinuing the Autumn Show, and expressed his pleasure at its revival under the auspices of the Metropolitan Florists' Society. Mr. Keynes in proposing "Success to the Metropolitan Florists' Society," coupled with the name of Mr. Dombraïn, said their meeting that evening put him in mind of old times, and expressed his great satisfaction at the excellence of the Show. The Chairman in acknowledging the toast remarked that he had received the most thorough encouragement from florists and amateurs, and that the entries had been nearly double the number of those at the last Crystal Palace Autumn Show. He trusted that the present Show would be the commencement of something that would permanently aid the cultivation of florists' flowers. Several additional subscriptions having been announced for next year, the meeting broke up.

ROYAL HORTICULTURAL SOCIETY.

SEPTEMBER 7TH.

THE subjects submitted to the Committees on this occasion were somewhat numerous, though those for which prizes were offered were only shown to a limited extent. The weather was extremely unfavourable, and the attendance of visitors proportionably small. Many of the plants, however, were very interesting, and in almost all cases good culture was evident.

Dahlias, Verbenas, and Liliams were the special objects of the day, but the show of these formed only a small portion of the whole, yet what were shown were shown well.

The show of Dahlias was but small, but the blooms excellent. In Class 1, for twenty-four, Mr. Walker, Thame, was first with Chairman, Julia Wyatt, Mentor, Flag of Truce, John Dunnington, Prince, Autocrat, Netty Buckle, Toison d'Or, Annie Neville, Gazelle, Mrs. Walker, Norfolk Hero, Lady Jane Ellis, George White, Queen of Beauties, Mr. Dix, Jenny Austin, Rosy Circle, Commander, Ne Plus Ultra, and Lottie Atkins. Mr. Burditt, gardener to C. Lambert, Esq., Wandsworth, was second.

In Class 2, for twelve, Mr. R. Hopkins, of New Brentford, was first with very fine blooms of Annie Neville, Chancellor, Sir Greville Smyth, British Triumph, Lady Gladys Herbert, and others also very good; Mr. Burditt was second with a good stand, and Mr. Adams, Wyke Green, was third. Mr. C. J. Perry sent excellent blooms, which, however, were too late for competition.

Several stands of seedlings were sent. Second-class certificates were awarded to Flower of Kent, yellow self, from Mr. Harris, of Orpington; and to Mrs. Watts, blush tipped with purplish lilac, from Mr. Parker, Maiden's Green, Winkfield, a very pretty variety.

Of Verbenas, Mr. C. J. Perry sent the only stand in his usual excellent style, including several seedlings, but these were too late for competition.

The only exhibitor of Liliams was Mr. W. Bull, who had a first prize for *laucifolium album* and *rubrum*, *L. tigrinum splendens*, *L. tigrinum Fortunei*, and *L. auratum maculatum*, the last named a beautifully marked variety with large segments and broad bands. The whole of these were most admirable specimens.

FLORAL COMMITTEE.—Mr. J. Fraser in the chair. From Mr. Pilcher, gardener to S. Rucker, Esq., Wandsworth, came a fine group of *Nerines*, of which the splendid scarlet heads of bloom, along with *Vallota purpurea*, formed conspicuous objects at one end of the room, Mr. King, gardener to S. Wiggett, Esq., Allanby Park, Binfield, sent two varieties of *Coleus* named *Bella Donna* and *Leopard*; the latter, green, veined and blotched at the base of the leaves with velvety dark purple, the prettier of the two. A special certificate was awarded to Mr. Denning, gardener to Lord Londesborough, for a fine collection of *Orchids*, in which were beautiful specimens of *Arides suavisimum*, *Cattleya superba*, splendid in colour; *Polycaenis muscifera*, *Burlingtonia venusta*, the rich yellow *Dendrobium chrysanthum*, *Oncidium incurvum*, remarkably fine; *Miltonia candida grandiflora*, and *Arides Hanthii*.

Messrs. Veitch also received a special certificate for a collection in which was a magnificent specimen of the white *Lapageria*, a plant of *Begonia Veitchii* in perfect health, bearing several of its showy scarlet flowers, and which had stood out of doors unprotected for the last three years, a number of elegant *Palms*, fine specimens of *Arides*, *Cattleyas*, *Lælias*, and other *Orchids*, new *Crotons*, and *Dracenas*, and several *Ferns*. First-class certificates were awarded to *Daphne elegantissima*, a variegated form of *D. indica*, in which the leaves are contorted and are edged with cream colour, a very pretty plant; to *Calamagrostis cinnamomea*, an elegant *Palm*; *Adiantum pervianum*, a

noble *Fern* with pinnæ of immense size; and to *Livistonia rotundifolia*, a handsome dwarf *Palm*.

Mr. Bull likewise received a special certificate for a very extensive collection, consisting of *Palms*, *Lilium auratum* in fine bloom, *Godwinia gigas*, the white *Lapageria*, *Cassia calliantha*, a very pretty plant; the variegated *Carex lucida recurvata*, *Ferns*, and *Dracenas*. A first-class certificate was given for *Damonoreps cinnamomea*, an elegant dwarf *Palm* with the young fronds cinnamon-coloured. *Chno-carpus dealbatus*, with glaucous foliage, is also an elegant *Palm*. *Ptychosperma nobilis*, a very handsome *Palm*, with the back of the leaves of a coppery tinge, formed a striking object in this collection, in which we also noted *Macadamia ternifolia*.

A special certificate was given to Messrs. Osborn & Sons, of the Fulham Nursery, for *Grevillea Banksii* of Hooker, producing two heads of its crimson and yellow flowers. A first-class certificate was awarded to G. F. Wilson, Esq., for cut spikes of *Lilium Leichtlinii* grown in the open border, the flowers having the segments recurved like the *Tiger Lily*, yellow, spotted with brownish crimson. Accompanying these was a splendid spike of the *Tiger Lily* of gigantic growth from an open border, likewise splendidly coloured flowers of *Lilium speciosum rubrum*. Messrs. E. G. Henderson & Son, Wellington Nurseries, had a special certificate for baskets of *Silver Tricolor Lass* of Gowrie and *Golden Tricolor Peter Grieve*, with the leaves beautifully coloured. Messrs. Henderson likewise sent a collection of *Tricolors* in small pots.

From Messrs. J. & C. Lee, came a very interesting collection of cut specimens of hardy trees and shrubs, which had a special certificate; from Messrs. Carter & Co., of Holborn, flowers of a large variety of *Lilium speciosum*, imported from Japan; from Messrs. Bell & Thorpe, of Stratford-on-Avon, nicely-marked *Petunias* and seedling *Pelargoniums*, of which *David Garrick*, a *Nosegay*, with immense trusses of crimson scarlet flowers with a glow of purple, received a first-class certificate, a distinction which it thoroughly deserved. Mr. Cocks, gardener to G. S. Cudwell, Esq., Clapham, exhibited several seedling *Colenses* and a yellow-leaved *Pelargonium*. Mr. Cannell, of Woolwich, sent a pretty *Gold* and *Bronze Pelargonium*, called *Champion* and *Pride of Kent*, with scarlet flowers 2 inches in diameter, and fine, very dark-zoned foliage; also Mrs. J. C. Mappin, white-variegated and white-flowered.

Mr. Eckford, gardener to the Earl of Radnor, Coleshill, had a second-class certificate for *Verbena Miss Charlotte Mildmay*, rose, with a pale edge. He also sent *Rose Imperial*, with very large pipes of a lilac rose colour, *Lavender Queen*, a pretty variety, and two other seedlings, likewise seedling *Dahlias*. Mr. Searle, gardener to R. C. Steel, Esq., Marlesford Lodge, Hammersmith, sent *Lobelia Miss Steel*, of a very dark blue, with a rather large white eye, a very effective variety, though, perhaps, not sufficiently distinct.

Mr. Green, gardener to W. Wilson Saunders, Esq., Hillfield, Reigate, sent a most interesting collection. *Stangeria paradoxa*, of which there was the female plant in fruit, as well as the male plant bearing two cones of indolescence, received a special certificate. This, we believe, is the first time the plant has ripened fruit in this country. A second-class certificate was given for *Griffithia dryades*, with violet blue flowers, white in the centre of the segments. *Amaryllis Belladonna pallida*, a pretty variety, pale blush, more or less tinged with pink, came from the same exhibitor.

Messrs. Lee, of Hammersmith, had a first-class certificate for *Thuja semper-aurea*, a beautiful golden *Arbor-Vitæ*, far more golden than the *Thuja aurea* sent for comparison.

Mr. H. Bennett, Manor Farm Nursery, Stapleford, sent a box of *Clarence Raoux Rose*; Mr. George, gardener to Miss Nicholson, Putney Heath, stands of cut flowers of seedling *Nosegay Pelargoniums*; and Mr. Green, gardener to W. Wilson Saunders, Esq., a new Composite plant from *Chirique*, with ample foliage silvery at the back. A special certificate was given to Mr. C. J. Perry for his collection of seedling *Verbenas* previously noticed.

FRUIT COMMITTEE.—G. F. Wilson, Esq., F.R.S., in the chair. On this occasion prizes were offered by Messrs. Osborn, of Fulham, for the best bunch of *Golden Champion Grape*, but, unfortunately, there was hardly any competition. Mr. Sage, gardener to Earl Browlow, Ashridge, took the first prize with bunches which were large, symmetrical, and with large berries, though rather green in colour, each bunch weighing 3 lbs. Mr. Douglas, gardener to F. Whitourn, Esq., Loxford Hall, Ilford, had bunches of the same *Grape* from a *Vine* grafted on *Trentham Black*, and the latter seemed to have imported some of the dark hue and oval shape of its berries into the *Golden Champion*; the berries, too, were very much smaller than those of that kind generally are. From G. F. Wilson, Esq., came *Early Ascot Frontignan*, which he had found to be valuable for cold orchard-house cultivation, being a fortnight earlier than *Chasselas Musqué*, alongside of which it had been grown. The latter, exhibited from the same house, was decidedly unripe, while the former was perfectly so, and of delicious flavour.

Mr. C. Noble, of Bagshot, sent a seedling *Peach*, *The Lady*, which was considered to be no improvement on existing varieties; and a seedling *Nectarine* resembling *Pitmaston Orange* was also exhibited. Messrs. Lee sent *Royal Vineyard Peach* grown on pot trees; this variety is considered to be very hardy.

Mr. Sage, Ashridge, exhibited a small collection of *Apples*, *Figs*, and *Filberts*; Mr. Francis Dancer, of Little Sutton, Chiswick, Pond's

Seedling and other Plums, of which the excellence justified his high reputation as a cultivator of this fruit; and Mr. Cox, of Redleaf, Bnyard's Early Apple, a small but excellent variety. Messrs. Carter and Co. exhibited their Chinese Mustard, together with the white and black kinds, but the Chinese, though delicate and pungent, was not considered sufficiently distinct for an award. Mr. Clarke, of Whitton, exhibited Whitton Pippin, a very showy high-coloured Apple; Mr. Catlough, Chelsea, a fine specimen of Puffball; Mr. Sage, of Ashridge, fine heads for the season of Dwarf White Celery; and Mr. Cadger, of Luton Hoo, three seedling Cucumbers of great size, but coarse. Mr. Dean sent fine Onions under the name of Danvers' Yellow selected from plants raised from Vilmerin's seed, but the Committee considered they were not the true Danvers' Onion. Finally, Messrs. Sutton and Sons, of Reading, had a fine collection of fifty kinds of Potatoes, to which a special certificate was given.

GENERAL MEETING.—W. Wilson Saunders, Esq., F.R.S., in the chair. The Chairman, in opening the proceedings, regretted the absence of the Rev. Joshua Dix, who had been struck down by serious illness, but who, he was glad to learn, was on the previous evening very much better, and called on Mr. Moore to report the awards of the Floral Committee. This having been done, and Mr. Wilson having performed a similar task as regards the Fruit Committee, the Chairman, in the absence of Mr. Berkeley, pointed out the most remarkable of the plants exhibited, first noticing the beautiful group of *Nerine Fothergilli* and *Vallota purpurea* from Mr. Incker's gardener. Of the latter plant it was evident there were two varieties in the collection; the one was the plant as originally received, the other the plant as improved by raising from seed and crossing. The increased size of the petals and flower was most noticeable, added to which a yellowish tinge had been imported into it, all tending to show that the plant had entered upon the road to variation. It was a highly ornamental plant, and the great secret of its successful cultivation was to keep it in a greenhouse temperature, with the soil damp at all times. The singular *Godwinia* from Mr. Ball, with its mottled stem-like leafstalk and single leaf, was then pointed out, and several of Messrs. Lee's specimens of ornamental trees and shrubs were also noticed, especially the variegated *Cornel* and *Judas-tree*, *Quercus Concordia*, and a Lime tree with leaves which, instead of being cordate, were lobed in all fashions. *Lilium Leichtlinii* next came under notice, and it was remarked that the plants which attracted the attention of one generation of men were passed over by other generations, that the attention of one set of men was attracted to one thing, that of another set to another; but the Lily had held its ground for several thousands of years. That referred to, he thought, would be produced some day in great perfection. The Chairman then called attention to the *Stangeria paradoxa* from his own garden—a plant which had been a puzzle to botanists, but on which he expected further light would soon be thrown. The result of placing stamiferous and female plants together some three months ago had been the fruit before the meeting.

The Chairman said he had now to state that the Council had come to the determination to hold the country show of 1871 at Nottingham, and the show there, not being in conjunction with the Royal Agricultural Society's show, would take place at a season when plants were to be seen in their greatest perfection. The date had not been as yet fixed, but it would be announced at the next meeting, September 21st.

GARIBALDI STRAWBERRY.

In a recent issue I noticed a correspondent recommending a new Strawberry named Garibaldi. Now, I do not want to question the veracity of those sending the Strawberry out by this name as a new one, but suffice it to say that last year a Strawberry was sent out under that name, and which has now been proved to be *Vicomtesse Hélicart de Thury*. Many people are still sceptical as to the value of this Strawberry. I can with confidence recommend it as the most useful Strawberry in cultivation. It appears to adapt itself to every soil and climate. While other Strawberries droop and fade it remains fresh and green, and bears an enormous quantity of peculiar-flavoured fruit. As a proof of its great productiveness when true, two rows of one hundred plants each, as a trial, and very badly grown by a market gardener, produced 400 lbs.; and at Glasgow June Show Mr. Matthew Campbell, nurseryman, Blantyre, exhibited three plants taken from a field of thousands, where all were equally good, with one hundred ripe Strawberries and more than two hundred altogether, and it was allowed by competent judges to be fully 3 lbs. on each plant.—W. THOMSON.

LILIUM ACUTUM.—A bulb of the above fine Lily was planted by Mr. A. Anderson, gardener to J. C. Burns, Esq., Glenlee, Hamilton, about three years since in a 14-inch pot, and once shifted into an 18-inch one, the plant has this year grown to

the height of from 10 to 12 feet, carrying 120 flowers—a number which I have not yet seen excelled.—W. T.

THE GARDEN PINK FOR FORCING PURPOSES.

THE Garden Pink, in its several varieties, has always been, and will, no doubt, long continue to be, a special favourite. Everybody loves the modest beauty and delightful fragrance of its flowers, and many consider it as only inferior to the Rose itself. One or two varieties of this Pink have been generally found very useful for forcing into flower during the winter and early spring months; and I would here call attention to a few other sorts, well suited to the same purpose, but which are not so well known as they should be.

The varieties mostly used for forcing are the Common, or London White, a fragrant and very useful sort; and a larger dark variety known by the name of Anne Boleyn, and which produces exceedingly beautiful and very sweet-scented flowers, but has the great drawback of being addicted to bursting its pod or calyx. Observing and regretting this defect, an enthusiastic amateur florist, Rowland Dalton, Esq., of Bury St. Edmunds, many years since, after much perseverance, succeeded in originating a variety with flowers of the same colour, somewhat smaller, similar in habit, equally fragrant, and possessed of all the forcing properties of Anne Boleyn, but with the advantage of having a strong, well-formed calyx, which never by any chance bursts; and this very useful variety was named Claude. He afterwards succeeded in raising another still more beautiful variety, which he named Plato, and this is a truly magnificent flower of a beautiful rose colour, with a finely-formed, strong calyx, quite free from bursting, and it proves to be also a fine forcing sort, coming into flower earlier than Anne Boleyn.

Another amateur florist residing in the same town, Mr. J. Clarke, who has made the cultivation of the Pink quite a speciality, has, amongst many other triumphs in that way, originated an exceedingly fine variety resembling the old favourite Anne Boleyn, but a great improvement upon it, being more compact in habit, and producing in wonderful abundance finely-formed, large, sweet-scented flowers, with a firm strong calyx, which never bursts. This fine variety, which is exceedingly well adapted for forcing, was named Garibaldi. The same raiser also originated another splendid sort, which he named Clarke's Lord Lyons, but this variety, although exceedingly beautiful, is in all respects very nearly identical with Dalton's Plato. Some years since the Messrs. E. G. Henderson and Son sent out a most useful variety under the name of Most Welcome. This is also excellent for the purpose of forcing, and may be considered as an almost perpetual flowerer, in addition to which it is possessed of all the qualities of a first-class florists' flower, and is quite free from bursting, either when forced, or when grown in the open air.

The treatment of these plants for the purpose of forcing is so very simple, that little need be here said upon the subject. During the month of March, or early in April, cuttings should be taken from plants which have been forced, and inserted in a compost made up of sand and sifted leaf soil, using pots of some 6 inches diameter; place them in a gentle hotbed, and in all respects treat them as cuttings of *Verbenas*, although they will not root so quickly as the latter. When rooted, pot them singly into 3-inch pots, and gradually harden off, and towards the end of May or early in June plant them out in the open border, in any convenient situation, in rows about 15 inches apart, and about 1 foot from plant to plant. While here let them have abundance of water when required.

During the first fortnight of October they should be carefully raised and potted into pots some 5 inches or 6 inches in diameter, using soil composed of turfy loam, enriched with a little well-rotted hotbed manure, or leaf soil. They should be placed in a shaded position for a short time, and ultimately wintered in a cold pit, from which they are to be introduced to the forcing-house as may be required. When this is done, it is necessary that the plants be kept as close to the glass as possible. Perhaps no better situation can be found for them than a shelf on the back wall of an early vinery or Peach house at some 18 inches from the glass.

With the varieties I have mentioned—viz., Common White, Claude, Garibaldi, Plato or Lord Lyons, and Most Welcome, assisted by a few of the perpetual or winter-flowering *Carnations* and *Picotees*, little difficulty will be found in keeping up

an ample supply of these fragrant flowers throughout the entire year.—P. GRIEVE, *Culford*.—(Florist and Pomologist.)

A LARGE OAK TREE.

On the outskirts of the park of Sir William Smith Marriott, Bart, of Horsemonds, in Kent, stands a very fine Oak tree with a healthy top and straight bole. The circumference, at about 5 feet from the ground and in the smallest part between the root-claws and the first branch, is 21 feet, the bole appearing to be perfectly sound, or at all events there is no outward indication of decay of any consequence. The appearance of the upper part of the tree would indicate that the decline of life had scarcely, if at all, set in. Some limbs had been broken off, but these looked more as if by the effects of high winds or other accidents than the decay of nature; and the top, as a whole, was not so large as is often met with in much smaller trees. The situation was on the top of a slight embankment, caused by the making of a sort of dry moat or excavation 5 or 6 feet deep, the roots of the noble tree clasping the sides of the bank, and presenting an extended mass of root timber rarely met with, showing their naked surfaces along the side of the bank for some distance, swollen and enlarged so as to resemble a kind of irregular ribbed work, and finally disappearing at the bottom of the moat, which was perfectly dry. The soil, I should think, was of the kind common in the neighbourhood—a decomposed sandstone, and sandstone formed the substratum; it was evidently well suited to the growth of this tree by the good examples to be seen around.

Another fine tree is pointed out as having been all but sacrificed at one time to a mistake. Some workmen sent to cut oak timber in this park had actually stripped the bark of the lower part of the trunk prior to felling it, when the mistake was discovered, and the bark nailed on again so carefully that no vestige of the operation is to be seen, excepting a ring mark round the tree at about 3 feet from the ground. This tree, although much less than that previously noticed, is a fine specimen, and I believe tempting offers have been made for it by purveyors to the navy and others. The hole where the girth was made is as nearly circular as could be guessed, and free from any bulges or swellings that increase the measurement. I should think that at 30 feet up it would be 16 or 17 feet in circumference. It grows on the escarpment of a moat, which may, for anything I know to the contrary, have formed the boundary of an entrenched camp.—J. ROBSON.

BLUEBELLS AND HAREBELLS.

In your Journal of August 25th, page 151, I read, "The common wood Hyacinth is the *Scilla nonscripta* of botanists, the Harebell of common nomenclature." I presume you mean the "Bluebell" of common nomenclature. *Campanula rotundifolia* is the Hare (or Hair) Bell, but I believe it is usual to call both "Bluebells," though the *Campanula* is "the Bluebell of Scotland."—BLUEBELL.

[It is quite certain that the Harebell is the *Hyacinthus non-scriptus*, or *Scilla nonscripta*. Two of our oldest botanical writers, Gerard and Parkinson, portrait it, and call it "Harebells," probably from the Anglo-Saxon, *har*, grey, and *belle*, a bell. The "Bluebell" is the *Campanula rotundifolia*, according to our best modern authorities, but when or by whom the name was first applied we cannot tell, for all the old herbalists call it the "Small round-leaved Bell-flower." The name "Hairbell" applied to this flower on account of the fine hair-like stalk of the flowers, is of very modern invention, though probably for its aptness it is adopted by Babington and Hooker. Dr. Hogg in his "Vegetable Kingdom," says that *C. rotundifolia* is "the lovely little Scotch Bluebell." We have always heard it so called, and we will conclude by quoting—

"Then strike the loud harp to the land of the river,
The mountain, the valley, with all their wild spells;
And shout in the chorus for ever and ever,
The Bluebells of Scotland, the Scottish Bluebells."]

NEW AMERICAN POTATOES.

SEEING the interest that is felt in the new American Potatoes which have been so highly spoken of, I forward the results of a trial on a small scale, which may be interesting to some of your readers, and is strictly reliable, as I weighed and counted the Potatoes myself. The Potatoes were imported in December, and planted on January 21st. A large proportion in weight of

each kind consisted of handsome useable Potatoes, but in the count and weights given I have included every small tuber down to the size of a marble. I may remark, that having so few of each sort I cut them into as many sets as there were eyes, and no doubt the produce would have been much larger had small seed Potatoes of the same weight been planted. The five Canadian Kidneys sent to me prove to be identical with a similar number I received from my brother in Canada four years ago, and from which I have succeeded in raising a large stock. I have no hesitation in saying that it is the best eating Potato I ever met with, and has the valuable property of keeping good until late in the year.

Early Rose.—Four Potatoes, weighing 1 lb. 5½ ozs., cut into twenty sets, and dug on July 28th quite ripe, producing 161 Potatoes weighing 21 lbs. 6 ozs.

Garnet Chili.—Five Potatoes, weighing 2 lbs. 4½ ozs., cut into twenty-eight sets, and dug on August 31st not quite ripe, but had begun to grow again, producing 212 Potatoes weighing 50½ lbs.

Canadian Kidney.—Five Potatoes, weighing 2 lbs. 1 oz., cut into twenty-seven sets, and dug on August 1st quite ripe, producing 160 Potatoes weighing 32 lbs. 12½ ozs.—JOHN J. STONE, *Seyhorwen, Llanelisant*.

ROSES NEW AND OLD.

I ALWAYS read Mr. Radclyffe's and Mr. Kent's contributions to Rose lore. They do not purloin and hash-up other men's thoughts, but write independently from their own observation and experience: there is, consequently, a freshness and individuality about what they offer. Further, Blechingley and Okeford Fitzpaine are far apart, and the soils are so diverse that it is interesting to know how differing seasons affect the varieties of Roses, whether new or old, in different localities and soils. I can quite understand that a new Rose, when the stock is limited to two or three plants, does not always reveal its true character for one or even two seasons, and it is better to speak under reserve when doubts exist, than to speak positively and have to retract. The latter plan does not really inform, although it may appear to do so, but it often misleads. The "latest intelligence" is, doubtless, important when the authenticity of it can be guaranteed. But the experience of life is beginning to teach me not to be guided so much by the thing said, as by who says it.

The best dozen of the older Roses were with me this year—Alfred Colomb, Baron Haussman, Edward Morren (not always good but sometimes very fine), Elie Morel, Horace Vernet, Madame Fillion, Madame Noman (valuable as a white), Mille Marie Rdy, Marie Baumann, Monsieur Journeaux, Perfection de Lyon, Souvenir de Monsieur Boll (very fine on the old but not so good on the young plants), and Souvenir de Monsieur Poteau. It will be observed that I have avoided here the very old kinds, on the assumption that their merits and demerits are already sufficiently well known. My soil is strong, cool, and moist, and my system of cultivation is directed to the development of bone and muscle rather than of fatty matter.

Of the new Roses I speak under reservation, but the following have been satisfactory with me:—*Hybrid Perpetuals*: Albion, Baron Charand, Comtesse d'Oxford, Louis Van Houtte, Madame Dustour, Mademoiselle Eugénie Verdier, Marquise de Castellane, Paul Neron, and Princess Christian. *Tea-scented*: Belle Lyonnaise, Madame Ducher, and Madame Hippolyte Jamain. *Perpetual Moss*: Madame William Paul. I find that I have in each case given a baker's dozen, but full measure is a good rule, and seldom leads to difficulties.—WILLIAM PAUL, *Paul's Nurseries, Waltham Cross, N.*

FLOWER-BED ARRANGEMENTS.

YOU frequently tell us in "our Journal" that you make a rule of not offering suggestions for planting flower gardens, but you criticise plans sent to you of those planted. Now, myself and two sisters are fond of flowers (the fat baby don't take much notice of them yet), and we have a small flower garden laid out on the grass, a copy of which we enclose for your inspection. We all claim our separate beds, though at planting time we pay due regard to order, and so have the beds to match with each other. In the afternoons we spend many happy moments in picking off dead flowers, and otherwise making things look neat. As we are but little girls we cannot mow the grass, but two of our father's men run the machine over it once a-week. Next year we want a perfect arrangement of colours,

though this year the beds in themselves are as good as they can be. We have no failures, though the yellow Pansies are hardly up to the mark for bedding. Beds 10 and 11 are grand, and as for 2 and 3 we cannot describe their glories. My father wishes Mr. Peach could see them and another bed or two that we have elsewhere of William Thomson and Douglas Pearson, and then he says he would not write about such rubbish as Waltham Seedling and others as useless. Bed 8 is also grand, and you must tell everybody who wants an effective bed to grow Miss Kingsbury.

The following is the way the beds are planted:—Bed 1, *Centaurea candidissima*, edged with *Amaranthus melancholicus* tuber, with a terra cotta vase in the centre filled with Violet Hill Nosegay, and margined with a pretty variegated Ivy-leaved Geranium; all very good. Bed 2, Bayard Geranium, edged with *Cerastium tomentosum*. Bed 3, William Underwood, edged the same as bed No. 2. Beds 4 and 5, Amy Hogg Geranium, edged with yellow Pansies. Beds 6 and 7, Geranium Madame Rindersdorff. Bed 8, Miss Kingsbury Geranium, edged with Blue Lobelia. Bed 9, Bijou Geranium, edged the same as bed 8. Miss Kingsbury is the best white-edged Geranium. Beds 10 and 11, Mrs. Pollock Geranium, edged with *Cerastium tomentosum* and *Lobelia speciosa* in links of about 15 inches long all round the beds, and a few plants of *Verbena venosa* interspersed among the Geraniums, the effect of which is good. Beds 12 and 13 are *Verbena Purple King*, edged with Cloth of Gold Geranium, and are very good. All the plants have grown well, and we could not wish them to be better. All we want is a different arrangement of colours. Now we hope our old friends will help us—we should have liked to have said our "old Gooseberries."—SARAH ANN, CLARA, AND AMY ALICE, *Geranium Cottage, Beulah*.

[The reading of your letter does one good. We are sorry to say that we feel almost helpless as regards advising you to do better. One thing we may note, however, with respect to the garden; the centre is as simple and neat as it well can be, consisting of a circle, with another circle divided into four clumps round it. The circles and two ends are all that could be wished, as all are bounded by curved lines so pleasant to the eye. The

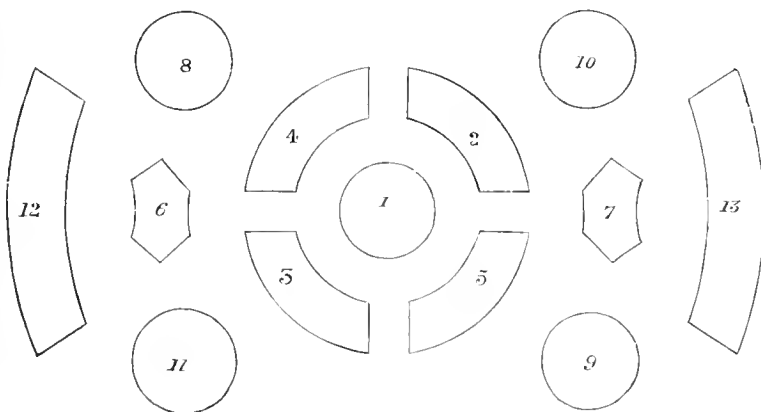

object to the sameness, we would edge all these four beds with a string of small plants of the Feverfew, and have a line behind of the Alyssum and the Lobelia mixed; 6 and 7 might be edged with *Cerastium*, and a thin line of purple *Verbena* inside would improve it. Nos. 8 and 9 we would edge with a bluish purple *Verbena*, with a string of *Cerastium* round it, and thus the four beds would be something alike; 10 and 11 cannot be improved; we think we see the looping of the Lobelia. 12 and 13 are no doubt neat, but the big leaf of the Cloth of Gold is rather too much for the Purple King *Verbena*. We would be inclined to centre the beds with yellow *Calceolaria*, and then fill up with the purple *Verbena*. The "Old Gooseberries" have expressed even these ideas, however, with great diffidence.—Eps.]

two clumps 6 and 7, with their irregular six-sided straight lines, break in on the general regularity. A bed smaller, but shaped like those round the circle, made with the ends concave to suit the circle on each side, would, we think, be more appropriate. As you do things so well, we would like to see you try a 14-inch mowing machine, even if two should work it. You cannot tell how much we admire the good sense which leads you, though having separate beds under your especial control, yet to agree so to plant that the whole garden shall form a harmonious whole. Under similar circumstances we often see nothing but confusion, owing to each young lady following her individual tastes. Where there cannot be such agreement as to planting, as in your case, we think it best that every young lady should have a bed or beds, far apart, so that each could be judged separately.

In making a change in No. 1, you could place scarlet in the centre of the vase, draped as now, or with the white Ivy-leaved Geranium; then fill the bed with *Coleus Verschaffelti*, and edge with the Centaures, or, better still, with *Polemonium caruleum variegatum*, as at Woburn. The four beds round you can hardly be better, and you might edge all alike, or two and two; but if you had a whitish edging for No. 1 we would not have *Cerastium* for 2 and 3, but a mixture of variegated Alyssum and blue Lobelia. Instead of yellow Pansies we would edge the other two with Golden Feverfew. If you did not

object to the sameness, we would edge all these four beds with a string of small plants of the Feverfew, and have a line behind of the Alyssum and the Lobelia mixed; 6 and 7 might be edged with *Cerastium*, and a thin line of purple *Verbena* inside would improve it. Nos. 8 and 9 we would edge with a bluish purple *Verbena*, with a string of *Cerastium* round it, and thus the four beds would be something alike; 10 and 11 cannot be improved; we think we see the looping of the Lobelia. 12 and 13 are no doubt neat, but the big leaf of the Cloth of Gold is rather too much for the Purple King *Verbena*. We would be inclined to centre the beds with yellow *Calceolaria*, and then fill up with the purple *Verbena*. The "Old Gooseberries" have expressed even these ideas, however, with great diffidence.—Eps.]

WINTER-BLOOMING ORCHIDS.—No. 6.

LÆLIA.

I SHALL now resume my brief notes upon this subject; I very much regretted my inability to continue them in due course, but 1870 has been an unusually busy season with me, and the exceptional weather we have experienced has materially increased my work.

The genus *Lælia* bears a strong resemblance to *Cattleya*, and to an ordinary observer it would be impossible to point out the difference, which lies only in the last-named having four pollen masses, whilst the other has eight; indeed, one of the highest living authorities upon these plants merges both genera into *Epidendrum*, an arrangement which is not likely to find much favour with English Orchid-growers, however correct it may be in a scientific point of view.

The genus now under consideration contains many fine species, some of them summer-flowering, which, as a matter of course, must be left out in this place, and I will, therefore, proceed to give a brief description of the charms, and how to produce them, of the kinds flowering in winter. A fact very much in favour of these plants is, that most of them are amenable to cool treatment; those which require to be grown in pots should have good drainage, and be potted in equal

parts of fibrous peat and sphagnum moss, adding some pieces of charcoal. During the growing season an abundant supply of water may be given, both from the watering-pot and syringe, at the same time strictly observing that none is allowed to lie in the sheaths which envelope the young growths, for if this occurs ruin is most likely to follow and that speedily. After growth is completed gradually withhold water until the short dull days set in, when only just sufficient must be given to prevent shrivelling until the flowers begin to swell, when a little extra warmth and moisture will be advantageous. Should any of the plants show signs of shrivelling remove them to a warmer place and water carefully, it is a sign the energies of the plant have been overtaxed.

L. ACUMINATA should be grown upon a block of wood, and made fast to it with a little sphagnum moss. I have seen it grown in pots, but it makes comparatively little root, and in a pot it is apt to rot. The flowers are produced, several together, upon the top of a slender scape proceeding from the apex of the short, somewhat ovate pseudo-bulbs. The leaf is short and oblong, thick, and dark green. The sepals and petals are of a waxy white; the lip is also white, stained towards the

base with a dark rosy purple blotch. It blooms in the very depth of winter, and if the flowers are not wetted it retains its beauty several weeks. For bouquets it is very useful, and for gracing a lady's hair it is very effective. It is a native of Mexico.

L. ACUMINATA PEDUNCULARIS.—This resembles the preceding in general appearance, and manner and time of flowering. It is considered by many a distinct species, but it has little but colour, in my opinion, to distinguish it, the flowers being of a uniform rosy purple, offering a lovely contrast to the waxy white of *L. acuminata*. Native of Mexico.

L. ANCEPS.—A plant of robust habit, which thrives best in a pot. The pseudo-bulbs and leaves are dark green, and from 6 to 12 inches in length, the latter oblong-acuminate. The flowers are produced, several together, upon a stem about

18 inches long. They are thick and fleshy, and last a very long time without the least sign of fading. The sepals and petals are in colour soft rosy lilac, whilst the lip is suffused with various shades of rich dark purple. The entire flower measures about 3 inches in diameter. This is a most pleasing and useful kind. Native of Mexico.

L. ANCEPS DAWSONII.—This charming variety is of recent introduction, and is still very rare. The habit is exactly that of *L. anceps*; the flowers, however, are very different, for the sepals and petals are of the purest waxy white, whilst the rich purple lip is relieved with the addition of white lobes, and is tinged with yellow. It requires the same treatment as the preceding. Native of Mexico.

L. ALBIDA.—This species should be grown upon a block of wood, and as it is very reasonable in price it is within the reach



Lælia superbiens.

of all; therefore I say, Have several large blocks of it in the collection, for it is one of the most elegant winter-blooming plants it is possible to conceive. The pseudo-bulbs are small, and nearly round, bearing a single leaf; the flowers are borne upon a spike some 6 or 9 inches long; the sepals and petals are white, the lip rosy pink, streaked with yellow towards the base. In some of the varieties the sepals and petals are of the same colour as the lip. The flowers of *L. albida* are thick and fleshy, and last a long time in full beauty. This species may be grown successfully in a Wardian case, if suspended from the roof. It is a native of the cool parts of Mexico.

L. AUTUMNALIS is another kind which may be obtained at a

low price, thanks to the persevering collectors who have sent such quantities home. It succeeds best on a block of wood, although it is a more robust-growing kind than the last, and the flowers are proportionately larger, measuring between 3 and 4 inches in diameter. The sepals and petals are rosy purple, and the lip is the same colour, with a few white markings, and streaked with yellow towards the centre. It blooms in December and January, and produces a beautiful effect for several weeks. Native of Mexico.

L. FURFURACEA.—This is very similar in growth to *L. autumnalis*; the flowers, however, are very distinct, being both larger and different in colour, but it does not produce them with me

very freely. The sepals and petals are of a rich rosy purple, passing into dark purple in some varieties, and with a bright rose lip. The flowers are usually produced in autumn. It should be grown upon a block. Native of Mexico.

L. SUPERBIENS.—A superb species, and one that may be regarded as the giant amongst *Lælias*. The pseudo-bulbs are long, and support a pair of oblong-acute dark green leaves, from between which the flower spike is produced, and which extends upwards of 5 feet in length, and bears towards the top from twelve to twenty of its fine flowers, each of which is usually between 3 and 4 inches in diameter. The sepals and petals are bright rose suffused with red and reddish crimson; the lip is crimson streaked with yellow. It lasts in beauty during the greater portion of the winter months. It should be grown in a pot in the cool house. Native of Guatemala, &c.

L. PERRENI.—This should be grown in a pot, and be placed in a temperature a few degrees higher than any of those previously named. The pseudo-bulbs are slender, supporting a large, oblong, very dark green leaf. The flowers are produced from a spathe at the base of the leaves. The sepals and petals are somewhat narrow, in some varieties light, in others dark purple; the lip is contracted and rich crimson in front. It is a very handsome species, producing its flowers in autumn. Native of Brazil.—**EXPERTO CREDE.**

WORK FOR THE WEEK.

KITCHEN GARDEN.

It is now favourable weather for performing all necessary operations in this department. If the grass in any of the *Asparagus* beds is withering, and ground is scarce, cut it over if quite yellow, and plant a row or two of *Endive* and *Lettuce* for late work. Young *Cabbages* just through the ground should have a little soil thrown among their stems if intended to remain where sown. Plant the principal crop of spring *Cabbages* in well-manured ground. The East Ham is found to be a good variety for standing over the winter; it is not so prone to run to seed in spring as most sorts. Prick out into beds a few inches apart a large quantity of *Cabbage* plants which have just expanded their two first rough leaves; they will be required in spring. All *Herbs*, if not gathered, should be cut immediately. Quick drying is proved to be the best mode, for the same reason that quick bay-making exceeds a lingering process. *Sweet Basil* should be bunched and hung up in a hot kitchen, also *Sweet Marjoram*. When thoroughly dry let them be immediately packed closely in boxes, so as to exclude all air; indeed, bottled herbs sealed up after this treatment are very superior.

FRUIT GARDEN.

The summer fruit season being now nearly ended, attention must be paid to the gathering at a proper period, and storing away in a proper manner, the keeping winter stock. It is a somewhat nice point to know when to gather the respective fruits, some being best at one stage of the ripening process, and some at another. As a general rule, fruits of a precocious character, and which ripen rather hastily, and those also possessing some aroma, should be gathered somewhat under-ripe; while those which ripen with difficulty, which are long in gaining colour, and those which are scentless, should remain much longer on the trees. Certainly the way to obtain the greatest amount of flavour is to suffer fruit to become ripe on the tree, but I think that longer keeping is secured by gathering rather earlier. The colouring of the pip or seed is, perhaps, the most sure criterion; if it is one-half coloured it will seldom be wrong to gather the fruit. It need scarcely be observed that much care must be exercised in handling fruit for long keeping, especially the *Flemish Pears*. Some have advised them to be handled like eggs; the latter, however, will bear a much rougher handling than some *Pears*, many of which possess a fine skin, and are very susceptible of bruises. The *Pears* should only be placed one layer in thickness, if possible, and for material nothing is found better than cap paper, where the shelves are solid, placing the cap paper double. *Pears* require less ventilation than *Apples*; the latter are apt to give out a large amount of moisture when first placed in the room, especially if full of juice through rain. The *Pears* for long keeping may in such cases have something laid over them, in order to prevent excessive perspiration.

FLOWER GARDEN.

If previous directions have been attended to, the propaga-

tion of next year's bedding stock will by this time be well advanced, and where, from the pressure of work or other causes, this is not the case, every possible dispatch must be used while the weather is favourable. When cuttings of *Verbenas* and similar plants have yet to be put in, they should be inserted rather thinly in deep pans or shallow pots, in which they can be wintered, as they will be sooner established in this way than would be the case if they were potted-off before winter; and late cuttings managed in this way frequently winter quite as well as stronger plants, and unless plants are intended to furnish cuttings in spring, it is very immaterial how small bedding plants are before winter, provided they are well rooted, without having been raised in a close, warm atmosphere, to render them sappy and tender. Many through anxiety to secure large plants keep bedding-out stock close and moist until late in autumn, and frequently in frames on dung beds, where size is soon obtained, but plants treated in this way are necessarily so soft and tender that it is almost impossible to carry them over the winter without serious loss. Therefore, avoid keeping such plants too warm after this season, and if they are planted in bottom heat give air at night, and whenever it can be done, without the cuttings flagging, so as to prevent weakly growth. See to staking late *Asters*, *Phloxes*, &c., of tall growth, otherwise the autumn storms will destroy them prematurely. Choice *Hollyhocks* for seed should have the decaying corollas plucked out; this greatly helps the formation of seed. Make observations on the colour and general character of the flower garden before the season closes, in order to improve it next year. After studying the individual effect of flowers, let collective effect receive a consideration, as well as proportion, outline, and the combination of colours. *Anriculas*, if not already potted for the winter, should be potted without delay. Remove suckers or offsets, and place these round the sides of the pots, which should be 6 inches in diameter. *Anriculas* are impatient of rich compost during winter; turfy loam, river sand, and very rotten horse dung, will make a suitable compost, using only a small portion of the two latter. It is far better to give them a strong top-dressing in the spring, than to use soil of too strong and forcing a nature for their winter food. In consequence of the general weakness of *Tulip bulbs*, it will be advisable to put a small portion of decayed manure and leaf soil about 2 or 3 inches beneath the offsets. It is argued, and with some show of reason, that manure fouls the cups, but as there are exceptions to every rule, I would recommend a richer soil, at all events for the offsets, in the coming season. The *Carnation* and *Picotee* layers may be taken off and potted without delay, using the compost as directed last week. Many seedlings have missed blooming, and if not convenient to let them stand over the winter in their present situation in consequence of the large spaces in the beds from which the single ones have been removed, it will be advisable to prepare another bed of suitable compost, and carefully remove the seedlings with balls of soil, and plant them in regular rows. Here they may stand the winter, and will bloom profusely next season.

COLD PITS.

The sooner the potting of bulbs for forcing is accomplished the better, more especially imported bulbs. The chief aim should be to have the roots well established before growth commences, otherwise it is impossible to produce an early and a strong bloom. Most of the failures we meet with are chargeable to the omission of this most important point, and the fault has not unfrequently been charged, most unjustly, on the roots. A soil composed principally of a mellow loam with the addition of old cow manure and leaf soil, and a sprinkling of sharp sand and fine charcoal dust, will be found excellent material. Secure good drainage, and put the bulb high, three parts above the level of the rim, taking care that the soil is in a mellow state, neither wet nor dry. Shake the pot slightly in order to prevent the bulb settling too low, but do not by any means press the soil. They succeed by far the best in a cold frame, and it is most desirable that they should receive no moisture beyond that which the soil contains, until the pot is somewhat filled with roots. Those who have not a frame may plunge the pots in cinder ashes in some sheltered spot, taking care to raise them above the ground level for fear of water lodging. Be careful that there is a free passage for the rain, and let them be covered with 6 inches of some mellow material, such as old tan, old leaf soil, sawdust (if not too new), or ashes. This depth is necessary to keep out sharp frost. Bulbs put in water-glasses should be kept in a somewhat dark

place until pretty well rooted, suffering the bulbs to barely touch the water at first.—W. KEANE.

DOINGS OF THE LAST WEEK.

KITCHEN GARDEN.

The anticipated showers came greatly to our relief, freshening up everything out of doors. Parks and pastures are still rather brown, but lawns are in some cases quite green, and in others greenish yellow, with the green making headway. In some places the rain has commenced to fill the pools and ponds, and the water, dirty as it is, will be a great relief in many neighbourhoods, where even the household washing in working men's homes was becoming a serious matter, when every bucketful of water had to be daily paid for. All vegetables feel the genial influence of the showers and the cooler atmosphere. To make amends for the loss of Peas, *Scarlet Runners* and *Dwarf Kidney Beans* are exceedingly fine. Perhaps in the case of cottagers and amateurs, and many of the former read these pages, we had better modify a little what we said last week about pulling off all pods too forward for use, especially as respects the *Scarlet Runners*. A market gardener who largely supplies several towns in this district called the other day, and said that *Scarlet Runner Beans* must be scarce and expensive next season. He never had poorer crops; the extreme dryness had scorched up everything. Even *Scarlet Runners* were very poor, though generally they used to yield abundantly. All but the first early Cauliflower had been nowhere, and even now his winter vegetables looked miserable; the young Cabbages, too, were eaten up with caterpillars, and whole clouds of fly lodged in the hearts and destroyed the vitality of the plants. It will be well, therefore, for small growers who have healthy *Scarlet Runners*, to allow some of the oldest pods near the base to ripen their seed. We fear that in many cases the plants are too far gone, and so eaten up with red spider as to be of little avail, and in that case it is of little use retaining them where a row of good winter Greens could take their place. Owing partly to the stiff character of the ground, our *Scarlet Runners* were never better, being tall, and covered with pods. If these frosty mornings continue, we shall most likely suspend over them a rough straw band—that is, a band with a good deal of straw left outside of the band, so as to arrest free radiation upwards. By such means, even after frequent frosts, we have gathered in November. Where cottagers cannot save a few seeds, owing to the plants being too much exhausted, if the roots are still fresh and fleshy they might save themselves buying seed at a high price, by lifting the roots, and packing them in dry earth in any place where frost did not reach them. A good many would begin to push in April, and when planted out would produce rather earlier than plants raised from seed. Some also say that such roots yield more profusely than plants raised from seed; but we cannot say so from our own experience, having generally found plants from seed the most productive.

Caterpillars, Fly, and Slugs.—There are many complaints that, besides being smaller than usual, all the Cabbage and Broccoli tribes are eaten-up by these depredators. One gentleman told us the other day, that the leaves of his Broccoli and Cauliflower were quite riddled with holes, and that after much perseverance in picking off caterpillars. For several days we had a goodly company of white butterflies, which are so partial to depositing their eggs on the Cabbage tribe. When we had little boys in the garden we used to send them to hunt down the butterflies, which was as good as play to the boys at first. We did not adopt any such plan this year, and we have been troubled with scarcely any caterpillars as yet. The butterfly is rather a fine gentleman or lady, and is rather particular as to scent. We attribute our comparative freedom from insects to the scent from a little soot and half-burned charred refuse scattered over the ground on some parts of the garden; this we think, deterred the butterfly from alighting.

As a whole, we have never known a season in which so few slugs and snails were to be seen. The dryness taught them to keep down where they could find moisture. Now we see traces of them, though not at all plentiful. All the soft molluscs are deterred from crawling on rough surfaces, such as fresh-stirred ground, and more especially if a little rough ashes and lime are strewn over it. Fresh lime will kill them and worms when it reaches them, though sometimes a big snail will escape by quickly getting rid of its outside skin. They may be easily collected on handfuls of fresh brewers' grains, to which they are very partial, or beneath young Cabbage leaves slightly

heated and greased on the under side before laying them down, and going round with a lantern at night or early in the morning. There is a hard slug or snail with a yellowish-brown belly that nothing seems to kill. There is nothing for it but catching or trapping in some of the above ways. Fortunately it is fond of marching on hard substances, such as a firm, smooth gravel walk, and thus numbers may be picked up in a damp morning. Though injurious, we never found them so voracious as the softer common slug.

As yet grubs have not troubled us much this season. Perhaps we have had to replace a score of Cabbage plants, after finding the grub at the roots. All the slug tribe have as yet been scarce, though we hear they are plentiful in some places. We found to-day clusters of bluish fly in the hearts of the young fresh-planted Cabbages. We shall syringe them forcibly with clear lime and soot water. A little water will go a great way, and a double dose will generally settle them. A little soot and quicklime in powder scattered over them will do the same, but sometimes that is rather too much for young plants, and less or more it daubs up the leaves, and in bright weather is apt to scald them at times. The syringing with the caustic water is the cleanest mode, and does the young plants least harm. We have noticed a few Cauliflower plants with the heads just forming thus attacked with fly, and in their case we would use clear soot water, as drizzling or even fresh lime water might affect the colour, if not the tenderness of the head.

We tied up our earliest Celery, and ere long will earth-up the first bed, the tying having already commenced the blanching. We are much later than usual, owing to dryness and the scarcity of water; but as yet we see no sign of a plant bolting, which we attribute greatly to the shade given by green branches, &c.

FRUIT DEPARTMENT.

Flies and a few wasps make holes in the best fruit in the open air, but are pretty well excluded from that under glass by gauze netting over the openings. It is well, therefore, to commence gathering early Apples, Peaches, and Plums before they are dead ripe, and before they drop. They eat all the more juicy if gathered a short time before they are thoroughly ripe. All dropped fruit is less or more injured by falling. The best Plums, Peaches, and Nectarines that drop are good enough for cooking purpose, but a Plum for the dessert will look all the better with the stalk attached to the fruit, and the bloom uninjured. Even an Apple can scarcely fall without leaving a mark or bruise, which, if not seen before, is sure to be seen when peeled. We have several times gone over *Red Quarrendens* and *Kerry Pippins*, both good Apples in their way. A little practice enables the gatherer to pick the ripest as if by instinct. To keep the stalk to Plums a sharp knife or small scissors are necessary. The stalk is just as essential to completeness as the stalk is to the Melon. A fine fruit of the latter looks incomplete without it.

We gathered in the last days of August a few Peaches from the open wall. We fear we shall not be able to keep the fruit in the orchard houses so late as usual. With double glass roofs much might be done in the way of retarding, as the extreme heat would be kept out, and yet the light allowed to pass to give perfection in colouring. Owing to the heat and dryness our fruit are ripening faster than we wished them to do.

Strawberries.—The plants turned out of pots have yielded some good gatherings, but nothing to what they would have done in an ordinary season, or if we could have watered them freely. There are plenty of runners coming now. All the earliest-potted Strawberry plants, having pretty well filled the pots with a mass of roots, have received manure waterings, and lately each pot has received over the soil a pinch of soot held between the thumb and two fingers. It is best to err on the safe side, and not give too much, as two dressings are better than one large one. These will be washed down with frequent waterings for a month, and if by rain now and then all the better. The scent of the soot keeps many intruders away, and few manures are so successful in imparting a rich green to the foliage. Perfecting growth should be the main object this month, and ripening the buds the chief object at the end of September and the beginning of October. All runners from plants in pots have been cut off, as in such a case they are ex-hausters rather than feeders, and were we to allow them to act as feeders we should so far neutralise our object, as they would continue growth and promote luxuriance when we wish the early ripening of the plant, to make it fruitful early in the spring. Our object should be by healthy foliage first to secure a strong, well-shaped bud, and then to mature it early. With-

out this attention, huge plants in September and October may be less productive of fruit in March and April than plants of half their size but thoroughly matured.

Have our readers noticed that though last year Beech mast was abundant, there is very little to be found this season? On the other hand we never witnessed such crops of acorns, hips, haws, horse chestnuts, &c. These are generally regarded as the signs of a severe winter. We do not contemplate any scarcity of food, but we fear in many country districts there will be a great scarcity of the means of procuring it, owing to the scarcity of employment, &c., the ensuing winter, partly owing to the shortness of straw, and chiefly to the general failure of the Turnip crop, as good fields are too much the exception. Food, though cheap, may be very scarce if there be little or no wages forthcoming to purchase it. If in such a season some of our chemical coadjutors could hit on a simple plan for removing the astringency from chestnuts and acorns, they would confer a public advantage. Fowls, pheasants, pigs, deer, &c., thrive well on acorns, notwithstanding the astringency. People in time may become used to anything. The other day we saw a man with a branch of Sloes well loaded with fruit, and he was eating them with as great avidity as most of our readers would have partaken of the finest Gooseberries.

ORNAMENTAL DEPARTMENT.

We have had several sharp hoar frosts in the last week of August, much earlier than we have been in the habit of witnessing. Owing to comparative dryness these did little harm. After a heavy shower in the evening of the 2nd inst. the sky became very bright, and the frost early in the morning told more owing to the flowering plants in beds being wet. A second time our Coleus beds were browned a little, but not so much as they were by the one day of excessive heat. A number of leaves of Perilla were also slightly browned, and a few flowers of gorgeous masses of different-coloured Geraniums had their petals a little bleached. Broad-petalled blooms, as Rubens and Donald Beaton, suffered more than the smaller-petalled Nosegays. What struck us as a little singular is, that the lighter flowers, as Rubens, suffered more than dark ones of the Tom Thumb and Punch varieties. Towards the afternoon the traces of the bleaching by frost were nearly gone. Five lines of Iresine Herbstii were not in the least touched. We have as yet no break in the general gorgeousness, with the exception of some beds of Verbenas, that all at once almost entirely stopped blooming owing to the dryness. We hope they will come on again after the showers, as they form part of a group where their colour is required to make the composition complete. Similar beds rather disappointed us in the autumn last year. If we had the prospect of a like scarcity of water we should be inclined to do without Verbenas in beds forming part of a group. The mulching did not save them from the drought, as we believe it saved the moisture-loving Calceolarias. No such precautions need be considered by those who can apply water as needed.

Picking faded flowers and petals from beds is a matter of great importance, especially in showery autumns. Wishing to have everything neat, this work has taken up much time. It is not only that these faded blooms look badly when dry, and most wretched when wet, but every shower, if at all continuous, is apt to send the dirty colour of the exhausted flowers over the blooms and leaves that are still perfect, thus greatly disfiguring them. Our beds have needed little picking this year, the blooms having stood so well, and the showers having been so gentle as not to disturb them. A number of the oldest required removing so as to give room to the younger and fresher blooms. A correspondent has told us that in his, and some neighbouring places, the foliage of the varieties of Scarlet Geraniums, kept getting yellow and dying off. We have had nothing of the sort here as yet, with all the dryness and scarcity of water. We never saw the foliage better, and we like to see good growth as well as plenty of bloom.

Took the opportunity of the showers to well roll the walks and lawns. This will help to keep them smooth and firm for the season. When a lawn is well rolled, it is comparatively easy to keep it neat, either with the machine or scythe. We lately saw a young lady working a 12-inch machine, and she did it with as much gracefulness as if she were handling a croquet mallet.

Proceeded with potting Cinerarias, Primulas, Geraniums, Ferns, and stove plants; with re-arranging corridors, the conservatory, &c.; and with propagating for next summer, as lately more fully detailed.

Comparing Notes.—There has been great diversity of opinion expressed as to the Golden Feverfew. We have been both disappointed and delighted with it. We believe the secret of being delighted consists chiefly in using young seedlings instead of cuttings or older plants left or divided. We have used it round Coleus, and as the plants were from cuttings and old plants divided, they have disappointed us, as they have not grown so strongly and regularly as we wished. We have edged a group of six beds round a centre, which was edged with white-leaved Cineraria. The six beds are in pairs, though crossed alike, and these, though the season has been dry, form a fine edging about 7 inches wide, of a rich soft greenish yellow. The plants were raised from seed sown in March under glass, pricked out first, and then planted out when small. We may have to take cuttings, but in our opinion they are not to be compared to seedlings for regular vigorous growth. These six beds have each inside of the Feverfew a blue ring of a dwarf blue Lobelia. One pair of beds particularly pleases us by their soft beauty. These are edged and ringed as stated, then the beds are filled with Mangles's Variegated Geranium, and that is again mixed with the light blue free-growing Lobelia gracilis. This small blue mingling with small pink flowers, and carpeted with the variegated leaves, and edged as stated, is to our eye very beautiful. The soft greenish yellow edging made all complete.—R. F.

TRADE CATALOGUES RECEIVED.

- James Carter & Co., 237 and 238, High Holborn, London, W.C.—*List of Dutch Bulbs, Fruit Trees, Roses, &c., for 1870.*
 B. S. Williams, Victoria and Paradise Nurseries, Upper Holloway, London, N.—*General Bulb Catalogue, Catalogue of Fruit Trees, Roses, &c.*
 Hooper & Co., Central Avenue, Covent Garden Market, London, W.C.—*General Catalogue for 1870, containing Descriptive Lists of Dutch Bulbs, &c.*
 Robert Parker, Exotic Nursery, Tooting, Surrey.—*Catalogue of Hyacinths and other Bulbous Roots.*
 Wood & Co., 3, St. Nicholas Street, Worcester.—*Catalogue of Dutch Flowering Bulbs.*

TO CORRESPONDENTS.

* * * We request that no one will write privately to any of the correspondents of the "Journal of Horticulture, Cottage Gardener, and Country Gentleman." By doing so they are subjected to unjustifiable trouble and expense. All communications should therefore be addressed *solely to The Editors of the Journal of Horticulture, &c., 171, Fleet Street, London, E.C.*

DRYING FLOWERS (Miss Ashton).—But few flowers retain their full colour when dried. To retain it as far as possible place them between folds of blotting paper, press very gently, and change the blotting paper for fresh every morning and evening.

WHITE EXCRESCENCE ON BEECH TREE (Stafford).—It is a parasitic fungus, and all such parasites are injurious in some degree. Scrape it off, and paint the trunk and branches with a mixture of clay and sulphur in water.

FOUNTAIN (A. Robinson).—That figured was executed in America, but many of our English fountains could supply one similar.

ALANTHUS GLANDULOSA (F. D.).—So far from being rare it is one of the commonest of trees. Seedlings two years old may be bought by the hundred at about 1½d. a-piece, and plants from 1 to 2 feet high for about 4s. per dozen. We answered your question last week.

STOVE-HEATING A SMALL GREENHOUSE (R. A.).—An iron stove 12 to 14 inches square would be ample to suit your purpose. So many makers advertise stoves lined with fire-brick, that we cannot with impartiality recommend one. If there is any difficulty in your neighbourhood, buy a stove 1 foot square, and a fire-box 8 inches square to stand in the middle. (H. B.)—Nothing will be so good for your little house as a small iron stove with the pipe through the roof. If you can use gas, a small gas stove either of iron or terra cotta would do, a small gas-pipe from the top into the open air being provided.

REMOVING PINE-APPLE SUCKERS (A Constant Reader).—The true Ripley Queen Pine Apple has a broad pip. A number of suckers will take strength from the fruit. We would have removed a number of yours earlier. If the fruit is swelling it would do as much harm as good to remove the suckers now. When the fruit is cut we would earth them up and take four fruit from a stool.

ROSES ON THE MANETTI STOCK (Seyhor).—Manetti stocks are propagated from cuttings about 10 inches long, of firm wood, leaving a couple of leaves. The cuttings should be inserted in the earth now. They should be planted about 5 inches deep, and be trodden in firmly. The distances at the Dorset Nurseries, Blandford, are 6 inches from plant to plant, and 18 inches or 2 feet from row to row. It is not too late to bud Roses on the Manetti stock. If the slice will peel, and the stock run, you will succeed. Do not land on the wood of this year, but on the main stock. Bud as low as you can. Scrape away the earth, as the covered bark of the stock will often run, when the exposed part will not do so. Now with regard to the 13½ feet of sloping bank 6 feet in width, with a 15-inch wall, I should plant against the wall those noble yellow Roses on

short stocks, so as to utilise the wall—namely, Gloire de Dijon, Maréchal Niel, Cline Forester, Triomphe de Reunes, Solfaterre, and Lamarque. I should allow each Rose ample room to ramble in single file, espalier fashion—that is, a single branch on each side of the stock. As you have some good Briar Roses, I should use them, by planting them at the top of the slope 6 feet apart, and the Manetti-stocked Roses 3 feet apart each way, planting the strongest growers next in rank to the standards, and the dwarfier plants lowest. I do not understand whether the wall is at the top of the slope or at the bottom, but in any case I should use it for the Tea-scented yellow Noisettes, which are, for beauty and performance, the best in the Rose kingdom. My garden now groans with these fine yellow Roses. Lamarque and Solfaterre are not here, I regret to say. As to the description of Roses, there can be no question that Hybrid Perpetuals, with Baron Gonsella, Marguerite Bounet, and Souvenir de Malmaison, Bourbons, and beautiful Mrs. Bosquet, China, are the best to have. In my opinion, Teas, Tea-scented yellow Noisettes, and Hybrid Perpetuals, are the Roses to have. If you wish variegated Roses, you must have summer Roses—namely, (Gillet Parfait, Tricolore de Flandre, Madeline, called also Emmeline, and Double-margined Hipp. They are all beautiful. The first is tender, but the best; and the other two are vigorous and hardy.—W. F. KADLYFFE.

BURNING SULPHUR TO DESTROY RED SPIDER (E. H.).—If you had consulted the repeated statements made in our pages you would never have burned sulphur in your vinery to get rid of red spider or anything else. Burning sulphur in a confined place is likely to kill everything that is green. It makes little or no impression on well-ripened hard wood of deciduous trees when the leaves are gone; but even if the leaves are fallen it will injure wood that is not well ripened. Sulphur fumes, so distasteful to red spider and other insects, cannot be safely liberated at a temperature higher than from 100 to 170° among growing plants. We are not surprised that the foliage and Grapes have suffered. If, as you say, the wood was ripening at the base, we should not be so much afraid of next year's crop, more especially if you encourage some offset shoots with young leaves on them, to maintain the root-action, reducing first and then removing them in the autumn. This will help to remedy the great error.

LILIUM LANCEFOLIUM REBREM AFTER FLOWERING (R. H. F.).—Let the soil be kept moist, but by no means give so much water as when the plants are growing and flowering, and when the stalks decay turn the plants out of the pots and remove the old loose soil, but no more than can be done without injury to the roots; remove the small offsets and repot, using a compost of two parts turfy loam, one part peat, and one part of old cow dung or leaf soil, with a free admixture of sand. Drain the pots, and pot low enough to afford room for a top-dressing of rich compost in spring. If the crowns of the bulbs are just covered with soil at the potting that is sufficient. Set the pots in a cool house, and keep the soil moderately moist. They will winter safely in a cold pit or orchard house, the pots being plunged so as to protect the roots from frost.

SELECTING VEGETABLES AND FRUIT FOR EXHIBITION (Tadn.).—Of the Vegetables you mention—viz., Potatoes, Peas, Runner Beans, Celery, Cabbages, Cauliflowers, Carrots, Turnips, Maize, and Globe Artichokes, we should select the first eight as being the most useful, and to such the prize should be given rather than to novelty, the specimens being well cultivated. Peaches, Pears, Plums, Apples, and Melons would, we consider, be a better collection of five fruits (Pines and Grapes being excluded), than your showing Nectarines in place of the Plums; but you must look closely to the wording of the schedule, for we think the prize will be offered for five out-door fruit, and in that case you must exclude the Melon, and show Nectarines instead. Show a Melon if you can without infringing the rules.

SPIDEA JAPONICA AND S. PALMATA TREATMENT (Glasscutter).—The best way to grow them is to plant them out in an open situation, and in a soil well drained and enriched with cow dung or leaf soil. If the situation be shaded from the direct midday sun all the better. Water freely when growing and flowering. The Meadow Sweets delight in a moist soil. If you wish to grow the plants in pots, plunge them now in a situation such as we have described, and let them remain until November, when you may place them on a shelf in a light airy greenhouse. The plants will flower early in spring, and are among the finest of forced plants. After flowering continue them under glass for a time, and then plant them out in the open ground. In autumn take them up, pot them, and place them in a cold frame until required for forcing, or in the greenhouse, where they will come on more slowly than in a forcing house, but will flower as well if not better. They are hardy herbaceous plants and ought to be in every garden. If left in the open ground give a mulching of leaf soil to the plants every autumn, when the foliage decays, and before severe weather sets in.

VINERY BUILDING OVER A VINE (Inquirer).—We have no doubt that raising a light house against your warm Vine wall would be of great service, even though you put it up in March and remove it in October. As you use no artificial heat the Vine would not suffer in winter, for you protect the roots. All moveable houses are expensive—that is, if made in sashes, and not merely glazed in grooves to be easily removed. The cheapest houses are fixtures, with large squares and strong sash bars instead of rafters. In such a case, without any fire in winter, there is little danger of glass breaking if not glazed too tightly, and such a cold house is useful for many things in winter.

SUPERIOR HELIOTROPES (Hatfield).—For "prettiness of flower, compactness of habit, and constitution," Beauty of the Boudoir; but if you want one for winter-flowering, Monsieur Hamatre is excellent.

TAKING UP GLADIOLUS BULBS AND POTTING (Idem).—There is no doubt that many of the evils which beset this splendid flower are due to the drying the bulbs during the season of rest. We do not think it wise to take up the bulbs, dry them to the extent they frequently are, and then plant in wet soil. We like your plan best—namely, taking up the bulbs soon after ripening, potting them, plunging and covering them in ashes, and then setting them on shelves in a cold house. There is but one objection, and that is, unless you can ward off heavy rains the soil is rendered too wet to be of benefit to the plants, but that can be guarded against by a waterproof covering during wet weather. The situation selected for plunging should be dry and well drained. With us the Gladiolus grows and blooms finely in the shrubbery borders, and with no more care than the shrubs and other plants, weeds being kept down, and the surface occasionally stirred. It is not nearly so tender as many suppose.

HEATING A PIT (E. W. F.).—Sometime ago Mr. Fish described how to make the most of such a pit as yours, 5 feet high in front, 7 feet high at back, and 5½ feet in width, with a pathway along the back, and a brick-on-bed wall to separate the path from the bed. In his case the pit was sunk below the ground level nearly 3 feet, a matter of importance so far as heating was concerned, as 3-inch pipes would be about as effectual as 4-inch pipes if the walls were exposed to the atmosphere. With the mode of giving air in front and also at the back we are satisfied, only for early forcing it would have been as well if the ventilators had been lower down, so that the air given in front should go over the pipes before passing into the house. Now, we have repeatedly stated that the cheapest mode of heating such a pit or house for propagating Cucumbers, Melons, &c., would be to take a strong tube made of brick-on-bed, and strong covering through the chamber & under the bed, and having openings into the passage to let up top heat. We could command any amount of moisture from such a tube by giving plenty of moisture round it, not on it. Hot water, however, is more easily managed and requires less care. For winter Cucumbers in such a house, you would require two 4-inch pipes for bottom heat in the chamber & two for top heat near the ventilators in front. If you were satisfied with spring forcing, 3-inch pipes would do. The price of the pipes would be proportional, the larger ones about 2s. 6d. a-yard, with more for elbows and turns. A small saddle-back or conical boiler costing from £3 to £4 would suit your purpose. We decline to recommend tradesmen, as we believe all who advertise in our columns are to be trusted, and that disappointments and misconceptions are more owing to the whims and changes of opinions of the employer, than to any wish to take advantage in the case of the employed. Hence, when a plan is adopted and a fair estimate given, it is to the benefit of all parties to adhere to the plan and keep out all extras, which, in general, are anything but an advantage to either party. Now, to some of the specific questions:—First, if you are resolved to have a chamber beneath your bed, with pipes for bottom heat, then strong slate will be the best covering, the pipes running through the chamber and having the means of giving bottom heat and top heat as you like, by having the top of the boiler lower than the lowest pipe in the chamber. If you resolve on such a chamber, it will be all the better to have a few slits from the passage at the bottom of the chamber to admit air, as you want of this is a fertile source of the pipes for bottom heat not acting. Above the slate you should have at least a 2-foot space for drainage and soil, say from 4 to 6 inches of the former, which should consist of rough rubble. We would have upright drain-pipes in each light, and by pouring down water among the rubble we could have moist bottom heat, and moist top heat at will. The latter could be also obtained by evaporating-pans placed on the top pipes. Whatever space you leave between the earth-bed and the trellis for the Cucumbers, the trellis should be at least 15 inches from the glass. We have no fault to find with heated chambers provided with the air-slits before referred to; but we would never think of one in such a pit as yours. Having fixed on the position of our pipes, by taking into account the trellis, depth of soil, and depth of covering of pipes, we would concrete and roughly cement the bottom of the smaller enclosed pit for soil. On that we would place our pipes, and pack between them and over them as closely as possible to the depth of 4 inches, with brick-bats, clinkers, stones, flints, &c., finishing at the top with a layer of clean-washed gravel stones, say from 5 and not more than 6 inches from the pipes. On this place the soil, which can always be removed easily without at all disarranging the covering. A common drain-tile set upwards in the back or front of the pit, the bottom and just a little above the concrete will enable you to give a moist bottom heat at will; we have had such in use many years, and never found anything cheaper or better. When we renew our beds, we brush the soil as clean as possible out from the small clean gravel. We think this mode rather more effectual and far cheaper than chambering for all narrow pits. One question remains—"Would it add much to the expense to have the pit divided, and the heating apparatus so arranged as to heat one or both halves as desired?" Yes, it would add to the expense. The cheapest mode of heating such a 24-foot pit would be to place the boiler at one end, and let the bottom and top heat go right through. We have done so with some pits much larger than yours, and we divide each pit as we like with moveable wooden partitions, easily lifted out and in, and we keep a high temperature and a comparatively low one, merely by giving a little or abundance of air. There is always much expense connected with valves, &c. The cheapest way you could regulate your pit, so as to have one half well heated, and the other heated only a little, or none at all, would be to place the boiler in the centre, take the flow-pipe to a receiving-box, and to that have two pipes for a flow both ways, one of which you could wholly or partially plug up as you like. You would thus escape the expense and trouble of valves, which are very good in their way, but the best of them are apt to go wrong.

LAWN WEEDY (T. H. T.).—We should weed the lawn at once, cutting up the weeds by the roots—that is, as far down as you can, removing as much of the root as possible, and this we would continue to do all the autumn, and early in March we would well rake the lawn with an iron rake, and then apply to it a good dressing of very rotten manure; early in April we would rake it well, sow some grass seeds, and roll well.

MRS. POLLOCK GERANIUM NOT THRIVING (Idem).—Your plants are probably in a dry situation and are suffering from that. We should pot them at once in a rich turfy loam, and place them in a light airy part of the greenhouse, where, we have no doubt, they will recover.

TREATMENT OF BAMBOO AFTER GROWTH (Idem).—We should leave the plant entire, and in spring after growth commences we would cut away all the injured and dead parts. Mulch round the plant in winter with decayed leaves. The leaf and flower sent us appear to belong to some herbaceous Phlox. If so, the plant should be grown in an open situation in good, light, loamy soil. The Willow must have had its stem or roots injured, the bark probably gnawed off the stem, perhaps by water rats.

WIRING A FRUIT WALL (X. Sibmuth).—The most suitable wire is that known as No. 10. For Peach, Plum, and similar fruit trees the wires should be 6 inches apart. For the Peach and Apricot we like them in every course of brick, or 3½ inches apart; but for Apples and Pears 10 inches will be a good distance. The Morello Cherry requires them the same distance as the Apricot. We have our wires 3½ inches apart, and make that do for all kinds of fruit trees. They ought not to be more than three-quarters of an inch from the wall, the nearer the better. The directing eyes may be 6 feet apart, but we prefer them half that, or as near as we can get them to suit the openings in the wall for driving

them in. You will need a piece of iron at one end to fasten the wires to and at the other end you will need a similar piece with holes at the proper distances, through which bolts can pass, and by means of those you can tighten the wires like a fiddle string. The screws are kept by every ironmonger, or he will procure them for you, and all that is necessary for fixing. The wires should be stretched in a horizontal direction; it is the cheapest and best plan.

VIOLA CORNUTA DYING (*J. F. C.*).—We think the plants are old and exhausted by early flowering, and the heat and drought of the past summer. We advise you to take up the whole, raise fresh plants from cuttings or seed, and plant afresh after digging the ground well and working in a liberal quantity of manure or leaf soil. Trees, by keeping the ground dry and exhausting it with their roots, would be injurious. Had you given the ground a few good soakings of water, and a top-dressing of short manure, which the foliage would have hidden, we think all would have been right.

NECTARINES WITHERING BEFORE RIPENING (*Idem*).—The tree has most likely been too dry at the roots, and the fruit has consequently shrivelled; or it may have been infested with red spider. We think more copious supplies of water and mulching over the roots would have prevented the mishap.

FILLING AND MANAGING A FERN CASE (*T. J. H.*).—In an early number we shall treat of the subject fully.

GLOXINIAS AFTER BLOWING (*E. H.*).—After flowering the plants ought to have a position near the glass, in a house with a temperature of from 50° to 55° at night until the growth is matured, as it will be when the leaves and stems are withered. Give no water from the present time until the leaves show signs of flagging, then give a moderate supply; continue this treatment until October, then withhold water altogether, but set the pots on a floor whence a moisture will pass to the soil but not to the extent of making it wet. The tubers winter all the better if kept rather moist, for when kept just-dry through the winter they are apt to become farinaceous, and decay when moistened in the spring. In winter they will be safe if kept in a house with a temperature of 45°.

PLANTS FOR WINTER AND EARLY SPRING FLOWERING (*Idem*).—We have the following in our greenhouse, and they flower at the time you wish:—*Acaecia armata*, *Drummondii*, *grandis*, *oleifolia elegans*, and *longiora* magnificæ, the last two in our opinion the best of all the *Acaecias*; *Benaria splendens*, *Bornia Drummondii*, *Bouvardia Humboldtii*, *B. Leicantia compacta*, *Coronilla plena*; *Correns Brillant*, *Harris*, and *speciosa major*; *Cyclamen persicum*, *Cypripedium venustum*, *Cytisus Atleamus* and *racemosus*, *Lacunia gratissima*, *Magnolia lutea*, *Monachatum ensiferum*, *Primulas*, *Camelias*, *Viols*; *Euphorbia Hyacinthiflora*, *Lady Alice Peel*, *Lady Penance*, *Rubella*, *The Bride*, and *Viscountess Hill*; and *Erica colorata*, *melanthera*, *hyemalis*, and *autumnalis*. The forcing house will give you *Azaleas*, and a variety of hardy shrubs and plants, as *Lilacs*, *Double-flowering Peaches*, *Cherry*, and *Plum*, *Prunus sinensis flore-plena*, *Dentzia gracilis*, *Roses*, *Dicentra spectabilis*, *Spirea japonica*, *Lily of the Valley*, and *Bulbs of Hyacinths*, *Narcissus*, *Tulips*, and *Crocuses*.

MILDEW ON ROSES (*Idem*).—Soot is a good remedy, but not always a cure for mildew. We have not found anything better than frequent forcible syringing of the trees overhead, and to keep the roots well supplied with water, and dust the parts infested with flowers of sulphur whilst the leaves are wet. An old stocking is as good as anything for distributing the sulphur.

PLANTING STRAWBERRIES (*M. G.*).—The best time to plant Strawberries is in summer, as good well-rooted runners as can be secured. The rooting ought to be facilitated by laying them and taking off the runners or string beyond. Well trench and manure the ground, mixing the manure with the soil. Plant the Strawberries in rows 2 feet apart and 1 foot from each other in the row. After they have fruited once take out every alternate plant, so that they will be 2 feet apart every way. Water well after planting, and during dry weather.

ANNUALS FOR PRESENT SOWING (*Idem*).—*Candytuft*, crimson, lilac, and white; *Clarkia pulchella* and *Clarkia pulchella alba*, *Collinsia bicolor* and *grandiflora*, *Erysimum Peroffskianum*, *Eschscholtzia californica*, *Limnanthes Douglasii*, *Lupinus nanus*, *Nemophila insignis*, *Saponaria calabrica*, *Silene pendula* and *alba*, and *Virginian Stock*, red and white.

ASHLEAF KIDNEY POTATOES FOR SEED (*Idem*).—Take them no if you have not already done so, and place them in a dry shed, if on shelves all the better, so that they may have air all round. When they are thoroughly dried place them in a cool dry cellar or other place secure from frost, but the colder the better, so long as they are safe from frost.

HYACINTHS AND TULIPS FOR PLANTING IN A ROSE BORDER (*H. C.*).—We think you will only be disappointed if you plant Hyacinths and Tulips in the same border for simultaneous blooming. We should confine ourselves to one of the two, having a line of red, white, and blue Hyacinths, placing the blue next the walk, the red at the back, and the white between the two. We have no doubt that they would have a pretty effect if a double line of each were planted with bulbs 9 inches apart, and the rows half that distance from each other. If you had Tulips which would flower later we would advise a line of *Bien C-este*, then *La Candeur*, and *Tournefort* at the back. But why have either of those? the *Roses* are sufficiently beautiful without them. We like to grow one thing well, and if we had our choice would have *Roses* only on the same ground. Besides, to do the *Roses* justice they ought to have a good mulching of manure in autumn, and it ought to remain over the winter, removing the loose manure in spring, and pointing the rest in with a fork.

ALFRED COLUMB ROSE (*Idem*).—It is more vigorous on the Manetti stock than on the Brier, though on the latter it does well when the soil is a strong loam. It requires plenty of manure, and abundant watering and mulching in dry weather. It is a splendid Rose.

LIQUID MANURE (*A Constant Reader*).—The stable, cowhouse, and other sewage without diluting with water may be put on to the soil previous to digging for any kitchen-garden crop, and so it may to Asparagus and Rhubarb whilst growing. For flowering plants it should be diluted with at least five times its bulk of water.

GRUBS (*John Knight*).—The grubs eating off your Cabbage plants just below the surface are the larvae of the Daddy-longlegs (*Tipula*). Try taking up the plants and replanting with their roots only just below the surface. It has been stated that it is only the soft succulent collar of the plant that the grubs can bite; the woody part is too hard for them.

NAMES OF PLANTS (*J. T. Sinclair*).—*Senecio saracenicus*; *Stenactis speciosa*; *Atriplex patula*. (*A Fern-grower*).—1, *Scolopendrium vulgare*; 2, *Pteris longifolia*; 3, *Pteris tremula*; 4, Probably *Nephrolepis exaltata*; 5, *Cystopteris fragilis*; 6, *Asplenium farcatum*. (*Lichard Jameson, Gargrave*).—It is a Moss, *Dryum nodulatum*. (*Somerset*).—1, *Euonymus japonicus aureo-variegatus*; 2, We do not undertake to name florists' flowers; 3, *Senecio elegans purpurea flore-plena*. Give the *Euonymus* greenhouse-treatment. (*G. P.*).—1, *Adiantum athiopicum* (A. assimile); 2, A. *capillus-Veneris*, deeply cut variety. (*M. B.*).—*Nephrolepis tuberosa*; *Pteris*, apparently *P. quadriaurita*. We do not recognise the *Adiantum*, which appears much too large in the pinnae to be referred to *capillus-Veneris*, which otherwise it much resembles. (*Collingham, R. W.*).—2, *Nephrolepis tuberosa*; 3, *Doodia lunulata*.

POULTRY, BEE, AND PIGEON CHRONICLE.

POULTRY AND BIRDS.

It appears to me that I must say a word on behalf of farmers' wives who have to keep poultry as a source of profit, and who sometimes get considerably snubbed by their husbands, who grudge the destruction of a few rods of corn or clover, and who evidently don't reason on the matter, and don't or won't understand either the habits or the profits of poultry.

A farmer will readily turn a large flock of sheep to trample on and drag down a fine field of clover or grass, but he would be much annoyed to see half an acre eaten by his wife's poultry. He will give his pigs barley and beans by the sack, but objects to the poultry helping themselves to their kernels. By-and-by I will tell him which pay best for their food, for I am sure he has never entered into the question. Let us now consider the habits of poultry. Take my own as an instance, for some three hundred of them have free access to all my fields (no fences to obstruct them) from the early morn to dewy eve.

As soon as the fowl-house door is opened they receive their morning meal of barley; they then at once betake themselves to the fields—for what? Observe them. That wonderful eye of theirs examines everywhere, and, quick as thought, they appropriate every fly, slug, worm, or insect on every blade of grass or clover. This is their occupation during the whole day, except when at rest or when grazing.—for poultry graze equally as do sheep or cattle,—and it is essential that a piece of pasture should be near the fowl-house, otherwise they will, and must, appropriate your young cabbage, turnip, or mangold plants. They must also have free access to water.

What a mistake we make when we cage up poultry, and deprive them of their natural food—green food and insects, with some grain. They are first-class judges of weather. They know by instinct (where does instinct end and reason begin?) when and where their food—insects, worms, &c., is to be most readily found. They watch for every load of green tares or green beans brought home to be passed through the chaff-cutter, and they at once set to work upon the myriads of insects that infest almost every crop.

They are the most industrious and economical of creatures—their ready claw and keen eye are ever at work—not a seed of weeds or grass is wasted. In fact, fowls and birds are true farmer's friends, and the farmer can have no idea how many enemies he has (invisible ones to him) in the shape of insects until he devotes his attention to the operations of his poultry. Although he can neither see his enemies nor know of their whereabouts, the fowls and birds at once detect them, as you may see by their eager darts and rapid movements hither and thither.

Watch a company of Ducks toddling along in regular line, for fair play, and they will show you slugs and insects where you never suspected them. In fact, within a week of leaving the shell the juveniles are on the alert for their natural food, the insect tribe. I could write a small volume on the value of birds, for it is only by watching their habits and good work that the farmer can realise how many enemies he has, and how many friends there are ready to seek for and destroy these enemies.

It is a well-admitted fact by all my labourers that my best and thickest crops are in immediate proximity to the fowl-house, commencing at only 10 yards distance. Yes, but see how they are scratching up the seed corn, and what a mess they make. Well, I have seen them at work between the rows of young wheat (and I only put in a bushel per acre at 9 inches from row to row), and I find in nine cases out of ten that they are in search of insects, and that they do find them. Gardeners who are sensitively particular about the appearance of their gardens, and hate fowls, see, however, what takes place:—An intelligent chemist took to a garden where insects had long and

undisturbed away, and devoured everything. He was fond of poultry, and understood their habits, therefore he gave them free access to his garden; they cleared off the enemy, and he had plenty of everything. No doubt there are times when you would protect your fruit, or your shallow-sown seeds. In my case I sometimes employ a boy for a fortnight immediately after drilling close to the poultry-house, but even when I have not done so, I have scarcely been inconvenienced if the grain was properly deposited by the drill. The hen-coops and broods of chickens are always placed on a patch of grass edging the wheat or barley fields; and if, when the crops are ripe, they help themselves to a few sheaves, I know they are good customers for they must be fed like sheep, or pigs, or cattle; and they always sell for double the price per pound, although they cost less to produce. Partridges are great friends to farmers, although they don't always believe it. There is no surer sign of imperfect tillage than when you hear of birds and game getting out the seed. What I call imperfect tillage is ploughing the land and then merely scratching the surface with light wooden harrows, so that the seeds are close to the surface, and under them are unbroken furrow slices—long, hard lumps of undivided and unbroken earth, in the case of strong soils almost as tough and impenetrable as weather boarding. In my case I always use heavy iron harrows and deep steeled teeth that cut the furrow-slices into mould, or sometimes entwine with the cultivator barrow before drilling, and generally the surface has been well aerified before ploughing, so that the seed is not only properly deposited, but where it grows the young fibres find mould below to work in.

For want of this proper tillage I have seen great losses; the fine fibres cannot work into the great lumps of undivided plough slices which, in stiff clays, are nearly as hard and as whole as weather board. I don't believe that one farmer in ten can tell me what price per pound, live weight, he gets for his poultry, and for his beef and mutton, but I will tell him;—5s. per stone of 8 lbs. is 4½d. per lb. live weight of beef, and nearly about the same for mutton. Now as good poultry always sell for at least 9d. per lb. live weight (I mean wholesale), and as they cost no more per pound to produce than beef or mutton, it follows that we gain one hundred per cent. by poultry, as compared with meat. I have tested this carefully. In fact I know that the difference is greater than this, because I have frequently sold poultry at 14d. and 16d. per lb. live weight, or more than three times the price of meat. When we sell a chicken, the purchaser pays for head, skin, feet, entrails, and all but feathers (which sell for more than the carcase per pound), but when they buy meat, the feet, skin, blood, entrails, &c., are all removed, and called offal; consequently, it requires no conjuror to convince heads of families that poultry is dearer food by one hundred per cent. than meat.

But should poultry be so dear? I answer, Decidedly not, if we, as farmers, did our duty to ourselves, our land, and our country. The demand is evidently in excess of the supply for both poultry and eggs, for we import immense quantities, and, in addition, 500,000,000 of eggs annually! In a former paper I gave you comparative trials of the consumption of barley by a hen and a pig, much in favour of the hen. Of course, your poultry-breeder must understand the business, as must the breeder of other farm creatures. The edge of the fields is the proper place for juveniles, and not cooped up in yards and sheds. Mine are not fancy poultry. I breed from pure stock on each side, say Game, Cochon-China, and Brahma Pootra, all running and mixing together. I like Dorkings, but they won't thrive on our stiff clays. Every two or three years I change the male birds, paying 21s. each for young well-bred ones. We send them to the wholesale salesmen in London, ready plucked.

The hen-houses should have asphalted floors, be kept clean, well-ventilated, and occasionally lime-washed; the slated roof lime-washed in hot weather.

A farmer never grudges barley by the load for his pigs, and cake and corn for his other stock; why should he regret feeding his poultry? We should consider that poultry manure the land the same as any farm animal.

As we are doing away with our trees and fences, there should be plantations on every farm for birds to build in; and we should have plenty of poultry and Partridges—the latter for the farmer's table, if not for his sport. It is well known that many a farmer's wife clothes herself and her numerous family by the proceeds of her poultry. In some cases that I know of one of the farm hands receives a pint of beer when the governor is at market to carry in a sack of barley on the sly for the

nse of the poultry, so as not to shock the farmer's excessive and unreasonable prejudice about the unprofitableness of poultry.

The hen-house floors being asphalted, and swept daily, and having no open farmyard, knee deep in straw, we know nothing about fleas.—J. J. MECH, *Tiptree* (in *Essex Gazette*.)

WAKEFIELD POULTRY SHOW.

TURNER'S pens were used for the feathered stock, placed in two rows on platforms erected for the purpose. Unfortunately a mistake which is of daily occurrence seemed, to some extent, to mar the regular course of events, though we strongly suspect that none but the exhibitors themselves are to blame, a large number of pens of both poultry and Pigeons arriving too late for competition, although the arbitrations were considerably protracted, so as to allow late arrivals a chance.

Game in all classes were moderate in quality, and the pen to which the cup was awarded, fine close-feathered Black Reds. In Game *Dantams* were three classes, and the cup awarded to Black Reds, and in the Variety class the whole of the prizes went to Puckwings. The Black and White were but a poor lot, but there were two pens of Golden-faced of high quality. There were five classes for *Hamburgs*; most of the birds were very fine, and the cup won by a grand pair of Silver-spangles. The *Syriish* were very good; in fact, the first-prize pair were the most promising we have seen this year. The *Dorkings* were large and forward; but the most handsome pen in the large varieties was a pair of Buff *Cochin* chickens, to which the cup for the best section was given. *Jubaults* were a nice display, and the birds in fine feather. The first-prize *Aylesbury Ducks* were not the largest, and won by the great beauty of beak and plumage. In *Renens* the second-prize birds were in full plumage, but the first much larger and correct in marking. The Grey Toulouse *Geese* in the first-prize pen were fit representatives of a Yorkshire farmstead, the girth being more like that of a well-fed pig than a fowl. The rest were Whites of gigantic frame. In the Selling class Spanish were first, Cochins second, and Game third.

The *Pigeon* classes were well filled, the quality being also very fine. Mr. Filton won first in Carriers with a good pair of Blacks, excellent representatives of the high-class Carriers, and the second-prize pen contained a very fine aged hen, but the cock was very short in neck. The *Dragoons* were a nice lot, as also the *Ponters*, in which class Mr. Filton was again in the first rank. *Trumpeters* were good, and the *Barbs* extraordinary, and Mr. Horner won the cup for Pigeons with a well-developed pair of Blacks. In foreign Owls, the Whites in the first-prize pen were very neat in head, and the Blues were also very neat. The first-prize English Owls were good in all points except beaks, which were a little too spindly, although exceedingly good in gullet and frill. Of *Turbits*, the first were Blue, in nice bloom and correct in marking. The first in *Jacobins* were Reds, of high quality and colour, the hood and chain very close. The second were Yellows. The first *Fantails* in style and carriage were all that can be desired, and the second also very good. *Nuns* were neat and well marked. In *Tumblers* the winners were Almonds and Beards, and in the Variety class were some good *Magpies* and *Ice Pigeons*.

There was a good show of *Rabbits*, the Lop-ears measuring well and counting well in points. In bucks Mr. Easton won first and medal for the best Rabbit in the Show with a grand Black and White buck. The second was Blue and White, and the third Yellow and White. In does the first was a Tortoiseshell, not quite so long in ear as the second, but beating in colour, marking, and condition. The Himalayan and the Silver-Greys were shown in good fur, and were a very pretty gathering; and in the Variety class the first and third were excellent Angoras, and the second, a cross between Angora and Lop-ear, was fawn-coloured and of great size. As regards the Rabbits, we believe it is the intention of the Committee to augment the prize list for future shows.

GAME.—Any Variety.—Cockerel.—1, C. Chaloner, Whitwell, Chesterfield. 2, T. Dyson, Halifax. 3, Osborn Bros., Worcester. *Fallow*.—1, C. Chaloner, 2, J. Carlisle, Early. 3, Green & Siffert, Amplebury, Halifax. *he*, Osborn Bros. 4, J. Wade, Bradshaw, Ovensend. *Black-bronzed Red*.—*Chickens*.—Cup, H. Jennings, Allerton. 2, C. Chaloner. 3, J. Wade. *Brown-bronzed Red*.—*Chickens*.—1, J. Carlisle. 2, H. Beadland, Bradford. 3, T. Dyson. *he*, J. Preston. *Duckwings, Blues or Greys*.—1, C. Chaloner. 2, M. Jowett, Clayton. 3, J. Fell, Adwalton. *he*, J. Mason. Any other Variety.—*Chickens*.—1, C. W. Brierley, Middleton. 2, J. Sunderland, Halifax. 3, W. Fell, BAYRAMS. *Game*.—Any Variety.—*Cockerel*.—1, W. F. Entwistle, Westfield, Clackleton. 2, and 3, K. Crosland, Wakefield. *Black-bronzed Red*.—*Chickens*.—Cup, Master J. Crosland, Wakefield. 2 and 3, W. F. Entwistle. 3, F. Steel, Stump Cross, Halifax. *he*, G. Noble, Staincliffe. Any other Variety.—*Chickens*.—1 and 2, T. Dyson. 2, Beltingham & Gill, Burnley. *he*, Miss A. Crosland, Wakefield. 3, W. F. Entwistle. *Black or White*.—*Chickens*.—1, H. Beldon. 2, T. Dyson. 2, J. Walker, Halifax. *he*, Miss M. A. Sandy, Radcliffe, Nottingham. Any other Variety.—*Chickens*.—1, T. C. Harrison, Hull. 2, J. Watts, Birmingham. *HAMBURG*.—*Golden-spangled*.—*Chickens*.—1, H. Beldon. 2, J. Fortune & Co., Norton Banks, Keighley. *Golden-pencilled*.—*Chickens*.—1, H. Beldon. 2, J. Preston, Allerton. 3, J. Sunderland, Halifax. *Silver-spangled*.—*Chickens*.—Cup and 2, H. Beldon. *Silver-pencilled*.—*Chickens*.—1 and 3, H. Beldon. 2, J. Preston. *Black*.—1 and 2, C. Sidgwick, Byddlesdon Hall, Keighley. 3, S. Halliday, Keighley. *SPANISH*.—*Chickens*.—1, C. W. Brierley, Middleton. 2, H. Beldon. 3, E. Brown, Shelfield. *he*, Miss E. Pickard, Thorne, Leeds. *DORKING*.—*Chickens*.—1, T. E. Kell, Wetherby. 2, J. White, Thaby, North-Allerton. *COCHIN-CHINA*.—*Cinnamon or Buff*.—*Chickens*.—Cup, G. Fletcher, Diabry, Manchester. 2, C. Sidgwick, Reddlesdon Hall, Keighley. Any other Variety.—*Chickens*.—1, C. Sidgwick. *BRAMA POOTRA*.—*Chickens*.—1, Mrs. Eurrell, Ipswich. 2, E. Leech, Rochdale. 3, Dr. Holmes, Whitecotes, Chesterfield. *he*, J. Watts. *he*, E. Holland, Chesterfield. *POLAND*.—Any Variety.—*Chickens*.—1 and 3, H. Beldon. 2, H. Bowker, Keighley. *DREKS*.—*Aylesbury*.—1, E. Leech. 2, J. Shillito, Sheffield. 3, W. Stonehouse, Whitby.

he, J. Williams, Wath-upon-Deane. *Boucan*.—1, J. White, Whitley, Netherton. 2, E. Leech. 3, J. Haigh, Huddersfield. *he*, S. H. Stott, Rochdale; Dr. Horsfall, Pontefract. *Any other variety*.—1, C. W. Brierley, Middleton. 2, F. E. Schofield, Morpeth. 3, T. C. Harrison, Hull. *GEESE*.—1, J. White. 2, E. Leech. 3, Rev. G. Hastler, Stillington, York. *he*, S. H. Stott, Rochdale; H. Crossley, Broomfield, Halifax. *TURKEYS*.—1, E. Leech. 2, T. Palethorpe, Carlisle. Pontefract. 3, L. Anson, Forest Hall, Chorley. *SELLING CLASS*.—1, T. C. Harrison, Hull. 2, E. Leech. 3, F. E. Schofield, Stillington. *he*, F. A. Johnson, Wath-upon-Deane; C. W. Brierley. *EXTRA STOCK*.—*he*, Mrs. Wade, Stanley.

PIGEONS.

CARRIERS.—1 and 3, R. Fulton, Deptford. 2, E. Horner, Harewood. *he*, H. Yardley, Birmingham; J. P. White. *DRAGONS*.—1, E. Horner. 2, H. Yardley. 3, F. Graham, Birkenhead. *he*, F. Graham; A. Murgatroyd, Woodroyle, Bradford. *POUTERS*.—1 and 3, R. Fulton. 2, E. Horner. *he*, J. Hawley, Bingley. *TRUMPETERS*.—1, R. Fulton. 2, J. Hawley. 3, E. Horner, Harewood. *BARDS*.—Cup, E. Horner. 2, J. Fielding, jun., Rochdale. 3, R. Fulton. *c*, W. Massey, Spalding. *OWLS*. 1 and 3, J. Fielding, jun. 2, R. Fulton. *he*, Miss Hales, Canterbury. *English*.—1, E. Crossland, Wakefield. 2, G. Horridge, Wakefield. 3, J. Watts. *he*, E. Horner. *TURTLES*.—1, T. C. & F. Newbitt, Epworth. 2, R. Fulton. 3, H. Yardley. *he*, J. Fielding, jun. *c*, E. Horner. *FANTAILS*.—1, J. F. Liversidge, Newark. 2 and 3, E. Horner. *he*, H. Yardley; T. C. & E. Newbitt. *JACOBS*.—1, T. C. & E. Newbitt. 2 and 3, E. Horner. *he*, J. T. Lishman. *SCNS*.—1 and *he*, H. Yardley. 2 and 3, F. Graham. *TRUMPETERS*.—1, E. Horner. 2, R. Fulton. 3, F. Graham, Birkenhead. *he*, J. Fielding, jun. *ANTWERPS*.—1, J. A. Collinson, Halifax. 2, Master J. Crossland. 3, Master C. Crossland. *Equal 3*, E. Horner. *he*, J. Williamson, Wakefield; A. Appleyard, Wakefield. *ANY OTHER VARIETY*.—1, T. C. & E. Newbitt. 2, H. Yardley. 3, A. Murgatroyd. *he*, J. Watts. *SELLING CLASS*.—1, E. Horner. 2, C. Gravit, jun., Thorne. 3, J. Fielding, jun.

RABBITS.

LOP-EARED.—*Back*.—1 and Mohd, A. H. Easton, Hull. 2, Lewin & Johnson. 3, C. Gravit, jun., Thorne. *he*, A. Vaughan; H. Creeke. *Doc*.—1, A. H. Easton. 2, C. Gravit, jun. 3, A. Broughton, Huddersfield. *he*, H. Creeke, Burnley. *HIMALAYAN*.—1, E. S. Rothwell, Rochdale. 2, Master F. W. Horsfall, Pontefract. 3, R. Walfis, Wakefield. *he*, J. R. Jessop, Hull; R. Pearson, Althoys. *SILVER-GREY*.—1 and 3, S. G. Hudson, Hull. 2, E. M. Royds, Greenhill, Rochdale. *he*, A. H. Easton, Hull; E. M. Royds; J. R. Jessop. *ANY OTHER VARIETY*.—1, S. G. Hudson, Huddersfield. 2, E. Vaughan, Hymingham. 3, S. G. Hudson. *he*, W. Hudson, Wakefield; Misses Horsfall, Pontefract.

JUDGES.—Mr. Enoch Hutton, Paisley; Mr. James Dixon, Clayton Bradford; Mr. J. Douglas, Clumber.

STANNINGLEY AND FOLSLEY POULTRY SHOW.

The first annual Show of this Society was held on the 27th of last month. The Committee chiefly consists of working men; but the moral and pecuniary support of the tradesmen and gentry of the neighbourhood have proved the mainstay of the Society. The arrangements were excellent, and there was nothing to mar the pleasure of the visitors, except a little rain which fell at the close of the Show. The entries were good in all the sections, and the quality of the stock very fine. Some of the best of the Yorkshire exhibitors were represented in the poultry classes, and the Pigeons formed a most attractive portion of the Show. The pens for both sections were quite new, on Turner's principle, and were borrowed from the Allerton Society.

The *Cage Birds* were shown in a tent separated from the other departments, and it was crowded to excess during the latter part of the day.

SPANISH.—1, H. Beldon, Bingley. 2, J. Thresh, Bradford. *he*, H. Wilkinson, Earby. *c*, W. Schofield, Gildersome. *COCHINS*.—1, C. Sidgwick, Keighley. 2, H. Beldon. *he*, E. Baxter, Idle. *BEAHM FOOTRAS*.—1, H. Beldon. 2, H. Andrews, Eccleshill. *he*, M. Scott, Ilke. *DORINGS*.—1, T. Briden, Earby. *HAMBURGHS*.—*Silver-spangled*.—1 and 2, H. Beldon. *c*, G. Worsman, Tong. *Golden-spangled*.—1, A. Smith, Northwram. 2, W. Dine, Keighley. *he*, H. Beldon. *Silver-pencilled*.—1 and 2, H. Beldon. *Golden-pencilled*.—1, H. Beldon. 2, W. Clayton, Keighley. *he*, A. Smith, Northwram; Hainsworth and Fyfebank, Farsley; A. W. Bainworth, Farsley. *Black*.—1, C. Sidgwick. 2, H. Beldon. *he*, E. Baxter; 1, W. Hlingworth, Idle. *c*, H. W. Hlingworth. *BANTAMS*.—*Game*.—1 and 2, W. F. Entwistle, Scholes. *he*, A. Smith. *Any other Variety*.—1, H. Beldon. 2, S. & R. Ashton, Mottram. *he*, W. Clayton; T. Dyson, Halifax. *GAME*.—*Cock*.—1, W. F. Entwistle, 2, H. Beaman, Tong. *he*, Harwood & Buckley; E. Ackroyd. *Red*.—1, W. Fell. 2, H. Beldon. *he*, J. Wilson, Calverley. *Any other Colour*.—1, H. Mason, Adwalton. 2, E. Ackroyd, Bradford. *Ducks*.—*Bacon or Aylesbury*.—1, J. Ward, Drighlington. 2, J. Gantt, Paisley. *Any other Variety*.—1, S. & R. Ashton. *ANY OTHER VARIETY*.—1, 2, and Timepiece, H. Beldon.

PIGEONS.

CARRIERS.—1 and 2, E. Horner, Harewood. *he*, S. Smith, Idle. *c*, S. Smith; H. Yardley, Birmingham. *POUTERS*.—1, E. Horner. 2, J. Hawley, Bingley. *he*, J. Hawley; S. Smith; J. T. Lishman, Gillington. *TUMBLERS*.—*Short-faced*.—1 and Timepiece, J. Hawley. 2, E. Horner. *he*, S. Smith; H. Yardley, Birmingham. *OWLS*.—1, E. Horner. 2, J. T. Lishman. *he*, J. Hawley; J. Thresh, Bradford; S. Smith. *TURTLES*.—1, J. T. Lishman. 2, T. C. & E. Newbitt, Epworth. *he*, S. Smith (2). *H*. Yardley; E. Horner (2). *c*, A. Batty, Bramley. *DRAGONS*.—1, H. Yardley. 2, J. T. Lishman. *he*, J. W. Ward, Stanningley; E. Horner. *c*, A. Murgatroyd, Bradford. *ANTWERPS*.—1, J. A. Collinson, Halifax. 2, J. T. Lishman. 3, E. Horner. 4, H. W. Hlingworth. *he*, J. Hawley; H. Yardley; B. Peol, Birkenhead. *JACOBS*.—1 and 2, T. C. & E. Newbitt. *he*, J. Hawley (2); E. Horner. *FANTAILS*.—1, T. C. & E. Newbitt. 2, E. Horner. *he*, J. T. Lishman; H. Yardley. *c*, J. Hawley; E. Horner. *ANY OTHER VARIETY*.—1, E. Horner. 2, J. T. Lishman. *he*, J. Hawley; S. Smith; H. Yardley; A. Murgatroyd.

CAGE BIRDS.

CANARIES.—*Yellow or Marked*.—1 and Cage for best bird in Show, W. Heap, Bradford. 2, T. E. Fosbrooke, Lofthouse. *he*, W. Heap; G. Gott, Calverley. *c*, B. Taneson, Rodley; G. Gott. *Buff and Marked*.—1 and 2, W. Heap. *he*, A. Brook, Swinnow; B. Lawson (2). *c*, G. Gott. *BOTTLED BIRDS*.—1, W. Heap. 2, J. Benn, Upper Workley. *he*, T. E. Fosbrooke. *Parrot or Cuckoo*.—1, W. Gannet, Stanningley. 2, G. Bowling, Stanningley. *he*, W. Heap, Bradford. *he*, W. Heap; J. C. Colson, Stanningley. *FOREIGN BIRDS*.—*Any other Variety*.—1 and 2, W. Heap.

The Judge was Mr. E. Hutton, Paisley.

POULTRY SHOW AT THE CRYSTAL PALACE.—We are informed that negotiations are now pending with the Crystal Palace Company, for a repetition of a London Show this year, and that

it is proposed to be held during the time of the London Cattle Show. Next week we hope to be able to announce it in our usual list of forthcoming Poultry Shows.

FARNWORTH POULTRY SHOW.

The following awards were made in the poultry department at the sixth annual Show of the Farnworth (near Warrington) Agricultural Society held on the 2nd inst. :—

GAME.—*Black-breasted*.—*Chickens*.—1 and Cup, C. Chaloner, Whitwell. 2, J. Halsall, Eccleston. *Brown-breasted*.—*Chickens*.—1, J. Carlisle, Earby. 2, M. A. Forde, Maghull. *Any other variety*.—*Chickens*.—1 and *he*, J. Halsall (Duck-wing). 2, C. Chaloner. *Any colour*.—*Cock*.—1, C. Chaloner. 2, M. A. Forde. *DORINGS*.—*Chickens*.—1, Hon. H. W. Fitzwilliam, Wentworth Woodhouse. 2, H. Pickles, jun., Earby. *SPANISH*.—*Fitzwilliam*.—1, C. W. Brierley, Middleton. 2, H. WOODR, Sheffield. *COCHINS*.—*Cinnamon or Buff*.—*Chickens*.—1 and Cup, W. A. Taylor, Manchester (Buff). 2, Mrs. Burrell, Ipswich (Buff). *W*. W. Ryland, Erdington. *Partridge or any other variety*.—*Chickens*.—1, W. A. Taylor (Partridge). 2, J. Stephens, Walsall. *HAMBURGHS*.—*Golden-pencilled*.—*Chickens*.—1, T. Wrigley, jun., Middleton. 2, H. Pickles, jun. *Golden-spangled*.—*Chickens*.—1, Chaderton & Scholes, Hollinwood. 2, J. Buckley, Ashton-under-Lyne. *Silver-pencilled*.—*Chickens*.—1 and 2, H. Pickles, jun. *Silver-spangled*.—*Chickens*.—1 and Cup, J. Fielding, Newchurch. 2, H. Pickles, jun. *POLANDS*.—*Any Variety*.—*Chickens*.—1 and 2, H. Pickles, jun. (Silver). *PRADMA FOOTRAS*.—*Chickens*.—1 and Cup, Mrs. Burrell. 2, W. A. Taylor. *BANTAMS*.—*Game*.—*Chickens*.—1 and Cup, J. W. Morris. 2 and *he*, W. F. Entwistle, Cleckheaton. *Cock*.—1, J. W. Morris. 2, G. Maples, Wavertree. *he*, W. F. Entwistle (2). *Any Breed*.—*Chickens*.—1, Withheld. 2, S. & R. Ashton, Mottram (Black Bantams). *ANY OTHER VARIETY*.—*Chickens*.—1, Hon. C. W. Fitzwilliam. 2, A. D. Payne, Shrewsbury (Malay). *SELLING CLASS*.—*Chickens*.—1, Withheld. 2, H. Pickles, jun. (Polish). *DUCKS*.—*Bacon*.—1 and Cup, A. Woods, Sutton. 2, F. Grall. *he*, G. Gladstone, jun., Broad Green; T. Wakefield, Golborne. *Aylesbury*.—1, E. Leech. 2 and *he*, M. Scamson, Hartwell, Aylesbury. *Any other variety*.—1, C. W. Brierley. 2, H. B. Smith, Broughton (Shields) *he*, R. Gladstone, jun. (Carolinas and Brown Calls). *GEESE*.—1, E. Leech. 2, Withheld. *TURKEYS*.—1, E. Leech.

JUDGES.—Mr. Richard Teebay, Fulwood, Preston; Mr. Joseph Hindson, Barton House, Everton.

BINGLEY POULTRY SHOW.

The best of the chicken shows of the present season is, undoubtedly, that held at Bingley, under the auspices of the Airedale Agricultural Association. The greater part of the poultry pens were arranged round the sides and part through the centre in single tier, the only drawback being that the Pigeons were placed on the top, which was a great disadvantage for both Judges and the public. Of *Game* fowl there were some good birds in both classes, the cup falling to Black Reds, and the display of Duckings was such as we did not expect to find at this time of year, the colour of both cockerels and pullets being very fine. *Spanish* were but moderate, but the *Dorkings* very large and good in colour, and Mr. Kell won the cup for this section with birds of this variety. *Cochins* and *Beahms* were of high quality. But with the exception of the winners the Golden-spangles were poor. The rest of the *Hamburghs* mustered well. The quality was of high order, although the *Gold-pencils* showed somewhat later than was the case last year. *Polands* were good and were all *Silvers*. All the *Bantams* were good, and the cup awarded to *Game*. In the *Selling Class* *Game* were first, *Spanish* second, and *Polands* third. The *Ducks* were large and good in beak and plumage.

Among the *Pigeons* were some of the best specimens in the kingdom. In *Pouter* cocks many of the birds were out of feather. The first *White*, and the second *Blue*. In *Pouter* hens a capital *Yellow* was first, and won also the cup for the first eight classes. The *Carriers* were well represented in both sexes. The *Almonds* were good throughout, and the first-prize pen nearly perfect. In other *Tumblers*, *Red Mottles* were first, *Bluebeards* second, and *Kites* third. The *Barbs* were very broad in skull and good in eye. In *Owls*, *Whites* were first, and *Blues* second and third. The *Jacobins* were a neat lot, close in *mphod* and chain, and very sound in colour; but the best gathering of this section was the *Fantails*, the carriage and style perfect. In the "Variety class," *Porcelain Swallows* were first, *Reds* second, and *Runts* third. The first in the *Selling* class were *Agates*, and second, *Turbits*.

The heaviest *Rabbits* were 13½ and 13¼ lbs. The length of the ears 22 inches, and the width a little over 5 inches. The first-prize *Lop-car* was a grand *Black* and *White* buck, the second *Grey*, and the third *Tortoiseshell*. The class for varieties was good in all respects, the first a perfect *Himalayan*, the second *Silver-Grey*, and the third *Angora*, and many capital specimens had to be content with commendation only.

GAME.—*Black and other Reds*.—Cap, J. Preston. 2, J. Carlisle, Earby. 3, W. Bentley. *c*, J. Irid, Bingley. *Any other Variety*.—1, M. Jowett, Clayton. 2, J. Carlisle. 3, G. Ambler, Queensbury, Halifax. *he*, J. Fortune, Newton Banks. *c*, T. Briggs, Bingley. *SPANISH*.—1, H. Beldon, Bingley. 2, J. Newton, Silsden. 3, E. Brown, Sheffield. *c*, J. I. Booth, Silsden; J. Thresh, Bradford. *DORING*.—1, 2, and Cup, T. E. Kell, Wetherby; 3, J. White, Northallerton. *he*, T. Briden, Earby. *COCHINS*.—1, 2, and 3, C. Sidgwick, Rydlesden Hall, Keighley. *HAMBURGH*.—1, E. Leech. 2, W. Hurry, Sheffield. 3, W. Whitley, Sheffield. *HAMBURGH*.—*Gold-spangled*.—1 and Cup, W. Driver, Keighley. 2, T. Wray, Wolverhampton. 3, T. Dean, Keighley. *he*, C. Halstead, Bingley. *Silver-spangled*.—1 and 2, H. Beldon. 3, G. & J. Duckworth, Church, Accrington. *c*, W. Bairstow, Bingley. *Black*.—1 and 3, C. Sidgwick. 2, H. Beldon. *he*, J. Cockerott, Hawkehead, Keighley. *Gold-pencilled*.—1 and 3, H. Beldon. 2, J. Wilkinson, Earby. *he*, E. Clayton, Morton Banks; J. Smith, Gilstead; T. King, Bachelshwaite, Bingley. *Silver-pencilled*.—1 and Cup, H. Beldon. 2, E. Louchford, Bingley. 3, T. Longbottom, Bingley. *ANY OTHER VARIETY*.—EXCEPT *BANTAMS*.—1 and 3, H. Beldon. 2, H. Bowker, Hill Top, Keighley. *BANTAMS*.—*Game*.—1, 3, and Cup, W. F. Entwistle, Cleckheaton. 2, G. Noble, Stainchiff, Dewsbury. *he*, Harewood & Buckley, Accrington. *Any other*

variety.—1, H. Beldon, 2, T. C. Harrison, Hull, 3, J. Riley, Hawksworth, *hc*, W. H. Robinson, Long Lee, Kegbly; H. Beldon. **SELLING CLASS**.—1, W. Johnson, Idle, 2, J. J. Booth, 3, J. Swire, Morton, c, J. Berry, Silsden. **Ducks**.—*Aylesbury*.—1, E. Leech, 2, G. Andrews, Newark. *Bouen*.—1, E. Leech, 2, J. J. Booth, 3, C. Sidgwick. *hc*, J. Clayton, Kegbly. *Any variety*.—*Ducklings*.—1, J. J. Booth, 2, J. Watts, Birmingham, 3, H. Cockshott, Morton.

PIGEONS.

POUTER.—*Cock*.—1, J. Hawley, 2, R. Fulton, Deptford, 3, W. Harvey, Sheffield. *hc*, J. Hawley; J. Walker, Newark; R. Fulton (2); E. Horner, Harewood. *Hen*.—1, 3, and Cup, R. Fulton, 2, E. Horner. *hc*, J. Hawley (2); R. Fulton, 3, E. Horner. *Cock*.—1, R. Fulton, 2, H. Yardley, 3, E. Horner. *hc*, R. Fulton, 2, E. Horner. *Hen*.—1 and 2, R. Fulton, 3, E. Horner. *hc*, H. Yardley; R. Fulton. **TUMBLERS**.—*Almond*.—1, R. Fulton, 2, E. Horner, 3, J. Fielding, jun., Rochdale, *hc*, W. Harvey, Sheffield. *Any other variety*.—1, T. H. Hawley, 2, J. Fielding, jun., 3, R. Fulton. *hc*, J. Hawley; R. Fulton, c, W. Harvey. **BARDS**.—1, E. Horner, 2, J. Fielding, jun., 3, R. Fulton. *hc*, W. Harvey; R. Fulton. **OWLS**.—1, J. Fielding, jun., 2, R. Fulton, 3, W. Harvey. *hc*, F. Moore; J. Fielding, jun. **JACOBIUS**.—1, R. Fulton, 2 and 3, E. Horner. *hc*, W. Harvey; E. Horner. **TRUMPETERS**.—1 and 2, J. Hawley, 3, W. Harvey. **FANTAILS**.—1 and Cup, W. Harvey, 2, J. F. Loversidge, 3, E. Horner. *hc*, J. Walker, Newark; C. Sugden, Wilsden; F. Graham, Birkenhead. **TREBITS**.—1, J. Fielding, jun., 2, R. Fulton, 3, Clayton & Birstow, Gillingham, Bradford, *hc*, E. Horner; J. T. Lishman, Gillingham, Bradford. **DRAGONS**.—1, F. Graham, 2, H. Yardley, 3, J. Watts. *hc*, J. Hawley; Clayton & Birstow; W. Harvey; W. Stanhope, Eccleshill; E. Horner. **ANTWERPS**.—1, J. Collinson, Halifax, 2, E. Horner, 3, J. T. Lishman. *hc*, H. Yardley; W. Harvey, Birkenshaw. *Any other variety*.—1, J. T. Lishman, 2 and *hc*, E. Horner, 3, S. Smith, Idle, c, W. Harvey; H. Yardley. **SELLING CLASS**.—1, J. Fielding, jun., 2 and *hc*, Clayton & Birstow, 3, J. Watts, c, J. Hawley; W. Hingworth; W. Stanhope; E. Horner.

RABBITS.—*Heariest*.—1, E. Vaughan, Birmingham, 2, A. H. Easton, Hull, 3, J. Quick, St. John's Wood. *Lop-eared*.—1, A. H. Easton, 2 and *hc*, C. King, St. John's Wood, London, 3, Lewin & Johnson, Kettering, c, W. Scarbrook, St. John's Wood. *Any other variety*.—1, A. L. Rawstraw, Haslingden, 2, E. F. M. Roys, Greenhill, Kochdale, 3, M. Driver, Morton. *hc*, E. Vaughan; A. H. Easton; S. G. Hudson (2); J. R. Jessop (2).

The Judge was Mr. E. Hutton, Pudsey, Leeds.

SOUTH-WEST AGRICULTURAL SOCIETY'S
POULTRY SHOW.

This was held at Limerick on August 30th.

DORKINGS.—1 and *hc*, Mrs. Warburton, 2, S. Mowbray, SPANISH.—1, S. Mowbray, 2, J. C. Cooper, *hc*, E. G. Poer, BRAHMAS.—1 and c, J. C. Cooper, 2, Mrs. Warburton. *hc*, Hon. J. Massey; Mrs. Warburton. **GAME**.—1, 2, and *hc*, E. G. Poer. **ANY OTHER VARIETY**.—1, 2, and *hc*, J. C. Cooper, *hc*, E. G. Poer; Hon. J. Massey. **DUCKS**.—1, Hon. J. Massey, 2, J. C. Cooper, *hc*, J. C. Cooper; W. Lysrecht; S. Mowbray. **DUCKINGS**.—1, Hon. J. Massey, 2, Mrs. Warburton. **GEES**.—1, S. Mowbray, 2, J. C. Cooper, Extra 2, Mrs. Warburton. *hc*, Hon. J. Massey; J. C. Cooper; Mrs. Warburton. **TURKEYS**.—Cup and 2, J. C. Cooper, *hc*, S. Mowbray. **HAMBURGERS**.—1 and 2, Hon. J. Massey.

JUDGE.—Mr. C. F. Staunton, Clondalkin.

PIGEONS AT WHITWORTH AND ROCHDALE
POULTRY SHOW.

The Pigeons at Rochdale were one of the most attractive features of the Exhibition, and as would be seen by the prize list published last week, not only were the entries unusually large for an agricultural meeting, but the choicest specimens from many of the best collections in the kingdom were brought together, thanks to the enterprise and judicious management of Messrs. Roys and Fielding—two most enthusiastic local fanciers, to whom, we believe, the success of this department of the Show is due.

With an entry of 288 pairs of Pigeons the services of two well-known Judges were secured, the classes being divided between them with the exception of the special prizes, which were awarded conjointly, the first prize in each class only, of course, competing. This arrangement is very objectionable, for we think each Judge should also award the special prizes in the portion entrusted to him.

Pouters had four classes. In those for single cocks and hens respectively, Red or Yellow, the latter colour took the lead, Mr. Fulton winning with very fine birds. The principal prizes in the other classes were awarded to capital Blues, with the exception of the third prize being taken by a good White hen.

Carriers had the like number of classes, with a good competition. Mr. Wiltshire's first-prize Black cock was particularly good in beak and wattle. The single Black hens formed a fine class, Mr. Fulton taking all the prizes, and also the sectional cup, with his first-prize hen. All were remarkably good specimens, shown in the finest possible manner. Several excellent hens received notice. The Duns were not so numerous, hot good in quality.

Short-faced *Tumblers* were well represented, having three classes—namely, Almonds, Balds or Beards, and Any other variety. Curiously enough in every class the southern fanciers had to give place to local exhibitors. Mr. Fielding's splendid pair of Almonds also gained the sectional cup. The same exhibitor held his usual place in Balds and Beards. In the Any other variety class Mr. Minnett, jun., took first with a magnificent pair of Black Mottles, Mr. Hawley having second with an equally fine pair of Red Mottles, the best we have seen for some time.

Owls, foreign and English, had each a class, which was well filled.

Bards were divided into Blacks and Any other colour, and were a show of themselves; indeed, it is very seldom we have seen such a competition. Captain Heaton took the first prize, as well as the sectional cup and the second prize, for Blacks with splendid birds, evenly matched, and shown in admirable condition, while Mr. J. Firth, jun., was third with a remarkably good pen; the cock is one of

the best in the kingdom, but requires a more developed hen to match him. We understand £25 were offered for this cock and declined.

Turbits, Red or Yellow, competed together, while *Turbits*, Any other colour, also had a class. Mr. Fielding took both first prizes with small, fine, well-marked birds.

Nuns were a poor lot, only one prize being awarded; want of merit, trimming, and disease being the causes of the prizes being withheld.

Jacobus were good. In the class for Yellows Mr. Horner was first, also taking the sectional cup with a splendid pen. For Any other colour Mr. Horner also took the first prize with excellent Reds, and particularly fine Blacks were second and third. Mr. E. E. M. Roys also exhibited, not for competition, his crack pair of Black Jacobus, winners of cups and prizes at most of the leading shows.

Through the considerate interest of Mr. Roys, Messrs. Otley, of Birmingham, offered a silver medal for the best pair of Antwerps, which Mr. Horner obtained with very smart Dons. The class contained many good birds, the cocks being generally of great merit, but in most cases imperfectly or indifferently matched in some respect.

Fantails and *Dragons* were average classes. *Trumpeters* were good. Mr. Horner was first with Dark Mottles in a very keen competition with Mr. Haansbergen's Light Mottles; the latter were unusually good in points, but rather too light in colour. The third position was taken by good Whites. There was nothing particularly new or worthy of especial remark in "Any other variety" class.

HOW LONG ARE QUEENS AND WORKERS
IN THEIR CELLS?

WITH the "Handy-Book of Bees" I am not acquainted, but from the extracts given, and the reviews of the work which appeared in several newspapers, I have formed a very high idea of the author, both as an elegant writer and a practical apiarist. I am, however, rather surprised that the evidence adduced by Mr. Woodbury has not convinced him that he is undoubtedly mistaken when he says that "perfect queens are produced on the fourteenth day after eggs have been put into royal cells." Instances, I do not deny, may have occurred, but none have come under my observation, and I am not aware of Mr. Pettigrew having given any proof of the allegation beyond a mere *ipse dixit*. I would, therefore, like him to say that he has actually witnessed what he states, and that his conclusions have been arrived at, not by inference, but from observations correctly made.

It is well known that the evolution of queens and bees is much influenced by temperature and the supplies without, but the circumstance of hatching being hastened or retarded in particular cases does not affect the general law. The commonly received opinion, that twenty-one days are required for the egg of the hen to hatch, is not proved to be erroneous by large hens' eggs needing to remain under the hen twenty-three or twenty-four days. Exceptions prove the rule. To my mind the experiments conducted by Mr. Woodbury satisfactorily prove his position. He tells us that the colony employed by him was "populous," and that the period selected for applying his test was "the height of a very favourable season." All the conditions requisite for determining the point at issue appear to have been present, and the result showed that sixteen days were required for the evolution of a queen from an egg.

The general rule I believe is this, that if the queen regnant is removed from her hive, a young queen as successor will make her appearance on the fourteenth day; but this circumstance does not prove that fourteen days and no more have elapsed since the hour that the egg from which she proceeds was deposited. Bees when their queen is removed do not immediately discover their loss, but they are seldom so long in finding out the calamity that has befallen them as to be under the necessity of selecting for royal honours the larvæ that proceed from the most recently-laid eggs. The fact that open cells containing larvæ are almost always to be seen for a day or two after the royal cells are sealed, shows that they are relatively younger.

The precise age, however, of enclosed queens, and the time required for their evolution, has been ascertained on ocular evidence, and as I have had considerable experience with regard to the matter, I shall relate some experiments that were made a few years ago which bear on the questions at issue between Mr. Pettigrew and Mr. Woodbury. In 1862 I lodged a swarm in the "mirror hive," which is described in the "Naturalist's Library." On August 20th eggs for the first time were seen to be laid. On the 26th the cells were sealed. On September 7th the young bees had left their cells, and the entry made in my note-book of that date, and which I copy verbatim, is "Bees hatched-out in about eighteen days." Again, on the

15th of July, 1863, I lodged a second cast in a small glass uncomb. On the 22nd the young queen was impregnated. On the 25th numbers of eggs were laid, and on the 27th I removed her from the hive. The bees selected a grub for a queen from the earlier-laid eggs. It was sealed August 2nd, and a young queen emanated on the 10th. On the 16th every young bee had left its cell save three, of which no record has been taken whether they were abortive or ultimately hatched out. I may also mention that in the same year (1863) I removed the queen from a Huber hive, that a young queen emanated on the thirteenth day after her removal, and that every common bee had vacated its cell before the nineteenth.

It is unnecessary to multiply proofs, but I can give them if needed. Meanwhile I shall only add that it is my firm conviction, founded on personal experience, that the views advanced by Mr. Woodbury in opposition to those of Mr. Pettigrew are correct.—R. S.

OUR LETTER BOX.

HARD PROJECTING LEG-SCALES (P. A. M.).—It is comparatively a new disorder, and is very prevalent among poultry. We have it among ours, but it is chiefly confined to Cochins and to the oldest birds. It has also shown itself this year on the legs of a Chinese Pheasant. We are trying experiments, but we have discovered no remedy.

CROSSING HONDANS AND DORINGS (R. H. F.).—The Hondan would not be the bird you require; it is a non-sitter, and we always protest against crossing between those and sitters. It is against all reason. We can easily name a cross that will suit you in all respects but one, that is the size of the eggs. You will not in any of the sitting breeds get larger eggs than you do from the Dorking. We advise you to cross between the Dorking and Brahma Pouter if you want a good hardy fowl that will lay and sit well, rear its young without trouble, and make a capital bird at table. We are never friendly to crosses, but we think this is the best we know.

CHICKENS WITH NOSTRIL DISCHARGE (W. B. E.).—Your Hamburgs are suffering from cold, which will, if neglected, turn to roup. If only part of them are affected remove them from the others. Wash their nostrils with cold water and vinegar. Give each bird two pills of camphor each the size of a pea. Feed them twice per day for a time on bread and ale. Discontinue the sharps and potatoes. Use Ealy's pills.

BRAHMA COCK MOULTING (J. A. C.).—Brahma cocks of the age you name are often a long time getting their feathers, and we do not think the bird you mention will be in full plumage before the end of September or beginning of October. He may, however, be fit to exhibit, although not quite moulted, as he will in all probability be shown against birds of his own age. It will be a good thing if his sickle feathers never come back. Feed him well on ground oats, give him bread soaked in milk, and let him have plenty of green food, lettuce above all.

DOUBLE NAIL (A. K. C.).—This on a Dorking cockerel's toe is no doubt a disadvantage, but could only prejudice success where the competition between two birds was so close the judges had to look to some such accident to enable them to decide, otherwise it would not disqualify the bird.

YOUNG TURKEYS DYING (F. I. C.).—We advise you to remove all the healthy birds to some other place; it is always a risk and a mistake to keep healthy and diseased birds together. You do not say on what you feed. From your description of the crops of your birds we should think there was something wrong in their diet. Even if they roost too thickly that would not account for it; that would produce the swelled heads, which you seem to have overcome. In all cases where food remains in the crop pour warm water down the throats freely, afterwards give each a table-spoonful of castor oil. Give two pills of camphor each the size of a garden pea. Feed only on bread and ale, ground oats mixed with milk, and having onion-tops chopped fine with the ground oats. This treatment must be continued till they are well. It would be beneficial if you have a convenient place, such as an old barn, if you were to shut up the invalids. They would require large sods with plenty of growing grass and mould to be given to them daily, as well as the food we have recommended.

WHITWORTH AND ROCHDALE POULTRY SHOW.—Mr. S. H. Stott, of Quarry Hill, Rochdale, states that he, and not the Rev. G. Hunster, took the first prize for Grey Geese at this Show. The error is that of the prize list forwarded to us.

KEIGHLEY SHOW (J. G.).—If, as you say, your birds were not exhibited owing to the mistake made by the Secretary, the Committee ought to return you the entrance money.

RATS IN A PIGEON LOFT, AND PROPER FOOD FOR PIGEONS (A Weekly Reader).—Gas tar frequently applied to the runs of rats will cause the rats to leave. They are cleanly animals, and cannot bear the touch of tar. We have got rid of the vermin from a pigsty in this way. The tar once dried is, however, of no use, as it will not stick to the rat's fur. The best plan you could adopt would be to put sheeting of tin on the wall the rats run up, letting a piece of tin stand out at right angles from the wall, projecting, say, half a foot or more; the rats could not get above that. Let not the tin be painted, nor have anything on it to give foothold. As to the best food for Pigeons, a mixture of peas, Indian corn, and barley is excellent. We add barley for the sake of the young birds which their parents are just ceasing to feed. They go about in a starved condition, unable to pick up the peas or Indian corn, so we always have some smaller grain mixed with them. They also readily pick up charlock, which the farmers gladly give away, only take care it does not get into your garden.

FOOD FOR SILVER-GRAY AND ANGORA RABBITS (—).—Clover, Vetches, Dandelion, Carrots, Turnips, &c., with crushed oats, bran, Indian meal boiled into porridge, say once or twice a week. This fattens them. Too much green is objectionable, and avoid cabbage. Oat straw and sweet hay they like, and are good for them. They will not succeed well upon the ground all winter, especially the Angora, being hutch Rabbits. The Silver-Grey may be allowed to run as the wild Rabbit, and many are

turned out with them to improve the fur. If intended to remain outside all winter in hutches these must be made warm and dry, 2 feet above ground, and placed with a south aspect. Avoid all damp air, as this gives them the smulles. To remove them from the hutches to place them upon the ground (but never except it is dry), take hold of the ears with one hand, and place the other hand under the hind part of the Rabbit, so as to prevent the hind legs bracing out the bedding with them. If the hutches are 5 or 6 feet in superficial extent they will not often require any exercise out of them; yet to let them have a frisk upon a lawn when the grass is dry is by no means objectionable. All green food should be given dry, or it tends to give the Rabbit the rot; and in the absence of green food soaked peas are good twice a-week, with a little clean water, especially during hot weather.

UNITING SWARMS (T. M. N.).—The dead bees were all workers, but we cannot tell why they were killed, except that in this mode of uniting more or less fighting often ensues. The best plan is to drive both lots of bees into the same empty hive one after the other, and then induce them into their permanent home by knocking the united cluster out on a cloth and placing their hive over them. It is not absolutely necessary to remove one of the queens, although it is well to do so if the opportunity presents itself. Your syrup appears to have been too thick, but the crystals will not injure the bees. We use three parts sugar to two parts water by weight.

COMMENCING BEE-KEEPING (T. A.).—A stock of bees ought at this season to be readily obtainable for the bare value of the hive and the honey which it may be fairly estimated to contain. Get "Bee-keeping for the Many," which may be had free from this office for five stamps, and select from the hives therein described the one which you think most likely to meet your views. If the bees now belong to a near neighbour many will return to the old spot and be lost, thereby weakening the colony, a result which would be avoided if they were brought from a distance of not less than a mile and a half. We cannot recommend you, as a novice, to attempt transferring the stock to a new hive, but should rather advise your waiting for it to swarm in the usual way.

STEWING VEGETABLE MARROWS.—"E. A. M." recommends the following recipe. Just scald the vegetable. When a little softened cut off one end and scoop out the seeds; fill with chopped meat that has been partly cooked, a little parsley, pepper, and salt; lay them in a saucepan the cut end uppermost, to keep out steam and water; add some good gravy flavoured with tomato, and let them stew gently.

METEOROLOGICAL OBSERVATIONS
In the Suburbs of London for the week ending September 6th.

DATE.	BAROMETER.		THERMOMETER.				Wind.	Rain.
			Air.		Earth.			
	Max.	Min.	Max.	Min.	1 ft.	2 ft.		
Wed. ... 31	30.132	30.013	72	33	60	57	W.	.00
Thurs. ... 1	29.912	29.657	73	45	60	57	S.	.00
Fri. ... 2	29.456	29.412	73	55	60	57	S.	.04
Sat. ... 3	29.883	29.377	69	32	60	57	N.W.	.00
Sun. ... 4	29.320	29.539	72	62	53	57	S.W.	.00
Mon. ... 5	29.618	29.307	67	52	60	57	S.	.42
Tue. ... 6	29.471	29.373	67	46	60	57	S.	.16
Mean..	29.770	29.574	70.43	45.00	59.71	57.00	..	0.62

- 31.—Clear and fine; very fine; clear and very fine.
- 1.—Very fine; very fine; overcast at night.
- 2.—Drizzling rain; cloudy, but fine; clear.
- 3.—Showery; heavy showers; clear and fine.
- 4.—Very fine; exceedingly fine; overcast.
- 5.—Overcast; heavy rain; exceedingly heavy showers.
- 6.—Overcast, damp; showery; clear and fine.

COVENT GARDEN MARKET.—SEPTEMBER 7.

THE market is overstocked with all sorts of fruit, and clearances are only made at low prices.

FRUIT.		s. d.		s. d.	
Apples.....	½ sieve	1 0	2 0	Mulberries.....	lb. 0 9 to 0 0
Cherries.....	lb. 0 6	1 0	0 0	Nectarines.....	doz. 2 0 8 0
Currants.....	½ sieve	2 0	4 0	Oranges.....	½ doz. 0 14 0
Figs.....	doz. 0 6	2 0	0 0	Peaches.....	doz. 1 0 8 0
Filberts.....	lb. 0 9	1 0	0 0	Pears, dessert.....	doz. 1 0 0 0
Cobs.....	lb. 6 9	1 0	0 0	Pine Apples.....	lb. 3 0 6 0
Grapes, Hothouse.....	lb. 2 0	5 0	0 0	Plums.....	½ sieve 1 6 3 0
Lemons.....	½ 100 lb	0 16	0 0	Walnuts.....	bushel 10 0 16 0
Melons.....	each 1 0	4 0	0 0	do.....	½ 100 1 0 2 0

VEGETABLES.		s. d.		s. d.	
Artichokes.....	doz. 0 0	0 0	0 0	Leeks.....	bunch 0 4 0 0
Asparagus.....	½ 100 0 0	0 0	0 0	Lettuce.....	doz. 1 6 3 0
Beans, Kidney.....	½ sieve 4 0	6 0	0 0	Mushrooms.....	potte 3 0 4 0
Broad.....	bushel 0 0	0 0	0 0	Mustard & Cress.....	punnet 0 3 0 0
Beet, Red.....	doz. 2 0	8 0	0 0	Onions.....	bushel 4 0 6 0
Broccoli.....	bundle 0 0	0 0	0 0	Pickling.....	quart 0 4 0 8
Brussels Sprouts.....	½ sieve 0 0	0 0	0 0	Parsley.....	sieve 3 0 0 0
Cabbage.....	doz. 1 0	3 0	0 0	Parsnips.....	doz. 0 9 1 0
Capsicums.....	½ 100 0 0	0 0	0 0	Peas.....	quart 0 0 0 0
Carrots.....	bunch 0 4	0 8	0 0	Potatoes.....	bushel 3 0 5 0
Carthage.....	doz. 2 0	6 0	0 0	Radishes.....	do. 4 0 6 0
Celery.....	bundle 1 6	2 0	0 0	Radishes, doz. bunches	0 0 0 0
Celcworths.....	doz. bunches 8 0	6 0	0 0	Rhubarb.....	bundle 0 0 0 0
Cucumbers.....	each 0 6	1 0	0 0	Savoys.....	doz. 0 0 0 0
pickling.....	doz. 3 0	4 0	0 0	Sea-kale.....	basket 0 0 0 0
Endive.....	doz. 3 0	0 0	0 0	Shallots.....	lb. 0 6 0 0
Fennel.....	bunch 0 3	0 0	0 0	Spinage.....	bushel 3 0 0 0
Garlic.....	lb. 0 8	0 0	0 0	Tomatoes.....	doz. 1 0 1 0
Herbs.....	bunch 0 3	0 0	0 0	Turnips.....	bunch 0 6 0 0
Horse-radish.....	bundle 8 0	6 0	0 0	Vegetable Marrows.....	doz. 2 0 3 0

WEEKLY CALENDAR.

Day of Month	Day of Week	SEPTEMBER 15—21, 1870.	Average Tempera- ture near London.			Rain in last 43 years.		Sun Rises.		Sun Sets.		Moon Rises.		Moon Sets.		Moon's Age.	Clock after Sun.	Day of Year.
			Day.	Night.	Mean.	Days.	m.	h.	m.	h.	m.	h.	m.	h.	Days.	m.	s.	
15	F	Welchpool Horticultural Show.	67.5	45.9	56.7	16	35	af 5	14	af 6	48	af 8	9	af 11	20	4	51	258
16	F	Wellingborough Horticultural Show.	68.4	46.8	57.6	16	34	5	12	6	15	9	after.	21	5	12	259	
17	S		68.0	44.9	56.9	16	38	5	10	6	49	9	17	22	5	33	260	
18	SPN	14 SUNDAY AFTER TRINITY.	68.2	46.5	57.4	19	40	5	7	6	33	10	17	2	☾	5	54	261
19	M		67.3	45.3	56.3	21	42	5	5	6	25	11	11	3	24	6	15	262
20	Tu		68.0	44.0	56.0	20	43	5	2	6	morn.	58	3	25	6	36	263	
21	W	Royal Horticultural Society, Frint, Floral, and General Meeting	66.4	45.6	56.0	24	45	5	0	6	28	0	38	4	26	6	57	264

From observations taken near London during the last forty-three years, the average day temperature of the week is 67.8, and its night temperature 45.6°. The greatest heat was 87°, on the 15th, 1865; and the lowest cold 29°, on the 17th, 1840. The greatest fall of rain was 0.99 inch.

PLANTS FOR BASKETS AND VASES.



EVERYTHING in its place, and a place for everything," is a saying applicable to more things than those for which it was first intended, and even in gardening matters a just application of this rule is not met with in every case. It is with a view to help the inexperienced that I purpose calling attention to the plants suitable for vases and similar positions, as well as to those which are unsuitable for the purpose. I do not

profess to give a complete list of such plants, for many others might be added, and possibly some cultivators may differ with me as regards the merits and demerits of those which I shall name. This I shall be the last to find fault with, as with other treatment from that adopted here the plants may give different results.

The plants which I shall notice are those suitable for growing in vases or baskets out of doors, and I use the term growing in the full sense of the word, and not as implying that the plants may be reared elsewhere, and placed in a vase when they are ornamental, and removed when they are no longer so. This mode of treating vases is, I know, very frequently adopted, and with good results; but, to save trouble and expense, a more economical plan has often to be put in practice by those who have not the means of changing the plants often. I shall therefore confine my remarks to vases or baskets which are expected to support during the whole of the growing season a set of plants which must have a creditable, if not gay, appearance throughout that time. The number of plants capable of fulfilling this requirement is by no means so great as might be expected, still they are varied, and, doubtless, considerable additions may be made. One property all such plants must have is that of supporting a healthy growth in a flowering condition on the smallest quantity of soil that can well be allowed them; for with the exception of water or other liquid, it is seldom that any additional help can be given after they are once put in position. Fragile delicate plants are also to be avoided; for vases are often placed in windy situations; yet hanging plants are indispensable, but they ought to be selected with care. Flowers that will endure wind and sun are also requisite, and when plants are made use of for their foliage they must be of the most robust character. There are some other desirable properties, but they will be explained as the plants possessing them come under notice.

I will now suppose that a series of vases or tazzas on a parapet wall bordering a terrace have to be filled, and very often such vases are better adapted for appearance than for the growth of plants; the Grecian tazza, in particular, being very shallow, especially near the edges, yet a broad brim or edge is expected to be covered with foliage of some kind. Wooden or wire baskets are sometimes deeper, and even some kinds of vases, as the Warwick and Maltese, are tolerably deep, still the extent of outer surface to be partially covered with pendant plants or flowers is such that the space allotted for soil is in no instance in excess

of what is wanted. I have found by experience that the soil ought always to be of the soundest description, and not rendered too light by its containing much partially-decayed matter, even if that be turf itself, for a certain amount of solidity is required which leaf mould and half-decayed turf does not possess. One of the best mixtures I ever succeeded in making for supporting plants in vases for a lengthened time contained a large proportion of mud from a lawn drain, good garden soil and sand being the other ingredients. The "staying" powers of this soil were better than in any I ever tried. Of course sufficient sand was added to make the whole porous. It is usual to supply vase plants with manure water occasionally, but unless it is very clear indeed it tends to sodden and choke up ordinary soils, it is therefore advisable not to be too sparing of the sand added. Drainage, also, is an essential matter, and some vases are without any means of securing this, and care must consequently be taken to guard against the inconveniences attending its absence. A greater proportion of broken stones, brickbats, or crocks ought to be placed at the bottom, and covered with some moss before the soil is put in, so that all superfluous water may drain to the bottom; judgment must likewise be exercised in not giving more water than is necessary to moisten the soil, so that it may accumulate as little as possible at the bottom. This remark, of course, only relates to such vases as have no hole at the bottom by which the water can drain away. The modern vases, however, generally have some provision of the kind, and are as a consequence easily enough managed. In their case a few rough crocks at the bottom, with smaller ones over them, are all that is generally required, and the shape of the vases usually insures all the surplus water draining to the proper outlet.

Assuming these matters to be all well attended to, and each vase about half-filled with earth, I will now proceed to the planting. If summer-flowering or other showy plants are decided on, it is desirable to prepare them beforehand, or to pick from amongst those intended for the flower garden such as are most suitable for the work, taking care to have a few large plants for the centre, with smaller plants for the sides. All should be fully hardened-off before being turned out in exposed quarters. I will now commence with one of the most popular plants for the flower garden, the conservatory, and the vase or basket—the Geranium.

GERANIUMS.—Most of the varieties used in bedding may be planted in vases, excepting, perhaps, the dwarf slow-growing kinds, which ought only to be so used where the intention is to frequently change them; and as the plan is more like exhibiting them in vases than growing them there, I have at the commencement of this paper disavowed it. Therefore I recommend only the strong-growing kinds, of which there is an endless variety, but amongst them some are better fitted for the purpose than others. The Golden Tricolors do not always grow fast enough to meet our requirements in every case when there are only small plants to begin with, and the Silver Tricolors are still more slow of growth, but where great variety is wanted both may be used. A pair of our best-filled vases

at the present time (the beginning of September), have Mrs. Pollock in the centre, and the white-flowering Ivy-leaved round the outside. The latter, by its robust character, makes up for all the shortcomings of Mrs. Pollock, and nothing can well exceed the profusion of its pendant shoots with its glossy green foliage reflecting the pretty white blooms, while in the interior some of its shoots climbing amongst the stems of Mrs. Pollock improve the effect rather than diminish it. In planting such vases, however, select the best Golden Tricolors—that is to say, the largest, with only small plants of the Ivy-leaved Geraniums, as the latter by their more rapid growth soon overtake the former. The crimson-flowered Ivy-leaf is, on the whole, not so useful as the white-flowered, but may, nevertheless, be often used with advantage; and a vase filled in the centre with a pink-flowered Zonal Geranium—for instance, *Christine*—may have an edging of the crimson-flowered Ivy-leaved with perfect propriety, and some we have so treated look well. We employed a stronger grower than *Christine* for the centre, but of the same colour; but I regard the Ivy-leaved Geraniums as the most essential of any for vase decoration, and a good pink-flowered kind is certainly as useful as either the crimson or white. There is one with thick glossy green leaves and a good-sized pink flower that is occasionally met with, but I am not sure whether it has ever been dignified with a distinctive name, still it is a great improvement on the oldest variety of this class, and makes an excellent vase plant, possessing the free growth of the two kinds mentioned with flowers of a bright pink colour. The Golden Ivy-leaf has also pink flowers, but they are less plentifully produced, and on the whole the plant seldom looks so well as the sorts just referred to. There is hardly yellow enough in its foliage to entitle it to the term golden, and in the distance it rather looks diseased than edged with that rich striking hue, but it grows and flowers freely, and many persons like it; an improvement, however, rendering it as bright as Golden Chain is much wanted. I am also constrained to make a similar complaint of the only silver-edged Ivy-leaf I have used for the purpose, *L'Élégante*. It may have more merit as an ornamental-foliaged plant, but its habit with me has been for its shoots to grow over and amongst each other, and not strike out boldly for the edge of the basket or vase; even where they are tempted or constrained to do so they do not bend down in the same graceful way as the flower-iog varieties first mentioned. The leaves seem to want the weight necessary to bend the shoots downwards, and the latter stick out horizontally in anything but a graceful manner. I am sorry for this, for the fine growth and other characteristics of the plant appear to claim for it a high position as a vase plant; but as I regard training, excepting of the very simplest kind, as out of the question here, I am constrained to place this plant lower in the scale of useful ones than I should like.

In weighing the respective merits of ordinary bedding Geraniums, the position of the vase with respect to other things must be taken into consideration. If the vase should be so placed as to have a building of a light colour as a sort of background, then let scarlet, or some other colour approaching it, prevail; but if the background is of foliage, a light-coloured flowering Geranium will be most telling—say pink, blush, flesh-coloured, or white, which colours stand out well against evergreens and similar plants, and should therefore be liberally employed in such places.

I may here remark, that whatever colour is determined on, generally the Zonal Geraniums are better than the Nosegays, especially late in the season. It may be true that at some particular time, for instance the month of August, the Nosegays may present a mass of bloom, which the others fail to do; but the bloom does not stand the long dewy nights and frequent wettings of the latter part of the season. This observation applies to plants in beds as well as to those in vases. I may also observe, that where an edging of Ivy-leaved Geraniums like those recommended is used, upright-growing Zonals may be planted in the centre, instead of those of spreading habit; for instance, an old variety called *Crystal Palace Scarlet* has an upright growth, and most of its flowers likewise point upwards, which is not the case with *Tom Thumb*, neither is it so with *Cybister* and *Stella*, popular Nosegay Geraniums; but where no edging plant is used, then a spreading habit is indispensable. The confinement of the roots of the plant when in a vase checks all robust growth, therefore the most vigorous growers may often be planted without any danger of grossness, and even the rank habit of most of the double varieties may be so much altered by confinement that free-flowering specimens will be produced, and the present season they have done remarkably

well in this position. Madame and Marie Lemoine, Andrew Henderson, *Triomphe*, and others, all gross in habit, have become more free-flowering, and the almost entire absence of rain has, no doubt, tended to make the beauty of the blooms continue longer than would have been the case in a moister season. Their satisfactory flowering this season entitles them to be tried again, for it a certain number of plants of a good double variety present only half the number of blooms that such free flowerers as *Orange Nosegay*, *Indian Yellow*, *Brilliant*, and single varieties of old date exhibit, the fact of their being double will insure them many admirers. Double Geraniums edged with some other plant may be set down as well deserving of notice.

The old-fashioned *Mangles's Variegated* must not be forgotten, for it is well deserving a place, although it does not withstand the wind so well as the stronger varieties of the Ivy-leaved section, neither is its habit so truly pendant. Most of the greenhouse varieties of *Pelargoniums*, as they are commonly called (for I am unwilling to apply that term to the bedding Zonals), are not at all suited for the summer decoration of vases and baskets, with the exception, it may be, of some of the smaller-leaved varieties of the Oak-leaved section, of which the old *Shrubland Pet* might be regarded as the type, but the shortness of its flower-stalk, as well as that of most others, is a drawback to its use for this purpose, except in some special cases. The different varieties of sweet-scented Geraniums are better suited for the mixed border, where a sprig may be cut for every bouquet.—J. ROBSON.

(To be continued.)

DAMSONS.

OBSERVING a few weeks since Mr. Robson's remarks on Crittenden's Damson, I wrote to my friend Mr. Roach Smith, at Stroud, asking him if the sort he gave me a few years since under the name of the Cluster Damson was not the same, and I enclose his reply, which is as follows:—

"My former tenant, the late William Herbert, informed me he noticed for years that in his plantation of fruit trees opposite my house one Damson tree bore constantly, while the others had fruit only once in two or three, or three or four years, and then only sparingly. He then noticed that the habit of the tree was different from that of the old or common kind, being more spreading, while the other grows up tapering and loose. But the grand characteristic is its enormous crops of fruit, failing only once or so in ten or twelve years. It must have been fully twenty-five years ago when Herbert discovered this tree; and the tree could not well have been under fifteen years old, as he said he always made £1 a year by it. But who is Crittenden? Did he not have it (if the same) of Herbert? Herbert had no idea of husbanding the treasure he had by sheer luck got hold of.—C. ROACH SMITH."

Damsons are undoubtedly the first remove from the Sloe, for I perfectly well remember, some sixty or seventy years since, my father raising a large number from seed, thinking to get up a large stock. The trees came into full bearing when I was a youth, and I recollect that they were unfit for sale, for the greater number bore small round fruit, much like Sloes, but with less roughness and acidity. Among Damsons the Prune or Shropshire Damson bears the palm for flavour, and, if Mr. Pearson would tell us about his, I have no doubt that the produce of his trees would rival that of Mr. Crittenden. The Dallymple Damson has the downy leaves of the Prune Damson, but is of stiffer growth; it is Scotch, and very hardy. Here we have the English Damson larger than the Prune or the Cluster, and really good. I have suckers from trees planted by my great grandfather about 1730.

The American Damson was so highly eulogised by the late C. J. Downing some years ago, and I was so taken by his vivid description, that I imported trees from America and planted a hedge 300 or 100 yards long. The trees are about twenty odd years old; the fruit, now nearly ripe, is round, and good in flavour without roughness, but it does not bear so well as the Cluster or the Prune Damson. Another Damson I received from Mr. Varden under a name common in Hertfordshire many years ago, but now not known; this is the "Damascene." It is larger than any other Damson. The Bedfordshire Damson makes its appearance in Covent Garden in October; this is nearly or quite as large as the Damascene. I was much struck with the buteness and goodness of this kind, and I wrote to Leighton Buzzard for a dozen trees. They were sent. Most uncouth suckers they were. This year they are bearing fruit. Two or three are common small Damsons; the others are botanical curiosities, being versions of our wild Plum, some red, some green, but all worthless.

So much for Bedfordshire Damsons. A Damson introduced from Germany some years since is very remarkable. I have named it the Sweet Damson. It is a lump of sugar, and shrivels on the tree, it then eats like a small rich French Plum. Engene Fürst is its German name. It is, however, damsonian in habit. Another variety with downy leaves is peculiar to the valley of the Severn near Gloucester, where it "makes a fortune" for the growers. It is a variety of the Violet Plum, but ripens a fortnight or more after the Early Violet. I have named this the Summer Damson; it is excellent for tarts and puddings, as are all the tribe. Lastly, we have the White Damson, a very old sort. There are several varieties of this; the best among them gives handsome yellow fruit, and is really good. A tree trained to a S.W. wall in my son's garden gives fruit as large as moderate-sized Green Gages, and he says they are as good, having a charming, unkillable, yet agreeable acidity.—THOS. RIVERS.

GERANIUMS AND OTHER BEDDING PLANTS IN 1870.

THE season being far advanced, I send a few notes on bedding plants as grown here, trusting they will be found useful by those who, like myself, have little space for wintering bedding plants, and yet have a great number of beds to fill.

By way of preface, I must state that I do not wait for any particular time after July comes in for putting in cuttings of Geraniums. I take them off as early as possible, as by doing so the beds present a more uniform appearance during the growing season; and should I not have put in sufficient cuttings by the third week of August, I find it an easy matter to secure a great number without spoiling the appearance of the beds. On the other hand, by letting the plants grow at will till August, and putting in the cuttings at once, both the neatness of the beds and the flowers are spoilt. Cuttings inserted in beds out of doors require but little attention, and make bushy plants with plenty of hard wood. Syringing at night is all the care they need, and though they will flag in the bright sunshine, do not shade them, nor give them water.

I will now begin with the different Variegated Geraniums. The first on my list is Luna, a bronze; it is a really splendid bedding plant when used in a bed or mass by itself. By no other Geranium is the same effect produced, and unlike most of the Variegated or Tricolor kinds, it is not necessary to take off the flowers. I do not like it in ribbon borders, except when planted in a double row. Too much cannot be said in praise of this variety; it is a Geranium that can be kept through the winter well, being as hardy, or nearly so, as Tom Thumb. This quality is a great consideration, and though the leaves become nearly green during the dark months, they regain their beautiful colours in spring, or sooner if placed in gentle heat. Luna is also very readily propagated either in autumn or spring. My mode of doing so is to take up the old plants in October, pot them in moderately rich compost, leaving the tops on, and to place them in January or February in an early vinery. As soon as they are fairly growing I take off the tops. Luna is but a moderate grower, but very compact. A few cuttings inserted in thumb-pots in August, kept growing throughout the winter, and potted in 4-inch pots in February, make useful decorative plants for the conservatory. Beauty of Oulton must give way to Luna both for foliage and flowers, but is useful as a pot plant.

Mrs. Pollock, a well-known Golden Tricolor variety, is undoubtedly good, but the flowers should never be allowed to remain, as I consider the beautiful markings of the leaves are lost when the blossoms are preserved. To prove this I ask any of your correspondents who are growing Mrs. Pollock to allow the plants of one bed to flower, to pull the flowers off the other, and to note the difference. This is an excellent bedding plant, of much quicker growth than Luna, and inclined to be loose in habit, though this defect is remedied by taking the long shoots off, and putting them in as cuttings. It requires a little heat and but little water, in fact the less the better, to keep it through the winter. I find autumn-struck cuttings keep better than the old plants, and are less troublesome. Sunset is but a poor bedder, though useful for pot-culture.

Cloth of Gold has done well with me, but I have decided to discard it, and replace it with Crystal Palace Gem. The latter is a decided acquisition, the foliage being good and the flowers and habit better. A bed of it is very striking, the rose-coloured flowers showing it off to perfection. It should be kept rather

dry during the winter, and is apt to become nearly green unless it is in a warm atmosphere.

I now come to a different section—the Silver Variegated, of which Flower of Spring shall be the first noticed. This is really a first-class variety both in respect to its habit, which is unsurpassed, and its flowers, which are fine. It may be classed with Luna for keeping in the winter; it is also readily propagated in spring, and I find cuttings struck then do as well as, or better than, autumn-struck cuttings or old plants. Bijon, which has been useful in its time, has seen its day with me; it has a good silver variegation, but the habit is wretched. Flower of the Day, a good old variety, is still useful, though inferior to Flower of Spring.

Italia Unita is a lovely variety. Too much cannot be said in praise of it. The habit is unique, and the colour of the leaves beautiful; it blooms freely, and the flowers are good. It should be planted rather thickly, so as to make a display at once, for it is a rather slow grower. It is also a good kind for keeping through the winter, either as cuttings or old plants. The old plants, lifted in October, potted in light rich soil, and kept growing steadily during the winter, make a grand show for the conservatory in March or April, and can then be hardened-off and planted-out as usual.

Countess of Warwick is good for pot-culture, but makes too much growth with me to be useful for bedding. Lady Plymouth is still a favourite of mine, though it is difficult to keep it in winter, the autumn-struck cuttings doing best. It is useful for mixing in bouquets, and is very fragrant. Mangles's Variegated, though old, is still unequalled as an edging plant, and its treatment is very simple. In October I lift a few old plants, place them in small pots, and keep them rather dry during the winter; early in the year I place them in an early vinery, they afford abundance of cuttings, and spring-struck cuttings of this variety are better marked than old plants and autumn-struck cuttings. Attention must be paid to pegging it down, otherwise it soon grows out of bounds, being of very free growth.

I now come to the Nosegays, of which Stella stands undoubtedly first as regards its flowers, the trusses of which are enormous, its habit, its foliage, and its hardiness. It is easy of propagation, but this should be done in the autumn. It is so well known that I need say no more respecting it. With respect to Lady Constance Grosvenor, I must wait till another season before I say much of its qualifications, though so far there is nothing to say against it. Lord Palmerston, another well-known variety, though rather loose in its truss, is still worth growing, and is one of the best for pot culture.

Of the Zonals, I will first notice an old variety, and a favourite with me—Ivery's Masterpiece, which I have not seen grown for some years. I consider it very effective in foliage, and the white flower stems with good trusses of light scarlet flowers are very showy. I hope to have a good stock of it by May, having now about a hundred rooted cuttings ready for potting. The wood being very soft, it must be kept rather dry during the winter. Autumn-struck cuttings potted as soon as rooted make useful decorative plants for the conservatory. It is very early-flowering. No manure should be used where it is intended to plant this kind.

Beauty of Calderdale I believe will be the best of its class, but I will wait till another season before I say much about it. Madame Vaucher does well here in light soil. It is one of the first to bloom in spring if kept in small pots; it is, therefore, useful for the greenhouse or conservatory. Mrs. William Paul is an excellent variety for pots, but of much value for bedding. Of Rose Rendster I must say the same. Roi d'Italie is good, but to keep it bushy it should have the tops pinched off early in summer; it is free-blooming, and very effective. William Underwood is good, though inclined to make more wood than flowers. The same holds true of Dr. Lindley and Clipper, each of which is good for pot culture. Christine is still useful; in fact, I have not seen anything to equal it for blooming, though it requires constant attention in picking, as it soon becomes seedy. The cuttings should not be put in later than August, and should be potted as soon as rooted, and have every attention to keep them from damping. Trentham Rose is another good old variety, very free-blooming, of a good colour and good habit. This is a good, useful variety, and requires about the same treatment as Christine in the winter. Tom Thumb, though good, is too well known to need comment. Little David I like; it is swifter than Tom Thumb, as free in blooming, and is readily known by its white eye.

In concluding my remarks on Geraniums, I must say that

with me they are favourites, and it will be some time before they can be surpassed, especially the Bronze, Tricolor, Bicolor, and Silver Variegated, kinds of which the foliage is a show without mentioning the flowers.

I now pass to some other good bedding plants. The first shall be *Lobelia speciosa*, which still holds the sway as a dwarf blue-flowering plant; it comes in flower early, and is the last to go out of bloom. Its treatment is very simple. In October I lift a few plants from self-sown seeds, of which there are plenty in the beds, prick them out in square pans, keep them from frost during winter, and place them in gentle heat; it is then propagated as freely as a weed. This method is preferable to sowing seed in spring.

Calceolaria Aurea floribunda, and Prince of Orange, are both useful and effective plants; the latter is more liable to damp-off in winter than the former, but care should be taken to keep the cuttings dry when put in, shutting them up closely in the day for the first week to prevent their flagging, and giving ventilation at night.

Ageratum mexicanum is also good where there is room for it. A pan of cuttings put in during this month, and kept from frost, will afford plenty of cuttings in spring. The same remark is true of *Gazania splendens*, which still holds a place in my garden, though it closes its blooms in rainy or cloudy weather. *Viola cornuta* Perfection is very fine with me, though my stock is limited; still I hope to have a good quantity of it for next season. So far nothing has approached it in beauty, excepting *Lobelia speciosa*, and even that is not equal to it, the blooms of Perfection being large and of a good colour, it is also very constant in blooming. I consider this plant well named, *Viola lutea grandiflora* has done well here; it is very dwarf, and bears an abundance of yellow flowers. I think a bed of it will look well.

Iresine Lindenii is with me another gem; the colour is splendid, and it withstands the hot, dry weather without flinching. This will prove the best coloured plant grown. *Iresine Herbstii* I have thrown away; it is not to be compared with *I. Lindenii*, though it is useful for pots and baskets. *Dactylis glomerata variegata* is a good edging plant, and is easily propagated, for the old plants can be kept in a very small space in the winter, and in spring can be divided by dozens. It will also stand the winter if left in the ground. *Abutilon Thompsonii* is very showy, and is likely to do well bedded here. *Sedum sempervirens* is a neat, compact plant for small beds or rockeries, but it will be some time before it and *Echeveria metallica* be established as favourites. *Pyrethrum Golden Feather* has only been moderately good with me, but I think it is owing to my treatment of it. I put in cuttings of it in October with the *Calceolarias*, and the consequence is they have nearly all flowered, which spoils it.

Coming now to hardier plants, *Arabis variegata* is a good plant for edgings, but the flowers should be pinched out as soon as seen. *Cerastium tomentosum* is still good, but requires to be divided in spring; if left more than a year without replanting it becomes very rough, and is not like the same plant. *Pentstemon magnificum* is a good hardy blue-flowering plant in a mixed garden or for borders.

I have now given the names and the winter treatment of the bedding plants which succeed well at this place, three miles from Manchester. I have purposely avoided annuals, as I consider them out of place in the flower garden proper, though extremely useful for borders and clumps; still *Saponaria colorata* sown in pans or boxes in spring, pricked out as soon as the plants can be handled, and well hardened-off, is very useful and neat.

In conclusion, I would say there is nothing like striking *Geraniums* early and potting when ready, half a dozen well-established plants being worth a score of weak, sickly cuttings placed in boxes and kept anywhere but in the right place. Speaking from my own practice, cuttings should all be in, at the latest, in August, and potted-off in September. Everything should be well hardened-off by the middle of May at the latest, and then planted out, the hardening off the plants simply meaning the well-being of the flower garden for the summer.—STEPHEN CASTLE, *The Gardens, Bent Hill, Prestwich.*

RED BEET FOR A FLOWER GARDEN.

Mr. GORTO must have made the mistake of not getting the right sort of Beet. I purchased a packet of seed from Messrs. Osborn, of Fullam, sowed it on a gentle hotbed, and pricked

out a hundred plants in a border. The effect has been all that could be wished; every plant has come true to its colour, and has remained about 10 inches high in my rich soil. I have *Coleus*, *Iresine*, *Amaranthus*, and *Perilla* planted out, but Osborn's Select Red Beet has far surpassed them in every respect; in future it will be a regular bedding plant with me. Its effect in a bed with *Centaurea candidissima* is superb.—STIFF SOIL.

BEDDING PLANTS IN THE NORTH OF ENGLAND—LAWN MOWERS.

I SEND you a few notes of how bedding plants have done here this hot summer, as such notes from others are always useful to me.

Of *Geraniums*, Waltham Seedling surpasses anything else among the scarlets, and is all that could be wished. *Christine* is also beautiful in its colour. I have tried Lord Derby, but the caterpillars are too fond of it, and damage it to its destruction. I have likewise tried the Double Tom Thumb, but it does not bloom freely enough, and is not effective in colour. Gold and Bronze *Geraniums* have been much greener than last year; they do better with plenty of moisture. *Gloire de Nancy* is of no use out of doors, even as a centie; it runs to leaf, and the trusses become small. *Verbenas* have succeeded better without water, and were most beautiful when it was hottest. *Lobelia* is a short-lived flower, and if plants are forward enough to bloom in June, they are out of bloom at the end of August. *Calceolarias* have been a failure this year, except where well watered. I think they cannot have too much water. *Iresine Lindenii* looks beautiful when well watered, and edged with Golden Feather *Pyrethrum*, as it is here. *Echeveria metallica* is not effective when mixed with such as the above.

May I add a word about lawn mowers, from a theoretical point of view? It appears obvious that a machine which makes few cuts per yard must necessarily rib the grass more than one which makes many; the only question (which is a practical one) is, whether the ribbing of any particular machine is sufficient to be objectionable. Second, that such a machine must be easier to work, as it does less; the only question is, whether the other is too hard to work when the grass is short. Third, that a machine with many knives must necessarily be able to cut the grass shorter, and by hard work it is able to cut it when long. The conclusion from these considerations is, that the old machines alone can bring a lawn to the highest state of finish, such as is required for croquet, while the new must be a great boon to those who have a large space to keep in order, and where the close-cutting of the old machines would be thrown away. So in a large establishment both may be indispensable, since neither can do satisfactorily the work of the other.—J. F. B., *York.*

METROPOLITAN FLORAL SOCIETY—CHAIRMAN'S FLOWER CASES.

HAVING seen the report of the first show of the Metropolitan Floral Society, I, for one, shall be most happy to aid the Rev. H. H. Dombain in his praiseworthy efforts to encourage the cultivation of the pets of my childhood, supposing that those gems of the old-fashioned country and cottage gardens will be permitted a place in the metropolitan shows. I refer to the spring flowers—Pansies, Ranunculuses, the gay and brilliant Anemones, and the lovely Auriculars. As we hope to have the support of our country cousins in this good work, I must remind them that distance, or fear of their pets being injured in transit or flagging from want of natural provision (water), is now a secondary consideration, for by the introduction of Chapman's patent case flowers may be sent hundreds of miles without being injured. To prove what I say is correct, I, as an amateur of very humble pretensions, sent from this place (Gloucester) to the Worcester-shire Show, held at Kidderminster on the 30th of last month, in one of these patent cases six bunches of flowers, and on their return on Monday morning the 5th inst., finding them in such good preservation, sent through a friend to the Crystal Palace Show on the 6th of this month, where they remained the three days, and look well this morning after having been in the case ten days, and travelled above three hundred miles! I suppose an advertisement of the Society will soon appear. When it does I shall be happy to subscribe my mite, and do all I can to induce others to follow my example; for, depend

upon it, those who spend their leisure hours in the cultivation of flowers will have their minds guided to higher thoughts, and set a good example to all around them.—L. W.

MANDEVILLA SUAVEOLENS HARDY.

LOVERS of this most beautiful and useful plant should more frequently try to grow it out of doors. I believe that with care, and good judgment in selecting a proper position, it will thrive in many parts of England. I have this summer seen it growing at three or four different places that I have visited; but just before I left Lillesden I called upon my friend Mr. Jack, of Battle Abbey, in Sussex, and among the many choice things he showed me was a large plant of the Mandevilla growing against the walls of the old Abbey. It was so luxuriant, and flowering so freely, as to quite surprise me; the foliage was very large and healthy, which is very different from the state in which it is many times found when the plant is under glass; the flowers were fine and white, and the clusters large. If my memory does not deceive me, there were two plants growing against the wall. The larger one was planted about twelve years ago, and it covered many square feet of the old abbey wall; the smaller plant was a seedling raised from the old one, and was planted by Mr. Jack about seven years ago; it, too, was in a perfectly healthy condition, and flowering freely. Both plants, Mr. Jack told me, withstood last winter's frost uninjured without the protecting material that was usually put over the plants. Perhaps they were a little sheltered from the cold and cutting winds by the large stone buttresses that stand at regular intervals along the front of the Abbey, but even these were no defence against last winter's frost; and the particularly healthy appearance of the plants, after what some would call an unnatural treatment, I thought was not only worth notice as an unusual circumstance, but also as suggestive of the question whether we give the plant its proper treatment under glass. Except in a few places, I have seldom seen a healthy plant growing under such protection; red spider and thrips appear to be its greatest enemies, especially if the roots are confined in too small a space, in which case the plants seldom thrive or flower satisfactorily; and as to growing plants in pots, I have never found it worth trying—the growth the plants make is not strong enough to produce more than three or four flowers where there ought to be large clusters. In my opinion the Mandevilla wants plenty of rooting space in a well-drained, deep, rich soil, abundance of water when growing, both at the root and overhead, care to thin out the shoots when growing, and, finally, every means to be adopted to well ripen the wood before the leaves fall.

There are adorning the Abbey walls many other choice plants which are not commonly met with elsewhere in such positions; the vigorous growth and free flowering of most are remarkable. The early maturation of the wood is apparent, also that the roots are in a comfortable medium. The latter condition is no doubt in a great measure owing to the immense quantity of soil brought there to form the upper terrace, which is well drained, and to the great depth and age of the material forming the foundations of the Abbey, and which the roots of the plants are induced to penetrate.—THOMAS RECORD, *Hatfield Gardens.*

A STANDARD EARLY YORK PEACH.

On the 8th of September I gathered the last of thirty-one Peaches from a small pyramid tree that has been standing without any protection throughout the winter and spring: they were rather small, but of excellent flavour and perfectly ripe. I should mention that the variety is the Early York. About fifteen days prior to this I gathered the fruit of Rivers's Early York from a tree against an oak fence, so there was not much difference in the ripening as regards protection, Rivers's variety being said to be about ten days earlier. I know that this is not the first time the above Peach has ripened its fruit without a wall or protection, but I thought I would call attention to it, as others might like to try a bush or a pyramid where they had little or no wall to spare.—HARRISON WEBB, *Weirleigh, Kent.*

ROYAL HORTICULTURAL SOCIETY.

We noticed in our last issue that the Society had resolved to hold its country exhibition in 1871 at Nottingham. On Thursday, September 1st, a supplementary meeting to that reported by us at page 159 was held in the Mayor's parlour

at Nottingham to consider certain important details and arrangements. Amongst those present were Mr. E. J. Lowe, Mr. Pearson, of Chilwell, and Mr. Ingram, of Belvoir Castle Gardens. From the thoroughly earnest manner of all present, and the announcement of the numerous promises already made of liberal sums towards a guarantee fund, it is very probable that a most successful provincial exhibition will at length be held by the Royal Horticultural Society.

THE METROPOLITAN FLORAL SOCIETY'S FIRST SHOW.

ALTHOUGH your reporter has already given a full report of this wonderful exhibition, yet I cannot allow it to pass without recording a few observations which have struck me as connected with it.

1. It proves conclusively that the race of florists is not dead or buried under the superincumbent mass of bedding-out plants, or sick at heart through the unworthy attacks of those who are now far too magnificent to allow themselves to be styled florists. Never had a more unfavourable season been experienced by florists. The long-continued drought had not only made it indeed a labour of love to attend to the wants of their flowers, but it had so forced prematurely into bloom many such as the Hollyhock and Gladiolus, that some advised we should postpone the show for a year, as it was not possible that we could obtain flowers; yet, withal, the skill and perseverance of the poor despised florist conquered all difficulties. It required no small amount of constant care and attention, watering, shading, &c.; but florists are a hard-working race, they take pride in their pets, and the result was the grandest show of cut flowers ever held.

2. It shows the great advance that has been imperceptibly made in the quality of florists' flowers. In talking about the show to many people before it was held one gentleman remarked, "The Dahlias—ah! there's nothing to be done with that; you can't improve upon it." Yet I venture to say such stands of flowers as were shown at the Palace were never exhibited before. We sometimes look back on the past, all with the old feeling, *laudator temporis acti*, and think that no days were like those; but could we conjure up a stand of forty-eight Dahlias such as used to be shown at the Surrey Gardens in days gone by, and place them alongside of those Mr. Keynes or Mr. May exhibited last week, I venture to say horror would seize us to think we could ever have praised those older flowers. The Gladiolus, too, was unknown then save in a few now-discarded flowers, and what a gorgeous addition they are to an autumn show! How magnificent the spikes of Mr. Kewey and Messrs. Stuart & Mein! Hollyhocks, too, thanks to Mr. Chater, Messrs. Downie, Laird, & Lang, Mr. Hawke, and others, are as different from the flowers of those days as light from darkness; and although we have been running rather too much on light and undecided colours, yet some magnificent scarlets and dark flowers were exhibited the other day. My experience goes back now through a good many years. I have visited many autumn shows, and I unhesitatingly declare that such a show was never before held in or near the metropolis.

3. It shows clearly that if prizes are offered, good in amount and reasonably adjusted, you will induce competitors to come forward from all parts. By "reasonably adjusted" I mean giving small growers a chance—not putting the nurseryman who has his hundred acres on a par with the man who has only a dozen, or the amateur who grows fifty or a hundred Dahlias with one who grows three or four times the number. In proof of this let me say that the entries were over two hundred; that the best twenty-four Gladiolus came all the way from Kelso, and the best twelve Asters from Shoreditch, two very opposite localities. And that the Show was all I have stated may be gathered from the following comparative table—

Exhibition of 1870.	Last Autumn Show at Crystal Palace.
Dahlias 85 entries 24 entries.
Asters 33 6
Hollyhocks 18 5
Verbenas 8 2
Gladiolus 12 5

This, I think, conclusive; and as to quality, the opinion has been very decidedly expressed by all who visited the Show, that it was really wonderful.

And now as to our future. I cannot but look forward hopefully; and for the success that has been attained I have to thank many kind friends. The Judges, who were the very best that could be obtained, gave their services gratuitously, and

worked with a hearty good will; the exhibitors were courteous and thankful for the exertions made, and were neither the rogues nor simpletons some have tried to paint them; and I need not add that my friend Mr. Wilkinson gave every aid that courtesy and kindly feeling could do. The assistants at the Palace worked with a hearty good will; and from first to last there was not one hitch—save one, and that we had no control over—the dinner was not what it ought to have been; at this we gumbled, and rightly. Our Committee is formed; and when I saw it include such honoured names as Turner, Keynes, Hughes, Peach, Holmes, Fraser, Cutbush, &c., I have no fear of a successful course. Already one gentleman has promised special prizes for new Dahlias, others have doubled their subscriptions, new members have been added, and I think the florists will show that they can keep alive a Society which they have thus happily inaugurated.—D., Deal.

RUNNERS FROM BARREN STRAWBERRIES.

AMONGST the various articles on Strawberry culture in your Journal, those on non-productiveness of runners taken from sterile plants have particularly interested me, and from a series of experiments carried on during several years I am satisfied that now the best and strongest runners have been sacrificed to a theory quite at variance with facts. I give you a table of my trial in 1869—70, and this was carried on under my own inspection; every plant from which runners were taken I marked myself. The parent plants which were barren in 1869 and which were fruited in 1870 are marked with an asterisk (*).

In 1870.

President.....	144	runners 11	barren.	Mostly barren.
Premier	96	" 8	barren.	Several barren.
*Turner's Seedling	24	" none	barren.	All old plants fruited.
*Vicomtesse Horti-	48	" none	barren.	"
cart de Thury				

—J. L. THOMAS, *The Cottage, Macclesfield.*

EARLY GARDEN PRODUCE FROM CORNWALL.

VERY few persons are aware of the earliness and value of some of the garden produce from South Cornwall. Many times we have heard the first early Potatoes in Covent Garden Market stigmatised as "stale foreign things," when we knew the very plot of ground beyond Penzance from which those Potatoes had been dug not twenty-four hours before. The following interesting statement was recently made by Mr. Dentigh, of the West Cornwall Railway:—The average despatch of Potatoes from the railway station for the past eight years has been 2337 tons per year, and of Broccoli 2627. The largest despatch of Potatoes was in 1863—3116 tons; and of Broccoli, 1868 3571 tons; the smallest—Potatoes, 1868, 1418 tons; Broccoli, 1867, 1544 tons. For the last season the quantities were respectively—Potatoes, 2591 tons; Broccoli, 2574. These crops are very similar in amount, for the successful cultivation of the Broccoli largely depends upon the land being previously occupied by the Potato. Mr. Thomas had given him the following figures:—

	Acres.	Wages.	Average Value per acre.	Total Value.
Broccoli	500	£2000	40	£20,000
Potatoes	509	45 0	50	25,000
Raspberries	10	80	40	400
Gooseberries	50	400	80	1500
Black Currants	25	200	85	875
Asparagus	7	20	60	420
Onions	80	800	40	3200
		£8000		£41,335

PLANTS FLOWERING IN AUGUST.

August 3. <i>Dracopcephalum speciosum</i> <i>noobilavicum</i> <i>Malva Mireni</i> <i>Achillea tomentosa</i> <i>serata</i> <i>macrophylla</i> <i>compacta</i> <i>Echinops Nitro</i> <i>Scdum Telephium</i> <i>Sieboldii</i> <i>variegata</i> <i>spectabilis</i> <i>Schizanthus coccinea</i> <i>Calystegia pubescens</i> <i>Hieracium Pilosella</i> <i>alpinum</i> <i>aurantiacum</i> <i>Physalis Alkekengi</i> <i>Plumbago capensis</i> <i>Cupilea platycentra</i> <i>Coletia Fesca</i>	August 3. <i>Yucca filamentosa</i> <i>gloriosa</i> <i>Acerodilium roseum</i> <i>Mitrantheca coccinea</i> " 6. <i>Lythrum Salicaria</i> <i>roseum superbum</i> <i>Datura Stramonium</i> <i>Nigella hispanica</i> <i>Helichrysum monstrosum</i> <i>Mesembryanthemum tri-</i> <i>color</i> <i>glabrum</i> <i>Pentstemon ovatum</i> <i>Scoulerii</i> <i>venustum</i> <i>procerrum</i> <i>glabrum</i> <i>Enjans manus</i> <i>metabalis</i> <i>Linum petraeum</i> <i>alpinum</i>
--	--

August 6. <i>Linum narbonense</i> <i>grandiflorum</i> <i>Lewisii</i> <i>Potentilla opaca</i> <i>insularis</i> <i>Phlox Drummondii</i> <i>Arundo Donax</i> <i>Cheilone barbata</i> <i>glabra</i> <i>obliqua</i> <i>Gaillardia grandiflora</i> <i>pieta</i> <i>Dianthus barbatus</i> <i>deltoides</i> <i>Marie Paré</i> <i>superbus</i> <i>petraeus</i> <i>Cyclamen europaeum</i> <i>hederifolium</i> <i>Acanthus mollis</i> <i>Catananche corulea</i> <i>Centaurea argentea</i> <i>candidissima</i> " 9. <i>Linaria splendida</i> <i>Verbena venosa</i> <i>Coronilla varia</i> <i>Iberica</i> <i>Aster Amulus</i> <i>spectabilis</i> <i>levis</i> <i>Novae-Angliae</i> <i>cyaneus</i> <i>Iriza maxima</i> <i>Aloysia citriodora</i> <i>Sanvitalia procumbens</i> <i>Pyrethrum grandiflorum</i> <i>Golden Feather</i> <i>Scabiosa lutea</i> <i>Whitlavia grandiflora</i> <i>Sphenogyne speciosa</i> <i>Gnaphalium margarita-</i> <i>ceum</i> <i>Erica stricta</i> <i>rubraefolia</i> <i>vagans</i> <i>ciliaris</i> <i>Adonis aestivalis</i> <i>autumnalis</i> <i>Tradescantia virginica</i> <i>corulea</i> <i>Cacalia coccinea</i> <i>aurea</i> <i>Vinca minor</i> <i>Tritoma Uvaria</i> " 12. <i>Lathyrus grandiflorus</i> <i>Anagallis grandiflora</i> <i>Breweri</i> <i>Okalis Bowieana</i> <i>Roribunda</i> <i>speciosa</i> <i>versicolor</i> <i>Lychnis chalcidonica</i> <i>coccinea</i> <i>Rudbeckia lacinata</i> <i>Newmanni</i> <i>Alonsoa grandiflora</i> <i>Brachycome Iberidifolia</i> <i>Ammobium alatum</i> <i>Viola montana</i> <i>tricolor</i> <i>cornuta</i> <i>lutea</i> <i>Clintonia pulchella</i> <i>Collinsia bicolor</i> <i>Clematis integrifolia</i> <i>erecta</i> <i>Jackmanni</i> <i>Gazania sulcensis</i> <i>Amaranthus spectosus</i> <i>hypochondriacus</i> <i>Oenothera acumin</i> <i>grandiflora</i> <i>biennis</i> <i>macrocarpa</i> <i>Fraseri</i> <i>Crepis virens</i> <i>Aster tenellus</i> <i>Athanasia annua</i> <i>Calliopsis Burridgei</i> <i>tinctoria</i> <i>Mirabilis Jalapa</i> <i>lutea</i> <i>striata</i> <i>Reseda lutea</i> <i>odorata</i> <i>Abronia umbellata</i>
--

August 12. <i>Callirhoe digitata</i> <i>pedata</i> " 15. <i>Commelina colestis</i> <i>Erinus alpinus</i> <i>Clarkii</i> <i>Hypericum perforatum</i> <i>Tagetes patula</i> <i>Saponaria ocymoides</i> <i>Callichroa platyglossa</i> <i>Calendula Pongei</i> <i>Veronica candida</i> <i>incana glauca</i> <i>spicata</i> <i>elegans</i> <i>Balsamina hortensia</i> <i>Convolvulus major</i> <i>Epilobium hirsutum</i> <i>Calandrinia umbellata</i> <i>Asclepias tuberosa</i> <i>Iberis cornuta</i> <i>alba</i> <i>Lysimachis Nummularia</i> " 19. <i>Mandrandia Barclayana</i> <i>Primula cortusoides</i> <i>Campanula Lorei</i> <i>pentagonia</i> <i>Centranthus macrosiphon</i> <i>Hibiscus africanus</i> <i>Cladanthus arabicus</i> <i>Phlomis Russelliana</i> <i>Polygonum Brunoni</i> <i>Sieboldii</i> <i>Salvia fulgens</i> <i>patens</i> <i>splendens</i> <i>bicolor</i> <i>arctica</i> <i>Delphinium Consolida</i> <i>Ajacis</i> <i>Funkia corulea</i> <i>ovata variegata</i> <i>undulata</i> <i>Campanula rotundifolia</i> <i>Senecio elegans</i> <i>Lavatera trimestris</i> " 22. <i>Portulaca splendens</i> <i>Thellusoni</i> <i>coccinea</i> <i>Saponaria calabrica</i> <i>Epilobium angustifolium</i> <i>Delphinium Belladonna</i> <i>Lewi</i> <i>Anemone japonica</i> <i>Matthiola annua</i> <i>Calendula officinalis</i> <i>Lathyrus odoratus</i> <i>magellanicus</i> <i>Helianthus annuus</i> <i>Lotus corniculatus</i> <i>Malcolmia maritima</i> <i>Zinnia elegans</i> " 26. <i>Tropaeolum peregrinum</i> <i>Sedum cereuleum</i> <i>Heliotropium mexicanum</i> <i>Acapantus umbellatus</i> <i>Lobelia Erinus</i> <i>ramosa</i> <i>Alyssum saxatile</i> <i>Anchusa italica</i> <i>Lupinus luteus</i> <i>Pentstemon gentianoidea</i> <i>coccineum</i> <i>Schizanthus pinnatus</i> <i>splendens</i> <i>Silene rubra</i> <i>Viscaria oculata</i> <i>Ecceborarpus scaber</i> <i>Tigridia Pavonia</i> <i>ombiflora</i> " 30. <i>Leptosiphon densiflorus</i> <i>aureus</i> <i>Anthericum Lillago</i> <i>Astille rivalaris</i> <i>Silene compacta</i> <i>maritima plena</i> <i>Schaftii</i> <i>Calandrinia speciosa</i> <i>Tritonia aurea</i> <i>Statice Gmelini</i> <i>Linaria alpina</i> <i>Cynbalaria</i> <i>Hydrangea</i> <i>Iberis Tenoreana</i> <i>Lilium speciosum album</i> <i>rubrum</i> <i>Helenium autumnale</i> <i>Liatris elegans</i> <i>Gladiolus ramosus</i>

—M. H., *Acklam Hall, Middlesbrough-on-Tees.*

GRUBS DESTROYING THE TURNIP CROP.

THE grubs which have devastated "acres upon acres of Turnips in East Kent" are the caterpillars of the *Agrotis segetum*, a moth which in the dry season of 1864 also committed great mischief on nearly all sorts of vegetables, and which the long drought during the present year has also developed to a fearful extent; the moths having been enabled to lay their eggs without interruption by wet in June last. The earth round the crowns of the plants should be carefully moved by hand, and the grubs, often several at one root, picked out and destroyed. They are now nearly full grown, and will soon bury themselves deeper in the earth to undergo their transformations. When the earth is moved by the plough in the spring children should be employed to pick up the chestnut-coloured shining chrysa-

birds, or they may be left to the rooks if there are plenty in the neighbourhood. Fowls will also eat the grubs greedily, but will not hunt for them.—I. O. W.

ISABELLA GRAY ROSE.

I HAVE a Rose called Isabella Gray; I have had it for ten years, but it has never flowered, but grows most luxuriantly. Can you tell me the reason, and give me the history of this Rose?—GADGIRTH, N.B.

[Isabella Gray was raised, I believe, in South Carolina, U.S., from the Cloth of Gold; and Maréchal Niel was raised from Isabella Gray by Pradel, jun. It is curious that the parent and grandchild should bloom so freely, and Isabella be so reluctant to do likewise. I have three trees of Isabella Gray 6 feet in advance of my vinery, and so luxuriant that "D., Deal," mistook them for six plants. They have bloomed tolerably freely this summer; and when the buds are hard they are still useful for bouquets. There is no doubt that all yellow Roses prefer hot walls to any other position. It is also true that some reluctant bloomers flower freely with shade to the south of them. William Bull is a glorious first-class Rose in this position, but as hard as a mortar ball when exposed to the sun.

I believe we puff up Roses and puff them out much too soon. A Rose miserable on one stock or in one position in the garden, may be glorious on another stock and in another position. I advise carefully taking up Isabella Gray, and trying a wall, first a south wall and afterwards an east wall. I further advise this variety being planted on the surface, earthing-up like a molehill, so as to allow the sun full action on the roots. In this case, in such a hot summer as the last, the plant should be mulched, and watered copiously twice a week. Under all circumstances it would be well to dig a deep hole under the site before planting, and to sink stones for free drainage. All Tea and Tea-scented Roses like high cultivation, deep drainage, intense heat, and copious waterings. I am not sure as to the raiser. Probably the name was given in honour of one of Asa Gray's family.—W. F. RADCLIFFE.]

NEW BOOK.

The Wild Garden: or our Groves and Shrubberies made Beautiful by Hardy Exotic Plants, with a Chapter on a Garden of British Wild Flowers. By W. ROBINSON, Author of "Alpine Flowers," &c. London: J. Murray.

MANY years ago a gentleman, an ardent lover of natural beauty, wandered through the New Forest, following the route pointed out by the best sketcher and analyst of landscapes, the Rev. William Gilpin, in his "Remarks on Forest Scenery." That volume was our friend's companion, and he saw so many illustrations of one passage in "Forest Scenery," that he resolved to accept it as a lesson and be its copyist. One illustration especially impressed him. On a tongue of high ground stood a weeping Birch, close to it were groups of *Osmunda regalis* Fern, among and above which were pyramids of Foxgloves laden with their pink bells; and the sloping sides, and, indeed, the whole surface, were clothed with the tender green Wood Sorrel, dotted here and there with tufts of low-growing Ferns.

The passage in "Forest Scenery" referred to is this:—

"The larger kinds of weeds, and wild flowers have their effect in filling up the smaller vacancies near the ground; and add to the richness of the whole. Among these, the Heath, and Broom, with their purple and yellow tints; the Foxglove with its pale red pendent bells; the wide-spreading Dock, and many of the Thistle tribe, are very beautiful. The hne of the Furze, too, is pleasant; but in bloom its luxuriant yellow is too powerful. Nothing can accompany it.

"But among all the minuter plants, Fern is the most picturesque. I do not mean where it is spread in quantities, but where it is sparingly and judiciously introduced. In itself it is beautiful. We admire the form of its leaf, its elegant mode of hanging, and its dark-brown polished stem. As an accompaniment, also, nothing is better suited to unite the higher plants with the ground; while its bright-green hue in summer, and its ochre tint in autumn, join each season with its correspondent tinge.

"Of all this undergrowth I know but one plant that is disagreeable, and that is the Bramble. We sometimes see it with effect scrawling along the fragments of a rock, or running among the rubbish of a ruin; and though it is even then a coarse appendage, I should not wish to remove it from landscape. But as a pendent plant it has no beauty. It does not hang carelessly, twisting round every support, like the Hop,

and others of the creeping tribe; but forms one stiff, nopliant curve. Nor has it any foliage to recommend it. In other pendent plants, the leaf is generally luxuriant, and hangs loosely in rich festoons; but in the suckers of a Bramble the leaf is harsh, shrivelled, and discoloured. In short, it is a plant, which should not, I think, presume in landscape farther than hath just been allowed: it has little beauty in itself, and harmonises as little with anything around it; and may be characterised among the most insignificant of vegetable reptiles."

Our friend did copy and illustrate that passage, using, however, for garnishing his shrubbery, not only our native Ferns and flowering plants, but hardy exotics, *Aconites*, *Hepaticas*, *Mezereons*, and others now too rarely found anywhere but in the gardens of old people who still wear poked bonnets and blue coats with gilt buttons.

What our friend did Mr. Robinson advocates—well advocates—in the volume before us. He does, however, much more, and does that well also. He gives descriptive classified lists of the plants suitable for ornamenting our shrubberies, and tells the soils and situations those plants prefer. "My object," says Mr. Robinson,

"Is to show how we may, without losing the better features of the mixed bedding or any other system, follow one infinitely superior to any now practised, yet supplementing both, and exhibiting more of the varied beauty of hardy flowers than the most ardent admirer of the old style of garden ever dreams of. We may do this by naturalising or making wild innumerable beautiful natives of many regions of the earth in our woods, wild and semi-wild places, rougher parts of pleasure grounds &c. and in unoccupied places in almost every kind of garden."

"My reasons for advocating this system, as I do, are as follows:—First, because hundreds of the finest hardy flowers will thrive much better in the places I recommend for them than ever they did in the old-fashioned border. Even comparatively small ones, like the Ivy-leaved Cyclamen, a beautiful plant that we rarely find in perfection in gardens, I have seen perfectly naturalised and spread all over the mossy surface of a thin wood. Secondly, because they will look infinitely better than ever they did in gardens, in consequence of fine-leaved plant, Fern, and flower, and climber, ornamental grass, and dwarf trailing shrub, mutually relieving each other in ways innumerable as delightful. Any one of a thousand combinations, which this book will suggest to the intelligent reader, will prove as far superior to any aspect of the old mixed border, or the ordinary type of modern flower garden, as is a lovely mountain valley to a country in which the eye can see but canals and hedges. Thirdly, because, arranged as I propose, no disagreeable effects result from decay. The raggedness of the old mixed border after the first flush of spring and early summer bloom had passed was intolerable, bundles of decayed stems tied to sticks making the place look like the parade-ground of a number of crossing-sweepers with their arms piled. When Lilies are sparsely dotted through masses of *Rhododendrons* as I recommend, their flowers are admired more than if they were in isolated showy masses; when they pass out of bloom they are unnoticed amidst the vegetation, and not eyesores, as when in rigid unrelieved tufts in borders, &c. In a wild or semi-wild state, the beauty of individual species will proclaim itself when at its height; and when passed out of bloom, they will be succeeded by other kinds, or lost among the numerous objects around. Fourthly, because it will enable us to grow hundreds of plants that have never yet obtained a place in our 'trim gardens,' nor ever will be admitted therein. I allude to the multitudes of plants which, not being so showy as those usually considered worthy of a place in gardens, are never seen there. The flowers of many of these are of the highest order of beauty, especially when seen in numbers. An isolated tuft of one of these, seen to a formal border, may not be considered worthy of a place at any time—in some wild glade, in a wood, associated with other subjects, its effects may be exquisite."

Mr. Robinson assigns other good reasons, but here we must close our notice. We recommend the book, for it will help to increase the beauty of all pleasure grounds, whether around a small villa or encircling a princely mansion.

WINTER-BLOOMING ORCHIDS.—No. 7.

COELOGYNE.

THIS is an Indian genus of great interest, which comprises two distinct sets of plants. Some authors separate them into two genera, *Coeologyne* and *Pleione*, whilst others consider the latter only a sub-genus. I consider them, however, well deserving of generic rank, and as such I shall treat of them here. The *Coeologynes* are all compact-growing plants, and readily become handsome specimens; they recommend themselves also on account of many species thriving well under cool treatment.

Coeologyne is a somewhat extensive genus, but I must here confine myself to the best of those which enliven our dull months. In order to produce good flowering plants, the majority of them should be potted, at the same time they must be well elevated above the rim of the pot, and the pots must be well drained. The soil should be good fibrous peat, a little sphagnum

moss, and sand; and in addition I have used, with advantage, a small portion of good leaf mould, but it must be good. During the growing season the species of *Celogyne luxuriante* in a plentiful supply of water both upon the foliage and at their roots; when growth is complete gradually withheld water, and expose them well to the influence of sun and light, in order to ripen their growth, whilst during winter a very small quantity of water will suffice.

C. CRISTATA.—This is, perhaps, one of the most elegant of winter-flowering Orchids, compact in its habit of growth, with dark green ovate pseudo-bulbs about 3 inches in length, bearing two linear-lanceolate, somewhat leathery, dark green leaves, with wavy edges. The flowers are produced in nodding racemes, four or five together, each flower being about 4 inches in diameter; sepals and petals oblong-lanceolate, the former narrower than the latter, all with undulated edges, and of the palest snow white; lip also white, concave, having five raised parallel lines along the centre, which are fringed or crested, and suffused with clear delicate yellow. This lovely plant lasts a considerable time in full beauty; it is extremely ornamental in the plant house, and it may be removed to the drawing-room without injury. It is also admirably adapted for adorning ladies' hair. Native of Sikkim, at 6-7000 feet elevation.

C. CORRUGATA is a much smaller plant than the preceding. The pseudo-bulbs are ovate and wrinkled; leaves in pairs, oblong, somewhat acuminate, membranous, and dark green. Racemes erect, bearing from three to six flowers; sepals and petals oblong-acute and pure white; lip smaller, white, yellow inside, and streaked with orange, having three raised parallel lines on the disc. A rather uncommon but very elegant cool-house species. Native of the Madras Hills.

C. FLACCIDA.—This species produces drooping spikes of flowers, which are strongly but not very pleasantly scented. Pseudo-bulbs oblong and ribbed; leaves long, somewhat lanceolate, petiolate, dark green, and leathery. Racemes zigzag, drooping, and many-flowered; sepals and petals white; lip white with a yellow centre, recurved at the point, and toothed at the base, where it is streaked with crimson. The plant will succeed either in a pot or upon a block; in the latter manner its drooping racemes are displayed to the greatest advantage. It blooms during January and February, and during the growing season requires more heat than the kinds previously named. Native of Nepal.

C. SPECIOSA.—This plant is more properly an autumn flowerer, but as at this season flowers are scarce, it well deserves a place in every amateur's collection. The pseudo-bulbs are ovate-oblong in shape, and bear a single oblong-lanceolate dark green leaf. The flowers are about 3 inches in diameter, and usually produced in pairs; sepals and petals reflexed, dull brown; lip large, crested in the centre, of the same colour as the petals, with the front portion white. Native of Java.

C. ODORATISSIMA.—An elegant but small-flowered kind. The small size of the flowers is no doubt the reason of its being so little grown, but being white and sweet-scented they are very acceptable for cutting during March and April. The whole plant seldom exceeds 6 inches in height, both pseudo-bulbs and leaves. The flower-spike, which is produced simultaneously with the young growth, is drooping, and bears about three flowers, which are all white except the centre of the lip, which is yellow. It is a cool-house plant from the mountains of Madras.

C. GARDNERIANA.—A plant far less grown than it deserves to be. The pseudo-bulbs are somewhat flask-shaped, tapering upwards from the base; leaves from 10 to 18 inches long, and about 3 in breadth, lanceolate, acuminate, petiolate, and bright green; the racemes are slightly drooping, bearing from six to eight large flowers, which are pure white, saving the centre of the lip, where it is stained with lemon colour. Native of East Indies, in Nepal, and Khasia.

C. OCELLATA.—This species should be grown upon a block of wood, where it will form an elegant specimen, and produce its chaste flowers during February and March. The pseudo-bulbs are shining, ovate, and angular; leaves lanceolate, narrow at the base, and about 10 inches long. Flower-spike 6 inches or so in length; sepals and petals white; lip of the same colour except at the base of the middle lobe, where there is a yellow spot, and the lateral ones are also stained with deep yellow. Native of Khasia and Sylhet.

C. FUSCESCENS is, perhaps, the least desirable species, especially if the collection is small, or the space limited. However, where the space for two or three pots more or less is not of vital importance, this plant should find a place. The pseudo-bulbs are about 4 inches high, round, and rather thin, bearing

oblong acute leaves 9 inches in length, and nearly 3 broad; raceme nodding, and bearing about five good-sized brown and green flowers. It succeeds in a cool house. Native of Nepal.—*EXERTO CREDE*.

PORTRAITS OF PLANTS, FLOWERS, AND FRUITS.

CEREUS FULGIDUS (Brilliant-flowered Cereus). *Nat. ord.*, Cactaceae. *Linnaeus*, Icosandria Monogynia.—The history of this flower is unknown. It has bloomed annually at Kew for many years. Flowers scarlet, opening early in an evening, and remaining expanded until the following noon.—(*Bot. Mag.*, t. 5856.)

BRODIAEA COCCINEA (Crimson-flowered Brodiaea). *Nat. ord.*, Liliaceae. *Linnaeus*, Hexandria Monogynia.—It is a brilliant-flowered bulbous plant, native of California, blooming in May and June. Flowers crimson, tipped with yellow and green.—(*Ibid.*, t. 5857.)

ONCIDIUM CRYPTOCOMIS (Long-sepalled Oncidium). *Nat. ord.*, Orchidaceae. *Linnaeus*, Gynandria Monandria.—Native of Peru. Flowers brown, edged with yellow.—(*Ibid.*, t. 5858.)

TABERNEMONTANA BARBERI (Mr. Barber's *Tabernemontana*). *Nat. ord.*, Apocynaceae. *Linnaeus*, Pentandria Monogynia.—Native of Old Calabar and other districts of the tropical west coast of Africa. Glabrous shrub. Flowers white.—(*Ibid.*, t. 5859.)

SALVIA INTERRUPTA (Ash-leaved Sage). *Nat. ord.*, Labiatae. *Linnaeus*, Didynamia Gymnospermia.—"A tall hardy herbaceous plant, with a woolly suffrutescent stem, belonging to the same set of Sages with *S. officinalis*, and many other handsome species that are common ornaments of continental gardens, but are all but wholly unknown in our own. It was, according to the 'Hortus Kewensis,' formerly cultivated in the Royal Gardens under the name of the Ash-leaved Sage, having been originally introduced from Morocco into the Cambridge Botanic Garden, 1798. It has, however, long since disappeared from cultivation, and so remained till three years ago, when it was reintroduced from Tangiers by G. Maw, Esq., of Benthall Hall, during a botanical expedition into North Africa, from whence he sent living plants to the Royal Gardens that flowered in May of last year. From its habit of flowering through several successive months, it is well worthy of cultivation in the open border."—(*Ibid.*, t. 5860.)

PRIMULA CORTUSOIDES AND ITS VARIETIES.—"In the large Japanese varieties of *Primula cortusoides*, so much superior to the ordinary form as to appear quite distinct, we have acquired some of the choicest and most beautiful materials for ornamenting the hardy flower garden. The public are indebted to the late Mr. John Gould Veitch for the introduction, and to the Messrs. Veitch & Sons for the distribution of these charming hardy plants. *Amæna* is of the richest magenta, with white centre, and has notched but otherwise entire segments; *striata*, a pretty lilac, which has the margin of the flowers toothed, and the colour prettily striated; and *grandiflora*, remarkable for its drooping concave or cup-shaped form, and for having the inside almost pure white, while the outer surface is of a rosy purple hue. The variety *striata* has been sometimes called *lilacina*, a name which is now cancelled. Besides these, there are *alba*, with pure white blossoms, and *albida*, with blossoms of a greyish white, and of the same drooping type as *grandiflora*. These *Primulas*, grown in pots, form excellent decorative plants for cool houses in spring."—(*Florist and Pomologist*, 3rd s., iii., 193.)

WEEDS.

(Continued from page 128.)

THE removal of weeds being conducive to the value of a crop, their extirpation must be an important means of keeping up the fertility of the soil, and securing an increased produce. It is impossible to have a good crop if it is weedy, as the soil's fertility is wasted on the weeds instead of being devoted to the crop.

Apart from the deficiency in produce, and the waste of the soil's fertility, the evil effect of weeds presents itself in many forms of disease to which vegetable life is subject when deprived of light and air. To allow weeds to grow as well as the crop is simply to cause the production of drawn, weak plants, incapable of supporting themselves against wind and rain; whilst in times of drought weeds are a direct cause of the crop lagging behind, the ears of corn not filling, and the roots not swelling. Half and more of the failures and deficiencies of the agriculturist are a result of the little care taken, as a rule,

to keep down weeds. He looks upon them as altogether contemptible. What is the use of imposing penalties for the adulteration of seeds when we see the agriculturist so heedless of the growth of weeds with his crops, and the ripening of their seeds with his grain? It is not the weed seeds sown with the seed of his crops that the farmer has to fear, but those he harvests with every crop, and which, being rejected by his animals, find their way to the fields again with the manure.

Some very nice calculations have been made as to the increase some weeds are capable of by their seeds in the course of a year; but can anyone tell the decrease in the yield of Wheat, Barley, Oats, and other crops caused by the unrestrained growth of weeds? Some will, no doubt, jump to the conclusion that the deficiency is of no practical moment. Presuming that to be case, and I cannot for a moment admit it, how does it happen that the best and most profitable farming is that which is the cleanest? Or, why should gardens afford more than double the produce of the best land of the agriculturist? Is it because the system of culture is different the ground more deeply dug, more manure applied? Or can it be that the weeds as they appear are cut down, the whole resources of the soil reserved for the plants it is cropped with? "Oh, but gardens do not pay!" The fact is they do pay, and the ground is worth twice, often four times as much rent as the same land is let for to the farmer. I have no doubt but that the yearly produce of every acre of land in Britain would be doubled were the ground kept as clear of weeds as it is by the gardener. What is the practical value of draining, of deep cultivation, and manuring, if the resources of the soil be expended in a growth of weeds, in many cases little inferior to that of the crop? Where good crops are reared, there are good cultivation and freedom from weeds.

I have digressed, and could digress very wide of my purpose, to endeavour to show that the land of this country is not agriculturally so productive as it is horticulturally, and that if it is to be rendered more productive, such a result will be attained by a system like that of the gardener—by deep cultivation, free exposure to the air, and allowing nothing to grow upon it except those cultivated plants essential to the health and comfort of man.

No one knows better than the gardener and amateur what are the injurious results of weeds permitted to grow with plants or crops of any kind. It is well known that fall good crops are not had along with a profusion of the plants which the ground naturally produces. Whatever is sown or planted does not attain perfection without an array of weeds, each seeking the continuation of its kind; therefore to secure a good crop, whatever it may consist of, the ground must not be occupied by anything else.

For the successful cultivation of every plant it is essential, first that the soil be open, affording free access of water, air, and manurial agents to the roots of plants; secondly, that the plants have air and light. To secure the former result the soil must be frequently stirred, and the more it is stirred both as regards depth and frequency the more vigorous are the plants. The deeper the cultivation the less is the danger from drought, for the roots penetrate further, and the inert soil, exposed to air, slowly and surely yields to its influence, whilst a loose surface admits the rain and dew, and allows a freer admission of air and solar heat than a hard close surface. This is well exemplified by land of which one part is surface-dug and another part trenched. There is no comparison between the crops. The first suffers from drought, the growth is weak, and the produce correspondingly small; but the latter withstands drought well, the rains penetrate more deeply and more regularly, and the plants are more vigorous and attain a higher degree of perfection. Whilst in the one case there is a weedy crop, in the other it is remarkably clean.

When plants are sown and allowed to attain maturity close together, being deprived of light and air, they have a weak growth. The support taken from the soil is divided between many plants, and light and air having diminished access to the plants, the nutriment is imperfectly elaborated; hence they are drawn up weakly, and the produce is poor. On the other hand, if plants have space for their full development, and are exposed to light and air, they are strong and attain a high degree of perfection, the produce being greater and of better quality. Every plant left in the ground beyond what can have proper support and due exposure to light and air is a robber—in fact a weed. If we plant Cabbages at 1 foot apart we know that the produce is not equal in quantity to what it is with half the number of plants at 2 feet apart; therefore we may, by

having twice as many plants on the ground as it can support or can have light and air, obtain a result no better than were we to allow weeds to grow with what we sow or plant. Weeds have the same influence on our crops as allowing too many plants to grow in a given space—two, three, or more where one only should be. They waste the soil's fertility, deprive the cultivated plant of part of its sources of support, and keep from it the essential agents for elaborating the sap—light and air. There is this difference, however, that whilst a thick seeding or planting will give produce less in quantity and inferior in quality, weeds allowed to grow with plants at a proper distance, whilst they cause a less and inferior yield of the cultivated crop, like thick sowing or planting, cause nothing but vexation present and future.

The object of all cultivation is to secure crops of plants useful to man. All soils have a greater adaptability for the growth of some plants rather than others, hence increased facilities are afforded for the cultivation of a greater variety of plants than were all soils alike in their constituents. Naturally we have plants suited to every soil, situation, and climate, whether these plants are in a natural or in a cultivated state. All vegetation improves with cultivation, though some have ideas of there being such a thing as degeneration, whereas everything in nature is advancing towards perfection, cultivation causing nature to show itself in new and improved forms. To make the ground suitable for the plants affording support and enjoyment to man it must be improved, the original vegetation got rid of, or to such an extent as to be rendered subordinate to that intended to supplant it, and he cannot fit the soil for the reception of a cultivated plant without removing the original vegetation; the means necessary to secure a cultivated plant's free growth and maturity being the readiest means of freeing the land of the obnoxious weeds. Indeed, the whole system of culture is based on the extermination of useless plants, and rearing in their place those which are useful. Still we cannot cultivate the ground without first clearing it of the original vegetation; nor, in the second place, can we have a cultivated crop without weeds, for however well the ground may be prepared plants will come up which we must remove, or if we allow them to remain we must submit to a decrease in the value of the crop. If we turn a bog into a dry place we do not find the land become barren; the bog or marsh plants disappear, and are replaced by vegetation of a very different class, and in turning up a piece of the original wild, completely destroying the present vegetation, the soil gives us vegetation in another form in its place. No art of man is sufficient to prevent vegetation appearing without rendering the soil wholly unsuitable for the growth of plants.

Now, the best means of destroying weeds is preparing the ground for the plants we wish to cultivate. The first, and, perhaps, the most important part of cultivation is draining. "And what has this to do with the destruction of weeds? If it improve the ground for a cultivated plant, the weeds must grow all the more rank as a consequence!" We must not lose sight of all our labour being expended for a cultivated plant, one that from cultivation is more tender, and less capable of enduring hardships than one in its wild state. A plant is rendered less hardy by cultivation; we require for its growth more warmth, which is afforded by draining, which removes all the water that would otherwise lodge in the subsoil, and leaving none but what the soil is capable of returning. In this way the soil is rendered warmer, for the rains, which are charged with ammonia, pass directly to the roots, and containing less water the soil is more quickly warmed by the sun. It absorbs heat and moisture better, and air has access to it; besides, water is slower in heating than any kind of soil, consequently to have an undue amount of water in the soil is to reduce the soil's heat-absorbing power, and consequently warmth. Though for cultivated plants it is essential to free the soil of all stagnant water, and to afford a free passage for rain through the soil, doing so is certain destruction to some native plants, or what are in many places noxious weeds, and without draining it is extremely difficult to make them secondary to a cultivated crop. It would be useless to seek the destruction of the Horsetails or Equisetums by any other process of culture than draining. Cutting off the tops weakens them to a considerable extent, but they root so deeply that any injury to the tops is soon repaired, and there are times when their tops must make headway, and the roots are consequently strengthened; but if we drain the soil, remove the water from the subsoil, their growth annually becomes less, and in time they disappear. For the destruction of the Horsetails there is no means but draining.

Not only is it necessary for destroying those which grow in soils that are thoroughly saturated, but also for killing those growing where there are no signs of moisture on the surface. The Marsh Horsetails (*Equisetum palustre*, and *E. limosum*), and the Great River Horsetail (*E. fluviatile*), must for their destruction have the water in the soil drained off, and equally so the Wood Horsetail (*E. sylvaticum*), and Corn Horsetail (*E. arvense*). The latter, especially, though often abundant on light shifting sands, is doomed to destruction when the soil is efficiently drained.

Again, in low wet soils there is often a preponderance of semi-aquatic Grasses and allied plants, that in a great measure yield to draining. The *Carex* family, the Rushes (*Juncus*), and many others, owe their existence to moisture in the soil, moisture more than the soil would retain had it an outlet by the sub-soil. Drain the ground where those are, and they disappear.

It would be useless enumerating all the plants of which draining assists in freeing the soil, but I must not pass over *Thistles*, *Docks*, and several others with root stems that penetrate to a great depth, and need for their free, vigorous growth, moisture in the soil, and that to a greater extent than is beneficial to cultivated plants.

The casual observer will have noticed that the natural vegetation occurs in patches of one species of plant in a place, or if there are several, one of them is more vigorous than the others. Now, if we were to drain the ground that grows a great variety of plants naturally, it does not follow that we should destroy every plant, but on the contrary, whilst we destroyed some, others would be invigorated. Fortunately there is no cultivated plant, in this country at least, that is not improved by being grown in well-drained ground; such ground improves every crop in quantity and quality, and entirely changes the character of the natural vegetation. Indeed, so beneficial is draining to us in cultivating the soil, that no one ought to neglect it. It is but seldom that the agriculturist neglects it; but many gardens, and especially small gardens, are not drained at all, or very inefficiently, the weeds grow remarkably strong, and many plants are lost every year from the wetness of the soil. Fruit trees are barren, their growth sappy, or the branches moss-covered. The cause is attributed to bad soil into which the roots have struck, whereas it is all due to the water not having a means of escaping from the subsoil. Measures are taken to keep the roots from descending into the cold, wet subsoil, but no thought is given to the fact that they are wholly unnecessary, the sub-soil were rendered dry by efficient drainage.

Drains to be of service should be deep. The rain must enter by the surface, pass through the soil as if it were a sieve, and be freely carried off. The water should be attracted, as it is by drains, from the surface to the roots, and not allowed to remain there and render the soil a wet, cold, inert mass. Experience points to 4 feet as the most suitable depth for drains. At that depth they are beyond the reach of any cultivated plant.—G. ABBEY.

(To be continued.)

INSECTS INJURIOUS TO THE PEAR TREE.

No. 5.

NARROW-WINGED RED BAR MOTH.

TORTRIX ANGSTIORANA, *DITULA ANGSTIORANA*, *PERDISCA ANGSTIORANA*.

IN AN early volume we warned all cultivators of wall fruit, as soon as they observed in May one of the leaves rolled up, to destroy the little caterpillar within the roll, and to watch for others, because the eggs of the moth from which that caterpillar came continue to hatch for several weeks. That moth is the Narrow-winged Red Bar. These caterpillars appear during May and June; they are about half an inch long, are pale yellowish green, and with the head brownish yellow. A few bristles are scattered over the body. It is a very active caterpillar, wriggling about in most varied contortions when disturbed, crawling with equal facility backwards and forwards, and letting itself down by a single thread from its mouth. It passes into the state of a brown shining chrysalis, rolled up in the same leaves, and from this the moth comes forth in July. The moth is very small, not longer than the



line below our drawing of the insect magnified. The fore wings are reddish brown, in bands of various degrees of darkness. The hind wings are dusky. It deposits its eggs, probably, upon the branches, where they remain all the winter. The caterpillars are most frequently found upon the Apricot, but it also infests the leaves of Pear trees.

SUMMER DROUGHT.

WHEN autumn rains are falling heavily, or spring's late showers appear unwilling to cease, we think not of the summer drought, or its moisture-consuming power; of the dry warm atmosphere which comes to us as though it had passed over burning plains, and which day and night surrounds everything. Yet all vegetation is hastened, or retarded, or suffers from its too long continuance. The summer drought changes all too rapidly the outward aspect of nature; beneath its influence the young growth loses its soft tender green, and assumes, as if by the touch of some fatal spell, the grey matured look of autumn—brown leaves, sap-dried before their time, mingle with summer's brilliant colours; fruits ripen ere they have half attained their size; and Flora, living too fast and working too hard, brings the end too soon. The Rose-bud withers as it opens, and the forced seed-vessels ripen and push away the beautiful petals before they have half enjoyed their blooming season; and the green grass is robbed of its verdure and becomes dust-coloured like the dry soil which is moved over it by every breath of wind. Stunted growth or cessation of growth is everywhere to be met with, for little of real growth can summer's heat accomplish apart from her twin helper moisture. How we tire of the long bright sunny days, and sultry cloudless nights! How man, and beast, and bird, and tree, and flower sicken beneath the scorching heat! Faded and weedy grows all the land; the water sheds are dry in the hills, and silent all the brooks in the valleys, and not a drop of moisture lingers in the *Calceolaria* bags, and wild flowers are not, and poor and withered are the numberless hosts of leaves that crowd the Oak tree. The sheep climb the mountains, or spread over the wolds, and seek in vain the moist sweet grass; and with an angry scream the rooks fly over the desert-like pasture fields; and the wild birds of the hills and woods forget their fears and freely slake their thirst with the home birds.

How we suffer from the summer's drought, and how anxiously we look for a change! We watch the sky, the clouds, and the winds; we look out in the early morning and grieve that the rain has not come, and in the eventide and hope it will; and in the dark hours of the night, when the breeze softly stirs the forest trees, our thoughts are of rain. Long-believed-in signs of a coming change visit us, and thus keep hope alive within our hearts; but even the weather prophets fail to read them aright. Soft, feathery, white clouds adorn the blue sky, tenderly veiling its brightness—"mare's tails" and "mackerel skies," enough with their foreboding to dispirit one on the eve of an excursion; but the clouds melt away and leave only an intenser blue, a heat more consuming in its power. Clouds rise in the east and in the west, they travel with the wind and against it, they meet in angry contest, but a few muttered thunderings and they part and go their separate ways in peace, the dispute settled, and to our loss no rain-tears fall. Threatening winds drive right into the "Noah's ark," boldly painted on a sea of blue, and we point in rapture to the unfailling sign, sure that the deluge will come; but the wind lulls, the ark goes on in safety, and the rain descends not. Nearer and nearer to our vision comes the distant landscape—woods, and fields, and cottage homes, and homes of prayer, all clearly revealed to us in the soft evening light; and we take heart of hope again, for all signs of change cannot surely fail. Yet day after day comes and goes the same; only drier and more irritating becomes the atmosphere, more parched and desolate the land, more autumn-like the summer foliage. The sun rises in glory, and travels in undiminished brightness through the blue immensity, and sets among vapour-clouds of gorgeous colouring, that turn each wayside weed, and blade of grass, and giant tree to burnished gold; but a grey morning follows the yellow sunset, and our momentary hopes are gone.

Then we look nearer home for signs of approaching change of weather that may be trusted in, and we take comfort, nay, almost pleasure, out of suffering, and fail to sympathise fully with the rheumatic pains of the long-ago injured limb, in the certainty there is damp in the air, rain bringing relief at last. All day the sun shines, all night the stars; but in the first

hours of the morning a thick heavy cloud passes low over the country and leaves it bathed in generous dew; nothing living and striving to grow is missed or forgotten, and when the sun comes forth he finds everything sparkling with joy, our pains of the body suddenly depart, but they leave a pain that will not go—a long-unanswered wish.

We become sceptical of signs, though the troubled wind goes sighing through every hole and cranny and unfastened window, and moans away into the far distance. And even our household gods break their accustomed silence, and startle us with strange noises, and stairs creak all night through, as though burglars with shoeless feet were ascending and descending; and veteran spiders come forth from their secret nooks to catch the first breath of moisture, and flies with their impatient visits torment the weary worker, and the pea fowl from the neighbouring garden lifts his discordant voice in louder and still louder notes, and deeper down go the worms in their wondrous search for the necessities of life; and the

swallows fly hither and thither, and hold long converse over the abbey ruins, and we know they are meditating a journey to more genial climates. Cold blows the wind from the north as though in pity; it beats hard upon the trees with a noise as of waves beating upon a rocky shore. The rain comes not, and through the same dusty lanes as the mower led his scanty crop goes the reaper with his golden harvest—a harvest that in the olden times was stored away for winter use, now pressed into the service of summer to supply her needs, to lessen the sufferings of the long summer drought.

At last the change comes, the welcome rain falls, slow at first but sure and certain, touching everything as with a hand of blessing, finding its hidden way among the hills, and giving a voice of gladness to every running brook, a sense of renewed life to every thirsty plant; the poor brown moss comes back to greenness, and every node of grass begins its work of growth anew, and surely all our hearts are filled with thankfulness.—MARD.

GARDENING IN THE LONDON PARKS.—No. 3.
THE CRYSTAL PALACE.

THE elevated position of the Crystal Palace, and the gentle manner in which the grounds slope away from it, tend to impart an additional dignity even to its gigantic proportions; this, and the scenery which it commands, proclaim the hand of a master in the selection of its site.

In a survey of the Palace and its surroundings one cannot fail to be struck by the peculiar tone, which this huge mass of glass and iron imparts to the whole scene. All who read these notes, if they have never seen the Palace, should remember that it is this peculiarity that enables the gardener to form

combinations of such striking colours in the flower beds as would be hardly adapted for small gardens, and which must be followed with the greatest caution, for the bold style of colouring which may be used here with safety, is hardly suited to the quiet repose of the small lawn or shrubbery. Not that I would wish to convey an impression that there are no beds at this place the planting of which may not be safely followed, for many of the circular beds on the rosery slopes are gems of refined beauty, which are quite certain to be appreciated in almost any position.

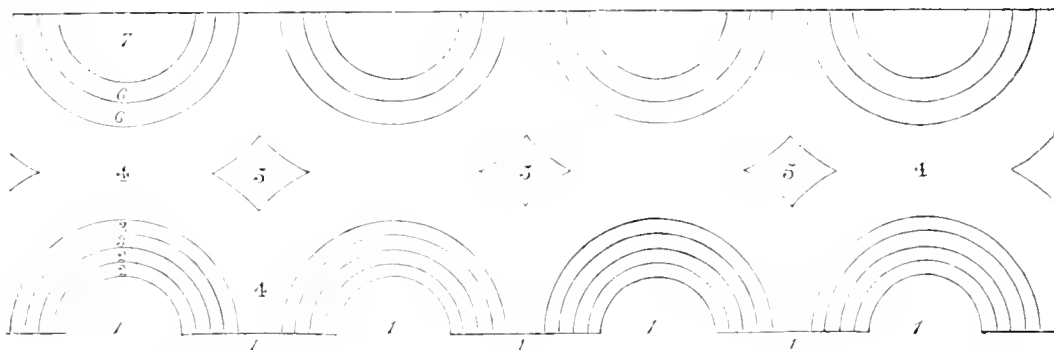

- | | | |
|--|---|--|
| <p>1. Verbena Purple King.
2, 2. Two rows of a Silver-edged Variegated Pelargonium like Perfection or Bijou.</p> | <p>3, 3. Two rows of pink Pelargonium Christiee.
4, 4. Coleus Verschaffelti.
5. Diamonds of Centaurea candidissima.</p> | <p>6, 6. Two rows Pelargonium Crystal Palace Gem.
7. Pelargonium Stella.</p> |
|--|---|--|

The flower beds at the Crystal Palace may be divided into two distinct groups; these are the rosery slopes, and the terrace. Taking the rosery group first, we have a bold mass of colour in the sloping border, which closely encircles the rosery itself. As the arrangement is somewhat complicated, I give the above sketch of the border in order to convey a just impression of its character.

The Coleus was very beautiful; nothing could be more satisfactory than its even compact growth, and the deep rich hue of its foliage. The effect of the entire border, fine as it undoubtedly was, would, I think, have been more pleasing had the flowers been kept picked off the yellow and white variegated Pelargoniums, and this I would insist upon more especially in the case of Perfection, for, situated as it was here between deep purple and bright pink, its white variegation seen pure and simple, as it ought always to be, would have produced an effect both chaste and refined in the highest degree. The dark green foliage of the Ivy and other climbing plants trained over the ironwork behind this border formed an excellent background. The bold style of its colours and its elevated position rendered it a conspicuous object, glimpses of which are visible from all parts of the grounds.

On the lawn sloping downwards from this border were a number of beds, most of which were of a circular form, and about 10 feet in diameter. Many of them were well arranged,

and all were sufficiently quiet in tone to be quite subordinate to the grand border. Of these the best was one having an edging of Pelargonium Flower of Spring surrounding a fine mass of a large-flowered purple Petunia. There were no names to the plants in any of the beds, which was to be regretted, as it robs them of much of their interest. In another bed was a mass of Centaurea candidissima, surrounded by a ring of Coleus Verschaffelti, with a broad edging of Golden Pyrethrum; this was very fine. The Golden Feather Pyrethrum has been remarkably healthy and well-coloured this season in all the gardens in which I have met with it.

Another circle was very attractive; in it Gazania splendens was edged with Echeveria secunda glauca. Another consisted of an equally fine mass of Coleus Verschaffelti, surrounded by a broad band of Centaurea candidissima, with an edging of Lobelia Paxtoniana. The great proportion of white in the flowers of this Lobelia renders it altogether unsuitable for planting next the Centaurea; L. speciosa, or some other deep blue variety, should have been used. A pair of these circles had fine rings of Iresine Herbstii, which has succeeded well in most gardens this season. Another bed, containing a mixture of the pretty Pelargonium Lady Plymouth and Verbena Purple King, was very good; so, too, was a mixture of Verbena venosa and Cineraria maritima. Another striking bed had a broad edging of Golden Pyrethrum surrounding alternate rings

of itself and a very compact-growing blue Lobelia. A novel effect was produced by surrounding a mass of orange and scarlet *Tropæolum* with an edging of *Nierembergia gracilis*; and a very neat and attractive bed contained white, orange, and pink Lantanas. These pretty Lantanas are alike useful in pots and beds, and, although somewhat old fashioned, yet when well managed they bear favourable comparison with all other bedding plants. A few mixed beds of Verbenas were very poor indeed, nor did it appear at all difficult to understand why they were so, for it was evident at a glance that they were planted in the ordinary garden soil, and hence their ragged and starved appearance. This was to be regretted, for, after all, the successful culture of Verbenas is a very simple matter. With a deep, cool, light, rich soil, and healthy plants at the time of planting, there need be no more failures with Verbenas than with Pelargoniums. The only advantage which the latter really possesses is that it will, under favourable circumstances, continue somewhat longer in full beauty than the former. We have only to afford the Verbena a sufficient quantity of that rich, cool soil, in which its roots love to spread, to produce beds of the most exquisite loveliness, and certainly far more attractive and interesting than those of almost any other denizen of the flower garden.

The great utility and beauty of circular flower beds is here fully demonstrated, and while there were several beds the colours of which were tame and their arrangement faulty, yet the majority of them were good in every respect and highly satisfactory.

In the hollow at the foot of the rosey slopes, on the side facing the water temples, a triangular space is enclosed or bounded by three walks, each of which runs parallel with one side of the triangle, which is of turf, having a fine *Wellingtonia* in its centre, and with three small triangular beds, one at each angle of the triangle. Each of these beds contained a mass of a light orange scarlet Pelargonium, with an edging of *Pelargonium Manglesii*, which filled the beds well; but the result would have been very much better had a deep crimson shade of colour been used in place of the orange scarlet, for then a rich and dignified effect would have been obtained; the deep colours blended together would have imparted just that air of importance which the group required to be satisfactory.

Proceeding from this part of the grounds to the terrace, I noticed in full flower some fine bold masses of Hollyhock, which struck me as being one of the best of plants to introduce in that way in such extensive grounds.

The beds on the terrace form no regular design, but are arranged in a single row round the principal plots of turf, each of which has a fountain in the centre, on the margin of which a few vases are placed. The chief display on the terrace was that of the two central groups, one on each side of the broad walk which leads from the Palace across the centre of the terrace down the various flights of steps. The form of each of the central spaces of turf will be easily understood if I compare it to the quarter of a huge oval, with the longest side facing the front of the terrace. The line of beds here consists of alternate circles and parallelograms, the formality of which is broken up by specimen standard shrubs, which spring from the centre of each of the circular beds. The flowers in these consisted of an outer row of Golden Pyrethrum, inside which were two rows of *Colerus Verschaffelti*, with a central mass of Pelargonium Provost. In every alternate circle Pelargonium Flower of the Day took the place of the Pyrethrum. The long beds had a broad band of Pelargonium Stella along the centre, with yellow *Calceolaria* on each side, and with a row of Verbena Purple King round the outside of the beds. The flowers and trusses of the *Calceolarias* were alike small. This long line of bright colours, softened somewhat by the mass of Provost, had a very bold effect, and the proximity of the "pale-hued Palace," deprived it of all its harshness, and even added to its beauty.

The line of beds running parallel to the walk along the other sides of these central plots of turf is peculiar; it consists of circular beds containing an *Araucaria imbricata* in the centre, alternating with very large empty vases, with high pedestals standing on turf, and surrounded by a broad ring having a wide band of either pink or scarlet Pelargoniums along the centre, with a margin of Pelargonium Flower of the Day on each side. These rings had a very good effect; but the circular beds containing the *Araucarias* appeared perfectly ridiculous, owing to the absurdly narrow row of *Cerastium tomentosum* enclosing a broad ring of blue Lobelia.

A line of beds by the side of the walk nearest the Palace, consisting of parallelograms broken occasionally by vases or

statuary, was very good. Of these beds one containing a mass of a very dwarf orange scarlet *Tropæolum*, bordered with an equally dwarf blue Lobelia, was very good; another had a splendid mass of Pelargonium Waltham Seedling. This fine variety has been very brilliant all through the past hot season. In others of these beds equally fine, Pelargoniums Amy Hogg and Provost, and a fine large-flowered purplish crimson *Petunia*, were noteworthy. All these beds had a uniform edging of blue Lobelia. The vases, which were of large and handsome proportions, contained a pleasing mixture of plants, the growth of which was very uniform. These vases, and beds were among the most effective of any that came under my notice, and this was undoubtedly owing to the broad rich masses of colour which the beds contained, for had there been much subdivision of colour here the effect would not have been nearly so telling.

The beds in the other compartments of the terrace contained nothing worthy of note; and I may very justly conclude this paper by observing, that while there is much in the arrangement of the flowers here to which the greatest praise must be accorded, yet there is also very much of the colouring which is faulty and insipid; it may be that there was a lack of better materials at the planting season. Knowing nothing of the resources of the Superintendent, I cannot say how this may be; but I may say that a season trying even as the past hot summer, can form no excuse for the tame appearance presented by many of the minor flower beds in these grounds.—EDWARD LUCKNURST, *Egerton House Gardens, Kent.*

THE FLOWER SERMON.

COLLINSON, in his "History of Somersetshire" speaking of Yatton, says, that "John Lane of this parish left half an acre of ground to the poor for ever, reserving a quantity of grass for strewing the church on Whit-Sunday."

For many years past a sermon upon flowers has been preached in Shoreditch annually on Whit-Tuesday; an old florist, Thomas Fairchild, enamoured of his floral charges, having bequeathed a certain sum of money, in trust to the Royal Society, "for the providing of a clergyman to deliver that sermon." This had been familiar to us, not only as a legend but as a reality, from our childhood's days, for our father had often been invited to preach it; and we, a large party of boys and girls about the tea-table, had been in the habit, for days before, of hazarding many a guess, or even bolder suggestion, as to what the text would or should be. "Consider the Lilies," was a favourite one, being very apposite. But "Much too commonplace, my love," would be the reply to that. "Rose of Sharon" came next; but naturally all these, patent to the minds of everyone, had year by year been used up, and we had to confess, when told, perhaps, that it would be such a one as "He giveth them their meat in due season," and that the discourse would turn upon corn, that it sounded much more "uncommon," and that there would be a great deal to say about it.

Shoreditch was a very long way off, and an out-of-the-way place to take young folks to. We did not attend these annual services, nor in fact were they much frequented by any. Perhaps not more than a dozen persons heard the carefully thought-out sermon, or profited by the lessons which the good old gardener, so long since dead, would have had them taught concerning the beauty and charm of God's creatures.

Knowing all this, which by-the-by, not one in ten thousand Londoners does know, we were taken by surprise when, about a week before Whit-Sunday last, an announcement appeared in the public papers to the effect that "The Flower Sermon, usually preached at St. James's, Aldgate, would this year be preached at the Church of St. Katharine Cree, Leadenhall Street, on Whit-Tuesday evening, by the Rev. W. M. Whittemore, D.D., that the service would be choral, members of St. Paul's Cathedral special service choir attending, that the church would be crowded, and that it was the custom for all the young people present to carry bouquets of flowers."

Our first mental question was, "Is this the Flower Sermon," of which, like so many others who have lived within sound of Bow Bells all their lives, we have never before heard; or has our old acquaintance of poor Shoreditch prior right to the appellation? And then we began to wonder whether other flower sermons of which we knew nothing might be preached at Whit-suntide in other places; and this led us to Collinson's notice of the grass-strewing in Yatton Church on Whit-Sunday.

The evening in question, June the 7th, was bright and balmy. A long drive through streets of holiday-makers streaming to the

prurer air of our "Northern Heights," through dreary Islington, amid street-vendors of sherbet, "water from the cooler" at a halfpenny a-glass, rows of poor little birds in cages, and stalls of wind-fallen fruit and drooping plants, about which ragged children played; on through the busy regions where looms the dome of St. Paul's, and the massive Bank of England rears its heavy walls; brought us at length to Leadenhall Street, and the doors of the old church of St. Katharine Cree.

Beneath the Gothic arched portal of this old church we passed, out of the din of the bustling street, and with difficulty squeezing our way in, truly we were astonished at the sight that met our eyes. An overflowing congregation filling all the square old high-backed pews, lining the nave and aisles, seated on extempore benches, or standing as thickly as elbows would allow, the crowd extended to the porch and even beyond it. For ourselves, having arrived a little late, we were fain to be content—and grateful for it too—with space for our two feet within the sheltering walls of a certain pew where several other ladies also stood during the whole service.

A goodly congregation of men, women, and children it was, although the service is supposed to be chiefly for the latter. Almost everyone carried a bouquet of bright sweet-smelling flowers, Pinks, Geraniums, or Roses, from sober middle-aged spinsters down to the little children in pinafores; indeed, as Dr. Whittemore said, anyone who felt too proud or too old to carry one must feel out of place at this service.

The text chosen was from Canticles—"The flowers appear on the earth;" and Dr. Whittemore called his hearers' attention to five principal lessons from it. First, God's love in giving us bright and beautiful flowers, not as a necessity to our existence, but as a source of deep and pure enjoyment. This he illustrated by a little anecdote of a Strawberry plant given to the inmate of a hospital ward, where, when the possibility was realised of positively a ripe live Strawberry some day appearing on it, the intensest keenest interest grew up amongst the sufferers there, as hour by hour pale wistful faces watched first for a tender bud, then for the little stony blossom, and then for the formation of the tiny fruit, till the universal joy and expectation were crowned by the ripening of the luscious crimson berry. Secondly, the flowers were to teach us faith in God; for if He cares for them, He will for us. And again, eager listening ears drank in the story of the African traveller, lost in a barren expanse of desert waste, who, casting himself down in despair, perhaps, as he thought, to die, presently perceived at his side a tiny blue blossom. "That," he reflected, "has been set here and tended by our Father in heaven. He will not suffer me to perish." And so with renewed hope and courage he rose, and persevered till the route was found. Thirdly, we were to note God's wisdom shown in the subtle and mysterious mechanism to these delicate structures, in their wondrous formation suited to various soils and many climes, in their gradual transformations from seedlings to fruit-bearing growth, causing them to become sweet food for man or beast, and to renew and multiply themselves. Fourthly, God's benevolence, affording to the poorest and youngest, as well as those better off, a means of bestowing innocent pleasure upon others. And lastly, we were reminded of the lesson that all must learn sooner or later, that as the grass withereth and the flower fadeeth, so all our earthly pleasures, even the brightest and the best, must vanish.

This "Flower Sermon," so far as we have since been able to learn, is not in itself an ancient institution, although perhaps an imitation of the older one.

The special service was originated by Dr. Whittemore himself some sixteen or seventeen years ago, in order to interest young people in nature and its teachings.

We wish it all success, and can but hope that it may live to grow into an old custom, and that it may in its turn find other imitators, for we understand that hundreds of persons who would have listened to the Flower Sermon had to turn from the low porch of St. Katharine Cree on Whit-Tuesday night, for want of space within.—(*The Monthly Packet*.)

WORK FOR THE WEEK.

KITCHEN GARDEN.

THE beds of young *Cabbages* should be looked all over, and the most forward plants transplanted or pricked out at once. Continue to earth-up *Celery*. Earthing-up a little at a time and often is the maxim of many; with them it is a rule to sow fresh-slacked quicklime among their *Celery* immediately previous to the first earthing-up. It is found by experience that

the *Celery* bed is the best slug-trap in the garden. A double operation, as it were, is performed—the *Celery* is nubbled, and a vast number of slugs are destroyed. The lime, however, must not be applied hot, and it must be shaken carefully into the hearts of the plants, and not in coarse lumps. Let a continual succession of the forward *Endive* be tried for the salad-bowl. Continue tying-up autumn *Lettuce*. Pay general attention to thinning *Spinach*; that to stand the winter may be thinned to 6 inches apart from plant to plant. Sow *Radishes* in a raised bed in a warm situation; these will come in through November, and even up to Christmas with a slight covering occasionally. Remove decaying leaves from amongst crops of *Brussels Sprouts*, *Broccoli*, and similar vegetables, and trench them into the soil in some spare part of the garden that is set apart for early-spring crops. No summer that has occurred within my memory has made the advantages resulting from a system of high cultivation so strikingly apparent as the present. That part of the ground which was trenched two spits deep last autumn bore luxuriant and ample crops of *Strawberries*, while the part of the same garden which was simply dug one spit deep, with a hard and comparatively impervious bottom at the depth of about 9 inches, produced only a few scorched leaves and a very few wretched fruit. In this case manure and other circumstances were the same, except the depth to which the soil was trenched. What is true of *Strawberries* is also true of every other crop whether in the garden or the field.

FRUIT GARDEN.

Of all the operations necessary to promote bearing, the general stopping of fruit trees is, perhaps, the most necessary, yet the most neglected, when the trees are stripped of their leaves; whilst even by some they are neglected at the very period when the rivalry of contending shoots and the darkness occasioned by watery breastwood are so prejudicial to the welfare of the true bearing shoots or spurs. Hence, in the spring, we hear so many complaints of the trees blooming irregularly, "breaking blind," blossoms produced without pistils, &c. I would advise that at this period the trained trees be gone over once more, entirely removing all late growths except from the lower and inferior shoots on Peach and Nectarine trees. These may be kept growing as late as possible in order to encourage strength in those parts, and to equalise the sap in the ensuing year, by the enlargement of their capacities for its reception. Pears will be found to benefit much by this mode of procedure; indeed, the whole of the snags should be left by shortening-back the young spray in June, which is totally removed in the first week in September. Much earlier than this would not answer, for although it might not cause the true blossom-buds of next year to "push," it would cause them to elongate, thereby producing abortive blossoms, and malformations in the fruit. Late-growing Vines should always undergo the same process, at the same time removing every lateral that is shading the principal leaves. This treatment should be applied to Vines in-doors as well as on the open walls.

FLOWER GARDEN.

Every attention should be paid at this period to collecting seeds of popular flowers for mixed beds or masses next year. The *Petunias*, *Salvia patens*, *Pentstemons*, *Calceolarias*, the *Antirrhinums*, with a host of annuals and other plants may at this period be collected. Gardeners in general can scarcely be expected to save many seeds; those who have small gardens may, however, do much in this way. Some of the climbers also produce seeds, such as the *Tropæolums*, *Maurandyas*, the *Lophospermums*, &c. Let the planting of bulbs for very early work proceed directly. Borders or beds deficient in the number of *Snowdrops*, *Crocuses*, and *Narcissuses* should have some introduced. The main planting, however, may be reserved for the early part of November. A few of the earlier sorts of *Hyacinths* may also be planted, covering them 4 or 5 inches in depth, and surrounding the bulbs with sand.

GREENHOUSE AND CONSERVATORY.

Many of our summer favourites will now be going out of flower, if they are not already so, and their place must be studiously supplied with plants peculiar to the autumn months. *Brugmansias* and *Clerodendrons* make an admirable display at this period; some large specimens should be grown later every season for this purpose. They succeed admirably throughout the summer in any common vinery or Peach house, if duly supplied with water and kept perfectly free from insects. Let all large *Orange* trees, *Camellias*, and other large specimens belonging to such structures be brought under cover in good

time. Amongst climbers the *Stephanotis* and *Pergularia* grown on ornamental trellises show themselves peculiarly eligible to be introduced here on the decay of other flowers. The *Jasmines*, also, especially *Jasminum Sambac*, are valuable thus treated. They are to be had in flower on pot trellises continuously from May; the principal treatment consists in stopping every luxuriant shoot as soon as it is a few joints long. The *Francisceas* are very ornamental plants, and well adapted for those who have only one house. *Franciscea Hopeana*, although an old kind, is still very useful, and is, besides, very fragrant. The young rambling shoots should be constantly stopped; doing so will induce them to bloom freely and remain in a bushy state. Stout young *Mignonette* plants, potted immediately and kept under cutting treatment for a week or more, will flower well in November and December, when every little matter of this kind will be acceptable. The *Cyclamen hederifolium* is a pretty little pot plant for those whose space is limited; indeed, the whole family of *Cyclamens* are particularly ornamental and easy of cultivation. The *Linum trigynum* is a pretty winter flower, one or two should grace every collection. As before observed, continue daily to house everything likely to suffer from the autumn frosts.

STOVE.

Several of the *Dendrobiums*, *Aërides*, *Saccolabiums*, and *Vandas* will still make considerable growth in a high temperature with much moisture, but take care to increase the amount of sunlight. *Cattleyas* should not be encouraged to grow after this time if good blooms are required. Young specimens may, however, still be kept growing for the sake of size. *Stanhopeas* which have made robust growth should have the supply of water diminished, and have a lower temperature with less shading; those still growing may be watered freely.

COLD PITS AND FRAMES.

These should now be furnished with bulbs of the most approved kinds for forcing, Pinks in variety, particularly the *Anne Boleyn*, *Neapolitan* and *Russian Violets*, and sturdy young plants of *Wallflowers* in variety. *Mignonettes* should be thinned in due season. Ten-week Stocks should be sown for pricking into pots by the end of next month. *Cinerarias* should now be repotted, and *Calceolarias* parted, placed in 3-inch pots, and plunged close to the glass in some cinder ashes in a cold pit or frame.—W. KEANE.

DOINGS OF THE LAST WEEK.

WHAT a pity it is that fine sunny weather should ever do harm! It is so much more pleasant to move about when the air is dry and calm, and the sun bright but shaded by occasional clouds. Many felt this during the week when caught far from home, or obliged to remain under what shelter could be obtained during the heavy rains that have visited us, after similar accumulated vapours had been condensed and soaked the battlefields of France. Would not these dread battles, by the disturbance in the atmosphere by the discharge of artillery, have something to do, naturally speaking, with the free falling of the rain? We know how all our weather-glasses fell without any seeming cause at the last awful bombardment of Sebastopol. Some of our volunteers, who have got their fair soakings at Wimbledon, have half-seriously commented on what a good firing of cannon might do for us in such a dry season. Further evidence is wanted before we can set down as cause and effect what may after all be a mere coincidence. We were glad, however, to see the showers falling, as they have done so much to cleanse and invigorate all vegetation, to give a green colouring to our meadows, and to make our lawns like green carpets. The wind that reached more than an equinoctial gale on the night of the 8th and part of the 9th did considerable damage in breaking and scattering limbs and branches of trees, rendering the flower garden less lovely, and sending down lots of fruit far from being ripe. These, however, would suffer less from the fall, owing to the softening of the ground by the rain. A rising barometer seems to indicate that the wind and the rains will soon be over, or be more gentle.

KITCHEN GARDEN.

Almost everything is thriving. Brussels Sprouts, Borecole, and Broccoli seem to grow like magic, and all the more from the ground between the plants being stirred with a fork. As a class (and even our cottager gardeners, who often beat the professed gardeners in vegetables), we are not fully aware of the great advantage this stirring gives to free growth. The late-put-in small plants of all sorts of Greens, if they do not

become very large, will be fine cutting in the early spring months. By the means referred to last week, and followed by the nice showers, we find Cabbages and Cauliflowers are now almost entirely free of the fly which settled on them in clouds. We have two nice pieces of early Cabbages, growing well, for early cutting next year, and will ere long follow with the main quarter and younger plants, having removed the Onions on purpose. The Onions, though plentiful, are much smaller than usual, as they were never thoroughly moistened from the time they were above ground until they were pulled up when all growth was over. We always had a difficulty, treat them how we would, even bringing poverty of soil to our aid, in securing a good supply of pickling Onions, but there will be no want of picklers this year.

Cauliflower, instead of coming forked and sprouting, as it was forced to do in the dry hot weather, is now vigorous, and turning in with beautiful white heads, so useful for table in the autumn months. Our seedling Cauliflower intended for next spring is just fairly up, and we shall scatter a little charcoal dust among it, as it looks as if the rains had been heavy enough for the little plants. Having these too early is generally anything but an advantage, as Cauliflower plants are next to lost if they show any signs of forming a head before the plants have attained a good size. When the heads are forward in autumn they are apt to bolt in winter and spring, and thus prove worthless.

We have found, on the whole, no plan better for early cutting than placing a lot of these plants under hand-lights next month. We generally put nine under a hand-light, and thin to four or five in spring. We have tried pots, repotting and then planting out, and it is a good plan where room can be found in a cool house, an orchard house, cold pit, or frame from which rats and mice can be excluded; but on the whole our plants put out under hand-lights in autumn, and attended to in winter, generally beat all other competitors where no artificial heat was given. Once we were hard driven, rats having nearly cleared off our fine young plants in winter, and we sowed in heat, pricked out in gentle heat, then transplanted in an earth pit—such as we use for early Potatoes—with a little bottom heat, and covered at first with old sashes, straw frames, &c., and thus we obtained fine early gatherings, and the mischief the vermin did was never known at the dining-table; the additional trouble, however, was considerable. We have also had plants potted at the end of this month and treated with a little extra heat until they were strong, come in early; but on the whole, where nothing but the heat of the external atmosphere is available, we have a decided leaning, for the first crop, to planting out under hand-lights, or little wooden boxes with a moveable glass top. No doubt the French cloches would do equally well, but of these we have had no experience.

The dull dripping weather enabled us to plant out the last of our *Celery*; and as the plants were fine and strong, and had been pricked out rather thinly, they lifted with large balls full of roots, and the suckers being removed, they were planted in well-prepared beds, which, when finished, were little if at all below the general ground level. These, being well watered, have shown no signs of distress in the brightest sun, but are pushing their roots freely in their new quarters. We never planted out so much *Celery* so late, but it looks now as if planted in July. Circumstances must often regulate our practice. In such a season we never could have obtained water to keep the *Celery* in health if it had been turned out in beds and rows, but it was kept healthy with little water and shading by letting it remain rather thickly until the 5th inst., when the weather changed. Most of it has been planted three rows in a bed, but as a piece of Peas gave no sign of being near any longer, we had the ground cleared and 15-inch-wide shallow trenches made, with 2-feet spaces between, and there we planted in single rows, the soil with the dung added being quite up to the general level. This is often a great advantage in damp, drizzling winters, as damping and rotting the plants are avoided. These, being strong plants, will show little signs of the late planting by the first weeks in November.

We forgot to state, that though the Onion ground, after *Celery*, was well manured, yet we shall add a little rotten dung and a dressing from the rubbish-heap before half trenching the ground for the Cabbage crop—all the more essential when we generally allow these Cabbages to occupy the ground for eighteen months, that is all next summer, and through the winter until the following spring. In some of our earth pits which we use for bedding plants, we have lots of the Little Pixie Cabbage and the Early Elm Savoy hearting nicely, both

of which will come in before the earliest Coleworts, and as they will be liable to the attacks of depredators, we shall use them up before the cold weather sets in.

The dry weather, as in the case of early Potatoes, which never were finer, has made little impression on Carrots, Parsnips, and Beet, which we have rarely had finer. Later-sown Carrots have not done so well. We planted out lots of Lettuces and Endive to stand the winter, and sowed at the foot of walls to give them a chance. Hoed between the autumn-sown Spinach and Onions, and lest the autumn should be fine, and the Spinach become rather tender, we shall sow a few rows more, which will be useful in spring if the frost prove very severe.

Rubbish-heap.—Mentioning it above reminds us that in damp days we have had ours made up afresh, mixing a little littersy dung, and a sprinkling of rough salt with earth from pots, weeds, Cabbage stalks, &c., and covering it all over with earth, so that what escapes from the heating may be retained. We are often surprised from whence such a huge heap of scores of cartloads comes. If we had rich waters to spare, we would have added them, and also some loads of lime if to be had. Built up in layers, and cut down from top to bottom, the rubbish-heap thus formed and heated will be an excellent dressing to wheel on in the winter months. Cottagers would greatly add to their supply of manure if they never allowed weeds, Cabbage or Cauliflower stems, &c., to decay without being covered with earth.

FRUIT DEPARTMENT.

The wind has thrown down even from our dwarf trees many fruit far from being ripe, and, therefore, they will be more liable to shrivel before being used. Apples and Pears should in general be gathered before they are fully ripe, just when the pipe are about half coloured. They will thus be more juicy and have a richer flavour. Before this appears in type we shall have been using for three weeks in first-rate condition that fine autumn Pear, Williams's Don Christian, and that from one espalier tree bearing very fine fruit for the season. Such a Pear if allowed to hang until even nearly ripe, would not last many days. We have gathered the most forward, if not every day, at least every other day, and kept them two or three days before using them, just when full of their aromatic rich juice. The first we had we sweated a little in a little extra heat, covering them up to prevent the juice of the Pear escaping. Even when we give no extra heat, we prefer covering this rich Pear when gathered. We had a sample of small fruit of this Pear from a standard orchard tree, the possessor saying he had two or three bushels of it, and they all came in together. They could be of no use except for children, or those who liked a half-rotten Pear. They were as mealy as Potatoes, marked on the skin, and quite unfit to send to table. In some seasons, by careful picking, we have had this Pear in use for six weeks. If we had left it to itself it would not have been in use for more than six days. We mention this Pear merely as an example of what our amateurs might accomplish with favourite Pears and Apples—the Kerry Pippin Apple, for instance, and they can do far more than gardeners in general can find time and means to attend to. We have great faith in many improvements in gardening coming from and through enthusiastic amateurs. Even Peaches and Nectarines against walls were thrown off by the gale of the 9th and 10th. Perhaps what vexed us most was the number of fine fruit of the Reine Claude de Bavay Plum thrown from a bush tree, and these so green as not to be fit even for cooking. We expected them to be fine by the end of the month.

We alluded to orchard houses last week.

In late vinerias we are using a little fire heat to perfect the ripening, and keep a drier atmosphere. Ere long we shall, as the best we can do, throw some litter over the borders of the late house, especially to keep the heat in and the wet partially out, as the late rains have given pretty well enough of moisture.

ORNAMENTAL DEPARTMENT.

Taking plants under protection must now be thought about. The lawns are now beautifully green, and the flower beds stood the rains well until after the gale of the 9th. But for our bush-staking, our beds would have been nowhere. Large heads of scarlet Geraniums were nipped off and carried away scores or hundreds of yards. After all, a sunny day or two will make the beds very presentable again, though we hardly expect them to be so massive and rich as before the gale. That they suffered comparatively so little we attribute chiefly to two causes—first, the fastening the plants with small brauchy twigs; and se-

condly, having picked the beds over, so as to remove the faded blooms before the gale and the heaviest rains came. Even as it was, the rains dashed and discoloured many trusses of bloom, which will want picking or removing. Picking over a Geranium bed involves care and discrimination. Some pickers, if not looked over, if there are a few faded flowers in a Geranium truss, will forthwith cut it over and put it in their waste-basket, instead of neatly taking out the decayed flowers with the point of a sharp knife. The other day in such baskets we found trusses of Geraniums with from twenty to thirty small flowers only seeking room and time to expand and show their beauties. To cut off such where massive colouring is required is worse than carelessness.

All plants to flower in winter can now hardly have too much sunlight. Such fine plants as Euphorbia jacquiniiflora and Poinsettia pulcherrima, if full grown, should have less water and all the sun possible to set the flower buds. Sowed some hardy annuals to stand the winter, and a few, along with Mignonette, in pots to bloom early in spring. Proceeded with potting and cutting-making as previously detailed, propagating most of what will be wanted for the flower garden, except Calceolarias. Pricked off herbaceous Calceolarias for spring-blooming.—R. F.

TRADE CATALOGUES RECEIVED.

James Veitch & Sons, Royal Exotic Nursery, King's Road, Chelsea, London, S.W.—*Catalogue of Hyacinths and other Bulbous Roots.*

William Paul, Waltham Cross, London, N.—*Rose Catalogue, 1870-71.*

E. G. Henderson & Son, Wellington Road, St. John's Wood, London, N.W.—*Autumn Catalogue of Bulbs and Flower Roots.*

J. House, Eastgate Nursery, Peterborough.—*Select List of Hyacinths, Tulips, Crocuses, Narcissus, Gladiolus, and other Flower Roots.*

T. Binyard & Sons, Maidstone.—*Select List of Dutch Flower Roots.*

Butler, McCulloch, & Co.—*Catalogue of Dutch Bulbs, Flower, Vegetable, and Agricultural Seeds.*

TO CORRESPONDENTS.

* * * We request that no one will write privately to any of the correspondents of the "Journal of Horticulture, Cottage Gardener, and Country Gentleman." By doing so they are subjected to unjustifiable trouble and expense. All communications should therefore be addressed *solely* to *The Editors of the Journal of Horticulture, &c., 171, Fleet Street, London, E.C.*

We also request that correspondents will not mix up on the same sheet questions relating to Gardening and those on Poultry and Bee subjects, if they expect to get them answered promptly and conveniently, but write them on separate communications. Also never to send more than two or three questions at once.

N.B.—Many questions must remain unanswered until next week.

CUTTINGS OF RED-BERRIED ELDER (*North*).—We do not know where you can obtain them.

RIPE GRAPES SHRIVELLING (*West Cumberland*).—The berries you enclosed are dead ripe, and if the inside border is dry and the house heated the berries are likely to approach the raisin state. Watering and mulching the roots and a moist atmosphere we think would stop the shrivelling.

MISGAT OF ALEXANDRIA GRAPES SHRIVELLING (*Janah*).—We think that the reply we have given to "*West Cumberland*" is applicable to your case. If you mulch the border and water it in dry weather—in your case it is outside—and keep the air of the house moist, the Grapes will not shrivel, and those of the Lady Downe's be larger.

STEPHANOTIS FLORIBUNDA FRUITING (*F. L.*).—It is not unusual for it to ripen its fruit in this country. We have remarked more fully on the subject on page 397 of our last volume.

DESMODIUM RACEMOSUM.—J. V. wishes to know if anyone has seen this shrub in bloom, or whether it is marvellously good anywhere except in a trade catalogue. It is not a newly-discovered plant, for it is described by Thunberg among other Japanese plants.

DIAMOND PEACH.—This Peach is in the catalogue of Mrs. Pontey, of Plymouth, who, in answer to my inquiries, tells me the tree was raised from seed by Mr. Sharland, who was gardener at Werrington Park, near Launceston, about twenty years ago. The variety is well worthy of a notice in the "*Fruit Manual*."—V. W. POPHAM, *Portsmouth.*

SPOT ON MELONS (*Somerset*).—We are unable to account for the spot on the Melon, but as the fruit arrived at maturity the spot could not have been of material consequence. The leaves going off after the fruit is ripe is only natural, though sometimes by cutting back the shoots which have produced, fresh shoots will start and bear a second crop of fruit; but for this to be the case, the first crop of fruit must be ripe and cut early in July, so that the fresh shoots may be formed and fruit showing early in August. We think the plants are exhausted, hence their dying

off. The leaves are, no doubt, scorched through allowing the sun to shine powerfully on them whilst wet. To prevent it give a little air earlier in the day, and slight shading during very bright weather, especially when it is preceded by a period of dull weather. The thirteen fruit, some the size of walnuts, and others as large as ducks' eggs are early enough to ripen, but we should reduce the number at least one-half; indeed, four fruit on a plant are as many as we have found swell and ripen well. It is not sufficient that each fruit be on a separate tertiary shoot, but one fruit to each primary shoot is necessary to secure finely-swelled fruit. The temperature of 76° in the morning is too high by 1°, 65 being a very good temperature for Melons in the night when in a bearing state, and we think you have made some mistake. Perhaps the temperature of 76° is when you give air—8 A.M., or later. If so it is right.

LAUREL SCREEN FOR ROSES (F. J. K.).—The screen of Laurels to the north of your standard Roses will not injure the Rose trees unless they are so near as to interfere with the Rose roots by robbing the soil of nutriment, but if not nearer than 4 feet they will do no harm. We would keep the Laurels well cut back on the side next the Rose border, and their roots may be kept within bounds by taking out a trench about 2 feet from the stems of the Laurels, cutting off all roots there to the same depth as the Laurel roots are situated. This may be done in spring before they begin to grow.

PYRAMID APPLE AND PEAR TREES UNFRUITFUL (Idem).—There is nothing strange in your trees not fruiting. They have all gone to wood, and the height, 10 feet, indicates to us that summer pruning has been totally neglected. We advise you to take out at 2 feet from the stem a trench round each tree as soon as the leaves begin to fall, cutting off every root great or small, and whilst the trench is open cut with a spade under the ball towards the centre of the tree, severing every root at 15 inches beneath the surface. Fill up the trench, and prune when the leaves are all off, so as to form a well-shaped plant. If the ground is damp we would take up and replant each tree on a raised mound, or lift it with a ball, place it on the level, and put soil against the ball so as to form a cone twice as wide at the base as it is high. If the height be 18 inches the soil should slope away for 3 feet from the stem all round. Mulch with litter 2 or 3 inches thick to protect the roots from frost; they should not be covered more than 3 inches deep. This will check the growth. Whichever course you pursue it will have one result, preventing gross growth for the next two or three years at least; and by keeping the shoots pinched in summer, taking out the point of each when it has made six leaves, again at the second leaf from that, and then to one afterwards throughout the summer up to the middle of September, in the following year we think you will have fruit. There is no necessity to take up the trees and replant unless they have grown beyond bounds and are irreclaimable. We presume the Pears are on the Quince, and the Apples on the Paradise stock. Apples and Pears on these stocks are with us bearing heavy crops this year. Pyramid Plums are also loaded with fruit.

POND FOR GARDEN USE (Idem).—The pond for securing water for the garden in summer will be valuable. Its size will be entirely dependent on the extent of the garden. For ordinary purposes, by which we mean watering in dry weather, we should not have a pond less than 18 feet by 3 feet, and 6 feet deep, but twice that size would not be too large if you are entirely dependent on filling it during the winter months; but if you can command a supply with every fall of rain, then the size named would answer very well. Now, before rainy weather sets in, is the proper time to do this kind of work. The sides and bottom will need to be made watertight either by puddling with clay, or by walling it round, plastering with cement, and backing the wall up with clay rammed firm.

AZALEA LEAVES BROWNED (J. Clark).—The leaves appear to have been browned at the ends through allowing the sun to shine on them whilst wet, and they look as if water had stood on them almost constantly. One of the leaves has every appearance of having been infested with thrips. The remedy in the latter case is to fumigate with tobacco, and in the former not to syringe so heavily; indeed, at this time of year it is not necessary to syringe. Admit air freely. Surely something must be altogether wrong in the soil or the treatment, otherwise six plants out of ten would not have died. See to the drainage of the pots.

LUCCIA GRATISSIMA LEAVES FALLING (Subscriber, Dublin).—The leaf sent has the usual appearance when the roots of this plant are not in a healthy state. In a pot the plant's leaves always have a tendency to fall, especially when the pot is small. It is well, therefore, to place it in a large pot, or, better still, plant it out in a bed or border in a conservatory. Peat and loam in equal parts, both fibrous, and a fourth of charcoal in lumps between the size of peas and walnuts, with a sixth of silver sand, form a very good compost. Good drainage is necessary. Care should be taken not to overwater; indeed no water should be given as long as the leaves do not flag, but before they do this give a good watering. Watering constantly in dribblers is ruinous to it. The leaves attain but a small size and have a brown dingy appearance when the plant is kept deluged with water.

TACSONIA MOLLISSIMA NOT FLOWERING (Idem).—We cannot account for your plant not flowering, as you do not afford us any data. We have it planted out in a greenhouse border in a compost of equal parts of loam and leaf soil, with a free admixture of sharp sand. The shoots are trained about 14 inches from the glass, and from 3 to 6 inches apart; it has been in bloom since May, and is now finely in flower, having several fruits about the size of an egg. Water has been given as required to keep the leaves from flagging. That is all it has had or seems to require.

CAMELLIA POTTING (Idem).—Your plant with all its buds well set would, we think, swell them and flower all the better if it were left alone for the present, deferring the potting until the flowering is over. There is a risk of the buds falling if the potting is done now, though it may be performed now, care being taken not to injure the roots.

POTTING DRY BULBS OF LILIUUM AURATUM (An Amateur).—No Lilium ought to be kept out of the ground all the winter. If by dry you mean imported bulbs, put them at once in a compost of one-half fibrous loam, one-fourth sandy peat, and one-fourth leaf soil or old cow dung, with a free admixture of sharp sand. Drain the pots well, and pot so that a space of from 14 to 2 inches will be left below the rim for top-dressing in spring, or when the shoots are fairly above the rim of the pot. In potting cover all but the crown of the bulb. For dry bulbs place a little silver sand at the base of the bulb and all round it. After potting water gently, but not for some time if the soil be moist, and place the bulbs in a cold

pit or house secure from frost, watering but little, if at all, so long as the soil remains moist. When the shoots appear water more freely, and top-dress with the same compost as that used in potting, when the shoots are sufficiently advanced. When growth begins place the pots in a light, airy position, and as near as practicable to the glass to allow room for growth.

GATHERING MEDLARS (N. C. W.).—They will not be fit to gather for some time. They are usually not ripe until the leaves begin to fall; but when they put freely from the tree they should be gathered and stored in a single layer in a fruit-room, and all they require is to be looked over, taking out any that decay, and securing them as they ripen. No use of which we are aware can be made of the fruit now falling. If bruised it will not keep till mellow, but will decay prematurely. Medlars are not eaten until they have undergone incipient decay, and are then much relished by some. Of the grafting point we have no experience, but we do not see why it should not be kept in a vessel like any other point for occasional use.

VINES INJURED (E. J.).—No doubt the burning of the leaves by a fire in the house greatly injured the Vines, and the Grapes especially. Still, as the leaders that chiefly suffered made fresh leaves, we are doubtful if that would cause the berries to rot off now. We are inclined to think it must have been the result partly of a close damp atmosphere. The border having been made so recently, and the season so dry generally, we can hardly think the evil can be owing to too much moisture there. If it should be at all owing to the roots going down into a bad soil, we do not see how bricking-up the back of the border inside and the front of the border outside would arrest the evil. The roots, prevented spreading, would be more induced to go down. We would mulch the surface of the borders, and give the Vines a fair chance another year before disturbing the roots.

HEATING BY HOT WATER (Timber).—The top of your boiler must be lower than the lowest heating pipe in the house; if a foot or two lower still all the better. The boiler will be best placed at one end. Covering the pipes for bottom heat thinly with rubble will be the most economical. For early spring work 2-inch pipes below and two above will do. For winter work 4-inch pipes will be necessary, unless you can cover the glass in severe weather. For all particulars, see answer to another correspondent in the second column, page 121.

FRENCH MARIGOLDS (R. N.).—Very like many others, and not equal to the best now cultivated.

HEATING BY GAS (E. L. J.).—The plan will answer very well provided you have a little door for lighting the gas burners, and use burners in proportion to the size of the place to be heated. There will be little danger of a stout slate cracking. If all is made secure—that is, the slate and covering, no gas can escape into the house. Cocoa-nut refuse would be the cleanest. The bottom of the pit being almost close to the slate, you will succeed with seeds and propagating best by having small moveable glass sashes over the bed. Without top heat we do not think Brazilian Ferns will thrive in such a place in winter.

FUEL FOR HEATING GARDEN STRUCTURES (Mrs. P. A.).—It is difficult to advise you, because we are not decided ourselves as to what is most economical, without taking circumstances into consideration. No doubt those who recommend Welsh smelting coal as, though expensive, the cheapest in the end, have so far reason on their side, that this kind of coal is very strong, and gives out a great amount of heat. But when you come to have rapid changes of weather from cold to warmer, or you have a stoker or fireman who now and then puts on too large a fire of this strong coal—and to keep things right he must either open the furnace door that the cool air may play over the fire instead of under it, or take the fire partly out—in either case there will be a waste of this expensive fuel, this counteracting most, if not all, of its extra advantages. The amateur who attends to the fire himself will find it cheapest to use the best fuel. We do not think the possessor of several hothouses, who must employ others to do such work, will find the dearest fuel the cheapest. If fair fuel is used, if a mistake occurs there is not so much loss. As you refer to coke, it has a great advantage beyond mere economy—the little smoke it makes. We think, on the whole, coke would be the cheapest, but there should be hot coals used for lighting and adding a little at a time, nuts being small nodules of the best and middling coal freed from the more dusty matter. Such plants as Virginian Stocks, Candytufts, and Chinese Chrysanthemums will often bloom for a month or two after the Geraniums are injured by frost. Plants of Lamplights, Hollies, Cottonasters, and Snowberries turned out of pots would also look well; but for much flowering you must depend on Snowdrops and Crocuses.

STANDARD FRUIT TREES (Pomas).—You do not state what part of the country you live in, or what you chiefly want the fruit for, whether for table or kitchen. We shall place the first four as most useful for the table: Apples; Devonshire Quarrendin, Kerry Pippin, Cockle Pippin, Blenheim Pippin, Cellini, Emperor Alexander, Kentish Filbasket, Bedfordshire Foundling, Northern Greening, Pears; Citron des Carmes, Williams's Bon Christian, Louise Bonne of Jersey, Aston Town, Burré de Capiaumont, Bishop's Thump, Winter Nellis; Cathlic and Winter Franc Real for stewing. Plums; Green Gage, Purple Gage, Jelferson's, Kirke's, Orleans, Goliath, Washington, Victoria, Pond's Seedling. These are mostly arranged in the order of their ripening. All the Pears, except the last two, will do for table. Of Apples, Cellini would be between table and kitchen, as when good it comes in for both. The first four Plums are good for dessert and also for preserving. The Diamond and Damson are good for cooking and preserving. The best time to plant is as early as possible at the end of October or the beginning of November, as soon as the leaves change.

VINES AND VINE BORDERS (J. Jackson).—In raising the roots of Vines, begin by a deep trench at the extremities, and carefully pick out the roots of the Vines as you go, keeping them covered and moist, and replant again as soon as possible in sweet mellow loam, covering from 6 to 8 inches. Let the border be from 20 to 24 inches deep, and well drained. In such a case as yours, however, where the luncches are only getting smaller, we would do nothing of the kind. We would merely take a lighter crop for a year or two, fork away as much of the surface of the border as would not hurt the roots at all, and then surface with fresh soil with a sixth part of lime rubbish and a few bushels of hoiled broken bones. We come to this conclusion as you are so sure the border is not sodden or sour. In such dry summers as we have had, almost every outside border

would have been better of a good manure watering, especially if there was drainage.

COW DUNG FOR VINE BORDER (H. W.).—Cow dung is a good mulching for Vine borders when put on, not fresh, but dry and sweet. If that cannot be obtained, we would prefer horse droppings as fresh as you like. Cow dung, if fresh, is too close. It matters little when applied. A covering all summer would save watering considerably. After it has been on some time it is as well to rake it off, or scrape it off, and add fresh. There are various modes of making a loose gravel walk smooth. You might consolidate it with tar, so as to make your gravel walk into tar pavement, as described at page 165. You might gain the same object, as we did years ago in some cases, without all the trouble of heating, boiling, and mixing, by merely using enough of tar in its natural state to moisten the gravel, and then covering with fresh and rolling down, so that the surface should be just embedded. We would do this in one of two ways in such a case as yours. First, if we could obtain enough of fine sandy gravel for a surfacing, we would roll the present walk hard, place on it a layer of tar, say one-eighth of an inch thick, roll with a wet roller, apply the surfacing soon after, and roll again. If we could get no fresh gravel we would sift the best surface gravel, passing it through a half-inch sieve, tar what was left, and put the sifted surface on. We never could see much advantage in boiling tar. The tar will run and mix admirably without boiling. The simplest mode of making such a pebbly rough walk smooth is to collect a lot of clay, dry and riddle it, roll the walk, add a surfacing of the clay, which will fill the interstices, and then cover with a slight surfacing of rough sand to prevent any of the clay adhering to the feet. We have used thick clay water, or rather clay mud, for a similar purpose, but it requires more time. Such rough walks as you describe are unpleasant, but they are better than smooth walks that stick to the feet in damp weather; the sand-surfacing will prevent that.

PROFITABLE VEGETABLE CROP (Gardener's Friend).—Your ground may fallow for two years will be suitable for most kinds of vegetables, and we think, all things considered, that Potatoes are most likely to repay you. The ground should be manured now, or between now and November, and we would dig it well and deeply, and if the soil is stiff, throw it up in ridges for the winter, that frost may act on it. In February or dry, frosty weather—if such do not occur, then in dry weather—turn over the ground with a fork, level it, and when the ground is in good working order plant the Potatoes as soon after the middle of March as you can. Having manured in autumn, it is not necessary nor desirable to manure at planting. As to kinds, we can recommend two second early, ripening early, excellent both before and after they are ripe, and keeping late. They are Lapstone (a kidney) and Early Oxford (round), both first class croppers. Our Potatoes this year are a very fine crop, both in quantity and quality.

WINTERING GERANIUMS IN A POULTRY HOUSE (Idem).—We fear your chances of wintering bedding Geraniums in a poultry house are very small. Your best plan would be to take up the old plants, strip off every leaf, keep them in the sun for a few hours to dry, and then store them in your house in dry sand. They will need to have the root portion buried in the sand, as well as a portion of the stems, but the soft succulent parts ought not to be covered. You must give air every fine day, and in frosty weather protect with a covering of dry hay or other dry material, removing it when the weather is mild. In March you may place the plants in pots or boxes in sandy soil, and with light and air they will begin to grow, though they will be better of a frame and a gentle hobdab.

FRUIT TREES FOR A GARDEN (E. B.).—For the establishers, we think Apples and Pears are best. *Dessert Apples:* Early Red Margaret, Kerry Pippin, Cellini, Adams' Pearmain, Golden Pippin, Margil, Nonpareil, Ribston Pippin, Sykehouse Russet, Court of Wick, Keddleston Pippin, Cockle Pippin, Downton Pippin, Braddick's Nonpareil, Old Nonpareil, Cox's Orange Pippin, Wyken Pippin, and Pears' six Plate. *Kitchen Apples:* Cox's Pomona, Keswick Codlin, Lord Salfield, Alfriston, Bedfordshire Fording, Pamelow's Seedling, Beauty of Kent, Northern Greening, Norfolk Beefing, Blenheim Pippin, Kymor, and Winter Majestic. *Pears:* Beurre Giffard, Citron des Carmes, Fondante d'Automne, Comte de Lamy, Beurre de Capiaumont, Bergamotte Esperen, Louise Bonne de Jersey, Forelle, Marie Louise, Williams' Red Chretien, Thompson's Seckle, Napoleon, Haeon's Uncomparable, Beurre Rose, Beurre Diel, Jean de Witte, Glon Morecan, Ne plus Meuris, and Beurre de Ranee. These we have found answer well. If you wish for a stewing Pear, C'atillac will suit. We do not consider Plums so well on espaliers, as they do not readily submit to horizontal training. They are best grown as pyramids or bun-bush, and kinds that so succeed are July Green Gage, Orleans, Kirke's Jefferson, Golden Gage, and Cox's Golden Drop. *Cherries,* if wished for in the open garden, are best treated as pyramids, in which way they bear profusely. *Bisarran Napoleon, Black Eagle, Eton, Florence, Knight's Early Black, May Duke, and Late Duke, the Morello* being a very handsome and exceedingly prolific pyramid. The east wall we should devote to Plums, Pears, and Cherries. *Plums—Green Gage, Jefferson, Cox's Golden Drop, Pond's Seedling, Victoria, and Prince of Wales. Pears—Beurre Diel, Flemish Beauty, Pisse Colmar, Leon le Clerc, Marie Louise, Winter Ne plus Meuris, Glon Morecan, and Ne plus Meuris. Cherries—Early Purple Gage, May Duke, and Black Chreissan or Tartarian.* For the fence with a north aspect, Morello and Tradescant's Heart Cherries are the only fruit trees likely to succeed, but we have grown excellent Red, White, and Black Currants against such a fence, and have them now in fine condition.

EMPEROR STOCKS (A. Z.).—They are biennials, and sometimes of longer duration.

SCARBOROUGH LILY TREATMENT (C. R. H.).—From the description we think that is the common name of your plant, *Vallisneria spiralis*. Unless you wish for more plants, we would not divide the plant, for we do not think any bulbous plant can be effected with but a few bulbs in a pot. We have it now with from six to a dozen and more spikes in a single pot, and the effect is very fine. If you wish to have more plants, then you may divide it into as many parts as there are bulbs, and pot each separately, employing pots twice the diameter of the bulbs. As much soil and as many roots as possible should be secured with each bulb. Drain the pot well, using a compost of two-thirds fibrous loam, and one-third leaf soil or old cow dung, with a sixth of silver sand. Pot firmly, the soil being moderately dry, and with the neck of the bulb level with the rim of the pot, the bulb being covered that depth with soil. Set the pots in a greenhouse in a light airy position, and keep the soil moist at all seasons, but never very wet, though when the plant is growing freely abundant supplies of water should be given. In July and August give plenty of

light and air, with no more water than will keep the foliage fresh. It is a splendid plant, of very easy culture, and one of the most useful for autumn display, doing well as a window plant, and not suffering to any great extent when placed in rooms during its flowering period.

RICHARDIA ETHIOPIACA TREATMENT (W. N.).—It thrives in a rich, light, fibrous loam, and though requiring plenty of water when growing it needs good drainage. A small pot for the size of the plant is desirable. When it has done growing, or say from June, or if in a window from August, keep it dry, not giving water to any great extent for the next three months, and when the plant begins to grow again water it copiously, and when it is growing freely set the pot in a saucer of water, or in a window in May, June, and July, when its growth will be complete; then keep it dry three or four months, and water it again according to the fresh growth, increasing the quantity as the plant grows. A situation exposed to the full sun is necessary. In winter keep frost from it.

TROPICOLM TUBEROSUM and PENTAPHYLLUM FLOWERLESS (Idem).—The cause of their not flowering is no doubt the exposed situation, but as the soil is dry, that may have something to do with it. Try a mulching of leaf soil or well-decayed manure in autumn, and copious waterings in spring and early in summer. Train the shoots near the wall so as to give them the benefit of its warmth, syringing freely on the evenings of hot days.

EVERGREEN TREES FOR SCREEN ON A LIGHT SOIL (Idem).—No evergreen shrub will bear exposure without some other shelter, except Gorse. Both the single and double Gorse are very ornamental, and will stand any amount of exposure. *Pinus austriaca* is the best evergreen tree for shelter, and by planting it you may have all the hardy evergreen shrubs without fear. If you only wish for a screen, then we advise Holly or Yew, both of which are excellent, and you can cut them in as much as you desire. The latter is the best screen or hedge known.

CLIMBERS FOR A SOUTH-EAST WALL (Idem).—*Jasminum nudiflorum, Lonicera flexuosa, Clematis Fortunei, and C. Jackmanni* would answer very well on your wall, and so would *Ax-bone, Queen and Dundee Rambler* Roses, but you should manure the soil well, and if it is dry water well in summer. If you wish for evergreens, *Escallonia macrantha, Garrya elliptica, and Crataegus Pyracantha* will suit.

LARGE MELON (John Leslie). We know of no record of a Melon weighing 15 lbs. 10 ozs. What of the flavour? And what is it like in shape—netted or not, round or long, ribbed or not, and where did it originate? Large Melons, as a rule, are no better flavoured than Turnips, but we have known some persons eat and admire for its flavour an Orange Gourd weighing over a hundredweight. Is not your supposed Melon a Gourd?

WHITE SUBSTANCE ON BARK OF BEECH TREE (Rep. —).—The substance on the Beech tree is not a fungus, but the produce of a *Coccis*. It has, however, been described as a fungus by Fries under the name of *Psilonia nivea*.

INSECTS (C. C. E.).—The insect you have sent, said to devour wireworms, is itself a wireworm—Oat is, it is the larva of *Blater fulvipes*, or a closely allied species. It is distinguished from the true wireworm by having the extremity of the body ending in a point with two small incisions on each side. Nothing has been recorded of its precise habits, and it may possibly feed on other larvae, which is, however, at least doubtful. *A Constant Subscriber*. The Apple twig is badly infested with the too common woolly American blight (*Aphis lanigera*). The infested parts should be well washed with hot soft-soap suds with lime and foot mixed, forming a stiff solution, applied with a soft brush so as to cause it to enter the wounds of the bark. The Thorn twigs have swellings like galls with minute holes, but we can find no trace of insects within, and believe them to be a vegetable gout-like disease. The Oak leaves are covered with the Oak-spangles, which are real galls formed by *Cynips longipennis*.—I. O. W.

NAMES OF FRUITS (H. M. P.).—Both Plums are Guthrie's Golden. *E. C. Oakham*.—Your Plum is evidently a seedling which has not yet been named. *(D. X. Z.)*—*Van Mons' Red (C. Charrbon)*.—*Yellow Imperial (A. B. A)*.—Your Plum is McLoudlin. *(C. Charrbon)*.—We cannot identify either the Apples or the Plum. If the Apple is not named, Summer Ribston is very applicable. *(C. B. Ware, H. M.)*.—The Apple is certainly not Fine Apple Russet. Send it to Mr. Rivers, and he will probably be able to compare it with some in his collection.

NAMES OF PLANTS (T. S. Subscriber).—We cannot undertake to name a plant from even a green leaf, and you have sent a dead one. We require to see a flower. *(H. W.)*—What you call "the Toad-plant" is *Stapelia normalis*, or Regularly-spotted *Stapelia*. "*A Subscriber's*" plant is the common Hemp (*Cannabis sativa*), the specimen sent being female. It usually grows very much taller, but the circumstances it was placed under would induce it to be so dwarf. *(July)*.—1. *Nephrolepis exaltata*; 2. *Selaginella Braunii* (S. pubescens of gardens); 3. *Asplenium flaccidum*; 4. *Selaginella Kraussiana*, the S. tortuosus of gardens; 5. S. Martensii. *(S. W. Tongue)*.—We do not identify the Madeira creeper from the solitary leaf sent us; but should she succeed in blooming it, we would then gladly endeavour to assist her by naming it. We should consider a loamy soil, with sand, without any peat, as best fitted for it, together with greenhouse treatment. *(Chulcar Fallon)*.—A pretty Creeper, which we have not yet recognised.

POULTRY, BEE, AND PIGEON CHRONICLE.

KEEPING POULTRY AS A BUSINESS.

At a meeting of the New York Farmers' Club, in answer to an inquiry about keeping poultry on a large scale, Warren Leland, of the Metropolitan Hotel, New York, who raises chickens at his Highland Farm in Westchester Co., said: "I have found that for every hundred fowls one must give up at least an acre, but rough land is as good as any. Hens naturally love the bush, and I lop young trees, but leave a shred by which they live a year or more. These form hiding places and retreats for them.

In such places they prefer to lay. I have great success, and it depends on three or four rules, by observing which I believe one can make a good living by hens and Turkeys.

1. I give my fowls great range; eighteen acres belong to them exclusively. Then the broods have a range of another large lot, and the Turkeys go half a mile or more from the house. The eighteen acres of poultry yard are rough land of little use for tillage. It has a pond in it and many rocks, bushes, weeds, sandy places, ash heaps, lime, bones, grass, and a place which I plough to give them worms.

2. When a hen hatches, I take her box, throw out the straw and earth, let it be out in the sun and rain a few days, and give it a good coat of whitewash on both sides. In the winter, when very cold, I have an old stove in their house and keep the temperature above freezing. There is also an open fire-place where I build a fire in cold wet days. They dry themselves, and when the fire goes out there is a bed of ashes for them to wallow in. Summer and winter my hens have all the lime, ashes, and sand they want.

3. Another reason why I have such luck is because my poultry yards receive all the scraps from the Metropolitan Hotel. Egg-making is no easy work, and hens will not do much of it without high feed. They need just what a man who works requires—wheat, bread, and meat. Even when wheat costs 2 dol., a bushel I believe in it for feeding hens. As to breeds I prefer the Brahmans, Light and Dark. I change the cocks every spring, and a man on the farm has no other duty than to take care of my poultry. I often have at one time three thousand spring chickens.

HINCKLEY POULTRY SHOW.

The general arrangement of both the poultry and the Pigeons, in Turner's exhibition pens, under a very capacious tent, was all that could be desired, but a little mismanagement in the prize schedule, by which both cockerels and pullets were entitled to separate premiums, though exhibited together in the same pen, caused considerable confusion. This plan, however, will be rectified at future meetings. Some very excellent *Dorkings*, both Grey and White, which competed in the general class, were to be met with at Hinckley. Of White *Cochins*, the whole were of the highest merit; in fact, very rarely, if ever, have such excellent pens of this breed been on view at any public exhibition, as those that were successful. The *Brahmas* were not nearly so good as they should have been, and the majority of the *Game* fowls were sadly out of feather. Some extraordinarily good *Sebrit* *Bantams* were shown; and the collection of *Pigeons* was throughout especially praiseworthy. The weather being very fine there was a large concourse of spectators, who expressed themselves in terms of high approval.

DORKING.—1, E. Wood, Clapton, Thrapstone. 2, J. Choyce, Atherstone. **C**. W. H. SALT, Leicester. *Chickens*.—Prizes. R. Wood (Pullets and Cockerel). C. J. Watts, King's Heath, Birmingham (Pullets and Cockerel). **S**PARTERS.—1, M. Brown, Ab Kettleby, Melton Mowbray. 2, and Prize, J. Stephens, Walsall (Cockerel and Pullets). **C**OCCHIN CHINA.—1, J. Stephens. 2, H. C. Woodcock, Bearsly, Leicester. *Chickens*.—1, J. Stephens (Cockerel and *he* Pullets). Prize, H. C. Woodcock (Pullets). **W**HITE.—1, H. E. Emberlin, Oadby, Leicester. 2, no competition. *Chickens*.—Prizes. A. Williamson, Queenborough Hall, Leicester (Pullets and Cockerel). *he*, H. E. Emberlin (2). **B**RAHMA POULTRY.—*Chickens*.—Prize, J. Watts (Cockerel). Prize, H. C. Woodcock (Pullets). **G**AME.—1, F. Handley, Loughborough. 2, W. E. Oakley, Atherstone. *c*, W. H. Clare, Atherstone. *Chickens*.—Prize, Mrs. Milhouse, Hinckley (Pullets). Prize, W. E. Oakley (Cockerel). *he*, W. H. Clare (Pullet); W. E. Oakley, Atherstone (2) (Pullet). **H**AMBERGERS.—*Golden-spangled*.—1, J. Stephens. 2, H. E. Emberlin. *Silver-spangled*.—1, J. Choyce, Atherstone. 2, F. Handley, Loughborough. **B**ANTAMS (*clean-legged, any variety*)—1 and *c*, W. Draycott & Sons, Humberstone. 2, J. Watts. *Game*.—1 and Prize, F. Handley. 2, J. Stephens. *he*, S. Deacon, jun., Gundle. **D**UCKS.—*Aylesbury*.—1, J. Choyce. 2, H. E. Emberlin. *he*, S. Deacon, jun.; J. Choyce. *Rouen*.—1, W. Choyce, Siledon, Atherstone. 2, J. Watts. *he*, R. Wood. **T**RUFFYS (ANY VARIETY)—1 and 2, W. H. Johnson. **G**EESE.—1, A. Guy, Eaton, Grantham. 2 and *he*, J. Choyce. **E**XTRA STOCK.—*he*, W. H. Jackson (Houlan Fowls and Buenos Ayrean Ducks).

PIGEONS.

CARRIERS.—1, J. Watts. 2, J. Stephens. **T**URBITS.—1, J. Stephens. 2, W. Choyce, Sibson. *he*, F. H. Paget, Birstall, Leicester. **P**OUTERS.—1 and 2, J. Stephens. *he*, H. E. Emberlin. **F**ANTAILS.—1, J. Stephens. 2, J. Watts. *he*, F. H. Paget; W. Choyce; H. E. Emberlin. **M**AGPIES.—1, J. Stephens. 2 and *c*, W. Draycott & Son. **A**NY OTHER VARIETY.—1, F. H. Paget. 2, J. Stephens. *he*, F. H. Paget; W. Choyce; J. Stephens; W. Draycott & Son; J. Watts (3). *c*, J. Choyce; W. Draycott & Son.

RABBITS.—*Hawest*.—1, Withheld. 2, W. H. Jackson, Lutterworth. *Greatest length of ears*.—1, W. H. Jackson. 2, M. Foxwell, Hinckley.

Mr. Hewitt, of Sparkbrook, near Birmingham, officiated as Judge.

HENS TRESPASSING.—The steeping of corn in whiskey to catch hens which trespass is no bad idea. It brought to my mind a circumstance which occurred in my early days. A farmer complained to Mr. Beecher that his crows did a great deal of harm, and requested compensation. Mr. Beecher told him to impound. The farmer got good strong porter, and steeped wheat and laid it for the crows. When they got drunk he tied their claws with twine, and carried along his line of crows to Mr. Beecher, who with his visitors enjoyed the fun

very much, and I must add that the farmer was liberally and generously rewarded.—(*Irish Farmers' Gazette*)

ECCLESHILL POULTRY SHOW.

This, the third annual Show of the Ecclehill Society, was held on the 3rd inst., and in spite of all the difficulties against which the Committee had to contend, notably the want of time in which to obtain subscriptions and get up the Show, it was in almost all respects a complete success. The prize list for poultry had been remodelled, and instead of divisions for old and young poultry the two were thrown together, the prizes consequently doubled, and some additional classes made. The Pigeon prizes were also increased, and a cup given for the largest number of points brought some strong entries. The pens were on Turner's principle, and all the arrangements were very good. The stock shown both in the poultry and Pigeon classes was excellent in quality and good in numbers. More especially may this be said of the Pigeons, in which one class, Antwerps, consisted of no less than twenty-three entries, most of them of great merit.

GAME.—*Black-breasted and other Reds*.—Cup, E. Aykroyd, Ecclehill. 2, J. Hodgson, Bradford. *he*, W. Johnson, Idle. *Any other variety*.—1, E. Aykroyd. 2, H. C. & W. J. Mason, Drighlington. *he*, J. W. Thornton, Bradford. *Hen or Pullet*.—1, J. Preston, Alerton. 2, J. Jackson, Ecclehill. *he*, J. Hodgson; E. Aykroyd; J. Firth, Chatsworth. **S**PANISH (Black).—1, H. Beldon, Bingley. 2, J. Thresh, Bradford. **D**ORKINGS.—1 and 2, J. Stott, Healey. **C**OCCHIN CHINA.—1, H. Beldon. 2, E. Baxter. **B**RAHMA POULTRY.—1, J. Bailey, Earby. 2, H. Andrews. *he*, H. Beldon; M. Scott, Cote, Idle. **H**AMBERGERS.—*Silver-spangled*.—Cup, H. Beldon. 2, H. Pickles, jun., Earby. *he*, W. Bairstow. *Golden-spangled*.—1, H. Beldon. 2, J. Rollinson, Lindley. *he*, C. Holstead, Fearncliffe. *Silver-pencilled*.—1 and *he*, H. Pickles, jun. 2 and *c*, H. Beldon. *Golden-pencilled*.—1, J. Smith, Gilsted. 2, H. Beldon. *he*, J. Hough. **B**LACK.—1, H. Beldon. 2, H. W. Hingworth, Idle. *he*, H. Pickles, Jun., Alerton. **A**NY OTHER VARIETY.—1 and *he*, H. Beldon. 2, H. Beldon, Clayton. **G**AME BANTAMS.—*Brown Red*.—1, Steele, Halifax. 2, W. Entwistle, Westfield, Cleckheaton. *Any other Variety*.—1, J. Thornton, Idle. 2, Steele. **B**ANTAMS.—*Any other Variety*.—1, J. Waddington, Guseley. 2, H. Beldon. *he*, H. W. Hingworth. —Steele. *c*, W. Greaves, Bradford. **S**ELLING CLASS.—1, J. Thresh. 2, W. Johnson. *he*, H. Bealand; M. Scott; H. Beldon. **D**UCKS.—*Aylesbury and Rouen*.—2, J. Ward, Drighlington. *Any other Variety*.—2, A. Vint, Idle (Muscovy).

PIGEONS.

CARRIERS.—1, E. Horner. 2, H. Yardley, Birmingham. *he*, H. Yardley; E. Horner. **P**OUTERS OR CROPPERS.—1, E. Horner. 2, J. Hawley. *he*, J. Hawley; E. Horner; Robinson & Glen. **T**EMPLETS.—1 and 2, J. Hawley. *he*, H. Yardley (2). **O**WLS.—1, H. Yardley. 2 and *c*, J. Hawley. *he*, H. Yardley; W. Stanhope, Ecclehill. **T**URBITS.—1 and 2, W. Lund, Shipley. 2 and *he*, E. Horner. **A**NTWERPS.—1, J. Jackson. 2 and *c*, S. Smith, Idle. *he*, J. Hawley; W. S. Ingle; J. Chadwick, Windhill; A. Child, Apperley Bridge; W. Stanhope; W. Hall, Undercliffe; E. Horner; W. H. Mitchell, Moseley, Birmingham. **D**RACOONS.—1, W. Lund. 2, H. Yardley, Birmingham. *he*, J. Hawley; H. Yardley; C. Jowett, Idle; J. A. Collinson, Halifax; E. Horner. **F**ANTAILS.—1, H. Yardley. 2, E. Horner. *he*, J. Hawley; E. Horner. **J**ACOBS.—1 and 2, J. Hawley. *he*, E. Horner. **A**NY OTHER VARIETY.—1, J. Thresh, Bradford. 2, J. Cannan, Bradford. *he*, H. Yardley; S. Smith; E. Horner (2); Robinson & Glen. *c*, J. Jackson. **S**ELLING CLASS.—1, J. Hawley. 2, W. Lund. *he*, W. Stanhope; W. Lund; E. Horner. *c*, S. Smith.

RABBITS.—*Long eared*.—Point Cup, J. Hawley. 1, C. Dibb. 2, W. Ridd, Undercliffe. *Any other Variety*.—1, Master J. Hartley, Bowing. 2 and *he*, F. Monson.

JUDGES.—*Poultry, Pigeons, and Rabbits*: Mr. J. Thompson, South-oram; Mr. E. Smith, Middleton.

LEYBURN POULTRY SHOW.

This was held in connection with the Richmondshire Agricultural Society's Show, on the 7th inst. The following awards were made by the Judge, Mr. James Dixon, North Park, Clayton, Bradford.

GAME.—*Black-breast or other Reds*.—1 and 2, W. Bearpark, Ainderby Steeple. *Any other Variety*.—1, C. Oiler, Leyburn. 2, W. Bearpark. **D**ORKING.—*Any Variety*.—1, W. Bearpark. 2, Mrs. B. Pierson, Bedale Hall. **S**PANISH.—*Black*.—1, W. Bearpark. 2, Rev. J. G. Milner, Bellerby. **C**OCCHIN CHINA.—1 and 2, Rev. J. Robertson, Swinton. **P**OLISH.—1, W. Bearpark. 2, G. Wood, Hamburghs. *Golden-spangled*.—1, W. Bearpark. *Silver-spangled*.—1, Rev. J. G. Milner. *Golden-pencilled*.—1, W. Bearpark. 2, Miss B. Pierson. *Silver-pencilled*.—1, W. Bearpark. 2, Miss B. Pierson. **B**ANTAMS.—1, G. Carter, Bedale. 2, Rev. J. Robertson. **D**UCKS.—*Rouen*.—1 and *c*, Rev. J. G. Milner. 2 and *he*, Rev. J. Robertson. *Aylesbury*.—1, Rev. J. Robertson. 2, M. Richardson, Constable, Burton. *Any other Variety*.—1 and 2, Rev. J. G. Milner. **G**EESE.—1, M. Robinson

MORPETH POULTRY SHOW.

This was held on the 8th inst., and was decidedly an improvement upon last year's show, both as regards quality and the number of specimens exhibited. The *Game* fowls were very good, but the adults were mostly out of feather. The prize *Brahmas* were in full feather, and very nearly won the cup, which went to a very fine pen of *Spanish* in excellent condition; a pair of very promising chickens were shown in this class. *Hambergs* were very good considering the season. *Bantams* were of fine quality, especially the first-prize Black Red *Game* cockerel and pullet. *Ducks* were well shown, first-class Black East Indian ducklings winning in the "Variety class." The first prize in the Selling class was won by a grand pair of Brown Red *Game* chickens, which were soon claimed at the selling price, £1. In several of the classes birds of this year's hatching competed successfully with all others.

GAME.—*Black-breasted and other Reds*.—1, J. B. H. Steekbarn. 2, Nichol and Lindsay, Morpeth. *he*, G. Taylor, Steekbarn. *Any other Variety*.—1, G. Taylor. 2, Nichol & Lindsay. **C**OCK.—1, J. Robson, Belside. 2, Nichol & Lindsay. **C**OCCHIN CHINA (ANY VARIETY).—2, J. Woods, Netherburn. **B**RAHMA.—1 and 2, J. Stalker. **S**PANISH.—Cup, Gibson & Stalker, Woodhorn. 2 and *he*, Sanderson & Oliver. **H**AMBERGERS.—*Golden-spangled*.—1 and *he*, G. & W. Johnson, Choppington. 2, A. Tait, Morpeth. *Silver-spangled*.—1, C. Anstron,

Beidsie, 2. Stephenson & Cheyne, Cowpen Lane. *hc, G. & W. Johnson Gold or Silver-pencilled*.—1, R. Bell, 2. Master J. W. Schofield, Morpeth. *hc, Stephenson & Cheyne. ANY OTHER VARIETY EXCEPT BANTAMS*.—1, J. Brown and Co., Sunderland. 2, M. Byder, Monkwearmouth. **BANTAMS**.—*Game Black*.—1, *W. or of Red*.—1, 2. D. Dowdy, Sleekburn. *Game, Any other Variety*.—1 and 2. J. Ferry, Cowpen. *Any other Variety except Game*.—1, R. Lashley, Sleekburn. 2, Miss F. Wilson, Woodhorn Manor. **DUCKS**.—*Aylesbury*. 1, Miss F. Wilson. 2, J. O'Leary, Morpeth. *Rouen*.—1, Miss F. Wilson. 2, Miss Wilson. *hc, Miss Davie, Hepscott Red House. Any other Variety*.—1, Miss Schofield, Morpeth (Buenos Ayres). 2, Mrs. J. Salkeld, Bramwell (Buenos Ayres). *hc, Miss A. Wilson (Call). SELLING CLASS*.—1, J. Ball, 2. C. Armstrong. *hc, Spheniscus, Morpeth (various). Nqr FOR COMPETITION*.—*hc, F. E. Schofield, Morpeth (Buenos Ayres).*

JUDGE.—Mr. John Shorthose, Hartford Bridge, Cramlington.

CLEVELAND AGRICULTURAL SOCIETY'S SHOW.

THE Show of the Cleveland Agricultural Society was this year held at Guisborough, on the 8th inst. The railway communication is not of the most complete kind, and, in addition, the district is not densely populated; there were, consequently, fewer visitors than usually attend this Society's Show. It was held in Admiral Chaloner's grounds, in a most picturesque locality in front of the Priory, and shielded by woodlands on three sides, and by a hill on the fourth. A large marquee was devoted to the poultry, of which the classes were not numerous, but the entries were good.

Spanish were but poor, the *Dorkings* of good quality, and the *White Cochins* in the first-prize pen of extraordinary merit, although the Buifs were bad, and the Partridge and *Brahmas* but moderate. The first-prize *Red Game* were Black Reds of excellent style and form, and very close in flesh; and the second good Brown Red chickens. The *Duckings* were bad, but the single cocks compensated for them, a cockerel of good proportions gaining first honours. The *Bantams* were bad, but the winning-pens in all the *Hamborough* classes were first-rate; and in the "Variety class" was an extremely good pair of *Houdan* chickens. The *Aylesbury Ducks* were very good in beak, as also the *Rouens*, and the latter were also very large; and in the next class for *Ducks*, *Black East Indian*, splendid in plumage, were first, and domesticated *Wild Ducks* second. It is seldom we have seen such a display of *Geese*, both *Geese* and *goslings* being of remarkable size of frame and very good in plumage; of *Turkeys* there were some very large birds, and we noticed a great improvement in the size of the *Turkey* points, as compared with those shown last year.

There were not many *Rabbits*, but those shown were good.

SPANISH (Black).—1, W. G. Fardon, Driffield. 2, W. Bearpark, Ainderby Steeple, Northallerton. **DORKINGS**.—1, W. Bearpark. 2, O. A. Young, Driffield. **COCHINS** (White or Cream).—1, G. H. Proctor, Durham. 2, J. H. Brantwhite, Stockton-on-Tees. **WHITES**.—1, G. H. Proctor. 2, and *hc, G. H. Brantwhite, Northallerton. Partridge or Grouse*.—1, W. J. Stewart, Darlington. **BRAMA POOTRA**.—1, E. Corney, Whitby. 2, W. G. Fardon. **GAME**.—*Black-breasted or other Red*.—1, E. Aykroyd, Eecleshill. 2, W. Bearpark. *hc, P. Starry, Ormsby, Middlesbrough; T. Blackburn, jun., Great Brompton (2). Any other Variety*.—1, E. Aykroyd. 2, W. Bearpark. *Cock*.—1, T. Blackburn, jun. 2, J. Watson. *hc, E. Aykroyd; W. Gately, Hemlington. GAME BANTAMS*.—1, W. J. Stewart (Call). 2, E. Corney. 3, T. Blackburn, jun. **HAMBOROUGHS**.—*Golden-pencilled*.—1, W. Bearpark. 2, G. Holmes, Great Driffield. 3, R. A. White, Whitby. 3. *Burn, Whitby. Silver-pencilled*.—1, G. Holmes. 2, W. Bearpark. *Golden-spangled*.—1, W. G. Fardon. 2, G. Pounder, Kirby Moorside. *hc, G. Holmes. c, O. A. Young. Silvers-spangled*.—1, J. Best, Boroughbridge. 2, G. Holmes. **ANY OTHER VARIETY**.—1, Rev. J. G. Milner, Ellerby Vicarage, Leaburn. 2, W. Bearpark. **CROSS BRED**.—1, Mrs. Buffham, Saltburn-by-the-Sea. 2, J. W. Pease, Hutton Hall. *hc, G. Pounder. Deeds*.—1, W. G. Fardon. 2, T. Blackburn, jun. **HAUNTONS**.—1, O. A. Young. *Rouen*.—1 and 2, Rev. J. G. Milner. *hc, G. Pounder. Any other Variety*.—1, S. Barn, Whitby (Black East Indian). *hc, Rev. J. G. Milner. GESE*.—1, Rev. G. Hustler, Stillingfleet, York. 2, O. A. Young. *c, J. Storry. Stokesley; Mrs. Braithwaite, Stokesley. Goslings*.—1, Rev. G. Hustler. 2, J. Storry. *c, Mrs. Braithwaite. TURKEYS*.—1, J. Storry. 2, Mrs. Braithwaite. *hc, Rev. G. Hustler; G. Holmes. Point*.—1, Mrs. Buffham. 2, Mrs. Ward. *Black*.—1, W. G. Fardon. 2, O. A. Young. *hc, M. Harrison; Mrs. Reardon, Skutumpah Farm; J. Storry.*

RABBITS.—*Levath of Ear*.—1, T. Bousley, Egglecliffe, Yarm (Lop-eared). *Hearted*.—1, O. A. Young. *Fancy Bred*.—1, E. Bensley (Himalayas). 2, W. Elocote, Guisborough. *hc, J. Mudd, Newport, Middlesbrough.*

JUDGE.—Mr. E. Hutton, Pudsey, Leeds.

LEIGH POULTRY SHOW.

This Show was held on August 31st. The awards were as follow:—

GAME.—*Black-breasted Red*.—1, C. Chaloner, Whitwell, Chesterfield. 2, C. W. Brierley, Middleton. *Brown-breasted Red*.—1, C. W. Brierley. 1, T. Statter, jun. *Staud Hill, Whitefield. c, C. Chaloner. Any other Variety*.—1, C. Chaloner. 2, C. W. Brierley. **SPANISH** (Black).—1, C. W. Brierley. 2, N. Cook, Choumont. **CROSS-BRED**.—1 and 2, W. A. Taylor, Manchester. *hc, T. Pringle, Newcastle-on-Tyne. Any other Colour*.—1, J. Siebel, Timperley, Cheshire (White). 2 and *hc, W. A. Taylor. BRAHMA POOTRAS*.—1, J. H. Pickles, Birkdale, Southport. 2, W. A. Taylor. *hc, E. Leech, Rochdale. DORKINGS*.—1, J. H. Pickles, jun. (Silver). 2, C. W. Brierley. 3, W. A. Taylor. *hc, E. Leech, Rochdale. Partridge or Grouse*.—1, J. H. Pickles, jun. 2, T. Wrigley, Skipton. **HAMBOROUGHS**.—*Golden-pencilled*.—1, J. H. Pickles, jun. 2, T. Wrigley, jun. *Middleton. hc, H. Pickles, jun. c, S. Smith, Northwam, Halifax. Silver-pencilled*.—1 and 2, H. Pickles, jun. *Golden-spangled*.—1 and *hc, H. Pickles, jun. 2, D. Lord, Staekstead. c, N. Martin, Denton, near Manchester. Silvers-spangled*.—1, Cup and *hc, D. Lord. 1 and 2, H. Pickles, jun. Black*.—1, N. Cook. 2, N. Martin. **POLANDS** (Any variety).—1 and 2, H. Pickles, jun. (Silver). *hc, P. Unsworth, Loughton (2). c, W. Fearnley, Loughton (Silver). FRENCH FOWLS*.—1, J. H. Stott, Rochdale. 2, N. Cook. **BANTAMS**.—*Game*.—1, G. Auderton, Acornington (Black Red). 2, P. West, Abram. *hc, N. Cook. Any other Variety*.—1, J. H. Pickles. 2, S. & R. Ashton, Mottram (Black). *hc, N. Cook; J. Watts, King's Heath, Birmingham. ANY OTHER VARIETY*.—1 and 2, N. Cook, Bantams. **DUCKS**.—*Aylesbury*.—1, E. Leech. 2, J. H. Stott. *Rouen*.—1, Cup. 2, Gladstone, jun., Court Hoy, Liverpool. 1, J. Scotson, Little Eyreton. 2, Gannon, Chester. *hc, E. Leech; J. Scotson; T. Wakefield, Goolborne, Newton-on-Willows. Any other Variety*.—1, C. W. Brierley. 2, D. and W. Barton (Shell). *hc, R. & W. Barton (Call); J. Kilshall, Atherton Hall*

(Red-neck Divers); C. W. Brierley. **GESE**.—1 and 2, E. Leech. **TURKEYS**.—1, E. Leech. 2, J. Bent, Bradshawleach, Pennington. **SELLING CLASS**.—1, N. Cook. 2, W. A. Turner. 3, C. W. Brierley. *hc, P. Unsworth (Polands). 2. c, T. Wakefield, Loughton. EXTRA SROCK*.—*hc, N. Cook (Pheasants). hc, Miss A. Cook (Rabbit).*

SINGLE BIRDS.

GAME (any variety).—*Cock*.—1, J. Wood, Wigan. 2, J. Holland, Manchester. *hc, C. Chaloner. c, R. Southern, Leigh. Hen*.—1, T. Statter, jun. 2, C. W. Brierley. *hc, C. Chaloner. Cockerel*.—1, C. Chaloner. 2, J. Mason, St. John's Worcester. *hc, C. W. Brierley; J. & W. Wallas, Heaton. Pullet*.—1, C. W. Brierley. 2, J. Holland. *hc, W. Scotson, Bickershaw, Abram; J. Horne, Mouldon, Warrington (Brown Red); C. Chaloner. BANTAM* (any variety).—*Cock or Cockerel*.—1 and 2, A. Smith, Westleigh (Cockerels).

PIGEONS.

TROUBLERS.—1, J. Hawley, Bingley, Yorkshire. 2, F. Moore, Burnley. **CARRIERS**.—1, D. Bromiley, Over Hulton. 2, H. Yardley, Birmingham. *hc, W. Markland, Deane, Bolton. PICTURES*.—1, J. Hawley. 2, W. Gannon. **BARBS**.—1, H. Yardley. 2, D. Bromiley. **OVALS** (any variety).—1, D. Bromiley. 2, J. Hawley. **DRAGONS**.—1 and 2, J. Holland. *hc, D. Bromiley. hc, P. Unsworth; W. Markland. TROMPETERS*.—1, J. Hawley. 2, P. Unsworth. **FANTAILS**.—1, J. Hawley. 2, D. Bromiley. *hc, J. Kemp, Bolton. ANY OTHER VARIETY*.—1, J. Hawley. 2, J. Watts. *hc, H. Yardley. SELLING CLASS*.—1, J. Hawley. 2, J. Watts.

JUDGES.—*Poultry*: Mr. R. Teebay, Fulwood, Preston. *Pigeons*: Mr. Kidpath, Handforth Hall, near Willmslow, Cheshire.

TODMORDEN POULTRY SHOW.

THIS was held on the 10th inst. The birds were numerous and of first-class quality. The pens including old and young birds made it a difficult task for the Judge.

GAME.—1, C. W. Brierley, Middleton. 2, E. Aykroyd, Leeds. *Cock*.—1, C. W. Brierley. 2, F. Aykroyd. *Hen*.—1, B. Consterdine, Littleborough. 2, C. W. Brierley. **BANTAMS**.—1, J. H. Pickles, Birkdale, Southport. 2, F. Leech, Borchard, Cuckfield, Sussex. 3, T. H. Greenwood, Todmorden. 4, J. White, Wakefield. **BANTAMS**.—1, J. W. Morris, Rochdale (Silver-pencilled). 2, J. H. Pickles, Jaramose, *hc, S. & R. Ashton, Mottram. Game*.—1 and *hc, W. F. Entwistle, Cleekeath, 2, J. W. Morris, Rochdale. hc, Beilingham & Gill, Burnley. c, T. Baker, Burnley. DORKINGS*.—1, H. Pickles, jun. Early. 2 and *hc, J. Stott, Rochdale. SPANISH*.—1, W. Sutcliffe, Todmorden. 2, C. W. Brierley. **HAMBOROUGHS**.—*Golden-pencilled*.—1, H. Pickles, jun. 2 and *hc, T. Wrigley, jun. Middleton. Golden-spangled*.—1 and 2, H. Pickles, jun. *Silvers-spangled*.—1, H. Pickles, jun. 2, H. Pickles, jun. *Silver-pencilled*.—1 and 2, H. Pickles, jun. *Black*.—1, P. Lord. **ANY OTHER VARIETY**.—1 and 2, H. Pickles, jun. **SELLING CLASS**.—1, H. Pickles, jun. 2, S. Lord, Healey Hall Bottom, Rochdale. *c, T. Barker, Burnley. GESE*.—1, E. Leech, Rochdale. 2, S. H. Stott. **DUCKS**.—*Aylesbury*.—1, E. Leech. 2, S. H. Stott. *Buenos*.—1, E. Leech. 2, A. West, Worthorne, Burnley. *hc, S. H. Stott. Any other Variety*.—1, T. C. Harrison, Hull. 2, S. & R. Ashton. **TURKEYS**.—1, E. Leech. 2, J. Sykes, Shroctat, Halifax.

Mr. Robert Payne, of Brierfield, Burnley, is the Judge.

COTTINGHAM POULTRY SHOW.

COTTINGHAM, one of the most beautiful villages of the East Riding of Yorkshire, held its poultry Show on the 9th inst., in a small but well-wooded park. The entries were numerous, and in some of the classes the birds were good. The *Spanish* were exceedingly fine, especially the first-prize pen, but the *Cochins* and *Dackings* were only of moderate quality. The first-prize *Red Game* were Brown, and the second *Black Red*. The former were out of condition to some extent, but the hen in the latter pen was bad in colour of plumage and eye. *Dackings* were first in the Variety class, and the extra prize for the best pen was awarded them. The *Pullets* were uncommonly fine, *Silvers* being first and *Blacks* second; and the first-prize *Silver cock* was also extremely good. The *Hamboroughs* were of moderate quality, and the entries good; and in the class for *Farmyard crosses* there were some remarkably heavy birds. In the *Selling* class an unusually good pen of *Spanish* was shown, and quickly appropriated, the cock being superior to the first prize bird in the *Spanish* class. The *Bantams* were all exceedingly good, with the exception of the *Game*, which were very poor. There were some large-framed *Geese* and excellent *Ducks*.

The competition with *Pigeons* was keen in all classes, and the quality much finer than we expected to find. The first-prize *Pouters* were *White*, very good in thigh and feather. The second prize went to *Reds*. The *Carriers*, though a little coarse, were very long and well developed. The first prize *Turbits* were *Blue*, and the second *Red*. No class contained birds of higher quality than the *Dragoons*, though some were rather old for the show pen. The *Atmonds* shown by Mr. Adams were an exquisite pair in all points, and an exceedingly good match in colour and marking; the *Nuns* were also very good. In the "Variety class" *White Owls* were first, and *Black Magpies* second. The *Rabbits* made but a moderate display. For the small amount awarded to *Cage Birds* there was a capital entry. The two winning birds in the first class were *Belgians*, and in the next the first was a handsome light *Goldfinch Mule*, and the second a *Marked Canary*; and the winner of the new cage was a good *Jonque Lizard*, though rather flecked with white.

SPANISH.—1, T. C. & E. Newbitt. 2, W. G. Pinder, Driffield. *hc, J. Williamson, Cuck*.—1, G. Holmes. **DORKINGS**.—1, G. Holmes. 2, J. White. *Cock*.—1, J. Thompson. **COCHINS**.—1, F. Dawson, Beverly. *hc, Taylor; J. Dawson, Cuck*.—1, E. Cook. **GAME**.—*Red*.—1, G. Holmes. 2, W. Boyes. *Cock*.—1, W. G. Pinder. *hc, W. Boyes. Any other Variety*.—1, 2, and *hc, W. Boyes. hc, Mrs. Allans. Cock*.—1, W. Boyes. **POLANDS**.—1 and 2, Mrs. Proctor, Hull. *Cock*.—1, Mrs. Proctor. **HAMBOROUGHS**.—*Golden-spangled*.—1, G. Pinder. 2, Marnock. *Cock*.—1, G. Holmes. *Golden-pencilled*.—1, Chatter, Driffield. 2, G. Holmes. *Cock*.—1, G. Holmes. *Silvers-pencilled*.—1, G. Holmes. 2, Holly, Hull. *Cock*.—1, G. Pinder. *Silvers-pencilled*.—1, G. Liveridge. 2, G. Holmes. *hc, C. A. Harrison. Cock*.—1, G. Holmes. **FARMYARD CLASS**.—1, C. Goodby. 2, C. Hare, Cuck. 3, C. Goodby. **SELLING CLASS**.—1, T. and E. Newbitt. 2, T. C. Harrison. *hc, Lott; G. Holmes; C. Riley. Cock*.—

1,—Hague, Newland. *hc*, T. C. Harrison, Hull. VARIETY CLASS.—1,—Loft, 2.—Vawse. *hc*, T. C. Harrison; —Loft. BANTAMS.—*Gold-laced*.—1 and 2, T. C. Harrison. *Cock*.—1, T. C. Harrison. *Gamer*.—1,—Hardy, Hestle. 2.—R. W. Beverley. *hc*, H. Adams, Beverley. *hc*, C. Wilson, Driffield. *Cock*.—1,—Bingrose. *Any other variety*.—1 and *hc*, T. C. Harrison. 2, Messrs. Newhall. SPECIAL PRIZES.—1, G. Bromley. 2.—Chapoy. *hc*.—Loft. GREENS.—1, J. Harrison. 2, J. Jordan. DUCKS.—*Aylesbury*.—1 and 2, O. A. Young. *hc*.—Lawson. *Any other variety*.—1, Richardson. 2 and 3, T. C. Harrison. TURKEYS.—1, G. Holmes. 2.—Jordan.

PIGEONS.

POUTERS.—1, H. Adams. 2, G. Statter. CARRIERS.—1,—Campey, Beverley. 2, H. Yardley. TERRITS.—1,—Lawson. 2.—Richardson. *hc*, Whole class. TRUMPETERS.—1,—Marshall. 2.—Gillins. JACOBS.—1,—Sandors. 2, G. Statter. FANTAILS.—1, Davis & Thompson. 2, H. Yardley. TUMBLERS.—1 and 2, H. Adams. *hc*, H. Yardley. BARNS.—1,—Lawson. 2.—Richardson. NEWS.—1, T. Statter. 2.—Richardson. *hc*, H. Yardley; Davis & Thompson. ANY OTHER VARIETY.—1, H. Adams. 2 and *hc*, Mrs. Proctor, Hull.

CANARIES.—1, Miss Ellison. 2, G. Grant. *hc*, R. Redhead; —Lewis; —Petch. *Any other variety*.—1 and *hc*, —Petch. 2, R. Redhead. *For New Cage*.—1, G. Lewis, Hull. *hc*, C. Weddall.

RABBITS.—*Lop-eared*.—*Black*.—1,—Ashton, Hull. 2.—Turner, Hull. *Doc*.—1 and 2.—Ashton. *Any other variety*.—1,—Ashton. 2.—Lunn.

JUDGE.—Mr. E. Hutton, Pudsey, Leeds.

GREAT HORTON POULTRY SHOW.

THERE is scarcely a village in the West Riding of Yorkshire that has not its annual Poultry and Pigeon Show, and following the example of their neighbours, a few of the amateurs of this district brought together on the 10th inst. an excellent exhibition of stock, which was inspected by a great number of visitors. The *Gam*, with the exception of the first-prize Black Reds, were of poor quality. The *Hamburghs* were moderately good, and the *Polands* very fine; but the best class in the Show was the *Gamm Bantam*. In *Ducks*, the first prize was taken by Ruddy Shell, and the second by Rouens.

The *Pigeons* were tolerably numerous, and there were some good birds in all classes, although several pens of birds were disqualified; in the Antwerp class, for instance, two cocks were exhibited as a pair.

The entries of *Cage Birds* were not numerous, but there were some very fine specimens, notably of Norwich Canaries. The *Evenly Marked* were also very good, also the *Jonque Lizard*; the *Meales* were poor. We noticed a most handsome *Pied-bald Linnct Mule*, winner of the first prize for that variety, and both *Buff* and *Yellow Goldfinch Mules* were worthy of notice.

GAME.—*Cock*.—1, G. Naylor, Great Horton. 2, E. Jowett, Great Horton. *hc*, J. Hodgson, Bowling. *Any Variety besides Game*.—*Cock*.—1, H. Barker, Keighley. 2, J. Thresh, Bradford. *Black-breasted or other Bids*.—1, J. Preston, Alerton. 2, E. Jowett. *hc*, J. Hodgson. *Any other variety*.—1, G. Ambley, Queensbury. 2, J. Preston. HAMBURGS.—*Gold-spangled*.—1, J. Preston. 2, H. Bowker, Keighley. *Silver-spangled*.—1, H. Bowker. 2, T. Robinson, Harden. *hc*, T. Fawcett, Baildon; W. Bairdow, Bingley. *Gold-pencilled*.—1, J. Preston. 2, F. Steel, Halifax. *hc*, Clough & Jackson, Lister Hills. *Silver-pencilled*.—1, H. Bowker. 2, J. Preston. *Black*.—1, H. W. Illingworth, Idle. 2, T. Robinson. *hc*, Clough & Jackson. SPANISH (Black).—1 and 2, J. Thresh. CUCKINS-CHINAS.—1, J. Preston. 2, J. Dixon, Horton. *hc*, J. Rudd, Horton. DORINGS.—1, J. Preston. ANY OTHER VARIETY.—1, H. Bowker. 2, J. Preston. GAME BANTAMS.—*Any Variety*.—1, F. Steel. 2, J. Blamires. *hc*, F. Steel; J. Blamires; E. K. Fox, Great Horton (2). BANTAMS.—*Any other Variety*.—1, H. W. Illingworth. 2, J. Hodgson. *DIVERS*.—*Any Variety*.—1 and 2, J. Dixon, Horton. *hc*, Miss Bentley; H. Flather, Bowling.

PIGEONS.

CARRIERS.—1, H. Snowden, Horton. 2, J. Holden, Wibsey. CROPPERS.—1, J. Hawley, Bingley. 2, H. Snowden. *hc*, W. Whitaker, Horton. TEMPLETS.—1, J. Hawley. 2, Clayton & Barstow, Gillingham. JACOBS.—1, J. Hawley. 2, Clayton & Barstow. *hc*, J. Thompson, Bingley. BARNS.—1, J. Thresh. 2, J. Hawley, Bingley. *hc*, Clayton & Barstow. FANTAILS.—1, J. Hawley. 2, Clayton & Barstow. *hc*, J. Thompson. DRAGONS.—1, J. Holden. 2, Clayton & Barstow. *hc*, E. Jowett; Clayton & Barstow. TERRITS.—1 and 2, Clayton & Barstow. *hc*, J. Thompson. ANTWERPS.—1, Clayton & Barstow. 2, F. Steel. ANY OTHER VARIETY. 1, J. Hawley. 2, Clayton & Barstow. *hc*, H. Snowden; S. Heyworth, Dikirkh; M. Smith, Horton; J. Thompson; J. Thresh.

CAGE BIRDS.

NORWICH.—*Yellow*.—1 and 2, W. Heap, Bradford. *Clear Buff*.—1, W. Heap. 2, J. Wilkinson. *GREENS*.—*Clear Yellow*.—1, J. Wilkinson. 2, W. Heap. *Clear Buff*.—1, J. Wilkinson. 2, W. Heap. *Evenly-marked Yellow*.—1, S. Burton, Middlesbrough. 2, W. Heap, Bradford. *Evenly-marked Buff*.—1, J. Wilkinson. 2, S. Burton. LIZARDS.—*Yellow*.—1, R. Hotman. 2, J. Wilkinson. *Buff*.—1 and 2, J. Wilkinson. YORKSHIRE.—*Yellow*.—1, J. Wilkinson. 2, W. Heap. *Buff*.—1, J. Wilkinson. 2, M. Holroyd, Horton. ANY VARIETY.—1, J. Wilkinson. 2, J. Crossley, Great Horton. GOLDFINCH MULES.—*Evenly-marked Yellow*.—1 and 2, W. Heap. *Evenly-marked Buff*.—1, T. Hawman, Middlesbrough. 2, W. Heap. LINNET MULE.—1, W. Heap. 2, W. & C. Burniston, Middlesbrough.

RABBITS (Any Variety).—1, J. Evans, Queensbury. 2, F. Moulson, Little Horton. *hc*, H. Pool, Bradford.

JUDGES.—*Poultry and Pigeons*: Mr. E. Hutton, Pudsey, Leeds; and Mr. W. Cannan, Bradford. *Canaries*: Mr. James Taylor, Middlesbrough.

(From a Correspondent.)

THERE was not a large entry of birds, which I attribute to the Show not being properly advertised and its being the first attempt. Norwich Canaries were not so good as they are at some shows; the Belgians were very good, and will make a mark at any place they may go to. The competition of *Evenly-marked birds* was very close, and some of the best birds in the country were exhibited. Lizards were not up to the standard, except the first-prize Golden, and it was very evident that its journey had done it much harm, as it could not fairly draw itself together the whole day. Great credit is due to the Committee for the interest they took in this bird to bring it round; and should they have another show at Horton I would advise exhibitors to send them good entries, for I never saw birds better attended to. The *Yellow*

Yorkshire Canaries were noble, likewise the *Buff Yorkshire*. *Evenly-marked Goldfinch Males* were very good, and the prizes went to birds of no ordinary merit. *Linnet Mules* were only inferior specimens.

WHITBY CANARY SHOW.

This was held in the Congress Hall, Whitby, on the 13th inst. The following is the prize list, but we must defer further remarks till next week:—

NORWICH.—*Yellow*.—1, T. Irons, Northampton. 2, W. Barwell, Northampton. 3, J. Baines, York. *hc*, C. Burton, York; G. Gayton, Northampton. *Buff*.—1, R. Simpson, Whitby. 2, J. Adams. 3, T. Irons. *hc*, Moore & Wynne. *Evenly-marked Yellow*.—1, Moore & Wynne. 2, Adams. 3, J. Baines. *Evenly-marked Buff*.—1, J. Bexson. 2, G. Gayton. 3, T. Irons. *hc*, Moore and Wynne; J. Adams; W. Barwell. *Uncolorably-marked Yellow*.—1, J. Adams. 2, T. Irons. 3, C. Yeoman. *Uncolorably-marked Buff*.—1, Moore & Wynne. 2, W. Barwell. 3, T. Wales. *Green, Grey, or Buff-crested Yellow*.—1, T. Irons. 2, J. Bexson. 3, Moore & Wynne. *Green, Grey, or Buff-crested Buff*.—1 and 2, T. Irons. 3, J. Bexson. *hc*, W. Barwell; T. Irons. BURGUNDY.—*Yellow*.—1, J. N. Harrison. 2, T. Wales. 3, W. Bulmer. *Buff*.—1, W. Bulmer. 2, J. Bexson. 3, J. Barrett, Yorksire. *Yellow*.—1, T. Waindy, Norton. 2, Mrs. J. Wilkinson. *Whitby*.—1, C. Burton. *Buff*.—1, A. Webster. 2, Fairclough & Howe. 3, W. & C. Burniston. CRANVON.—*Yellow*.—1, T. Irons. 2, J. Bexson. 3, W. Bulmer. *Buff*.—1 and 2, T. Irons. 3, J. Bexson. LIZARD.—*Gold-spangled*.—1, J. Taylor. 2, J. N. Harrison. *hc*, J. Baines. *Silver-spangled*.—1, J. Baines. 2, J. N. Harrison. *hc*, T. Wales; J. Baines. CANARY.—*Green*.—1, G. Atkinson. 2, C. Burton. *hc*, Fairclough & Howe. BEEF.—1870.—1, R. Simpson. 2, Moore & Wynne. 3, R. Collinson. ANY OTHER VARIETY.—1, A. Webster. 2 and 3, M. Burton. GOLDFINCH MULE.—*Buff Marked*.—1, W. Handel. 2, C. Burton. 3, R. Hawman. *Dark*.—1, C. Burton. 2, J. Gray, Whitby.

PARROT.—1, Mrs. J. Wilkinson. 2, Mrs. J. Weighill.

LOCAL CLASSES.

NORWICH.—*Yellow or Buff*.—1, R. Simpson. 2, Mrs. J. McLaughlin & Brown. 3, H. Dale. *Yellow or Buff Marked*.—1 and 2, Mrs. J. Wilkinson. 3, T. Stewart. CANARY (Any other variety).—1, Mrs. J. Weighill (Clear Buff). 2, W. Henderson, Whitby (Crested Norwich). 3, M. Taylor (Cranvonn). MULE.—1, R. Corner, Whitby. 2 and 3, J. Gray.

BURGUNDY.—1, J. J. Haw. 2, W. Porritt. GOLDFINCH.—1, H. Dale. 2, T. Mcintosh.

JUDGE.—Mr. W. A. Blakston, Sunderland.

MANAGEMENT OF BIRD SHOWS.

As the time is fast drawing on when fanciers of cage birds will be busily engaged in sending their various specimens for exhibition, I should like, as one of the fraternity, to call the attention of committees and secretaries of bird shows to a few defects which may and do arise in their management. I was much amused the other day, if not a little vexed as well, on receiving my birds from a show (less than a hundred miles away) twenty-seven hours after it had closed. The birds were sent properly caged, enveloped in a wrapper, and well tied up with a strong cord. Thus packed they went as one parcel, booked through for Is. 3d. They were returned as two parcels, wretchedly packed, minus the cord, not booked through and the carriage was 2s. 10d. One of the best birds has since died from exposure. Now, if secretaries or their deputies would only take the trouble to observe how birds arrive packed, and return them in like manner, care being taken when unpacking that all cords, wrappers, &c., were systematically stowed away, I am sure we should hear fewer complaints from exhibitors. Secretaries must not imagine that because they receive no written complaints, on that account there is cause for none, and that none are made. I am well aware the duties of secretaries at such times are both "anxious and arduous," but exhibitors and their birds should receive the best of treatment from all show officials, and particularly those fanciers who do their utmost to uphold all well-regulated exhibitions by sending their specimens at no small risk, certainly at no pecuniary advantage. Few fanciers show their birds from motives of profit. There is an indescribable degree of interest and excitement in conjecturing beforehand what will be the position of such and such a bird, particularly so to the true fancier—he who breeds his own birds, and whether he will have the same rivals as last year, and what will be their relative positions. Such, I believe, are the feelings which move the majority of exhibitors.

Again, how much better it would be if secretaries would distinctly state when specimens will be returned; for fanciers residing some miles from a railway station, and beyond the limits for delivery, may have a whole day or more wasted in fruitless journeys after them. Catalogues, I think, ought to be forwarded by the first post after the awards are made, time, of course, being allowed for marking them. Fanciers like to know as soon as possible, especially when they pay for it, what their birds have done, and surely there is nothing unreasonable or impossible in expecting a catalogue twenty-four hours after the judge has made his decisions. Secretaries, too, and this is a matter of the greatest importance, should give strict injunctions to have all birds booked through if possible. This

not only reduces the charge for carriage very considerably, but, what is of far more consequence, enables birds to reach their destination much earlier than they could possibly do if they had to be dragged out at some intermediate station to be re-booked and await the arrival of the next train—frequently some hours. It is true the booking of parcels is generally done by lads who, either not knowing or not caring to ascertain to what places they can book through, despatch them to the next principal station, and leave them to reach their destination as best they may. This I have experienced over and over again, and it must stand to sense that if parcels can be booked through one way, say from Derby to Newcastle, it is only rational to expect to have them booked through from Newcastle to Derby. I am well aware that railway people are anything but obliging, but I think committees and secretaries of exhibitions of all kinds should do their utmost to enforce justice.

Another suggestion I would make is that Belgian and Lizard Canaries, usually shown in open wire cages, should be so placed in the exhibition-room as to be free from all draughts. They are naturally more delicate than the other varieties of the Canary, and, in order the better to protect them, a screen of calico or hunting, or any other material, might be advantageously erected. Belgians, generally placed first on the list, should during arbitration reverse their position, or be judged last, for this reason—they are birds which bear travelling but badly, and if judged shortly after being unpacked are frequently "rough" and unsteady. This arrangement would at any rate give them a little more time to compose themselves, and better display those peculiar characteristics which are so marked in the Belgian Canary, and on which their relative positions must depend.

A little more attention on the part of committees and secretaries generally would do much to encourage fanciers to send for exhibition specimens which they have hitherto deemed too valuable, and so tend to raise up more fanciers and exhibitors of that beautiful bird, the Canary, the keeping of which is a recreation that, if innocently pursued, is one of the most interesting and instructive.—JAMES N. HARRISON, *The Lawn, Belper, Derbyshire.*

THE NEW METHOD OF CONTROLLING THE FERTILISATION OF THE QUEEN BEE.

Some time ago there appeared in the columns of your valuable paper two or three communications, the purport of which was to give further enlightenment to the bee-master on the very important matter of queen-impregnation. This remarkable discovery hails from Yankeeland, and is quite equal to any of the big talk we are accustomed to hear almost any day from the same quarter. It has now for a long series of years been regarded as a settled fact amongst apiarists that the young queen not only leaves the hive, but that the contact is actually when she is on the wing; but according to our American cousins this may be accomplished by a different method, the *modus operandi* being to place the young princess along with a number of males in a small box or glass globe in which they are able to fly, not forgetting the necessary supplies, to shut them up, and in the course of forty-eight hours at the longest fecundation will have been secured.

At first when I read this new method I looked upon it with the gravest suspicion, and had very strong doubts regarding the practicability of a thing so far from the natural instincts of our little favourites, but which if true would be a valuable addition to apiarian science. A friend and myself, therefore, resolved to make the experiment and see if such could really be accomplished. Accordingly on a fine day about the beginning of the month (August), we opened a hive and removed from it a beautiful young Ligurian queen a number of days old, and which we were very anxious should meet with a pure mate, placed her in a box (certainly not smaller than those recommended), in company with a number of the opposite sex, shut them up, and allowed them to remain in this condition for twenty-four hours, at which time we had a survey and found her ladyship fine and lively, but the most of the drones dead, as we supposed from dashing themselves against the sides of the box, certainly not from any exhaustive cause. A fresh lot was added and allowed to remain for the same length of time with a like result. This, now, being all that was necessary and more than sufficient for us, we both pronounced it nothing short of Yankee bunkum. Chagrined, disheartened, yet not

altogether di-appointed, we returned our aspirant after regal honours to the home from which two days previously she had been rather unceremoniously removed, and on the next day to our great delight we saw her sally forth on what proved to be her wedding trip, and after a fifteen-minutes anxious watch saw her return safely, bearing unmistakable evidence that the object for which she had undertaken the journey had been accomplished. So far this is my experience, but should any other of your correspondents have tested the American statement, I shall be very glad to hear their opinion on the matter.—A STEWARTON APIARIAN.

I HAVE had my attention directed to two or three communications which appeared in the Journal regarding a "New Mode of Controlling the Fertilisation of the Queen Bee," a discovery stated to have been made by Mrs. E. S. Tapper, of Iowa, U.S., and corroborated, it appears, by others. If this were an established fact it would completely overthrow the whole views and findings of our best and most eminent bee-writers, and the discovery would be welcomed by practical apiarists as an inestimable boon, not only as respects the rearing and propagating of different varieties of the honey bee, but also in securing the fecundation of queens reared at seasons of the year when weather influences render such an event out of doors extremely hazardous and uncertain, if not impracticable.

From my own experience, however, on this subject, which extends over a considerable number of years, I never had any reason to doubt that the fecundation of the queen bee took place only in the open air. Indeed, there is no fact, I think, better attested in the natural history of the bee than this; and that although, in the language of Dr. Bevan, the queen were confined "amid a seraglio of males," yet a barren or abnormal queen she would ever remain. But we are told that by adopting either of the following methods we can control the fertilisation of the queen bee:—

1st, "Put the queen with the selected drones, and some honeycomb containing honey, in a box having a sliding cover and plenty of small gimlet holes through the top and sides for ventilation; remove the honey-board, and place the box on the frames, so that the queen and her companions may be kept warm; put on the cap, and leave them two or three days, and at the end of that time your queen will be purely fertilised."

2nd, "On the fifth day after the queen is hatched, or earlier if you choose (says Mr. Thomas in describing Mrs. Tapper's method), catch the queen and confine her with four or five select drones in a wire cage, with honey in the comb or in a sponge, and place the cage on the top of the nucleus or stock from which she has been taken, and let her remain from twenty-four to thirty-six hours, covering her up with the cap so that it will be quite dark. She will be fertilised, and commence to lay soon after being liberated."

3rd, Mr. Dux, of Güns, Hungary, confines along with the queen about one hundred bees. "The glazed box," he says, "is then darkened, and between the hours of eleven and three a drone is added, when you may watch their intercourse. If this does not occur on the first day, which, however, is generally the case, before three o'clock, it will take place the next day about the same time."

A Mr. Moore, of Ohio, however, has stated even a simpler process still. He has succeeded, he says, in getting queens fertilised "by confining them with a few drones under a wine-glass or tumbler placed in the sun; also by confining them in a lamp chimney, with the upper end stopped by a cork, and the lower end fitted into the feeding hole on the top of the hive, egress in this direction being prevented by means of wire cloth."

Mr. Woodbury, I observe, in alluding to the Hungarian method, thinks it a very feasible one, and far the most likely of any that has yet been devised to secure the end desired; but I must confess I am very sceptical as to any one of the plans succeeding. Let us consider the matter. In what respect do the circumstances in which the virgin queen is placed in the Hungarian method differ from those in which we experimental apiarists find her in our various operations a hundred times? Is it by reason of the queen being alone in company with the males that success attends the experiment? I fear not. I have more than once confined drones along with a queen under glass, and have witnessed nothing but mutual indifference and repugnance to each other; and intelligent apiarists are familiar with the case recorded by Huber, of his

having constructed a cubical glass box 8 feet high in connection with a hive containing a virgin queen. Her exit to the open air was prevented by a contracted entrance, but she had free access to the box by means of a glass tube, where she frequently betook herself every fine morning along with the drones; but though the experiment extended over fifteen days under a constant watch, yet no evidence was afforded of impregnation.

Again, is it because of the scantiness or paucity of the bees along with the queen that the desired object is attained? If so, why should not the same result follow in a hive where the bees, equally scant in numbers, have perfect freedom of exit? Such, at least, appears to me to be the logic of the case. But reasonings have no force in the face of facts. To the test, therefore, let us go.

It so happened that at the very time that Mr. Woodbury expressed his regret at being unable to experiment so late in the season, I had in my apiary two young queens in process of rearing. In one of the hives, a very large one, the bees were, from certain circumstances, reduced to two or three hundred. The queen remained, to my certain knowledge, unfecundated in this hive for several days, though of proper age, and in the society of males, the weather not permitting her to go abroad. But why was this if the fact be an accredited one, that the queen could be fecundated in the interior of the hive? The space was large, the population scanty, and no disturbing influences of any kind were present to prevent the desired object. But my experiment, perhaps, is defective. I must detach a still smaller number of bees, and confine them along with the queen, separating them by perforated zinc from the other moiety, and placing the prisoners over the hive in order to succeed. Well, I did so, and introduced, according to directions, selected drones to her majesty, and after two days' confinement allowed her and her associates to descend, but no evidence was forthcoming that she was fecundated. In the meantime the marauding bees began to pillage the hive and its scanty population offered but little resistance. I examined the interior occasionally, and now found the queen encased by the entrants and much injured. I immediately dissected her in order to set all doubts at rest, and found that a virgin queen she still remained.

Such being the result in this case, I did not submit the other queen to the like ordeal, as I might. Whether by repeated experiments a more favourable result would follow is another question; but in the case tested with every care and according to the directions prescribed, I find no evidence whatever of the truth of this new theory of queen-fecundation, and I here simply desire to record the fact.

The Köhler process I consider almost valueless and impracticable in this country.—J. LOWE.

THE HUNGARIAN METHOD OF CONTROLLING THE FERTILISATION OF THE QUEEN BEE—Mr. J. H. Thomas, the apianian editor of the *Toronto Globe*, after describing Mr. Dax's method of controlling the fertilisation of queens, says—"The above process, it will be seen, is very similar to the method already described in this Journal. We have experimented with one queen, and succeeded in getting her artificially impregnated."

OUR LETTER BOX.

WAKEFIELD SHOW.—We are informed that the Cochia chickens that won the cup are the property of Lady Burrell, and not of Mr. George Fletcher.

PROFIT FROM POULTRY-KEEPING (R. R.)—It is almost impossible to answer your question. To keep twenty-five fowls profitably you should have at least three-quarters of an acre, and part of it should be submitted to the landscape process we described some weeks since—that is, if chickens are to be reared. We cannot understand profit without breeding, except in some localities where new-laid eggs sell well. In such places fowls properly managed are very profitable, the eggs selling at 3d. or 4d. each, and often more. If you do not intend to breed you may keep twenty-five fowls well on a quarter of an acre. If you have not so much you may keep them on less, but when space diminishes profit-making must increase.

ROVEN DUCKS (J. Dove)—You are overfeeding your Ducks, and they are consequently most likely unwell from fat. Such a dietary as you name would only be excusable if you were feeding for exhibition where weight was the only merit. Give barley meal and a little Indian corn, but discontinue the sheep's entrails. Compel them to take a little exercise, and allow them a swim if possible. They will then most probably regain the use of all their members.

GUINEA PIGS.—Constant Reader wishes to know if any colour or kind is to be preferred of these unprofitable little animals.

DRIVING BEES (H. Marshall)—Bees will not quit their own well-furnished domicile for an empty or even a partially furnished hive merely because the former is capized and the latter placed over it. They require to be expelled by "driving," in the manner described in page 60, of the last edition of "Bee-keeping for the Many," which is now being reprinted.

ANTS IN DWELLING-HOUSE (I. L. T.)—Try sprinkling Scotch snuff in and around their haunts, and in the places which you especially desire them not to invade.

FLIES (B. C.)—We know of no mode of relieving a sitting-room from flies except opening the windows, driving them out by buffets with a handkerchief, and then closing the windows.

DRESSING RABBIT SKINS.—"W." will be glad to be informed the best way to preserve the skins of White Rabbits to be used for fur trimming.

METEOROLOGICAL OBSERVATIONS

In the Suburbs of London for the week ending September 13th.

DATE.	BAROMETER.		THERMOMETER.				Wind.	Rain.
			Air.		Earth.			
	Max.	Min.	Max.	Min.	1 ft.	2 ft.		
Wed. 7	29.429	29.386	58	44	58	57	S.	.26
Thurs. 8	29.662	29.490	67	46	59	57	W.	.20
Fri. 9	29.463	29.328	72	48	59	57	W.	.29
Sat. 10	29.930	29.541	70	34	62	56	W.	.00
Sun. 11	30.080	30.066	68	34	57	56	S.	.00
Mon. 12	30.083	29.995	67	42	57	55	W.	.00
Tues. 13	29.892	29.752	59	53	58	56	S.W.	.24
Mean.	29.792	29.651	65.86	43.00	58.57	56.28	..	0.90

- 7.—Overcast; heavy rain; showery; clear, starlight.
- 8.—Very fine; clear and very fine; rain at night.
- 9.—Overcast, strong wind; cloudy; clear and fine
- 10.—Boisterous; exceedingly boisterous; clear and fine.
- 11.—Very fine; fine, bright sunshine; clear.
- 12.—Very fine; cloudy but fine; clear and fine.
- 13.—Fine, but overcast; rain; fine and clear.

COVENT GARDEN MARKET.—SEPTEMBER 14.

CONTINUOUS heavy supplies of goods prevent any better prices from being obtained, and we find large consignments of French fruit coming to hand that, but for the war, would have found their way to Paris, all tending to glut the market. Peas now comprise Marie Louise, Louise Bonne, Bon Chrétien, and Beurre d'Annonis. The best varieties of Apples are Ribston Pippin, Downton Pippin, Ingestrie, and Kerry Pippin. Regents Potatoes, 9s. to 110s. per ton; Kidneys, 110s. to 120s. per ton.

FRUIT.

	s.	d.	s.	d.		s.	d.	s.	d.
Apples.....	1	0	0	0	Mulberries.....	lb.	0	0	0
Apricots.....	doz.	0	0	0	Nectarines.....	doz.	2	0	0
Chestnuts.....	bushel	0	0	0	Oranges.....	doz.	1	0	0
Cherries.....	lb.	0	6	0	Peaches.....	doz.	1	0	0
Currants.....	1/2 sieve	0	0	0	Pears, kitchen.....	doz.	0	0	0
Black.....	do.	0	0	0	Pears, dessert.....	doz.	1	0	0
Figs.....	doz.	0	6	0	Pine Apples.....	lb.	3	0	0
Filberts.....	lb.	0	9	1	Plums.....	1/2 sieve	1	6	0
Cobs.....	lb.	1	6	2	Quinces.....	doz.	0	0	0
Gooseberries.....	quart	0	0	0	Raspberries.....	lb.	0	0	0
Grapes, Hothouse.....	lb.	2	0	5	Raspberries.....	lb.	0	0	0
Lemons.....	1/2 100	10	0	0	Walnuts.....	bushel	10	0	0
Melons.....	each	1	0	4	do.....	1/2 100	1	0	0

VEGETABLES.

	s.	d.	s.	d.		s.	d.	s.	d.
Artichokes.....	doz.	0	0	0	Leeks.....	bunch	0	4	0
Asparagus.....	1/2 100	0	0	0	Lettuce.....	doz.	1	6	0
Beans, Kidney.....	1/2 sieve	4	0	0	Mushrooms.....	pottle	3	0	0
Broad.....	bushel	0	0	0	Mustard & Cress.....	pinnnet	0	2	0
Beet, Red.....	doz.	2	0	0	Onions.....	bushel	4	0	0
Broccoli.....	bundle	0	0	0	pickling.....	quart	0	4	0
Brussels Sprouts.....	1/2 sieve	0	0	0	Parsley.....	sieve	3	0	0
Cabbage.....	doz.	1	0	2	Parsnips.....	doz.	0	9	1
Capsicums.....	1/2 100	1	0	6	Peas.....	quart	0	0	0
Carrots.....	bunch	0	4	0	Potatoes.....	bushel	3	0	0
Cardflower.....	doz.	2	0	0	Kidney.....	do.	4	0	0
Celery.....	bundle	1	6	2	Radishes.....	doz. bunches	0	0	0
Coleworts.....	doz. bunches	3	0	0	Rhubarb.....	bundle	0	0	0
Cucumbers.....	each	0	6	1	Savoys.....	doz.	0	0	0
pickling.....	doz.	2	0	4	Sea-Kale.....	basket	0	0	0
Endive.....	doz.	2	0	0	Shallots.....	lb.	6	0	0
Fennel.....	bunch	0	8	0	Spinach.....	bushel	2	0	0
Garlic.....	lb.	0	8	0	Tomatoes.....	doz.	1	0	0
Herbs.....	bunch	0	8	0	Turnips.....	bunch	0	6	0
Horseradish.....	bundle	3	0	5	Vegetable Marrows.....	doz.	2	0	0

POULTRY MARKET.—SEPTEMBER 14.

THE only alteration we have to note is the beginning of the regular season for Partridges. If the hatch was satisfactory, there has been great mortality. We find a dozen old for one young. Trade is dull for everything.

	s.	d.	s.	d.		s.	d.	s.	d.
Large Fowls.....	2	6	8	0	Pigeons.....	0	8	0	0
Smaller ditto.....	2	0	2	6	Rabbits.....	1	4	1	6
Chickens.....	1	9	2	0	Wild ditto.....	0	9	0	10
Ducks.....	2	0	2	6	Hares.....	0	0	0	0
Geese.....	6	0	6	6	Partridges.....	1	4	1	6
Turkeys.....	0	0	0	0	Grouse.....	2	6	3	0

WEEKLY CALENDAR.

Day of Month	Day of Week.	SEPTEMBER 22—28, 1870.	Average Temperature near London.			Rain in last 48 years.	Sun Rises.		Sun Sets.		Moon Rises.		Moon Sets.		Moon's Age.	Clock after Sun.	Day of Year.	
			Day.	Night.	Mean.	Days.	m.	h.	m.	h.	m.	h.	m.	h.	Days.	m.		h.
22	Th	Length of night 11h. 48m. 15 SUNDAY AFTER TRINITY.	66.4	44.7	55.6	21	46	af 5	58	af 5	40	af 1	11	af 5	27	7	18	265
23	F		66.3	45.7	55.9	22	48	5	56	5	56	2	38	5	28	7	39	266
24	S		66.1	45.5	54.8	19	49	5	54	5	19	4	3	6	29	8	0	267
25	SUN		65.8	43.1	54.4	21	51	5	52	5	42	5	27	6	30	8	20	268
26	M		65.7	43.8	54.7	21	53	5	50	5	6	7	49	6	31	8	40	269
27	Tu		65.3	44.6	55.0	24	55	5	47	5	31	8	15	7	32	9	0	270
28	W		65.1	44.0	54.5	22	56	5	45	5	55	9	42	7	33	9	20	271

From observations taken near London during the last forty-three years, the average day temperature of the week is 65° 8', and its night temperature 44.2°. The greatest heat was 82°, on the 25th, 1832; and the lowest cold 23°, on the 25th, 1856. The greatest fall of rain was 1.68 inch.

THE GREENHOUSE OF ONE HAVING A SMALL INCOME.—No. 1.



HOUGH my income is rather limited (not over £100 per annum), it was my good fortune about four years ago to become the possessor of a small span-roofed greenhouse, and I wish to tell the readers of this Journal how I stocked it with plants, and how I grew them. At that time I was not a reader of this nor of any other horticultural paper, and hence did not know of the existence of Editors who would answer any question you

proposed to them in regard to stocking a greenhouse. But supposing I had known of their existence, and supposing they had given me such a list of greenhouse plants as they have given to other inquirers, I would have had to say, after consulting the priced catalogue of greenhouse plants which I kept constantly near me, "I cannot afford to purchase them, and hence must content myself with an empty greenhouse." But I quite meant to stock it, and hence resolved on availing myself of the resources I had at command.

Well, I had a few Heliotropes, Verbenas, Fuchsias, and Pelargoniums growing in a frame, and these I transferred to my greenhouse, intending some day to supersede them with plants which rejoiced in much longer names; but I have never done so, and never mean to do so. I admit that I have added a few plants whose names were as long as their price, but with one exception, to be afterwards noted, they have never come to occupy such a prominent place in my collection as their old-fashioned brethren.

In enumerating my original collection of plants I made mention first of all of Heliotropes. If I recollect rightly, the first plant to grace the stage of my greenhouse was a Heliotrope, and while I have a greenhouse I shall always give a prominent place to this, my favourite flower. Since I have had a greenhouse it has been to me a source of considerable pleasure to visit other greenhouses and compare notes, and I have often been surprised to find how very few people grow the Heliotrope. Indeed, with the exception of my own and a few other greenhouses in the neighbourhood, I have never seen Heliotropes grown to such a state of perfection as they are capable of. The plants which I grew and flowered in my greenhouse this year were three years of age. They were 5 feet in height, were grown in the form of a pyramid, and were clothed from top to bottom with handsome dark green foliage and fine trusses of lilac flowers, contrasting beautifully with their gayer neighbours the Fuchsias and Pelargoniums. The only difficulty which I have experienced in growing old plants of the Heliotrope was to get them to break freely in the spring, but I have no longer any difficulty in this direction.

The manner in which I grow them is as follows:—In the spring I select several of the strongest autumn-struck cuttings, and pot them off in rich soil, giving them the benefit of the bottom heat of any frame which I may have in operation. In a few days they commence to grow vigorously,

after which I carefully stake up the main stem, and pinch in the lateral branches. In a month they are ready to be repotted. I then give them a 6 or a 7-inch pot, and soil consisting of three parts rich turfy loam and one part good rotten manure, with the addition of a little silver sand, and replunge them. When they have again begun to grow I take them to the greenhouse, and give them the place which they are to occupy during the summer, taking care never to let them suffer from want of water, for I know no plants which suffer more owing to neglect in this direction. If they are carefully attended to and nourished with frequent applications of weak liquid manure, they will grow and bloom abundantly during the summer and up to the end of August. At that time I take them out of the greenhouse, and lay the pots on their broadside, withholding water from them. A week or ten days will suffice to ripen the wood and strip the leaves off them, after which I replace them in the greenhouse, taking out the old stake and replacing it with a longer and stronger one, to which I tie the main stem as well as the lateral branches. And herein lies the secret of successful growth—I used to cut off the laterals, and treat the plants as Fuchsias, but they would not break so freely as I could wish, and hence in several places the bare brown stem was conspicuous, detracting from the beauty of the plant; but since I began to tie up the laterals close to the main stem all difficulty has vanished, for the laterals break quite freely.

By the end of September the plants begin to throw out side shoots, which will increase to an inch in length before the growth is suspended. All that they require during the winter is a little water occasionally, and to be kept free from frost. In March give them quite a liberal shift. Let the pots be at least 10 inches in diameter, and the soil as formerly recommended, with the addition of half a handful of dissolved bones above the drainage of the pot. It is not easy to reproduce the fine dark shade of green in the foliage of plants grown in-doors which you will find in plants grown out of doors in rich soil. But the bones, with the rich soil, abundance of pot-room, and liberal supplies of liquid manure will work wonders.

Another point to be attended to is the regular pinching-in of the side shoots until you have succeeded in making compact bushy plants, after which they may be allowed to flower.

I hardly know anything finer than a well-grown Heliotrope. What a delicious odour the flower emits, and how finely it contrasts with other plants! In my greenhouse this year I had four plants of the dimensions formerly described, two of these being Reine d'Hiver, and the other two Miss Nightingale. Reine d'Hiver is a very fine Heliotrope either for greenhouse culture or for outside decoration. In colour its flower is of a rich violet with a yellow centre, and the plant is a most abundant flowerer. It is far superior to the old peruvianum and Voltaireanum. There may be finer varieties in cultivation now. Indeed, in your answers to correspondents, you speak of a Beauty of the Boudoir as being the best in cultivation; and really, if it is much finer than my favourite, I should like to make its acquaintance. However, no one need be in difficulties in

regard to acquiring a stock of *Heliotropes*. I see from some of the catalogues that half a dozen cuttings of the best varieties will be sent for a dozen stamps, and half a dozen is a large enough stock for any greenhouse. I am satisfied that to inexperienced amateurs, such as I am, a shilling's worth of *Heliotropes* will afford as much pleasure as a pound's worth of plants of a rarer kind; not that I mean to disparage the latter, but when cuttings of *Heliotropes* and other plants are to be obtained at such a cheap rate, no one need be at a loss in regard to stocking a greenhouse.

It will be at once apparent that I am writing for the encouragement of amateurs as poor as myself, but who do not happen to have as much experience—not that I have much. Indeed, I am not without my fears that your learned readers may be shocked by some things which appear in my paper. I can only say, I am not learned, but am learning, and hope some day to be able to entertain a more highly educated class of your readers than I am addressing at present.—H. S.

PLANTS FOR BASKETS AND VASES.

(Concluded from page 198.)

TROPÆOLUMS.—After trying a great number of varieties, including a fair proportion of seedlings, I am sorry I cannot give them such a good character as I should like. That they flower abundantly cannot be denied, and even the varieties whose principal fault when grown in the open ground is the great length of their leafstalks hiding or concealing so much of the flower, are not objectionable in the vase; but the trailing *Tropæolums* never seem to me to be at home in such a place; the long dangling shoots are few in number, and hang in anything but a graceful manner, struggling to move up and catch hold of something for support, and every wind tosses them about in a manner that soon renders them the reverse of beautiful. The place for a trailing *Tropæolum* is where it can cling to something for support, and ramble over roots or amongst branches, instead of hanging in mid air. The dwarfier varieties, however, are more at home in vases; they flower, perhaps, more abundantly than when in the open ground, and the habit is all that can be desired. Perhaps a few short branching sticks put in amongst them may help to secure them against high winds where much exposed, for they are not very strong at the neck, but in general their compact growth renders them easily managed, and nothing can exceed their abundant blooming. The yellow varieties, perhaps, exceed the scarlet in this respect, and certainly they are more useful, as yellow-flowered vase plants are the less plentiful; but there are some dark-coloured varieties as well, and many intermediate shades. A good white *Tropæolum* would be valuable; perhaps there may be one, but I have not seen it.

CUPREA PLATYCENTRA.—Differing widely from the above is this plant, which I would not recommend as a competitor to the *Geranium* in every place, but where there is a vase in a shady situation it comes in very well; it is also good late in the season, flowering during the autumn until a nipping frost cuts it off, but rain does not seem to injure it. Its spreading habit renders it suitable for occupying a vase by itself without the accompaniment of other plants, but I have known a white-flowered Ivy-leaved *Geranium* look well when employed as an edging to it, and the plant next mentioned is also well suited for the same purpose.

ARCTOTIS REPENS.—This has never become so popular for bedding as it deserves to be, but as an edging to other plants in a vase or basket it is valuable. Its beautifully frosted stems and foliage differ widely from those of ordinary pendent plants; indeed, its growth shows but little indication of hanging, as it extends horizontally from the edge of the vase, forming a sort of frame or guard to the centre, in the same manner as the guard petals of the *Anemone* or *Hollyhock*. Without pruning or training it gives a star-like outline to the vase, setting off to advantage a cluster of scarlet or other dark-flowered *Geraniums*. It may be used with advantage as an edging to most plants having green or dark-coloured foliage. It is not hardy, although it will bear a considerable amount of cold. This *Arctotis* is easily propagated, for when lying on the ground every joint strikes root. As an edging, it requires but little trimming, excepting, perhaps, directing some of the wayward shoots, and picking off a few of the old leaves in the centre of the plant, which have a tendency to become brown during the summer months. This, however, is not always the case, and in the present season there seems to be less browning than

usual; indeed, I have never seen anything to complain of it as a vase plant on that account.

SEDUM FABARIA.—The sturdy habit of this plant, its glaucous foliage, and its free-flowering character, entitle it to mention as a vase plant, and its value is further enhanced by its being perfectly hardy, plants in vases having survived the winter and grown well. For very small vases, where only one plant can be employed, I do not know anything better than this; and in a larger vase, if edged with some other plant, it is also of great service, as it never has an untidy appearance. It is astonishing how large a plant of this will grow and flower in a small vase, requiring no support nor attention of any kind save watering; but even if this be neglected, the plant seems to bear neglect better than many of its class. The flowers are also numerous, and, though not bright, are elegant. There are some other species of *Sedum* resembling this in outward form, but not so well adapted for the purpose, but I have never been able to make much of the dwarfier or horizontal-growing kinds. *S. azoricum variegatum* is not so satisfactory, neither is *S. Sieboldi variegatum*, there not being sufficient clearness in the white colour of either; and *S. Kämpferi* is likewise only an inferior kind, while *S. glaucum* is more ornamental in winter, its extreme dwarfiness rendering it only useful for covering the ground. Other species are only suited for the same purpose.

PORTULACAS.—Bright, gay, and varied to a degree not equalled by any other plant, these highly-ornamental annuals are, nevertheless, somewhat capricious. In 1868 I had some very good examples in vases of very limited size, but they were very small both last year and in some previous seasons, and I can therefore only give them a qualified recommendation. For very small vases, however, they may be tried, and may do well, requiring no attention after planting beyond watering at times, and picking the dead flowers off to prevent the plant exhausting itself with seeding. The extreme brightness of the colours of the flowers cannot well be matched in anything else, and when at their best the *Portulacæ* are everyone's favourites.

MESEMBRYANTHEMUMS.—A small-leaved species named, I believe, *insigne*, has often been used here as an edging to plants of more robust growth. It is a compact-growing and elegant plant, with abundance of starry flowers of the richest magenta colour. It is nearly hardy, not unfrequently withstanding the winter even in an exposed vase. Other *Mesembryanthemums* of more robust growth may be tried, but I have not found any equal to *insigne* for general usefulness.

CENTAUREA GYMNOCARPA.—The fine habit and form of this render it suitable for planting as a centre, to be surrounded by some other plant of a darker colour; but it requires somewhat more nourishment than the majority of vase plants. It is superior to *C. candidissima* for general effect, nevertheless I would not recommend it excepting where variety is wanted.

IRESENE HERBSTII is late in coming into fine condition, unless good plants are put in at first, but with liberal treatment and a favourable autumn it is often very effective. It stands the wind better than the *Coleus*, and is a good autumn plant, perhaps the best in its way.

ECHVERIA METALLICA and other species are better fitted for a sheltered corner or small formal bed than for vases, where *E. secunda* is held in great esteem. I have seen a rather good effect produced by planting a number of small or middle-sized plants of *E. metallica* around the edge of a vase, with a large centre plant of another species, I believe an *Aloe*; but I am not an admirer of such plants in general, and hardly think the vase a suitable place for them.

Having now run through most of the subjects usually planted out for summer effect, I come now to hardy plants, which may be used either for winter display, or to occupy a permanent position. For the latter purpose some variegated *Ivies* are useful, and a good-sized vase with a *Fuchsia* in the centre and *Ivies* hanging round the outside is by no means a bad arrangement, for though the *Fuchsia* may die down in winter, the vase will still be furnished, and the *Fuchsia* spring up again in summer. The Japanese *Euonymuses* may also be employed in the same way, and there is certainly less likelihood of their running into the green state when they are so treated. Much has been said of the value of *Vinca elegantissima* for this purpose, but it is not without its drawback, as the shoots, by dying off in winter, necessitate a new growth, which, by first rising upwards, does not acquire a pendent character until the summer is far advanced, especially if the plants are cramped for room, and, perhaps, imperfectly supplied with water; nevertheless, I think the variegated *Vinca* will have to rank high as a winter

or continuous vase plant, as its graceful habit, when the plant is really good, cannot well be improved upon.

Of plants which may be temporarily placed in such a position for the winter, the most effective we have is *Helleborus foetidus*, a Palm-like plant with dark green foliage. It flowers in midwinter or very early in spring, and has well-shaped pale green blooms, the contrast of the two hues being very effective. The plant is easy of transplantation, its numerous fibrous roots allowing of its removal almost without injury, and it is amongst the hardiest of the hardy. Some of the *Sempervivums* are also suitable for outer edgings, but I have only used *S. californicum* and *S. globiferum*, these and *Sedum glaucum* being sufficient, in general, as dwarf plants, for it is not unusual to plant bulbs and early spring-flowering plants in such places. Among the latter the whole family of *Primula* affords great diversity, as well as the variegated and plain-leaved *Arabis alba*; in fact, this class of plants may be extended to any length, for in a large vase or basket evergreen shrubs of more kinds than one may be so employed, as well as the hardy early-flowering plants.

I now come to plants not fitted for vase work in summer, and as the negative here is as important as the affirmative, I believe the following may be considered as unobtainable, although they rank amongst the greatest ornaments of the garden at the time they are in bloom. *Calceolarias*, *Verbenas*, and *Ageratums* all require more support than they can obtain in a vase, and the same may be said of *Lobelias*, *Salvias*, *Nierembergias*, and some other plants of strong growth, as *Pentstemon*, most of the *Fuchsias*, and *Petunias*, excepting where they have plenty of room. Few annuals do well, excepting dwarf French *Marigolds*, but I have sometimes been successful with several of the summer annual creepers, as *Lophospermum*, *Manrandya*, and the *Canary plant*; but generally they present an immense hump just over the collar of the plant, and the shoots seem rather inclined to plait themselves into a sort of thong rather than to spread out in a graceful manner, like the Ivy-leaved *Geranium*; consequently I now rarely use them, but it is possible some of the newer annuals may be better adapted for the purpose. Only such, however, as are capable of thriving on a limited supply of food are admissible.

The list of vase and basket plants which I have given is far from complete, and I shall be glad if others will supplement it with the names of plants which they have found suitable.—*J. ROBSON.*

P.S.—In page 197, second column, ninth line, for "lawn drain" read "sewer drain."—*J. R.*

THE NEW GRAPES.

SOME time ago a correspondent of "our Journal" complained of his being unsuccessful in making plants from eyes of the *White Lady Down's Grape*. I wrote to Mr. Methven, who kindly supplied me with some eyes, and every eye became a plant. This variety is late in starting, as stated by Mr. Thomson and Mr. Methven, but good in constitution, and in all respects equal to that good Vine, the *Black Lady Down's*. I recommend all to try it. No bottom heat was used, I never do employ it, as more fruitful hardy plants are obtained without it.

Madresfield Court is excellent in constitution, as free as *Frankenthal*—in my estimation the best of all the *Hamburgs*. This is growing strongly and well out of doors against a wooden fence with a south aspect, and on this stock I graft my *Vinea* grown under glass. I offer Mr. Cox, the raiser, my thanks. I think very highly of this *Grape*.

Golden Champion is equally satisfactory, and succeeds perfectly in a house without fire heat. Of my grafted *Vinea* fruiting I cannot yet speak. This has been stated to be the largest *White Grape*; it is a noble fruit, but not so large as *Canon Hall Muscat*.

Of Mrs. Pince, the grafted plants still maintain the first place; this I recommend.

Royal Black, Perpetual Grape, or *Royal Ascot* is very free; the smallest eyes soon make good plants suitable for pot *Vinea*. I have large plants variously grafted; of them anon. In January last a brother amateur sent me some good eyes. I was very successful in rooting them, growing them on in the same way as softwooded plants for flowering, and stopping them. Although this seemed a "very fast" proceeding, I also read in a catalogue now before me that "on the 28th of May, 1868, a house was planted with small canes raised from eyes since the February of the same year (*i.e.*, 1868), which in the October

following had an abundant crop about the size of marbles to ripen during the winter months." I have many plants of this *Vine*, and if it be possible for it to perform in such a manner, it will be the best of all *Vinea* for thousands of small *Grape-growers*, and the raiser deserves public thanks. With me the laterals have not given any fruit, and the plants seem likely only to break at the upper three or four buds of the rods. I send some leaves and three of the laterals for the inspection of the Editors, to show the health and vigour of the *Vinea*, and I shall be glad of information as to growing the *Royal Ascot* in this manner, as so far, with me at least, it is a failure. I shall, however, try again and again if any hopes of success appear, and report progress.—*R. M. W., Fir View, near Sheffield.*

BEDDING GERANIUMS.

As mentioned recently in your columns, this has been an exceptional season for bedding plants, but I send a few notes which may be of interest to some of your readers, having seen all the best new and old varieties of *Geraniums* bedded out and grown as pot plants. I would certainly advise your correspondent Mr. Peach to give them a trial.

First I will notice the scarlet zonal *Jean Sisley*, which will surely become the favourite. It stands the weather better than *Vesuvius*, has a finer-shaped flower with a large, conspicuous white eye, and in brilliancy of colour excels all other *Geraniums* that I have seen either as a bedding or a pot plant.

Next I will speak of the *Stella* class. *Giant des Batailles* is the most abundant bloomer I ever saw, being a great improvement on *Vesta*, *Bayard*, *Waltham Seedling*, and many others of this class. The colour is more intense, and the plant never exceeds about 8 inches in height. *Charlie Casbon* is an improvement on *Lady Constance Grosvenor*, *Cytister*, and many others; it is a most profuse bloomer, produces fine trusses, is very dwarf, and must take the place of the above.

Of semi or Hybrid *Nosegays* *Claude Lorraine* is an improvement on *Dr. Hogg*, for its colour is splendid; the plant is of a fine habit of growth, and the flower of a nice shape; it is the first nearly purple *Geranium* sent out. *Docteur Muret* has orange-scarlet blooms of immense size, and is a very fine grower. Everyone ought to grow it as a bedding or a pot plant on account of the large size of its blooms.

There has been of late a great stride in the *Christine* class, *Beauty of Lee* being a first-rate badder, also a good pot plant; it is of the most intense bright scarlet pink, a good grower, and the best for large beds. Having seen *Magenta Christine*, *Advancer*, *Mrs. C. Cletons*, and *Beauté de Suresnes* growing side by side, I find *Magenta Christine* is the best bloomer; the trusses are smaller, but very abundantly produced. For small beds this is a gem. *Advancer* stands next; it is a self-coloured flower, and good for general bedding purposes. There is a variety not yet sent out called *Master Christine*, which will no doubt eclipse all in this section, and will therefore take their place, being the most abundant bloomer and the richest in colour of any. I have seen this in all stages of growth, likewise at the *South Kensington Exhibition*, where it was awarded a first-class certificate, and was admired by everyone who saw it.

I will now notice the white section. Having seen *Purity*, *White Perfection*, *Madame Martha Vincent*, *White Wonder*, and *Turner's Bride*, I find the last the best, it being a fair bedder and a good pot plant. The flowers are large and circular, with broad overlapping petals, and far superior to any of the *Madame Vaucher* class.

Before closing these few notes I will refer to bedding *Tricolors*. It has been a most trying season for this class, a great many losing their colour and foliage. *Lady Cullum* and *Florence* certainly retain their colour the best; the latter is the better of the two.

Of the *Golden Bronze* bedding varieties which are now acquiring a fine colour I may mention *Plutus*, *Sybil*, *Rev. Mr. Radcliffe*, *Kentish Hero*, and *Crown Prince*. The last-named takes the lead for every purpose, its colour being amongst the most intense; yet it stands the sun admirably, always retaining its splendid zone, and is in every way distinct from the older varieties.

Of the plain yellow-leaved section I have taken much notice of *Creed's Seedling*, which is a most profuse bloomer, producing a number of scarlet blooms long and continuously, and the plant rarely exceeds about 8 inches in height. It makes a splendid bed. Of *Yellow Boy*, *Golden Beauty*, *Star of Gold*, *Golden Emperor*, *Golden Queen*, *Yellow Sovereign*, *Little Golden*

Christine, and Yellow Christine, the first three are decidedly the best, retaining their colour better than any of the others this hot season. I feel fully convinced, had all your Geranium correspondents had the opportunity of seeing the best varieties side by side, that they would have endorsed my opinion.—J. F.

POTATO CULTURE—ALPINE STRAWBERRIES.

I HAVE this season tried allowing only one shoot on each seed Potato to grow, and as you solicit your readers to give the results of their experiments the following is at your service.

I planted a small piece of ground with Rivers's Ash-leaved Kidney. Each row consisted of an equal number of sets 9 inches apart. One row I took under my own especial care, the remainder were planted by my gardener. My sets were planted in a box of pure leaf mould and placed in the greenhouse; as soon as they broke through the surface they were planted carefully in the ridge allotted to them.

The whole were planted in ridges, and each set was put in 9 inches deep; in the hollows were subsequently planted rows of Brussels Sprouts.

The haulm of the general crop died down a full fortnight before my single row showed any symptom of decay, so that the latter commenced growth earlier and continued it longer than those treated in the ordinary way. The result was that a selected row of the latter yielded 7½ lbs. of Potatoes, whereas my row, taken up three weeks afterwards, produced 12 lbs. of very much finer tubers. It was a fair trial in every respect.

Many of your correspondents have been lately writing upon Strawberries, and at page 180 Mr. W. Hindson, of Chase Cliffe, gave his useful experiences on the best sorts to grow on light soils, but neither he nor any of your correspondents ever mention the Alpine Strawberry. What can be the reason of this? It appears to me that it ought to be in every garden. Two years ago I had a packet of seed in one of the collections sent out by the Royal Horticultural Society. Plants came up by hundreds, and were planted out 6 inches apart. They yielded fruit in six months—say seven, I forget to a day. I had some very good dishes in the spring, two months before the general fruit came in. During the heat of summer the yield was scarcely worth collecting, but on the 10th of this month a large dish was picked, and they will go on until the end of October. They are a small fruit, it is true, and they have not the flavour of a British Queen, but broken up with sugar and a dash of claret they are delicious, and then Strawberries in September and October are not to be sneezed at. Again I ask why they are not more cultivated. They will grow almost anywhere—under hedges, under Gooseberry bushes, and our neighbours the French scarcely have anything else—in fact, until the last few weeks positively nothing else; at least, if I am right in believing them to be the same as they call "Tous les Mois." I can detect no difference. They have a drawback—everything has—they throw out an infinity of runners, which take root easily, and without attention become matted together. Will any of your clever and able growers explain why this class of Strawberry is never spoken of or recommended?—H. WATSON, *Old Charlton, Kent.*

DYMOND PEACH.

THE history of this Peach is soon told. The late Mr. Veitch, of the Mount Radford Nurseries, Exeter (grandfather to the present Messrs. Veitch, of the Royal Exotic Nursery, Chelsea), met with it in the garden of a gentleman named Dymond. Mr. Veitch saw the good qualities which it possessed, propagated it extensively, and called it the Dymond, and it is now widely distributed over the western counties under that name. I never heard Mr. Veitch mention it as a new variety; but if it was not new it was a sort he did not know, and from the many good qualities it possessed he strongly recommended it to all fruit-growers. It is very hardy, a great bearer, later than the Royal George, and differs from all that section in having large flowers. It resembles the Hemskerk by the very small, round, and smooth stone. It usually ripens in Devon from the middle to the end of September, but in late seasons will last into October. The leaves are deeply and doubly serrated.—A. McKELVIE, *Torrington.*

[Thanks for the buds.—Eds.]

DAMSONS.—When Mr. Crittenden's crop of the present season is all gathered I shall have something further to say on

this fruit, and especially on the variety that bears his name.—J. ROBSON.

NOTES ON ROSES AND ROSE STOCKS.

THE Rose is my favourite, and I love her "oh, how well!" I have now exactly four hundred plants, of which three hundred are Perpetuals, and I have had the greatest of pleasure from them this year. My soil is perfection for Roses—a good rich stiff loam. The hedges bristle with the Dog Rose, but yet, in spite of the Rev. S. Keynolds Hole, give me the Manetti. I have many plants of the same varieties on both stocks; during the last two summers the result has been a long way in favour of the Manetti. Both for size, colour, and health there has been no comparison; even Manettis planted last autumn have beaten long-established Briars, especially Alfred Colomb, Charles Lefebvre, Fisher Holmes, Victor Verdier, and Dr. Jamin. They were failures on the Briars. Mildew set in very early, but I soon subdued it on the Manetti; I was powerless on the Briar. May this not be one great cause—the long stem of the Briar is so acted upon by the sun that the nourishment cannot make its way to the head before it is dried up by the sun? In future I shall have nothing on the Briar but strong-growing Tea Roses.

I have a plant of Unique planted out last May; it has now made a grand plant, and is flowering most abundantly. Marie Sisley refuses to open out of doors, but has done well in a pot in the conservatory. I let me recommend my brother amateurs if they want always to have a Rose in their garden from which to cut a lovely bloom, to invest in two or three plants of Archimède; with me it is beautiful. I see but little mention of Charles Margottin in the various letters on Roses; with me (in Somerset) it is grand.—STIFF SOIL.

NOTES FROM BELFAST.

IN the well-known and excellent Botanic Gardens at Belfast on the 8th and 9th inst., was held the first, we believe, of a series of great horticultural exhibitions after the style of the Regent's Park and Manchester Shows, which have never failed to please. Horticultural exhibitions in Belfast are not new things; they have, however, never been particularly successful; the late Show was, therefore, a bold attempt on the part of the Directors of the Botanic Gardens to resuscitate them, and to introduce the Belfast people to new pleasures by adopting a new style of arrangement in their exhibitions. The attempt, we are happy to state, was so far successful, reflecting considerable credit on the very energetic Curator, Mr. J. F. Johnston, under whose management the whole was carried out.

The grounds where the Show was held were exceedingly well laid out for the purpose, about 80 yards in length and 30 yards in breadth, the centre being somewhat hollowed and cut up into irregularly-shaped beds and mounds of grass, on which the plants were placed. This piece of ground had been previously prepared, and was in good condition, greatly marred, however, by the use for the walks of ugly coal ashes, which contrasted badly with beautiful flowers. A huge canvas tent was erected, supported by a great wooden framework and four lines of exceedingly ugly rough Larch trees, which proved a great eyesore. The arrangement of the Show itself was in some respects faulty; the centre, which ought to have been the chief point, being particularly bare and destitute.

Prizes to the amount of £200 were offered for competition, and very spirited in some cases was the contest. The display of Fuchsias was remarkably fine, far surpassing anything of the kind seen about London for years, those from Professor Yonghe and Mr. Hawkins being particularly fine. Zonal Pelargoniums were likewise well displayed, also exotic Ferns, for which the Belfast people seem to have a particular regard. Hardy Ferns were likewise shown in great numbers, and among them were many remarkably fine varieties. The Dahlias from Messrs. Dickson, of Newtownards, were about the largest and best finished flowers we have ever seen. Roses, for the season, were also well shown. There were, besides, some very good examples of stove plants, *Ixoras*, *Bambusa Fortunei*, *Yucca variegata*, *Sanchezia nobilis variegata*, *Cyanophyllum magnificum* and *Bowmanii*, a very fine *Croton variegatum*, and *Anthurium magnificum*. *Vallota purpurea* was particularly well shown. We only observed one "wee" solitary Orchid, which even Mr. Anderson almost overlooked. Bouquets were well represented, showing better taste than is to be found in many places.

Fruit was pretty well shown, the competition for the collection between Mr. McLacklan and Mr. Mason being very close. Black Grapes were in pretty good order, and there were some good Muscats. There appeared here with the exhibitors a slight inclination to prefer the big coarse Trebbiano to the smaller sorts. Peaches and Nectarines were wonderfully good. There were also some good Figs and Plums—Jefferson, Reine Claude de Navay, Victoria, &c., being the principal sorts of the latter. Pine Apples were at a minimum, there being only one "one-pounder." Several good dishes of Pears were shown, including fine examples of Jargonelle, the best of all summer Pears for the north. Apples were also well shown, a collection of about forty sorts coming from the gardens of Colonel Leslie, Glasslough. The Kerry Pippins in several instances were particularly fine, and this is a truly Irish Apple.

Vegetables were also well displayed. Parsnips were particularly fine, yellow Turnips and Celery very excellent, and there was a fine lot of Potatoes, consisting of Berkshire Kidney, Paterson's Victoria, Paterson's Blue, Fortyfold, and a good-looking sort called Crofill's. Mr. Meredith, of Garston, exhibited a small box of very fine black Grapes. These were exceedingly meritorious, but very badly shown. Mr. Fowler, of Castle Kennedy, had a very large bunch of Syrian Grapes, weighing over 15 lbs. This, although large, was in no respect captivating.

The Judges on this occasion were all men of sterling ability—for the plants, Dr. Moore, Glasnevin; Mr. P. Robertson, Edinburgh; and Mr. Anderson, Meadow Bank; for fruit, &c., Mr. Stevens, Trentham; Mr. Meredith, Garston; and Mr. Fowler, Castle Kennedy. It showed a praiseworthy desire on the part of the Directors to secure such high talent, and so far so good; but why should they have exerted themselves so little afterwards, the whole burden of the duties appearing to be shelved on the Curator, Mr. Johnston, who acted as Assistant Secretary?

We are pleased to state that financially the Exhibition has proved successful, being visited on the first day by all the *élite* of the wealthy and thriving city of Belfast.

THE CHILWELL NURSERIES.

THE extensive nurseries of Mr. J. R. Pearson, of Chilwell, near Nottingham, from the variety of interesting objects which they contain, possess many attractions both for the florist and pomologist; for there the culture and preparation for sale of the most useful varieties of fruits and flowers, as well as a host of other things, are carried on with such energy and skill, and such painstaking attention to minor details, as are not only most praiseworthy of themselves but highly advantageous to the purchaser.

One of the most attractive features of Chilwell this autumn is the bedding Pelargoniums, or Geraniums as they are commonly called, and to these, therefore, I purpose first of all to draw the attention of your readers. For some years past Mr. Pearson has devoted much time and money on the work of raising seedling Pelargoniums, impregnating most of the flowers with his own hands, and flowering about five thousand seedlings every year in his trial grounds. From this large number he has selected those which have appeared sufficiently meritorious to be subjected in following seasons to the severe test of a comparison with the best varieties in cultivation, with which they are planted side by side: and so he has gone on selecting and discarding with a keen eye to the development of all the most important points of excellence in this class of plants, till at length a collection has been formed of proved kinds of such sterling merit, and which are so decidedly superior to almost all the best established sorts, that I am confident they must command universal acceptance at the hands of true lovers of the flower garden. Nor does it appear that Mr. Pearson intends to rest content even with his present splendid success, for a view of his trial garden this autumn fairly bewilders one, and it was not till I saw in full bloom the thousands of magnificent seedlings which are there that I could realise the immense amount of labour which selection implies.

That Mr. Pearson sets his standard of excellence very high may be easily inferred from the fact that out of all the hosts of seedlings which have passed under his critical eye the collection of named varieties offered to the public does not much exceed two dozen in all. Of these I may select Bayard as one of which something is already known; this is a sterling variety in every respect, with an abundance of large trusses of rich crimson

flowers, and with a free yet compact habit of growth. Brighter in colour than Bayard, and with a profusion of magnificent flower trusses, is Douglas Pearson; in its habit of growth it is everything that one could wish, and I have no hesitation in naming it as the most magnificent bedding Pelargonium I have ever seen. Arthur Pearson is another useful introduction in the way of Amy Hogg, but surpassing it in every respect, especially in its brighter colour and larger petals. Then comes Othello, of a deep rich crimson, equally fine in growth and flower; this will, I think, prove a splendid variety for massing, its dark complexion being far more likely to be admired by the ladies than was that of Shakspeare's hero. William Thomson, of a deep shade of scarlet, is also a kind that will be highly valued; it forms a close compact mass, and is peculiar from its very neat and erect habit of growth. Milton, too, is another fine variety, excellent in every respect, and of a peculiar and distinct shade of colour, which may be described as a cherry red. Another, named Duke of Devonshire, with rosy red flowers, is a splendid variety, with a profusion of such huge trusses that I was tempted to measure one, which proved to be fully 5 inches in diameter; it has a compact and erect habit of growth. Mrs. Mellows has very dark rich crimson flowers, and the trusses are very large and well-shaped. An important peculiarity of the Chilwell seedlings is the duration of the flowers, for I noticed that in almost all the fully expanded trusses the flowers which opened first still remained intact.

Of other varieties of the No-egy tribe Alfred Pearson deserves mention, its stout-petaled flowers of fine form and of an attractive shade of rose are freely produced in fine compact trusses. Lawrence Heywood is also a promising kind, having a fine spreading habit, with its flowers of a deep shade of cherry with a dash of magenta. Thomas Speed another of this shade of colour, but quite distinct, has very large flowers, but it appeared to be hardly compact enough in the truss; yet its free growth, and the bold and striking appearance which a mass of it produces, are qualities very much in its favour. Nor must I omit to mention another, named Mrs. Henderson, of a peculiar shade of colour, which may be called violet crimson; it has flowers of fine form, and is a promising variety. All the foregoing kinds belong to the Nosegay section. Three other varieties of broad-petaled scarlets were very fine; these were E. J. Lowe, a splendid sort, having very large flowers of fine form, William Hill, and Rev. John Woolley.

Among the Golden Tricolors Edith Pearson, from its dense, compact habit of growth, and the brilliant markings of its very flat circular foliage, will prove a useful introduction both for pot culture and beds. Another of this section, named William Sandys, is the most vigorous Golden Tricolor I have met with; many of its young shoots were 9 inches long. It is also peculiar from the very deep green centre of its foliage, in which the yellow and crimson colours are well developed. So striking was its effect, that a mass of Sophia Damaresque growing near it made a very poor display. Mrs. Edge is also a pleasing variety, from its pretty compact growth and well-formed foliage. My last selection from this group is Monsieur Durand, and a very handsome dashing fellow he is too, decked out after the latest fashion in the brightest possible crimson, yellow, and green, and with a freshness of appearance that at once attracts one.

I come now to another distinct variety, named Pearl, a white variegated sort, having a dark zone on its foliage, but with a very broad pure white leaf-margin, having flowers of a pleasing shade of pink; it is just one of those rare gems among variegated plants in which the colours of foliage and blossom contribute to each other's beauty, in this instance producing such a chaste effect that it must become a general favourite; and I was not surprised to hear Mr. Pearson say that he was afraid he should be unable to propagate a sufficient stock of it to supply the requirements of his customers. Another silver-variegated kind with which I was much pleased, but which was not raised by Mr. Pearson, was Miss Kingsbury. Its flowers are of such a soft shade of rosy scarlet, that in certain positions they might be retained with advantage; out this kind, from its dense growth and fine broad silver leaf-margin, is peculiarly adapted for producing a fine effect by the beauty of its foliage alone.

The select Pelargoniums which I have thus described are all varieties of sterling merit, and they are certainly a great advance upon most of our best-known and most popular bedders. To prove the merits of his own kinds thoroughly, Mr. Pearson has introduced beds of such well-known kinds as Stella, Lady Constance Grosvenor, Blue Bell, and others, and I was amused

to see the poor appearance which even Stella presented alongside the Chilwell varieties. I do not doubt if Mr. Beaton had lived to see varieties so greatly surpassing his own pet sort, he would have been among the first to accord them his hearty admiration. Although planted near the best kinds which I have named, yet a bed of Violet Hill was as effective here as elsewhere, and this, to my mind, tends more than anything else that has been said in its favour to stamp it as a first-class bedder.

All these Pelargoniums were planted on the lawn near Mr. Pearson's residence, each kind filling a circular bed of sufficient size to give a good mass of colour, so that one was able to judge very fairly of their merits and fitness for the flower garden. These beds were not all together, but were dispersed among the fine masses of Rhododendrons and beautiful specimen Conifers which are the permanent occupants of this pleasant lawn, and they have grown into beauty under the hands of the present owner during the past twenty years. A fine Wellingtonia is about 30 feet high, and in perfect health and vigour. Mr. Pearson attributes this principally to the bed of very deep rich soil in which it is planted, and it is his opinion that the chief cause of decay in so many fine young Wellingtonias is because a suitable provision is not first of all made for the perpendicular or tap roots which force their way so deeply into the soil, and as this tree depends very much upon such roots for its sustenance, it is but reasonable to suppose that a shallow soil would quickly become exhausted. This is worthy of attention, for it would be a fallacy to suppose that those huge trees still flourishing in the primeval forests of America ever attained their gigantic proportions by the aid of mere surface roots; and, therefore, if succeeding generations in our own land are to see our native timber trees dwarfed by mighty Wellingtonias, too much attention cannot be given to the selection of the best situation and careful preparation of the soil. The plant to which I allude above was, when planted in its present position in 1860, only 1 foot high.

Another point in the culture of Conifers on which Mr. Pearson lays great stress, is the planting of the trees in their permanent stations when quite young, as he is able to demonstrate that small healthy young trees not only acquire the handsomest proportions, but by their more vigorous growth they soon beat those large specimens which have been transplanted so often before occupying their permanent quarters. Among the many fine examples growing on the lawn here, there are very fine specimens of *Cupressus macrocarpa*, the branches of one having a spread of 18 feet in diameter at the base, while the plant cannot be more than 14 or 15 feet high. *Cupressus Lawsoniana* was also fine, its pendulous shoots giving it a very graceful appearance. This and numerous other species were all well furnished with branches downwards to the turf, and as good lower branches are among the principal attractions in this class of trees, the mode of culture followed here appears to be the right one. In some instances where the young trees did not produce lower branches in sufficient quantity, cutting off the leading shoots has proved an effectual remedy. By this somewhat startling operation the vigour of the tree is almost entirely thrown into the side branches for a year or two, and in time a sturdy leader is again formed, growing so erect as to render it a difficult matter in a few years to discover its starting point. A beautiful specimen of *Picea Nordmanniana* was pointed out to me, the leader of which was accidentally cut off some years ago, and it is now as handsome a specimen as any on the lawn, with a particularly dense mass of lower branches resting on the turf, from whence it tapers upwards in most elegant proportions.

A few good beds of Cannas near the margin of the lawn were noteworthy from the agreeable effect which their foliage had when thus contrasted with that of the Pinuses.

Passing from the lawn we at once come to the glass houses, twenty-one in number, nearly the whole of them being of the span-roof form, and many of them being really magnificent structures of noble proportions, of great strength, and yet, from the judicious use of iron pillars and ties, they have a light and elegant appearance. They were built by Mr. Foster, of Beeston, but the elaborate details are, I believe, the joint conception of Mr. Pearson and Mr. Foster. Nothing appears to have been overlooked in the building of these houses; the ventilating apparatus is as simple as it is effective, and I saw many ingenious appliances, the usefulness of which I could not but admire. One novel feature was that of the form of the glass; the ends of the panes, which lap over each other, instead of being cut straight or at right angles with the sides, had a

semicircular outline, and thus the moisture from evaporation inside the house, instead of gathering along the edges of the glass and dripping on the plants beneath, runs down the centre of the panes in a single stream. Another plan for the avoidance of drip was that of a broad groove along each side of the roof bars holding the glass, which thus had concave sides instead of the usual flat surface, by which means any accumulation of moisture on the woodwork runs downwards to the front or sides of the house.

The houses and their contents were alike interesting; one, an orchard house 90 feet long by 30 wide, contained a remarkably fine healthy stock of Peaches and Nectarines in pots of all sizes and heights; a number of very large standard Peach trees planted in one of the borders had been cropping heavily, and there was still enough fine fruit remaining to convince one of the excellence of the entire crop. A few Vines, trained at intervals along the iron rods used to strengthen the roof, had an agreeable effect. Another orchard house contained an equally fine batch of pot trees all in a flourishing condition; here, too, were a number of standard trees bearing fine crops. The sight of the trees leads to the conviction that where the houses are lofty enough, Peaches may be grown so with much less care, and with results quite equal to that of any other more laborious method.

The pot Vines at Chilwell are a grand sight. They are grown principally in two span-roofed houses, one 60 feet by 20, and the other 100 feet by 24. They were all in splendid condition, forming such a collection of noble, well-ripened canes as is very rarely to be met with. The collection of sorts is good, comprising all the leading varieties. Another of these fine houses, intended eventually for a Fig house, was filled principally with Figs and a variety of standard fruit trees in pots.

The grand viney, of which a section is figured in Mr. Pearson's book on Vine culture, is 100 feet long by 24 wide. The entire length of one side is taken up by seedling Vines, which form a most interesting sight from the varied appearance of the foliage, a sure sign, in Mr. Pearson's opinion, of success in the operation of impregnation, which is well known to be a work of great difficulty, requiring much skill and watchfulness on the part of the operator, owing to the peculiar structure of the flowers of the Grape Vine. Among these seedling Vines was a plant of *Ferdinand de Lesseps*, raised by Mr. Pearson, and awarded a first-class certificate by the Fruit Committee at South Kensington. This is the most distinct and remarkable Grape of modern introduction. The berries are of a fine golden amber, but it is the full rich Strawberry flavour that renders this variety so remarkable, and I am confident that there is no one caring for Grapes at all but who, after tasting this delicious sort, would wish to grow it. From what Mr. Pearson told me of its hardiness and vigour, it is likely to thrive in a cool viney equally with the Black Hamburgh, and if this prove to be the case it will be an acquisition indeed. On the opposite side of the house were a number of young Vines bearing some magnificent fruit, among which were some grand bunches of Muscat of Alexandria, equally fine in bunch and berry, and thoroughly well finished. Bowood Muscat, Black Hamburgh, and Muscat Hamburgh were also fine; an extraordinary, but by no means handsome, bunch of the latter kind had such wonderful shoulders that I measured it, and it was actually fully 2 feet across. Mrs. Pince, too, was very fine, and Mr. Pearson spoke very highly of it. Frankenthal, or Victoria Hamburgh, was equally good, with berries of a large size.

The conservatory is a fine house, filled principally with a healthy stock of Camellias all growing in a pure turf soil. Among the miscellaneous plants, *Pelargonium echinatum* with its clusters of pretty white flowers, having a crimson blotch on the upper petals, was an attractive object; this fine old species is most useful to cut from; its sprightly flowers would have a charming effect in a bridal bouquet.

Another long, low, span-roofed house was filled with plants of the famous Long Gun Cucumber, growing on a trellis; they were in pots, which were plunged in cocoa-nut fibre, into which the roots had penetrated on all sides, apparently very much to the benefit of the crop, which was a very fine one.

The two long ranges of span-roofed pits struck me as being the most admirable structures of the kind that I have seen; great utility and simplicity are their leading characteristics. A description of them has already been published in "our Journal" by Mr. Pearson, but as it is probable that their full value is far from being understood, I will give a slight sketch of them. A low 9-inch wall forms the sides and ends; half the width of the

top of this wall is taken up by the plate on which the roof rests, thus leaving space enough inside for the 4-inch pipe which runs along each side. The sashes or lights, which are on hinges, do not meet at the apex of the roof, but a space wide enough for thorough ventilation is left by attaching the sashes on each side to a separate bar or plate. The opening along the top of the roof is covered by a moveable wooden cap, which is raised and lowered throughout its entire length by simply turning a wheel. To say that the lights are hung on hinges is not strictly correct, for there are no hinges at all in the true sense of the word, but two small hooks or angle irons are attached to each light, one on each side at the top, and when the lights are in their proper positions, the hooks fit into grooves or little semicircular pieces of iron which are sunk in the top bar, and so the lights can be raised or lowered with as much facility as if they were hung on real hinges. Moreover, by this simple contrivance each light can be lifted off at pleasure, and all annoyance from stiff or broken hinges is avoided. The body of the pit is filled with cocoa-nut fibre in which the pots are plunged. I need hardly point to the numerous uses to which these capital structures may be applied at all seasons of the year; from their lightness, simplicity, and great practical usefulness, they are certainly very superior to the old style of pit, with its costly high-raised walls and heavy sliding sashes.

The general nursery stock was in a healthy and flourishing condition; it consisted of the usual varieties of Conifers, fruit and forest trees, and shrubs. The soil of the various quarters of the nursery among the young stock is kept free from weeds, by allotting the work to the men at a stated sum per acre, for which the surface has to be kept thoroughly clean and well stirred throughout the growing season. This plan not only acts as an incentive to the labourers to earn all they can, but it also develops their intelligence sufficiently to enable them to see the wisdom of never trampling on a weed after it is hoed-up.

By the kindness of Mr. Pearson I was enabled to see something of the famous Chilwell orchards, of which I believe there are seventy acres; as most of the trees were laden with a heavy crop of fruit, it was an extraordinary and interesting sight. I noticed several handsome trees of the Bess Pool Apple, but the most attractive and showy fruit that I saw was Duchess of Oldenburgh Apple, a very handsome striped kitchen fruit, which, ripening early, most command a much better sale than such pale-skinned kinds as Keswick Codlin and Hawthornden. It is a heavy cropper, and its fruit grows to a large size. A number of dwarf Plum trees had heavy crops of fruit; they consisted principally of those excellent hardy kinds, Denyer's Victoria and Prince Englebert. Large numbers of trees of the Shropshire Dimson had a heavy crop of fruit.

One other notable feature of these orchards is the numerous huge Pear trees bearing a full crop of fine fruit. Most of these trees some years ago had arrived at that tantalising state of barrenness with which all fruit-growers are familiar; but instead of destroying them after the usual fashion, Mr. Pearson had the whole of the branches cut off, not close to the stem, but a long way from it. They were grafted with useful kinds which have flourished so vigorously that without looking closely it is difficult to see the junction of stock and scion, and ever since this operation the branches resulting from the grafts have been most prolific.—EDWARD LUCKHURST.

INQUIRY.

HAVING answered an advertisement which appeared in THE JOURNAL OF HORTICULTURE of July 21st, by Wm. Dillistone, Nurseries, Sible Hedingham, Essex, in which he offered twelve double Pelargoniums for 6s., which sum I sent to the above address in stamps on the 4th of August, I wrote again on the 13th ult., but still no reply. I wrote to the General Post-office, and the reply is that my letters were duly delivered. The Post-office authorities state that Mr. Dillistone left Sible Hedingham on the 17th ult. Can you inform me of his whereabouts?—S. T. FOSTER, 13, Washington Road, Sheffield.

ABUNDANCE OF MUSHROOMS.—Have any of your readers noticed the extraordinary crop of Mushrooms there has been this year? I have never witnessed anything like it; for the last three weeks the fields about here have been covered with them. I gathered this evening six of the largest I have ever seen or heard of; one of them measured 8 inches in diameter;

the stalk was about 7 inches high. Is not this size rather unusual?—AN OLD SUBSCRIBER, Co. Dublin.

[We never saw such abundant natural crops of Mushrooms as we have seen on the pastures this year in Northamptonshire, Sussex, and other counties.—EDS.]

METROPOLITAN FLORAL SOCIETY.

I HAVE to thank "L. W." for his kindly and cheery words, they are, I rejoice to say, but echoes of many others which I am continually receiving; and amidst the difficulties which have attended the starting of a new Society, I have been greatly helped by the words of those whom I have never seen, and who know me only as a scribbler or brother "maniac."

With regard to the future of our Society, we have considered that it would be very unwise to risk everything in holding independent exhibitions, which might prove failures and cripple our exertions; we, therefore, adhering to our original programme, mean with the liberal assistance of the Crystal Palace Company, to hold an annual autumn show there; this will take in three of the flowers named—the Dahlia, Gladiolus, and Hollyhock. We have already made overtures to the Royal Horticultural Society to offer special prizes in April for Auriculas, and in July for Carnations and Picotees, the arrangement of these prizes to be left to us, and to be regulated by the amount of support we shall obtain. We have not yet determined what course we shall adopt with regard to the Pansy, Pink, Ranunculus, and Tulip, but it will probably be to offer prizes for them in the same manner at the Crystal Palace exhibition in May and June. I need not, I hope, say that in all this we shall act entirely independently, and shall endeavour to do our best to advance the interests of our favourites, having, so the Committee has decided, especial reference to amateurs. We are preparing a report of our proceedings, which I shall be happy to forward to "L. W." and any other friends, and I am prepared now to receive the names of anyone who may desire to join us. Our motto must be *Amor omnia vincit*; love of our flowers, and brotherly love to one another.—D., Deal.

THE FLOWER SERMON.

I AM glad to observe that you have extracted, at page 208, a short account of the flower sermon. I beg permission to make a correction in it. The plant found by Mungo Park in Africa was not a blue flower but a Moss, which bears no real flowers. He brought it home with him, and it was ascertained by his brother-in-law, James Dickson, of Covent Garden, the eminent cryptogamist, to be the *Picranum bryoides*. It is abundantly produced in our hedgesides and by sides of newly cut ditches in spring. It is figured in plate xvi. of Hooker and Taylor's "Muscologia Britannica," second edition, London, 1829.

Dr. Whittemore was entirely ignorant of Fairchild's bequest when he commenced his annual flower sermon. Whether such sermons are still delivered in Shoreditch Church I know not. Jones, of Nayland, delivered some of them, and I should be glad to learn if either his or any of the others have been published as some of the Boyle lectures have been. All honour to Dr. Whittemore, who began his interesting discourses *proprio motu*.—A CONSTANT READER.

WATER CRESSES GROWN OUT OF WATER.

I WISH to tell that one of your contemporaries is wrong in saying that Water Cresses not grown in water are not fit to eat. Six-pennyworth of seed having been sown at Stanmore Lodge, Penge, last spring, in a few weeks we had plenty of Cresses, and we have had enough for the family ever since. The value, at the lowest, would be 2s. per week, and this off about 4 square yards of ground. So far from the plants standing in water, they stand about 6 inches above the level of the ground. The Cresses are excellent.—S. HATCHING, Maple Road, Penge.

MISTLETOE ON THE OAK.—The extreme rarity of well-authenticated examples of the parasitism of the Mistletoe on the Oak has induced Dr. Bull, of Hereford, to collect the known instances, which he finds to be eight in number—viz., three in Herefordshire, and one each in Gloucestershire, Monmouthshire, Devonshire, Hants, and Surrey. In the most recently discovered instance, in the Forest of Deerfold in Herefordshire,

the Mistletoe was found on an Oak of the species *sessiliflora*, some fifty or sixty years old; it is a female plant, growing high up on the main stem, and forming a large spreading branch with a diameter of 3½ feet, and springing from the Oak in a single stem nearly 4 inches in circumference. The Mistletoe also grows on a Thorn close by, and has probably sprung from a seed dropped by a bird from above.—(Nature.)

ROYAL HORTICULTURAL SOCIETY.

SEPTEMBER 21ST.

THERE was on this occasion an excellent show of novelties, although the subjects specially invited in the floral department were but poorly represented as regards numbers, and were but fair in quality. On the other hand the Fruit Committee had their hands full. On the whole the meeting sustained the good character of its predecessors, and, though a large attendance could not be expected at this season, there was a fair sprinkling of visitors.

FRUIT COMMITTEE.—G. P. Wilson, Esq., F.R.S., in the chair. Mr. William Paul, The Nurseries, Waltham Cross, sent a number of seedling Grapes; many of them were very excellent, but none sufficiently meritorious to receive any special award. Messrs. Lane & Sons, Great Berkhamstead, sent a magnificent collection of fifteen varieties of Grapes, some of them very large and fine, to which a special certificate was awarded. Mr. Clarke, gardener to J. Brown, Esq., Holmshush, Horslam, sent three fine bunches of Black Alicante Grapes, beautifully coloured but quite acid. Mr. Webb, Calcot, Reading, sent a basket of Black Hamburg Grapes, grown in the open air. Mr. Rochford, market gardener, Page Green, Tottenham, sent a fine example of Charlotte de Rothschild Pine Apple, weighing 9 lbs., but it was scarcely ripe. Mr. Perry, Algar Kirk, Spalding, sent some seedling Grapes which were considered simply Black Hamburgs.

Mr. G. Goldsmith, gardener to G. D. Fryer, Esq., Hollenden Park, Hildenborough, sent a dish of remarkably beautiful Peaches, named Coupe d'Hebe. They somewhat resembled Bellegarde. The variety was not known. Mr. Goldsmith further exhibited a dish of Late Duke Cherries. Mr. Smith, gardener to the Earl of Gainsborough, Exton Park, Oakham, sent some examples of Prince of Wales Nectarine, a fine late variety.

Messrs. Wheeler & Son, nurserymen, Gloucester, sent examples of a seedling Pear, named Brockworth Park, which greatly resembled Louise Bonne of Jersey, but it was much larger and finer. It was awarded a first-class certificate. Mr. Tillery, of Welbeck, sent some examples of Williams's Bon Christian Pears, also examples of a fine large seedling Apple. Mr. Hurdley, gardener to E. J. Weld, Esq., Lutworth Castle, Dorset, sent examples of a large green kitchen Apple. Mr. W. Reid, Sydenham Hill, Kent, had examples of a small flat Russet dessert Apple.

Mr. Gilbert, gardener to the Marquis of Exeter, Burghley, Stamford, exhibited examples of two enormous hybrid Melons. One named General Molke weighed 9 lbs.; the other, Princess Louise, weighed 15½ lbs.; excepting for great size, which is not required, these were in no way remarkable. Mr. W. Paul sent a box containing about thirty varieties of Apples, to which a special certificate was awarded. Mr. Gilbert exhibited good examples of Cox's Golden Drop and Reine Claude de Ravay Plums. Mr. Eckford, Coleshill, again submitted his seedling Nectarine. Mr. Penn, Woodstock, exhibited some interesting examples of Apples, showing the effect the stock has upon the scion. Ribston Pippin grafted on the Blenheim Pippin had quite lost its character, being so different both in appearance and flavour that no one could have recognised it. Mr. Penn also submitted a pie made from the fruit, but it was too much sweetened.

Mr. Penn exhibited a very large and interesting collection of Potatoes, showing the results produced by grafting to be in every instance to deteriorate instead of to improve. The true Milky White was exhibited cooked, also the same sort grafted on the Fluke. The latter was inferior to the former. A special certificate was awarded to Mr. Penn for his excellent and interesting collection. Messrs. J. C. Wheeler & Son sent some very fine examples of a green Cos Lettuce, named Highnam Court. Messrs. Carter & Co. contributed some good examples of Giant Rocca Onion. Messrs. Veitch & Sons, Royal Exotic Nurseries, Chelsea, had a large and fine collection of Beetroot, examples of which were cooked for the Committee. A special certificate was awarded.

M. Verhulpen, of Brussels, exhibited Bonckart's Patent Fruit-gatherer, a very ingenious instrument for gathering Pears and Apples on high trees without the necessity of ladders to get at them. This, which we shall notice more fully afterwards, was greatly approved by the Committee, and was awarded a first-class certificate.

Prizes were offered by H. Bohn, Esq., for Peaches grown on standards in the open air, for which there was one exhibition. The Committee, however, believed the fruit had been grown on walls, and consequently withheld the prize. A prize was also offered for a collection of Tomatoes, for which Messrs. Carter & Co. exhibited a very extensive collection of varieties both in pots and as cut fruit; to these the first prize was awarded. For the best dish of dessert Pears the first prize was awarded to Mr. Douglas, Loxford Hall, for Cox's Orange Pippin; the second was awarded to Mr. Craddock, Compton Verney, Warwick, for the same. For the best dish of Pears the first prize was

awarded to Mr. Smith, gardener, Exton Park, for Benrre d'Amanlis; the second prize to Mr. Craddock, Compton Verney, for Louise Bonne of Jersey.

FLORAL COMMITTEE.—Mr. J. Fraser in the chair. From Messrs. J. Brooke & Co., Fairfield Nursery, Manchester, came a magnificent new Dendrobium, named *D. chrysois* by Professor Reichenbach. The flowers of this were about 3 inches in diameter, and of a rich yellow, the lip beautifully fringed, and of the same colour, but with two dark purple blotches at the base. To this a first-class certificate was awarded.

Messrs. Veitch, of the Royal Exotic Nursery, Chelsea, sent a numerous and very fine collection of Orchids and Pitcher Plants. Among the former were splendid examples of *Odontoglossum grande*, the brilliant *Masdevallia Veitchii*, *Vanda Bensonii*, *Pescatorea cerina*, *Cypripedium Harrisianum*, *C. concolor*, several fine varieties of *Cattleyas*, *Lalia elegans*, and *Sobralia macrantha* in beautiful condition. The *Nepenthes*, or Pitcher Plants, were magnificent specimens, some of them with upwards of two dozen pitchers. They consisted of *Nepenthes Domitiana*, *Rafflesiana*, and *Hookeri*, each with large and finely-marked pitchers, *N. hybrida*, and *N. hybrida maculata* with a multitude of pitchers, blotched with dark red. A special certificate was awarded the collection. Messrs. Veitch also exhibited Brazilian or Chilian Beet, with most brilliant-coloured leafstalks, and Dell's Crimson, well known by its compact, finely-coloured tops, whilst the root is excellent for culinary purposes.

Mr. B. S. Williams, of Holloway, also sent a fine collection of *Odontoglossum grande*, together with *Cypripedium Stonei*, *Phalænopsis amabilis*, and the pretty pink and white *Oncidium ipcurvum*. A special certificate was given for the collection.

From Messrs. J. & C. Lee came a collection of Orchids and fine-foliaged plants. Among the Orchids was *Dendrobium catheolae*, with a profusion of orange yellow flowers; and among the fine-foliaged plants were several very handsome Palms, such as *Livistonia rotundifolia*, *Cocos Weddelliana*, *Geonoma Verschaffeltii*, *Areca Verschaffeltii*, and *Chamadorea graminifolia*. The last is an elegant Palm for a basket, in which way it was exhibited. A special certificate was awarded. From the same firm came Mrs. John Lee, a most beautiful Gold and Bronze Pelargonium, with a deep rich-coloured zone. This had been grown in the open ground, and well deserved the first-class certificate awarded it. Along with this was Edward Milner, a Golden Tricolor, likewise lifted from the open ground. *Livistonia altissima*, forming part of the collection of Palms, received a first-class certificate.

Messrs. E. G. Henderson, St. John's Wood, contributed a collection of tree Carnations; dwarf Asters; Golden and Silver Tricolor Pelargoniums, very fine; *Hydrangea japonica speciosa*, a handsome white variegated sort, which had before received a certificate; *Thymus citriodorus aureus*, a pretty dwarf golden-leaved variety; and *Alternanthera magnifica*, a finely-coloured bronze and rose variety. To each of the two last-named a first-class certificate was given, and special certificates were awarded to the collections of tree Carnations and Tricolor Pelargoniums. *Cineraria splendens*, with very ornamental silvery foliage, also received a first-class certificate.

Messrs. Ivery & Son, Dorking, exhibited a numerous collection of early British Ferns, and likewise a number of new varieties, of which *Scolopendrum vulgare Iveryanum*, *S. vulgare lacerato-cristatum*, and *Polystichum angulata congestum*, were awarded first-class certificates.

Mr. W. Paul received a special certificate for four boxes of cut Roses, very fine for this time of year, and accompanying these were fine Asters and cut blooms of Zonal Pelargoniums. Mr. W. Paul likewise exhibited Silver Tricolor Marchioness, with a broad white edge, a very promising variety, which requires, however, to be seen in better condition.

Mr. Thomas Hobbs, Lower Easton, Bristol, had a first-class certificate for self Dahlia Annie Hobbs, white, and a second-class certificate for Robert Lambert, dark maroon. Mr. Rawlings, Romford, had a like award for George Peabody, a well-formed maroon flower. Rev. C. Roe, Welnetham Rectory, Eury St. Edmunds, exhibited Suffolk Gem Dahlia, in the way of Stafford's Gem. Gem of the Grove, a beautiful flower of the same character, but finer, had a first-class certificate; this came from Mr. Harris, Orpington. Second-class certificates were given to Mr. Keynes for Victory, maroon self; James Cocher, ruby, with a mauve tinge; and Flossy Williams, fancy, white, streaked and dotted with lilac; while Mary Keynes, cream tipped with purplish rose, had a first-class certificate. A similar award was made to Mr. Eckford, gardener to the Earl of Radnor, Coleshill, for seedling Verbena Peter William, scarlet with a large white eye, and large pips. Mr. Eckford sent several other fine seedlings. Mr. J. Douglas, gardener to F. Whitburn, Esq., Loxford Hall, Htord, sent seedling Gladiolus John Standish, a magnificent pale blush flower, having a small bright purple feather in the lower divisions. For this a first-class certificate was given.

Messrs. Stuart & Main, of Kelso, sent a number of blooms of seedling Pentstemon; and Mr. Porter, gardener to E. Benham, Esq., seedling Pentstemon.

Mr. Anthony Waterer, Knap Hill Nursery, Woking, was awarded a special certificate for beautifully grown plants of *Cupressus Lawsoniana erecta viridis*, forming fine pyramids; and accompanying these were *Cupressus Lawsoniana gracilis*, which is of a drooping habit, and a

basketful of a *Rhododendron* called *cheiranthifolium*, with very small narrow leaves.

Messrs. Standish & Co., of the Royal Nurseries, Ascot, were awarded a special certificate for a group of hardy shrubs, consisting of *Aucubas*, *Euonymus*, *Osmanthus*, *Janiperus*, *Retinosporas*, and *Cupressus nootkatensis variegata alba*, which, with several other of the variegated forms, was very effective. *Skimmia oblata* with its bright scarlet berries served to enliven the collection.

From Messrs. Lane came a seedling variegated form of *Cupressus Lawsoniana*.

Mr. Green, gardener to W. Wilson Saunders, Esq., Hillfield, Reigate, sent a small collection of Agaves, of which *A. Besserianna candida* with glaucous leaves had a first-class certificate. Mr. Green likewise exhibited *Gloxinia insignis*, and a very fine spike of *Acineta Barkeri*.

To Mr. Parsons, gardener to W. J. Blake, Esq., Daneshury, a first-class certificate was given for a pretty variety of *Athyrium Filix-femina* named *Blakei*.

Prizes were offered for twenty-four cut blooms of Asters. There were only two exhibitors—viz., Mr. J. Walker, nurseryman, Thame, and Mr. J. George, gardener to Miss Nicholson, Putney Heath, who received first and second prizes respectively. In the next class for twelve blooms there was more competition, stands coming from Messrs. E. G. Henderson, Mr. Walker, Mr. George, and Mr. Porter, gardener to E. Benham, Esq., Isleworth. The last three exhibitors took prizes in the order in which their names occur. In the different collections several very good blooms were shown, and the colours bright and well varied. All the blooms were French Asters with the exception of the first-prize twenty-four, in which there were a few quilled varieties.

Prizes were likewise offered for double Zinnias of six colours. The best came from Mr. Walker, the second best from Mr. Porter, but neither collection was up to the mark. In Stocks and Begonias there was no competition.

GENERAL MEETING.—Major R. Trevor Clarke in the chair. After the usual preliminary business, the Rev. M. J. Berkeley directed special attention to *Dendrobium chrysotis*, which, he said, bore a close resemblance to *D. fimbriatum*, and although the two differed in the spotting of the lip, and *fimbriatum* came from Nepal, while *chrysotis* was from Assam, yet those who were in the habit of studying plants would be inclined to think the two the same. *Gloxinia insignis* from Mr. Wilson Saunders's gardener was next noticed as very pretty, and as being known sometimes as *G. maculata*. Major Trevor Clarke had brought a flower of the true *Fuchsia coccinea*. The plant which had passed under that name was *Fuchsia magellanica*. Mr. Berkeley then read the following account of it given in the "Botanical Magazine," vol. xciv., t. 5740:—

"It will surprise many of our horticulturalists to learn that the plant now called *Fuchsia coccinea* in our gardens is not the first described species of that name, though it has borne it almost exclusively from within a year or two of the introduction of the real plant; and it may still more surprise them to know that the original *F. coccinea* is very rarely seen in cultivation. There is a story current amongst gardeners that the common *Fuchsia* was, when originally introduced, a greenhouse plant, but that it has become so far acclimatised as to withstand, without protection, the coldest winters of many parts of England, Scotland, and Ireland, and the milder winters of all Great Britain: be this as it may, it is not doubted that the *Fuchsia coccinea* was once treated as a stove or greenhouse plant, and now it thrives both in a greenhouse and out-of-doors. Now, when the true *F. coccinea* has changed its habits no one can say, for next to nothing seems to be known of its history between the date of its introduction as a greenhouse plant in 1788, and its re-discovery in the greenhouse of the Oxford Botanic Garden in 1877; the fact being, that the much harder *F. magellanica* was imported from wintry Terra del Fuego very shortly after the introduction of *F. coccinea*, and immediately usurped its name and spread it to every garden in the kingdom, whilst the true plant lingered in botanic gardens, lastly surviving (greatly to the credit of the Baxters, father and son) in that of Oxford alone. It may be more common abroad, and is almost naturalised in Madeira, according to Maudon.

"The native country of the true *coccinea* is unknown; it is probably Brazilian, as it resembles the Brazilian more than the Western or Southern American species; Salisbury says it was introduced by Vandell from Brazil, whereas Aiton attributes its introduction to a Captain Frith, from Chili.

"The evidence of the plant here figured being the true and original plant of Aiton's 'Hortus Kewensis,' ed. 1, rests on the fact that named specimens of the same are preserved in the Banksian Herbarium of the British Museum, and in Sir J. Smith's Herbarium at the Linnean Society, all procured at Kew in the year of the introduction of the plant, and at the date of its being described by Aiton.

"As a species, *F. coccinea* is much more graceful than any of the varieties of *F. magellanica*, flowers even more freely, and is readily distinguished by the almost sessile leaves with broad bases, and the lridy twigs and petioles; further, its foliage turns of a bright crimson when about to fall."

The new pest which had attacked the Vine was the next subject to which attention was directed. It was a pest which would almost be destructive to cultivation if spread as widely as the mildew, and in some cases it had done hundreds of pounds of damage. In 1867 he was at Lord Powerscourt's at Enniskerry, and Mr. Donn, the intelligent gardener there, pointed out to him (Mr. Berkeley), Vines affected by this insect, *Phylloxera vastatrix* (See vol. xvii., pp. 45, 46, where a description and figures of it are given). At first it seemed probable that the insect attacking the roots might not be the same as that on the stems, but he had come to the conclusion that the two were the same. He might say that Mr. Donn had discovered the only method

of destroying the insect, a plan which had proved perfectly successful. This consisted in taking the Vines up, removing all the soil from their roots, washing these three times in pure water, and then replanting in fresh soil. The winged male insects figured by Planchon, so far as he knew, had not been seen in this country, and it would be a great—in fact, a national, service, if anyone who saw them would forward specimens to Mr. Andrew Murray at the South Kensington Museum. Mr. Fenn's collection of Potatoes, particularly as showing the results of grafting, and the effects of the same operation as regards the Ribston Pippin Apple and the Blenheim Pippin, which have before been fully described in our pages, were then noticed; and, passing to the Tomatoes, Mr. Berkeley said, however good they were as a sauce, they made an excellent salad if cut in slices, and mixed with Water Cresses, a *sorquet* of Garlic or Shallots, a little oil, and plenty of vinegar. In conclusion, he reminded the meeting that on October 5th prizes were offered for collections of edible and poisonous Fungi.

Mr. Marshall kindly offered pollen of *Nepenthes Rafflesiana* to anyone who might be desirous of attempting hybridisation with these interesting plants.

BEDDING PLANTS IN 1870.

(Continued from page 179)

I WILL continue my remarks on bedding Geraniums by referring next to those that are grown for their foliage and not for their flowers.

To commence with the Tricolors, I still think Mrs. Pollock nearly as good as any for general effect. It is, no doubt, surpassed by many in regularity of outline as regards the zone, but I do not think our old favourite will be easily discarded. Lady Callum has a much darker zone, and a more brilliant colouring in the red of the zone, and is especially good in the spring and again in the autumn, but the colour, owing perhaps to the darkness of the zone, seems more bright in the height of the summer than either in Mrs. Pollock or Sophia Dumaresque. The latter and Flambeau, a variety sent out by Messrs. Backhouse, of York, and exceedingly like it, are both very effective bedders, with a more spreading habit than Mrs. Pollock.

Lady Headley and Attraction are both very beautiful wherever I have seen them, but I have not tried them as yet myself, but have seen none equal in colouring to Mrs. Headley as yet. Edith Pearson, a variety sent out by Mr. Pearson, of Chilwell, has a very soft and pleasing effect in a bed, but is surpassed by another variety of his, William Sunday, which I think he has not sent out as yet.

If we may judge from plants in pots, Prince of Wales, Mrs. Dunnett, and Fairland, varieties sent out by Messrs. Carter and Co., of High Holborn, are likely to be great acquisitions in the flower garden; and so is Ealing Rival, raised by Mr. Stevens, of Ealing.

Of these I have tried this summer (besides those I have previously mentioned), as Lucy Grieve, Sophia Casack, Louisa Smith, Queen of Tricolors, Lurline, and Spanish Beauty, I much prefer Lucy Grieve as one of the very brightest-coloured varieties I have yet bedded out, the red of the zone being very distinct, and lasting a long time before it fades. Louisa Smith has too much yellow, but is good in other respects. Spanish Beauty, on the other hand, is too dark, and Queen of Tricolors has orange instead of red in the zone.

Of the Silver Tricolors I cannot recommend any for bedding purposes. For pot plants I like Italia Unita, Pieturata, Caroline Longfield, Mabel Morris, and Mrs. John Clutton.

Of Golden-variegated varieties, as Golden Chain, Cloth of Gold, Crystal Palace Gem, &c., I still think, where it will grow, that none equals in point of colouring the old Golden Chain; it requires, however, manure and liberal treatment. Crystal Palace Gem turns too green with me; I have seen it very good elsewhere, but a self yellow-leaved sport from it has kept its colour better.

There are several self-coloured Golden varieties now, but much the best with me is Pillar of Gold; the leaves die off a lighter colour instead of turning green, and the young fresh leaves as they open are nearly pure gold; a line of it which I have under my windows in front of the house is very striking now. It is a good grower under proper treatment, but will not stand neglect.

Of the White-margined section I still like Flower of the Spring as much as any; it has such a compact habit, and fills the beds so well with the foliage. Miss Kingsbury is very good, but I do not see any great improvement, as I do not like the colouring of the green in the leaf so well, and the margin is not so wide and so well defined as in Flower of Spring. Alma is a desirable variety for larger beds. Bijou, though very white, has too upright a habit. Mrs. Lennox and Mountain

of Light are both very good in point of colour, but delicate in habit.

Of those I have not tried, but seen elsewhere, I prefer Mr. Turner's May Queen, an exceedingly effective variety, and Waltham Bride and Avalanche, which have the advantage of white flowers.

I turn next to the Bicolor or Gold and Bronze section, which in the hands of Mr. Laing, at Stanstead Park Nursery, made such rapid advances last year; and though we hear very conflicting statements as to their merit in the flower garden, yet I anticipate that when such sorts as *Impératrice Eugénie*, *Crown Prince*, and *Brilliance* become better known they will be largely employed. I have tried a great number of sorts this year—*Beauty of Oulton*, *Beauty of Calderdale*, *Model*, *Princess Alice*, and one or two others raised by Mr. Willis; *Ebor*, Messrs. Backhouse's; *Egyptian Queen* (Carter); *E. G. Henderson*, Mrs. J. Todd, Duke of Edinburgh, *Her Majesty*, *Golden Sceptre*, and *Bronze Queen*, most of which, I believe, were sent out by Messrs. Henderson; and *Kentish Hero*, *Black Prince*, *Brilliance*, *King*, *Charming*, *Countess of Kellie*, Mrs. Allan Lowndes, *Fairy Ring*, *Princess of Wales*, Mrs. Lewis Lloyd, and one or two others of Messrs. Downie, Laird, & Laing's. I begin by discarding all those that have too much tendency to turn green and have too much dark brown in the zone, as they run far too near in colouring to the old dark-leaved Zonals, as *Baron Ricasoli*, *Striking*, *Symmetry*, and others, and I select those that have true gold margins and discs with red or red-bronze zones. Of these *Impératrice Eugénie* is the brightest in point of colouring, and the leaves instead of turning green die-off a lighter colour, so that the effect from a distance is very brilliant. *Crown Prince*, Mrs. Allan Lowndes, and *Brilliance* approach nearer to *Impératrice Eugénie* in point of colour than any others, and the first named, *Crown Prince*, has vigour of habit combined with brilliancy of colouring. Of those that are gold and bronze—that is to say, with less red in the leaf, I like *Kentish Hero*, Duke of Edinburgh, *E. G. Henderson*, Mrs. J. Todd, and *Charming*. *Beauty of Oulton* very soon turns green. *Beauty of Calderdale* is effective when just bedded out, but is coarse in its habit and loses its gold colour in the summer. *Black Knight* is too dark in the zone. But there is another section with very narrow zones, and a great deal of yellow on the leaf which is very effective, but it produces more the effect of a yellow bed. Of these the best is Mrs. Lewis Lloyd, *Princess of Wales*, and *Golden Sceptre*. The first has a dwarf spreading habit, and will be very useful as an edging plant. *Princess of Wales* has a stronger and more upright habit; and *Golden Sceptre* has a less distinctly-marked zone, the old leaves scarcely showing the zone at all, but it has a very golden effect.

There is one secret in the management, they require liberal treatment, and they should always be kept growing, as the leaves when they become old, with the exception of those of *Impératrice Eugénie*, *Crown Prince*, Mrs. Allan Lowndes, and *Brilliance*, lose their colouring. If they are liberally treated they will stand any amount of sun, but shade is fatal to them. This is true with regard to all gold-leaved plants, but the reverse is true with regard to the white-margined sorts.

While on the subject of Bicolor or Gold and Bronze Geraniums, I must protest against their being shown, as is so often the case at country shows, as Variegated Geraniums. Variegation implies a sport. All our Tricolors and white-edged Geraniums were green Zonals to begin with, but the Bicolors have not changed since they were seedling plants. The mere fact of having two colours in a leaf does not constitute a variegation, otherwise *Baron Ricasoli* or *Lady Constance Grosvenor*, or any Zonal that is not self-leaved might be shown as a variegated Geranium. I could pick leaves at this present moment from *Beauty of Oulton* or *Her Majesty* which no one would distinguish from an ordinary green Zonal. I cannot again see that a Nosegay Geranium ought ever to be disqualified for competition among Zonal Geraniums unless there is a separate class especially mentioned in the schedule for Nosegays. A Zonal *Pelargonium* is classified by the leaf and not by the flower, and several of the hybrid Nosegays approach so near in roundness of petal to those that are commonly called Zonals, that I defy anyone to distinguish them if the individual flowers were taken from the truss, but they are still easily distinguished when on the plant by the size and shape of the truss and habit of growth.

Let me add as a postscript that I really am exceedingly obliged to the young ladies of *Geranium Cottage*, Benlah, for the wish expressed that I could see their beds of *Bayard* and

William Underwood. I should like also to see the young ladies themselves, and then, perhaps, I might be able to persuade them that *Waltham Seedling* is not the rubbish they imagine. I am sure of one thing, that at the time of the Metropolitan Florists' Show at the Crystal Palace the beds of *Waltham Seedling* were far the best Geranium beds there; and if they could at present see *William Underwood* in my garden, growing within a few feet of *Waltham Seedling*, they would be obliged to own there was no comparison between the two, as there is as much bloom on a square foot of *Waltham Seedling* as on a square yard of *William Underwood*. I have said before in my notes on bedding Geraniums that *William Underwood* is the best Zonal I have tried, but, like all other Zonals, it is too upright in its habit; and though it produces a good effect by close planting, yet it does not last. I do not know what are the Geraniums which the young ladies class as others as useless. *Bayard* is undoubtedly good; *William Thomson* and *Douglas Pearson* I have, and appreciate. And now, as they wish to alter the planting of their garden, I will suggest another plan besides that mentioned by the "Old Gooseberries." As with only thirteen beds in a garden, I should make no two alike, in order to have more variety, which adds much to the interest of a garden, though I should match my colouring so as to cross-balance as nearly as possible:—

- 1.—Centre vase.—*Arunco Donax variegata*; edge, *Impératrice Eugénie* Bronze and Gold Geranium and Blue *Lobelia*, plant for plant. Centre of bed, *Centaurea ragusina*; edge, *Alternanthera amabilis*.
- 2.—Purple King *Verbena*; edge, Golden Feather *Pyrethrum*.
- 3.—Miss Wimsatt *Verbena*; edge, Golden Feather *Pyrethrum*.
- 4.—Mrs. Pollock; edge, *Iresine Lindenii*, planted closely and kept pinched.
- 5.—Lady Cullum; edge, *Amaranthus melancholicus ruber*.
- 6.—Miss Kingsbury.
- 7.—Flower of Spring.
- 8.—Bayard
- 9.—Douglas Pearson
- 10.—Amy Hogg
- 11.—Dr. Hogg
- 12.—Centre line, *Centaurea ragusina*; edge each side, Violet Hill.
- 13.—Centre line, *Ciccaria maritima*; edge each side, Duchess of Sutherland.

If these beds are wide enough to admit five rows of plants, edge one bed with dwarf kinds of Gold and Bronze Geraniums and the other with small plants of *Pillar of Gold* or *Cloth of Gold*.

If 6 and 7 are enlarged and altered, as the Editors suggest, I should plant one with *Rose Rendatler* edged with *Miss Kingsbury*, the other with *Maid Kent* edged with *Flower of Spring*. I have discarded *Madame Kundershoff* as not good enough to go with the rest of the plants they have named.—C. P. PEACH.

WINTER-BLOOMING ORCHIDS.—No. 8.

PLEIONE.

This is a small but extremely beautiful genus, which, as I remarked in my former article, is often included in the genus *Cælogyne*. Beside the minute botanical differences between the two genera, they differ considerably in general appearance and habit; moreover, they are all deciduous and produce their exquisitely-marked flowers in winter whilst destitute of leaves. The majority of the species grow at elevations of from 6000 to 8000 feet in the forests of Nepal, Sikkim, and Bhotan, clothing the trunks and branches of the trees, and when in flower are said to present a most gorgeous aspect, causing the woods to appear all ablaze. They are mostly grown in pots, but succeed equally well upon blocks; in the latter way they require more sphagnum about them than most plants grown in a similar manner. When grown in pots, which is undoubtedly the best method, they should have ample drainage. The soil should be fibrous peat, sphagnum moss, and rich leaf mould in equal parts, adding a small portion of silver sand, but the curious little pseudo-bulbs should not be elevated above the rim of the pot, as in the usual method of potting Orchids. During the growing season moderate heat and an abundance of moisture are necessary to the development of large strong-flowering pseudo-bulbs; after these are formed they may be removed to a cool house and kept tolerably dry until the flower buds begin to show themselves at the base of the old bulbs, when additional heat may be applied with advantage.

P. HUMILIS.—Pseudo-bulbs some 2 inches high, in shape like little flasks, of a rich green colour, tinged with purple. Leaves narrow, acuminate, and dark green, turning yellow and falling off soon after growth is complete. The flowers are produced

singly; sepals and petals linear-lanceolate, white suffused with pale rose; lip of the same colour, fringed at the upper part, and traversed by six fringed parallel lines; between each of these lines is a streak of rich crimson. This lovely plant



Pleione humilis.

is in full beauty in the very depth of winter, and no collection should be without it. Native of Nepal.

P. WALLICHIANA.—In this species the pseudo-bulbs are somewhat different from those of the preceding, being elevated into a narrow point at the top, dark green and beautifully spotted with purplish crimson. Flowers very brilliant; sepals and petals rich bright rose; lip plaited, toothed at the point, of the same colour as the sepals, streaked inside with white and yellow, and splashed with crimson. This is a more attractive kind than the preceding, flowering usually early in spring—that is, from February to April. Native of the Himalayas.

P. MACULATA.—The pseudo-bulbs are about 2 inches high, and of a uniform dark green, the leaves in all the kinds being nearly of the same size. Sepals and petals oval and acute, pure white; lip white, blotched with yellow in the centre, where there are several crested parallel lines, and streaked with crimson in front. The charming flowers of this species are produced late in autumn. Native of Khasia.

P. LAGENARIA.—This is a gem amongst gems. The pseudo-bulbs are distinct from any other species, being flask-shaped



Pleione lagenaria.

with a peculiar overlapping neck. The flowers are large and solitary; sepals and petals narrow, deep rose colour; lip very

large, waved at the margins, white variegated with yellow and rich purple. It flowers profusely during the depth of winter. Native of the Himalayas.

P. HOOKERIANA.—At present this is somewhat rare in cultivation and difficult to obtain true. The pseudo-bulbs are from 2 to 4 inches long, ovate, smooth, and in colour bright green. Its leaves are dark green, and remain perfect until after the blooming season, considerably enhancing its beauty and rendering it very distinct from all the other members of the genus. Flowers large; sepals and petals oblong and pointed, rich bright rose; lip white suffused with rosy pink. A most elegant plant, flowering during the late autumn and early winter months. Native of Sikkim at great elevations.

P. REICHENBACHIANA.—This is a species of recent introduction, and which I have not yet had the pleasure of growing; judging, however, from its native habitat, I expect a greater amount of heat will be necessary to develop its beauty than is required by species from cooler regions. The pseudo-bulbs are between 2 and 3 inches high, bottle-shaped, with an obtuse top; ground colour deep green beautifully netted with brown lines. Flowers upwards of 2 inches in diameter; sepals and petals pale rose margined with white; lip white streaked and spotted with light purple, and crested on the centre. It blooms late in autumn and early in winter, and was introduced to this country from the mountains of Arracan.—*EXPERTO CREDE.*

WORK FOR THE WEEK.

KITCHEN GARDEN.

Pay every attention to the autumn *Broccoli*, also to autumn and winter *Lettuces*, watering them with liquid manure to make them crisp, and tying them up in regular succession. Let covering-up for blanching *Celery* and *Endive* proceed frequently. Brown and Bath Cos Lettuce, as well as the Hardy Hammer-smith Cabbage Lettuce for early spring use, should now be pricked out, especially if becoming what is technically termed "proud." Cut away all superfluous shoots on *Tomatoes*, and if the plants are gross chop away a portion of their roots.

FRUIT GARDEN.

Look frequently over fruit remaining out of doors and gather it as it becomes fit, as if allowed to become over-ripe it will be liable to be blown down and bruised should high winds occur; also examine frequently that stored in the fruit room, as a few decaying fruit will occasionally be found for a few weeks after housing, and they should be removed as soon as they can be perceived. Keep the fruit room cool and airy, in order to allow of the escape of moisture given off by the fruit; the amount is considerable for a few weeks at first. Occasionally examine Plums or any other fruit protected by covering, to see that they are not spoiling. Where it is intended to make any fresh plantations of fruit trees this season the ground should be prepared at the earliest opportunity, and any fresh soil to be used for planting should be thoroughly exposed to the action of the weather so as to have it in a mellow state when wanted. If not already done clean and dress Strawberry plantations, clearing away all useless runners and giving a good dressing of manure where necessary, but be careful to select that which is thoroughly decayed, and which can be covered without the necessity of deep digging or injuring the roots.

FLOWER GARDEN.

The weather has lately been most favourable for the flower garden; the masses of colour are most brilliant, and, but for the falling of the leaves, we might deceive ourselves into the impression that summer is at its height, yet in a few more days we may anticipate a nipping frost which will lay prostrate the glories of our flower gardens. As there are many plants of which it will be desirable to preserve some of the old stock for flowering next year, it will be necessary that they should be potted in well-drained pots and placed in close pits till somewhat established. There are these advantages in preserving old plants, that they cover more space, and flower earlier and more abundantly than young ones. Finish all propagation. Let all plants be secured from frost and placed in their winter quarters, if not already done. Now is the time to plant out young hardy Conifers; they will establish themselves before winter. Finish pruning and regulating your shrubberies. I recommend an annual pruning and thinning as conducive to high order. The late Mr. Loudon was of opinion that every shrub in a garden should be a specimen of its kind, and coined for this style the term *gardenesque*, in contradistinction to the picturesque of

nature in wild scenery. When annuals have sown their seed on borders a great portion of the young plants may be carefully retained; they will bloom early and strongly in spring, especially the Californian kinds, and may, moreover, be transplanted in February to desirable situations. Lawns should now be well attended to as regards mowing and rolling; and Dahlias, *Helianthemums*, tall *Phloxes*, *Asters*, and *Delphiniums* should once more be examined and sticked before October. Take off all layers of *Carnations* and *Picotees*. Those which have but little root should be potted and placed under glass like pipings; this is better than allowing them to remain on the parent plant. *Auriculas* may be set in their winter quarters, only covering them during heavy rain. When the soil is dry about Dahlias draw it up round the stems to protect them from any unlooked-for frost.

GREENHOUSE AND CONSERVATORY.

Housing tender plants will at this period occupy attention. Where pits or frames are at liberty, or can be made so by rooting up the remains of exhausted Cucumbers, Melons, and other crops, there is no absolute necessity for stationing every plant or tribe precisely where it is to remain throughout the winter. Protection of this sort for a short time will contribute more than houses to the production of sturdy and well-ripened wood, possessing a greater tendency to blossom, and more capable of enduring a severe winter than would otherwise be the case. In such places they must be secured from the earth worms. This is easily accomplished, especially when the frames are raised above the common ground level. A good soaking of lime water should be followed by a coating of cinder ashes 3 inches in thickness. Nearly all house plants, except, of course, stove plants and Orchids, may be kept thus until the early part of November, taking care to mat-up at night in suspicious weather, and to give abundance of air in the day. The glasses or lights should by all means be washed thoroughly. Such a course as here detailed will prevent the hurrying-off of late annuals, *Achimenes*, and a variety of other gay things, in order to make way for the winter stock. Towards the middle of October, if not before, the *Chrysanthemums* ought to be staged, and housing them is frequently the cause of a rearrangement of a considerable portion of other stock. Those who have a house or pit for everything will not need any advice on this head; the majority, however, are very differently situated. Continue in the conservatory to weed out flowers of a temporary character on the eve of decay, and to supply their places with good specimens. The introduction, however, of some of the hardwooded tribes which have been placed out of doors (unless they can be placed in temporary situations for a while) will fill many vacancies. Every attention having been paid to autumnal and winter Roses, as recommended in former calendars, they will now be found of great utility, both in this and other ornamental structures. In cases where there are many stove plants in this house, it will be necessary, in the event of the weather becoming cold and wet, to use a little fire heat; but be as sparing of this as circumstances will allow, particularly if there are other plants in the house likely to be injured by being kept too warm. In the latter case it will be advisable to dispense with stove plants, even at the expense of rendering the house somewhat bare of flowers, rather than to keep them there and, on their account, run the risk of injuring other plants. Be careful not to overwater plants brought from the stove; also use water at a temperature of from 70° to 80°, as watering with cold water plants that have been brought from a warm house injures the young and tender roots, shortens the duration of the blossoms, and often ruins the plant. Use weak manure water for *Salvia splendens* and *geraniiflora*, so as to preserve the plants in a vigorous state, and keep them blooming as long as possible. Give air freely on fine days, and thin out the twiners on the roof wherever this can be done with propriety, in order to expose the plants to all the light possible. In housing the out-of-door plants, be sure to place the *Geraniums* and forward *Cinerarias* where they will enjoy both light and air, and near the glass if possible. Hardwooded plants may stand farther back, except young stock of *Eriacs*, *Epacris*, and similar choice subjects. The Chinese *Primroses* will do in partial shade, and in the dampest part of the house.

PITS AND FRAMES.

Continue to afford young stock careful attention, and endeavour to have it well rooted and strong, without keeping it so close or warm as to render it sappy and liable to damp off on the first approach of wintry weather, as is often the case with stock raised in heat late in autumn, and then stored in cold

pits for the winter. Admit air freely to all plants that are rooted sufficiently to bear it without flagging.—W. KEANE.

DOINGS OF THE LAST WEEK.

THE rains have done good to everything, but the frosty nights after the rain have rather interfered with the brightness of the flower garden, the petals of many of the *Geraniums* looking a little bleached, and the larger leaves of *Coleus* looking brown.

KITCHEN GARDEN.

We said so much on the kitchen garden last week, that we shall confine our remarks to two or three matters.

And first as to watering. We have three inquiries if it would be of any use to employ sewage water, not too strong, to Celery, Cabbages, and Brussels Sprouts after the rains we have had. If the rains have not been much heavier than we have had, we say decidedly Yes, as they have not gone deep enough with us; and, again, we would prefer giving a good soaking of such sewage water in damp, drizzling weather, as the plants would derive much more advantage from it than in fine sunny weather, when a portion of the watering would again be soon exhaled into the atmosphere. A cloudy, drizzling day is the best for giving an artificial watering a good chance. Sewage water though rather strong, will not injure such plants when roofing freely, and greatly helps to keep many intruders away. The smell at first deters many insects from laying their eggs, and all crawlers will keep aloof if they can find sweeter soil. A late bed of Brussels Sprouts planted in dry soil, and merely moistened well in the drill when growing and rooting freely, grew as if by magic after receiving a good watering at the roots with sewage on a drizzling day, with a smart shower at times. When the sewage is at all strong, or smells very much, it is well to keep it off the foliage, but when not very strong it will do no harm over the foliage of common things if it be clear enough to leave no deposit. When clear we have found it good to syringe with, for driving away green fly and red spider. We have found it as effectual for killing aphides on Cabbages, Cauliflowers, &c., as clear rather strong lime water. But when so used it should be clear, so as to leave no mark behind.

Our Cabbageworts are now getting tolerably clear of the fly, which threatened to clear everything before it. We noticed a fine field of Turnips the other day almost destroyed by the fly, whilst others have suffered greatly from grubs. It would have been true economy in the case of the first to have used a dozen or score of barrelsful of clear lime water, or clear, not too strong, sewage, and, in the second place, to have examined the ground round the Turnips, as the grubs keep near the surface in their first stages.

Brussels Sprouts Early.—Our earliest are just showing, but not so early as we would wish. We have several inquiries like that of "A Friend," who says, "I sowed early, pricked out, and then planted strong plants early, and what with sewage and other waterings they have grown strong and tall with fine broad heads, but the side shoots, the sprouts, are only showing, and seem as if they refused to swell." To gain the desired object, the fine tops must be stopped. The simplest mode would be to cut them off, but that would entail a loss, as these heads, after a little frost, are even sweeter, when cooked like young Cabbages, than the little sprouts. When a severe frost occurs immediately after the cutting, and the stem at all splits at the cut part, the stem is apt to be injured. To prevent any of these disadvantages, and yet encourage the firm side sprouts to swell, with a sharp knife take out from the crown the central axis of growth. You will hardly notice that the little central point has been withdrawn, but it will soon tell in throwing more strength into the side-shoot sprouts all up the stem. For winter and early spring use Brussels Sprouts and Scotch Kale will yield the greatest and most profitable gatherings, with, perhaps, the exception of a fine old quarter of Cabbage, each plant now forming a large stool. Young Cabbages just hearting are now exceedingly sweet and tender after the rains.

Endive.—A good portion of ours was pricked out thickly, so that we could water and shade it, as we could not have found water for it if planted at regular distances in the dry weather. A portion of this we have turned out with good balls, so as not to suffer from the moving, on raised ridges, one row along the centre and two rows on each side. We find that on such ridges the plants withstand frost and damp much better than when on the level, and when well established, with a little moisture at first they grow as freely and as strongly as if they were placed

on the level ground. The most forward may be tied to blanch them thoroughly; but for this purpose early in autumn nothing is better than placing a slate or tile over the plants, or even setting a pot firmly over them, and closing the hole securely in the reversed bottom. Endive looks well in the salad bowl, but for crispness and sweetness we never think it equal to Lettuce.

Cucumbers.—The beds made, as stated last spring, with rather fresh dung, with a layer of sweet dung and leaves over it, have yielded plentifully all the season, and with little more attention than air-giving, watering, and fumigation with tobacco paper twice or thrice. To make the plants fruit a little longer the front of the bed outside the frame was dug out, and fresh hot dung put in as a lining, the back of the frame being merely banked up to the top of the frame. The back may be turned over in a similar way afterwards if deemed necessary. A rough spout in front of the frame kept the rains which run down the glass from passing into and decomposing the bed.

The plants turned out for the first crop in a hot-water pit have succeeded equally well, and are doing so well now that we let them remain, though properly a part should be replenished. These have very little earth to grow in, and that we curtailed by planting them out in largish pots. No pots, however, have been seen for a long time, as the frequent slight rich top-dressings have concealed them from view. The pots are chiefly useful for securing early produce, and even afterwards they do something to secure fertility and prevent the growth of large parasol-like leaves—a matter of no importance, but rather to be desired in large span-roofed or even lean-to-roofed Cucumber houses, but to be avoided in small lean-to pits, where such vigorous growth would occupy more room than is desirable. We have grown some rather large kinds this season, but in general they are not profitable where the room is narrow. We were told, however, lately that a very long kind which our neighbour Mr. Cadger has in his Cucumber house, and from which fine crisp fruit upwards of 3 feet in length has been cut, does almost as well in an unheated pit in summer. Large Cucumbers, however, are turned from by many people just as they turn away from a large Melon. They will scarcely believe that the one is not old and that the other does not partake of the Gourd. Those who like Cucumbers will do well to eat them when crisp and young. We like them to be not more than from three-quarters to 1 inch in diameter.

We are glad to say that we have here seen nothing of the *Cucumber disease* for a number of years. Some Cucumber growers have it still, and cannot get rid of it. Very often a road or a field will make all the difference between having the disease and being without it. As we have frequently stated, we now repeat, that after more lengthened observation, we are still quite ignorant of the causes that brought the disease to us for years, and we are quite as ignorant as to the causes of its leaving us. After trying all kinds, and having seeds from all quarters—after using all kinds of compost, from fresh loam, fresh peat, or heath soil, and almost every conceivable mixture—it mattered not, the only relief we found was to be almost constantly sowing and constantly planting, for frequently the plants would only produce a few fruit before the disease assailed them. All washings of the house and pits even with boiling water, all washings of the plants, were quite ineffectual. It mattered not where we grew them—in places heated by hot water, in dung frames, in cold pits and frames without artificial heat, in ridges under hand-lights, in the open air without hand-lights, trained against fences or walls, and with plants from seeds sent from healthy plants hundreds of miles apart—the result was the same. No sooner did the seeming healthy plants begin to bear than the spot in the leaf, or gangrene of the fruit appeared; then all was over with them, nothing would restore them to health again.

During several years that the Cucumber suffered we never had Melons more healthy. Several who felt inclined to make a joke over our trouble have felt it was no joking matter when they themselves were involved, and felt their thorough helplessness to get out of the difficulty. We mention this more prominently, as we understand there are employers determined on having plenty of healthy Cucumbers, however frequently they should change their gardeners. They may succeed in so doing. There may be something like fortunate men in gardening. Singularly enough there are men whose handiwork hardly ever turns out successful. We have little faith, however, in a change of management getting rid of the Cucumber disease. All that we can do is to sympathise with those who are the sufferers. We feel quite unable to tell them how to

conquer and get rid of it. To us it is a greater mystery than the Potato disease, because it is so partial, and continuous for a time in its local manifestations. We have known cases of neighbours equally successful in growing Cucumbers, and whose practical routine was as much as possible alike, and yet the one without altering in the least his practice will have the disease for years, and his neighbour not have a trace of it; whilst when the first has got rid of the disease without knowing how, his neighbour afterwards will have to regret the presence of the malady. Perhaps when we know more of atomic vital organisms we may be in a way to find out the cause of the malady. At present our observations and experience point to the conclusion that the best Cucumber-growers in the kingdom may get the disease among their plants without knowing how, and be as powerless to free their plants of it as the young amateur who grows a bed of Cucumbers for the first time.

FRUIT GARDEN.

We have had several inquiries as regards gathering Pears. Just as in the case of Apples, early Pears should be gathered before they are quite ripe, and later kinds when the seeds are coloured, instead of being softish and whitish. We like all to be gathered before they are touched much by frost; but late kinds that keep well, if gathered too soon, will be apt to shrivel before becoming sweet and mellow, though juicy.

We shall here advert to two sets of inquiries, How are we to make the most of early Pears, and also secure their best flavour? The first was alluded to last week, such as gathering the most forward of the earliest kinds, and even giving them extra heat without the chance of losing or evaporating their juices. Fine flavour is often lost by laying early fruit on dirty shelves, on straw or hay not thoroughly sweet, or even on brown paper. As the fruit ripens it absorbs a scent or aroma from the surroundings. Few plans are more simple than placing clean packing paper or foolscap on clean well-seasoned boards from which all scent of the wood has gone. On that paper place the fruit singly, and cover it with paper to prevent the evaporation of the juices, and along with them a portion of the aroma of the fruit. Open shelves or platforms answer very well, but such things as shallow boxes or drawers do better treated as above; the latter with just a slip of an opening to let any moist air out. We have known the finest fruit greatly injured by being laid on straw or hay not thoroughly dry, and not perfectly sweet, or liable to become damp from the moisture exhaled from the fruit. Late fruit may be treated less ceremoniously by being placed carefully in greater heaps instead of being laid singly, though the latter mode would be the better where room could be given; but as the most forward of these approach maturity they will be improved by being placed singly some time before using, and in many cases will be improved by being kept a little warmer, but not so much so as to sacrifice juiciness and flavour to mellowness.

The second inquiry has reference chiefly to a fertile source of disappointment at *country shows*. "JUNIAS" asks our help to unravel the mystery. He says, "I showed splendid large round Potatoes, but was beaten by kidneys of half the size; large Cabbages, but was beaten by smaller ones. I showed large Pears of Williams's Bon Chrétien rather ripe, Louise Bonne, and Beurré Bosc, and was beaten with small Bergamote not bigger than eggs; and in the same way my Cellini and fine Alexander Apples were beaten by small Kerry Pippins, and huge fruit of Victoria and Washington Plums were walked over by Green Gages anything but remarkable." The suitable reply is that most judges without specific directions award according to quality rather than bulk and quantity. We saw a man very wroth because huge round Potatoes with eyes nearly an inch deep, and therefore involving great loss if judged necessary to pare them, passed over, and the preference given to fine Mona Kidneys scarcely showing in their outline where an eye was placed. The remedy in such cases is to show in classes, such as round and kidney, white, and red, and other colours. The second remedy as to fruit is also to show in classes, such as for dessert, cooking, and even weight. For dessert nothing will beat Green Gage Plums if good, except fruit equally well ripened of Coe's Golden Drop. Fine specimens of such a dark rich Plum as Kirke's would run hard a dish of Green Gages if fault could be found with them. For table the Victoria and Washington would have no chance with them. Again, as to Pears, few kinds take so many prizes in autumn as the Bon Chrétien, but we have often seen it, when over-mellow and mealy, beaten by small fruit of the rich Bergamot just when in its prime, and both beaten by the Louise Bonne of Jersey when at its best.

The Cellini and Alexander Apples have no chance with the Kerry Pippin for the table, just as the little rich Apple would have no chance with them for the kitchen, and neither of them would have any chance with other Apples when size and weight were to be the criterions. Making classes is the only way out of the difficulty. Without it neither judges nor exhibitors will be satisfied. For instance, if amateurs were competing in Plums, we would give the preference to good Green Gages. Were cottagers competing we would have a hankering to give a preference to large Victorias or Washingtons. In this case, too, we should look on a huge Cabbage, firm and without cracks, in a different light from what we should look on a Cabbage destined for a gentleman's table. Size and weight should by no means be overlooked in the productions of cottage gardens, as what will fill the pot is of primary importance.

The wind of the 11th shook many fruit from all high orchard trees in this district, but it did comparatively little harm in the case of our bush and low pyramidal trees. When much planting of fruit trees is contemplated, and time and space are at liberty, it would be well to prepare for planting by trenching, station-making, &c. We have in unpropitious circumstances great faith in station-making, planting shallow, and yearly mulching, as securing fertility without much or any root-pruning. The sooner now that all weakly second growth is removed from fruit trees, the more will the sun and air have a chance to perfect the buds.

ORNAMENTAL DEPARTMENT.

The lawns are now lovely, perhaps all the more so when contrasted with the previous brownness; and notwithstanding the rains and the next to hurricanes of wind the flowers are still passable, though far from being what they were a fortnight ago.

We shall conclude our gossipings this week by alluding to two kinds of flowers which we can recommend as most useful to all those who from choice or necessity are obliged to supply a great quantity of cut flowers. Our own opinion is that cutting nice flowers to be put in vessels of all sizes and shapes, in all parts of rooms, to be thrown out in a couple of days, is not only carried a great deal too far, but that it is acting, and will continue yet more to act, most prejudicially on the health of the residents. Even a good and cheerful effect from moderation may easily be carried too far. But on this we shall not dwell at present, but where such flowers must be had in abundance, we would recommend the varieties of *Phlox Drummondii* and *Salpiglossis*. We think we had about a dozen varieties of each. We sowed them under glass in the middle of March, pricked the plants out in a bed under a little protection, then lifted them with little balls at the end of May, and planted them out. On an average the flowers of these will stand in damp sand four times as long as scarlet Geraniums.—R. F.

TO CORRESPONDENTS.

N.B.—Many questions must remain unanswered until next week.

Books (*E. S. S.*).—"The Fern Manual." It is published at our office, price 5s., free by post 5s. 4d. (*H. F.*).—"Fruit-Growing for the Many," can be had free by post from our office if you enclose five postage stamps with your address. It contains directions for Melon culture. (*J. B.*).—There is a volume called "The Language of Flowers." You could obtain it through any bookseller.

Kew Gardens (*C. J. P.*).—No preliminary examination is required of a young gardener before he can be employed in the gardens. If you write to Mr. Smith, the Curator, he will give you any information you need.

Dwarf Ageratum (*E. H.*).—We do not know the variety. Send a specimen to Mr. Chater, enclosing a stamped directed envelope, and ask him if it be true to name.

Phlox Drummondii Culture (*E. T. H.*).—The cause of your Phlox Drummondii not flowering well is its being under a south wall, where it would be parched with heat and drought. Had you given it an open situation and rich light soil, it would have bloomed well, if watered in dry weather. It is merely necessary to sow the seed in a hotbed in March, prick off the young plants when large enough to handle, placing them about an inch apart, and to plant them out at the end of May in rich light soil in an open situation. Phlox Drummondii Heyuheldi, scarlet; Kadowitz, striped; Oenata alba, white and crimson; are three good varieties, but all are very good. Mr. Chapman's cases may be seen at some of the principal London seedsmen's shops.

Hardiness of Echeverias and Sempervivum Californicum (*Nemo*).—The first two require to be taken up, potted, and wintered on a dry shelf in the greenhouse. They will need but little water. Sempervivum californicum is quite hardy, except when it has been grown in very rich soil, and then, from being very succulent, it is liable to be injured by frost. To winter it well, the soil should be light and properly drained. Take up a few plants, or all, and winter them on a dry shelf along with the Echeverias.

Spina Pear.—"Z." wishes to know the name of the Pear met with from the 1st of January to the end of March all along the south of France and in Italy. He was told, doubtfully, it is called "Spina."

CHRYSANTHEMUM LOUISE HONORARY (*Centurion*).—Your seedling plants about 5 inches high we would prick out now in a sheltered situation at about 6 inches apart, and leave them for the winter, cutting off the tops in spring. Early in summer place the plants in small pots, and shift into larger as required, giving the final shift by July. It is a hardy perennial Pompon variety. We do not think your plants will flower this autumn.

MISS INGRAM ROSE (*Idem*).—It is in every sense a Hybrid Perpetual, as much so as any other, but like some others of that class, is not a free autumn-flowering kind, though a beautiful Rose. Of the two Strawberries you name, there is none better than Dr. Hogg for a light sandy soil, but it needs good top-dressings and copious waterings.

PRUNING ROSE BOULE DE NANTERRE (*William Tyrer*).—We have no difficulty in getting this Rose to flower, and we cut in the strong shoots to six, the moderately strong to three, the rest to two eyes, except the very weak shoots, which we cut clean out. We do not know of any mode of keeping Tomatoes after they are ripe.

MILDEW ON ROSES (*Q. Q.*).—When mildew occurs on a few plants, try vinegar and a sponge. I cured my pot plants with it. It entirely removed it. When mildew occurs over the whole of a large rose, the cure becomes hopeless. Try in this case 2ozs. of blue vitriol dissolved in hot water, and added to three gallons of cold water; pour this with a rose over the leaves. Sulphur blackens the foliage, and stops up the pores or stomata of the leaves, causing for a time the same mischief as the mildew. Your attack is owing not to the mill dam, but to the situation and aspect, which, in such weather as we have had, are favourable to mildew. I have a little here. I cut off occasionally a twig, and destroy it, but when it occurs simultaneously over a large rose, it is a hopeless case. You must carefully wash out your watering-pot after using the vitriol.—W. F. RADCLIFFE.

ROSES IN POTS WEAKLY (*Thomas*).—Your very small Roses in very large pots we would at once shake out and repot in a compost of two-thirds fibrous loam, and one-third old cow dung or well-decomposed manure, with a free admixture of sharp sand, draining the pots well, and using a pot large enough to hold the roots, but not a large pot. Water the plants and place them on coal ashes in the cold frame. Admit air in mild weather, protect from heavy rains, and cover the lights with mats in very severe weather. Prune the plants rather closely when the buds begin to swell.

SEASON OF ENDIVE, RHUBARB, RADISHES, AND LETTUCE (*Idem*).—Endive is in season from September to April, and may be had from August; Rhubarb from November to July; Radishes from March to November; and Lettuce from March to November. You will need means for forcing the Rhubarb so as to have it in winter, and for blanching and keeping the Endive from frost, but for particulars consult "Kitchen-Gardening for the Many," price 4d., or free by post for five stamps.

GATHERING GRAPES (*An Amateur*).—As you do not require the Grapes after Christmas, you may leave them on the Vine. If your house is dry they will keep very well; but if it is filled with plants they will cause dampness, which will endanger the keeping of the Grapes. In the latter case we would advise you to cut the Grapes when they are fully ripe, retaining along with each bunch a portion of branch—say from 4 to 6 inches long; insert it in a narrow-necked bottle filled with water, and enough powdered charcoal to cover the bottom about half an inch deep. The bottle should incline to one side, so that no part of the bunch may be pressed against the bottle. The Grapes may be kept in any cool, dry room, where they should be looked over occasionally in order to take out any decayed berries, and to replenish the water when from evaporation it falls to a level with the end of the branch. By this means you can cut the fruit, and employ the house for plants, pruning the Vines at the proper season.—G. A.

CAMELLIA BUDS THINNING (*Idem*).—The shoots terminating with three or four buds should have the latter thinned to two each, and if the plants are weak one bud to each shoot is sufficient. The earlier this is done the better.

FORCING LILY OF THE VALLEY (*Centurion*).—The plants should be taken up and potted, selecting those with round plump crowns. If small and long, with sharp points, they will give little beyond leaves. You may take them up from now to March as required. They will flower at Christmas if potted at the end of October and introduced into a house with a temperature of from 40° to 45° for three weeks, and then increased or moved to another with a temperature of from 45° to 50°. Six-inch pots answer very well, but we use pans a foot across, and put in as many roots as we can. If they are an inch apart they are not too close. Over the pots, when placed in the house, invert another pot of equal size, and keep it there until the flower-stem is 3 inches long, then remove it. Any kind of light rich soil will answer very well.

APPLES (*Idem*).—The Apples you name are in season during the months of November, December, and January. Reine des Royales is distinct from Reine des Canadas. You would find complete answers to such queries in the "Fruit Manual."

GROWING ZONAL GERANIUMS IN LARGE POTS (*M. A. M.*).—You will, of course, take them in doors before frost, and in winter give them only water enough to keep the leaves from flagging, and if the old leaves fall off no matter. In March, or when the plants begin to grow, cut them in, leaving enough wood for furnishing fresh shoots, and do not water much until they have begun to grow. When they have shoots an inch or two long repot the plants, removing most of the old soil. If you can get them into a size of pot smaller than that in which they were grown do so. Keep them moist, but do not water very much until the roots are spreading freely in the fresh soil, as you will know by the growth of the plants, then water them more freely. In May transfer them to their full-sized pot. It will be necessary to tie down, stop, and otherwise regulate the shoots so as to form compact plants. A compost of equal parts of turfy loam and old hotbed manure, or leaf soil, with a free admixture of sharp sand, will grow them well. Good drainage is necessary. If your plants are bare of shoots near the base, young plants would be better, but they will not flower so finely nor be so large as the older plants. Try them again.

FRUIT TREES, STRAWBERRIES, AND ROSES FOR A GARDEN NEAR THE SEA (*M. G.*).—In a position not far from the sea, and fully exposed, we have succeeded on walls—Pears: Albertaine, Marie Louise, Beurre d'Etel, Beurre de Rance, Passe Colmar, Van Mons Leon le Clero, Knight's Monarch, Flemish Beauty, Glou Morcean, Bergamotte d'Espereon, British

Queen, Winter Nellis. *Plums*: Green Gage, Kirke's, Jefferson, Coe's Golden Drop; and for kitchen, Pond's Seedling, Victoria, and Prince of Wales; if a white Plum is wanted, White Magnum Bonum. *Cherries*: May Duke, Black Tartarian, Bigarreau Napoleon, and Late Duke *Apples*: Adams' Pearmain, Red Lustre, Golden Pippin, Cellini, Cox's Orange Pippin, King of the Pippins, Scarlet Nonpareil, Sykehouse Russet, and Kerry Pippin. *Strawberries*: Black Prince, Sir Joseph Paxton, Keens' Seedling, Dr. Hogg, Sir Charles Napier, Frogmore Late Pine, and Mr. Radclyffe. *Standard Roses*: Alfred Colomb, Anna de Diesbach, Baronne Prevost, Caroline de Sansal, Charles Lefebvre, Comte de Nanteuil, Duc de Rohan, Engoule Verdier, Jean Bart, John Hopper, Jules Margottin, King's Acre, Lord Clyde, Louise Peyronny, Madame Charles Wood, Marchal Vaillant, Prince Leon, Senateur Vaisse, Victor Verdier, Souvenir de Leveson Gower, and William Griffiths, all Hybrid Perpetuals. For walls: Gloire de Dijon, Climbing Devonians, Marchal Niel, Tea-scented; and of Noisettes: Jaume Desprez, Lamarque, Solfaterre, and Cloth of Gold. These require walls with aspects between south-east and south-west. For other walls and trellises: Alice Gray, Danco Rambler, both Ayrshire Roses; Myrtilles, Rimpant (Evergreen); Madame d'Arblay, and Rivers's Queen (Hybrid Climbing). In your light soil it will be necessary to manure well.

WINTERING PLANTS IN A COLD VINERY (Merlin).—To winter bedding plants safely you ought to have a stove or other means of keeping out frost. Though you will need artificial heat, it need not be so great as to cause the Vines to start into growth. A temperature of 40 from fire heat will not injure the Vines, and will insure the safety of every kind of bedding plant. Could you not have the house heated by hot-water pipes? A small saddle-boiler with a stove-hole outside would be better than a stove inside the house. There is no possibility of keeping bedding plants in a vinery unless frost can be excluded. Heat is requisite in dull damp weather for expelling damp, and would be useful for the Vines in a cold wet season. The Vines may be pruned at the beginning of December, or when the leaves have fallen. Pruning ought not to be deferred beyond the middle of December. The Vine border would be better if covered, but many borders are not covered, yet good Grapes are produced. It would be well to find another place for the annuals and to cover the border, but, instead of tarpaulin, for a cool vinery a top-dressing of rich compost and half-inch bones may be employed; but the annuals will keep the sun and air from the border, besides depriving the Vines of support.

FRUIT TREES NOT BEARING (Idem).—You will best restore your trees to fertility by taking them up this autumn as soon as the leaves fall, lifting each carefully and with a good ball, and replanting at once. The standards, which we presume are orchard trees, we would not lift, but merely thin out the shoots if too numerous, or, if not sufficient to form a good head, shorten the long vigorous shoots half their length. Why give the trees liquid manure when their growth is rank? With lifting in autumn you ought to check the vigour of the trees, and so induce fruitfulness. As regards the wall trees, we would take out the trench about 2 feet from the stem, cut off all roots there, and any roots that strike perpendicularly downwards between the trench and the stem, working under the roots. Then fill up the trench and mulch the ground, also that round the bushes, with 2 or 3 inches thick of short littery manure. Keep all shoots well pinched in in summer, except those required for extension. The Apple trees are infested with American blight. Syringe the trees well with a solution of 2 ozs. of soft soap to a gallon of water, directing it against the parts infested with the insects. You may obtain self-registering thermometers of most nurserymen, or of any optician. The cause of plants of Geraniums and Fuchsias losing their leaves when taken into rooms is the want of sunlight; by retaining their freshness longer when taken from the open ground may be a result of their greater hardiness.

VINE PLANTING (Reader).—We see no objection whatever to your planting your Vines in the autumn instead of the spring or summer, and just because the ground would be warmer we would prefer planting in September rather than in October. As they are to be planted inside protection is less necessary, but even then the longer the soil is kept warm the more will roots be made after planting. If the roots were out of doors we would cover with litter deep enough to keep out frost, cold rain, and snow. We have planted Vines that grow freely in June and July. In these summer months, if there is much spreading-out of roots, there is apt to be a check if not guarded against.

BLACK MUSCAT GRAPES (W. M.).—Our experience of Mrs. Pince's Black Muscat Grape is very much in accordance with your own, and we regret to say it is almost universally so. The bunches, as you observe, do not set regularly, neither do they colour very freely. Both the bunches and the berries are large, and the latter of excellent quality; it is of considerable merit as a late-keeping variety. It is one, however, which, in our opinion, has been far too much lauded, and altogether unworthy of extended cultivation. In marked distinction to this we have Madresfield Court Black Muscat, which is in all respects excellent, and we have seen it in many places this season. It is possessed of all the qualifications of a good late Muscat black Grape, splendid constitution, free fruiting, large bunches and large berries, fine jet black colour, and good Muscat flavour—truly a meet black companion for the white Muscat of Alexandria. We strongly recommend this Grape. Muscat Champion is a very fine, large grizzly Grape, with a Muscat flavour. When well grown and ripened it is excellent, but, like the Canon Hall Muscat, it is somewhat difficult to secure it in this condition.—A.

VINES (W. G. C.).—Mrs. Pince's Black Muscat is not suited for a cool vinery. Muscat Hamburg grafted on the Black Hamburg succeeds only moderately well in a cool house. All Grapes having the Muscat flavour require best to bring forth the mnsky tastefully. The Frontignan class (the Petites Muscats of the French), require the least. Mrs. Pince is a good-keeping late Grape, but we much prefer the Madresfield Court Black Muscat. Your selection of Peaches is very good. For the Nectarines, however, we should prefer Elruge and Balgovan as two of the best and most constant varieties grown. The fruit on Black Hamburg Vines as they are commonly met with varies considerably according to cultivation. The variety called Frankenthal has large roundish oval berries, hammered, the bunch well shouldered and compact. The true Black Hamburg has smaller berries, more oval, smooth, with a more loose and straggling bunch. We should say you distinguish them properly. The third variety is the Dutch; berries very large, round, and hammered, very coarse in quality, but beautiful in appearance. We should say this is the one you have. The Champion or Millhill has very large, round,

smooth berries, which scarcely ever become quite black, and have a very tender skin and fine flavour. It is of delicate constitution.

SELECT APPLES AND PEARS (A Poor Lady).—The following may suit you. *Autumn Apples*.—Cox's Orange Pippin, Kerry Pippin, and 1 Summer Whorle. *Pears*.—Williams's Bon Chretien, Beurre d'Amanlis, and Jersey Gratiosi. *Apples for April and May*.—Scarlet Nonpareil, Golden Reinette, Braddick's Nonpareil. *Pears*.—Ne Jplais Meuris, Zephirin Gregoire, Josephine de Malines.

HARDINESS OF CINERARIA MARITIMA (B. G.).—It is quite hardy on all but very heavy wet soils, and in very exposed situations. We find it does best when the old tops are left, as they to some extent protect the crowns from the severity of the winter, and to make all safe we generally mulch round the plants with partially decayed leaf soil. The tops are cut off in winter by the frost, so that the plant is not one to be recommended for spring gardening, or not until late. It is best in summer. The dead tops should be cut off in spring.

ECHEVERIA SECUNDA GLAUCA (Idem).—It is not hardy, nor will any of the Echeverias stand the winter. Sedum, or Scimpervivum californicum, however, is quite hardy in dry soils and favourable situations. It is a fine plant for edgings.

NAMING APPLES AND PEARS (Idem).—If you send them to us carriage paid, and each kind numbered, we will endeavour to name them for you. Half a dozen will be enough to send.

HOYA CARNOSA FRUITING (Charles Walters).—It is rather unusual for this plant to have pods, but there have been several instances this year of its fruiting; indeed, such are becoming general. The cause of its doing so is, undoubtedly, the bright weather we have had.

ASPARAGUS MANAGEMENT (Glaucous).—Your three-year-old plants planted last autumn could not be expected to give you any heads fit for cutting last spring, and we think they will not do much for you next year, though you may cut all the heads that are of a size fit for cutting, and let the small grow; but we would advise you to be satisfied with a little next season; the produce will be quite yellow, and cut it off early in November. Clear the bed of weeds, give a top-dressing of manure 2 or 3 inches thick, and cover about half as much with soil from the alleys. If the manure be only partially decayed it will do. In March remove the loose portion of the manure, or point the beds over with a fork, not going so deep as to interfere with the crowns, and rake the beds, drawing the rough soil into the alleys. At the end of March sprinkle the beds with salt, and again in May, in the same way as you would for destroying weeds on walks; and from July to the middle of September you cannot water too freely nor too often with liquid manure. In the following spring you ought to have a plentiful supply of heads.

TOUS-LES-MOIS (Indicus).—We cannot tell you where you can obtain the seeds of the plant from whence this flour is obtained, but probably through some West India merchant. Dr. Herz, in his "Vegetable Kingdom," says, "The article known as Tous-les-mois is obtained from the root-tubers of some species of Canina, by some supposed to be *C. coccinea*, and by others *C. acurata*. The substance is prepared in the island of St. Kitts, and it is said that its manufacture is attended with a great deal of difficulty; it is highly nutritious, and is an excellent food for infants."

CATEPILLARS ON GERANIUM AND STACHYS LANATA LEAVES (E. M. T.).—There is no better plan than to boil fresh Elder leaves in as much water as will just cover them until it is quite black, then strain, and water the plants overhead when quite dry through a fine-rosed watering-pot, giving a good wetting. Dusting with white hellebore powder will serve the same purpose. Handpicking is an excellent remedy.

VARIEGATED GERANIUM LEAVES (Kittie).—We do not undertake to name florists' flowers, and it is extremely difficult to identify the variegated varieties by their leaves; but we think yours are—1, Silver Nosegay; 2, Flower of Spring; and 3, Flower of the Day.

PYRUS JAPONICA (S. T. H.).—We do not know of any economical use to which the harsh and gritty fruit of this Quince can be put.

FLOWER GARDEN ARRANGEMENT (Rush).—We like the arrangement very much, and are pleased you have the boldness to make the four beds round the centre similar, as we believe attempting more variety would not be so effective. As you ask particularly about 5 and 6, we should be inclined to reverse them, as the four 2 beds have Golden Chain round them; we would therefore plant 5, 5, with Madame Rudersdorf, and edge with *Oxalis corniculata rubra*; then we would edge 6, 6, with *Cerastium*, and fill with Mrs. Pollock, dotted all over with *Lobelia*.

SEEDLING PLUM (W. Miles).—Your seedling Plum, although good, is so similar to others already in cultivation, that we can see little use in introducing it. It is inferior to the variety called Poupert's, which it somewhat resembles.

BERGAMOTTE D'ESPEREN PEARS (Lang).—Let them hang on the trees as long as they will, say till the middle of next month. When they come off freely is the time to gather.

ROSE BUDS (Idem).—It is somewhat late now for budding; you may, however, try. They might do on the Manetti stock.

SIFTED LIME RUBBISH FOR A LAWN (H. S. W.).—For a lawn liable to get scorched in summer lime rubbish would be the worst possible application. We should give a top-dressing of rotten manure next March, rake the lawn well in April, and sow over it Trifolium minus at the rate of 12 lbs. per acre. It is not so liable to brown as grass is in summer, besides it is always of a bright deep green. Its drawback is its numerous small white heads of bloom, but run over with the mowing machine once a week all is kept neat.

APPLYING LIQUID MANURE (A Constant Reader).—Manure water to be of any benefit should be given when the plants are growing, or during summer. It may be given from the commencement of growth up to its completion, but will not be needed in wet weather.

PLACING FLINTS AROUND THE STEMS OF SHRUBS (Idem).—The practice was recommended by London partly to keep the ground near the stem from being disturbed, and to prevent weeds growing, and to afford warmth; but as the flints can do no good in any of those ways in protected or enclosed grounds, we think it a needless proceeding.

EAST LOTHIAN STOCKS AFTER FLOWERING (Q. Q.).—The plants will not be of use for next year's flowering, but if you wish for seed you may pot them, and winter them in a cold frame. That is the only purpose for

which they are fit. They will not live out of doors except in a warm dry soil and situation.

ASPARAGUS PLANTING (*Idem*).—You may in October plant in the permanent bed, and after planting cover with the top-dressing of manure as for established plants. It would be better if you could defer the planting until spring.

SOWING GRASS SEEDS (*N. C. H.*).—The seeds sown last week will not suffer from frost, and as far as the covering with stable litter as soon as the grass shows, it would do more harm than good; but were it put on thickly before very severe weather sets in it would prevent the soil lifting, and so be a great protection to the Grasses and Clover.

SOWING TRIFOLIUM INCARNATUM AND ITALIAN RYE GRASS (*Idem*).—We have known them succeed well from sowing in the first week in October, but the season was mild. That we consider is as late as they should be sown, and we would if possible sow in September. The earlier the better for early spring cutting.

DRYING FLOWERS (*W. Y.*).—Everlasting flowers should be gathered as soon as fully expanded, and dried by hanging up in a dry warm place. To dry other flowers take some fine white sand (that called silver sand is the best), wash it repeatedly until all dirt is removed, and the water remains clear. Next dry it thoroughly, and half fill a vase, a stone flower pot or a glass with the sand; in this stick fresh-gathered flowers in their natural position, and afterwards cover them gently with the sand, taking care not to damage the petals. Now place the vessel in the sun, or in a room where a constant fire is kept, and let it remain until the flowers are perfectly dry. Then remove the sand carefully, and clean the leaves with a feather brush. You must gather your flowers for this purpose when they are dry—that is, after the dew has evaporated. The process succeeds best with single flowers, but the difficulty attending such double ones as Pinks, Carnations, &c., may be avoided by splitting the cup on each side, and when the flower is quite dry the incision made to adhere by means of gum water; or the cup may be pricked around with a pin to let out the moisture. White flowers lose their natural colour by this process, but it may be restored by exposing them to a moderate vapour of brimstone; but crimson or scarlet flowers should be placed in a vapour of the solution of tin in spirits of nitre. The green leaves and stems are renovated by the vapour produced from a solution of steel filings in oil of vitriol. When dried the scent of each particular flower may be artificially renewed by dropping into the middle of it some of its essential oil: thus oil of Cloves will scent the Pink, oil of Roses the Rose, oil of Jasmine the Jasmine, &c.

REPORTING FINE PLANTS FOR NEXT SCHIMMER'S FRUITING (*W. S. S.*).—We should have potted the plants in August into their fruiting pots, and placed them low, so as to allow for top-dressing; but that not having been done, delay potting until February, and then shift into the fruiting pots, not discarding the plants, nor removing more of the old soil than will come away freely. Encourage growth with a brisk bottom heat and moist atmosphere, but do not water very freely until growth is vigorous.

SCARLET RHIBARBE (*W. C.*).—All properties considered, there is no finer scarlet or red Rhubarb than Tobolsk, or small Old Red. It may not suit the cook, but it does the table. An improved form of it is Baldry's Scarlet Deference. It is larger, and possesses all the other good qualities. Salt's Crimson Perfection, which you have, is also good.

CHRISTMAS ROSE (*Nuss*).—This (properly *Helleborus niger*) is quite hardy, and succeeds in any soil, but best in one which is well drained, light, and enriched with vegetable soil, such as leaf mould. It is propagated by dividing the roots or plants into as many parts as you can make with roots and crowns to each. This is best done in spring, though we have divided the plants very successfully at this time of year. It is desirable to give the plants a position shaded from the direct midday sun in summer; hence an east is preferable to a south border.

RED-FLESHED MELON (*Idem*).—Malvern Hill is a fine scarlet-fleshed Melon of delicious flavour.

APPLYING GAS LIME, SALT, AND SOOT (*W. L.*).—Gas lime is so powerful that it should not be applied to garden ground except in small quantities, and to that not required for cropping for some time afterwards. It should be spread evenly on vacant ground in November or February, and be dug in; indeed, in gaudous as a manure it is best not to use it, though for making the ground obnoxious to insects feeding on the roots of plants it has been found useful. Twelve bushels per acre are ample to effect that, and all we advise. Salt is beneficial as a manure. It should be sown broadcast over the ground in spring. Twelve bushels per acre are sufficient. Soot is a good manure sown broadcast in spring during moist weather. Sixteen bushels per acre are enough. It may be used along with salt, and at the rate of ten bushels to six bushels of salt. This mixture is found excellent as a manure for Potatoes, and would probably suit most vegetable crops.

EXTIRPATING HORSEWEED, BINDWEED, AND CATCH GRASS (*Idem*).—For destroying Hor-etal there is no remedy but draining. Drain the ground and it will disappear. The Bindweed is only to be destroyed by forking or digging the ground over deeply, and picking out the roots, which, though a tedious, is a sure process. In summer keep the tops pulled up as fast as they appear, which will prevent the roots increasing much. Couch should be forked out; indeed, in gardens there ought to be none. Whenever a blade appears fork out the roots.

CHARRING REFUSE (*N. A.*).—No letters have been received from you before. The article you refer to is in No. 474. If you enclose four postage stamps with your address it will be sent to you by post. It is too long and too recent to reprint. It is impossible to name Strawberries from the characteristics you give, they vary so much with soil and season. If you send specimens of the fruits we can aid you.

ZINC EXPOSED TO FIRE (*H.*).—We do not think a tank made of zinc would long resist fire heat under it. Gas heat would not so soon affect it if the flame were not very near the zinc, but the alternate expansion and contraction from heating and cooling soon destroy a zinc vessel. A small gas stove, or an argand jet in a confined place with a slit to admit air, would be quite sufficient for such a small tank. If you wanted the tank for propagating, and thus getting bottom heat, 3 inches deep would be better than 5 inches.

FLECK-HEATING (*East Leamington*).—For such a flue as you describe you want no damper; regulate draught by the ash-pit door. To succeed, see that the furnace-bars are from 18 to 24 inches lower than the bottom

of the flue. If your inside border is well made, and is 13 feet in width, there is no reason why the Vines should not flourish planted inside if they were timeously watered and surface-manured. It is awkward having the house so situated that snow resting on a slate roof, when it slips, would slide down on the glass roof, for if at all heavy it would go through the glass. A barrier about 13 or 18 inches in height between the slates and the glass would prevent or lessen the evil. In a similar case where a barrier would be unsuitable, we have used wooden shutters, or even shutters or covers of sparred wood to lay over the lights where the snow was apt to fall, and thus saved the glass. It is seldom that would be wanted except in heavy snowstorms.

HEATING BY GAS (*P. S.*).—If you buy No. 311, where drawings are given of gas stoves, you can select which you please. You can have it by post if you enclose four postage stamps with your address. We do not know how you manage your stoves. Could you increase the number of burners? and then, the piping being increased, you would get more heat. Argand burners give a great deal more heat with less consumption of gas than common jets. We presume your gas goes through the 1-inch piping. We would be glad to assist you if we knew how.

VANTORS (*J. quintin*).—You will not have any extra heat in a span-roofed house 14 feet wide that has only two flows and one return-pipe. However, if it does for Strawberries from the 1st of January to the 1st of July, it would do admirably for Melons from the 1st of July up to the end of October, and for Cucumbers until towards the end of November. The uses to which such a house may be put during the six months are endless, but as we do not know what you chiefly want, it would be idle to particularise them; but we may mention growing tender annuals, Capsicums, Chilies, &c. You plan of getting Strawberries at Christmas has often been tried, often succeeded, and oftener failed. We have gathered good dishes on Christmas-day, and we have hardly had any when we tried for them. Success greatly depends on the end of November and part of December being bright and sunny. It would never pay to force so early generally. By your proposed treatment the plants would be matured and rested early, but even in such cases our success has not been uniform.

NAMES OF FRUITS (*Constant Reader*).—Your Pear was quite rotten. (*A. Noyce*).—Pears: 1, Nonvent Poiteau; 2, Passe Colmar; 3, Beurré Diel; 4, Grou Morceau; 5, Beurre de Rance; 8, Beurre Diel; 12, Susette de Bayay. (*H. M.*).—Plum: Smashed all but a small portion of one end, which had the appearance of Prince of Wales. (*H. L.*).—We have some difficulty in determining your sorts: 1, Not known; 2, English King's Pearmain; 3, Pine-Apple Russet, probably; 4 and 5 are the same—we think Munchie's Pippin, certainly not Irish Peach. (*P. M.*).—Plums: 1, Belle de Septembre; 2, Diamond; 3, Gisborne's, very fairly grown. (*W. Miller*).—Apples: Your specimens are so very small and scrubby, many of them no larger than small Crabs, possessing no characteristic features, that it is quite impossible to name them. We think 21, 34, and 35 may be Hawthornden; 14 and 30, Court of Wick; 15, Cole; 32, Golden Harvey, or Harvey Russet; 24, Sam Young; 1, Baxter's Pearmain; 8 and 9, Scarlet Nonpareil. (*Walsam Court*).—Your Peach—1 A, looks like Bellegarde, but we cannot tell without knowing the character of the flowers and leaves. Nectarine 4 D, is Elruga; 5 F, Red Roman, a clingstone, which is rather apt to fall in a semi-ripe state. Fig 3 C, is Brunswick; 2 B, Brown Turkey. (*W. Kerr, Dumfries*).—Your Apple is, we believe, Bateborodova.

NAMES OF PLANTS (*W. T.*).—We cannot name plants from their leaves only.

POULTRY, BEE, AND PIGEON CHRONICLE.

PRIZE CUPS FOR BRAHMA POOTRAS AND COCHIN-CHINAS AT THE PLYMOUTH SHOW.

In following the very spirited example of several gentlemen connected with other shows, I hope I may be at least as successful in obtaining subscriptions sufficient to provide two silver cups for the best Brahmas and Cochins at the forthcoming Plymouth and West of England Poultry Show. The admirers and breeders of the above varieties are apparently scarce in the more western counties of Devon and Cornwall, and it is hoped that the inducement thus held out will not only bring together a collection of specimens superior to those hitherto exhibited at Plymouth, but contribute in some degree to the greater and more successful cultivation of the Asiatic breeds, which are at once the finest and hardiest birds in the poultry-yard. I may add that the two cups usually added by the Committee will still be offered for the best specimens in the Show, irrespective of the subscription cups. Any gentleman intending to subscribe will greatly oblige by communicating his intention to me as early as convenient.—JAMES LONG, 23, Princess Square, Plymouth.

ANTWERP PIGEONS.

WITHOUT wishing to disparage the claims of any of the beautiful varieties of the domestic Pigeon now cultivated, I would say to those about to enter upon the Pigeon fancy, who are undecided what particular kind to keep, Try the Antwerp. It is as hardy as any, more prolific than most, and for beauty of plumage and sprightliness of carriage will bear comparison with any other variety, in addition to which it is more sensible than any other breed, and when once settled to a particular locality is not readily lost.

There is no necessity for building an expensive house with a southern aspect for its reception, any spare corner in an out-house will do—east, west, north, or south, it is quite immaterial. Having selected a convenient place, build a pen about 5 feet high, 10 feet long, and 3 feet deep; at each end fix shelves a foot deep and about a foot apart, placing a division in the centre of each, which will give two nesting places on every shelf. These should be supplied with loose boxes about 9 inches square and 3 inches deep. In the blank spaces between the rows of shelves, and at the back of the pen, fit up about a dozen rests for the birds to perch upon, of any description, according to fancy. The old-fashioned triangular shape is as good as any. A pen of this size will hold ten pairs of birds comfortably. The aperture for egress and ingress may be put in the most convenient place, and should be fitted with a bolting wire to prevent the birds getting out at will.

Next select your birds. If you want good ones I would recommend the purchase of old birds to breed from. Pay a visit to any genuine fancier who keeps birds for the love of them, and not entirely for profit. I never found such a one that was not pleased to show his birds, and to tell the distances the different birds had flown, together with their pedigree, and every particular connected with them. Select a pair to your fancy, and if for sale do not be to a shade as to price. Visit another fancier in like manner. Cut the birds down and cross-pair them, by which means you will avoid in-breeding, and stand a fair chance of getting good young ones, but this will by no means be a certainty. There cannot be a greater mistake than to suppose that because you mate good old birds the young produced will, as a matter of necessity, be good also. I have mated first-class birds for homing purposes, and the young produced have been worthless. If your birds do not "hit," you must change the old ones till they do, otherwise you will never have a pen of good Autwerps, as unless the birds possess the homing faculty to an average degree, they are not fair representatives of the breed, although they may have all the outward points required in a good bird. You may breed any colour; but Dun, Red Chequer, Blue, and Blue Chequer, are the only colours recognised by standard breeders. I prefer a pen of birds to match in colour, and if well matched it is difficult to decide which colour is the most attractive. The Light Duns, with bright red bars on the wings, and red necks, are certainly as handsome as any; Light Blues, with good black bars on the wings and tail, and rich metallic lustre on the neck, are also very pretty.

When you wish to try your young birds do not commence with them too early, let them be from four to five months old; they may then be thrown up a mile or two from home, and it will soon be seen which are likely to make good homing birds. If, when tossed up, a bird hangs about the place where it is loosed, flying low, and without spirit, ultimately dropping upon some convenient building, or with other birds, condemn it at once, and should it return home kill it without hesitation, however handsome it may be; if, on the contrary, the bird when tossed from the hand gets well up in the air, ranging wide, and flying resolutely, not taking notice of any birds that may be put up to it, there is every probability, if properly trained, that it will make a good bird.

I find it an excellent plan to clean out my birds' pens daily; it occupies but a few minutes, if a scraper similar to those used by pig-killers be kept for the purpose. Keep a barrel of sand near the pen, and after cleaning sprinkle a few handfuls on the bottom and at the front of the nesting places, this gives the pen a neat appearance, and conduces much to the comfort of the birds. Exercise your birds once daily—morning is the best time—and they will soar as high as Tumblers, flying from twenty to fifty minutes, and sometimes much longer; when they alight allow a little time for gritting, and to run the building, then whistle them in and feed, giving just as much as they will pick up freely; feed again about four o'clock, giving clean water daily. By these means your birds will be kept in constant health, and from their lively disposition and neat appearance will be a source of constant pleasure and amusement.—B. F. C.

CURE FOR ROUP.—I send you below a valuable receipt for the cure of roup in chickens. I have used it in over one hundred cases with complete success. The pill should be made as per enclosed sample. I consider the form of the preparation as important; it should be put into a gelatine capsule, otherwise it is very difficult to administer. Balsam copaiba 1 ounce, piperine 1 drachm, made into sixty pills, and give two or three every day. Wash.—A teaspoonful of sugar of lead, mixed with a

pint of water, for bathing the eyes two or three times a-day.—WALTER LAWRENCE.—(Poultry Bulletin.)

NORTHAMPTONSHIRE AGRICULTURAL SOCIETY'S SHOW.

REGARDLESS alike of trouble and heavy outlay, the Committee were determined to make the meeting held on the 15th and 16th inst. a success, and their anticipations were realised. A spacious tent and all the internal arrangements in the hands of Messrs. Turner, of Sheffield, brought an exhibition such as never before took place in Wellington. Old and young birds were shown in distinct classes. The adults were in deep moult; the chickens, on the contrary, being in the highest show trim possible. *Dorkings* and *Cochins* were unexceptionably good, and the cup-winners, as in most of the other classes, had to obtain their success in a severe competition. The *Ham-burgs* were, perhaps, the least praiseworthy classes in the whole Show; but the exhibitors of *Buenos Ayres* *Ducks*, *Laced Bantams*, and the various breeds of *French Fowls* deserve every expression of favour. *Pigeons* were shown in collections of three pens each, and certainly among the twelve pens exhibited by the four competitors were birds of great value and purity of breed. This portion of the Show proved a great attraction to the ladies, who, as the day was fine, congregated in the poultry tent in extraordinary numbers.

DORKINGS.—1 and 3, R. Wood, Clapton, Thrapstone. 2, H. Lingwood, Needham Market. **COCHINS.**—1, R. Wood, 2, H. Yardley, Birmingham. 3, J. Beasley, Chapel Brampton. **HENS.**—1, J. Longland, Grandon. 2, H. Lingwood. 3, H. R. Wood. 4, T. Furnaby, Pine-well. **CHICKENS.**—1, H. Lingwood. 2, J. Smith, Shillinglee, Petworth. 3, H. Yardley. 4, J. Longland. 5, J. K. Fowler, Ayles. **BIRDS.**—R. Sykes, Goldington, Kettering. 2, C. B. Charlis, Clendon, Kettering. 3, R. Wood. **POULTRY.**—1 and Cup, J. L. Malden. 2, J. Wood. 3, J. Longland. 4, R. W. B. Davies, Moseley Hall, Birmingham. 5, H. Yardley. **W. A. Taylor.** 1, J. K. Fowler. 2, J. Beasley. 3, J. W. A. Taylor. 4, W. A. Taylor. 5, J. K. Fowler. **HENS.**—1, W. A. Taylor. 2, H. Lingwood. 3, J. Stephens. 4, J. N. Peasley, Northampton. 5, T. Dufford. **CHICKENS.**—1, W. A. Taylor. 2, J. Stephens. 3, J. K. Fowler. 4, T. Dufford. 5, J. Beasley. **HAM-BURG (Any variety).**—1, B. Cox. 2, H. Yardley. **BANTAMS.**—1 and 2, M. Leno. 3, C. R. Heston. 4, J. Stephens. **ANY OTHER VARIETY.**—1, W. A. Taylor (Dark Bantam). 2 and 3, J. K. Fowler (French). **GEES.**—1, J. K. Fowler. 2, S. Deacon. **DUCK.**—1, J. K. Fowler. 2, J. K. Fowler. 3, J. Beasley. **FOWLS.**—1 and 2, H. R. Wood. 3, J. K. Fowler. **ANY OTHER FOWLS.**—1, M. Leno. 2, J. N. Peasley (Buenos Ayres). 3, J. N. Peasley (Buenos Ayres). 4, J. Goodlie (South Carolina). **TURKEYS.**—1, J. N. Peasley. 2, J. Craig, Fotheringhay, Oundle. **STEELE'S CLASS.**—1, W. A. Taylor. 2, C. Wright (Spanish). 3, H. Yardley. 4, S. Deacon (Aylesbury). 5, J. Smith (Grey Dorkings).

PIGEONS.—1 and 2, H. Yardley. 3, J. J. Sharp, Broughton, Kettering.

The Judges were Mr. Edward Hewitt, of Sparkbrook, Birmingham; and Mr. Tatham, of Kingshorpe, near Northampton.

AYLESBURY POULTRY SHOW.

This Show was held in a building as well suited for the purpose as could be desired, there being an abundance of light and plenty of ventilation and space. The competition throughout was very good, but in the *Aylesbury Ducks* and *Geese* unprecedented, as may be gathered from these facts:—The two rivals in these classes were determined to secure success if possible to their respective yards, and it is almost needless to state they were Mrs. Mary Seamons and Mr. John Fowler, both of Aylesbury. Such pens as they exhibited are in truth wonders. Mr. Fowler's first-prize *Geese* weighed 19 lbs. 4 ozs. the pair; Mrs. Seamons' second-prize 45 lbs. 11 ozs., and the same lady's third-prize 4 lbs. 13 ozs.; whilst 17 lbs. 8 ozs. nett the pair, with many others closely approaching to that weight, had to be satisfied with being highly commended. Both first and second-prize *Aylesbury Ducks* were 16 lbs. 12 ozs. per couple. Strange to say, there was not the slightest difference in weight, and Mrs. Seamons' birds, from being the best in feather, took precedence. Never were two such faultless couples placed in opposition; they were a show in themselves. Many extra couples almost as heavy were also exhibited. Fine weather and a very large attendance added much to the success of this year's Show.

DORKINGS (Any variety).—1 and Cup, L. Patton, Hillmore, Taunton. 2 and 3, C. Parle, Great Edder. 4, J. Longland, Grandon. 5, J. L. Lowndes, Hartwell. 6, T. W. Tapping, Hartwell. **BANTAMS (Any variety).**—1 and Cup, Lady Gwydyr, Stoke Park, Ipswich. 2, J. K. Fowler, Aylesbury. 3, Mrs. Astley, Chequers Court, Spanish. 4 and Cup, F. James, Fockham Rye. 5, W. R. Bull, Newport Pagnell. 6, Mrs. Allsopp, Hindlip Hall, Worcester. 7, W. A. Taylor, Stratford, Addington Park, Maidstone. 8, F. R. C. Nichols, Camberwell, H. Ebdon, Göttslock. **COCHINS.**—1 and Cup, Lady Gwydyr. 2, C. Sidgwick, Ryddesden Hall, Kettering. 3 and 4, W. H. Evans, Frington, Birmingham. 5, J. K. Fowler. **BIRDS.**—1 and Cup, C. Sidgwick. 2 and 3, J. K. Fowler. 4, Lord Chesham, Latimers. **GAME.**—*Black-breasted and other Reds.*—1 and Cup, J. Lamug, Cowburn, Spalding. 2 and 3, S. Matthews, Stowmarket. 4, J. Lamug, Gloucester. *Any other Colour.*—1 and 2, D. Matthews, Stowmarket. 3, J. Lamug. **FRENCH (Any variety).**—1 and Cup, J. J. Malden, Biddlewade (Creve-Geur). 2, Hon. H. W. Fitzwilliam, M.P., Wentworth Woodhouse (La Fochelle). 3, W. A. Taylor. 4, W. A. Taylor. 5, W. R. Bull. 6, W. R. Bull. 7, J. K. Fowler. 8, J. K. Fowler. 9, J. K. Fowler. 10, J. K. Fowler. 11, J. K. Fowler. 12, J. K. Fowler. 13, J. K. Fowler. 14, J. K. Fowler. 15, J. K. Fowler. 16, J. K. Fowler. 17, J. K. Fowler. 18, J. K. Fowler. 19, J. K. Fowler. 20, J. K. Fowler. 21, J. K. Fowler. 22, J. K. Fowler. 23, J. K. Fowler. 24, J. K. Fowler. 25, J. K. Fowler. 26, J. K. Fowler. 27, J. K. Fowler. 28, J. K. Fowler. 29, J. K. Fowler. 30, J. K. Fowler. 31, J. K. Fowler. 32, J. K. Fowler. 33, J. K. Fowler. 34, J. K. Fowler. 35, J. K. Fowler. 36, J. K. Fowler. 37, J. K. Fowler. 38, J. K. Fowler. 39, J. K. Fowler. 40, J. K. Fowler. 41, J. K. Fowler. 42, J. K. Fowler. 43, J. K. Fowler. 44, J. K. Fowler. 45, J. K. Fowler. 46, J. K. Fowler. 47, J. K. Fowler. 48, J. K. Fowler. 49, J. K. Fowler. 50, J. K. Fowler. 51, J. K. Fowler. 52, J. K. Fowler. 53, J. K. Fowler. 54, J. K. Fowler. 55, J. K. Fowler. 56, J. K. Fowler. 57, J. K. Fowler. 58, J. K. Fowler. 59, J. K. Fowler. 60, J. K. Fowler. 61, J. K. Fowler. 62, J. K. Fowler. 63, J. K. Fowler. 64, J. K. Fowler. 65, J. K. Fowler. 66, J. K. Fowler. 67, J. K. Fowler. 68, J. K. Fowler. 69, J. K. Fowler. 70, J. K. Fowler. 71, J. K. Fowler. 72, J. K. Fowler. 73, J. K. Fowler. 74, J. K. Fowler. 75, J. K. Fowler. 76, J. K. Fowler. 77, J. K. Fowler. 78, J. K. Fowler. 79, J. K. Fowler. 80, J. K. Fowler. 81, J. K. Fowler. 82, J. K. Fowler. 83, J. K. Fowler. 84, J. K. Fowler. 85, J. K. Fowler. 86, J. K. Fowler. 87, J. K. Fowler. 88, J. K. Fowler. 89, J. K. Fowler. 90, J. K. Fowler. 91, J. K. Fowler. 92, J. K. Fowler. 93, J. K. Fowler. 94, J. K. Fowler. 95, J. K. Fowler. 96, J. K. Fowler. 97, J. K. Fowler. 98, J. K. Fowler. 99, J. K. Fowler. 100, J. K. Fowler. 101, J. K. Fowler. 102, J. K. Fowler. 103, J. K. Fowler. 104, J. K. Fowler. 105, J. K. Fowler. 106, J. K. Fowler. 107, J. K. Fowler. 108, J. K. Fowler. 109, J. K. Fowler. 110, J. K. Fowler. 111, J. K. Fowler. 112, J. K. Fowler. 113, J. K. Fowler. 114, J. K. Fowler. 115, J. K. Fowler. 116, J. K. Fowler. 117, J. K. Fowler. 118, J. K. Fowler. 119, J. K. Fowler. 120, J. K. Fowler. 121, J. K. Fowler. 122, J. K. Fowler. 123, J. K. Fowler. 124, J. K. Fowler. 125, J. K. Fowler. 126, J. K. Fowler. 127, J. K. Fowler. 128, J. K. Fowler. 129, J. K. Fowler. 130, J. K. Fowler. 131, J. K. Fowler. 132, J. K. Fowler. 133, J. K. Fowler. 134, J. K. Fowler. 135, J. K. Fowler. 136, J. K. Fowler. 137, J. K. Fowler. 138, J. K. Fowler. 139, J. K. Fowler. 140, J. K. Fowler. 141, J. K. Fowler. 142, J. K. Fowler. 143, J. K. Fowler. 144, J. K. Fowler. 145, J. K. Fowler. 146, J. K. Fowler. 147, J. K. Fowler. 148, J. K. Fowler. 149, J. K. Fowler. 150, J. K. Fowler. 151, J. K. Fowler. 152, J. K. Fowler. 153, J. K. Fowler. 154, J. K. Fowler. 155, J. K. Fowler. 156, J. K. Fowler. 157, J. K. Fowler. 158, J. K. Fowler. 159, J. K. Fowler. 160, J. K. Fowler. 161, J. K. Fowler. 162, J. K. Fowler. 163, J. K. Fowler. 164, J. K. Fowler. 165, J. K. Fowler. 166, J. K. Fowler. 167, J. K. Fowler. 168, J. K. Fowler. 169, J. K. Fowler. 170, J. K. Fowler. 171, J. K. Fowler. 172, J. K. Fowler. 173, J. K. Fowler. 174, J. K. Fowler. 175, J. K. Fowler. 176, J. K. Fowler. 177, J. K. Fowler. 178, J. K. Fowler. 179, J. K. Fowler. 180, J. K. Fowler. 181, J. K. Fowler. 182, J. K. Fowler. 183, J. K. Fowler. 184, J. K. Fowler. 185, J. K. Fowler. 186, J. K. Fowler. 187, J. K. Fowler. 188, J. K. Fowler. 189, J. K. Fowler. 190, J. K. Fowler. 191, J. K. Fowler. 192, J. K. Fowler. 193, J. K. Fowler. 194, J. K. Fowler. 195, J. K. Fowler. 196, J. K. Fowler. 197, J. K. Fowler. 198, J. K. Fowler. 199, J. K. Fowler. 200, J. K. Fowler. 201, J. K. Fowler. 202, J. K. Fowler. 203, J. K. Fowler. 204, J. K. Fowler. 205, J. K. Fowler. 206, J. K. Fowler. 207, J. K. Fowler. 208, J. K. Fowler. 209, J. K. Fowler. 210, J. K. Fowler. 211, J. K. Fowler. 212, J. K. Fowler. 213, J. K. Fowler. 214, J. K. Fowler. 215, J. K. Fowler. 216, J. K. Fowler. 217, J. K. Fowler. 218, J. K. Fowler. 219, J. K. Fowler. 220, J. K. Fowler. 221, J. K. Fowler. 222, J. K. Fowler. 223, J. K. Fowler. 224, J. K. Fowler. 225, J. K. Fowler. 226, J. K. Fowler. 227, J. K. Fowler. 228, J. K. Fowler. 229, J. K. Fowler. 230, J. K. Fowler. 231, J. K. Fowler. 232, J. K. Fowler. 233, J. K. Fowler. 234, J. K. Fowler. 235, J. K. Fowler. 236, J. K. Fowler. 237, J. K. Fowler. 238, J. K. Fowler. 239, J. K. Fowler. 240, J. K. Fowler. 241, J. K. Fowler. 242, J. K. Fowler. 243, J. K. Fowler. 244, J. K. Fowler. 245, J. K. Fowler. 246, J. K. Fowler. 247, J. K. Fowler. 248, J. K. Fowler. 249, J. K. Fowler. 250, J. K. Fowler. 251, J. K. Fowler. 252, J. K. Fowler. 253, J. K. Fowler. 254, J. K. Fowler. 255, J. K. Fowler. 256, J. K. Fowler. 257, J. K. Fowler. 258, J. K. Fowler. 259, J. K. Fowler. 260, J. K. Fowler. 261, J. K. Fowler. 262, J. K. Fowler. 263, J. K. Fowler. 264, J. K. Fowler. 265, J. K. Fowler. 266, J. K. Fowler. 267, J. K. Fowler. 268, J. K. Fowler. 269, J. K. Fowler. 270, J. K. Fowler. 271, J. K. Fowler. 272, J. K. Fowler. 273, J. K. Fowler. 274, J. K. Fowler. 275, J. K. Fowler. 276, J. K. Fowler. 277, J. K. Fowler. 278, J. K. Fowler. 279, J. K. Fowler. 280, J. K. Fowler. 281, J. K. Fowler. 282, J. K. Fowler. 283, J. K. Fowler. 284, J. K. Fowler. 285, J. K. Fowler. 286, J. K. Fowler. 287, J. K. Fowler. 288, J. K. Fowler. 289, J. K. Fowler. 290, J. K. Fowler. 291, J. K. Fowler. 292, J. K. Fowler. 293, J. K. Fowler. 294, J. K. Fowler. 295, J. K. Fowler. 296, J. K. Fowler. 297, J. K. Fowler. 298, J. K. Fowler. 299, J. K. Fowler. 300, J. K. Fowler. 301, J. K. Fowler. 302, J. K. Fowler. 303, J. K. Fowler. 304, J. K. Fowler. 305, J. K. Fowler. 306, J. K. Fowler. 307, J. K. Fowler. 308, J. K. Fowler. 309, J. K. Fowler. 310, J. K. Fowler. 311, J. K. Fowler. 312, J. K. Fowler. 313, J. K. Fowler. 314, J. K. Fowler. 315, J. K. Fowler. 316, J. K. Fowler. 317, J. K. Fowler. 318, J. K. Fowler. 319, J. K. Fowler. 320, J. K. Fowler. 321, J. K. Fowler. 322, J. K. Fowler. 323, J. K. Fowler. 324, J. K. Fowler. 325, J. K. Fowler. 326, J. K. Fowler. 327, J. K. Fowler. 328, J. K. Fowler. 329, J. K. Fowler. 330, J. K. Fowler. 331, J. K. Fowler. 332, J. K. Fowler. 333, J. K. Fowler. 334, J. K. Fowler. 335, J. K. Fowler. 336, J. K. Fowler. 337, J. K. Fowler. 338, J. K. Fowler. 339, J. K. Fowler. 340, J. K. Fowler. 341, J. K. Fowler. 342, J. K. Fowler. 343, J. K. Fowler. 344, J. K. Fowler. 345, J. K. Fowler. 346, J. K. Fowler. 347, J. K. Fowler. 348, J. K. Fowler. 349, J. K. Fowler. 350, J. K. Fowler. 351, J. K. Fowler. 352, J. K. Fowler. 353, J. K. Fowler. 354, J. K. Fowler. 355, J. K. Fowler. 356, J. K. Fowler. 357, J. K. Fowler. 358, J. K. Fowler. 359, J. K. Fowler. 360, J. K. Fowler. 361, J. K. Fowler. 362, J. K. Fowler. 363, J. K. Fowler. 364, J. K. Fowler. 365, J. K. Fowler. 366, J. K. Fowler. 367, J. K. Fowler. 368, J. K. Fowler. 369, J. K. Fowler. 370, J. K. Fowler. 371, J. K. Fowler. 372, J. K. Fowler. 373, J. K. Fowler. 374, J. K. Fowler. 375, J. K. Fowler. 376, J. K. Fowler. 377, J. K. Fowler. 378, J. K. Fowler. 379, J. K. Fowler. 380, J. K. Fowler. 381, J. K. Fowler. 382, J. K. Fowler. 383, J. K. Fowler. 384, J. K. Fowler. 385, J. K. Fowler. 386, J. K. Fowler. 387, J. K. Fowler. 388, J. K. Fowler. 389, J. K. Fowler. 390, J. K. Fowler. 391, J. K. Fowler. 392, J. K. Fowler. 393, J. K. Fowler. 394, J. K. Fowler. 395, J. K. Fowler. 396, J. K. Fowler. 397, J. K. Fowler. 398, J. K. Fowler. 399, J. K. Fowler. 400, J. K. Fowler. 401, J. K. Fowler. 402, J. K. Fowler. 403, J. K. Fowler. 404, J. K. Fowler. 405, J. K. Fowler. 406, J. K. Fowler. 407, J. K. Fowler. 408, J. K. Fowler. 409, J. K. Fowler. 410, J. K. Fowler. 411, J. K. Fowler. 412, J. K. Fowler. 413, J. K. Fowler. 414, J. K. Fowler. 415, J. K. Fowler. 416, J. K. Fowler. 417, J. K. Fowler. 418, J. K. Fowler. 419, J. K. Fowler. 420, J. K. Fowler. 421, J. K. Fowler. 422, J. K. Fowler. 423, J. K. Fowler. 424, J. K. Fowler. 425, J. K. Fowler. 426, J. K. Fowler. 427, J. K. Fowler. 428, J. K. Fowler. 429, J. K. Fowler. 430, J. K. Fowler. 431, J. K. Fowler. 432, J. K. Fowler. 433, J. K. Fowler. 434, J. K. Fowler. 435, J. K. Fowler. 436, J. K. Fowler. 437, J. K. Fowler. 438, J. K. Fowler. 439, J. K. Fowler. 440, J. K. Fowler. 441, J. K. Fowler. 442, J. K. Fowler. 443, J. K. Fowler. 444, J. K. Fowler. 445, J. K. Fowler. 446, J. K. Fowler. 447, J. K. Fowler. 448, J. K. Fowler. 449, J. K. Fowler. 450, J. K. Fowler. 451, J. K. Fowler. 452, J. K. Fowler. 453, J. K. Fowler. 454, J. K. Fowler. 455, J. K. Fowler. 456, J. K. Fowler. 457, J. K. Fowler. 458, J. K. Fowler. 459, J. K. Fowler. 460, J. K. Fowler. 461, J. K. Fowler. 462, J. K. Fowler. 463, J. K. Fowler. 464, J. K. Fowler. 465, J. K. Fowler. 466, J. K. Fowler. 467, J. K. Fowler. 468, J. K. Fowler. 469, J. K. Fowler. 470, J. K. Fowler. 471, J. K. Fowler. 472, J. K. Fowler. 473, J. K. Fowler. 474, J. K. Fowler. 475, J. K. Fowler. 476, J. K. Fowler. 477, J. K. Fowler. 478, J. K. Fowler. 479, J. K. Fowler. 480, J. K. Fowler. 481, J. K. Fowler. 482, J. K. Fowler. 483, J. K. Fowler. 484, J. K. Fowler. 485, J. K. Fowler. 486, J. K. Fowler. 487, J. K. Fowler. 488, J. K. Fowler. 489, J. K. Fowler. 490, J. K. Fowler. 491, J. K. Fowler. 492, J. K. Fowler. 493, J. K. Fowler. 494, J. K. Fowler. 495, J. K. Fowler. 496, J. K. Fowler. 497, J. K. Fowler. 498, J. K. Fowler. 499, J. K. Fowler. 500, J. K. Fowler. 501, J. K. Fowler. 502, J. K. Fowler. 503, J. K. Fowler. 504, J. K. Fowler. 505, J. K. Fowler. 506, J. K. Fowler. 507, J. K. Fowler. 508, J. K. Fowler. 509, J. K. Fowler. 510, J. K. Fowler. 511, J. K. Fowler. 512, J. K. Fowler. 513, J. K. Fowler. 514, J. K. Fowler. 515, J. K. Fowler. 516, J. K. Fowler. 517, J. K. Fowler. 518, J. K. Fowler. 519, J. K. Fowler. 520, J. K. Fowler. 521, J. K. Fowler. 522, J. K. Fowler. 523, J. K. Fowler. 524, J. K. Fowler. 525, J. K. Fowler. 526, J. K. Fowler. 527, J. K. Fowler. 528, J. K. Fowler. 529, J. K. Fowler. 530, J. K. Fowler. 531, J. K. Fowler. 532, J. K. Fowler. 533, J. K. Fowler. 534, J. K. Fowler. 535, J. K. Fowler. 536, J. K. Fowler. 537, J. K. Fowler. 538, J. K. Fowler. 539, J. K. Fowler. 540, J. K. Fowler. 541, J. K. Fowler. 542, J. K. Fowler. 543, J. K. Fowler. 544, J. K. Fowler. 545, J. K. Fowler. 546, J. K. Fowler. 547, J. K. Fowler. 548, J. K. Fowler. 549, J. K. Fowler. 550, J. K. Fowler. 551, J. K. Fowler. 552, J. K. Fowler. 553, J. K. Fowler. 554, J. K. Fowler. 555, J. K. Fowler. 556, J. K. Fowler. 557, J. K. Fowler. 558, J. K. Fowler. 559, J. K. Fowler. 560, J. K. Fowler. 561, J. K. Fowler. 562, J. K. Fowler. 563, J. K. Fowler. 564, J. K. Fowler. 565, J. K. Fowler. 566, J. K. Fowler. 567, J. K. Fowler. 568, J. K. Fowler. 569, J. K. Fowler. 570, J. K. Fowler. 571, J. K. Fowler. 572, J. K. Fowler. 573, J. K. Fowler. 574, J. K. Fowler. 575, J. K. Fowler. 576, J. K. Fowler. 577, J. K. Fowler. 578, J. K. Fowler. 579, J. K. Fowler. 580, J. K. Fowler. 581, J. K. Fowler. 582, J. K. Fowler. 583, J. K. Fowler. 584, J. K. Fowler. 585, J. K. Fowler. 586, J. K. Fowler. 587, J. K. Fowler. 588, J. K. Fowler. 589, J. K. Fowler. 590, J. K. Fowler. 591, J. K. Fowler. 592, J. K. Fowler. 593, J. K. Fowler. 594, J. K. Fowler. 595, J. K. Fowler. 596, J. K. Fowler. 597, J. K. Fowler. 598, J. K. Fowler. 599, J. K. Fowler. 600, J. K. Fowler. 601, J. K. Fowler. 602, J. K. Fowler. 603, J. K. Fowler. 604, J. K. Fowler. 605, J. K. Fowler. 606, J. K. Fowler. 607, J. K. Fowler. 608, J. K. Fowler. 609, J. K. Fowler. 610, J. K. Fowler. 611, J. K. Fowler. 612, J. K. Fowler. 613, J. K. Fowler. 614, J. K. Fowler. 615, J. K. Fowler. 616, J. K. Fowler. 617, J. K. Fowler. 618, J. K. Fowler. 619, J. K. Fowler. 620, J. K. Fowler. 621, J. K. Fowler. 622, J. K. Fowler. 623, J. K. Fowler. 624, J. K. Fowler. 625, J. K. Fowler. 626, J. K. Fowler. 627, J. K. Fowler. 628, J. K. Fowler. 629, J. K. Fowler. 630, J. K. Fowler. 631, J. K. Fowler. 632, J. K. Fowler. 633, J. K. Fowler. 634, J. K. Fowler. 635, J. K. Fowler. 636, J. K. Fowler. 637, J. K. Fowler. 638, J. K. Fowler. 639, J. K. Fowler. 640, J. K. Fowler. 641, J. K. Fowler. 642, J. K. Fowler. 643, J. K. Fowler. 644, J. K. Fowler. 645, J. K. Fowler. 646, J. K. Fowler. 647, J. K. Fowler. 648, J. K. Fowler. 649, J. K. Fowler. 650, J. K. Fowler. 651, J. K. Fowler. 652, J. K. Fowler. 653, J. K. Fowler. 654, J. K. Fowler. 655, J. K. Fowler. 656, J. K. Fowler. 657, J. K. Fowler. 658, J. K. Fowler. 659, J. K. Fowler. 660, J. K. Fowler. 661, J. K. Fowler. 662, J. K. Fowler. 663, J. K. Fowler. 664, J. K. Fowler. 665, J. K. Fowler. 666, J. K. Fowler. 667, J. K. Fowler. 668, J. K. Fowler. 669, J. K. Fowler. 670, J. K. Fowler. 671, J. K. Fowler. 672, J. K. Fowler. 673, J. K. Fowler. 674, J. K. Fowler. 675, J. K. Fowler. 676, J. K. Fowler. 677, J. K. Fowler. 678, J. K. Fowler. 679, J. K. Fowler. 680, J. K. Fowler. 681, J. K. Fowler. 682, J. K. Fowler. 683, J. K. Fowler. 684, J. K. Fowler. 685, J. K. Fowler. 686, J. K. Fowler. 687, J. K. Fowler. 688, J. K. Fowler. 689, J. K. Fowler. 690, J. K. Fowler. 691, J. K. Fowler. 692, J. K. Fowler. 693, J. K. Fowler. 694, J. K. Fowler. 695, J. K. Fowler. 696, J. K. Fowler. 697, J. K. Fowler. 698, J. K. Fowler. 699, J. K. Fowler. 700, J. K. Fowler. 701, J. K. Fowler. 702, J. K. Fowler. 703, J. K. Fowler. 704, J. K. Fowler. 705, J. K. Fowler. 706, J. K. Fowler. 707, J. K. Fowler. 708, J. K. Fowler. 709, J. K. Fowler. 710, J. K. Fowler. 711, J. K. Fowler. 712, J. K. Fowler. 713, J. K. Fowler. 714, J. K. Fowler. 715, J. K. Fowler. 716, J. K. Fowler. 717, J. K. Fowler. 718, J. K. Fowler. 719, J. K. Fowler. 720, J. K. Fowler. 721, J. K. Fowler. 722, J. K. Fowler. 723, J. K. Fowler. 724, J. K. Fowler. 725, J. K. Fowler. 726, J. K. Fowler. 727, J. K. Fowler. 728, J. K. Fowler. 729, J. K. Fowler. 730, J. K. Fowler. 731, J. K. Fowler. 732, J. K. Fowler. 733, J. K. Fowler. 734, J. K. Fowler. 735, J. K. Fowler. 736, J. K. Fowler. 737, J. K. Fowler. 738, J. K. Fowler. 739, J. K. Fowler. 740, J. K. Fowler. 741, J. K. Fowler. 742, J. K. Fowler. 743, J. K. Fowler. 744, J. K. Fowler. 745, J. K. Fowler. 746, J. K. Fowler. 747, J. K. Fowler. 748, J. K. Fowler. 749, J. K. Fowler. 750, J. K. Fowler. 751, J. K. Fowler. 752, J. K. Fowler. 753, J. K. Fowler. 754, J. K. Fowler. 755, J. K. Fowler. 756, J. K. Fowler. 757, J. K. Fowler. 758, J. K. Fowler. 759, J. K. Fowler. 760, J. K. Fowler. 761, J. K. Fowler. 762, J. K. Fowler. 763, J. K. Fowler. 764, J. K. Fowler. 765, J. K. Fowler. 766, J. K. Fowler. 767, J. K. Fowler. 768, J. K. Fowler. 769, J. K. Fowler. 770, J. K. Fowler. 771, J. K. Fowler. 772, J. K. Fowler. 773, J. K. Fowler. 774, J. K. Fowler. 775, J. K. Fowler. 776, J. K. Fowler. 777, J. K. Fowler. 778, J. K. Fowler. 779, J. K. Fowler. 780, J. K. Fowler. 781, J. K. Fowler. 782, J. K. Fowler. 783, J. K. Fowler. 784, J. K. Fowler. 785, J. K. Fowler. 786, J. K. Fowler. 787, J. K. Fowler. 788, J. K. Fowler. 789, J. K. Fowler. 790, J. K. Fowler. 791, J. K. Fowler. 792, J. K. Fowler. 793, J. K. Fowler. 794, J. K. Fowler. 795, J. K. Fowler. 796, J. K. Fowler. 797,

Ireland. c, T. Kingsley. (Special Class).—1 and Cap. Mrs. M. Smith, Haddenham. 2, J. Hedges, Aylesbury. 3, J. Funge, Long Marston. *hc*, Lord Chesham; J. Funge. c, Mrs. C. Oakley, Astrop, near Trinz. *Rouen*.—1 and Cap. Mrs. M. Seamons. 2, L. Patton. 3, F. Parlett, Great Baddow. *hc*, E. Leech; Mrs. M. Seamons; L. Patton; J. K. Fowler, c, J. L. Lowndes. *Any other Variety*.—1, S. Burn, Whitby, Yorkshire. 2, J. Saunders, Sainsbury, Devizes (Buenos Ayrens). 3, M. Leno (Carolina). *GEESSE* (Any variety).—1 and Cap. J. K. Fowler. 2 and 3, Mrs. M. Seamons, *hc*, E. Leech; J. Denchfield, Hurston; J. K. Fowler. c, W. Parrot, Ford. *TERKEYS* (Any variety).—1 and Cap. E. Leech. 2 and 3, Lord Chesham. *hc*, J. K. Fowler. c, Capt. Dauncey, High Wycombe. *PHEASANTS* (Any variety).—1, 2, and 3, J. K. Fowler. *hc*, M. Leno. *SELLING CLASS*.—1, 2, and 3, J. K. Fowler (Dark Brahma and Grey Geese), 3 and *hc*, Mrs. M. Seamons (Silky Fowler).

PIGEONS.—*Carriers* (Any variety).—1 and 2, H. Yardley, Birmingham. *Pouters* (Any variety).—1, H. Yardley. 2, J. K. Fowler. *Fantails* (Any variety).—1 and 2, H. Yardley. *Any other Variety*.—1, H. Yardley (White Owls). 2, Lady F. Bushby, (B'ne Runts). *hc*, H. Gurney, jun., Aylesbury; J. K. Fowler.

Mr. Edward Hewitt, Sparkbrook, near Birmingham, was the Judge.

(From a Correspondent.)

This was the twelfth Show in connection with the Royal Buckinghamshire Agricultural Association. The entries were very small, especially the Pigeons, in some classes there being only two entries for a similar number of prizes. The few entries were no doubt caused by the heavy entry fees—viz., 5s. per pen, and another 5s. for membership to the Association. This appears rather high for a chance of winning a ten-shilling prize. On referring to the catalogue I find no less than fourteen silver cups or pieces of plate, each forming the first prize for as many different classes. These were all given by patrons or friends, so that the Poultry Show must form a very profitable source of income to the Association; and I would suggest to the Committee that they should do away with the five-shilling membership, throw the competition open to all, and they would then get far more numerous entries.

The *Dorkings* stood first, and of these there were some very good birds. Those in the cup pen were in excellent feather and condition, but I fancied the cock had a wry tail. The second-prize birds were also good, but I should not like to say the third were this year's birds; if so, they must have been hatched very early on New-year's morning. The cup for *Brahmas* was won by a splendid pair of Dark, the second prize went to Light. *Spanish* were a capital lot, the best I have seen this year. The pullet in the cup pen was very forward for one of this year's birds. The second-prize cock was matched with an inferior pullet, and he also must have been hatched very early this year. I did not like the award of the third prize, there was a decidedly better pair amongst those which were only commended; and here, perhaps, I may remark that judges frequently give prizes to the best cock when it is offered for the best cock and hen, often entirely ignoring the latter. The cup pen of Buff *Cochins* were a wonderful pair of birds, beautiful in colour and feather, and excellently shown. The Partridge were also good, especially the first and second-prize pens. *Game* were hardly so good as might have been expected. Of *French* fowls there was a very fair entry, and some of the birds were very superior. Black *Crève-Coeurs* were first. A good pair of *Houdans* arrived too late for competition, or they would certainly have obtained a prize. *Hamburghs* were few and of no particular merit. As might be expected, the *Bantams* were a very poor class when we find, as we do here, the many different varieties of this very popular class all jumbled together. The first prize went to a good pen of *Sebrights*, and there was nothing else in the class worthy of notice.

Ducks were a splendid lot, the first and second prize *Aylesbury* Ducks being of exactly the same weight; but the first were in fair feather, and consequently won the cup. *Rouen* Ducks were likewise good, and there was an excellent drake in the cup pen. The *Geese* were very remarkable in size and weight, but heavy in moult. *Turkeys* were fair. The *Pheasants* were a very pretty class, and created much interest amongst the numerous visitors. The *Selling Class* was a failure; five entries—one pen empty, and three prizes. The *Pigeons* were a wretched entry as regards numbers. Mr. Yardley took all the first and most of the second prizes.

WELLINGTON (SALOP) POULTRY SHOW.

In again bringing before the neighborhood this Show as a candidate for public favour, the Committee wisely determined to make it entirely a show of poultry hatched in the present year, and most of our readers who happened to be present were well pleased at finding at Wellington some of the very best birds in the kingdom. There was not a single class that was not well represented, saving one, which, singularly enough, was that for the best *Game* cockerel. Here there was not a single entry. The *Game* fowls shown in pairs were, on the contrary, excellent. The *Hamburghs* of every kind were extraordinarily good, though a pen or two were disqualified on account of adult specimens being exhibited as chickens, evidently rather from a misunderstanding of the prize schedule than from willing imposition. The "Extra Variety" class was one of the best ever exhibited, and the largest in the Show; so good indeed was it, that every pen that remained after the two general premiums were awarded was highly commended. No prizes for *Pigeons* were offered, yet the Show was singularly well supported and attractive.

GAME.—*Black or Brown Red*.—1, J. Platt, Swanlow. 2, Duke of Sutherland, *hc*, G. Lind. *Any other Variety*.—1, J. Platt. 2, W. Dunning, Newport. *hc*, G. Lind. *DORKINGS*.—1, E. Shaw, Plas Wilnot, Oswestry. 2, Mrs. E. Williams, Henllys, Berriew. *hc*, J. Edwards, Epton; A. Darby, Stanley Hall, Bridgmont, SPANISH (Black).—1, R. Hulso, Wray Green, Cheshire. 2, E. Shaw. *HAMBURGHS*.—*Gold or Silver-splangled*.—1, Duke of Sutherland. 2, J. C. Smith,

Wellington. *hc*, C. Parsons, Wolverhampton; T. Hassall, Adderley, Market Drayton. *Gold or Silver pencilled*.—1 and 2, Duke of Sutherland. *ANY OTHER VARIETY*.—1, Duke of Sutherland (Black Hamburgs). 2, Mrs. E. Williams (Crève-Coeur). *hc*, H. Yardley (2); A. Darby (2); J. G. Pearson, Market Drayton; A. D. Payne, Shrewsbury. *DUCKS*.—1, J. Platt. 2, T. Radcliffe, Newport. c, St. J. C. Charlton (2). *GEESSE*.—1, E. Shaw. 2, J. Edwards. c, T. W. Jones, Wellington. *TERKEYS*.—1 and 2, T. W. Jones.

The Judge was Mr. Edward Hewitt, of Sparkbrook, Birmingham.

NATIONAL PERISTERONIC SOCIETY.

This Society, which numbers amongst its members some of the leading breeders of Great Britain, held its first meeting for the season at the Freemason's Tavern, Great Queen Street, London, on the 20th inst., and if we are to judge by the quality and quantity of young birds shown, this has been a very successful season. As this is not a competitive Show, we were spared the complaints of disappointed exhibitors; but were glad to learn, on the other hand, there is every prospect of the forthcoming Crystal Palace Show, in the Cattle Show week, being second to none, as in one corner of the room four of its members promised five five-guinea pieces of plate, and no doubt others will follow their example. Amongst the birds shown were a splendid lot of young *Carriers* from Messrs. Ord and Hedley, with that stately carriage and prominent eye that at once stamps this species as the king of Pigeons. The latter gentleman also exhibited a pair of old birds, which, as a visitor said, would, if publicly exhibited, be a show in themselves. The Honorary Secretary, Mr. P. H. Jones, showed a good pen of *Pouters*, also some of the best *Trumpeters* since their parents were shown here three years ago. He also contributed some other beautiful Toys, consisting of *Turbits*, *Nuns*, *Maggies*, *English Owls*, and *Barks*, aided in the last species by half a dozen from Mr. Hedley. Messrs. Else and Betty showed some good *Dragoons*, a paper respecting which will be read by Mr. Tegetmeier at the next meeting on the 4th of October. This gentleman sent a very pretty and good lot of *Antwerps* and *Carriers*. Last, but not least, were two pens of *Almonds* and *Kites* from Messrs. Jayne and Ford, which we have no doubt will be heard of again.

WHITBY CANARY SHOW.

My wife was not quite ready, and I was waiting at the door. "No hurry, sir, no hurry. I can do it in six minutes, and it wants ten minutes yet, ten minutes good. Plenty of time, sir, pl-e-n-t-y of time." That's what cabby said. "William, where is the key of the black portmanteau?" That's what my wife said. No hurry, indeed! The position was critical. Given ten minutes to reach the station, and a willing cabby open to back himself for a small amount to do it in six. Required to find the key of the black portmanteau; to unlock it (itself a feat only to be attempted when the lock is in a good humor); to stuff it with articles too large to go in it, and more of them than it would hold, even if they would; to go through the horrors of locking it, and getting the key out of the keyhole without unlocking it again; to decide whether somebody's back hair was all right; to do this and catch the train all in four minutes without losing your temper, that's the problem. Postulates—Let it be granted that the key of the black portmanteau can never be found when wanted, and that two bodies cannot occupy the same space. Axiom—when a thing has happened frequently before, you needn't be surprised at its happening again. But we just did it. Cabby had orders to force the pace, which he did, and, making a brilliant "finish," he beat time with a little in hand.

We went by the night train, and though it was full moon (a remarkable coincidence, but I only mention it as a fact), there was not a great deal to be seen. Rosebery Topping and the Clevelanders were sleeping with grey nightcaps on. Night was turned into day as we sped through the ironstone district about Glaisdale. The tall blast furnaces were some of them belching out flames, casting a lurid glare over the surrounding woods; others discharging streams of liquid fire, while demons and sprites flitted about in all directions feeding huge fires, cramming the capacious maw of some immense furnace, or trotting off to "tip" a cauldron of molten slag over some mountain of an embankment where thousands of tons had gone before, and down whose sides it crept with stealthy step, a river of fire.

Arrived at Whitby, we were most kindly received by the Honorary Secretary, James Wilkinson, Esq., and Mrs. Wilkinson, and one more strong link was welded to the chain which my connection with the Canary and "our Journal" has forged about me. As I was not required at the Show till about eleven o'clock we had a drive, and "did" the place. It was a very rapid "do," and I could only get a passing glance, but my recollection of Whitby is going up a very steep street in a carriage with two ladies in front, who seemed every now and then in imminent danger of falling forwards into my lap; a sweep round a fine terrace on the cliff; then a winding descent to the quay; am-

phibious creatures in oilskins salting barrels of herrings; across a short drawbridge at the entrance to the harbour; along a narrow street by the river side where, fortunately, we met no other conveyance, or else one or the other must have been compelled to back out; up a steep ascent almost on my back, and we were at the ruins of the old abbey on the brow of the hill, forming the south side of the valley of the Esk. A hurried walk round the churchyard which stands on the verge of the cliff, a peep over the edge of the sea, the piers, and the town at my feet, and we commenced our descent, the horse foreshortened till his ears seemed growing in the neighbourhood of his tail. To prevent accident I shored myself up with my umbrella, and got down with no further inconvenience than a strong tendency to slide off my seat. A zigzag crawl up the other side landed me at the door of the Congress Hall, where the Show was held, and as there were a few minutes to spare while the finishing touches were being put to the arrangement of the birds, I occupied the time in inspecting the horticultural department.

The show of plants was not large, I mean not very large, but there were some lovely specimens, the arrangement being on the whole very good. The centre stage appropriated to this branch had a very imposing effect. There were excellent collections of stove and greenhouse plants, ornamental-foliaged plants, small Conifers, Lilliums, hardy herbaceous specimen plants in flower or fruit well-fruited Vines in pots, Tricolored Geraniums, Ferns, and a host of other things. On either side was a long table, one for cut flowers, and the other for fruit. Dahlias, Asters, French and African Marigolds (real Jonques), Verbenas, Gladioli, &c., were excellent. A table placed transversely at the end of the Hall was filled with choice bouquets for the hand, ball-room or wedding, while the fruit table was decorated with groups of flowers and fruit in ornamental stands for the dining table. The collection of fruit was splendid, comprising White, Black, and Frontignan Grapes, in single bunches and trays of three; Pines, Melons, Peaches, Nectarines, Apricots, Plums, in variety; Apples and Pears without end; Currants as large as small Grapes; Gooseberries, and trays of collections. Looking at the fruit I sympathised with poor Eve. The vegetables were first-class, and on a gigantic scale—Cucumbers 30 inches long, and well grown; Celery enormous; Onions, Carrots, Parsnips, Turnips, in perfection; Potatoes, of all shapes; Cabbages, by the cubic yard, I was going to say; Peas, capital; ditto Beans, and Vegetable Marrows in all stages. The cottagers' groups, too, were very creditable, and in some cases would not have disgraced a gentleman's gardener.

The exhibition of Canaries has an interest which attaches to no other show, inasmuch as it is the first of the season, and exhibitors and fanciers in general look to Whitby to mark the advent of youngsters destined to play a prominent part in the Canary world. Last year this was notably the case, but on this occasion, owing to the late moult, there were not so many new stars discovered. Many of the best of our All-England men sent entries, and before I have a little chat with them allow me to shake hands with them all round. Mr. Moore (old warrior), and your other half, Mr. Wynn; Mr. Bexson (I've never seen you, and I often wonder what you're like?); Mr. Irons (the crested hen has come out very fresh again); Mr. Hawman (what got the Lizard cock? it wasn't there); Mr. Bulmer (she's a bonny little hen, rather small); Mr. Simpson, Mr. J. N. Harrison, Mr. Barwell, Mr. Adams, Mr. Burton, Mr. Wales, Mr. Fairclough, everybody—how do you do? I congratulate you on the opening of the season, hope you have all had good luck. Was it a good show? Very good indeed, and the arrangements not to be excelled. The Jonques were fair birds, but there are better to come. Irons won easily. Simpson has got into a good seam; his first-prize mealy bird will give you all some trouble this season, if he is only brought out in condition to the end. His six Jonques in Class 19 were six very nice level birds. Whitty will hold its own this year. The marked classes contained some excellent birds. Moore's even-marked Yellow is bad to beat, but the colour is not so pure a Jonque as I should like. Adams's two, 32 and 33, were fine lusty birds, of good size and capital quality. I had some difficulty in coming to a decision in the Even-marked Meales. Bexson's bird, 41, was the nearest to the type, but second and third were nice birds also. In the Ticked classes the first birds were good, and very cheap at the catalogue price—plenty of quality. With the exception of Irons's Buff Hen I cannot praise the Crests—there was too much "copy" in some of them. The crest is imported from other varieties, I admit, but breed out the distinctive features of those varieties a little more

before calling them "Norwich." You know as well as I do that a Norwich bird is not a foot long, nor does it stand nearly as upright as a Belgian. Belgians were very backward in condition. No 76 made one demonstration of what he was capable of doing, and then rolled himself into a ball, the picture of misery. Bulmer's Hen, No. 78, and Bexson's 81 were most forward in the Buff class, and performed best. The Yorkshire were as usual mixed up with Norwich birds, some of which would not have disgraced Class 2. The winning birds were lengthy and asymmetrical. Irons had it all his own way in Cinnamons, especially in the Buffs, Bexson not being in such form as last year, and Moore not making any decided mark. The Lizards were certainly not the best which will be sent out this year; but 117 (James Taylor) was a bird above the average, and Mr. Harrison had a useful one in each class. Greens were poor excepting the first, which was well through, and of good size and colour. Atkinson generally hunts up one or two good Greens. 129, Mark Burton, will see a better day. Judging the Mules resolved itself into a mere question of condition, none being through the moult. The district prizes were well contested, Mr. Simpson and Mrs. J. Wilkinson exhibiting birds of superior quality.

Another month will find us in the middle of the show season, at a time when birds look their best. In this district, Scarborough, North Ormesby, Middlesbrough, Darlington, Thirsk, Stockton, Stokesley, Newcastle, and other shows follow in quick succession. They are all under the management of enthusiastic fanciers, and deserving of strong support. At most of them I shall if all be well be present, possibly at all, and hope I shall see large entries of first-class birds.—W. A. BLAKSTON.

SWARMING.

In my remarks on swarming, in page 51 of "our Journal," I stated that I had never seen an old queen, that was prevented by unfavourable weather from going off with a swarm, destroy her own royal offspring in the cells in which they were maturing. Whilst doing so I had no intention of affirming that such an occurrence had not been observed by others. Mr. Taylor, in his manual on bee-keeping, when speaking of the issue of a swarm being prevented by weather, remarks, "The reigning sovereign will avail herself of this compulsory detention in severally destroying the young princesses as they are matured. An old queen is permitted by the bees to do this, but it is otherwise with a young one till a later stage." In this account of the matter other authorities agree, but I am not satisfied with the grounds on which their conclusions are founded. Huber, in one of his experiments, placed three royal cells in a hive containing a fertile queen, which were immediately pounced upon and pierced by the jealous sovereign. In another experiment immediately after the departure of a first swarm he found seven royal cells "close at the top, but open at the side, and quite empty."

Now, it was natural to conclude that these royal cells had been destroyed by the old queen, but perfect evidence of the fact is wanting. They might have been destroyed by a young queen which had escaped from her cell. That young queen might have gone off with the swarm, or fallen a sacrifice after her work of destruction in a mortal struggle with her own mother. It does not appear that the old queen was seen to destroy the royal cells. She might or she might not have done so; and this is what I would like to know, Whether any apiarian has had indubitable evidence of the queen, through swarming being delayed, deliberately setting to work to destroy the royal cells of her maturing offspring? That a queen introduced to a hive containing royal cells will destroy them, or that royal cells introduced into her hive will be torn open by her, is sufficiently proved by the experiment of Huber first referred to, and I can also imagine circumstances in which she would destroy cells tenanted by herself. For example, if she were removed a couple of days from her hive, and again restored to her dwelling, the destruction of royal cells might take place. This was inferentially proved by me in the course of last summer. On July 23rd a Woodbury box threw a large top swarm. The swarm was located in a common straw hive for thirty hours, and placed at some distance from the parent stock. Then about sunset the bees were all shaken out on to the ground, and made once more to re-enter their hive. As soon as settled the central hole of the parent stock was opened and the skep containing the swarm placed over it. I argued that the queen would probably remain in the skep for a day or two before descending to the parent stock, and that if she did she would

be unprepared to find royal cells, and in consequence destroy them. This probably happened, for no further swarming took place, but what was of most consequence was the fact that in the course of a month about 40 lbs. of beautiful honey were collected in the skep, there being only some two dozen cells with brood in them in the central comb. Had the skep with swarm not been converted into a super, it would most likely have been found to contain less than a third of the amount yielded in this way.—R. S.

THE NEW METHODS OF CONTROLLING THE FERTILISATION OF THE QUEEN BEE.

As several articles have appeared in your Journal upon the subject of controlling the fertilisation of the queen bee, I will add my testimony to that which has already been given in your pages. Early in June I had three young Italian queens (all hatched at the same time) at the head of three hives. One of these was left at liberty from the first, and was duly impregnated; the second was imprisoned with a number of drones for two days, as recommended by Mrs. Tupper; but as neither the queen nor drones afforded positive or negative proof of fertilisation having been effected, I allowed the queen to descend into the hive and follow her own natural instinct. She soon availed herself of her liberty, and proved a very fine and fertile queen. The third queen was confined for four or five days, but with like results, and when set at liberty took flight with difficulty, and never returned. The Kähler process has in like manner proved unsatisfactory. Some queens so treated have turned out drone-breeders, and some have been lost. Only one out of several secured a genuine impregnation, and she was nearly a month old before she began to lay.—J. E. B.

SINGULAR CASE OF ROBBING.

A CORRESPONDENT of an American paper says:—"I had a curious case of robbing last season. Two swarms of about equal strength commenced robbing each other; I tried my usual remedy, effectual in nearly every instance, which is a small rag saturated with camphor or spirits of turpentine placed on each side of the entrance, but it had no effect. I then carried one swarm into the cellar at night, and kept it there three days, and on setting them out they went at it again. I then set one swarm in the cellar three days, then set it out, and carried the other in for three days; and on setting them out they went at their old game. I then exchanged the stands, but it had no effect. There was no quarrelling between the swarms, so I let them work, and examined them every evening, and if one swarm had more than their share of honey I exchanged combs, and so kept them all right; but both swarms thought they were doing an extra large business, and consequently went to breeding very rapidly, more so than any other swarm I had. But they consumed a large quantity of honey, and gathered apparently double the quantity of pollen that any other swarm in my yard did during the same time. They kept up their practice until they commenced gathering honey abundantly, and then gradually ceased robbing altogether. That is the first case of the kind I ever knew.—E. G."

OUR LETTER BOX.

KEEPING POULTRY IN A CONFINED SPACE (M. W.).—The space is a small one, but with the arrangements you make you may easily keep two birds in health. In the way of green food, we advise you to give it every day instead of every alternate day, and to omit the cabbage; substitute seeds of growing grass, cut with plenty of earth. The fowls will tear them to pieces, eat the grass, and find all sorts of food and medicine in the fresh mould. Let them have their liberty every Sunday—it is better than nothing. You can buy such seeds as you require of the men who sell turves for Larks, and groundsel for singing birds.

POINTS OF CREVE-CŒURS.—SELECTING EGGS TO PRODUCE COCK OR HEN CHICKENS (E. E. F.).—If we go to the strict requirements of the breed, we should tell you the comb should present nearly the appearance of a cloven heart "Cœur Creve." In some birds it is early developed; in others it is very late; but the older the bird the larger the comb will be. The same may be said of the pullets. Two birds of the same age will show, one a bright red comb, the other no appearance of one; it merely proves that one is more forward than the other. They should be top-knotted and bearded, have short legs and square bodies. The legs should be black. The top-knots should be black, but as the pullets become hens white feathers appear in them, and in old birds they are nearly white. It is no proof of degeneracy, but, if possible, it should be avoided in show birds. We have tried the egg question by ourselves, and with the "learned" in such matters. We always failed. It is said the great success of "Francis Moore, Physician," with his "Vox Stellarum," or "Loyal Almanack," arose from the fact that when once he was walking up and down the room in a brown study, and his clerks were compiling the Almanack

for the following year, the subordinate who had charge of the month of June, asked him every time he passed, "Weather, sir, for the 3rd of June." Francis Moore bore it as long as he could. He showed his temper, it took no effect, and as he passed the desk he heard for the two hundred and eighty-first time, "Weather, sir, for the 3rd of June." We object to print the first part of the speech, but the end was, "— you, sir, frost and snow." It did freeze, and there was snow on that day. He was a made man. A chance made him, and the same may be said of the fortunate person who warranted thirteen eggs to produce twelve pullets and a cock. Fortune favours the bold. Ask him to try again. A friend of ours by no means distinguished as a shot, went as an amateur to a rifle corps target, and on being asked to take a shot, made a careless bull's eye at 600 yards. He was wise, he merely remarked it was an easy range and went away. We know a man who deals in eggs in the season. He told us he received postage stamps for 5s., and a request that he would forward eggs warranted to produce a cock and three hens, common Pheasants. We forgot to say it is very desirable the Creve-Cœur cocks should be entirely black, but like all black cocks, they will as they grow older throw coloured feathers. Yellow may be overlooked. Red are disqualifications.

COMMENCING PIGEON-KEEPING (R. M.).—The place you propose would do well enough for any but high-class delicate birds. We would advise you to start with Long-faced Tumblers, say Baldheads, or Blue Dragons or Antwerps; these are quite as prolific, bringing many pairs a-year, as common or cross-bred birds, just as healthy, and infinitely prettier. If you obtained a few young ones now they would pair and breed early in the spring. We are afraid that no Pigeons whatever, however common, pay at what you term "pot prices" if you have to buy all their food. But if you kept, say Dragons, they are strong of wing, and would, as you live in a town, soon get into the streets and pick up part of their living. You could also get charlock of the farmers, but it is an awful weed in the garden, and will become a nuisance if it be taken up with the manure to the manure heap. Young birds breed best.

INSECTS IN BACON (C. P.).—They are the common bacon beetles, Dermestes lardarius and their larvæ.—W.

METEOROLOGICAL OBSERVATIONS In the Suburbs of London for the week ending September 20th.

Table with columns: DATE, BAROMETER (Max., Min.), THERMOMETER (Air: Max., Min.; Earth: 1 ft., 2 ft.), Wind, Rain. Data for Wed., Thurs., Fri., Sat., Sun., Mon., Tues., and Mean values.

- 14.—Very fine; fine but cloudy; clear, starlight.
15.—Dense fog; very fine; foggy, fine at night.
16.—Foggy; fine, slight fog; clear and fine.
17.—Densely overcast throughout; heavy clouds.
18.—Densely overcast; fine, slightly overcast; densely overcast.
19.—Dense fog; densely overcast; clear and fine.
20.—Foggy; very fine; clear and fine.

COVENT GARDEN MARKET.—SEPTEMBER 21.

A VERY slack demand and a large supply do not admit of any improvement in prices; in fact, many articles have been left at lower offers than last week, the growers being anxious to effect sales. Potatoes are in fair request, and command about last week's quotations.

FRUIT.

Table listing fruit prices: Apples, Apricots, Chestnuts, Cherries, Currants, Black Currants, Fig, Filberts, Gooseberries, Grapes, Lemons, Melons, Mulberries, Nectarines, Oranges, Peaches, Pears, Pine Apples, Plums, Quinces, Raspberries, Strawberries, Walnuts.

VEGETABLES.

Table listing vegetable prices: Artichokes, Asparagus, Beans, Broad Beans, Beet, Broccoli, Brussels Sprouts, Cabbage, Capsicum, Carrots, Cauliflower, Celery, Coleworts, Cucumbers, Endive, Fennel, Garlic, Herbs, Horseradish, Leeks, Lettuce, Mushrooms, Mustard & Cress, Onions, Parsley, Parsnips, Peas, Potatoes, Kidney Potatoes, Radishes, Rhubarb, Savoy, Sea-kale, Shallots, Spinach, Tomatoes, Turnips, Vegetable Marrows.

WEEKLY CALENDAR.

Day of Month		Day of Week	SEP. 29—OCT. 5, 1870.		Average Temperature near London.			Rain in last 48 years.	Sun Rises.	Sun Sets.	Moon Rises.	Moon Sets.	Moon's Age.	Clock after Sun.	Day of Year.		
			Day.	Night.	Mean.	Days.	m.	h.	m.	h.	m.	h.	Days.	m.	s.		
29	TH	MICHAELMAS DAY.	65.5	44.3	54.9	25	58	af 5	47	af 5	19	af 11	16	af 8	4	9 49	272
30	F		65.0	43.3	54.2	24	59	5	41	5	after.	57	8	5	10 0	273	
1	S	Cambridge Michaelmas Term begins.	63.4	44.7	54.1	21	1	6	40	5	47	1	47	9	10 19	274	
2	SUN	16 SUNDAY AFTER TRINITY.	64.4	43.9	54.1	19	3	6	38	5	44	2	46	10	10 38	275	
3	M		63.7	41.5	52.6	16	5	6	35	5	31	3	52	11	10 53	276	
4	TU		63.7	42.4	53.1	21	7	6	32	5	5	4	morn.	9	11 15	277	
5	W	Royal Horticultural Society, Fruit, Floral, and General Meeting.	60.5	40.3	50.4	21	9	6	30	5	34	4	2	1	11 33	278	

From observations taken near London during the last forty-three years, the average day temperature of the week is 63.7, and its night temperature 42.9. The greatest heat was 80°, on the 5th, 1834; and the lowest cold 23°, on the 29th, 1842; and 30th, 1836. The greatest fall of rain was 1.68 inch.

CLIMBING FERNS.—No. 1.



HERE are a few Ferns to be met with in cultivation which do not in the majority of collections display their beauties to the greatest advantage: I allude to those few species of scandent habit belonging to several genera, many of which have the power of extending their fronds to an indefinite length. That these plants do not lack beauty I am positive, because I have grown all the kinds here enumerated into good specimens, and yet how

seldom do we see them properly treated; and let me add, in passing, these very plants can be made prominent objects in a fernery, diversifying its features, enhancing considerably its beauty, and thus increasing its interest. With the hope, therefore, that a few remarks upon these climbing Ferns may not be unwelcome, I purpose briefly describing the various species, and the best method of cultivating them, commencing with the genus

LYGODIUM.

As a genus this is characterised by its twining scandent fronds, which have the peculiarity of extending themselves to an indefinite length; the pinnæ are usually in pairs or are palmately lobed, but sometimes they are pinnatifid; the veins are forked and free, the sporangiferous receptacle is situated at the margin; and the sori stand out beyond the edges like little spikes, giving the fruiting fronds a distinct and very handsome appearance. In a state of nature these plants are mostly found growing in stiff loamy soil, and nearly always in the vicinity of shrubs or low bushes, over and through which their fronds are laced and twisted, draping their supporters with an exquisite mantle of bright green. In cultivation I have found *Lygodium* thrive well potted in two parts peat, two parts loam, and one part leaf mould and sand together. In potting, great care must be taken to prevent any accident happening to the drainage. Most of the species enjoy stove heat, and require a liberal supply of water, although some kinds will grow in a greenhouse temperature. A custom prevails with some Fern growers of cutting off the fronds of *Lygodium* quite level with the pot every spring; this, many say, makes them grow stronger, but nothing can be more directly in opposition to all natural laws, and I firmly believe it is only an excuse for hiding carelessness in the shape of scale-infested fronds; depend upon it the best plan is to remove pinnæ or fronds only when they become unsightly, and if ordinary care be taken in cultivation this necessity will not occur frequently.

L. japonicum.—The fronds of this species grow to a considerable length, and that very rapidly. When trained up and round the pillars of a Fern house, or indeed an ordinary stove, it produces a most beautiful effect, and it succeeds equally well trained along a rafter, or when used to form a screen for covering a wall; in either of these positions this plant is able to develop its beauties and display its true character, which is not the case when it is grown upon small trellises. Another use to which the fronds of this species are admirably adapted is for twining

round the stems of epergnes for the decoration of dinner-tables, &c., and I think I may safely venture to say that for this purpose it would be extremely difficult to find its equal for elegance and simplicity. The fronds of *L. japonicum* are branched, and the pinnæ are palmately lobed, whilst upon the apex of each lobe is situated a little spike of dark brown sori, which contrast beautifully with the bright green of the frond. This species will thrive in a comparatively cool temperature, and it seems to be extremely common throughout China and Japan.

L. flexuosum.—The fronds of this kind are much larger than those of the previously-described plant; indeed it is one of the largest species in the genus, the pinnæ are opposite, narrow, twice-forked, and frequently measure 12 inches in length, whilst the fronds attain a great length under genial treatment. As in all this genus, the sori of this kind are exerted, and form a rich brown marginal border to the deep shining green of the pinnæ. It requires a stove temperature, and may be used with advantage in all the situations recommended for *L. japonicum*, saving the dinner-table stands, and from this its size excludes it; on account of its size, also, it requires a greater space to ramble over. It is sometimes called *L. dichotomum*, from the peculiar branching of its pinnæ, and is widely distributed throughout the islands in the Indian Archipelago.

L. palmatum.—This species is not a large grower, and is only sub-scandent, and perhaps should not have been classed with these. I have used it, however, to hang down from a pocket in the cool fernery with great success; the somewhat broad præmorse barren pinnæ, and the curious contracted finger-like fertile ones, presenting a unique appearance, and the sight of this plant well grown in such a position never fails to arrest the attention of Fern lovers. It is a deciduous plant, a native of North America.

L. scandens.—This kind resembles *L. japonicum* very much in some of its stages of growth, and, indeed, by some authorities they are considered identical. This may be the case, but yet when the two extreme forms are in a collection they certainly deserve distinct names. The form now under consideration is equally beautiful with that already described under the name of *L. japonicum*, indeed it is even more finely divided; the fronds extend indefinitely; the pinnæ are palmately lobed and of a beautiful bright green in colour, the fertile ones clothed at the margins with light brown sori. For covering a rafter or pillar in the stove it is admirable. Native of the East Indies.

L. polystachyum.—A noble large-growing species, producing large fronds with pinnæ from 6 to 12 inches in length, or even more, the stems clothed with a short white tomentum; pinnules obtuse, 3 or 4 inches long and 1 broad, deeply lobed, each lobe being much contracted towards the apex, and upon the under side of these contracted parts the dark brown sori are produced, and not exerted as is usual in this genus. A highly desirable plant, not sufficiently known or grown by lovers of Ferns. Native of the Indian Archipelago.

L. microphyllum.—This is a superb plant, but the form which I have grown seems to be extremely rare in cultivation. It produces elegant bright green barren pinnæ, whilst

the fruiting pinnae are reduced to little brown fruiting lobes, which contrast beautifully with the bright green. For a pillar this species is an especial favourite of mine, and it would be one with every Fern-grower if it were better known. This form is a native of the Philippine Islands.

LYGODICTYON.

In their general habit and appearance the plants composing this genus are exactly similar to the Lygodium, and they are distinguished from them only by having reticulated veins. This, however, amongst an order of plants in which the venation is of far greater importance than in any other order, is a good and abiding character. The soil and treatment should be the same as for Lygodium.

L. FORSTERI is a very handsome scandent plant, producing bipinnate fronds, which are several times forked in a dichotomous manner; the pinnae are oblong-obtuse, the sterile ones longer than the fertile, but the latter are much the broader; the sori are dark brown, dense, and exerted as in Lygodium, thus rendering it a most attractive plant for rafters or pillars in the fernery. It thrives well in the stove, but it will also attain considerable proportions in a cool house. Native of the Polynesian Islands.

GYMNOG MM

A genus very popular, and known to most plant lovers by the names of Gold and Silver Ferns, about which I hope to say a few words in a future article. The species to which, however, I wish to draw attention in this place is a climbing plant, and well merits the attention of Fern-growers. It requires a stove temperature, and should be potted in peat and sand only.

G. FLEXUOSA.—This most elegant plant produces fronds of an indefinite length. The rachis is zigzag, and the pinnae are bi-tripinnate and refracted; pinnules narrow and somewhat wedge-shaped; it is entirely destitute of the farinose powder so common to the genus, and dark green in colour. It climbs over bushes and shrubs in its native habitats, and its light graceful fronds produce a charming effect. Native of South America.

PLATYLOMA.

This genus contains several very handsome species; only one, however, can be introduced here as a climber, and it should find a place in every collection of Ferns on account of its extreme beauty, its distinctness, and because it succeeds well in a cool house. This genus is characterised by its forked veins, and by the sporangiferous receptacles being terminal and oblong; these, being contiguous, form a broad unbroken marginal sorus; the indusium is linear, continuous, and very narrow. Rough fibrous peat and sand, with a little light loam, suit this genus admirably.

P. FLEXUOSA.—This is sometimes to be met with under the name of *Allosora flexuosus* and *Pteris flexuosa*; it is a most elegant plant, and produces a fine effect trained upon a rafter or pillar. The fronds are 6 or 7 feet in length, tripinnate, with a zigzag stem; the pinnules are small, ovate, and light green in colour; the sori form a continuous marginal band on the under side, greatly enhancing its beauty. As before remarked, it thrives well in a cool house, and is a native of various parts of South America.

ADIANTUM.

Under the name of Maiden-hair Ferns the genus *Adiantum* is familiar to all lovers of plants. All the species are handsome, and some of them rank amongst the most beautiful Ferns in cultivation. The fronds vary from simple to pinnate and bi-tripinnate, with jointed pinnae, which have an excentric costa or midrib; the veins are forked and free; the sori marginal, and covered by a conspicuous indusium. Only one scandent species has up to the present time been introduced in a living state to our gardens, although other handsome climbing kinds are known to exist in tropical countries. It should be potted in peat and light loam.

A. FLEXI is a distinct form of Maiden-hair, and cannot be mistaken for, or confounded with any other species. It is known in some collections by the name of *A. flexuosum*. Its fronds extend to a considerable length; they are tripinnate, having the rachis and petioles covered with a reddish-brown pubescence; the pinnae are sub-rotund, and dull green in colour. It forms an elegant plant either for pillars or rafters in the stove fernery. Native of Mexico.—*EXPERTO CREDE*.

IPECACUANHA CULTURE.—According to *Nature*, there is good report of the progress of *Ipecacuanha* cultivation in India, where it is found so valuable in that prevalent disease, dysen-

tery. Since Dr. John Murray obtained for it the notice of the Indian Government, it has been successfully planted in the Neilgherries and other of our hill settlements, and in the plains. It has done well even at Calcutta.

NUTRITION AND SEX IN PLANTS.

(Read before the American Association for the Advancement of Science.)

In my paper on the laws of sex in plants, which I read to the Association last year, I gave some account of a few of the leading facts I had observed, which seemed to indicate that a higher degree of vigour or vital force was necessary to produce the female than the male sex in plants. I have not met with one fact which has suggested any other conclusion; nor have I heard any fact suggested by others which could lead to any other opinion. Wherever there has been any change in the sexual relations, the male flowers or organs are invariably associated with declining vigour, while only in those parts of plants most favourable to the highest state of vitality are the female flowers most numerous or generally found.

This theory is so capable of easy demonstration by anyone who will personally examine the first monoecious tree or plant he meets, that I feel sure nothing further will be needed from me to sustain it. I propose now to go a step further, in the endeavour to ascertain the exact laws of nutrition, by which we may control these sex-producing forces respectively.

I have here some specimens of *Castanea americana*, our common Sweet Chestnut, as my first contribution to this class of facts.

But first I would call attention to the fact that there are two classes of male flowers in this tree. It is scarcely possible that this should have escaped the eye of other observers, but I find no reference to it in botanical works. One class of male flowers comes out from the axils on half-starved shoots, the other class terminates the strong vigorous shoots which bear the female blossoms. Those of the former class have their flowers set densely on the rachis—on the latter they are somewhat scattered, and do not open until a week or ten days after the latter. The numerous flowers we see on the Chestnut trees are of the former class, and generally have mostly fallen before those associated with the female flowers open. I think it likely that one of these classes does not perform the usual fertilising functions, but could not satisfy myself positively. The interest for us here is to note the antagonism, so to say, between the male and female blossoms. The comparatively weak spikes show that they were formed only after the female flowers had received matter enough for their perfect development. Only the surplus matter goes to form the male flowers at the apex. This is better shown by the fact that often there is no prolongation beyond the female flowers—no male blossoms; at other times only a few—never, as we have seen, the number which appears on those spikes which are wholly masculine in their nature.

In regard to the influence of nutrition on sex, another specimen I exhibit is from a tree at least 40 feet high and 6 in circumference. It is on my ground, stands out by itself, and has borne fruit regularly and in good crops annually. This year the leaves are all streaked with yellow, as in this specimen.

Horticiculturists well know that this appearance on the leaves of plants arises from an interruption of the nutritive functions. If a branch be partially ringed to induce fruitfulness, or if the roots be injured in transplanting, or rotted by an over-supply of water, a yellow tint to the foliage is the invariable consequence. In some way, then, this Chestnut tree has this season met with some check to its nutritive system,—received a blow to its vitality, which has resulted in this yellow-tinted leaf. The effect of this on the sex is, that though thousands of male flowers are produced, there is not one female flower, one young chestnut, on the whole tree that I can find.

I think this instance satisfactory as far as it goes, that defective nutrition is one of the agents which operate on those laws of vitality that govern the sexes.—*THOMAS MEEHAN.*—(*American Gardener's Monthly.*)

GARIBALDI STRAWBERRY.

I OBSERVE in your issue of the 8th inst. that a correspondent says the Garibaldi Strawberry which I raised has been proved to be *Vicomtesse Héricart de Thury*, and that the latter has been sent out under the name of Garibaldi as a new Strawberry. I beg to deny any such assertion, and further beg to state that when the *Vicomtesse* is grown along with the *true* Garibaldi it will be found that my Strawberry is much superior

in many respects. Your correspondent further asserts that Garibaldi was sent out last year; allow me to inform him that I sent it out five years ago. If he will write me on the subject I shall give him sufficient references. I have only to add that at present Garibaldi stands unrivalled.—T. ARMSTRONG, *Belah Gardens, Stanweir, Carlisle.*

THE SLOUGH CARNATIONS AND PICOTEEES.

Now that florists' flowers are once more looking up, and we are, I hope, likely to see more of them in the metropolis than we have done during the past few years, I shall be justified in drawing attention to some of them as they come under one's notice; and having had an opportunity of seeing Mr. Turner's collection of Carnations and Picotees in full bloom, an account of what I saw cannot fail to be of interest to some.

It was on my return journey from Okeford Fitzpaine and Salisbury that I found myself at Reading and enjoying the hospitality of some kind friends there, who much wanted me to go with them the next day to the Oxford Show. The weather was insufferably hot, and I heard so poor an account of the show and the difficulty of getting about, that I would not go. Instead, I determined to visit the classic grounds of Slough, one of the choice spots of "merrie England" to the florist, for has not there the very prince of florists set an example to all lovers of flowers as to what can be done? From thence he has brought forth artillery that has ranked the finest competitors. In Azaleas, Pelargoniums, Roses, Auriculas, Dahlias, Pinks, Carnations, and Picotees he has shown himself a very giant; and for neatness, order, and well-kept grounds it would be difficult anywhere to find the equal of Slough. I knew that the best twenty-four Picotees and Carnations had gone off to Oxford, but knowing how extensive his stock was I felt sure this would make no very perceptible difference: nor was I wrong. Independently of the large stock in pots out of doors, a lean-to in a northern aspect was filled with a splendid collection in fine health and full bloom. Ball, the intelligent and able cultivator of these and the Auriculas, was at home, we had a good hour's chat over our favourites, and I here give the result of my observations, seconded by his greater experience.

In PICOTEEES I would place at the very head of the list, as possessing the finest qualities, a flower sent out by Mr. Turner last year—Admiration. It is a heavy-edged purple Picotee, of splendid habit and first-rate properties. Wherever it was in the house it was at once recognised by its fine habit and appearance. It is some satisfaction to know that this, one of our newest flowers, is also our very best. Miss Turner is another very beautiful flower of a different character, a light-edged red, with a very pure white ground and a medium edge of bright red. These, with Charmer, medium purple edge, very constant and distinct; Colonel Clerk, heavy red, with broad smooth petal, large, full, and regular; Mrs. Fisher, a light-edged rose, fine and full, good ground, and beautifully marked; and Nimrod, a rich dark purple, were among the newer flowers that struck me as being fine.

Amongst older flowers, in heavy-edged red kinds Exhibitor, Favourite, Mrs. Dodwell, Mrs. Norman, and William Summers may be set down as excellent; while in light-edged red Agnes, Miss Holbeck, Mrs. Kelk, and Penelope are equally good. In heavy purple-edged, Lord Nelson, Prince Arthur, Duke of Devonshire; and in light purple-edged, Amy Kobsart, Bridesmaid, Mary (a very beautiful flower), and Lady Elcho are flowers of first-rate excellence. No class is a greater favourite with me than the rose and scarlet-edged Picotees, and Mr. Turner's collection was especially rich in them. Miss Meeking, Queen Victoria, Princess Royal, Rosalind, and Unexpected are very fine; while amongst light-edged varieties Lucy, Miss Sewell, Miss Paxley, and Rosy Circle are exceedingly beautiful. I have in these marked only those which seemed to be not only beautiful but good growers; for in all flowers, no matter what they may be—Roses, Auriculas, Carnations, or Picotees—unless we have good constitution beauty is of little moment. They only tantalise us by their beauty which we enjoy but for a little while ere it perishes.

Amongst the recently raised CARNATIONS the following may be regarded as valuable varieties:—Annihilator, a good scarlet flake, good white ground and bright marking; Eccentric Jack, large and well-marked crimson bizarre, good shape with broad petals; James Merryweather, rose flake, a fine variety, good habit; Rifleman, crimson bizarre, very large bold flower, will be probably a great favourite in the north; William Cowper, a fine flower, scarlet flake, and very constant; and Graceless

Tom, a fine full-sized crimson bizarre, well-marked and constant. Amongst scarlet bizarres of older date the following were good:—Flambean, Lord Raneliffe, William Pitt, and Brutus. Of crimson bizarres, Jenny Lind, Paul Pry, Queen Victoria, and Lord Milton are fine varieties. Probably the best of the purple flakes were Ascendant, Earl Stamford, Mayor of Oldham, and Mayor of Nottingham. In scarlet flakes Christopher Sly, Justice Shallow, Lydia, and Illuminator are good; and in that charming class rose flakes Flora's Garland (a difficult flower to grow), Lady Ely, Princess Royal, Rose of Castile, and Samuel Moreton are very fine.

In mentioning these I have only selected a very small portion of what I saw, as they seemed to me to be amongst the finest; but in so extensive and varied a selection there was such an *embarras de richesses* that one was fairly confounded by it. Let those who may think of growing them put themselves into the hands of an experienced grower like Mr. Turner, and they will not fail to make a good start.—D., *Deal.*

PEACHES AND NECTARINES.

DR. HOOGE'S "Fruit Manual" is a very useful book. It, by giving the synonymes, and describing the shapes of the fruits, the forms of the stones, and the size of the flowers and the glands, has enabled me to find out deceptions, and to determine the varieties of misnamed Peaches and Nectarines. I hope we shall soon have another edition, describing the latest seedlings, and also distinguishing the colours of fruits grown under glass from those grown out of doors, as they are very different. By the help of this excellent work I found out that I had the Grosse Mignonne under three synonymes—namely, Royal Kensington, Padley's Early Purple, and Smooth-leaved Royal George. These four synonymes, of course, quadruple the chances of sale; but the act is dishonest. I advise purchasers of the above fruit trees to try the sorts sent out by means of the flowers, the glands, the shape of the fruit, and the serration of the leaves. A powerful glass is necessary to examine the glands, which are either kidney-shaped or round. The glands are sometimes so small that the unassisted eye cannot always determine their shape. It is said that glandless leaves are subject to mildew; under glass it may be so, but I never saw mildew on the leaves of my Peaches and Nectarines out of doors.

As soon as the Peach and Nectarine season is over, I think of referring to the fruits, especially to those of later origin. In the meantime I express my gratitude for such a magnificent crop of fine fruits. I have cut in half the leaves of all the trees that have done fruiting. It is a good plan, practised here successfully for two years, as it enables the sun and air to mature the wood of the current year, upon the ripening of which future success greatly depends. The skin should be blood red, and not of a pale sickly green.—W. F. RADCLIFFE.

THE ROYAL HORTICULTURAL SOCIETY'S HYACINTH SHOW.

I SHOULD very much like to call the attention of the Council of the Royal Horticultural Society to two points in connection with the show of Hyacinths, &c., annually held by the Society.

Firstly, the low value of prizes offered, and, consequently, the little encouragement given to the flowering of these bulbs. I believe the number of exhibitors at this Show decreases year by year, and I think the principal reason is because the prizes offered are not of sufficient value. I have been a successful exhibitor of Dutch bulbs for three years, and I can confidently state I have barely covered my expenses. I do not mean to say I want to make a profit of these exhibitions, but I do mean to say that if more adequate prizes were offered more persons would be induced to enter the field, and the Society would benefit by the results. I certainly am of opinion that the growth of these spring flowers cannot be too much encouraged, coming, as they do, at a time when the first days of warmth occur, and when flowers are so highly prized.

Secondly, I think if the Committee were to issue a spring schedule distinct from the summer one, and at an earlier date than usual, both the Society and exhibitors would derive a great benefit. Dutch bulbs are not like plants which a man has in his possession, it is necessary to procure fresh ones every year, and the growers recommend an early purchase; but how is an intending exhibitor to know what to purchase if

he does not know what he has to exhibit? I should like also to see more classes open to amateurs.

I have made these remarks as one who takes an interest in the welfare of the Society, and I hope the Council will receive them as such.—AMATEUR.

CAPEL MANOR, HORSEMONDEN, KENT.

CAPEL MANOR is a commodious edifice in what is called the Lombardic style of architecture, situated midway on the slope of a gentle eminence facing the east, in the picturesque parish of Horsemonden, five or six miles from the Paddock Wood Station, on the South-Eastern Railway. The surrounding country presents a series of undulations, all available for tillage, but sufficiently elevated to afford commanding sites for dwellings without bleakness, being well wooded, and for miles having a clothed appearance. Perhaps nowhere are Hops and fruit trees more industriously attended to, and with more successful results. The gentle hills and smiling valleys teem with vegetable life, exposed to no smoke from factory chimneys; for although report says the iron of the railing round St. Paul's Cathedral was smelted in an adjoining parish, the furnaces that supplied it have long since passed away, and so has the manufactory of woollen cloth, for which the village of Horsemonden was at one time famous. The cultivation of the ground has been all the more actively engaged in, the nature of the soil and the undulating character of the country being favourable. The district contrasts strongly with the level tract of land to the north of it, forming what is called the Weald of Kent; the high ground of the parishes of Horsemonden, Goudhurst, Cranbrook, and Frittenden overlooking this flat on the one side, as the high ridge of hills forming the Coxheath range does on the other; and it is partly owing to this cause that from the tower of Goudhurst church, although the village is situated at no great elevation, it is said fifty-two other churches may be seen, and possibly no village within this range of view contains five hundred inhabitants.

Only eleven years ago the site of the mansion and grounds was a wood and meadow, but so well adapted is the soil to the growth of shrubs and trees, and so carefully have they been planted and tended, that the place presents a clothed appearance already. One circumstance, no doubt, contributed to this result—there were plenty of large Oak and other trees about the mansion and its surroundings, as well as in the park, so that these essential features were already provided, for although the place is quite new, it is very near the site of a very old residence that used to be the home of the ancestors of the present proprietor. —Austen, Esq. With laudable consideration the park and adjacent fields had never been denuded of their timber, as so many estates were about the beginning of the present century, when oak commanded so high a price, consequently the park is amply, nay, profusely, furnished with trees of all sizes.

The mansion is built of a light coloured sandstone found in the neighbourhood, with stone of another sort for dressings, and its cleanliness contrasts well with the healthy herbage by which it is surrounded. The carriage front faces the north-east, while the south-eastern and south-western sides are garden fronts, the offices being on the other side. Situated on a declivity facing the south-east a terrace runs along that side with an enriched architectural retaining wall and parapet, while below is a large basin of water, with some beds edged with stone on a spacious gravelled area, contrasting strongly with the cramped arrangements of some gardens of a like kind, where the design would seem to be to get as much as possible into the smallest space. Suitable flights of steps lead down from the upper terrace, while below, the dressed grounds extend some distance as shrubbery, intersected by walks conforming to the inclination of the ground. A summer-house forms a termination to one of the walks in this quarter. On the south-west side the ground is more on a level with the base of the mansion, and a flower garden on turf is suitably placed there, as well as a very neat conservatory upwards of 70 feet long by about 28 feet wide. This adjoins the mansion, and is well clothed with climbers in robust health; amongst them I noticed a fine plant of *Lapageria rosea* blooming profusely. *Passiflora Buonapartea* was in excellent health, and was said to have bloomed well, while a *Thibaudia* growing against one of the ends of the building presented several clusters of its tubular flowers in great profusion. The shelves and central beds were well filled with healthy flowering and fine-foliaged plants, and presented a gay and interesting appearance, meeting the

climbers from the roof, and showing a high state of cultivation. Encaustic tiles formed the pathway, which had a stone kerb, and the workmanship of the whole building was of the best description. I believe Mr. Ormson erected it, as well as the other forcing houses which will be described hereafter.

The dressed grounds are very extensive, and differ from those at many places of a like kind, the walks being in most instances straight and pointing to some object either placed there to form a suitable terminus, or directed to some feature in the distance. The picturesque village of Goudhurst, about two miles off, was brought into view, while a summer-house formed a suitable termination at another place. Most of the walks diverging from the principal ones were also at right angles, thereby dividing the ground into a series of squares and parallelograms, one of which had been devoted to that which has now become an important appendage to most country houses, a croquet ground. Beds of Tea and other Roses in excellent health, with abundance of flowers even at the time of my visit (the end of August), were also met with at various turnings, while the choicest Pinuses had suitable positions, and some steep banks and other inequalities were well clothed with shrubs of various kinds, amongst which I noticed *Escallonia macrantha* luxuriating almost as well as a *Laurus tinus*, while trained against the mansion *Magnolia grandiflora* was flowering. On a prepared border near the conservatory a large bed, or rather bank, of the best varieties of *Rhododendrons* must present a gorgeous sight when in bloom. These shrubs, it must be observed, were here and there backed by good old Oak or other trees, and the rear of the mansion was well sheltered by trees on still higher ground, giving the whole an appearance of snugness.

The kitchen garden and forcing houses also lay in this direction. The garden proper is surrounded by good walls well covered with fruit trees bearing luxuriant crops. The Peaches, Nectarines, and Plums could not well be excelled, and the same may be said of some Morello Cherries on a north wall. Accompanying the latter was a late table Cherry, which Mr. Seale, the gardener, said he believed was a Late Duke Cherry of some kind. Outside the garden was more than the ordinary amount of slip, for the space far exceeded that enclosed by the walls, and was devoted to the growth of hardy fruits and common vegetables. Very heavy crops of Plums, Pears, and Apples on standard trees eight or nine years old, proved how well the situation and treatment suited them.

In the hothouses heavy crops of most excellent Grapes were grown; the varieties were Black Hamburgs, Muscat Hamburgs, and White Muscats, remarkably fine for size of berry. The stems of the Vines showed a sturdiness of growth rarely met with in plants so young, while the foliage was not at all large, confirming what I have before advanced, that size of leaf alone is not the criterion of the Vine's doing well. The fruit from the early house had been mostly gathered, but an abundant crop was coming on in a later house. A Fig-house had also yielded well, and the trees were showing a second crop. The walls were everywhere closely covered with healthy fruitful trees, and the interior of the garden showed, by the abundant crops of vegetables, that the soil and its management had been such as to successfully combat the very dry season. Even Peas were in bearing, although much attacked by birds, which threatened to destroy that crop.

As the natural character of the soil has always much to do with the well-being of every crop, the worthy proprietor of Capel Manor and his energetic gardener have been fortunate in this respect; but the soil is one not easily described, unless the equivocal term of a stiff sand be applicable, for it was of that character—a light coloured material free from stones, but not so porous that water would not stand upon it when it was kneaded together. Underneath was the sandstone of which the mansion and other buildings were constructed. This soil, I feel convinced from what I saw, is more conducive to the well-doing of the Vine than so much lime rubbish as is advocated by many, and although pale coloured I believe it contains iron, for at a short distance from the garden the bed of a little streamlet exhibited a bright red incrustation. The soil of the kitchen garden, as well as of most parts of the pleasure grounds, was also of good depth. The latter, however, had mostly been disturbed, so that the original surface was only to be guessed at; however, I may state that *Rhododendrons* seemed to thrive tolerably well in it, although not so well as in some borders made for them by an admixture of bog peat from a swamp in the park. This class of soil pervades much of the district to the eastward of Tonbridge Wells, as well as around

that fashionable town; it is a soil that must not be meddled with when it is wet, but when properly tilled, and the season is favourable, it works like velvet, as a farmer friend observed, its texture being so fine. Most trees seemed to thrive well in such a soil, as well as many vegetables; perhaps the Cabbage tribe required more lime.

I cannot draw this communication to a close without mentioning that the Apricot was succeeding better than it does in most places, for it is often in an unsatisfactory condition; here the trees were healthy, well-formed, and fruitful. It may be said they are young, only nine or ten years old at most; but Mr. Seale took me to look at a couple of old trees growing against a house, which two centuries or more ago was the dwelling of his employer's ancestors. This residence stands on the edge of the park, in lower ground than the present mansion, and is one of those timber-framed buildings with the upper storey overhanging the lower one, which are now less frequently met with than formerly, though they have not entirely vanished from our old towns. Against this residence were two Apricot trees that might almost equal it in antiquity; they were standards, or what are sometimes called riders, with stems showing but few symptoms of decay, certainly nothing of the shell-like character which such trees often present even when the top is healthy. The circumference of one was 45 inches, and that of the other 38 inches at the smallest part of the 5 or 6 feet which formed the bole. Mr. Seale thought they were of the Breda variety, and that their age was from 150 to 200 years. The soil, although partaking in some respects of that of the rest of the garden, was much less inviting at the spot where the trees were growing; nevertheless, there they were, showing that in a suitable soil the Apricot is a much longer-lived tree than it is often supposed to be. The tops, though showing signs of great age, and no doubt affected by a drain having been cut near, still possessed sufficient health to warrant the belief that they would outlive another generation, and the fruit was said to be as good and as plentiful as from younger trees of the same variety. Some other old trees and shrubs surrounded this ancient abode. The Yews were not at all satisfactory, but some old Box trees had attained unusual dimensions, showing that although certain soils and situations will grow almost anything, there are, nevertheless, species which thrive better than others in particular soils.

I have, in conclusion, to thank Mr. Seale for his courtesy in pointing out the various features connected with this fine place, and hope both he and his employer will long enjoy the grounds they may be said to have created, and which they have furnished in so short a time.—J. ROBSON.

STOCK SPREADING TO THE SCION OF A PLUM TREE.

I saw recently at Yatton Keynell Rectory, Wilts, a Plum tree nailed to a wall. It had made to my mind a remarkable sport. The tree was grafted low, as usual, and immediately above the graft it branched out, covering a good space of wall. From one limb there had issued, about 4 feet from the ground, a branch of the pure wild stock, while below it was a branch on the opposite side bearing the proper fruit, and just above another piece also bearing the same. Is this kind of growth very uncommon, and what can be the cause?

A friend's Laburnum tree has made a sport which bears purple flowers. Will the seed from those flowers, produce plants bearing purple flowers?—A. H.

[Most probably not. The influence exerted by the stock over the scion is subject to many anomalies, and they, as well as sports in the colours and forms of flowers, are among the unexplained facts of the vegetable kingdom.—Eds.]

STOCKS FOR APPLE GRAFTS.

CAN some of your arboricultural or pomological genealogists favour us with the pedigree of the Apple stocks called *English Paradise, French Paradise, Pommier de Paradis, †Doucein, Burr Knot, and Sühhert, and describe any characteristic peculiarities of growth, and hue of bark and foliage? We have heard many wonderful tales of dwarfing stocks such as are named and of precocious crops from such stocks, and it would be as interesting to learn how nearly allied to the Crab or Apple these some-

what alien stocks are, and how far the produce is that of hybrid or pure Apple culture.

I am but an amateur, though I will venture to say that the Crab alone is the stock for fruit true to itself in colour, flavour, and size alike. The genus of the stock and the scion, whatever variety of Apple is grafted, is the same: hence the truth of the produce. And dwarf Crab stocks are, I think, drawn from Crab seedlings constitutionally so, the stouter seedlings going for standard trees; at least I have dwarf Crab stocks robust, round, and dwarfed, and pyramidal, in my ground. But though the Crab is my choice, the history of the Paradise, and other stocks would present to your readers the choice of stocks in use by our nurserymen. And can we be told to what extent the Apple stock from Apple seedlings—the cultivated Apple, not the Crab or wild Apple stock—is used, and its results?—READER.

HORTICULTURE AMONG THE MORMONS.

ON our tour to California we spent a few days very pleasantly at Salt Lake City. The houses of the inhabitants are embowered among hundreds of choice shade trees along all the public streets, while the gardens are full of fruit trees of great health and luxuriance. We could hardly believe that, only a month beforehand, a plague of grasshoppers had descended from the mountains and cleared the gardens and trees of every living leaf, and now all was bright and cheerful again. The trees were loaded with fruit, and Apples, Pears, Plums, Apricots, and Cherries were hanging with ripe specimens from nearly every tree. It is curious to see the Apples hug the branches and stem, as closely as if fitted for their place, while with us every fruit hangs from a twig or dangles from the end of a limb. The climate is exceedingly favourable, frosts rarely occurring after vegetation has really started in the early spring. The days are always pleasant, rarely very warm; the nights always cool, with agreeable breezes; and the abundance of water for irrigating purposes favours the growth of almost every species of fruit. Elder Smith showed me a row of Apricot trees, planted eight years ago from seed obtained from the Department of Agriculture at Washington. They had been fruiting four years, were an average of 15 feet high, and proved to be of four different kinds. The specimens we saw, left from the attacks of the grasshoppers, were as large as a good-sized Peach, and fair quality, but not as delicate in flavour as our own varieties of the Atlantic States. The Peach trees have more compact heads, less spreading, leaves are of a deeper green, leading shoots do not grow quite as long. We have more side shoots than they, but the entire top of their trees is a mass of dense leaves. No cures, borers, or insects of any description are known. The yellows have never been seen, and apparently there is no natural enemy. The Apple tree bears in two years from cuttings or grafts, and fruit is beautifully coloured. Several specimens of Red Astrachan and Sweet Bough Apples attracted my special attention; the latter for its size, being 12 inches in circumference; the former for its deep bloom, which, when brushed off, revealed a brilliant red-coloured surface, equal to the tints of the rainbow, or the finest sun painting on the clouds of a sunset sky. We have nothing to equal it. Undoubtedly the dryness of the climate, and the soil composed of the washings of the mountains, helped materially in the rich colouring of the fruit. All the soil is full of mineral matter, and this exerts its natural effect in high colour.

The best garden of the place is that of Mr. William Jennings, the richest man of the entire territory, and a successful merchant, who favoured us with conveniences for a visit to his garden. His home grounds occupy about five acres, devoted almost entirely to fruit. A lovely lawn in front of his house, with its deep velvety green carpet, was skirted with rows of flowers, Fuchsias, Dahlias, Roses, Geraniums, and Lilies. From the balcony windows of the parlours we catch an exquisite view of the snow-capped mountains of the distant ranges.

The city is surrounded in all directions with lofty peaks, varying from ten to fifty miles distant; and many with snow-topped summits, glittering bright and brilliant against the deep blue sky.

Cherries are a favourite crop with the proprietor, several varieties being planted, of which the Napoleon Bigarraan is most favoured. The flavour is more rich and exquisite than with us, but it is not so finely coloured. With the other kinds the family enjoy Cherries for a season of six weeks.

Peaches were thriving admirably. In fruiting time they have gathered specimens fully 13 inches in circumference.

* Query, if dwarfed Crab stock.

† Query, if French Paradise stock.

Strawberries are abundant, and throughout the entire bed will average 4 inches in circumference. The Wilson and Longworth Prolific are the best. Agriculturist, Jucunda, and a dozen others imported from the Atlantic States, have proved a failure.

Grapes are successful beyond measure. The Black Hamburgh, which we in the east must grow under glass, here is free and luxuriant in the open air; as also are the Chasselas, Sweetwater, White Frontignan, &c. Bunches of the Sweetwater have often been picked as big as a man's hat, and weighing over 10 lbs. Gooseberries are large and sweet, almost of the size of Crab Apples.

The Delaware, Uniou Village, Catawba and a few other eastern Vines, are grown with success; and yet are mere pigmies by the side of the noble Hamburgh and Chasselas. Apricots, Almonds, Mulberries are everywhere successful, while Currants are luxuriant to a fault.

Asparagus is fully equal to some of the specimens of our famous Conover Colossal. Of Plums, the Green Gage and Magnum Bonum are much the finest, still not very productive. Potato beds had suffered greatly from the "hoppers;" the leaves had been stripped and the tubers become watery. Still, very fine specimens of the Early Rose were dug, and pronounced of superior flavour by Mr. Jennings. The Ash-leaved Kidney is also successful, being perhaps the finest flavoured of all he had tried. The White Ash-leaved is nearly equal to the Early Rose. Mulberry trees are very thrifty. The people are now engaging in their culture for raising silk. The growth is very rapid, usually 4 feet a-year, but Mr. Jennings mentions several instances of 11 feet a-year from cuttings. The Sweet Almond is at home by the side of the Plum and Peach, bearing fruit.

Mr. Jennings has some very fine Vines of the Mission Grape, so universal in California. They bear large loose clusters, have short but very thick-jointed shoots, some of the joints being nearly an inch in diameter. The fruit is fine for table, and universally made into wine. The Buckland Sweetwater Grape grows with perfect vigour, and produces bunches large enough to fill a hat.

The Muscatel is also adapted to the climate. Specimens were shown us of an Improved Rocky Mountain Currant; berries as big as Cherries, and 2½ inches in circumference. The bush is large, fully 6 feet broad, and above 4 feet high; colour of fruit deep black; flavour sweet for a Black Currant, but best fitted for preserves. On the posts near the entrance to the house were specimens of the Mexican Cacti thriving in the open air. What a singular sight to behold—on the one side Apples from the east, Grapes from the west, tropical plants from the south, the Almond from Europe, flowers from the Atlantic States, lawn Grass from England, while over-topped by all are the unchanging mountains, always girt with snow, and picturesque in their contrast with the verdure beneath!

Mr. Jennings's place is an exception to the general character of the gardens of the inhabitants. Some are very neat, but usually the gardens of the Mormons are not well kept; perhaps the devastation of the hoppers has taken away their enthusiasm, for we saw an abundance of weeds in many gardens, and not a soul working therein.

Evidently everything is left to climate and water, and only at occasional long intervals the gardener appears and cleans out the weeds.

The soil is dry and gravelly. It would naturally be poor and worthless, but the long streams of water come rolling down, and behold the leaves grow of a deeper green, and their life is renewed again and again.—(*American Horticulturist*.)

WAYSIDE JOTTINGS.—No. 6.

Just before reaching the summit of the "hawse," an amusing incident occurred. The Doctor had diverged from the track to the right with the view of reaching the summit of Cockup, which overhung our path in that direction, by making a detour which would lessen the difficulty of the ascent. About a hundred yards farther on, the Squire and I decided upon making a similar attempt where the path to the top was considerably more abrupt and precipitous than that adopted by our comrade. We were induced to take this step by a desire to examine some tufts of vegetation which we saw springing from the crevices of the rock overhead, and which we could not identify at our present distance. The Doctor had by this time disappeared from our view, though his shrill whistle could occasionally be heard reverberated from the crags around and above us. Just

as we were about to encounter the only remaining obstacle to our safe ascent, the Squire suddenly declined to pursue the attempt further, affirming that his head was becoming affected with premonitory symptoms of vertigo. Reaching the head of my staff towards him, I exhorted him to persevere, but my eloquence was tried in vain. "I have no desire needlessly to imperil my limbs; and recollect," added he humorously, pointing to the game bag slung from his shoulder, "the claret bottle is here. Supposing any mischance should happen to the wine flask." I replied, directing his attention at the same time to a limpid stream far below, which was leaping from rock to rock, and glistening in the sunshine like a silver thread, "We might be worse off. Remember the rapturous words of the Roman poet—

"Dulcis aquæ saliente rivo restinguere sitim."

"That's all very fine," was the rejoinder, "but let us get down." Just at this point we were startled by a rumbling noise among the rocks above us, towards which we quickly turned our eyes, half expecting to see our medical friend making a somersault over the edge of the precipice which separated him from us. A moment's suspense revealed to us the cause of the noise, as the Squire's favourite pointer, Nino, unable to stop the momentum of her downward career, sprang from the ledge and alighted with a thud upon her master's bill-cock. This probably saved the poor animal from serious injury, as it served to break the force with which she finally landed among the scree below. As it was, she limped with pain for the rest of the day. Being shortly rejoined by our friend, we began to descend the opposite side of the pass, until we arrived at a small and rudely-formed sheepfold, close to the brook above referred to. Here a halt was called, and the sandwich case and wine flask being produced, their contents were discussed to our very great comfort and satisfaction. A more appropriate place for the purpose of a mountain luncheon could hardly be imagined. The sward of the diminutive fold was of the most vivid green, and cropped as no lawn mower, Archimedean or Siens Messor, could accomplish the task. Blocks of the schistose rock, the staple of Cockup, formed the boundary of the inclosure, among which, at every available opening, the beautifully curled leaves of the Parsley Fern or Rock Brakes sprang forth in every imaginable variety of form. In the brook close to our feet little fishes played, one of which, a sprightly burn trout, was momentarily made a prisoner for our examination, and having been submitted to a close scrutiny, was returned to his native element, evidently none the worse for his vigorous bounding on the green turf. Several hundred feet above our present level, on the broad shoulders of one of Cockup's bigger brothers, named Calvo, a large flock of rocks were enjoying themselves, busy scanning the turf for the grubs or larvae of the Tipula, which often abound on elevated moors.—II.

THE BOTANICAL DEPARTMENT OF THE BRITISH MUSEUM.—Mr. J. J. Bennett, the Curator, has just issued his annual report for 1869. The principal business done in the department during the year has been:—The re-arrangement of a portion of the presses of the general herbarium; the re-arrangement of certain orders of *Apetalæ* and *Endogens*, and of the *Lichens*, both British and foreign, with numerous additions to each; the selection of a very large number of specimens from the herbarium of the late Mr. M. B. Ward, and from the collection of Abyssinian plants sent by Dr. Schimper through the Foreign Office; the naming, arranging, and laying into the general herbarium of Berlandier's Mexican collection, of Linden's collection from New Granada, Tate's from Nicaragua, Coulter's from California, Sartwell's *Carices* of North America, Wright's collections from the Neigherry Hills and from India generally, Jameson's from the Andes of Quito, *Orchidææ* from different countries, Ferns from the islands of the South Pacific, and of a large number of miscellaneous specimens of various families and from different countries; the examination and arrangement of the recent and fossil *Coniferæ* and *Cycadææ*; and of Mr. Brown's collection of fossil woods; the arrangement and incorporation in the general herbarium of a large number of European plants; the re-arrangement of various portions of the British herbarium, and of the collection of fruits and seeds; and the re-arrangement of various parts of the collection contained in the Exhibition Rooms, and especially of the cases containing *Coniferæ* and *Cactææ*, with large additions. The most important additions to the collection during the year have been:—Upwards of 1000 European plants from the collection of Dr. Keston and the late Mr. N. B. Ward; 900

plants of Ingermannland; 300 from Sicily; 200 European Fungi; 200 Italian Cryptogams; 3000 plants of Abyssinia, collected by Dr. Schimper; more than 3000 plants of South Africa, from Mr. Ward's collection; upwards of 500 from Madeira, collected by Lemann and others; nearly 1000 from the mountains of Altai; 1000 from India, collected by Dr. Wright; 400 from Malacca, collected by Griffith; 100 from the Feejee Islands, collected by Harvey; 1000 from North America; 400 Fungi of South Carolina; 300 plants from Nicaragua, collected by Tate; 700 from the Andes of Quito; a fine set of Pine cones from California; numerous specimens of plants and fruits, chiefly from Africa. The number of visits paid to the herbarium during the year for purposes of scientific research was 974.—(Nature.)

PROLIFIC STANDARD APRICOT TREE.

MR. RIVERS, of Sawbridgeworth, has obliged us by the following for publication:—"Knowing you take an interest in all kinds of trees, I write a few lines to give you an account of a standard Apricot of the Breda kind that I believe I had from you rather more than twenty years since, and which, if you think it out of the ordinary way, you can make known to the gardening world. I give you my word that I state no more than facts; anyone is welcome to see the tree with the crop now on it. Last year it bore the worst crop I have ever known, there being barely one dozen fruit. Three or four years since it produced rather over two bushels; this year I estimate the crop to be at least three bushels. The quality is excellent for preserving or culinary purposes. It is growing on a lawn not protected by anything. The site was, in my recollection, an Asparagus bed. The tree has a very handsome head, as large as that of a good-sized Apple tree. It is still in a growing state, and not nearly the size it probably will attain.—ANTHONY BURN, *Whitcombe Court, Gloucester.*"

[The tree is about 6 feet high, its stem 2 feet 3 inches in circumference, and the branches overshadow a circle rather more than 31 feet in diameter.—EDS.]

NOTES OF A HORTICULTURAL VISIT TO CALIFORNIA.

(By Marshall P. Wilder, Charles Downing, George Ellwanger, and P. Barry.)

Quality of Californian Fruits.—As a general rule, the fruits of California are superior to ours in size and beauty, but rather inferior in flavour. To this there are some exceptions. We think that the Cherries, Apricots, as well as early Pears and Apples, are as fine as can be produced in any country. The want of flavour is in many cases owing to the unripe condition of the fruit, premature picking, and improper ripening. The early fruits, not being of overgrown size, are generally of better quality than those of autumn; yet we are unable to say how far the want of flavour in these may be owing to improper treatment.

When we arrived in San Francisco the Apricot was very abundant and beautiful, as it was during nearly the whole period of our visit, but we were told the fruit were insipid. On taking some to our rooms and getting them fully ripe they were delicious, equal to any we ever tasted. Fruits on the market stalls are seldom fit to be eaten.

In the case of Strawberries, the best varieties, it seems, have not yet been adopted by the market growers. With the exception of the Currant, none of the small fruits seem to be as good as ours.

The Grapes grown are almost exclusively what we call foreign varieties. The Mission Grape, so called, is a foreign Grape, though improperly called California. Wild native Grapes abound in all the wooded parts of the State, but they are very different in character from the Mission. The practice is, among growers, to speak of the Mission as not being a foreign Grape. American Grapes have been tested in a few cases, but, as far as we could ascertain, with unfavourable results. We do not, however, regard the few experiments we heard of as conclusive, and think it quite probable that our Clinton, or some of its class, might be employed successfully to make a lighter wine than any they now make, and which is so much needed to take the place of imported claret now in general use.

Garden Vegetables.—The supply of culinary vegetables, as seen in the markets of San Francisco and other cities, is very abundant and of excellent quality. What surprises visitors

from the east is to find such articles as Celery in the market all summer. Crop after crop can be obtained in varied succession, so that you may find anything you desire at any season. Asparagus is cut from February to June. One grower informed us he had six acres. The product was about 5 tons to the acre, and contracted at 9 cents per lb. The size to which vegetables attain is almost incredible. We were told of Pumpkins weighing 250 lbs.; Squashes, 150 lbs.; Beets, 200 lbs.; Carrots, 30 lbs., &c. It is easy to understand how these results are obtained in a climate where growth never ceases. The mean temperature of the coldest month, December, at San Francisco, is said to be 55°. In the interior it is probably lower.

Ornamental Trees and Plants.—On arriving in California we were at once struck with the character of the trees and plants which we saw in the gardens, public streets, &c.

Instead of the Elms, Maples, &c., which prevail at the east, we saw the Australian Acacias and Eucalyptus, and the Mexican Pine, insignis, and Monterey Cypress, *Cupressus macrocarpa*. These are everywhere planted as the common trees. Nurserymen informed us that the first trees asked for, and in many cases the only ones asked for, by persons beginning to improve their city or suburban lots, are the Eucalyptus, Acacias, *Pinus insignis*, and *Cupressus macrocarpa*. The reason for this is, that these trees grow rapidly, transplant easily, and are adapted to the climate. We were told that the *Pinus insignis* is so easily transplanted that if the roots but touch the ground it will grow. The Eucalyptus and Acacias grow there as Willows do with us. In the grounds of Mr. William Patterson, a nurseryman of San Francisco, we saw Eucalyptus globulus, called the Blue Gum, six years old, which was 50 feet in height, and 5 feet in circumference of stem. A *Pinus insignis* of the same age was 40 feet high.

The *Cupressus macrocarpa* is more prevalent than any other tree that is planted for ornament either in city or country. We have even seen it employed as a street tree, pruned-up 6 or 8 feet, and the heads shorn into sugar-loaf form. The Acacias are frequently used in the same way, and although stiff and formal they look very well. The Cypress retains all through the long dry summer a charming verdure, when not stained by dust, as it often is in the streets. The Eucalyptus grows so rapidly that it is being planted for wood. We saw an account of one plantation of fifty acres planted 8 feet by 8 feet, for timber. There is ample scope for plantations of this kind.

In Mr. Patterson's grounds, already referred to, we noted a hedge of *Acacia lophantha*, 25 feet high and 4 feet through; a *Fuchsia* hedge, 10 feet high, the stems of the plants as thick as a man's arm; a hedge of *Veronica Lindleyana*, 10 feet high; beautiful specimens of *Araucaria imbricata* and *Cookii*, 10 feet high; fine trees of the *Guava* in blossom—the fruit ripens there in September; also the Camphor tree, and many other species we are not accustomed to see in the open ground.

Here we saw a superb show of Roses; the best we saw in the State, we think. *Eliée Sauvage*, Tea, was named as the most valuable for a constant supply of cut flowers.—(Moore's *Rural New-Yorker*.)

THE AMATEUR GARDENER.

(CHAPTERS NOT IN WALTON.)

No. 5.

SYLVIA.—I cannot tell you, Clericus, how much I am often interested in watching the minute insects which fall upon the pages of my book as I sit beneath the shade of yonder spreading *Acacia* on a bright summer's day. First, perhaps, the merest speck of a spider spins its thin cobweb from an overhanging branch, till in graceful undulations it alights gently upon the printed page, followed, probably, by a fly of such diminutive organisation that it almost requires a microscope to distinguish its ganzy wings which give it its motive power; anon a small green caterpillar descends from its ambitious position overhead, weaving its own coil of silken cord, by which it descends with an occasional spurt, as though it summoned up all its strength to effect its downward progress, and render its eventual fall as gentle as possible.

CLERICUS.—Yes, and each of those tiny insects must have the physical organisation of a larger being to enable it to effect its voluntary motion. Truly God's power may be seen as much in the ant as in the elephant, in the mite as in the whale.

HORTATOR.—How wonderful is the instinct which guides such minute beings!

CLERICUS.—Instinct! What a door of thought is thrown open at the mere mention of that mysterious word! What is the line of demarcation which separates instinct from reason? This is a barrier that the keenest philosophy has never been able to burst, nor the madness of atheism ever been able to explain.

CIVIS.—And then, too, what wonderful mechanism!

CLERICUS.—Yes. Paley says that out of the millions of designs which meet the inquiring eye of the natural philosopher, every one has a benevolent intent.

CIVIS.—Pray tell me, my good master, what is the name of yonder dark evergreen, which has such a stately growth, and which you seem to have banished as far as possible from the precincts of your villa?

HORTATOR.—That is *Wellingtonia gigantea*, a native of California, which has but lately (comparatively) been naturalised in Europe; and it is planted so far away because in course of years it might, probably, grow so large as to compel its being cut down if it grew nearer to the dwelling-house. In its own country specimens have been found fully 350 feet in height; and though in this climate it will probably never attain such a prodigious size as that, yet the rapidity of its growth in England gives fair warning that even here it will eventually assume gigantic proportions. But I am glad that you have drawn my attention to it, my good scholar, because it leads me to give you a word of warning, to be careful not to plant your evergreens, especially specimen plants, too closely in your garden in your projected new villa—there cannot be a greater mistake.

CIVIS.—But how miserably unclothed and bare a new garden looks when only small bushes are planted here and there.

HORTATOR.—Yes, that is the bait which leads so many, even among good gardeners, to fall into the trap of planting shrubs too closely; they are anxious to give a finished look at once to the grounds, forgetting that in a few years evergreens which would have proved splendid specimen plants will be dwarfed or spindled. Another very common error which amateurs are apt to fall into, and from exactly the same reason, is that of procuring large handsome plants instead of small ones, being ignorant of the fact that it is always the safer policy to plant younger plants, as they soon outstrip the elder, and shame their giant brethren by their healthy and luxuriant growth, while the Goliaths look wan and miserable, and often die altogether from a wasting consumption, to the heavy pecuniary loss of the amateur, for large plants are always expensive, and never satisfactory.

CIVIS.—Thank you sincerely for your hints. Is there anything else which appears necessary to the success of planting shrubs?

HORTATOR.—Yes, the careful preparation of the ground; be sure that it be deeply dug. I have frequently turned my eyes away in disgust when I have seen mere holes made, and shrubs thrust in without any further preparation of the soil, which should be enriched with thoroughly decomposed manure, when it is what the gardeners call "double-dug."

CIVIS.—You would not, I suppose, my dear master, Hortator, confine the planting in the pleasure-land entirely to evergreens?

HORTATOR.—Certainly not. A judicious planting of the finest deciduous trees is absolutely necessary to the better development of the Coniferae, &c. I once paid a visit to the celebrated gardens of evergreens at Elvaston Castle, near Derby, and I cannot describe the depressing effect which those acres of unbroken green had upon the spirit; for although the trees and shrubs were of the choicest description, and for the most part judiciously planted, yet the *tout ensemble* was perfectly funereal, and one seemed to expect a tablet "in memoriam" at every step one took; and it by accident the eye fell upon a bright flower, it was like a gleam of sunshine through a thundercloud.

CLERICUS.—Tell me, Hortator, did you ever see the splendid Purple Beeches in the gardens of the Earl of Stamford at Enville, in Staffordshire?

HORTATOR.—Never; but of their beauty I have often heard.

CLERICUS.—They are, indeed, worth travelling many miles to see when in their early summer beauty, when their regal robes of purple sweep the velvet lawns of those superb gardens, and seem conscious of the dignity which their august presence adds to that fairyland.

HORTATOR.—Should you, Civis, wish to learn much of forest trees, I would recommend you to study good John Evelyn's "Sylva;" and should you become much interested in him and his admirable diary, I would advise you to pay a visit to Wotton, in Surrey, the residence which that good man de-

scribes with so much feeling, and which, by kind permission of the present proprietor, Mr. Evelyn, a descendant of the celebrated writer, is open to the public on a Saturday. I can assure you, you would thank me for my advice.—HORTATOR.

FUNGUS EATING.

If we were to search the wide world I do not think that it would be possible to find a nation more prejudiced than ourselves. We boast of our enlightenment and the liberality of our views; but, when we come to the practical, it takes an immense deal of leverage to move us out of our beaten track; and, even in the common habits of our lives, we go on to the end of the chapter as though there was but one way of doing things.

In the little matters of eating and drinking we are perfect slaves to our cooks; and whether it arises from indolence, timidity, or ignorance, the result is the same—that few of us dare try experiments; whereby a great quantity of palatable food remains unknown and uneeded. This is particularly the case with the class of comestibles which forms the subject of my paper—viz., that of the Fungus; the true knowledge and appreciation of which would keep starvation from many a poor man's table (at least during three months in the year), and give the gourmand an additional luxury wherewith to tickle his palate. The apathy, ridicule, or disgust with which a serious proposal to cook and eat Fungi is received, is the more extraordinary because so much has been said and written about them; therefore it cannot be altogether from ignorance of the subject. Dr. Badham, Messrs. Cooke, Worthington Smith, Berkeley, and others have expatiated well and fully on the whole tribe of Mushrooms and Fungi; and, even for those who cannot screw up their courage to the crucial test of eating them, the works of these authorities are full of interest. More recently, too, the great Fungus question has been examined in the most practical manner by the members of a Natural History Society in the West of England, called the Woolhope Club, which has its head-quarters at Hereford, and embraces in its scientific investigations all the district between Shropshire and the Bristol Channel. Geology and botany are the main studies of this Society, but lately that of mycology (the study of Fungi) has been added, and a most useful and important one it is. One day in each autumn is devoted to a Fungus hunt through the prolific woods of Herefordshire, and the numbers that are gathered by this enthusiastic band are something enormous. The labours of the day are closed by a dinner, at which the main dishes are composed of the spoils of the chase, dressed in the most epicurean fashion, and with the most appetising (Fungus) sauces; and as I have myself assisted at these Apician banquets, I can vouch for the delicacy of the viands, and the absurdity which we daily commit of turning up our noses at the good things with which Nature has supplied us. But the Woolhope Club does more than eat and talk, for it publishes (though only privately) an annual volume of its transactions, including a description of the Fungi of the county, and the best modes of cooking them. These descriptions, and the illustrations which accompany them, are mainly due to the energy and experience of Dr. Bull, of Hereford, who has been the chief instrument in making the Woolhope Club a Fungus-eating community, and who rivals Soyer himself in his ingenuity in discovering new ways of cooking his favourite food.

Seriously speaking, however, I consider the endeavour to make the public understand the value of the Fungus to the nation so very important, that I shall draw largely upon the Woolhope experiences, as well as those of other writers, in the hope that the readers of the "Food Journal" will really try experiments for themselves. With the uninitiated in such matters there is, not unnaturally, a nervous reluctance in taking the first plunge; for, to the minds of most people, a Toadstool is only another word for rank poison, while a Puff-ball suggests horrible tortures by inordinate swelling, until the wretched victim bursts. This, I remember was one of the warnings in early life, not to meddle with suspicious Mushrooms. But, although there is some grounds for distrust (as there is in most other things), a little inquiry will show how fearfully the danger is exaggerated. The Rev. M. Berkeley gives us a list of 2380 different kinds of British Fungi, and even then does not include those which require a microscope to distinguish their peculiar characters. Out of this large number he ranks ten only as poisonous, and six as doubtful. He does not imply by this that of all the 2380 every one is eatable—for

this is very far from being the case—but simply that they are not poisonous; and that is the first and the greatest point which we have to combat. It is unfortunately the case that some of the most poisonous are the most common; for, as Dr. Bull observes, "There is scarcely a field, and, perhaps, not a single wood, in the country that does not abound with several varieties of the *Coprius*, the *Agaricus fascicularis*, the beautifully coloured *Riz-sula emetica*, and several others. But, since they are so abundant, it is peculiarly our province to encourage the study of mycology; and thus lessen the prejudice existing against them all, by clearly showing the means of distinguishing which are good and which are bad. This is a matter of some difficulty, for the scientific differences are too minute for ready distinction. We cannot be guided by the place they grow in; nor can we eat after slugs, as we do after wasps and birds with fruit, for slugs seem to enjoy the most poisonous kinds. Colour gives no distinction, nor is the smell or taste of the *Fungus* an infallible guide. It is freely acknowledged, therefore, that there are poisonous Mushrooms, and that, unfortunately, they are exceedingly common; but this is surely no argument for neglecting the far greater proportion of what may be made wholesome food. We might, on this ground, refuse to eat Potatoes, because that plant belongs to a family containing virulent poisons. Parsley, too, which is the most familiar garnish that we have, is not regarded with suspicion because the Fool's Parsley, which grows in many gardens nearly as freely, is poisonous. We eat Horseradish without thinking twice about it, although a year seldom passes without somebody being poisoned by accompanying their roast beef with scraped Aconite root, which is so like Horseradish that it requires a little care to distinguish between the two.

The question, therefore, resolves itself into this, that—whether it be Horseradish, Parsley, or Fungi—everybody, whether of high or low degree, ought to have that instruction in common things which should make it impossible for such mistakes to happen. While in our public schools we pretend to give instruction in chemistry and physics, it is inconsistent that we should ignore the study of simple geology and botany, the knowledge of which in strange countries is of incalculable importance; and the value of such elementary knowledge in schools of a lower class can scarcely be overrated. "A little knowledge is a dangerous thing," is a proverb that is often quoted by well-meaning people as a warning against this sort of instruction, as tending to make the recipients thereof smatterers, conceited, and presumptuous; but surely to teach a village child what Fungus he may gather for the cottage dinner without danger of being poisoned, is as useful knowledge as the height of the Himalayas or the date of the battle of Navarino. I am aware that there are plenty of facilities for this teaching in the way of cheap illustrations, such as those by Mr. W. G. Smith; but I cannot find that such teaching is anywhere made compulsory, or indeed is adopted at all, except in isolated cases.

Foreigners are far before us in appreciating the value of the Fungus as a food supply, and notably in France and Italy; although, with a due regard to the public safety, Fungi are allowed to be sold only when passed by the inspectors of food; with this regulation we certainly should not quarrel. Mr. Story, in his interesting work "*Roba di Roma*," tells us that one of the most common articles of sale are baskets of Mushrooms. "There are the grey *porcini*, the foliated *alberetti*, and the orange-hued *ovole*; some of the latter of enormous size, big enough to shelter a thousand fairies under their smooth and painted dome. In each of them is a cleft stick, bearing a card from the inspector of the market, granting permission to sell them; for Mushrooms have proved fatal to so many Cardinals, to say nothing of Popes and other people, that they are naturally looked upon with suspicion, and must be all officially examined to prevent accidents. The Italians are braver than we are in the matter of eating; and many a Fungus which we christen with the foul name of Toadstool, and ignominiously exile from our tables, is here baptised with the Christian appellation of Mushroom, and is eagerly sought after as one of the cheapest and most delicious of vegetables." In Milan, too, the *porcini*, which in English botanical phrase is the *Boletus edulis*; the *ovole*, the equivalent of the *Agaricus cæsareus*; with some few more, are openly sold under inspection. I will conclude this article with a quotation from "The Esculent Fungues of England," by Dr. Badham, one of the most persevering inquirers, and as audacious an experimenter as this country has ever produced. Describing his rambles in 1847 he says, "I have seen this autumn whole hundredweights of rich wholesome

dial rotting under the trees; woods teeming with food, and not one hand to gather it; and this, perhaps, in the midst of Potato blight, poverty, and all manner of privations, and public prayers against famine. I have indeed grieved, when I reflected on the straitened condition of the lower orders, to see unused pounds innumerable of extempore beefsteaks growing on our Oaks in the shape of *Fistulina hepatica*, with *Agaricus fuscipes* to pickle, in clusters under them."

Making allowances for a certain amount of enthusiasm, the question is certainly sufficiently interesting to urge us to do our best towards introducing this new food, at present wasted; not only by learning to distinguish the good from the bad, but by practically making the trial at our own tables. For it must be remembered that it is all nonsense preaching to the poor to try this and that, unless the rich do it themselves; for the former are not only more ignorant, but ten times more prejudiced, and, in many cases, the facility of getting them for nothing would be rather a hindrance than an inducement to make the experiment.

Still, if a demand should arise for Fungi, and the poor were to find that they were saleable articles, they would very soon begin to try for themselves what they were like; and in this way, with the most ordinary teaching and care, we might largely supplement the national larder.—PHILLIPS DEVAN.—(*Food Journal*.)

NOTES AND GLEANINGS.

A custom prevails at Easingwold in Yorkshire which we never met with anywhere else. Having occasion lately to visit that now-deserted town, we observed in the churchyard plates and dishes, containing gathered flowers in water, placed on the graves. This, we were informed, was done by the relations of the deceased. Sheep were grazing within the bounds, and not infrequently ate up the flowers and broke the plates, but these were, notwithstanding, constantly renewed. Our companion was unable to inform us of the origin or object of this practice, and merely remarked that it was an old custom.

— Two of the best MELONS we have met with this season are the VICTORY OF BATH, grown by Mr. Gilbert, gardener to the Marquis of Exeter, at Burghley; and the GOLDEN GEM, raised by and cultivated by Mr. Cox, gardener to Earl Beauchamp, at Madresfield Court. The former is a green flesh and the latter a white flesh, and both are of very superior excellence. Their size is large, and they are finely and beautifully netted.

— On a visit we lately made to Madresfield Court, Mr. Cox, who, by the way, is the fortunate raiser of that exquisite Grape the Madresfield Court Muscat, showed us the superiority of the fruit of VICTORIA NECTARINE grown against a wall in the open air to that grown under glass in a Peach house. That produced in the open air is very dark-coloured, and with a very rich and piquant flavour, while that grown under glass is much paler and comparatively flat, being far less rich. In either case the fruit was quite sound, and showed no disposition to crack, as its parent the Stanwick is so liable to do. In all situations where Nectarines can be grown successfully, we would recommend planters to make use of the Victoria.

— A CORRESPONDENT writes—"Yesterday I went to Eastnor Castle and saw the MISTLETOE ON THE OAK. This was the first time that I had ocular confirmation of what I had heard of. There are four large bunches near the top of the tree. This is the only example that is known in the Eastnor large Oak woods." Another correspondent, "VEVEY," says, "I noticed that you mention the few cases in which the Mistletoe has been found growing on the Oak. I have seen it more than once growing on that tree in the Canton of Vaud, Switzerland. I have also seen it on the common Norwegian Fir."

PROPOSED BOILER.

As an amateur gardener on a small scale, I have been much interested during the last year or two in the notices of various boilers and hot-water apparatus which have appeared in the Journal and elsewhere, and in the remarks which have been made on conduction, convection, &c.; also in the question as to the economy of flues or pipes for small houses, the result being the invention of a boiler which in simplicity, efficiency, economy of fuel, facility of setting and management, may be advantageously compared with any other. Having gone to

have heard of and seen some wonderful boilers, but somehow the wonderful soon becomes the rather common and everyday affair. That your boiler is a good one and easily managed we do not doubt. It is just the old upright cylinder boiler with these little differences: The fireplace on which it is placed is rather larger than usual; the top of the boiler is nearly double the width of the base, spreading regularly out to that width. The upright cylinder inside is of the usual regular shape, but that is appropriated almost entirely to the holding of fuel, which drops down as it is consumed, the heated air, it is true, passing partly through the fuel; but the chief heat from the fire passes directly from it through flues round the sides of the boiler, meeting over the top, and thence into the chimney. We have no doubt that by filling this cylinder with fuel the fire will last a long time, if you moderate the draught at the ash-pit-door. We believe that when fairly set going you will have little smoke, as the fuel will be well heated and carbonised before dropping into the fireplace, but with these advantages there is this disadvantage, that there is but a small part of the boiler exposed to the direct action of the red-hot fuel in the fireplace.

We should be very sorry to damp the aspirations of anyone, and especially an amateur, but having registered your invention we would let well alone; and if you asked our advice, it would be not to waste money on a patent. In your plan there is nothing new. For years back we have had sections of boilers sent to us, some as simple, and others much more complex than yours, and having the peculiarity of making the inside of the cylinder chiefly a fuel-box, so that you might have trouble enough with your patent if ever you should want to protect it. As a warning we may mention two facts—First, in a celebrated nursery we lately saw standing a substantial double saddle-back boiler, invented by one of the firm, and which had answered very well with them, yet, notwithstanding their influence, they have not yet sold enough of them to pay the first cost of moulding and casting. The second fact is, that some of the greatest gardeners in the country, after trying all kinds of boilers, are actually falling back on the common saddle-backs, and depending chiefly on the direct action of the fire, and regulating draught by the ash-pit-door and the damper. Provided a boiler is well set, a first-rate stoker will well make almost any boiler the best for a continuance.]

WORK FOR THE WEEK.

KITCHEN GARDEN.

CONTINUE to destroy weeds wherever they appear; clear away all decaying leaves from Broccoli and Brussels Sprouts, and have them or any decaying vegetable matter, at once trenched into unoccupied ground; still, the extent of unoccupied ground in a well-managed kitchen garden ought at this season to be very small. Prepare a quarter of ground for the main crop of Cabbages for next May, June, and July. Let it be thoroughly manured and trenched, as they will have to remain perhaps twelve months in the same spot, for if well managed they will produce after cutting an abundant crop of greens of the Colewort character. If ground and plants be to spare, a great quantity of the Early York should be planted out in well-manured beds or borders at about 6 inches apart; these will be "in cut" before the early Cabbage comes in, perhaps by the end of March. The Cauliflowers sown in August will be getting gross; they should be removed forthwith. Some persons pot them, and doing so is an excellent plan for the earliest lot. They may be kept thus in a cold frame or pit until the beginning of February, when they may be planted under hand-glasses. Those for succession crops if growing too strong may be pulled up, thrown on the ground for half an hour to check the fibres, and then be planted out in poor soil where they are to remain. To prevent the attacks of slugs on young Cauliflower and Lettuce plants, mix soot and lime in equal quantities, and dust them over with this once or twice weekly. We must now expect frost very soon, and ought to prepare accordingly. Lettuce, for instance, just coming into use may be lifted with balls and placed in frames. Look over Onions that have been stored, and remove any that are beginning to decay. Make the last out-door sowing of Radishes, which, if the winter do not set in early, may prove useful. Let the latest-sown Turnips have a thorough thinning and weeding. In late situations where Tomatoes are just ripening let them be gathered or ripened-off in the houses, as the least frost is fatal to them.

FRUIT GARDEN.

If wet weather set in let the Strawberry plants in pots be

protected either by turning the pots on their sides or by placing them in cold frames, but in either case so that worms may be excluded. Continue to collect late varieties of Pears and Apples. Walnuts are also quite fit to gather. Attend to Apples in the fruit room as before directed.

FLOWER GARDEN.

The time is at hand for alterations and the planting of choice shrubs. Where extensive alterations are contemplated, more especially in planting flowers, observations should be made before the flowers lose their character and the trees and shrubs are stripped of their foliage. Cuttings should be carefully looked over to see that nothing has been omitted, and that a sufficient quantity of everything is in a promising state for making good plants before winter. It should be borne in mind that plants which are at all difficult to winter if rooted after this time may be considerably thinned before spring, and also that they will not be sufficiently strong to furnish cuttings for spring propagation; consequently a larger quantity should be provided than would have been necessary had the cuttings been put in six weeks ago. If there is a reserve stock of strong plants in pots, to have which is a safe practice where many bedding plants are required, and if there is proper convenience for growing them and propagating in spring, they will furnish a large number of cuttings next March, and become as good plants by turning-out time as cuttings put in now. In the case of such plants as Ageratum, Petunias, Heliotropes, and dwarf Lobelias it is useless wintering young stock, as they grow so freely in heat, and are so easily propagated from soft cuttings, that a few good-sized old plants, which require but little room or attention in winter, will furnish a very large quantity of plants by bedding-out time. Attend to the potting of cuttings sufficiently rooted, and give every after-attention to them in order to have them well established. Persevere with leaf-sweeping and other routine work.

GREENHOUSE AND CONSERVATORY.

Chrysanthemums intended for the decoration of these structures should be placed under cover at once and receive every attention. Regular watering is one of the most important matters, for if allowed to become dry, if only for a few hours, decay or yellowness immediately takes place in the under leaves. They will from this time enjoy liquid manure constantly, provided it is perfectly clear and weak. All suckers should be pulled away as they are formed. See to thorough staking here, and the extermination of all insects. Large specimens of the following make a fine figure at this period:—*Buddleia Lindleyana*, *Gesnera lateritia*, *Salvia patens*, *Begonia incornata*, *Phlox Drummondii*, *Ipomoea ficifolia* (trellis), *Thunbergias*, *Plumbagos*, *Justicias*, *Clerodendrons*, &c. Stocks and Mignonette sown a few weeks ago may now be transplanted, especially the Stocks. If any early bloom is desired, half a dozen plants may be put into a well-drained 5-inch pot. The last shift should now be given to forward *Cinerarias* intended to bloom this autumn and early in spring; use most liberal drainage, and put them under cover close to the glass, with a free circulation of air. *Tagetes lucida* is a good late-flowering plant; although of long standing, it is not so generally known as it deserves to be, and grown in pots it makes a good display in November, the flowers being a rich yellow. Tie *Azaleas* into form as soon as can be done, in order to give them a neat appearance. Look carefully after the watering of large hardwooded plants in pots, especially Heaths, which are soon injured by being either over or under-watered. Examine the specimens often and carefully, and when they are found to be dry water thoroughly, so as to moisten the whole of the ball; also look sharply after mildew on softwooded Heaths, and dust the plants with sulphur directly the enemy is perceived. Look carefully after red spider on Brassicas, *Chorozemas*, and anything else found to be liable to the pest. Red spider is easily got rid of by laying the affected plant on its side and well washing the under sides of the leaves with the engine, applying the water with as much force as the foliage will bear. Repot strong-growing *Pelargoniums*; plants fairly established after repotting can hardly be kept too cool. Keep tree Violets clear of their great enemy, red spider, by a liberal use of the syringe, and give them plenty of manure water, which will assist in keeping them in vigorous health. *Primulae* must also be carefully attended to, in order to encourage them to make rapid growth.

STOVE.

The stove, as well as other gardening structures, partakes in general of some re-arrangement at this period, when the

general cry is "House all tender plants;" while such is proceeding, let all plants that require it be properly staked where necessary, as well as freed from insects. Young stock of *Begonias* for winter flowering may still be shifted. Some of the bulbous tribes will now begin to waken from their dormant state, and some will speedily show blossom; these, when fairly started, if pot-bound, may receive a shift, using a compost of sandy loam and vegetable matter; a little bottom heat would be of service after this operation. Keep the atmospheric temperature moderate at this period, and give liberal ventilation. —W. KEANE.

DOINGS OF THE LAST WEEK.

SUCH a week of sunshine that but for slight frosty mornings and a few leaves falling from Chestnuts and Elms, in the flower garden we might imagine we were in the first days of August instead of approaching the end of September. Everything seems to betoken that the end of autumn is approaching, as from the dryness and heat of the summer all deciduous trees will lose their leaves earlier than usual. Many evergreens, too, suffered from the drought, and there could scarcely have been a more unpropitious season for trees and shrubs planted in spring; and where, owing to circumstances, no water could be given them, many not convinced before, will be satisfied now of the importance of early autumn planting when it can be attended to. Last autumn in this district such a thing was impossible, as the plants were far too dry to be raised, and the ground when turned up for planting was little better than so much dust. Without heavy rains the soil will be little better this season, but where the rains have been plentiful, or if they come before the weather is much colder, there will be a most favourable time for early autumn planting, as the summer's growth will be early matured, and the ground will be warmer than usual to encourage fresh rooting.

KITCHEN GARDEN.

It is always well to have enough, and it is more pleasant to pull up what may not be wanted than to find the want of anything. Even small plants of *Endive* and *Lettuce* planted out now in spare places, as among bush fruit, may stand the winter well, and if many fail it will only be the trouble of planting. Winter and spring Lettuces are considered great delicacies by some, and had we room we would now take up with balls a number of plants 3 or 4 inches high, and plant them where they could have the protection of glass in winter. It is on the whole waste of space to plant them too thickly; they should not be less than 12 or 15 inches apart when we wish them to grow and form fine individual specimens. It is enough to make one envious to see whole ranges of cold pits thus filled with young Lettuces, the lights all off, but ready to be put on at the first approach of frost or of heavy rains, but plenty of air given in the latter case. The treatment of such plants ought to be quite different from that of full-grown Lettuces and *Endive* taken up towards the end of next month, and which may be placed quite close together, in order to be used as wanted. Small plants turned out now in cool unheated orchard houses will come in very useful early in spring.

Cauliflowers.—We have strewn some charcoal dust and a little lime and soot among our young small *Cauliflower* plants, as they did not seem altogether right, and showed some signs of mildewing. These we shall prick out thickly in a bed in fresh light soil before transferring them to the hand-glasses or pots for the winter. Succession crops of *Cauliflower* for present and late autumn use we have been obliged to refresh with sewage water; they so hung their leaves in the bright days as to leave the heads, not quite full-grown, exposed to the fierce sun, which has a tendency to make them harder than they ought to be. All vegetables, to be good, should be used soon after they are cut. Many complaints are the consequence of allowing vegetables to remain for some time before cooking them. Even a *Cabbage* cut and taken to the pot is altogether different from a *Cabbage* cut and allowed to lie for a day or two. We have known thorough admirers of the *Cucumber* who would have known if their favourite kind was cut more than half an hour before it appeared at the table. When vegetables are cooked a little more time after cutting is of less consequence. No keeping treatment afterwards entirely makes up in flavour and crispness for cutting fresh and just when wanted.

Cabbages.—These are growing, if anything, too well, as, except *Coleworts*, we do not wish the early crops for next season to be too forward before winter, as there is then a greater likeli-

hood that they will bolt in the spring, instead of making fine heads. Caterpillars, so ruinous in many places, have troubled us but little; but when we thought we had got rid of clouds of fly by syringing, &c., we find it is coming again, though in but small patches, and the same remedy must be again applied. Small plants of *Cabbages* pricked out rather thickly now in poor soil will make much more serviceable plants for spring planting than if they had been left in the seed bed.

Forking and hoeing all ground amongst young growing crops will greatly promote free growth.

FRUIT GARDEN.

As soon as we have time we shall clear away all runners and litter from *Strawberry* plantations, merely pricking over with the points of a fork the surface soil between the rows, and mulching with rotten dung; better for the purpose, when they can be obtained, are fresh horse droppings, laid in a heap long enough to heat and destroy what vitality may be in the oats that have passed into the droppings. Even old Mushroom-bed dung is good for such a purpose, but nothing answers better than the droppings, though few can obtain them for such a purpose. When thus used the droppings need not be put on so thickly as rotten manure. Even a dressing of a couple of inches of manure becomes very thin before spring. We greatly prefer that all such manure as surface-dressing should just remain on the surface instead of being forked in, however slightly. The crowns of the plants should not be covered, but the manure may rise higher in the middle of the space between the rows. Those who put on such a dressing for the first time will be surprised how little there is left of it in spring. A slight clearing away of dead leaves in spring, with a little of the roughest of the mulching, will leave all neat.

New plantations of *Strawberry* plants may now be made, but if the plants are good, less importance attaches to the time of planting than to the condition of the ground, which ought to be well trenched, manured, and then partly solidified on the surface before planting. As in everything else, there is an advantage in early autumn planting, and if the plants are turned out of pots all the better, as they soon establish themselves in their fresh quarters, and may be expected to bear well in the following summer. Where, however, ground is scarce we can recommend the following plan. Take off the runners as soon as they show roots, prick them out in a bed made light and rich on the surface to the depth of 4 or 5 inches, by adding rotten dung, leaf mould, and some light sandy matter, and let the plants be from 6 to 8 inches apart. Shade a little at first, and when the young plants can take care of themselves give all the sun and heat possible, and waterings when needed. On ground heavily cropped until Christmas we trenched, dug, and re-dug until it was in a finely-pulverised rich condition by the end of February, and then we have lifted these plants with balls, and transferred them to the fine mellow soil, and had as good returns in June as if we had planted in the autumn. Many such schemes must be resorted to where the most has to be made of a little piece of ground. The labour is, doubtless, increased, but the ground is made to yield more.

Strawberry plants in pots for forcing need less watering now, as the aim, in the forwardest especially, should be to ripen the buds or crowns. We must try and give ours a little more room, as the large foliage—quite large enough—is too close together.

As the nights are becoming colder, it is as well to give any watering that may be required about 9 A.M., as the soil, if fresh watered, gets cool in a clear night. The same rule applies to all watering, just as in the hottest weather and the longest days it was advisable to water in the afternoon and evening. Such a system could not easily be carried out with the present stereotyped hours for gardening and agricultural labour, but often in hot weather one watering after 7 P.M. in July and August would do more good than two similar waterings early in the afternoon. Often the little water we use had to be given at any time, just when we could get it, but then we had to resort to modes to prevent its quick evaporation which would not have been needed if we could have given the same water when the sun was low, and twilight and night approaching, so that the plant should have little or no strain on its resources.

Hardy fruits, as Apples and Pears, have been much improved in their appearance during the past week, obtaining that rich colouring which nothing but a bright warm sun can give. Some of our readers were so alarmed by what the late gale did in throwing down many of their fruit, that they gathered most of what remained forthwith, they say now to the great

loss in colouring and such due ripening as insures good keeping. We are afraid that the gale in some cases was only the apparent cause of much fruit dropping prematurely. Many thus dropped would be found not quite sound, but beginning to decay at the core, owing to maggots, &c. In other cases, though we hope not numerous, the Apple, though seemingly perfectly sound outside, has the inside streaked with a fungoid disease, something like the Potato disease. Before cutting up the Apple nothing of this is to be seen. Such Apples, and those that have been a resting place for the maggots, will naturally drop before the sound ones are ripe. Those which are sound we should think would keep well, as if not quite so large they will be more perfectly matured; but such numbers having fallen from large trees, people are apt to say the fruit will not keep this season. Owing to this and the heavy crop, Apples in some places can hardly be disposed of at any price. If this weather continue we should not like to gather all our fruit for some weeks, if the dryness do not again force the birds to go to them for moist food. Flies and wasps are bad enough, but they are nothing to the larger birds, who soon demolish the sunny side of the best fruit, if left to take their own way.

ORNAMENTAL DEPARTMENT.

What a pity frost may be expected soon to come! With the exception of withered tree leaves, the fore-runners of what we may expect, the flower garden is still in its glory—so much so, that we are chary in taking the necessary number of cuttings, and have been obliged to decline supplying others. Circumstances quite alter cases. We hear of gardens almost dismantled already, the Geraniums taken up and given away, or potted and boxed for future use, and the ground being prepared for bulbs, spring-flowering annuals, &c. In private gardens where the family leave in August and September, and never return before the season is over, such a plan may be adopted to the benefit of all concerned; but we hardly see how it can be adopted where there is a resident family, and where the garden is required to look well up to the latest day possible. We have frequently had the flower garden finer and richer, but for the falling leaves, in the end of October than it has been in the end of June, or even July. In all cases where there are such remembrances, clearing the beds and borders in September is quite out of the question. When such beds are to be supplied with early bulbs as well, two plans may be adopted. First, pot the bulbs, to be planted afterwards in patches or in regular lines; or set the bulbs far enough apart on some rich compost, and cover them several inches deep, and then when the beds are cleared, dug, and pulverised, move the bulbs, and plant with balls, and they will do almost as well as if planted out early at once. The getting the beds in good order, just as in the case of the Strawberries referred to, makes up for earlier planting.

Greenhouse Plants.—The most tender should now be placed under cover, and even the hardiest should be so placed as to be easily protected from heavy rains and early frosts. The roots in the case of frost will be in greater danger of injury than the branches. Camellias are apt to throw their buds, and Azaleas to drop their leaves, if the pots are much exposed to frost. All the Epacris tribe are more sensitive to cold than even the Cape Heaths; the former should be housed, and the latter, if in pits and frames, should be protected from heavy rains and sudden frosts. In tolerable weather the lights should be on at night, but air left on top and bottom. The free dews now might be rather much for them. We have noticed of late that some trees have thrown down quite a heavy shower in the clear mornings, making a puddle all round their base.

Propagating.—We lately said we liked to propagate all bedding plants without any artificial heat. In propagating Verbenas, &c., now, we like to give a little mild bottom heat. For instance, if we use an old Melon bed under a frame, we take out the soil and a portion of the top dung, turn over what is below, and add about a couple of barrowloads of fresh hot dung to each light, cover with a few inches of the old dung, and then surface with dry ashes. If we could have obtained enough of cuttings early we would not have taken them now, or given them heat.

From several letters we are sorry to find that we have not made some of the modes of propagating plain enough, as we are asked if we really think small cuttings of such subjects as Geraniums are as good as large ones? and again, Do we think a pot of cuttings as good in the spring as the same number potted off in the autumn? We clearly stated that where there

was a reserve ground, and large cuttings could be obtained without interfering with the flower garden, they would be the best, and if each were in a small pot it would be better still. But, then, if we cannot do the best we must do the next best. We use small cuttings, and keep them generally in cutting-boxes all the winter, because if we used the smallest pots we could not by any means house the number we required. We give Geraniums from 1½ to 2 inches each, and Verbenas, Heliotropes, &c., much less, and contrive to give them more room after the days lengthen in spring, but the great proportion of them are seldom honoured with a pot of any sort. Dry season and altogether, the plants have done so well that many will not believe that these large Geranium plants were small short slips 2 inches apart in boxes in the middle of September, 1869. These little plants, just nicely rooted before winter, generally do well in the following season, and grow vigorously as well as bloom profusely. Our Verbenas when they succeed well are cut over in spring, much as we would do Mustard and Cress, for cuttings, for though the plants struck so thickly in autumn answer well, the spring-struck cuttings succeed better in our estimation. Whoever, then, has room and convenience cannot err if he can pot and establish in pots all his bedding plants in the previous autumn. We wish, however, to show that there need be no despair if we can find the means of wintering a great many thickly set in pots or boxes. We have frequently alluded to the best mode of taking up and wintering old plants of Geraniums.—R. F.

TO CORRESPONDENTS.

* * * We request that no one will write privately to any of the correspondents of the "Journal of Horticulture, Cottage Gardener, and Country Gentleman." By doing so they are subjected to unjustifiable trouble and expense. All communications should therefore be addressed solely to *The Editors of the Journal of Horticulture, &c.*, 171, Fleet Street, London, E.C.

We also request that correspondents will not mix up on the same sheet questions relating to Gardening and those on Poultry and Bee subjects, if they expect to get them answered promptly and conveniently, but write them on separate communications. Also never to send more than two or three questions at once.

N.B.—Many questions must remain unanswered until next week.

NAMING FRUITS.—We have repeatedly requested our correspondents not to send more than about six specimens to be named, for to identify them accurately requires much consideration, and consequently time. Yet we have now before us three baskets containing respectively twenty-nine, twenty-three, and seventeen specimens. From them add all such numbers we can only take a fraction for naming, and it annoys us not to be able to do all we are asked to do by our correspondents.

CLEANING LINUM AND PHLOX SEEDS (T. E. M.).—The best plan we know is to lay them on a floor, beat with sticks, and when all the seeds are out to sift through a sieve to free them of the husks; finally winnow. The wind will answer very well for a purpose of this sort. Having spread a cloth, let the seeds and dust fall from a height of 3 or 4 feet, and the chaff will be taken off clear of the sound seeds by the wind. We do not know any seedsman who purchases small quantities of seeds collected by private individuals. Write to some seedsman, telling him what you have to dispose of.

GATHERING QUINCES (Idem).—When they part freely from the tree, as they will do at the beginning of next month, they should be gathered, and not only on a fine day, but, if possible, after continued fine weather.

WINTERING CARNATIONS IN THE OPEN GROUND (A. H.).—Your best plan will be to plant them out, if well-ripened layers, in moderately light soil in an open sheltered situation, affording them the protection of hoops and mats in very severe weather. Could you not pot them and winter them in a cold frame?

GYMNOGRAMMA CALOMELANOS WITH PARTLY GOLDEN PINNÆ (Hafford-uddyn).—This is the first instance that we have known of a silvered-powdered Gymnogramma having both silver and gold powder on the under side of the pinnæ. What makes it more remarkable is that some pinnæ should be wholly golden-powdered. It is likely you would obtain a golden Calomelanos by sowing the spores of the pinnæ of that colour, and no doubt many silver ones.

REPLANTING BOX EDGING (Thomas Marsh).—You may now take up and replant the Box as you propose. There is no fear of its not growing, providing you use rooted divisions or slips, and water at planting if the ground be dry. If the weather be moist the watering will, of course, not be necessary. You may remove the very straggling growths, but that should be done at the trimming before planting, and no after-cutting with the shears is needed, or, if there be, the edging is badly planted. It will grow quite as well now as planted in February.

REPLANTING TULIPS (Idem).—You may now take up the Tulips that have remained in the ground all the year, removing them with a ball if they have rooted, and replant at once; or during the time they are out of the ground they should be carefully shielded from the sun and wind. We cannot answer questions privately.

DESTROYING HORNETS' NEST (Subscriber).—The best plan would be to dip some strips of paper in melted stone brimstone, set light to them,

and place them in the hollow in the old Apple tree, closing the hole so as to confine the fumes. This, of course, will need to be done after twilight. You must close every hole, or, if that be impracticable, pour in some spirits of turpentine, and close the opening.

KING OF THE FUCHSIAS (J. G.).—It is not a free-blooming sort, but does not require treatment different from that of other kinds. Why grow it in the stove? A light airy greenhouse, with a slight shade from very bright sun, is the best place for it.

TENANT REMOVING (W. B. B.).—If you pull up, cut down, or otherwise injure any of the trees or shrubs, planted either by your father or yourself, you will act illegally. You are not a nurseryman. Your landlord cannot be made to pay for the trees and shrubs. You have no right to remove the flagstone if fixed to the walls. You may remove the Cucumber frames. You must consult your solicitor on the other questions.

PAINTING A PEACH HOUSE (J. X.).—There is no objection to green paint in point of colour for the outside woodwork of a Peach house, but it is not durable. That paint is found to answer best which is composed of the most lead; hence white paint is the best of all next to red (which is a very objectionable colour); but we think a pale stone colour preferable, as it does not show dirt so soon as white. That kind of glass known as crown, having a green hue, is preferable to the white sheet; but we are using 26-oz. sheet glass for the roofs of Peach houses, and glazing the fronts with $\frac{1}{4}$ -inch polished plate glass. For a fernery we are using $\frac{1}{2}$ -inch rough plate; whilst for a stove we have $\frac{1}{2}$ -inch rough plate ground on one side for the roof, and glaze the sides and ends with $\frac{1}{4}$ -inch polished plate. A ray of light is of three colours.

EARLY PEACH TREES (Amateur S.).—Your espaliers are no doubt in an orchard or other house, for in the open air we think the espalier a very uncertain means of growing Peach trees. Two of the earliest early Peaches are Early Beatrice and Early Rivers, both good, and to succeed them you may have Early York. They ought not to be removed until the leaves have begun to fall.

INDIAN SHOT (CANNA) TREATMENT (Idem).—The varieties of *Canna* are much employed for subtropical gardening. You do not say whether your plant is in a pot or planted out, but we presume it is a pot plant. In that case you will need to continue it in a greenhouse during the winter, watering up to December, but not excessively. If the foliage be kept fresh, that is sufficient. Until the middle of February keep the plant dry, then repot it, and encourage growth by an increase of moisture and warmth, and, if possible, with bottom heat. If wanted for planting out of doors in summer, harden the plant well off before turning it out at the end of May or beginning of June.

BOXES FOR HOLDING USEFUL MEASURES.—We have to warn our readers that the quotation we made at page 184 from the "English Mechanic," does not give correct dimensions. The Editor of that journal has since published the following:—"We obtained the above-mentioned paragraph from a journal called the 'American Artisan.' As it appeared to contain what is simply a matter of calculation, it did not undergo the usual editorial criticism. In future we shall hesitate before we insert any valuable tables found in our transatlantic contemporaries." We are obliged to a correspondent, "A. L.," for bringing the above to our notice. He adds:—"Subscribers will do well, therefore, to put a note of warning against reliance upon it in the margin of their copies. I give an instance of error. A pint really contains 34.659 cubic inches, plus a very small quantity, which may be disregarded. The table states that a box of 4 by 4 by $\frac{1}{2}$ " = 68 cubic inches, will contain a pint. So it will, and nearly another pint."

DESTROYING WOODLICE (L. E. G.).—The best plan of destroying them is to place a little hay loosely round the sides of the structures they infest, and in the morning pour boiling water down the walls a little above the hay. This, of course, kills all it touches, and repeated several times will entirely destroy them, though they will in time reappear. When this method cannot be adopted on account of the boiling water being likely to injure plants, your best plan will be to place a boiled Potato wrapped lightly in a little hay in a small flower-pot, and put the pot on its side where the woodlice are troublesome. This trap should be examined every morning, and the woodlice secreted in the hay shaken into boiling water. A number of traps of this kind, put down every night and examined in the morning, will soon thin their numbers.

PETUNIA SHOOTS DYING (Idem).—We cannot account for your Petunia dying back, but think it is owing to the flowering shoots being broken off. The plant will probably die back to the shoots at its base, to which we should cut down.

RABBITS ATTACKING WELLINGTONIA GIGANTEA (T. Wilson).—Although the Wellingtonia is not so much destroyed as many other trees by rabbits still it is subject to their attacks, and we have seen every twig, leader and all, eaten off a number of very promising young trees, the bark being also nibbled off, but the spongy bark of older trees they do not meddle with. Where rabbits and hares are numerous, we would not advise you to leave your specimen trees unprotected. We think a piece of galvanised wire-netting, 2 feet or 2 $\frac{1}{2}$ feet high, fixed to the inner side of the iron fence which protects the trees from the cattle, will be all that is wanted. This would admit air to the lower branches, and be altogether better than woodwork. The netting must be sunk an inch or two into the ground; or, what is better, if a board be first sunk in the ground, the edging of the netting might be fixed to it; but we do not recommend any deep digging near the Wellingtonia, as its roots are so near the surface. Be satisfied with merely inserting the netting an inch or two, and examine it occasionally in order to stop any attempts at burrowing under it. We are glad to hear you have so fine a tree so far north; it is well worth taking care of. It is unaccountable, but nevertheless true, that rabbits have a propensity to attack choice single specimens; where there are a number of plants of one kind the probability is they will all escape, whilst a single tree is sure to become a prey. In our own case we find nothing escapes their attacks excepting, perhaps, the common Elder, Box, and Rhododendron ponticum, and even the last-named is not always safe.

TORTOISE (Notice).—We are not aware that tortoises benefit a garden. They live upon Lettuce leaves, Sow-thistle, and other succulent vegetable produce. They should be taken in-doors during the winter, unless there are large heaps of leaves in which they can bury, for they are torpid throughout the winter.

PLANTING AN AVENUE (Violet).—Without knowing more of the size of the avenue, we could say little as to grouping it prettily. In an exposed

bleak place, Pinus Pinaster and austriaca would do well; and Deodars and Wellingtonias might be tried, but neither should be planted thickly. We have seen fine effects made in the sides of avenues, where, as in your case, Rhododendrons would not grow, by planting such Pines about 35 feet apart, and then clothing the ground with a carpet of Laurels kept cut every year.

LIST OF ROSES (M. B.).—I am asked to name twenty-four Roses "the best for exhibition in all colours, and that are hardy and free bloomers." I could diversify the colours more if I were allowed to name some Tea Roses; but as nothing is said about them, I shall only name one, Sombreuil, white, which is very hardy, a free and constant bloomer. Then have Charles Lefebvre, Marechal Niel, Senateur Vaisse, Souvenir de la Malmaison, Comtesse Océide de Chabrilant, La Ville de St. Denis, Pierre Notting, Alfred Colomb, Madame La Baronne de Rothschild, Madame Victor Verdier, Triumphe de Rennes, Madame Boll, Prince Camille de Rohan, Coline Forestier, Dr. Andry, Marguerite de St. Amand, Gloire de Dijon, Lady Suffolk, Marechal Vaillant, Madame Boutin, Jules Margottin, William Griffiths, John Hopper, and Mademoiselle Marie Raby. I add a surplus of good Roses—Gloire de Vitry, Duchesse de Cuyllus, Baron Gonnella, Lord Clyde, Leopold Premier, and Baron Adolphe de Rothschild. I name some of the best Tea Roses in delicate colours—Devoniensis, Souvenir d'Elise, Souvenir d'un Ami, Madame Willermoz, Madame Margottin, and Adam. The new Tea Rose, Marie Sisley, has just bloomed well, and is extra fine. The plant is small, and I can say nothing of its growth. Marechal Niel must have a wall. My best plants are on the front wall of my vineery. They are on the Manetti stock, and grow and bloom well. The best plant of it that I ever saw is on a low Briar on a vineery wall out of doors, at Mrs. Oliver's, at Child Okford. The blooms grown there were by far the finest that I ever saw—like large bells. It is a famous Rose for a hot town garden. If it is objected to, select Duchesse d'Orleans for light colour, or Lord Clyde for deep colour. All the Roses named are here on the Manetti, and do well. It is right to say, that although Alfred Colomb is one of the fullest and finest of the show Roses, it does not always in the fore part of the season bloom freely.—W. F. RADCLIFFE.

IVY-LEAVED GERANIUM (W. M.).—Your specimen is not one of the Ivy-leaved varieties.

GRAPES (W. G.).—The small Grape is the Royal Muscadine. The other we do not recognise; it is certainly not a Muscat. Send another bunch with one or two leaves.

MELON DE NAMUR PEAR (G. B.).—We do not know it.

PEARS FRUITING IRREGULARLY (C. W. H.).—Being able to secure blossom regularly throughout, one would suppose there should be fruit also. We believe your trees fail to fruit, excepting at the extremities of the branches, from a want of equalisation of forces. Better fruit spurs are produced at the points of the shoots, perhaps through their being better exposed, and thus better matured, &c. Young trees frequently bear only partially; when, however, they have filled their allotted space, and by carefully summer-pruning the young shoots the active forces of the tree are equally distributed throughout, you will find fruit produced quite regularly all over. Bending down the branches as you propose, we do not think would be of much service. We attach far more importance to the summer pinching and regulation of the leaves or lungs of the tree.

STORING FRUIT (R. J. S.).—The conditions most conducive for the preservation of fruit are a dry atmosphere and a cool equal temperature with darkness. Light hastens decay; so does a close, warm, damp atmosphere. It is well, then, to keep your fruit-room tolerably dark, cool, and airy. We would not be at the trouble, however, to barricade the windows to any inconvenient extent. We do not know where you can obtain a fountain like that referred to. The design was American.

GARDEN LOSSES IN FRANCE BY THE WAR (Edm.).—We have no statistical information on this subject, but we see that it is stated in the *Journal de l'Agriculture*, that the French farmers have lost more than £163,000,000. We deplore as much as you do the unnecessary and terrible contest, but our columns must not be opened to the subject. There would be no wars if the only gladiators were allowed to be monarchs and their ministers.

"O, if I were King of France,

Or, what's better, Pope of Rome,

There would be no fighting men abroad

Nor weeping maids at home.

All the world should be at peace,

Or, if kings must show their might,

I'd let those who make the quarrels

Be the only ones to fight."

SELECT CLEMATISSES (Q. Q.).—C. Jackmanni, which you know, is one of the best, and another of Mr. Jackman's raising—viz., Beauty of Surrey, pale blue, with smooth and stout petals, is fine. Lady Londesborough, raised by Mr. Noble, Bagshot, with pale lilac flowers, is large and showy, and so is Miss Bateman, white. These are four fine Clematises, but we do not think they would do for trellises in an exposed situation on a hill top. If planted against a trellis this autumn they would not require pruning next spring, nor would they flower to any great extent next season. A good rich light loam is the best for them. Probably the finest of the Clematises is Excelsior, double, bluish mauve, with a flame of brown along each petal; stamens white. To do well in cold situations they require an aspect between south-east and south-west. Where they require protection in winter they will do little good in summer, but for young plants a slight protection is good early in spring.

SPANISH AND ENGLISH IRISES (Idem).—Let them remain in the ground, and mulch it with well-rotted manure or leaf soil. From one year's growth they will not have spread so much as to need taking up and dividing; we like good clumps of them, not stragglers. To be seen to advantage, a mass is best.

SIRKIM RHODODENDRONS REPOTTING (An Old Subscriber).—The best time to repot them is in spring, just before they begin to grow. We would not cut in the plant of Dalhousie until spring, and then do not repot until it has made fresh growths 3 or 4 inches long.

LILIUM ACERATUM AND LANCEIFOLIUM TREATMENT (Idem).—Pot them now. Turn them out of the pots, remove the drainage, all the old soil that comes away freely, and all the offsets not of a flowering size. Pot the bulbs in well-drained pots, using a compost of one-half light turfy loam, one-fourth old cow dung or leaf soil, and one-fourth sandy fibrous peat, with a free admixture of sharp sand. Allow the roots a moderate

amount of pot-room, and pot so that the crowns may be barely covered with soil. Allow for about an inch of top-dressing to be applied in spring when the shoots are about 6 inches high, doubling the quantity of cow dung along with the loam and peat named for potting in. Winter the bulbs in a cold frame, protecting them from frost. They will need but little water during the winter; merely keep the soil moist. When they are growing freely water copiously, but avoid saturating and souring the soil by frequent heavy waterings; and if you can afford a cold pit or other cool place, with plenty of light and air, they will grow strongly and flower finely. The main point is to give encouragement when they are starting and up to full growth, and do not disturb the roots by frequent and needless repotting and shifting. Keep the plants free from insects.

EDGING TILES (A. W.).—There are no better tiles for edgings to walks or borders than those made of fire clay. You may obtain particulars from those who advertise in our pages.

TRANSPLANTING EVERGREENS (S. H. S.).—When removed there ought to be good balls with all evergreens of considerable size. We would advise planting now, only the ground is so very dry that it would be difficult to take the plants up with a ball, and they would need to be well watered after planting. If you have rain with a ball, that is quite as good as digging round each plant and leaving it a year. No good is done by digging round the plants in autumn, and then waiting until spring in the hope of a ball, for at that time they will be in little or no better state than when they were dug round. A year is necessary to secure roots near the stem. If you do not remove them this autumn, do not remove them before March. Early in autumn and late in spring are the best times for transplanting evergreens; the autumn is to be preferred if the weather is moist and mild.

VARIOUS (Idem).—It is not too late to put in cuttings in boxes, placing them out of doors in a warm situation, but protect them from frost, and house them early in November. The proper time to put in cuttings of *Calceolarias* is from the present time until frost occur, inserting them in a cold frame in a dry, sheltered situation, having about 6 inches of soil, and over that an inch of sand. The cuttings may be put in about 14 inch apart, and should have a good watering; afterwards they need abundance of air and protection from frost. There are two ways of forcing *Rhubarb*, one by placing boxes or pots over the crowns, so as to enclose them, and then covering up with stable litter in a high state of fermentation, to cause the speedy growth of the *Rhubarb*. The other plan is to take up the roots and place them in a house or shed having a temperature of 50° to 60°, just covering them with soil. You may practise either of the modes named from the middle of November to March. *Salvia patens* is freely propagated by divisions of the roots; but both cuttings and seeds answer very well. The insect on your *Fernis* is not a thrips, but a male aphid; both are destroyed by fumigation with tobacco. The insect is probably brown scale. The best remedy is to cut off the fronds most infested and burn them, and to pick off the soft insects with the point of a knife—a tedious but safe mode of clearance. Insect-destroying compounds will also rid you of them. The best way to utilise a piece of ground for growing vegetables for a family, is to trench and manure it well, and plant it with the kinds of vegetables required. The piece of ground is so small, that it could hardly be wrongly planted with a vegetable liked by the family: Potatoes or Cabbages for instance. The fumigating of the conservatory with tobacco will not injure the fish in the aquarium, but with sulphur you would not only kill the plants, but jeopardise the fish.

SNAGS ON FRUIT TREES AND LIST (In Amateur).—The espalier Pear and Plum trees kept closely pinched through the summer should not have the snags cut off until the leaves fall, and then you may cut each shoot to within an inch of its base, or, if there are spurs, down to them. The pyramid Apple, Pear, and Plum trees planted in ground deficient of vegetable matter, would not be improved by a dressing of lime, though it would do no harm. Chalk would be better, covering the ground an inch deep with pieces between the size of walnuts and hens' eggs, and then mix it with the soil as well as you can. If your soil is light a good dressing of marl would be better. The most profitable Apples and Pears to be trained as oblique cordons on a wall having an east aspect but exposed to the north, would be—Apples: Red Astrachan, Summer Golden Pippin, Margil, King of the Pippins, Sam Young, Golden Pippin, Scarlet Nonpareil, Braddick's Nonpareil, Cockle Pippin, Sykehouse Russet, Court of Wick, Calville Blanche, Kedleston Pippin, Mannington's Pearmain, White Nonpareil, and Sturmer Pippin; kitchen Apples, Lord Suffolk, Nonsuch, Gravenstein, Dumelow's Seedling, Bedfordshire Foundling, Bess Pool, Striped Beefing, Rymer, and Northern Greening. Pears: Beurre Giffard, Bea Chrétien, Beurre d'Amanlis, Louise Bonne de Jersey, Conte de Lamy, Baronne de Mello, Beurre Clairgean, Beurre Diel, Dr. Trousean, Thompson's, Alexandre Lambré, Beurre d'Arenberg, Alexandre Bivort, and Zéphirin Grégoire.

FOSTER'S BOILER (T. Cor).—We sent your letter to Mr. Pearson, and the following is his reply:—"I have two of the boilers at work, and intend to have another, as they are all that I stated. Unless Mr. Cox's boiler is under the house itself, it is not likely to work if uncovered with brickwork, except at a great disadvantage. The smoke ought to be carried round, and over the outside, as in a saddle boiler. It will also act better with coal than with coke. If well set I am sure there is no boiler equal to it, unless he has one of too small a size. Mr. Foster made some little ones I never did like. Mine cost £19, and they are all I could wish.—J. R. PEARSON."

MELONS (Q. Q.).—Meredit's Hybrid Cashmere is a good fruit, not large, as you say, but with two fruit or so on a plant it attains a good size. It is to some extent a continuous bearer, the plant, unlike many other varieties, growing when the fruit is swelling. However, some persons like Melons to be small and rich; others care not how large they are, nor how much sugar is required to make them palatable. Heckfield Green-flesh or Hybrid is an excellent sort, little, if at all, different from Meredit's; but whether the one or the other be grown, with fair cultivation a good crop of Melons, good in appearance and quality, will result. If anything, the Heckfield has the better constitution.

SMALL GREENHOUSE (B. S.).—We approve of all you have done and propose doing, except adding a fourth of leaves and rotten vegetables to your Vina border. Instead, we would use two-thirds of the marly and sandy fresh loam, and one-third of equal parts of boiled bones, old

mortar rubbish, charcoal free of dust, and the pigeon dung well exposed to the air. We would add no other animal manure, but you may mulch the border with horse droppings. You had better have two or three squares of glass to open at the apex of the roof, in addition to those at the end, or have the proposed openings at the top of the wall. We would plant Barrington Peach, Moorpark Apricot, and two Black Hamburgs for one house, and Black Espérance or Royal Muscadine for the other. Plant the Vines as soon as you like, the others by the end of October. Protect the Vine border after planting.

FLUE-HEATING (W. E. C.).—In such a case as yours, the flue would do very well, but for a couple of yards after entering the house we would make it brick-on-bed, and cover with strong tiles. In a close chamber beneath your Cucumber-bed, strong slate would be the best covering, and that about 4 inches from the top of the flue. On the slate place 2 or 3 inches of drainage below the soil, and an inch above the slate have two or three upright drain-pipes, by pouring water down which you will obtain a moist heat from the slate, either for bottom heat by plugs, or top moist heat by opening the plugs. If economy is your object, a wall bounding your chamber, we would fill-in all round your flue and for 4 inches over it with flints, brickbats, &c. piled as open and as loosely as possible, and then finish with an inch or two of concrete for the soil to lie on, having previously fixed a few upright drain-pipes amongst the rubble, for the purpose stated above, avoiding pouring water at any time directly on the flue. In your proposed quite open chamber, and in this rough open one of brickbats, &c., it would be well to have openings to let out heat to the atmosphere when wanted in a cold day or night. By cementing the bottom of your bed you can always clear out the soil without any trouble. You could place evaporating pans on the end and back flue where open and exposed. We think the flue would be ample for the place, but if you have the small boiler and pipes doing nothing, you might fix the boiler over the fireplace. Such a boiler so placed might heat another small house.

HEATING A PIT IN SEPARATE PARTS (Fior).—You can carry out the desired arrangement on your proposed plan by having a valve on your flow-pipe as it passes into No. 2 pit, and though not absolutely required, it would be as well if you had one on the return-pipe likewise. This is all very well having the boiler at one end, and as you wish the place next the boiler to be generally heated; but you cannot heat the further pit without heating the nearer. If you had placed the boiler where the two pits or houses meet, and taken a T down and return from it with a valve on each, you could heat either part separately just as you liked. You could do the same thing without valves, in the way you allude to, by taking the flow-pipe from the boiler into a cistern—say 12 inches square by 12 deep, and placed some 12 or 18 inches above the flow-pipes in the houses. From that cistern take a flow-pipe for each house, and have plugs to fit them, and shut or open as you like.

BOILER FOR SMALL GREENHOUSE (A. B.).—A very small common saddle-back boiler, exposing 2 square feet of surface to the fire will be best. Any of the boiler-makers who advertise in our columns can supply you.

HEATING FROM HOUSE BOILER (W. S.).—The height of the greenhouse floor above the kitchen floor is of little consequence. The great point is to have the pipes in the greenhouse higher than the top of the boiler. A flow pipe taken from that which goes to the top of the house would go to the greenhouse on the right level—that is, rising a little. The valve at A would be useful in directing the flow horizontally instead of vertically, and might be opened as soon as the flow took place. On that down pipe to the greenhouse you must place your valve or stop-cock. It would be of little or no use as you show it on the return pipe at F. There would be a little risk of a careless person leaving the valve on the vertical pipe shut. To prevent any unpleasant contingency, and as there seems to be a little distance from the boiler to the greenhouse, we would cut out an opening in the top of the boiler to screw in a 1-inch strong gas pipe, make that the flow to the greenhouse, and have a return of the same size screwed into the present return pipe to the boiler. These could be packed in a box of sawdust. Let them be joined with cup ends to 3-inch pipes in the greenhouse, two of which would keep out frost, but three the length of the house would make all more safe. Even then it would be well to have the pipes in the greenhouse rising to the further end, say 3 or 4 inches, and at that end fix the smallest gas pipe, taking it up as high outside the house as the height of your hot-water cistern. We are thus particular because, though we have seen different levels heated horizontally from one vertical pipe, the heated water has such a tendency to rise, that the lowest levels have the most sluggish circulation.

NAMES OF FRUIT (J. B.).—Brown Turkey Fig. (A. H.).—If the flowers are small and of a deep red colour, we should say it is Red Roman Nectarine, a clingstone variety unworthy of cultivation. (Harrison Weir).—We cannot recognise the variety. (H. M. G.).—Pears: 1, Flemish Beauty; 3, Navez Peintre; 5, Beurre d'Amanlis; 7, Pomme Poire (Apple); 8, Seckle. Apple: 1, Broad-eyed Pippin. Your examples are so small and scrubby, possessing no characteristic features, that it is next to impossible to recognise them. (J. F. Lombard).—Pears: 1, very beautiful fruit, which we do not recognise; under what circumstances was it grown? 2, Althorp Crassane; 3, Doyenné Blanc; 7, Fondante d'Automete; others not known. (J. W. Laurie).—Apple not received. Pears: 1, Easter Beurre; 2, Black Achan. (J. P.).—Apples: 2, King of the Pippins; 3, Brabant Bellefen; 6, Rymer; 8, Dumelow's Seedling. Pears: 4, Beurre de Rance; 7, Haecon's Incomparable; 9, Easter Beurre; 1, Beurre Bosc. (Scyber).—Pears: 1, Beurre d'Amanlis; 2, Althorp Crassane; 3, Marie Louise.

NAMES OF PLANTS (M. R.).—1, *Platyloma falcata*; 2, *Pteris cretica*; 3, *Doodia caudata*; 4, *Polypodium loricum*; 5, *Davallia bullata*. (A. Constant Reader).—1, *Origanum*; *Tonrefortii*; 2, *Pentstemon gentianoides*; *Crataegus*, name next week. The Fern was *Asplenium Ruta-muraria*: by us. (A. Lancashire Lad).—The Fern was *Asplenium Ruta-muraria*: quite true. The scrap of plant sent was not that of the true Pepper plant, but of a shrub, *Schinus Mollis*, the leaves of which have a warm peppery taste, so giving rise to the name. (Memorandum).—1, *Miranda hians*; 2, *Bihisus Rosa-stansis fl.-pl.*; 3, *Begonia xanthina amorea*; 4, *Liaaria Cymbalaria*; 5, *Calathea bicolor*; 6, *Aspidistra lurida variegata*. (M. H.).—1, We do not recognise this Composite at present; 2, *Euphatorium salicifolium*. (Subscriber No. 38.).—*Muhlenbeckia complexa*. (James Carter, Ifford).—Both are *Enothera missouriensis*. (A. Sayer).—Sweet Scabiosa, *Scabiosa atropurpurea*.

POULTRY, BEE, AND PIGEON CHRONICLE.

THE BIRMINGHAM SHOW OF 1870.

An examination of the Birmingham schedule for this year does not reveal any marked novelties as on former occasions. The Council apparently consider that they have now arrived nearly at perfection, and that their long experience and reflection have at length resulted in the "very height of acme," beyond which poultry schedules can no further go: hence their programme is in most particulars similar to that of last year. I confess I think the Council are mistaken. Many and great are the real improvements they have introduced into poultry exhibitions, most of which have been approved and copied by all others of any standing; but it seems to me the show is yet trammelled and injuriously affected by the set traditions of other days. I give my difference of judgment in all humility, but it is the result of several years' observation, and has been confirmed by most of those to whom I have spoken on the subject. The one great fault universally remarked of the Birmingham Show is the immense number of inferior specimens, which make the exhibition unwholly, and render an inspection of it physically exhausting. It is understood that the subject last year engaged the attention of the authorities, and the remedy they devised was to raise the entry fees by the amount of *sixpence*! It need hardly be said that the result, though in the right direction, was not appreciable; and I am more and more convinced that the radical root of the evil is the antiquated sovereign subscription (a system exploded everywhere else), which groups most of the entries into clusters of four pens. The effect is that every exhibitor makes up his four entries if possible, and in order to do so sends often inferior birds merely for sale; whilst, on the other hand, to my personal knowledge, individuals who have possessed a single pen only, which would have been a real attraction to the show, have been deterred from sending by the knowledge that the venture would cost them 23s. The problem is to get as many good pens as possible, and to weed out the bad ones, without pecuniary loss: and I feel convinced, as do most to whom I have mentioned the matter, that to abolish subscriptions altogether, to give each exhibitor only one admission ticket (as at present the tickets are given away wholesale), and to charge, say, 12s. for a single, and 7s. 6d. for every subsequent entry, would to a great extent accomplish all these objects, and raise the tone of the show materially. Perhaps, indeed, it would then be too perfect, and those who had been so long connected with it would have to follow the example of the celebrated mechanic who spent all the ingenuity of his life upon a garden engine, and then died just as he had finished polishing the handle. Nevertheless I make the suggestion, and perhaps it may be found worth considering.

Regarding details, as already said, there is little this year to remark. In most of the leading varieties there are cups and five other prizes for the cockerel and pullet classes, with three prizes for each class of old birds. In Buff Cochins, however, owing to the liberality of amateurs, there are cups and four other prizes for the old birds, and I expect the result will be such an array of Buffs as even Birmingham can rarely boast. I fear our Light Brahma friends will be really savage, this variety being cut down to three prizes each for the old classes, and four each for the chickens. The simple truth is, it is useless for anybody to talk as if such and such prizes were "due" to any variety whatever. The only way to get good prizes is to fill large classes; and the fact is that where the prizes are equal, on an average the Dark entries are about double the Light. It is no fault of the breed; but an examination of any catalogue will show that town amateurs form a very large portion of poultry fanciers; and as no very light fowls can be kept in a town to be shown with credit, the classes will always be smaller. Take White Cochins, White Dorkings, or White Bantams—the result is always the same, and for the same obvious reason.

By the liberality of amateurs, again, there are this year four classes of Malays, of two prizes each. This will rejoice the heart of "Y. B. A. Z.;" and as there are thus eight prizes I hope on this occasion there will be rather over eight pens, if it be only for the look of the thing, and to keep each other in countenance. I cannot help thinking this breed is deteriorating very much in size as well as in numbers. It used to be a large variety, now I rarely see a Malay cock without thinking of "the tall thin gentleman with the shiny boots on."

The great blot of the schedule is the fact of there being only one class, of three prizes, for "any other variety," cock and hen having to be shown together. Every show in the kingdom, almost, gives more than this; and when we consider that Andalusians, Minorcas, Laghorns (which are now beginning to be known in England), Sultans, Silkies, Japanese, Black and Cuckoo Cochins, Guinea Fowls, and many other varieties have no other place of refuge, I cannot help thinking that the printer's imp must have feloniously abstracted three or four lines of type from the sheet before it was printed.

In the other poultry classes it is worth remark that Aylesbury Ducks have only four prizes, while Rouens have six. Time was when it was all the other way; but the Rouens first challenged, then equalled, then passed their rivals, not only in number but in weight, and the prizes now adopted may be considered to settle the point that they have now decisively won the first place, both in popularity and utility. The fact is another illustration of the argument above regarding white fowls.

In Pigeons, six classes for Carriers, and no less than ten for Pouters ought to bring a magnificent array for competition. A five-guinea cup for Blue or Silver Runts, given by Mr. T. D. Green, is rather a novelty in a Pigeon show, and I shall expect to see some big birds. A cup and four classes for Antwerps show the rapidly increasing enthusiasm in favour of this symmetrical and intelligent variety. The other classes are almost precisely the same as formerly.

In conclusion, let me express a hope that the Council will again secure a copy of the magnificent poster relating to the New York Show, which attracted so much attention last year.—L. WRIGHT.

CLASSES FOR WHITE BANTAMS.

A CORRESPONDENT signing himself "WHITE BANTAM," asks for separate classes for that variety. The truth is, White Bantams are becoming so scarce, that when they have separate classes there are never sufficient entries to pay the prize money. This has been the result at the Bristol and Clifton Show, and it is the intention of the Committee to strike out the class. At the last exhibition there were only five pens entered to compete for three prizes, respectively £3, £1 10s., and 15s. If "WHITE BANTAM" will communicate with me at once, I will endeavour to have the class retained in our next prize list, which will be shortly issued. At the same time I would be glad to hear from any amateur who will raise subscriptions for special cups for any particular variety of poultry or Pigeons at our next Show. The Committee will be glad of any such assistance.—E. CAMBRIDGE, *Cotham Brow, Bristol.*

DERIVATION OF CRÈVE-CŒUR.

In your answers to correspondents you seem to imply that the name of this breed is derived from the form of the crest, as a cloven heart. You must allow me to differ from this. There is a town in Normandy of that name, and it is from thence, as in the case of the Dorking, that the name is taken. I should add that the Caumont, Houdan, and Gournay fowls are, in the opinion of M. Jacques, "veritables ramifications du Crève-Cœur." I can bear testimony to the valuable properties of this handsome breed. They lay a large number of very fine eggs, and keep on laying through their moulting time. I have some now running under bare poles, ragged-looking creatures, yet laying every day, or nearly so.—D., *Deal.*

ORNITHOLOGICAL SOCIETIES' SHOWS—PRIZE LISTS.

I AM glad to find that such societies are increasing; but I should like to draw the attention of the secretaries and committees to the desirability of having some person appointed to unpack all specimens sent by exhibitors as soon as possible after their arrival, and to give food and water to all of them, as they suffer much from thirst, especially Pigeons, when they have to travel a long distance. I hope the Sheffield Committee will set an example to other exhibitions, and also be well supported, as some of the prizes are greatly in advance of previous shows at other places, those for the Rabbits and cage birds especially.—BIRD FANCIER.

THE SOUTHAMPTON POULTRY SHOW.—In the schedule we notice a very marked improvement upon that of former years.

as at this Show two years ago, when both the Patagonian of 14 lbs. weight, and the Belgian Hare Rabbit of 9 or 10 lbs., were sent for competition. May I suggest to exhibitors the desirability of their not speaking to or interfering with the Judge when in the discharge of his duty? To say the least of it, it does not look well, and I hope this hint will be sufficient.—C. R.

STOKESLEY AGRICULTURAL SOCIETY'S POULTRY SHOW.

On the 22nd the Stokesley Show was held. The poultry were well shown in wire pens under cover, and the entries in most of the classes were large. *Dorkings* were few in number and not good. *Spanish* were also not good, with the exception of the hen in the second-prize pen. *Game* were large classes and in fine form. Mr. Blackburn's second-prize cockerel, although undubbed, was a most remarkable bird and will be heard of again. In *Hamburgs* the mistake was made of showing Pencilled and Spangled birds together. If committees cannot afford to have four classes they should put all the Pencilled together and all the Spangled together. There were fifteen entries, and not a good pen. Adult *Brahmas* were of very moderate quality, but the chickens were not far from the mark. The *Variety* class was very strong—thirteen entries. The first prize was given to a first-rate pair of Light *Brahmas*; here a mistake was made, for there being a class for Brahma chickens they should not have been allowed in this class. The second prize was given to the best pair of Golden Poland chickens we have seen this season. There were also Houdans, Crève-Cœurs, Spanish, and Black Polands noticed by the Judge. Among *Ducks*, except the first-prize pens, there was nothing worthy of notice; but the locality has been long celebrated for its Geese and Turkeys, supplying all our noted exhibitors with their prize birds, and on this occasion it surpassed itself. There was so little difference in the *Geese* that the whole were weighed, when the scales showed a difference of 2 lbs. Whites were first in both classes; the second prize in the adult class also went to Whites, Greys only coming in second. In the young class *Turkeys* could not be surpassed at any show.

Pigeons formed a very fine collection. The first-prize Fantails well deserved their position, as did the Jacobins. In the "Variety class" a very good pen of Magpies was first, Black Trumpeters being second.

In the one class for *Rabbits* there were nine pens, consisting of Himalayans, Angoras, and Lops, among which were some very fine Rabbits.

SPANISH.—1, J. Fuller, Yarm. 2, Miss Flintoff, Newby. DORKINGS.—1, E. Barker, Stokesley. 2, Mrs. Storey, Stokesley. *Cock*.—1, Rev. J. E. Newton. 2, E. Barker. *Chickens*.—1, E. Barker. 2, Rev. J. P. Newby. *Game*.—*Willow-legged*.—1 and c, T. Blackburn, jun., Great Broughton. 2, W. Gattenby. *Yellow-legged*.—1, Lox, Stokesley. 2, Withheld. *Cock*.—1, M. Peiron, Great Aylton. 2, T. Blackburn, jun. *Chickens*.—1 and c, T. Blackburn, jun. 2, W. Gattenby. *HAMBURGS*.—*Silver-pencilled or Spangled*.—1, W. Dale, Danby, Yarm. 2, H. Garbutt, Yarm. *Golden-pencilled or Spangled*.—1, G. Seely, Dromony. 2, R. Appleton, Seamer. *BRAHMA POOTERS*.—1, J. Booth, Lythe, Whiby. 2, J. Clemmet, Stokesley. *Chickens*.—1 and 2, J. Clemmet. *ANY OTHER VARIETY*.—Mrs. S. Richardson. 2, H. Garbutt, Yarm. (Poland) c, Lady D. Yeoman, Whiby (2); J. Fuller; G. Seely. *BANTAMS*.—1 and c, E. Barker, Stokesley. 2, T. Blackburn, jun. *DUCKS*.—*Any Breed*.—1, Mrs. Fidler (Aylesbury). 2, J. Mitchell, Castleton (Rouen). *Ducklings*.—1, Mrs. Storey, Stokesley. 2, Mrs. Jackson (Aylesbury). *GEESE*.—1, Mrs. Storey (White). 2, Mrs. Braithwaite, Stokesley (White). *GOSLINGS*.—1, Mrs. Storey (White). 2, Mrs. Hindson (Grey). c, Mrs. Braithwaite (White); Mrs. Storey (White). *TURKEYS*.—1, Mrs. Braithwaite. 2, W. R. L. Hopkins, *Poult*.—1, Mrs. W. Ward, Bannid Flat, Whiby. 2, H. Elthf, Seamer. *he* and c, Mrs. Storey.

PIGEONS.

FANTAILS.—1 and 2, T. C. Taylor, Middlebrough. *POUTERS*.—1 and 2, T. C. Taylor. *CARRIERS*.—1 and 2, T. C. Taylor. *JACOBINS*.—1, R. Pearson, Danby. 2, W. Dale. c, J. Garbutt, Farncliffe. *TOMBERS*.—1, T. Robinson, Fryup Head, Castleton. 2, J. Garbutt, c, W. Rudsdale; T. C. Taylor; W. Carter, Staunton. *ANY OTHER VARIETY*.—1, W. Dale. 2, W. R. L. Hopkins. *Poult*.—c, W. Rudsdale; W. O. Garbutt (Barbs and Tarbits).

RABBITS.—*Fancy*.—1, W. Cross, Raswarp Hill, Whiby (Black and Dun) 2, J. T. Ranson, Stokesley (Himalayan). *he*, G. Skeen, Stokesley (Himalayan). c, W. Carter, Staunton.

Mr. Samuel Barn, Whiby, was the Judge.

WETHERBY POULTRY SHOW.

The Show was held on the 23rd inst., and was a complete success. *Geese* came first in the list. Both the winning pens were Toulouse of great size and weight. The *Aylesbury Ducks* were good in beak and plumage, likewise the ducklings. There was but one pen of *Turkeys* of the Cambridge variety, but they were very fine. *Cochins* were poor, but the *Spanish* were very good, notably the chickens. The most striking pens of all were those of the *Dorking* chickens, which were of extraordinary size. The *Game* were good in both classes, but with the exception of the Silver-pencilled birds the *Hamburgs* were poor. The first prize in the "Variety class" was taken by Brahma chickens of great merit, and some of the *Bantams* were very good, although the *Game* were rather late in feather. There were also a few *Pigeons* and *Rabbits* in the class for extra stock.

GEESE.—1, O. A. Young, Driffield. 2, J. Simpson, Spofforth. *he*, T. Ripley; W. Wheelhouse, Linton. *DUCKS*.—1, O. A. Young. 2, H. S. Thompson. *Ducklings*.—1 and 2, O. A. Young. *he*, H. S. Thompson. *TURKEYS*.—1, Mrs. Gunter. *GUINEA FOWLS*.—1, O. A. Young. *COCHIN-CHINAS*.—1, Messrs. Pickard, Thorner. 2, R. R. Farrer, Green Hamerton. *Chickens*.—1, O. A. Young. *SPANISH* (Black).—1, Messrs. Pickard. 2, O. A. Young. *Chickens*.—1, Messrs. Pickard. 2, T. Beaumont. *he*, J. Foot, Boakings. 1, Mrs. Gunter. *Chickens*.—1 and 2, T. E. Kell, Wetherby. *he*, R. R. Farrer. *GAME*.—1 and 2, J. Watson. *he*, T.

Hawkes, Hunsingore. *Chickens*.—1, J. Watson. 2, J. Robshaw, Whixley. *he*, R. R. Farrer. *POLANDS*.—1, Messrs. Pickard. *HAMBURGS*—*Golden*.—1, G. Allen, Collingham. *Chickens*.—1, O. A. Young. *Silver*.—1, H. S. Thompson. *Chickens*.—1, J. Watson. 2, O. A. Young. *CHITTEPATI*.—1, Triffitt, Catta. *Chickens*.—1, J. Watson. *BARNDOR or CROSS BREED*.—1, Mrs. Gunter. 2, O. A. Young. *Chickens*.—1, Mrs. Gunter. *ANY DISTINCT BREED*.—1, R. R. Farrer. 2, H. S. Thompson. *Chickens*.—1, Knowles, Wetherby. 2, J. Watson. *BANTAM*.—*Silver or Gold-laced*.—1, O. A. Young. *Black*.—1, J. Watson. *Any other Variety*.—1, O. A. Young. 2, J. Watson. *Cockers*.—1, J. C. Taylor. 2 and 3, O. A. Young. *EXTRA STOCK*.—*Rabbits*.—1, G. Chambers (Angora). *he* (Spanish).—1, Watson. 2, J. Watson. 3, R. Vincent. 4, W. H. Roberts, Spofforth. *he*, O. A. Young.

JUDGE.—Mr. E. Hutton, Pudsey, Leeds.

WELSHPOOL POULTRY SHOW.

This Poultry Show in connection with the Montgomeryshire Agricultural Society was held at Welshpool on the 23rd inst. The *Dorkings* and "Any Variety" classes were well represented. Subjoined is the prize list:—

GAME.—*Black or Brown Red*.—1 and 2, E. Pugh, Welshpool. *he*, Capt. Beck, Galsfield. *Cock*.—1, Capt. Beck. 2, E. C. Pugh. *DORKINGS*.—1, 2, and *he*, Miss Williams, Henllys, Berriew. *SPANISH*.—1, P. L. Edwards, Montgomery. *HAMBURGS*.—*Black*.—1, T. Morris, Henfoes. *Gold or Silver-spangled or Pencilled*.—1, J. Morris, Welshpool. 2, W. Rogers, Welshpool. *ANY OTHER VARIETY*.—1 and 2, Miss Williams. *he*, Miss Williams; F. Williams, Kerry. *DUCKS*.—*Rouen*.—1, Capt. Beck. 2, W. Yearels, Spring Bank. *he*, Miss Williams. *GEESE*.—1, Mrs. Lloyd, Mydod. 2, G. Evans, Moelygarth. *TURKEYS*. 1, Miss Williams.

JUDGE.—Rev. A. G. Brooke, Rayton XI-Towns, Salop.

BRECONSHIRE AGRICULTURAL SOCIETY'S POULTRY SHOW.

The first show of poultry was held in the Cattle Market, Brecon, on the 21st inst. It was well conducted, and great interest was shown by the Committee in the welfare of the poultry entrusted to their care.

In the class for *Red Game* the birds were very poor, but the *Dorkings* were nearly as good as we have seen this season. The *Dorkings* were numerous, and some of the birds good; and the winning *Cochins* were both Buff, the first-prize birds being chickens, and the second adults. The local cup was won by a pen of *Dark Brahmas*; the second and third prize birds in the Brahma class were both Light, and all three pens were very good. The first-prize *Silver-spangled* were the only birds of merit in the *Hamburg* classes. The *Game Bantams* were in good numbers, the first being *Black Reds* of good quality, and the second *Brown Reds*; and in the "Variety class," Blacks were first and *Rumpless* second. There were some excellent *Ducks*, both *Aylesbury* and *Rouen*, and the local cup for aquatic birds was won by the *Aylesburys*. The *Geese* were large and in excellent order; white *Emden* first, with *Toulouse* second; and of the *Turkeys*, Blacks were first and handsome Whites second.

GAME.—*Black or Brown-breasted Red*.—1, Withheld. 2, W. Williams. *Any Variety*.—1, G. S. Cole, Llanelly. 2, J. Mitchell, Birmingham. *SPANISH*.—1, T. A. V. Vastalyfara. 2, W. Davies, Brecon. *DORKINGS* (Any variety).—1, E. Shaw, Plas Wmot, Oswestry. 2, R. Rees, Dorigan. 3, Rev. H. Price, Llanfynyach. *COCHIN-CHINAS* (Any variety).—1, — Thomas. 2, D. W. J. Thomas. 3, J. P. Gwynne, Holford, M.P., Heolias. *BRAHMA POOTERS* (Any variety).—1 and Special prize for best pen of Fowls, Rev. J. Bowen, Treffarnne. 2, Rev. N. J. Ridley, Newbury. 3, T. A. Dean, Moreton-on-Lugg. *he*, Rev. L. U. Jones, Llanugast, Brecon; Rev. J. J. Evans, Cantref. c, G. J. May, Neath. *HAMBURGS*.—*Gold and Silver-spangled*.—1, J. H. Howe, Newport, Manchester. 2, Miss G. E. Palmer, Lichborne, Warwick. *he*, W. White, Gloucester. *ANY OTHER VARIETY*.—1, Mrs. E. Williams, Henllys, Berriew, Montgomeryshire (Crested). 2, J. H. Howe. 3, Rev. N. J. Ridley, Newbury (French). *GAME BANTAMS*.—1, Mrs. E. C. Phillips, Yennfych, Brecon. 2, — Lewis, Abergavenny. *he*, J. Mayo, Gloucester; F. Cooper, Cirencester. c, E. C. Phillips. *Any variety*.—1, S. & R. Ashton, Mottram, Cheshire (Black). 2, F. Cooper (Rumpless). *SELLING CLASS*.—1, J. P. G. Holford, M.P. (Dorkings). 2, H. E. Thomas, Brecon (Cochin-China). 3, F. W. Garbutt, Newport (Andalusian). *he*, J. H. Lanford, Rustington, Bristol (Polish). c, T. T. Evans; E. Webb, Brecon (Cochin-China). *EXTRA CLASS*.—Prize given by C. A. Wood, Esq.—1, T. Gabriel, Devynock (Spanish). 1, D. W. J. Thomas (Cochins). 2, Rev. H. Price, Llanfynyach (Dorkings). *he*, H. E. Thomas (Cochins). c, H. E. Thomas (Cochins); E. C. Phillips (Duckwing Game); W. Parker, Brecon (Game Bantams). *DUCKS*.—*Aylesbury*.—1 and Special prize for best pen of Ducks, E. C. Phillips. 2, D. Llan, Bardwick, Gloucester. *he*, E. C. Phillips. c, Holford. *Bantam*.—1, W. Cooper, Abergavenny. 2, E. Shaw. *he*, Rev. J. J. Evans; W. Lewis, Abergavenny; — Richards, Llanfaes, *Selling Class*.—1, E. Shaw (Rouen). 2, J. P. G. Holford, M.P. (Rouen). 3, J. J. Evans (Rouen). *SWEETSTAKES*.—1, E. C. Phillips (Game Cock). *GEESE*.—1, R. Rees. 2, T. Edwards, Brecon (Grey). *he*, R. Rees; E. Shaw (Toulouse); T. E. Trev, Rhydymed, Brecon. *TURKEYS*.—1, Mrs. G. Holford (Black). 2, R. Parry, Penlan, Brecon (White).

JUDGE.—Mr. E. Hutton, Pudsey, Leeds.

WALSALL POULTRY SHOW.

This formed part of the Staffordshire Agricultural Society's Exhibition, and took place on the 22nd inst. It was a decided success. The day was remarkably fine, and the visitors were so numerous that it was almost impossible to pass through the poultry tent, although it was unusually spacious. The show of poultry was unquestionably good, though, perhaps, somewhat reduced as to the number of pens, from the fact of three or four other noted shows taking place the same week. With the exception of *Turkeys*, all birds shown were to be of this year, yet, whether by negligence or design, several old birds were exhibited, and necessarily without success. *Game* were good, *Spanish* equally so, but in this class the most barfaced ease of trimming took place that has been noted for many months past, instant disqualification ensuing. Many good *Grey Dorkings* were shown, and one pen of capital White. *Buff Cochins* were, with the exception of

the prize pens, not so perfect as expected, but the Partridge-coloured were first-rate. The *Hamburgh* classes were exceedingly strong. The Duke of Sutherland took all the principal prizes with really grand pens. Some very good *Brahmas*, both Light and Dark, were shown, but mostly too young to be in good show trim. It will take at least a month, perhaps six weeks longer, to bring them to perfection. *Turkeys, Geese, and Ducks* were strong classes as to excellence, but the more than questionable ages of some of the so-called Goslings caused considerable merriment among the bystanders and loss of expenses to the contributors. The "Variety class" was unusually good, there being far too many perfect pens to do justice to all; but as the awards were restricted to two prizes, high commendations and one very high commendation were all that could under the circumstances be given, much to the expressed regret of the Judges. The management of the birds devolved on Mr. Thomas Rogers, of Walsall, who well fulfilled the triple duty of packing, repacking, and feeding the birds.

GAME.—*Black-breasted and other Reds.*—1 and 2, W. H. L. Clare, Twyross, Atherstone. *Drab.*—1, Draycott, Radlett. *Another Variety.*—1, W. Duensing, Newport, Salop. 2, J. Mitchell, Moseley, Birmingham. *he, J. Brasington, Longton.* **SPANISH.**—1, H. F. Cooper, Walsall. 2, J. H. Dawes, Moseley Hall, Birmingham. *Disqualified, J. F. Silthoe, Penn Fields, Wolverhampton.*—1, "trimmed." **DORKINGS—Coloured, except Silver-Greys.**—1, H. Pickles, jun., Earby. 2, C. Havers, Inglestone. *he, J. Watts, Hazelwell Hall, King's Heath, Birmingham.* *Silver-Grey or White.*—1, Miss E. Williams, Bentley, Berrys. **COCHIN-CHINAS.**—*Buff.*—1, W. F. Ryland, Erdington, Birmingham. 2, G. Sidgwick, Ryddlesden Hall, Keighley. c. J. Stephens, Walsall. *Brown, Partridge-feathered, or other Varieties.*—1 and 2, J. Stephens, *he, C. Sidgwick, BRAHMA POOTRAS.*—*Dark.*—1, E. Leech, Rochdale. 2, G. F. Whitehouse, King's Heath, Birmingham. *he, S. A. Cooper, Walsall.* *Light.*—1 and 2, Mrs. A. Williamson, Queenborough Hall, Leicester. *he, H. Dowsett, Pleshey, Chelmsford.* c. A. O. Worthington, Newton Park, Burton-on-Trent. **HAMBOURG.**—*Gold-spangled.*—1 and *he, Duke of Sutherland, Ryddlesden Hall, Keighley, Yorkshire.* c. W. K. Tucker, Ipswich. *he, Pickles, jun., Silver-spangled.*—1 and *he, Duke of Sutherland, 2, H. Pickles, jun., Golden-spangled.*—1, Duke of Sutherland. 2, T. May, Wolverhampton. c. G. F. Whitehouse; T. Boulton, Hinford, Stoke-on-Trent. *Silver-spangled.*—1, Duke of Sutherland. 2, G. Brown, Sandhills, Walsall. *he, H. Pickles, jun.; G. Brown, TURKEYS.*—1, F. E. Richardson, Bramshall, Uttoxeter. 2, E. Leech, *he, Rev. E. C. Perry, Selchorth Vicarage, Stafford; Rev. J. H. Holliday, Holliday House, Northwich, Cheshire.* c. W. S. Scatton, Hartwell, Aylesbury. 2, E. Leech, *DUCKS.*—*Aylesbury.*—1, E. Leech. 2 and *he, Mrs. Scamsons, Rouen.*—1, S. H. Stott, Quarry Hill, Rochdale. 2, E. Leech, *he, Duke of Sutherland; S. H. Stott, c. A. O. Worthington.* *Any other Variety.*—1, J. Stephens. 2, A. O. Worthington. **ANY OTHER VARIETY**—1, Duke of Sutherland (Black Hamburghs). 2, H. Pickles, jun. (Silver Poland). *he, Miss E. Williams (Crève-Cœur).* *he, A. D. Payne, Lyth Hill, Shrewsbury (Malays); Miss E. Williams (Houdans); J. Watts (Black Hamburghs).* c. J. Stephens (Bantams).

Mr. Edward Hewitt, of Birmingham, and the Rev. G. A. Crooke, Ruyton XI-Towns, Salop, were the Judges.

WOODSTOCK POULTRY SHOW.

This was held in Blenheim Park on the 20th inst., and was the largest yet seen at Woodstock. The *Tycons*, *Aylesbury* ducklings, and *Rouen Ducks* were good. In the "Any other variety" Duck class most of the honours went to the Black East Indians shown by Mr. W. R. Pratt. The *Geese* and *Dorkings* were very fine.

SPANISH.—1 and 2, Mr. King, Oxford. **DORKINGS.**—1, Mr. Hunt, Thrup. 2, Duchess of Marlborough. 3, Mr. Salter. *Chickens.*—1, Mr. Salter, Oxford. 2 and 3, Duchess of Marlborough, Blenheim. c. Mr. Woodford. **BRAHMAS.**—1, Hon. Mrs. Devereux. 2, Col. Thomas. *Chickens.*—1, Hon. Mrs. Devereux. 2, Col. Thomas. **COCHINS.**—1, Mr. Johnson. 2, Mr. Salter, Oxford. **HAMBOURG.**—*Spangled.*—1, Mr. King. 2, Mr. Scott. *Pencil.*—1, Mr. Salter. 2, Mr. Amies. *Chickens.*—1, Mr. Amies. 2, Mr. Hunt. *Game.*—1, Mr. Hunt. 2, Mr. Woodford. *Chickens.*—1, Mr. Hunt. 2, Mr. Woodford. **BANTAMS.**—1, Mr. King. 2, Mr. Quarterman. **ANY OTHER VARIETY.**—1, Mr. Stevenson. 2, Mr. King. **GESE.**—1, Mr. Sanders. 2, Duchess of Marlborough. 3, Mr. H. Barnett. 4, Mr. G. Blake. **DUCKS.**—*Aylesbury.*—1, Mr. Quarterman. 2, Col. Bowyer. 3, Duchess of Marlborough. *Ducklings.*—1, Mr. Amies. 2, Mr. Bateman. 3, Col. Bowyer. *he, Mr. Quarterman.* c. Mr. Woodfield. **ROUEN.**—1 and 2, Mr. Salter. *Ducklings.*—1, Mr. Hunt. 2, Mr. Woodford. *he, Mr. Pratt; Mr. Quarterman.* *Any other Variety.*—1, Mr. Pratt. 2, Mr. Lester. *Young.*—1, 2, and *he, Mr. Pratt.* **TURKEYS.**—*Black.*—1 and 2, Duchess of Marlborough. *Grey.*—1 and *he, Col. Bowyer.* 2, Duchess of Marlborough. **PIGEONS.**—1, 2, and 3, Mr. Salter. *he, Mr. Salter; Mr. Pratt.*

SPECIAL PRIZES given by the Duchess of Marlborough for a collection of poultry.—1, Mr. Woodford. 2, Mr. Hunt. *he, Mr. Pratt.* Champion prize given by the Earl of Jersey for best pen of young poultry.—Mr. Amies (Aylesbury Ducks). *Old.*—Duchess of Marlborough (Black Turkeys).

Mr. H. Yardley, of Birmingham, was Judge.

USES OF CARBOLIC ACID.

In "our Journal" of September 2nd, 1869, reference was made to the employment by "APICOLA," of a piece of sponge dipped in carbolic acid, and inserted in a fumigator, whereby the use of burning material to produce smoke was rendered unnecessary. I have now to add, that by the aid of a feather having its tip wetted with the acid most operations in the apiary may be comfortably performed. If it is desired to examine a Woodbury hive, the procedure may be as follows:—Open the central hole and touch the bees that crowd around it with the acid, and they will immediately descend helter-skelter amongst the combs. In the next place gently raise the top board just enough to allow the feather to be drawn all round between it and the frames. As soon as this is done the board may be removed, and the frames elevated, using if necessary the feather to quiet and disperse any angry groups that threaten to be troublesome.

During the swarming season I have found the acid a useful

auxiliary. You can chase the bees with it upwards or downwards at pleasure, from the stems of bushes on which swarms have settled, and from which they cannot be shaken. When lodged in the decayed heart of a tree to which there is access only by a small hole, the swarm can be brought to the outside by simply tying the feather on a flexible rod, and thrusting it beyond them. When far down in a chimney they can in the same way be driven up towards the top until they are within reach.

The feather and acid are also of great service when cutting out combs from the roof of a house; for in a few seconds any comb to be removed can be cleared of every bee, thus leaving the operator a freedom he would not otherwise enjoy.

The acid, no doubt, has an unpleasant odour, but its influence, when brought in contact with the wood or sealed combs in the interior of the hive, is rather beneficial than otherwise. It evaporates rapidly, and a few hours suffice to remove all evidence of its presence. Hives frequently subjected to its odour flourish amazingly, and I can well believe that it acts as a powerful agent in checking incipient disease. I have always a phial or two of it standing in my bee houses, and for a long time, when manipulating bees, I have had recourse to it alone, discarding all fumigators, whether in the shape of pipes or cigars. By thrusting a feather moistened by it into the mouth of a common straw hive, and slowly drawing it round the edge of the interior, it also answers to the preliminary of blowing a whiff of smoke in at the entrance previous to the turning-up of the hive in order to drive it.

By a little practice skilfully directed, I have no doubt that with the help of the agent referred to, any tyro would soon be able to control his bees in any situation, and direct them when they have swarmed round the thick stems of bushes into the skep or box placed near them which they are intended to occupy.

As an attraction or guide, it is desirable on setting down the skep or box to take from the cluster a handful of bees with a twig or spoon, and shake them into it. These pioneers raise a hum within, and the swarm enters more readily. This prerequisite is especially useful if the domicile intended is new, and has not been previously occupied. Bees run much more quickly into a hive to which remnants of comb adhere, than into one that has never been tenanted. Sometimes a swarm clusters all over and around the skep in which an attempt has been made to lodge them, but I have always found it a simple and easy process to drive them towards and in at the entrance with the carbolised feather.—R. S.

OUR LETTER BOX.

NORTHALLETON SHOW (W. J. S.).—We never had any notice of this Show in our columns. If a show is not of sufficient public importance to be advertised, it cannot deserve to be permanently recorded.

RUBARB BED IN POULTRY-YARD (F. C. H.).—Let the fowls run over it if they are not pests so far as the productiveness of a garden is concerned, but they are enemies to neatness. We are not sure they are not at times beneficial.

BREEDING COCHIN-CHINAS (Enthusiast).—We advise you to use a Lemon cock, at any rate for this next season; it will neutralise the effect of the Cinnamon. Cinnamon is not a favourite colour, but in Cochins classes for "Buff and Cinnamon" the common wording colour does not count, size and symmetry are essentials. Also straight combs and plain heads—i.e., not vulture heads.

FEEDING DORKINGS (C. W.).—Let them have a dry dasy rut with plenty of grass and other green meat; feed on ground oats mixed with milk, kitchen and table scraps, and meat chopped fine. You may feed this way for a month, and may twice a-week throw down a handful of peas to keep plumage. When you send them to the show wash their legs and feet quite clean. Let them have a basket that will allow them to stand upright comfortably, and let them have plenty of oat straw in it. It is always advisable to put fowls that are going to be shown together in a small pen for a few hours every day for a week before the show. They learn to know each other, and if they do not agree they will never be successful.

FRENCH BREEDS OF FOWLS (W. L.).—All the French breeds are good layers, and if any fowl has a speciality for laying in the winter, it is the Crève-Cœur. It also lays a very large egg. They are all non-sitters. The hardest is the Houdan, next the Crève-Cœur. The La Fleche are by no means hardy. We have kept Crève-Cœurs in confinement for many years, and they do well. An experiment, however, proved they lay one-third more eggs when at liberty than in confinement. You may safely choose either Houdan or Crève-Cœur. We think on the whole we prefer the latter. If you live in a town black plumage is preferable to black and white.

CHARACTERISTICS OF BLACK HAMBOURGERS (T. E.).—Perfectly black plumage, striking white deaf ear the size of a fourpenny-piece, well piked comb seated firmly on the head, and not too large, dark legs.

GAME FOWLS EOUPE (G. R.).—Your fowls are suffering from roup. Put none of them in a room, they will get worse. Give them all a dose of castor oil. Discontinue the maize. Wash their faces and nostrils with cold water and vinegar. Give pills of euphor only, each pill the size of a golden pen. Keep the houses and runs very clean. Give bread steeped in strong ale for food in damp and cold weather. Keep the diseased cock separate from the others. Baily's pills are to be had at most chemists, or at 113, Mount Street, London, W.

BILLS OF DUCKS (Sheffield).—No weight would justify a judge in giving

a prize to Aylesbury or Ronen Ducks with bad bills. The bills should be wetted and then rubbed with pumice stone till the outer skin is removed. Some rub them with sand. It improves the bills of Ducks if they are allowed to run in meadows when the cold dew is on the grass. Dark water makes dark bills, especially pent water. The colour of them is improved by having stone grit in the water.

FOWLS FOR FAMILY USE (A Monthly Reader).—You may depend upon it that no fowl will do so well in confinement as at liberty, and no fowl suffers so much from being shut up as a Poking. The fertility of eggs depends much on weather, they fail more frequently in severe, especially snowy weather, than any other; they are also frequently frosted and chilled. You cannot expect to have good sitters when you mix breeds as you do. You have Silver Hamburgs, they are non-sitters. It is very likely among the seven mixed breeds you have others. You are wilfully causing that of which you complain. Situated as you are, we see no necessity for mixed breeds at all. There is no breed that will produce eggs and chickens without proper feeding and painstaking. Where this is carried out any breed will do well. It would be far more satisfactory to us to keep only one breed. You have probably been led away like many others. When complaining you had no eggs, you were told it was because you had no Hamburgs, you bought some; still wanting eggs you were told of another breed, and you still want eggs. There is, however, a light breaking-in upon you. You say you will have earlier eggs because you have earlier pullets. You are right, and we tell you the sooner they begin to lay, the earlier they will be broody. Feed your fowls well, gather the eggs as fast as they are laid, and keep the earliest pullets every year for stock. We advise you to keep to one breed. Dorkings are best, Brahma Pootras the least trouble. We conclude as we began, never shut up a fowl if you can allow it to be at liberty.

OWL PIGEONS (A. Jackson).—The classing of Owls does not so much depend on colour as size and appearance. The African Owls are exceedingly diminutive, they to English Owls are what Short-faced Tumblers are to their longer-faced brethren. Yellow is a colour sometimes met with in English Owls. Most probably yours are English. The colour of the eye in Owls should be pearl or gravel.

DIARRHŒA IN POUTERS (H. V. S.).—Put a little sulphate of iron in their drinking water sufficient to give a decidedly inky taste. Feed entirely on old beans for a time, crum them if necessary. Put down their throats each day three hits of omentherm the size of a pea. Cleanse and lincwash the loft thoroughly, sprinkle the workwood with chloride of lime, and separate the diseased from the healthy. Pouters are very liable to diarrhœa.

SEPARATING POUTERS (P. G.).—It is not at all necessary to separate Pouters during the winter. The great Scotch fanciers do not, they merely turn the pens inside down, or remove all places of laying.

POINTS OF LOP-EARED RABBITS (A. B.).—Lop-eared Rabbits are generally judged from the seven following points when for all properties. 1st. Length of ear from tip to tip; 2, width of ear; 3, colour, as blue and white, black and white; yellow and white, grey and white, tortoiseshell or self; 4, position of ears; 5, size of eye, and the larger the better; 6, carriage of the body; 7, size. It is not often that a Rabbit is perfect in all these points, yet the nearer it approaches perfection the better, and such a specimen is of great value.

CIDER MAKING (C. T.).—The quantity of apples required for making a gallon of cider depends upon the soil, season, and the kind of apple employed, but we know it has been calculated that one peck of the best cider apples ought to yield a gallon of juice. In the grinding the fruit should be reduced as nearly as possible to a uniform consistence, in such a manner that the rinds and kernels may be scarcely discernible from the general mass, the operation proceeding slowly, with a free access of air. **Preparing the ground fruit.**—The pompage should be carried to the press in from about eighteen to twenty-four hours, and a square cake or cheese made of it by placing very clean sweet straw or reeds between the alternate layers of pulp, or pompage, or by putting it into haircloths spread upon the vats, and placing them one upon another; they are turned up on the sides, and cover over the pulp, so as nearly to meet in the centres. They should be laid very even, and ten or twelve may be laid over each other in regular layers, the square frame of the press being raised with them, keeping the pile of a uniform size. Upon the whole a strong board is placed, wider than the pile, on which the blocks of the press rest. It is of the utmost importance that the straw or reed, where it is used, should be sweet and perfectly free from fastness. Particular care ought also to be taken to keep the hair cloths sweet by frequently washing and drying. To this cake or cheese, after standing awhile, a slight pressure is at first to be given by lowering the screw of the press, which must be gradually increased as the cakes become drier, until all the must or juice is expressed, which is usually completed by a long lever and windlass, after which the juice must be strained through a coarse hair sieve, and put either into open vats or close casks. **Fermentation.**—Fermentation should not, by too much heat, be carried on too rapidly, nor by extreme cold too slowly. The degree of warmth may be understood to be between 40° or 50° of Fahrenheit's thermometer. When the liquor appears tolerably clear, and has a piquant viscus sharpness on the tongue, then the least hissing noise heard in the fermenting liquor in this state shows that the place in which it stands is too warm, and that air must be admitted. This is the critical moment for racking the liquor, which is done by drawing off the pure part into open vessels, which must be placed in a more cool situation for a day or two, after which it may be again barrelled and placed in some moderately cool situation for the winter. The casks into which the liquor is put, whenever racked off, should always be previously thoroughly scalded and dried again, and each should want several gallons of being full, to expose a larger surface to the air. Having attended to these rules so far, the cider will require very little further attention beyond filling up the vessels every two or three weeks, to supply the waste by the insensible fermentation, until the beginning of the succeeding March, at which time it may be reasonably expected the cider will be bright, pure, and in a fit state for its final racking. This should be done in fair weather; but should the cider not prove as bright and of as good a colour as desired, put 2 lbs. of lump sugar into a hoghead of cider. If you wish the cider to be of a higher colour than the fruit gives it, melt 1 lb. of loaf sugar in a stewpan over a clear fire, stirring it frequently until it comes to a very dark brown colour; then take it off the fire, and as it cools add some cider by little and little, continuing to stir it till it becomes a thin uniform fluid. About a pint of this colouring to a hoghead of cider is sufficient. Soon after the spring racking the casks may be gradually stopped by first laying the cork on the bung-hole, and in the course of a

few days forcing it very tightly into it, covering it over with melted resin, or any other similar substance. **Bottling the Cider.**—This should be done a month after the spring rackings, when the liquor has acquired in the cask its highest degree of perfection; then, when the weather is fair, let the bottles be filled, setting them by uncorked until the morning; then let the corks be driven very tightly into the necks of the bottles, tied down with small strong twine or wire, and well secured with melted resin.

BLACKBERRY WINE (Jane).—Put fully ripe blackberries into a large vessel with a tap to it; pour on as much boiling water as will cover them, and, as soon as the heat will permit, bruise them well with the hand till all the berries are broken; cover them, and in about three or four days, when the berries rise to the top, draw off the clear part into another vessel; add to every ten quarts of the liquor 1 lb. of sugar; stir it well in, and let it stand a week or ten days to work. Draw it off through a jelly-bag. Steep 4 ozs. of isinglass in one pint of sweet wine for twelve hours; then boil it slowly till dissolved; put it into one gallon of the blackberry-juice; boil them, and put all together. Let it stand a few days, and bottle.

OBTAINING AN EARLY SWARM (Super).—You had better take off the super at once, and weigh the stock hive, if its nett contents are less than 17 to 18 lbs. the bees should be fed by means of an inverted pickle-bottle filled every evening until they attain that weight.

METEOROLOGICAL OBSERVATIONS

In the Suburbs of London for the week ending September 27th.

DATE.	BAROMETER.		THERMOMETER.				Wind.	Rain.
			Air.		Earth.			
	Max.	Min.	Max.	Min.	1 ft.	2 ft.		
Wed. . . . 21	30.227	30.204	72	49	56	54	S. .00	
Thurs. . . 22	30.253	30.229	68	33	56	54	E. .00	
Fri. . . . 23	30.253	30.216	65	30	54	54	E. .00	
Sat. . . . 24	30.230	30.194	68	30	58	54	E. .00	
Sun. . . . 25	30.254	30.181	69	32	53	53	E. .00	
Mon. . . . 26	30.111	31.074	72	33	53	53	E. .00	
Tues. . . . 27	30.152	30.146	72	35	53	52	E. .00	
Mean. . .	30.211	30.178	69.43	33.20	54.71	53.48	.. 0.00	

- 21.—Foggy; very fine; clear and fine, starlight.
- 22.—Dense fog; fine, fine and clear.
- 23.—Foggy; very fine; clear and cold at night.
- 24.—Very fine; very fine; clear and fine, foggy.
- 25.—Dense fog; clear and fine; clear and fine.
- 26.—Dense fog; very fine; fine, cold wind.
- 27.—Foggy; exceedingly fine; clear, starlight.

COVENT GARDEN MARKET.—SEPTEMBER 28.

The demand is steady, but very low prices are realised, although the general description of produce is better than it has been for some time past. Peaches and Nectarines continue to be well supplied, and late varieties of Dessert Plums are abundant and good. Potato trade heavy; large quantities are offered both by rail and coastwise.

FRUIT.

	s.	d.	s.	d.		s.	d.	s.	d.
Apples.	1	0	0	2	Mulberries.	1	0	0	0
Apricots.	doz.	0	0	0	Nectarines.	doz.	2	0	4
Chestnuts.	bushel	0	0	0	Oranges.	doz.	8	10	0
Cherries.	lb.	0	6	1	Peaches.	doz.	1	0	8
Currants.	1/2 sieve	3	0	4	Pears, kitchen.	doz.	1	0	2
Black.	doz.	0	0	0	desert.	doz.	1	0	3
Figs.	doz.	0	6	1	Pine Apples.	lb.	0	0	6
Filberts.	lb.	1	0	2	Plums.	1/2 sieve	1	6	3
Cobs.	lb.	1	6	2	Quinces.	doz.	1	0	6
Gooseberries.	quart	0	0	0	Raspberries.	lb.	0	0	2
Grapes, Hothouse.	lb.	2	0	5	Strawberries.	lb.	0	0	0
Lemons.	1/2-100	10	0	10	Walnuts.	bushel	10	0	18
Melons.	each	1	0	4	do.	1/2-100	1	0	2

VEGETABLES.

	s.	d.	s.	d.		s.	d.	s.	d.
Artichokes.	doz.	0	0	0	Leeks.	bunch	0	4	0
Asparagus.	1/2-100	0	0	0	Lettuce.	doz.	1	6	3
Beans, Kidney.	1/2 sieve.	3	0	4	Mushrooms.	pottle	1	0	3
Broad.	bushel	0	0	0	Mustard & Cress.	punnet	0	2	0
Beet, Red.	doz.	2	0	3	Onions.	bushel	4	0	6
Broccoli.	doz.	0	0	0	pickling.	quart	4	0	8
Cucumbers.	each	0	6	1	Parsley.	sieve	3	0	0
Cabbage.	doz.	2	0	2	Parsnips.	doz.	0	9	1
Capiscuous.	1/2-100	1	0	1	Peas.	quart	0	0	0
Carrots.	bushel	4	0	8	Potatoes.	bushel	3	0	4
Caulliflower.	doz.	1	0	6	do.	do.	4	0	6
Celery.	bundle	1	6	2	Radishes.	doz. bunches	0	0	0
Coleworts.	doz. bunches	3	0	6	Rhubarb.	bunch	4	0	0
Courgettes.	each	0	6	1	Savoy.	doz.	0	0	0
pickling.	doz.	2	0	4	Sea-kale.	basket	0	0	0
Endive.	doz.	2	0	0	Shallots.	lb.	0	6	0
Fennel.	bunch	0	3	0	Spinach.	bushel	0	2	6
Garlic.	lb.	0	8	0	Tomatoes.	doz.	1	0	1
Herbs.	bunch	0	3	0	Turnips.	bunch	0	6	0
Horseradish.	bundle	3	0	5	Vegetable Marrows.	doz.	2	0	8

POULTRY MARKET.—SEPTEMBER 28.

TRADE has seldom been so bad as it is now, there is little demand for anything. Michaelmas becomes less year by year, but the old remark holds good, "If all Geese are good, the heaviest are worth most."

	s.	d.	s.	d.		s.	d.	s.	d.
Large Fowls.	2	0	2	6	Pigeons.	0	8	0	9
Smaller ditto.	2	0	0	0	Rabbits.	1	4	1	5
Chickens.	1	6	1	2	Wild ditto.	0	9	0	10
Ducks.	2	0	2	6	Hares.	0	0	0	0
Geese.	6	0	11	0	Partridges.	1	2	1	4
Turkeys.	0	0	0	0	Grouse.	2	0	3	0

WEEKLY CALENDAR.

Day of Month	Day of Week.	OCTOBER 6—12, 1870.										Day of Year.					
		Average Temperature near London.			Rain in last 43 years.	Sun Rises.		Sun Sets.		Moon Rises.			Moon Sets.	Moon's Age.	Clock after Sun.		
		Day.	Night.	Mean.	Days.	m.	h.	m.	h.	m.	h.	m.	h.	Days.	m.	h.	
6	Th	61.8	49.2	52.5	22	10	af 6	27	af 5	57	af 4	13	af 2	11	11	50	279
7	F	63.7	43.4	53.6	21	12	6	25	5	16	5	24	3	12	12	8	280
8	S	61.7	42.9	51.8	22	11	6	22	5	34	5	33	4	15	12	25	281
9	SUN	60.7	42.4	51.5	24	16	6	20	5	51	5	40	5	0	12	41	282
10	M	61.6	43.3	52.4	24	17	6	18	5	9	6	47	6	15	12	57	283
11	Tu	61.7	42.4	52.1	22	19	6	15	5	29	6	52	7	16	13	13	284
12	W	59.2	41.4	50.3	23	20	6	13	5	50	6	58	8	17	13	28	285

From observations taken near London during the last forty-three years, the average day temperature of the week is 61.5°, and its night temperature 42.6°. The greatest heat was 77°, on the 9th, 1861; and the lowest cold 25°, on the 11th, 1860. The greatest fall of rain was 1.00 inch.

COPINGS FOR WALLS.



THAT walls are to a garden copings are to walls—namely, protection. The one is of little use without the other. I do not think a garden is of much use without a substantial wall, or its near relation a good, thick, well-kept hedge—it matters but little which, so far as protection or shelter goes; but a wall can be used for growing fruits, some of which cannot without such aids be produced in perfection in our climate, whilst

a hedge can be used for no such purpose, takes up as much space as the wall, and requires as much support from the soil as do the trees that are grown against the wall: hence there is more to be said in favour of a wall than a hedge. But some contend that walls do not break the force of the wind so well as a hedge. There is a difference in circumstances. A walled space enclosed on every side must at all times have a sheltered part, for when the wind is blowing from, say, the west, the east side of the wall, as well as the ground, will be shielded from the wind's violence for a considerable distance. "But the wind is only diverted, the current is made to whirl past the obstacles (the walls) to its straight course, and the garden is in no respect better, if so good, as a space unenclosed, or one enclosed by hedges." That the currents of air are made to take a different course by walls to what they would were there no obstacles to the wind's direct course no one can doubt; but that does not mean that the subjects within the enclosure are exposed to an increased violence of wind, for the wind being diverted from its course, it follows that its force is either broken, directed upwards, or turned backwards from the obstacle against which it strikes. If the wind be driven upwards by a wall we know that the space for a considerable distance on the other side will derive considerable benefit, or be protected from its violence; for it is an error to suppose the wind runs up one side of a wall and down the other. If, on the other hand, the wind is thrown back, the force is broken, and the subjects on that side must feel its effects in being driven from the object against which the wind strikes.

Now, if walls are no protection, if they do not afford shelter to the space they enclose, how is it that the subjects on them are so much earlier and less damaged than those growing in open spaces? How does it happen that in unenclosed gardens the fruit is driven from the trees if strong gales occur when it is fit, or nearly so, for gathering? If walls are the cause of so much mischief by creating currents, how is it that the fruit on the trees grown against them are seldom, if ever, injured by winds? They receive its force, and sustain no damage from its violence. I cannot understand the ideas some have of walls, but I do know that unless walls are covered with trees—i. e., foliage, the winds glide from them in a way not beneficial to the plants in the ground adjoining. The wind increases in force as it runs along the wall, and it tears up whatever is in the ground near; but cover the wall with trees in leaf, or when

leaves are not there, with innumerable small branches or obstacles to the wind's running along, and its force is broken by the surface with which it comes in contact. A bare smooth surface such as a wall is of very little use in breaking the force of wind, but anything covered with foliage, whether it be a hedge or fence, is good, for the innumerable obstacles to the free passage of the wind diminish its force and reduce to a minimum the injury it does. And so it is with walls—covered with foliage they are unequalled for protection, but when bare their utility is questionable; indeed, they are then no better than a hedge, for though the hedge allows the air to pass through, the wind's force is broken, and what is lost in the space required for the roots of the hedge-plants is not more than that wasted by the exercise of the wind's force against the wall. But what has that to do with copings? Simply this, that if there is no need for walls, there is less for copings.

Walls should always be coped, otherwise the wet enters the upper part by the joints of the masonry, destroys the mortar, or whatever is used to bind the materials together, and this gone the wall soon crumbles and falls. If a wall be worth building it is worth coping, and in such a manner that the rain falling on it will run off clear of the wall, for when the coping is no wider than the wall, the latter is very little better than a wall uncoped. The rain or wet runs down one or both sides of the wall, and from the wet the mortar soon perishes and falls off, the material of which the wall is constructed being often seriously damaged.

The coping should be wide enough to cover the wall and project somewhat on both sides. There is some difference of opinion as to how much projection the coping ought to have. Some advise a considerable projection, and others but little. From the experience of both wide and narrow projecting copings I am persuaded that the latter are preferable. Two inches' projection, I am convinced, is sufficient, for a considerably wider coping than that deprives the trees of the rains and dew so refreshing to their foliage, and I am of opinion that one good natural wetting is worth half a dozen artificial ones. A wide coping not only keeps the rains and dew from the trees to a considerable extent, but the water from the coping is made to drip clear of the trees, forming all along the wall quite a channel, throwing the soil upon the lower branches, and spoiling the fruit, besides making the ground at the foot of the wall wholly unsuitable for the growth of Lettuces, &c. I am aware that some advocate a wide coping, on the ground that it checks the passing upwards of the heat. This is, no doubt, a consideration, and into it I shall enter hereafter; but a permanent coping with 2 inches' projection is all that I have found necessary for the wall—and for the trees, too, except at certain seasons.

The best coping of all is stone. It need not be more than 3 inches thick, and it ought not to be flat, but being three-quarters of an inch less in thickness on one side than the other, the water will run to that side, and the underside of that having a small throat or groove about half an inch from the edge, it will keep the water from running down the wall. The coping should have cemented joints,

The incline should be to that side of the wall of the least importance; for instance, when a wall runs east and west the coping should fall to the north, whilst if it runs north and south the coping should incline to the west, it being presumed that the east side is for Plums, Cherries, &c., and the west for Pears.

Some prefer the coping highest in the centre, with an incline to each side. This I think quite unnecessary, a flat coping with the needful incline being, in my opinion, preferable. If anything, I would have the coping hollow in the centre, inclining from the sides to the middle, along which there might be a groove falling to a certain point, from which the water could be conveyed to the ground by a spout. This would do away with drip from the wall altogether, and the expense not being much more, I would strongly advise its adoption as the best plan of all.

Next to stone, Portland stone cement coping is desirable. It closely resembles stone in appearance, is very durable, and, I am obliged to add, expensive. Slate forms a first-class coping, but is very poor in appearance compared with either stone or cement, and unless well secured is liable to get displaced. Tiles made of fireclay answer admirably. They require to be well burned, and if blue all the better. When they are red I have not found them stand frost for any great length of time. The blue colour, I believe, is given in glazing by the agency of salt used in the burning. They are usually 2½ inches thick. Very thin or light copings of any kind have a mean appearance.

As regards other copings besides that formed on the wall it is important to have one specially for the protection of the trees, for heat has a tendency to ascend, and if it be prevented doing so it cannot pass away so rapidly. Another advantage of what I shall term a tree coping is checking the downward passage of cold air, for as it is the tendency of heated air to rise, so is it of cold air to descend. In spring when frosts prevail a coping is very valuable from keeping the blossom and young fruit dry, in which state they are not so liable to injury from frost. A third advantage of this kind of coping is, that in autumn we may secure the trees having more heat and dryness than where no provision of the kind is made, and not only make certain of the full ripening of the fruit, but also of the wood for another season fruiting. It may be said, if a coping of this kind is necessary (I do not say that it is, but I consider it an advantage), why not have it permanent? I consider that it deprives the trees of the rains and dews when making their growth and swelling their fruit, and that in winter it is wholly unnecessary, the trees being all the better of its removal, for nothing in my opinion is so destructive to insect life as frost and rain.

The sort of coping I would have is a moveable one that could be put up one day and taken down the other. So far as I have experience no material is better than wood. It is lighter than many others, and when well painted lasts a long time. An inch-deal 11 inches wide answers perfectly. This width I think needful for Peaches, Apricots, Pears, and Plums, as the latter two often have their spurs some distance from the wall; but I have known 9-inch boards employed with good effect. They should be planed smooth and well painted. There is some difficulty in fixing them so as to look well. There is no question that brackets are best, but even these are very ugly if left after the coping-boards are removed, hence the supports of the coping-boards ought not to be fixtures, but, like that they uphold, be removable.

This may be effected in a variety of ways, but a good method is to fix to the face of the wall pieces of iron 1½ inch by half an inch, and 13 inches in length, with a square hole at the top 1½ inch by three-quarters of an inch, and another of half an inch, 9 inches from the top hole, with two holes for bolts to drive into the wall. The plate will on the face have the appearance of A. The plate should be let into the under side of the coping up to the top of the upper square hole, and before driving in the bolts a space an inch longer, and the same size in other respects as the upper hole, must be cut out of the face of the wall 1½ inch deep opposite to where the plate is to be fixed. The distance apart ought not to exceed 6 feet. Wrought iron is most suitable, and should be well secured by the bolts above named. These plates are to remain permanently fixed to the wall.

The brackets are of cast iron, and though they are not different in pattern from those for shelves, instead of screw-holes, they have at the top a lug 1½ inch long one way, and 1½ inch the other, and a stud at the bottom which fits the

lower square hole in the plate. The use of the lugs will be seen on reference to B.

To fix them, all we have to do is to put the top lug through the top hole in the plate and let it drop; it will hang by the lug and cannot by any possibility fall out, and the bottom lug drops in the lower square hole in the plate. The coping-boards are then put on and will fit exactly beneath the coping;

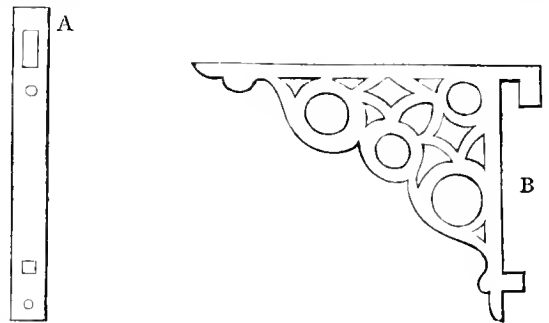

having an incline outwards, the water will drop clear of the trees. A screw will keep the board from being dislodged, a hole being at the end of the bracket, that is within an inch of the end. The whole can be taken down and put up at will, has a neat appearance when up, and there is no ugly projecting support when taken down.

The time to use the coping-boards is in spring when the blossom is approaching expansion, continuing them until danger from spring frosts is past. They may be again used in autumn when the fruit is ripening until the leaves fall, after which they should be taken down.—G. ABBEY.

BEDDING GERANIUMS.

As it is the fashion just now to report in your pages about these favourites of the garden, I feel constrained to say a few words about those which I have found answer best with me, and those which I think most promising for the future. I will begin with stating that the soil of my garden is a rich clay loam of some depth, resting on a subsoil of cold blue clay of a very unctuous character. I wish all persons in telling their experience with Geraniums or other flowers, would also describe the soil in which they grow them, otherwise their experience, however carefully reported, is of little practical use to your readers.

I may also state that my garden aims to combine something of the landscape as well as of the flower garden. There is as little formality in it as possible, but every available nook or projection in the shrubbery or the drive which leads up to the house by a winding curve is made use of to assist the general effect by a series of surprises, as it were, so that whichever way you look there is something new and diverse from anything else in the garden. I avoid as much as possible great masses of flowers of the same kind, which, to my taste, appear vulgar and offensive. Also here and there, backing up or dividing the beds, which are devoted specially to the display of any particular kind of flower, are mixed borders, which afford relief and lead on the eye to other beauties *en petite masse*. My friends admire very much in my garden the use I make of atumps, of which I have several surrounded with borders, the general effect being that of huge nosegays of various Geraniums or other flowers of differing foliage and bloom, so arranged as to bring out strong contrasts of colours.

Owing to the kindness of a friend, who is well known in the floricultural world, but who shall be nameless here for obvious reasons which he will appreciate, I have been able to enjoy and to test the value of a great number of Geraniums and other flowers, which, but for his goodness, I should, perhaps, never have possessed. Some of these I will now proceed to describe, only let your readers bear in mind what I said regarding the soil in which they are grown. In moist seasons they would, doubtless, vary in their growth. As it is, they have not grown at all rampantly, neither have they suffered from drought, as my neighbours' plants on different and lighter soils have done.

I begin with the Tricolors, which I admire exceedingly, and to which I assign the palm of beauty over all Geraniums. I have tried the following:—Mrs. Pollock, Sophia Cusack, Lady

Cullum, Defiance, Sultana Valida, Queen Victoria, Sir Robert Napier, Louisa Smith, Prince of Wales, Oberon, and Titania. Of these, the best in every way I have found to be Sir Robert Napier, by far the most distinct of this class. There is an indescribable depth and richness in the foliage, which makes it a very striking plant; but its greatest merits are—first, the facility with which it can be propagated, every cutting rooting easily, whether in the greenhouse or in the open ground; secondly, the remarkably full and vigorous habit of the plant. In these respects it is just the reverse of Mrs. Pollock. There is no legginess at all about it, and in the multitude of side shoots it throws out, it beats almost every Geranium I know. Of the rest, Mrs. Pollock comes second, but a long way after it. Prince of Wales is gorgeous as a pot plant, but it has done nothing out of doors, having, in fact, dwindled away rather than increased in size. The same may be said of Sultana Valida, Titania, and Queen Victoria. The others have done fairly, Oberon giving me a few nice cuttings well struck; but none of these do I consider promising, except as single specimens for pot culture. Titania is lovely as a pot plant; so are Defiance, Lady Cullum, and Sophia Cuesck.—B. & W.

(To be continued.)

MELONS OUT OF DOORS.

In the hope of eliciting further information from some of your correspondents on this subject, I send you a short account of the results attending my cultivation of out-door Melons this season. I should say that the idea of growing Melons in the open air was first suggested to me by a letter which appeared in the *Gardeners' Chronicle*, of December, 1869, relating the grower's own experience in the matter, from which it seemed he had not been successful last season owing to the early frosts, but thought another year success might be accomplished.

Determined to try what could be done, I wrote at the beginning of April to Messrs. Carter for a shilling's worth of the hardy ridge Melon, called Acharapennischer, a name not easily pronounced, and with greater difficulty spelt, and more easily sneezed than either. However, what's in a name? The proof of a Melon is in the eating. For my shilling I got eight seeds, which I placed in a pan, in a bed made-up for other Melons. Of the eight seeds seven came up, and in course of time the seedlings were potted off, though unfortunately three met with an untimely death from scorching. The remaining four plants were turned out at the end of May, on three little ridges, made as for hardy Cucumbers, of about 2 feet in depth of warm manure and 1 foot of common garden soil. The position was in the middle of the garden with no wall near, and on a bank sloping from the south, no other spot being just then available. A little hand-glass was put over each, and as the plants grew it was lifted higher and higher to allow them to extend.

By the third week in June they were well established and setting fruit. No particular attention was paid to them beyond an occasional watering, and, therefore, they did not probably set so many fruit as if the blossom had been carefully impregnated.

The first Melon was cut the first week in August, but it was not weighed or measured owing to my absence from home. At a rough guess I should say it weighed between 3 and 4 lbs. A second was cut the third week in August; it weighed 4 lbs. 15 ozs., and was 25 inches in circumference. A third, cut September 7th, weighed 4 lb. 8 ozs., and measured 24 inches round. A fourth (the largest of all), cut September 17th, weighed 7 lbs. 2 ozs., and measured 27 inches. A fifth, cut September 28th, weighed 6 lbs. 8 ozs., and measured 26 inches. There are three yet remaining, though not nearly equal in size to the above. The vines have almost withered, but I have replaced what remains under the hand-glasses, and I doubt not the other Melons will ripen well. Of course size is no criterion of goodness, but these Melons were as fine in flavour as any I ever tasted. I had two lots of green-fleshed Melons under glass this year, but the out-door Melons were quite equal, if not superior to them in flavour. The flesh is a bright orange, firm but melting, juicy, sweet, highly flavoured, and eatable down to the rind. The fruit is round, rough-skinned, and slightly netted. The season has, no doubt, been exceptionally favourable to the growth of out-door Melons; but I believe in most summers, especially in rather a better situation, they will be found to do equally well. I should add that the opinion as to their flavour and appearance can be verified by many gentle-

folks and gardeners of the neighbourhood who have seen and tasted them.—G. J. BLOMFIELD, *Norton Rectory, Iminster, Somerset.*

MUSHROOMS IN A LONDON CELLAR.

[THE following answer to "E. S." will be of interest to many of our readers.]

THERE can be no question as to your being able to grow Mushrooms in a London cellar, provided it is moderately dry. Taken all-in-all, a good cellar deep enough down to maintain a pretty uniform temperature is about the best place for growing Mushrooms all the year round, as it is cool in summer so that the Mushroom beds may be open, and warm enough in winter to suit the Mushrooms, especially when a little covering of sweet hay or straw is put on the beds, if the place should be rather cold. A temperature of from 50° to 55° in the atmosphere, with from 10° to 15° more in the bed, and a rather still atmosphere, are about the best conditions for free Mushroom growing.

Now with regard to your first question—Whether to make the beds on the floor or on shelves? I do not think there is much difference, all things considered. It is easiest, and requires no additional outlay, to make the bed on the floor; and there is this advantage, that the beds may be deeper than those which temporary shelves would well support, and if you are a fresh hand, I would advise you to try beds on the floor before going to the expense of making platforms or shelves one above the other. However, if resolved to make the most of your room, you could have a bed on the floor, and as many beds on shelves above it as you could find space for, provided each shelf bed were about a foot in depth, and there were a space of from 24 to 30 inches between the beds to allow of headway and ease in examining the beds. If satisfied with a bed on the floor, it should not be less than a foot in depth, but if from 15 to 20 inches deep it would bear all the longer, and maintain for a longer time a mild uniform heat. The width of the beds is of little consequence; if ranging from 4 to 5 or 6 feet they will be easily examined; if wider you will have to step on the beds at times. Hence if the width of the cellar would permit of it, I would prefer having a walk—say 24 to 30 inches wide down the middle, and a bed of 4 or 5 feet in width on each side, in preference to having one bed of 8 to 10 feet in width. If the beds are made flat you will require something, as a board, to keep up the side or sides, but you may dispense with that if you please by building your bed in a slope considerably the highest against the back wall, and coming down to the floor. In this case the pathway would not require to be so wide. I have tried both modes, and cannot say which is the better for beginners. I prefer the flat beds.

Premising merely that you have much room, I would advise you, instead of making your beds all at once, to have from two to four successions.

I will now allude to the second inquiry, "What is the best method to pursue?" This involves also the best material to be used. Some time ago I described the different means to be adopted with different materials. In London the best and most easily obtained material would be horse droppings, with about half their bulk of short littery matter mingled with them, and if obtainable, about one-quarter of rough fresh fibry loam; but it is not always to be had, and we have had fine beds without any. Its chief use is preventing violent heating, and thus more strength is left for the production of Mushrooms. The most economical way to use the droppings, &c., where the quantity is small, is to add a few inches every alternate day to the bed, beating it well, until the requisite depth is attained. This plan might not be suitable for a cellar, if the material had to come through or close to the house, and it might be advisable to have enough to make a bed or a part of a bed at once. In this case collect or purchase as many droppings, &c., as you get well, let them be thrown in a place where no rain can get at them, then put them into a heap to sweat and heat, which will also make them as much drier as will be more suitable for a bed at once. After remaining in the heap three days or more they will mostly be in a good condition for forming the bed, and should be placed in layers about 3 inches deep, one layer being well beaten before the other is added, and so going on until the bed, if flat, is say 10 inches high at the front, and 14 inches high at the back. Much depends on the beating, as the air, being thus to a certain extent excluded, the heat will be less violent, but it will continue much longer. Most likely at first, though the material is dry rather than very

wet, the heat will be too strong, and must be carefully examined from day to day, either with a thermometer or with trial sticks, before inserting the spawn. If the sticks when tried are about the heat of new milk, or the bulb of the thermometer a few inches below the surface stands at from 80° to 90°, and especially if the heat is gradually declining, you may spawn with safety. This fall in the temperature is a matter of importance, for, if the heat is increasing, it will become too much for the spawn, and you may look in vain for Mushrooms; 80° and falling may be considered a safe heat to spawn at.

The spawn, if good, may be broken in pieces a little larger than walnuts, and placed firmly just beneath the dung at about 8 inches apart. If you place it deeper, the stirring of the bed might excite fresh heating. It is better to leave all solid and smooth to prevent this heating, and if on daily examining the bed you find the temperature still inclines to fall, then you may add from 1 to 2 inches of pure droppings all over the bed, and beat it firmly, which will slightly raise the temperature and encourage the spawn to run freely. If after this you find the temperature remain uniform, or if anything slightly declining, then the bed may be earthed over with from 1½ to 2 inches of good soil. This soil should be somewhat damp, but not wet, so that it may be beaten firmly together. When this is done make the surface smooth, water it with a fine rose, and shortly afterwards draw a clean spade firmly over it, so as to leave a clean, smooth, firm surface, which will enable you easily to clean the beds afterwards with a hair broom when necessary.

Several times, notwithstanding every care, I have had to take out the pieces of spawn because the bed became too hot. With the care alluded to above, I should say that this was necessary in the case of one out of two hundred beds. In a cellar there is no absolute necessity for covering the beds, but I have found a little covering of hay, straw, or even a mat a little raised over the bed a great equaliser of heat and moisture. After earthing, when the spawn is running, the heat will be gradually increased, but not to an injurious extent, and that is always a sure sign that the spawn is running; but if after earthing-up the bed should seem to be getting rather cool, a little covering will help to raise the temperature a little so as to produce the desired result. When watering is necessary, it is well to give the water at back and front, and make a few holes with a pointed stick over the surface instead of puddling the surface all over.

If I knew better the conditions under which you are placed, I might be more particular, but attention to the above details will enable anyone to have Mushrooms in a cellar, if ordinary care be taken.

I will add, that mere slap-dash work is of no use in Mushroom-growing: the fresher the material, if you can prevent it heating too much, so much better for the Mushrooms; too much heat after spawning will render useless the best bed; too much dryness in the material will starve the spawn, unless there are free waterings, a rather difficult thing with beginners. Too much moisture in the materials will also kill the spawn, from being too wet. I have had fine beds in wet material by wrapping each piece of spawn in a handful of dry litter; this, however, is better avoided. Where droppings cannot easily be obtained, littery dung watered and worked until sweet, will grow first-rate Mushrooms, cased or not cased with horse droppings. On the whole, however, nothing beats horse droppings, and a little short litter to keep the droppings open; and the better fed the horses are, the more likely are the Mushroom beds to flourish.—R. FISH.

CYCLAMEN PERSICUM.

It may interest the lovers of Cyclamens to know how quickly they may be made to flower from seed. I sowed a packet of seed on the 26th of February this year, and my first Cyclamen was in bloom on the 12th of September. I raised more than a hundred plants from the packet of seeds, and the greater part of them are now showing flower buds. They have been kept, since sowing, in a Cucumber house until about a month ago, when the most forward were moved into a cool house. They have received no peculiar treatment, merely potting whenever they required it. The largest are now in 48 pots.—AN AMATEUR.

THE FLOWER SERMONS.—In the journal of September 22nd I find a communication by "A CONSTANT READER," page 225, in which he says that Jones, of Nayland, delivered some of

them, and that he would be glad to learn if either Jones' or any of the others' have been published. On referring to the works of Jones, of Nayland, eight volumes, Rivington, 1826, I find in vol. iv. sermon 1, "On the Religious Use of Botanical Philosophy," preached on Mr. Fairchild's foundation at the church of St. Leonard, Shoreditch, on 1st of June, 1784.—E. HURST.

STOCKS FOR APPLE GRAFTING.

"READER," page 243, inquires about various stocks. I offer my experience for what it may be found worth.

English Paradise, as far as I have been able to prove it, appears to me to be only the Barr Knot, and the French Paradise a *mélange* of sundries, two of which are varieties of Doucin—*i.e.*, the broad and narrow-leaved. The Stübert, *alias* Harvest Logging, Avant tout Léatif, and Dutch Creeper (?) is a very early Apple, often called in nurseries Dutch Cedlin, and is here in great request, although why, I am rather puzzled, as it is a very secondary sort—"soon ripe and soon rotten." None of the above are worth anything for growing healthy trees upon, and I may say the same of two kinds called the Broad and Narrow-leaved Nonesuch English Paradise; these grow the first-year's shoot well, but afterwards get so stunted as to be useless. "Amongst the faithless, faithful only" is the true Pommier de Paradis, or Malus præcox, from the Caucasian Mountains. This is a free-growing hardy stock, on which the Apple grows healthily, and bears abundant fruit of high flavour and enlarged size.

As to the Crab stock, so called, this is not raised from seeds of the wild Crab, as "READER" supposes, but is the produce of seed washed out of the pomace after cider has been extracted. The seed when sown and grown produces three qualities of stock—*i.e.*, the first culling, robust free growers, with strong roots, and fit to work orchard trees upon. The next, or second size, are nice finely-rooted plants fit for garden trees, of medium growth. The third, or small size, are generally surface-rooting stocks, fit to produce nice healthy free-bearing trees of a dwarf character. None of the above will produce fine fruit, and often not so fine either in size or flavour as the true Pommier de Paradis. I send you samples from Crabs, also from the Pommier de Paradis, to show the difference.

It must be borne in mind that Apples worked on the Pommier de Paradis require strong damp soil, and the same holds good with Pears worked upon the Quince stock.—JOHN SCOTT, Merriott Nurseries, Somerset.

LAPAGERIA ROSEA.

I HAVE now under my care, growing in a cool conservatory, and gradually covering a good portion of the roof, a plant of this fine greenhouse twiner. It came into my hands in 1865, and was then a plant about 18 inches in height, growing in a 48-pot. I planted it at the south-west corner of the conservatory, in a spot which gets some shade at the latter part of the day; and to receive the roots I made a small pit or tank, about 3 feet in length by 1 foot in width, and edged it with stone. The pit was made about 18 inches in depth, and one-third of it filled with brick rubble for drainage. The Lapageria was then planted in some bog peat, as spongy as I could get it, with which was mingled some rough sand. It soon began to grow, and flowered for the first time in 1868; since then it has bloomed yearly; and as the plant increases in size and strength, the flowers not only become more numerous, but larger and of finer quality.

My mode of treatment is as simple as it appears to be effectual. During the summer, at the growing season, I water plentifully; during the winter, when at rest, it is watered only occasionally—just enough to keep the soil moist. Occasionally I top-dress the plant with peat and sand as required; the constant watering during summer tends to wash away the soil from the roots. It is well to thoroughly top-dress at the beginning of winter, just as the summer supply of water is withheld; then the newly-added soil gets pretty well settled about the roots by the time growth commences in the spring.

I get a supply of flowers about nine months in the year; and it seeds freely, some of the pods hanging on the plant for a considerable time. The plant makes vigorous growth, and during the past summer has made shoots 16 feet in length. It has been in robust health, and made wood freely.

I find it necessary to shield the young growing shoots from the attacks of woodlice and snails and slugs. These young shoots

come up through the ground of a character similar to those of the Asparagus; and as soon as there is a slug or a woodlouse in the house, it will find its way to it, and eat away the tip of the shoots. If this happens, the growth of the shoot is checked directly, and it rarely if ever starts again. As soon as I perceive a shoot coming through the soil, I place a lamp glass over it, and keep it there till it has made sufficient growth to be out of reach of the foes.

I think a very pretty effect could be secured by blending the white with the rose-coloured variety in the interior of the roof of a suitable house. At present the former is very scarce and expensive; when it becomes cheaper, it will no doubt be grown as much as the other and older form.—GEORGE VEXNER, *The Grove Gardens, Hamwell.*—(*The Gardener.*)

ROYAL ASCOT GRAPE.

HAVING seen in THE JOURNAL OF HORTICULTURE that the Royal Ascot Grape has taken many prizes this year at various shows, and as it is again referred to at page 221, the following remarks may interest some of your readers.

Two years since I inarched Royal Ascot on Muscat de Sarnelle, growing in a ground vinery. This year I allowed it to bear eight bunches, which are now ripe. The ground vinery is 28 feet long. This year the young leading shoot is growing out beyond the vinery, and from it, for most of the way up, laterals have sprung, on each of which a bunch of Grapes appeared; all have been cut off but one, the berries of which are swelling rapidly, and should this fine season continue, I have no doubt they will ripen this autumn. The laterals growing on last year's wood were stopped three leaves above the bunches; during the summer young shoots sprung from the end of these laterals, on which bunches of Grapes came. They were again cut down to one leaf, but had I left the Grapes to ripen I should have had two bunches on the same lateral, one ripe, the other unripe, at the same time. This I consider one of the peculiarities of the Royal Ascot and worth recording, because Mr. Standish called this Vine a perpetual, and so it would be a perpetual if grown in Queensland or California, or in any country where there is no frost. The Vine came into flower a fortnight earlier than a Black Hamburg growing in the same border under another ground vinery with the same aspect.

The Royal Ascot is certainly a wonderful Vine to sprout and bear, a Vine well adapted to grow in any tropical country not too hot. Last year I inarched the Royal Ascot on a young Black Hamburg growing in an open border. On the shoot of this year's growth there is a bunch of Grapes now (28th of September), just colouring. The Vine is tied to a stake.—A. T.

MANAGEMENT OF CUTTINGS.

Is it right to allow cuttings to flag after they are taken from the plant? My gardener thinks so, but I think it is better not to allow them to feel the change more than can be avoided.—A. B.

[This is a question of some importance, and something may be said on both sides. In all milky-juiced plants and those that are very succulent it is often well to allow the cuttings to lie until the cut ends are dry. It is no bad plan in order to hasten drying and prevent the waste of juice, to stick the ends, as the cuttings are made, into fine charcoal dust. If allowed to bleed too freely the cutting is proportionably weakened, and the rooting process will be all the more languid. If such cuttings were inserted at once, the exudation of juice into the soil would afterwards be apt to make the bottom gangrene and decay. A dry base is therefore of importance in very succulent plants, but even then the drying should take place in the shade, and not in the sun, as the sun might parch and dry the part too much. Even in the case of succulent plants we never could see any benefit accruing from allowing the stems and leaves left to become wilted and flagged. We have seen whole bunches of cuttings of Geraniums made, and allowed to lie until the leaves left were all flagging. That such cuttings grow afterwards we know, because the juices and vital powers stored up are pretty good proofs against the unfair treatment given. In taking small side cuttings of such things we seldom considered any drying of the base necessary. In taking stronger, more succulent cuttings, if we deemed it advisable to let the cut end at the base dry for a few hours, we took care that the bulk of the cutting should not lose any of its juices, by slightly

sprinkling with water or shading the upper part of the cutting whilst the base was exposed.

Except in such cases, we should never think of drying the base of a cutting. Even in these cases we would secure the bulk of the cutting feeling as little as possible its severance from the parent plant. We know that many act differently, and allow the cuttings to lie a long time after being made, as if there were some virtue in this wetting and withering. They tell you that the cuttings strike root, and so they will in the case of things not easily killed, but it is in despite of, rather than as a general consequence of, the system adopted. In the summer and early autumn months you may plant a Geranium cutting, the stronger the better, full in the sun, and though the leaves will flag, the cutting will ultimately form roots and fresh leaves; but such a cutting will strike more quickly if put in a pot and placed under glass, and so top-sprinkled and shaded from strong sun that the leaves are never permitted to flag. It is true this coxing and nursing plan may easily be carried too far; too much closeness and too much shade will encourage the cutting to lengthen upwards, instead of rooting freely downwards, and hence the rough-and-ready system of planting at once out of doors is often as successful as when there is the above care carried to an excess of coddling. In all general cases we hold with you, that the cuttings cannot be too soon inserted when taken from their parent plant, and the less they feel the severance afterwards [the sooner will they strike roots.]

ABOUT POTATOES.

"MANY of them of good size, but very coarse," was the critical judgment lately passed upon a large collection of some fifty kinds of Potatoes that were staged at one of the meetings of the Royal Horticultural Society at South Kensington. This critique was just, but not sufficiently severe; for if it had proceeded to denounce in strong terms the far too prevalent practice of growing, and especially of staging for exhibition, the huge, ungainly, sunken-eyed, and altogether "coarse" samples of our noble tuber that some people seem to think the *ne plus ultra* of Potato culture, then would a service have been rendered to horticultural taste, and possibly our eyes might soon be rid of the sight of those ugly monstrosities ye call "exhibition" Potatoes. I do protest against the Potato being put on a level with Mangold Wurzel as a show-root, making size the criterion by which to judge of its merits. Nay, even in judging Mangolds some respect is paid to shape and outline; but a Mangold be it big, or little, is but a Mangold still; whilst there are Potatoes and Potatoes, the difference being just this, that whilst some are fit to go upon the table of an epicure, others are only fit diet for the pigs. The difference may be but trifling, but it is enough that it exists. If I were philosophically inclined, I might profitably moralise over the strange taste for mere size that seems to prevail among horticulturists. We have nearly gone mad in the pursuit of it in some things, and now find we have committed a huge blunder.

Big plants have had their day, and are now rather pook-pooked; big Cucumbers, also, are now looked upon as so much cattle-food by judges of taste; big Melons or other fruit must pass through the sharp ordeal of the flavour test; and so it is all through the piece. And now we have but to get rid of the strange anomaly of big Potatoes from our exhibition tables, and then we may well hope for the display in the future of such cultural results as shall both please the eye and delight the taste; and that such a reformation is near I have good reason to believe. Business pursuits took me a short time since to the classic regions of Oxford; and whilst there, how could I resist the temptation, so strong to me a "potato-ologist" (?), to drop in upon that celebrated cultivator Mr. Robert Fenn of Woodstock, and get a look at what he was doing in the way of raising new varieties, as well as note the results of his mode of cultivation?

Mr. Fenn is a strong advocate for what is known as the "ridge and trench system" of culture; which system, however, simply means that the ground, having been well prepared and manured during the previous winter, the line is laid down at intervals of 3 feet apart, the sets are then placed in a row alongside of the line, and about 15 inches distant from each other in the rows, and then the soil is thrown up over the sets with the spade, burying them to the depth of about 6 inches. Of course no earthing-up is needed, and the trenches in between are at any time available for the planting-out of winter crops. I have tried this mode of planting myself, on a

dry soil, during the past summer, with but indifferent results—that is to say, I obtained no greater produce out of a line so planted than I did from a line planted on the old method, and therefore I did not esteem the mode of cultivation a desirable one to follow. Naturally I felt desirous to note how Mr. Fenn's ridge-planted Potatoes turned out; so, when the inevitable refreshment had been partaken of, we turned out to the garden. He grasping his digging-fork with as much zeal and fervour as a soldier would his beloved rifle, and I, note-book in hand, to mark in permanent characters the results. But first I must state, to my great joy, I found Potatoes were grown both upon the ridge and the flat system in the old rectory garden at Woodstock; and after a fair comparison of the produce, we concluded that nothing was gained by ridging, as the crop in each case was about equal in a given length of row. The advantages of the ridge system appear to be two—first, a saving of seed; second, great convenience for putting out winter crops. The disadvantages are—first, more manual labour required in planting; second, a smaller crop from off a given space of ground. One thing, however, must not be forgotten. Mr. Fenn grows solely for comparison, and not for his own consumption, a few of the coarse, rank-growing varieties, of which we have far too many. His study and endeavour has long been to obtain sorts that produce but a medium green growth, and of such is the bulk of his crop; so that the necessity does not really exist for wide spaces between the rows, as the expansion of root fibres is pretty much regulated by haulm-growths. Hitherto, also, the grafting process has found in Mr. Fenn a staunch believer—not necessarily, however, in its capacity to produce great or beneficial results, but rather in its capacity to produce changes; and as I have not previously scrupled to express my doubts as to the results of any kind being obtained, the first thing to be done was to lift some roots of grafted samples, starting with Milky White, to show its natural character. We next lifted a root of the same variety grafted into a Fluke, and found the produce to be more rounded in form; there was a decided deviation both in shape and colour, the foliage also distinctly altered. Then followed Milky White grafted into Yorkshire Hero. Here the foliage presented a combination of both these kinds, but the tuber was decidedly indifferent.

Onwards, a handsome second early round of good quality was next raised, and was followed by the same variety grafted into Yorkshire Hero; that developed a later growth of foliage that was still green, and the tuber rather rougher and of coarser appearance, and showing no improvement. Yorkshire Hero grafted into Ouwards exhibited no change whatever.

Here we held a conference to discuss and compare notes; and this was the result of our conclusions: He to retain his belief in grafting, but that it produced in the Potato no beneficial results; I to forego my hitherto utter incredulity, and to recognise the principle of Potato-grafting, but with the belief that for the production of improvement in sorts thereby it was worthless.

Thus far we had cleared out of our way two important points of difference, and now turned to the more congenial, but not less interesting duty of lifting and taking notes of the seedlings and more recent kinds. I think we started with the Old Lapstone, the parent of a numerous progeny. Why, I was quite startled this year to note in my large collection how many of the sorts developed the Lapstone foliage, a growth that, once seen, can at all times be recognised—upright, stiff, with rounded incurved leaves—a most desirable sort of haulm to get to a good variety; but I fear that betwixt the sorts that now yield this form of foliage there is rather too much of the tweedledum and tweedledee difference. Here are a few of them: Lapstone, Haigh's ditto, Huntingdon Kidney, Rixton, Lady Paget, Pebble White, Crystal Palace, Ashtop Fluke (how Ashtop?), Daintree's Kidney, Yorkshire Hero, and Beaconsfield Kidney, which latter Mr. Fenn thinks, as I do, is just the old Pebble White, but having a rougher skin than the Lapstone. Mr. Turner's other new variety, Uoion, is an early round that closely resembles Walker's Seedling round in general features. The Waterloo Kidney, as usual, lifted a fine sample, and it is without exception one of the handsomest and best bred of the white kidneys that we have.

Now we come to one of Mr. Fenn's newest and choicest productions, the Rector of Woodstock, which is decidedly a good stock. It ranks as a second early, haulm of moderate growth, and turns out such handsome white round tubers, and (for we tasted them) of such excellent quality, that it must be pronounced in Potato circles a real acquisition. This Potato

has been the result of most careful selection, as some dozens of seedlings, all of the same family, were lifted, and all good, but the Rector was the best; and we were thus enabled to sign and seal Mr. Fenn's judgment, as well as that of the Fruit Committee of the Royal Horticultural Society, who last year awarded this variety a first-class certificate of merit. A fine seedling round, pink in colour, of handsome appearance and good cropper, is approved, and so is a handsome red kidney that is very promising. Then we came upon a batch of seedlings raised from that capital round variety Early Emperor, the pollen parent being Ouwards, and lift a red round, much like the Emperor parent, but it does not run out like that variety. This seedling was both handsome and prolific. Next was a pink round, much the colour of the American Rose. It was rough in skin, early, and handsome, and is named English Rose. This is a very promising kind also. A white round, with purple-blotched eyes, very handsome and promising, is next approved; and so is a peculiarly good-looking, rough-skinned red kidney, out of the same batch, that we dubbed Fenn's Bountiful, for it is a good cropper, and a real beauty. The last selected of this breed is a strong-growing white round, having pink eyes, which is very handsome, and will make a superb exhibition variety. One more seedling was from a cross between Shutford Seedling and Hogg's Coldstream. This was a fine white round that will by-and-by take a prominent place as a fine early. I think this is the one we dubbed, in a gallant spirit, Eliza Fenn, after Mr. Fenn's kind and hospitable better-half. Mr. Fenn grows altogether a large collection, having nearly all the best-known sorts that are in the market, and many of these also were looked over, but notes of them may well be left until some other time, when I may also embody with them mention of the results of my own trials. I must, however, not omit to bear witness to the great care and patient attention that Mr. Fenn bestows upon the culture of his favourite esculent, as also upon the still more difficult duty of selection. A high appreciation of beauty in shape and outline perfects his judgment; and so much did the handsome and almost perfect form of many of his new seedlings impress me, that when the next day, on passing through Reading, I looked in upon the show then being held, I became so shocked with a sight of many of the big, coarse, ugly Potato monstrosities there staged, as to have suffered for some time afterwards from Potato nightmare. I exhort people who will show Potatoes, in the future to have some regard for the outraged sensibilities of Potato critics.

Years ago, long before Moule's system of earth closets had been unearthed, Mr. Fenn put the system into operation at Woodstock. I saw his *modus operandi*, and can vouch for its simplicity, originality, and effectiveness. This is the source from which is obtained the manure that has for some years grown the Woodstock Potato, and capital stuff it is. The best time for its application is early in the winter, and then it becomes thoroughly incorporated with the soil. It, moreover, keeps the soil light and porous, and is altogether exempt from most of those objections that apply to other strong manures when used for Potato culture.

Mr. Fenn has three specialities, in each of which he is well posted—viz., Potatoes, Bees, and British Wine-making. Of the first I have written; of the second, I can only say that his hives are of the best design, full of busy bees, and that his honey is delicious; and of the third—well, readers should see and taste for themselves who can. The fine old rectory-house has its entire front enveloped with Grape Vines that are bearing, goodness only knows how many bunches; but we saw that on one chimney only there must have been at least half a hundred-weight of fruit; and then there is a large portion of garden-wall also covered with Vines, and from the entire produce I suppose will soon be brewed wine enough to fill the large cellars under the rectory-house.

Some day or other, perhaps, the Potatoes, Bees, and Wines will make a noise, for Mr. Fenn has a right to look forward for the fruits of his labours. May the kindly geniality of disposition that so strongly permeates the character of our Woodstock friend always be his! and when once more he shall shoulder the fork and go forth to his annual Potato harvest, may I be there to see!—SOUTHERN.—(*The Gardener.*)

VINE LEAVES AS FODDER.—The *Chemical News* quotes from *Les Mondes*, to the effect that Vine leaves and the cuttings of young Vine twigs are largely given in France to cattle, in a fresh state, and are also partly salted for winter forage. Since

France possesses 2,500,000 hectares of vintage ground, this new utilisation of material will furnish food for a great number of cattle.

ROYAL HORTICULTURAL SOCIETY.

OCTOBER 5TH.

THIS was one of the most crowded meetings ever held at South Kensington. There was a fair display in the floral department, a large and excellent display in the fruit department, but, after all, the great attraction, there can be no doubt, was the exhibition of Fungi. Round these during the afternoon the visitors flocked, and it was only with great difficulty that a glance of them could be obtained. The value of Fungi as an article of food has never yet, save by a few, been fully recognised. They are rich in that most valuable constituent of all articles of food—nitrogen, that constituent which least abounds in the food of the people, that which is the most nourishing, and that which is also in many of its combinations the most poisonous. For this reason Fungi, with the exception of the common Mushroom, the Truffle, and the Morel, are ever looked upon with distrust, and justly so too, for even some of those best acquainted with the family have made mistakes which have nearly had serious consequences; but there are many species with well-marked characters—characters which cannot readily be mistaken when once known—that might be utilised as articles of food by those who seldom taste butcher's meat—and their number is too many—besides being dainty morsels for the rich. But, as Mr. Wilson Saunders well remarked, we must educate the eye to distinguish that which is wholesome from that which is unwholesome, and there is no better means of doing so than exhibitions such as that we now record; and it is only to be regretted that all who came to see, from the very fact of their number, could not see so well as it might another year be arranged that they should see. The table on which the Fungi are arranged might be so placed that it might be inspected from both sides, instead of from one only, and it might be stipulated that after the close of the meeting the exhibitors should not at once carry off their collections without affording the visitors a chance of inspection.

Prizes of £2 and £1 were offered for the best collection of edible Fungi shown in Class 1; and a prize of £5 was offered by W. Wilson Saunders, Esq., F.R.S., for the best collection of edible and poisonous Fungi arranged separately. There was no exhibition in Class 1, but there were three collections shown in Class 2. The Judges decided on giving equal first prizes of £3 to Worthington G. Smith, Esq., and Mr. English, of Epping. Mr. Smith's collection contained of *edible* kinds:—Fistulina hepatica, or the Vegetable Beefsteak, Agaricus Prunulosus, A. pantherinus, A. rubescens, A. grammopodius, A. procerus, A. nebularis, Boletus scaber, B. edulis, and Lactarius deliciosus. *Poisonous* kinds:—A. phalloides, A. muscaria, A. melleus, A. squarrosus, A. fascicularis, A. sinuatus, Russula rubra, Lactarius controversus, L. vellereus, L. torminosus, Boletus luridus, Cantharellus aurantiacus, and a few others. In addition Mr. Smith exhibited a number of Fungi not known to be either edible or positively poisonous. Mr. English's collection consisted of *edible*:—A. melleus, Prunulus, campestrius, nebularis, personatus, rachodes, Boletus scaber, B. edulis, Fistulina hepatica, A. nebularis, Russula alutacea, Hydnum repandum, Amanita rubescens, Marasmius oreades. *Poisonous*:—Amanita muscaria, Boletus horvius, Lactarius vellereus, Amanita phalloides, torminosus, Amanita pantherinus, Russula rosacea, Pholiota squarrosa, Polyporus rufescens, Boletus luridus, Tricholoma nudus, &c.

The second prize went to G. W. Hoyle, Esq., and Mr. Austin, Reading, for about sixty species, many of the specimens of which were very fine. Mr. Orchard, gardener at the Priory, Wimbledon, sent a beautiful specimen of Hydnum coralloides, found growing on an Ash; and Messrs. Cripps, Tunbridge Wells, a fine specimen of Merulius lacrymans, the dry-rot Fungus, which will be alluded to hereafter. Messrs. E. G. Henderson & Son had a fine dish of Agaricus comatus.

FRUIT COMMITTEE.—G. F. Wilson, Esq., F.R.S., in the chair. Mr. William Paul, Waltham Cross, again sent examples of his seedling Grapes, which, however, the Committee failed to appreciate. W. Looke, Esq., Cleve House, Seend, Wilts, sent a curious sport from the Muscat Citronelle Grape, which is a small white one; some of the berries on the bunches were black, some white, and some striped black and white. Mr. Bogue, gardener, Gorhambury Park, St. Albans, sent a bunch of a seedling black Grape, which was not considered of any merit. Mr. C. T. Wells, Southend, Essex, sent two large baskets of Muscat Hamburg and Black Hamburg Grapes grown in his ground vinerias. The Grapes were of excellent flavour, and were awarded a special certificate. Mr. J. Colborn, gardener to J. Blyth, Esq., Woolhampton, sent some fine large examples of Salway Peaches, which were awarded a special certificate. Mr. Prentice, gardener to the Earl of Lichfield, Shugborough Park, Stafford, sent beautiful examples of Barrington Peaches, which, however, had but little flavour. Mr. Cornford, gardener to H. Streetfield, Esq., Chiddington, Kent, sent excellent examples of Walbrton Admirable Peaches, which were awarded a special certificate. Fair examples of Late Admirable Peaches were likewise shown by W. Dodson, Esq., Wilderness Park, Sevenoaks.

Mr. Thomson, gardener to Mrs. Dixon, Stanstead Park, sent good examples of Black Hamburg Grapes grown in an orchard house.

Mr. Foster, Pillington House, Leigh, Essex, sent large fruits of the Salway Peach, but quite unripe. Examples of Madresfield Court black Grape were sent from the Society's garden, Chiswick, and met with the high approbation of the Committee. A dish of Fig Mouso bianco, a green-skinned sort with a deep red flesh, and of most excellent flavour, was also sent from Chiswick.

Messrs. Rivers & Son, The Nurseries, Sawbridgeworth, exhibited an interesting collection of small Apple trees on the Noneseuch Paradise stock, heavily laden with fruit, and of very fine quality; a special certificate was awarded. Mr. H. Moore, Bradley Green, Congleton, sent examples of some seedling Pears, which were not considered of any particular merit. Mr. J. Dennis, gardener, Dresden, near Longton, Staffordshire, sent a small seedling russet Apple. Mr. J. Wade, gardener to W. Napier, Esq., Ardmore Lodge, Isleworth, sent some fine examples of Callini and Gloria Mundi Apples. Mrs. R. C. Haase, Addison Road, Kensington, sent some splendid examples of Blenheim Orange and Allington Apples, for which a special certificate was awarded. Mr. Cornford, gardener, Chiddington, Kent, sent a collection of six sorts of Apples of high merit, for which a special certificate was awarded. Mr. Garland, gardener to Sir T. D. Ackland, Killerton, Exeter, sent an example of Doyenne du Comice Pear, weighing 1 lb. 4 ozs. Mr. Beech, gardener to the Marquis of Northampton, sent some curious malformations of Manks Codlin Apple. Mr. Fenn, Woodstock, sent a pie, made of his grafted Ribston Pippin Apple, which proved rather flat.

Messrs. Cripps & Sons, nurserymen, Tunbridge Wells, sent a dish of Surpris d'Automne yellow Raspberries. From Mr. Dancer, Chiswick, came examples of Sandall's Late Plum. Mr. J. Welsh, Holley Combe, Liphook, Hants, sent an example of Prince of Wales Melon, which proved of fair quality. Mr. Heath, Newton Lodge, Middlewich, Cheshire, also sent a seedling Melon.

Mr. Scott, nurseryman, Crewkerne, Somerset, sent a splendid collection of one hundred and forty sorts of Pears, all very correctly named, for which a special certificate was awarded. Mr. Hepper, gardener to C. P. Millard, Esq., The Elms, Acton, sent a dish of Tomatoes of enormous size, for which a special certificate was awarded. Messrs. Carter & Co., High Holborn, sent a very large and fine collection of Gourds, Potatoes, Carrots, Beet, &c., for which a special certificate was awarded.

On this occasion prizes of £3 and £2 were offered by the Rev. G. Kemp, for six bunches of Grapes grown in the open air without protection. The first prize was awarded to Mr. Hepper, gardener to C. P. Millard, Esq., The Elms, Acton, for fine and well-flavoured examples of the Royal Mascadine. To Mr. J. Norris, Francis Court, Broadclyst, Devon, was awarded the second prize for good bunches of the same variety. This class was exceedingly well represented, many of the Grapes shown being well-coloured and possessed of good flavour. Amongst the most meritorious may be mentioned large and well-coloured examples of Black Hamburg, sent by Mr. W. Wood, High Street, Ewell, Surrey; also large bunches of the same variety from Mr. Davis, gardener to P. Ganley, Esq., Roehampton Park, Surrey. Examples of Royal Mascadine came from Mr. Garland, gardener to Sir T. D. Ackland, Bt., Killerton, Broadclyst, Devon; from Mr. J. Trauter, Upper Assenden, Henley-on-Thames; from Mr. Miller, gardener to J. T. Friend, Esq., Northdown, Margate; Mr. R. Lloyd, Brookwood Asylum, Woking; Mr. W. Earley, Digswell, Welwyn; and Mr. Gayton, Chesham. Good examples of Bidwell's Seedling and West's St. Peter's were sent by Mr. W. White, gardener, Crossmead Gardens, near Exeter.

By the Society prizes were offered for a collection of Black Grapes, a collection of White Grapes, a single bunch of Black Grapes, and a single bunch of White Grapes. For a collection of Black Grapes Mr. Bannerman, gardener to Lord Bagot, Blithfield, Rugeley, was awarded the first prize for fine examples of Black Hamburg, Lady Downe's, Gros Guillaume, Mrs. Pince, Alicante, Black Prince, Blithfield Seedling, and West's St. Peter's. Messrs. Lane & Sons, Great Berkhamstead, were placed second with very fair examples. For the collection of White Grapes Mr. Douglas, gardener, Lovford Hall, Ilford, Essex, and Messrs. Lane & Son, were placed equal second, the first prize being withheld.

For the best single bunch of Black Grapes Mr. Mattam, gardener to C. Longman, Esq., was first with a splendid example of Black Alicante. Mr. Laytham, gardener to Messrs. Bertram & Roberts, Rockhills, Sydenham, was placed second for the same variety, a fine large bunch. For the best white bunch Mr. C. Turner, Slough, was first with a remarkable example of Muscat of Alexandria, perfectly ripened; and Mr. Mattam second with the same variety.

FLORAL COMMITTEE.—Mr. J. Fraser in the chair. Mr. William Paul sent a remarkably fine collection of Tea Roses, the majority of them in 6 to 9-inch pots. These were in beautiful bloom, and this for the third time during the present year. Souvenir d'un Ami and Madame Willermoz were very fine; and conspicuous among the others were Madame de Vetry, Jolie Mansais, Madame Maorin, Maréchal Niel, Madame Falcot, and Vicomtesse de Cazes. To these reference will be made hereafter. A special certificate was given. Mr. W. Paul also sent boxes of cut blooms, which were fine for any season, and particularly so for the present advanced period of the year. Maréchal Niel, Souvenir d'un Ami, and Bongere were very beautiful, and Madame Falcot and Madame Pauline Labonte were also noticeable as forming richly-coloured masses. A special certificate was awarded.

From Messrs. Veitch, of Chelsea, came a collection in which were several fine specimens of *Odontoglossum grande*, *Cattleya Devoniensis*, *C. hybrida*, and *C. Dominiiana lutea*; *Rodriguezia secunda* with half a dozen racemes of its rich rose-coloured flowers; *Rhododendron Lobbiai* with splendid scarlet flowers; *Lienala spinosa* and *Corypha Martiana*, two handsome Palms *Bactris maraja*, *Calamns ciliaris*, a very graceful species, and a handsome seedling form of *Adiantum capillus-Veneris*. This was named maximum and received a first-class certificate, as likewise did *Platyterium alicorne majas*, and *Corypha Martiana*. A special certificate was given for the collection. Messrs. Veitch also sent a basket of *Retinospora obtusa aurea nana* with beautiful golden foliage. For this a special certificate was awarded.

Messrs. Backhouse, of York, received a first-class certificate for *Senecio argenteus* with handsomely-cut frosted foliage, and the same firm had a second-class certificate for a free-flowering variety of *Aster longifolius*, with bright rosy lilac flowers with a conspicuous yellow eye.

Mr. George, gardener to Miss Nicholson, Putney Heath, sent seedling *Pelargonium* Fred George, a well-marked kind. Mr. Peeke, nurseryman, Tunbridge Wells, also sent seedling *Nosegay Pelargonium*, and a seedling crested *Pteris*. Messrs. Cripps, Tunbridge Wells, exhibited a most beautiful crested form of *Pteris serrulata*, called *cristata magnifica*, forming elegant tassels, likewise a yellow variegated *Cyprinus Lawsoniana* named *lutea*, and a stand of cut blooms of hybrid *Clematises*, to show their value for late blooming out of doors. Among them were several very fine varieties.

From Mr. W. Moore, gardener to C. Leach, Esq., Clapham Park, came a splendid group of *Nerines*, including the brilliant scarlet *Nerine Fothergilli* major and *N. cousea* major, *N. humilis*, and several obtained by hybridising and by seed. A special certificate was given. Mr. C. Turner, of Slough, sent a basket of *Tricolor Pelargonium* Mrs. Healdy, with the leaves beautifully coloured.

Mr. Green, gardener to W. Wilson Saunders, Esq., Hillfield, Reigate, sent a most interesting group of *Orchids*, among which were the *Phloxia cristata*, beautiful but fugitive in its flowers; *Zygopetalum rosstratum*, with a large white lip veined with lilac at the base; a very singular *Epidendrum*, with pale green transparent flowers; *Stenia fimbriata*; *Epidendrum nocturnum*, with long tubular yellowish sepals and petals, and a white lip; *Nestrophin antennifera* and *Trichoceras parviflorus*, both with flowers of a singular character, those of the latter bearing a close resemblance to a fly. *Spiranthes margaritifera*, another singular plant, and several others were shown in this collection, for which a special certificate was given; and a similar award was made for *Miltonia Morelliana*, with very large flowers measuring 5 inches by 3½ across. Mr. Green likewise exhibited *Genera fulvida bicolor*, with brilliant scarlet flowers, white at the back of the tube and mottled with white in the throat. A special certificate was given to Mr. Deuning, gardener to Lord Londesborough, Grimston Park, for a magnificent specimen of *Dendrobium chrysothis*, a species noticed in our report of the last meeting.

Messrs. E. G. Henderson & Son, Wellington Nurseries, sent a collection of plants including several of those exhibited by the firm at the previous meeting, a brilliant group of the *Glyceria Lily* (*Nerine sarniensis*); a fine group of winter-flowering *Trees Carnations*, the pretty little golden-leaved *Thyme*; *Tricolor Pelargonium* Miss Goring, which received a first-class certificate; and *Pleroma macrantha floribunda*, with splendid violet flowers 3 inches in diameter. For this a special certificate was given, likewise one to the collection. Mr. Perkins, nurseryman, Leamington, sent *Sedum Fabarium purpureum*, which is the same as *Sedum spectabile purpureum*, shown by Messrs. Henderson. *Wigandia imperialis*, a noble plant for subtropical gardening, was also exhibited by Messrs. Henderson & Son, and had a first-class certificate.

Dahlia Monarch, a large and fine dark maroon self from Mr. Rawlings, of Romford, had a first class certificate, and a like award was made to Mr. Parker, Maiden's Green, Winkfield, for *Yellow Standard*, primrose yellow. *Prince Imperial*, buff, with a deeper-coloured centre, from Mr. C. J. Perry, had a second-class certificate. Mr. Harris, of Orpington, also sent several seedlings. Mr. Rawlings exhibited a stand of bouquet Dahlias.

Mr. Parker, Victoria Nursery, Rugby, exhibited *Ivy-leaved Pelargonium Golden Queen*, apparently a very vigorous-growing kind, with large leaves edged with yellow, and large flowers, white tinged with pink. This received a first-class certificate.

Messrs. Standish & Co. sent a collection of *Retinosporas*, among which were several variegated forms, the pretty *R. cricoides*, *R. leycopodioides*, and others. For this collection a special certificate was given.

GENERAL MEETING.—W. Wilson Saunders, Esq., F.R.S., in the chair. Several new Fellows having been elected, and the awards of the Fruit and Floral Committees announced, the Chairman called on the Rev. M. J. Berkeley to comment on the principal subjects exhibited, and particularly the Fungi. With respect to these he (the Chairman), said that such exhibitions were of importance, because the eye must be educated to distinguish the good species from the bad; it was of great importance to assure the public that the names given were correct, and it was only by the eye being made well acquainted with the forms and characters of Fungi, that it could be hoped to turn them to the use of the public generally.

Mr. Berkeley said before noticing the Fungi, he would first make some remarks on the plants shown. In the first place he would direct attention to *Dendrobium chrysothis*, a specimen of which was exhibited at

the previous meeting, but it was evident there was a great difference between it and *D. fimbriatum*, in the flowers being produced on a leafy stem, whilst in *fimbriatum* they were borne on a naked stem; there was also a considerable difference in the substance of the flowers. Several of the plants shown in Mr. Wilson Saunders's collection were then noticed, especially *Trichoceras parviflorus*, which, it was said, would be an admirable model for an artificial fly, which would prove "very killing." Messrs. Standish & Co.'s *Retinosporas* were then referred to as being most valuable Conifers, from their being nearly if not quite hardy, and it was mentioned that though in the midland counties *Cyprinus macrocarpa* had escaped the severe frosts of past years, at Chiswick a fine specimen 30 feet high had succumbed. A new wood from Panama, called the *Cordoba* (?), was then noticed as fine for cabinet work, but notwithstanding its high colour, it afforded no dye. Some specimens of the *Manks Codlin* were then shown. These came from Mr. Beech, gardener to the Marquis of Northampton, at Castle Ashby, and all of them were Siamese twins.

Coming next to the Fungi, Mr. Berkeley remarked that there was a beautiful specimen of *Hydnum coralloides*, which is extremely rare in this country. There was also a fine example of the dry-rot Fungus from Messrs. Cripps, of Tunbridge Wells. This was by far too common, and he would recommend its being committed to the flames as soon as the meeting was over, as there were probably hundreds of thousands of spores in the specimen. When the wainscoting was removed from the old Palace at Kew, there was a specimen of this many feet in diameter, which Sir William Hooker described as presenting a beautiful appearance. A saturated solution of corrosive sublimate was a remedy preventing the recurrence of the Fungus for years; but it appeared from experience with railway sleepers that those so treated did not stand so long as if creosoted. Among the Fungi exhibited there were some extremely rare, and some he had never seen before. *Agaricus melleus* was labelled both as edible and poisonous; though it was eaten in Germany, he had little doubt its use was often attended with fatal consequences. Another species exhibited among poisonous Fungi was *Boletus luridus*; now he had some time ago received a letter from Sir Walter Trevelyan, stating he was in the habit of eating this species; at first he (Mr. Berkeley) doubted this, but on specimens arriving in good condition he found that they were the genuine *B. luridus*. Other Fungi noticed were *Marasmius oreades*, which was one of the very best; the gills were far apart, pale, not brown; *A. nularis*; *Boletus edulis*, known by its mild taste, and the strong network on its stem; *A. orella*, and *A. Prunulus* (not *Badham*'s).

It was absolutely necessary that one should have some knowledge of Fungi before eating them, but the same applied to everything else; for example, the Water Cress, Horseradish, &c., for each of which Brooklime, Avonite, &c., had been mistaken. Mr. Wortington Smith had done much by publishing illustrations of edible and poisonous Fungi at a moderate price, and which were excellent guides in distinguishing the one from the other.

Mr. Berkeley then referred to Professor Huxley's address to the British Association at Liverpool, particularly in respect to spontaneous generation and to the influence of Fungi in disease. With regard to the supposed origin of cholera from Fungi, although there could be no doubt choleraic matter formed a far more favourable nidus for the low forms of life than healthy excretions, yet it was one of those things that had still to be proved, and that with great precautions. The prevalence of erysipelas in hospitals might not improbably be due to the gelatinous globules, similar to those seen on meat in an incipient state of putrefaction, being carried up in the atmosphere, and alighting on the wounds of the inmates.

The Chairman having proposed a vote of thanks to Mr. Berkeley, which was carried unanimously, called on Mr. William Paul for some remarks on the Roses he had shown.

Mr. William Paul said—The Roses before you are part of a collection which is intended to bloom from the present time to Christmas. They are all Tea-scented Roses, and this is the third time this year that they have been covered with flowers—first in May, again in July, and now in October. The flowers now out are but the beginning of the third series; the later buds on the plants will continue to unfold for a period of two or three months. The plants before you have been kept constantly under glass, although I do not hold this to be an indispensable condition of success. I have flowered Tea-scented Roses equally well out of doors up to this period, but from October onwards it is best to place them under glass, or the frost and probable rain may mar the beauty of the flowers, if it do not destroy them. Of all Roses the Tea-scented flower the most continuously and abundantly in the autumn and winter. The plants now exhibited were kept in a cold greenhouse during last winter, the frost barely excluded. They were pruned in January; and after the first flowering, which took place in May, was over, the flower-spikes were cut off, and the plants were rested by withholding water. A new growth shortly followed, producing the second flowering in July. The flower-spikes were again cut off, the plants again rested by the agency of drought. The third growth took place in August, and the commencement of the third flowering is now before you. These flowers are not so large as those previously produced, but they are valuable, and will become more so as the flowers out of doors grow less and disappear. In their future a little heat will be employed occasionally to mitigate the effect of the superabundant moisture of autumn and winter.

The next meeting was announced for November 2nd, on which day large-flowered and Pompon Chrysanthemums, berried plants in pots, Potatoes, and dessert Pears form the principal subjects to be exhibited.

THE WILLOW HERB AS A BEDDING PLANT.

WITHIN the present month we have seen used with excellent effect the common Willow Herb, *Epilobium hirsutum*. As a broad mass forming the centre of a large bed margined with a belt of something in contrast with it, it was very striking, and at a distance we concluded it was the Variegated Mint; on nearing it, however, and seeing its delicate pink blossoms (which, by the way, should not have been allowed to show), we recognised the pale form of this old acquaintance. For all the purposes for which the Variegated Mint is used this is equally valuable, and, we think, rather more effective. We had not before seen it used as a bedder, and as some of our readers may, too, be unfamiliar with its capabilities in that way, we think it well to take this opportunity of making them known.—(*Irish Farmers' Gazette*.)

PORTRAITS OF PLANTS, FLOWERS, AND FRUITS.

LISSOCHEILUS KREBII (Mr. Krieb's *Lissocheilus*). *Nat. ord.*, Oreliaceæ. *Limn.*, Gynandria Monandria.—Native of Natal. Flowers yellow.—(*Bot. Mag.*, t. 5861.)

CALOCHORTUS LEICHTLINI (Max Leichtlin's *Calochortus*). *Nat. ord.*, Liliaceæ. *Limn.*, Hexandria Monogynia.—The genus was first brought to the front by David Douglas, one of the martyrs of botany, but his discoveries have passed away from our borders, but are now reappearing. The present species, entirely new, is a native of the Sierra Nevada of California. Flowers white, with a purple blotch adjoining the nectary.—(*Ibid.*, t. 5862.)

LEPTOSIPHON PARVIFLORUS var. ROSACEUS (Rosa-flowered *Leptosiphon*). *Nat. ord.*, Polmoniaceæ. *Limn.*, Pentandria Monogynia.—“A most lovely representative of one of the most variable genera of hardy annuals.” The flowers of this variety are of various shades of colour, from pale to deep rose red. Native of California.—(*Ibid.*, t. 5863.)

PASSIFLORA ARBOREA (Tree Passionflower). *Nat. ord.*, Passifloræ. *Limn.*, Pentandria Trigynia.—Native of dense forests in the mountain districts of New Grenada, Ecuador, and Venezuela. Not so beautiful as the commoner species. Flowers greenish white.—(*Ibid.*, t. 5864.)

CLUSIA OBOVATA (Sweet-scented *Clusia*). *Nat. ord.*, Clusiaceæ. *Limn.*, Polyandria Monogynia.—“An inhabitant of the volcano of Cherqui in New Grenada.” Flowers pink.—(*Ibid.*, t. 5865.)

BARLERIA MCKENI (Mr. McKen's *Barleria*). *Nat. ord.*, Acanthaceæ. *Limn.*, Diandria Monogynia.—Native of Natal. Flowers purple. The district in which this *Barleria* is found appears to be botanically little known, and to abound in novelties. Amongst others which Mr. McKen has procured are two magnificent Heaths, a *Phenix* different from *P. reclinata*, and some fine *Oreliæ*.—(*Ibid.*, t. 5866.)

LEPTOSIPHON ROSEUS.—This is the same plant as noticed above. “If an exception be made in favour of the admirable *Phlox Drummondii*, none of the annual *Phlox*works are more popular, or so well deserve popularity, as the plants included in the genus *Leptosiphon*. Of dwarf and compact habit, yielding profusely their star-like blossoms of various shades, and of the easiest cultivation in almost any soil, it can scarcely be a matter of surprise that they have from their earliest introduction taken place in the first rank. For twenty years the genus was represented in our gardens only by the well-known *L. androsæceus* and *L. densiflorus*, with their white varieties. To these were at length added the charming *L. luteus* and its variety *anreus*, both introduced by Messrs. Veitch, of Chelsea; and another, though it may be hoped not a final addition, may now be chronicled in the *Leptosiphon roseus*, a most charming plant, closely related in habit to the two last named, which it equals, if not exceeds, in beauty and in usefulness.

“This elegant and attractive little annual differs from *L. anreus* almost solely in its colour, which is a most pleasing tender rose, a shade by no means easy to represent adequately on paper. Like that of its congener, its habit is very dwarf, rarely exceeding 3 or 4 inches, with similarly palmate foliage, the flowers being produced in clusters terminating the stems and branches. The elongated corolla-tube, so characteristic of the genus, is fully three times longer than the limb, which is about three-fourths of an inch in diameter. In most of the specimens the rose-colour is uniform, but in some there is an approach to a stripe, or flake, which, however, in no degree

detracts from the appearance of the plant. Well-grown, strong plants will yield their flowers for several weeks in succession. To obtain specimens, however, that will give the maximum number of flowers, it is essential with this, as with the other species, indeed with all other annuals, to sow thinly, or to transplant the seedlings while young to such a distance from each other as will afford full space for development. When the same care and attention that are bestowed on bedding plants are given to the hardy annuals, then, and then only, will their capabilities be discerned.”—(*Florist and Pomologist*, 3s., iii., 217.)

AMATEUR MARKET GARDENING.

It has now become a fashion for persons with independent means to plant fruit trees and to sell their produce; a few words of instruction may not be amiss to such who take pleasure in fruit culture and yet wish to derive some profit from their gardens.

APPLES.—These should be grafted on the English Paradise stock (the French Paradise stock forms pretty trees for small gardens), and cultivated either as bushes or pyramids. They should be planted 4 feet apart in rows, and the central space between the rows may be cropped with light crops, such as Onions, &c., for six, eight, or more years, till the trees meet. Their pruning should be of the simplest; from the middle to the end of June every young shoot should be shortened to half its length, and towards the end of August all the young shoots that have put forth since the June pruning should be shortened to three leaves. In winter a few autumnal shoots will still be found that require pruning, these should all be shortened to three or four buds; and if the trees are aged and a little crowded with shoots, they should be thinned with a sharp knife, and this will constitute the whole of the pruning for the year. If the soil be rich the trees may be planted 6 feet apart, or if planted at 4 feet apart, every alternate tree may be removed and replanted in fresh soil at the end of ten or twelve years. In all cases the soil should be solid—i.e., not dug, and if the trees bear too profusely so as to exhaust themselves, some decomposed manure, about five bushels to 25 square yards, should be spread on the surface in winter and left there. I have commenced with Apples because they are the fruit of the people, almost a necessary of life.

CHERRIES.—Those of the Duke and Morello tribe may be planted as bushes and pyramids, 4 feet apart, with advantage if grafted on the Mahaleb stock. The Heart and Bigarreau Cherries, unless double-grafted, do not do well as pyramids in gardens.

PEARS.—These should be grafted or budded on the Quince stock, otherwise their growth is by far too vigorous; they may be planted as bushes, and nothing in fruit culture is more beautiful than a Pear tree the size of a Gooseberry bush full of large fruit; 4 feet apart for bushes, and 6 feet apart for pyramids will be perfect culture.

PLUMS.—Next to the Apple the Plum is the most valuable domestic fruit, for it may be pre-erred all the winter without sugar or any expense, till Plums are again ready. The trees may be planted 6 feet apart, and if, as is the case with some soils, they make a vigorous growth without bearing fruit, the trees should be taken up early in November and replanted in the same place. If large trees are required, pyramidal Plums may be thinned out so as to stand 12 feet apart; their produce here by this course is something to wonder at; my trees are twenty years old. Pruning in all these cases must be that recommended for Apples.

In these short and rough notes, I have given, I trust, enough to guide those who wish to make their fruit gardens profitable. The taste for good fruit is every year increasing, and it seems as if there would always be a profitable sale for healthy fruit. I have only to note that, in the first week of this month (August, 1870), from 1000 to 2000 bushels of my Early Prolific Plums could have been sold in Covent Garden at a remunerative price; we had not a full crop, but the few hundreds of baskets sent up made me wish for more. Those who would like to know a fruit salesman, may apply to Mr. John Black, Covent Garden Market.

A few words as to market-garden planting will, I think, do good, and I give them as axioms:—Do not plant many varieties but find out by trial—i.e., planting several sorts, one tree of each sort, and closely observe them, and if you find one or two or three sorts more prolific than others, plant from fifty to five hundred of such a sort. About thirty years since I found that one tree of Louise Bonne Pear bore a crop when some hundreds of sorts failed. Our plantation of this sort on Quince stocks, for fruit for market, is now 5000 trees. And again, my Early

Rivers or Early Prolific Plum is so popular, that our plantation of bearing pyramids is now nearly 5000. Of new Pears for market, Madame Treyve is a great bearer, and most excellent Pear; Beurré de l'Assomption is large and good; Beurré Bachelier, Beurré Clairgeau, Beurré d'Amanlis, and Doyenné du Comice are good market Pears. Of Plums, Prince Engelbert, Belgian Purple, Reine Claude de Bavay, Angelina Burdett, Early Orleans, and Belle de Septembre may be planted as pyramids 6 feet apart with great advantage. I ought to mention here, that my plantation of Apple trees 3 feet apart is now ten years old and in full bearing, as are my Louise Bonne Pears, five years old, also 3 feet apart.—(Extracted from *Messrs. Rivers and Son's Descriptive Catalogue of Fruit Trees*, 1870.)

GROUND VINERIES.

THE ground-vinery system is so full of interest in itself, and offers such important advantages to those who garden on a small scale—i. e., to the many, that I fancy you will be glad to give publicity to the following statement.

There are two plans of ground vineries now proposed for acceptance. One is the plan introduced to the public by Mr. Rivers in his "Miniature Fruit Garden" some years ago, in which he recommends a framework of wood or iron in the form of a ridge, and glazed with glass. This is placed on bricks, and the Vine is trained under it on a floor of slate. The other is Mr. Rendle's plan, which for the frame of wood substitutes his patent bricks. These are built up according to the method shown in his published engravings and directions, moveable squares of glass are employed to cover in the enclosed space, and the Vine is trained within, as in the former case.

I have employed the plan recommended by Mr. Rivers for growing Grapes for two or three years with very fair success; but having occasion to lengthen my vinery, and not being able to procure any more of the iron frames for glazing which I had hitherto used, I sent for some of Mr. Rendle's bricks. I have two Vines growing side by side, and leaving one under glazed iron-ridge frames, I constructed over the other Vine Mr. Rendle's ground vinery of bricks and glass.

During the past summer I have been able to test the merits of the two plans, and in the interests of amateur gardening I proceed to tell you the results of the trial. I found Mr. Rendle's plan in every way superior to that proposed by Mr. Rivers. There was, first of all, an earlier development of the leaf and flower in Rendle's vinery, and a greater uniformity of temperature. As the season advanced the texture of the leaf, and its colour so much superior to that of the other Vine, have been a constant object of remark by myself and all who have seen the Vines, and, as a consequence, the Grapes are larger, they have ripened earlier, and have a colour, bloom, and finish which I fancy it would be difficult to surpass by any other mode of cultivation. The Vines are Black Hamburgh, and the Vine which has done so well in the Rendle vinery did not, when the two Vines were grown under the glass ridge, ripen its fruit so soon as the other.

I think, therefore, we have here a very good test of the respective merits of the two plans. I have called these methods of cultivation (between which I have drawn a comparison) by the names of Rivers and Rendle, not because there is any controversy between the two individuals as to the utility of their respective plans, but simply for distinction's sake. I know that Mr. Rivers thinks highly of Mr. Rendle's plant-protector system, and uses it.—W. E. CAPARN, *Draycot Vicarage, Weston-super-Mare*.

[Mr. Caparn sent us two bunches of Black Hamburgh Grapes; the berries on that labelled "Rendle" were larger, better coloured, and sweeter than the berries of that labelled "Rivers."—Eds.]

POMOLOGICAL GLEANINGS.

ECKLAND VALE APPLE.—Who can tell us the origin or the history of this Apple? During a short tour amongst the gardens of Ireland lately, the Apple which above all others attracted our attention, and which there seemed the most general favourite, was that called Eckland Vale. Its great size, its clear, handsome appearance, and its great productiveness on young trees and on old trees in almost every garden we visited, were very marked. The name was new to us; the Apple, however, had a somewhat familiar look, as if we had known it before under another name, yet never have we seen it, or one like it, so beautiful and fine as we found it at Mount Merrion,

near Dublin. Specimens before us now, which we picked at random from a small tree in the gardens there, are very large, upwards of 4 inches in diameter, rather flattened, or what we would call of the Pippin shape, slightly angular. The eye is large, pretty deeply sunk. Stalk deeply sunk also, about half an inch in length, the end just level with the base of the fruit. Colour pale greenish yellow, slightly flushed with crimson on the exposed side, and having a few small ferruginous specks over the surface, with a slight patch of russet near the stalk. The flesh is whitish, rather soft and light, not evidently intended to keep long, briskly acid in flavour, and delicate in texture. This is an Apple which, when cooked, will dissolve very rapidly and completely, thus fixing its place as a very excellent early autumn sauce Apple.

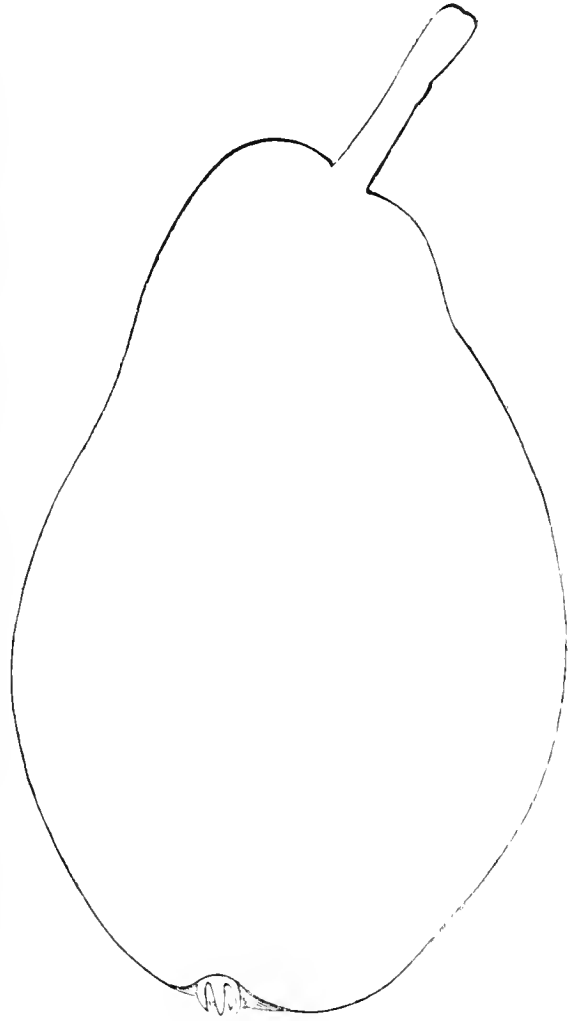

Brockworth Park Pear.

In the colouring of the fruit and some of its features it is very similar to the Wormsley Pippin and Stirling Castle. It differs from the Wormsley Pippin in having acid instead of sweet flesh, and in the stalk, &c.; and from the Stirling Castle it is likewise distinct. Some of the paler specimens resemble Small's Admirable, but it is not that. It was sent out, we are informed, from one nursery in this country a few years ago as Prizetaker, but that was merely a name adopted for trade purposes. In the gardens around Dublin it was said to be a Scotch Apple. At Belfast we were told it was an Irish seedling raised in that neighbourhood. Will some one clear up the mystery? Here is an Apple quite unknown in the London markets, but which would fetch the highest price in its season, and by its exceeding productiveness would well repay the grower.

BROCKWORTH PARK PEAR.—In September we are already so

well supplied with good and useful Pears, that new varieties seem scarcely to be required. It would appear, however, that good as our supply may be, and satisfied as we have been, there is yet room for improvement—yet room for another good Pear, Brockworth Park.

This is an English seedling, and far in advance of nineteenth-century continental trash which is year by year forced upon us. It is, indeed, a first-class Pear, and the standard is now placed high. It has been awarded a first-class certificate by the Fruit Committee of the Royal Horticultural Society. At the first glance it greatly resembles a pale Louise Bonne of Jersey. The fruit is large, pyriform, rather bulged in the centre. Skin smooth, pale yellow, slightly flushed and streaked with crimson on the exposed side. Eye small, close, segments of the calyx pointed, set in a shallow basin, the end of the fruit being frequently blunt. Stalk about an inch long, stoutish, obliquely inserted without any depression. Flesh white, delicate, buttery and melting, very juicy, rich, and vinous, exceedingly pleasant to eat, greatly resembling in texture the well-known Marie Louise. This we welcome as a valuable addition, and congratulate the raiser on his success. We believe it will be sent out by Messrs. J. C. Wheeler & Son, of Gloucester.

THE DODDERS.

LAST week the Dodder plant was found growing luxuriantly on the Hop, in this parish (Lamberhurst). It appeared to me to be the same variety that attacks the Clover. I am not aware that the Dodder has been found before as a parasite on the Hop, and there has been no Clover near the field in question for some years.—W. C. MORLAND.

[We have received another query relative to the Dodder, our correspondent asking, "Is there more than one kind of Dodder, or is the Dodder which I have had on my Parsnip crop here (Jersey), the same Dodder that attacks the Clover?" So far from there being only one, there are at least fifty known species of Dodder, *Cuscuta* of botanists, and all of them have been well described as "plants like fine, closely-entwined, wet catgut." The following is one of the more recently discovered:—

Cuscuta Californica, raised from seeds received from Mr. Hartweg, and said to be collected in fields near Sonoma, in California. This little parasite clings by its delicate thready stems to any branch or leaf within its reach. Its minute flowers are at first in close heads, but as it grows older they separate, and eventually form short loose racemes; their colour is white, and their smell very agreeable. Although Professor Choisy regards it as a true Dodder, it probably ought to con-

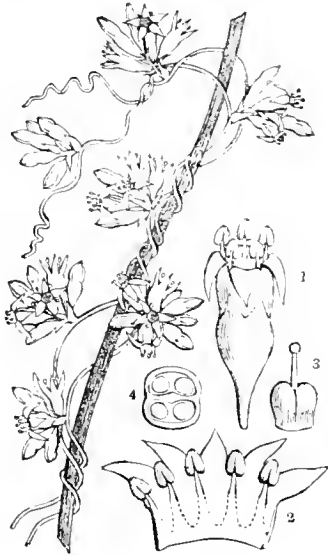

stitute a new genus; for it has but one style, the peculiar scales within the corolla of the genuine *Cuscutas* are deficient, and the upper part of the flowerstalk is fleshy and transparent. In the accompanying cut—1, represents a flower magnified; 2, a corolla laid open; 3, a pistil; and 4, a cross section of the ovary. The seeds should be sown along with those of some soft-

stemmed annual in pots; and when strong enough, and before it destroys the annual plant which it first grew upon, some softwooded shrub, such as *Lotus Jacobæa*, or *Pelargonium*, should be brought within its reach; it will soon adhere and grow freely upon it.

It is a free-blooming little parasite, more curious than ornamental.

The Dodder we have known on the Jersey Parsnips is the *Cuscuta epithymum*, or Lesser Dodder, and most frequents Furze and Heaths, but less frequently fixes on Thyme and some other plants. *Cuscuta europæa* is a much larger and more robust plant, having stout red stems, attacking especially the Flax crop, but it rarely occurs in England. Both species have been observed growing on Hop plants; and, in fact, if the seed of a Dodder be sown near any softwooded plants it will attach to them, and the juices of the Dodder partake in some degree of the qualities of the plants on which it is parasitical. The common name is thus explained in our "Wild Flowers of Great Britain:—"

"Dodder, the most common name in England, is derived from the Dutch and German name for the plant, *Dodern* or *Todern*. *Dodd* signifying a bunch; and *dot*, a tangled thread. Its ancient British name, *Cwlm y cadd*, tangle upon wood, and the French name *Goute de Lin*, a bit of flax, all refer to the form of the plant, which old Turner well describes as 'lyke a red harpe stryng, and it wydeth about herbes, folding much about them.' It is so destructive to the plants upon the saps of which it lives, that it has received the local names of Devil's-guts and Hell-weed."

WORK FOR THE WEEK.

KITCHEN GARDEN.

LET all *Asparagus* be cut down as soon as decaying, and the surface of the beds dragged off into the alleys with a rough rake or fork. The beds may have a slight salting at once, and decayed manure may be wheeled on them and spread as soon as an opportunity occurs. Pot and prick out sufficient *Cauliflower* plants immediately. A considerable quantity of *Endive* should be tied forthwith, in order to avoid any check to the heart through early frosts. All spare frames and pits should be taken advantage of. If they covered Melons or Cucumbers the haulm may be removed, and the strong *Endive*, half blanched, may be planted with good balls of earth as thickly as they can stand by each other. Do not, however, water them; if the soil is dry, so much the better. Make provision for protecting in frosty nights *Kidney Beans* in full bearing; their season may sometimes be prolonged for some weeks by averting a single night's frost. Continue to secure plenty of the August-sown *Lettuces*; an old frame or pit should be filled with the latest sowing. They may be pricked out as thickly as they can stand by each other, choosing small and compact plants. Let autumn *Lettuce* be tied up to blanch as soon as ready. Go over the *Sorrel*, and cut down all overgrown plants, to provide young leaves for winter supply.

FRUIT GARDEN.

The general impression among practical men is that autumn planting is superior to spring planting, and as an advocate of the former I would advise those who intend making new orchards, removing large fruit trees, or replacing decayed young ones, to commence preparatory operations immediately. In the first place secure fresh, sound loam, and if it can be obtained with some rough turf in it, so much the better; if not, it will do to mix rough stable litter, straw, or any other coarse material with the loam when filling it into the holes. The loam being provided, and thrown into a high and sharp ridge in order to throw off the rains, the next proceeding is to thoroughly drain the site intended for planting; without this all subsequent operations will only end in disappointment. Stations may then be formed by making a bottom of broken stone rubble, broken bricks, or other hard materials, placing a coating of cinders on this hard surface to prevent the soil from entering the porous materials beneath. As to depth, great moderation is advisable if the kinds are in any way tender and designed for the dwarfing system. For such, 18 inches in depth of soil will be sufficient, and if the ground is of a moist character, one-third of the bulk of soil should rise above the ordinary ground level; indeed, in all cases it is well to raise it considerably. A trench should be thrown out without delay round very large trees intended for removal. This will at once check late growth, and induce a disposition to produce fibres.

FLOWER GARDEN.

Trim and dress frequently during the decline of the season. Look well after choice seeds. Dablias should be earthed-up round the stems to preserve the crown of the root should any frost suddenly come. In consequence of the fine autumn a good quantity of seed will be gathered; choose a fine day, and cut that which is ripe: it may be gradually dried. Anriculas will require more attention now. Raise the frames on bricks, keep the lights off as much as possible, but always draw them over the plants in heavy or continuous rain. Plant offsets of Tulips as quickly as possible, and make preparations for planting the best beds towards the latter part of the month. All soft or diseased bulbs had better be planted forthwith. I fear many fine seedlings have been seriously thrown back, and in some instances wholly lost, by last season's blight, frost, and mildew. If the beds of Pansies for next year's blooming are not already made, lose no time in putting the plants out, that they may be established before frost comes. Take off all rooted layers of Carnations and Picotees, pot them in half-pint or pint pots, and place them in a frame for ten days.

GREENHOUSE AND CONSERVATORY.

Much has to be done in these and the other plant houses for the next fortnight. All pots should be washed clean and all insects extirpated. Should any plants prove so foul that some time must elapse before they can be thoroughly cleaned, they had better be removed to the plant hospital or some of the other houses where they will be out of sight and can do no mischief. Everything must now be made thoroughly clean, if success is to be obtained through the dull winter months. Above all things let the glass, both roof and sides, be washed; those who are unfortunately scant of labour cannot accomplish this, but the difference in point of success between a dirty roof and a clean one will be found enormous, all other matters being equal. Let everything liable to suffer from frost be housed immediately. A single night's frost will render nugatory the labour of many months. The tall Cacti should by this time have completed their growth; it is good plan to remove the terminal point from such as are still growing, and to diminish the supply of water; indeed, they will need very little, if any, between the end of October and January. Let them have abundance of light, which is of paramount importance in securing good bloom. Whatever watering may be necessary should be done early in the day, so as to allow of getting the superfluous moisture dried-up before night, for there is much more danger from damp among plants in flower at this season than from frost. Preserve a rather low temperature; and on cold, dull, cloudy days it will be advisable to use a little fire heat with air, so as to secure a moderately dry state of the atmosphere before night. Use fire heat very sparingly, however, and only when it may be necessary to prevent injury from damp, or to keep the temperature from falling below 40°. Where plants have been brought from warmer houses it will hardly be safe to allow the night temperature to average below 45°, but in houses containing a mixed collection of plants there is more danger to be apprehended from a high night temperature than from keeping it somewhat lower than may be suitable for some of the inmates.

STOVE.

The temperature of this house must, of course, decline with the decline of the year; as light is restricted, so, too, must be the heat. Continue to remove to a cooler house with less atmospheric moisture all Orchids which have thoroughly ripened their growths. The Cattleyas, when rooting freely, will continue to sprout buds from the base of the pseudo-bulbs if kept in constant excitement; this, although it increases the volume of the plant, robs the blossom. The *Aërides*, *Dendrobiums*, &c., will continue to enjoy a tolerable amount of both heat and moisture. In the growing or warmest house let 80° by day and 70° by night be the maximum for a week or two; for the other at rest, 65° by day and 60° by night will be sufficient.

FORCING FIT.

Frost may shortly be expected, and the pleasure ground and flower garden will then be stripped of its gay colours; how to preserve and encourage in doors a constant succession of flowers during the dull winter months becomes, therefore, an important consideration at this period. Part of this business may be accomplished by retarding autumn flowers, and part by genuine forcing. Success in the latter, it is well known, depends in no small degree on eligibility of the plants selected, as well as on the condition of the stock at the end of autumn. All plants intended for this purpose should have undergone a

preparatory course for weeks, nay for months, previous. An equally important concern is to provide a proper house or pit. In such a place three or four principles are of the greatest importance, and must be duly secured—viz., a sufficiency of atmospheric heat, a steady and permanent bottom heat of, as near as possible, 75°, plenty of atmospheric moisture at command, and abundance of light; in addition, a night covering would be a great acquisition. Those who cannot command such a perfect structure may resort to a pit heated by fermenting materials, the best and most enduring of which are tree leaves, more especially those of the Oak. Two-thirds of these, fresh from the trees, mixed with one-third of last year's stock in a half-perished state, and trodden firmly to the depth of 4 feet or more, will make a gradual and enduring warmth. A coating of tan may be placed over it for plunging. Some structure of this kind should be prepared as soon as fresh leaves can be obtained.—W. KEANE.

DOINGS OF THE LAST WEEK.

ANOTHER sunny week, but trying to most things not fully established. All the water we saved from the rains has been used-up for nearly a week, and but for the cooler, longer, and dewy nights we should be feeling very much the want of water. Partly owing to the heat and the dryness, we have been visited with clouds of *flies*. On the afternoon of the 28th ult. the air was filled with them. We could scarcely move without being covered, and eyes, mouth, and nostrils getting their share. On some places they formed large clusters like bees. The flies were about half the size of the common house fly, and brownish in colour. They have been more scanty since, though there were plenty of gnats and ephemeral flies that enjoyed their short existence in the sunbeams. It appeared, too, that in the afternoon numbers of the small greenish fly that have plastered the leaves of Turnips and Cabbages, rose on the wing for short periods. Altogether one might have supposed we were going to be visited with one of the plagues of Egypt. Every day we are reminded how dependant we are, and how even the most minute organisms and the smallest insects may render nugatory all our efforts. How soon the red spider and the green fly would, if left to themselves, leave little but a wreck in our vinerics and Cucumber houses! This season good fields of Turnips have here been the exception, not the rule; and even some of the best of these fields, after passing through the ordeal of possible attacks from the Turnip beetle and growing rapidly, considering the dry season, are now next to destroyed by whole clouds of a small greenish fly plastering the leaves. Caterpillars and a similar fly are causing sad havoc in the gardens in the neighbourhood, attacking everything of the Cabbage tribe and leaving little but weeks behind. A cottager told us lately that they had much reason to be grateful for the fine crops of early Potatoes, as they would be very expensive to purchase soon, owing to the devastations of the fly among the Greens of all sorts that would have helped in winter.

KITCHEN GARDEN.

Cabbages.—As already stated, we have scarcely suffered at all from caterpillars. Scotch Kale, Savoys, Brussels Sprouts, and Cauliflowers scarcely present a hole as marking where they had been present. All these, too, have escaped this little fly, though here and there patches are to be found. It has been worst on the young Cabbages just planted out and beginning to grow. The little point of growth in the heart and the smaller leaves round it would be covered with the flies, and these, if left to themselves, would soon suck out all the juices, and if the plant lived at all, it would either grow without a heart, or send up from the base two or three heads instead of one, and thus retard the time of cutting for use. By dusting, squeezing, and syringing with clear soot and lime water, we thought we had got rid of the intruders, but we find that others have come and taken their place. This week, too, many of the stumps of the Cabbages that were planted in the autumn of 1869, and which were looking so well, are becoming covered with these insects, and if let alone and no heavy rains come, they will soon be in as bad a plight as some of our best Turnip fields. We find that sewage water, if clear and not too strong, not only kills them but prevents them from coming. Even on young Cabbages it is quite as effectual as clear soot water. Fine soot is very good as a slight sprinkling. Neither that, however, nor the sewage water over the top or leaves would do where the vegetable was to be used soon afterwards.

It is always well to be learning even in little things, for, like

little insects, they may become of great importance. We have had no occasion to net from birds, game, mice, or rats seeds committed to the ground, since we dusted them with red lead. The most singular fact is, that hardly ever is a hole made to find out what like the seeds are. The instinct of the intruders seems to say to them, It would be dangerous even to hole the soil. So in the present case, could we do it without being uncomfortable to ourselves, we have a strong growing conviction that strong unpleasant scents would greatly deter our insect enemies from visiting us in their various transformations. It is often possible to secure a scent that would be distasteful to them and yet be encouraging to vegetation, such as placing strong soot water or other ammoniacal water in the evaporating pans of bothouses. The fumes of sulphur are as distasteful to many insects as they are to man, and if not presented too hot will do little injury to plants. We shall use the garden engine with not the most pleasant waters on our old Cabbage quarters, as we have enough to keep us going elsewhere until a cleansing rain shall come.

Potatoes should now be mostly out of the ground; and, especially where they are, owing to the dryness, taking a second growth at the roots, and are sending out fresh tubers from the old ones. The other day we saw young Potatoes as big as walnuts, some even as large as eggs, coming from the regular tubers, and these even not over-ripe. In all such cases the young tubers are waxy and watery, and the older ones are rendered hard and often stringy. It is best to take them up whenever this tendency manifests itself, as there can be no question the crop is otherwise greatly deteriorated in quality. In a few limited cases such an unfortunate occurrence may be turned to a beneficial result. For instance, we had lately sent to us a Potato plant of a late white kidney variety with seven or eight nice-sized tubers attached to it, and from each tuber there had come from one to three tubers from the size of marbles to that of walnuts. There were some six rows of 40 feet in length in this condition. As young Potatoes always brought a good price, especially after February, we advised to let them alone, merely giving them an earthing-up, removing the haulm as soon as it decayed, and covering the rows over with litter to exclude frost, and to dig out in spring for the new Potatoes. For private use such tubers, as now waxy Potatoes, could come in before Christmas, but old gardeners know that it is of little use to tempt with such things as early Potatoes until after the new year, or even till after parliament has met. Of course such Potatoes might not be so good as those grown during most of the winter in pits and frames, but having tried the plan several times they are very passable, and we should think much better than the old Potatoes which, it is said, are sometimes brushed and scrubbed to get the skin off, to look as if they were new and early. Our Potatoes have long been up; but if we had a few rows similar to those alluded to, we would have been tempted to let them remain in the ground until after the new year. In a similar case long ago we lifted the Potatoes in November, and put all the new growths in dry sand, and thus kept them until needed, but we did not think they were so good and sweet as those left as above on the plants during the winter. We thought them quite as good as the produce of Potatoes kept back and planted in the month of July. Of course it is only in a peculiar season that the tubers of the Potato put thus out the second growth of young tubers. Where the quality of the crop is considered the second growth should be avoided by lifting the crop earlier. There are still good breadths of Potatoes in the ground, and, less or more, these are attended with this second growth.

See last week's notes as to pricking-out Lettuces, Cauliflower, &c., and transplanting Lettuces half grown to where protection could be given to them. Sowed the last piece of Ruishees in an earth pit, so that a little protection can be given them if necessary by the end of the month. Forked in a dressing of lime in the ground intended for Cauliflower glasses, so as by frequent forkings to get all slimy enemies away. Earthed-up at once part of a Celery bed, it having been tied some time, and after watering with sewage, put a couple of inches or so of earth on some other beds to prevent the moisture escaping, except through the leaves, which it has done very rapidly of late. Before earthing-up, and as ashes at present are scarce, we strewed powdered lime over the bed, and threw it against the stems of the plants below the leaves, whilst these stems were damp with dew. This, as well as a little dusting of soot, will keep worms and slugs from rising and disfiguring the foot-stalks of the leaves. We have seen no grub in the Celery leaves this season, and we attribute that chiefly to the fact that the

little water we could give was from the house sewage, and to a slight sprinkling of soot over the foliage, which we think helped to deter the fly from depositing its eggs. Where the grub mines between the two skins of the leaf, and makes it alike a comfortable home and a rich dining place, there is no means of touching it there, and the only remedy is to crush and kill, or pick off the infested leaves and burn them. The Celery tied some weeks ago is now pretty well blanched at the centre. The tying also induces the centre to rise. As lately stated, much of our Celery has not been long planted, as we could not have watered it, but the plants were large, and with large balls, so that even for a day they scarcely felt the moving, and will come in before the earliest ones are used up. Thanks to shading, &c., though we could scarcely give any water, we do not notice a trace of a bolted head.

FRUIT DEPARTMENT.

Strawberries in pots for forcing we moved, so as to give more room to the large foliage, and thus help the ripening of the buds. Owing to the dryness we could not obtain early runners, but now the most of the plants are quite large enough to our taste. In moving, every vestige of a weed and runner was removed. No autumn could be more favourable for such plants, the bright sun beaming on them, and not a shower for more than a fortnight. By this time we have often had to turn the pots on their sides to prevent their being incessantly deluged. When such rains come in October, or the end of September, it would be well for the plants if we could take them under glass, so as to have an abundance of light and plenty of air. Few of us, however, are able to give them such good quarters. We have no doubt that many fine plants are injured by their being constantly wet, or when the pots are laid on their sides and are then struck with a sudden sharp frost, which affects the plants more than when the pot stood upright, as then the leaves would so far be a protection. We are quite convinced that many a plant that goes blind in the forcing house would have fruited but for the bad treatment it had in the autumn and early winter months. A plant exposed in a pit has a hard time amid changes of weather, temperature, &c., as compared with a similar plant growing in the open ground. It is difficult to know at times, with limited means, what to do with them. In the beginning of last winter we packed a great many pots with dry leaves in an earth pit covered with old sashes, leaving the tops of the plants exposed, and no place could have suited better, but the grass mice and rats were attracted by the mere protection, and, in spite of every scheme we could think of, they cleared out the buds of some hundreds of our best plants, whilst we do not think they ate a single bud of the plants growing in the ground out of doors.

Partly taught by the above circumstance, and partly owing to the wish not to have so many pots filled with Strawberry plants, thus saving the attention and labour requisite, we generally about this time turn out a good number of young plants into a piece of ground which has been well exposed to the air and enriched on the surface, planting them 6 or 7 inches apart, and raising them if we should want them in spring. Good runners planted out in September do very well for this purpose, but they do rather better, and are more easily managed, if before this planting-out they have made a little ball of roots in a small 60-sized pot. When planted out the fresh roots keep closer together, and the plants lift better for frames, pits, and for potting in spring. These do very well for the last crops in-doors when taken up about the end of March or the beginning of April. For all early work it is necessary that the pots should be crammed with fine healthy roots in September; in other words, that the plants be fully established in the pots before resting in the beginning of winter.

Proceeded with *gathering Apples and Pears*, and on the whole find them individually larger than we expected they would be. They swelled very much after the showers came, and now the bright sun is giving them a good colour. It is such a loss when good fruit drops; it seldom keeps any time, and always shows the blemish when cut or peeled. It is well to keep all fallen fruit by itself for earlier use. Such a plan would lessen the labour in a fruit room, where only the best fruit is placed. It is of little use storing up inferior fruit, which will have again to be shortly removed as useless. A few Pears on bushes are a little spotted this season, and housing what would not do even for stewing is of little use. Talking of stewing, a friend of ours mentioned the other day that the fine old stewing Pears seemed to be quite at a discount, which may be owing to the fact that our very best Pears when used when hard, before they begin to be the least mellow, turn out also the best when stewed.

Pine Apples grown by fermenting material should now have the linings well banked up, so that plenty of air may be given without lowering the temperature. Where fire heat is used there will be less difficulty. Those swelling will require a moist high temperature and more air as they approach ripening. Those intended for fruiting in spring should slightly rest, from having less water.

Late Melons must have a good temperature to swell them off, and if in frames will need the linings to be turned and banked up to the top of the frame. The same will apply to Cucumbers. Our first spring Cucumbers in a pit still keep on so well that we decline taking them out as yet, and, therefore, have turned out strong plants in a pit to give a late supply, and we will grow on in pots others to be turned out as large plants a month or six weeks hence, when the first alluded to are bearing. Winter Cucumbers, allowed to bear freely before Christmas, do not often bear freely afterwards.

Late Vines with the roots in borders out of doors will be the better of plenty of sun, but if heavy rains come they will do better if protected. Sashes raised above the ground would be best, waterproof cloth or shutters would be the next best. A makeshift may be made with rough covering, or roughly thatching with dry litter. See what was lately said about early-autumn planting. Vines, if the roots are protected from frost and wet, need be no exception to other deciduous plants. Early Peach houses may now be stripped of the leaves as soon as they ripen. If there is any spider or scale, it is advisable to syringe them well with soft-soap water, and clear soot and sulphur water. When clearing it is well to scrape off the surface soil, and to water through a rose with water near the boiling point, if the nearest roots are from 2 to 4 inches from the surface. The water will be cooled before reaching the roots, whilst any insects or eggs near the surface will be destroyed. Before colouring walls it is well to wash or syringe them and all woodwork freely with the hottest water. Every chink and cranny is apt to be a depository for insects and their eggs, and a little care in the way of prevention will always be better than getting rid of them when the crops are growing.

ORNAMENTAL DEPARTMENT.

The flower garden is still fine. Verbena beds are again, after recovering since the rains, feeling once more this sunny fortnight. Where water is as scarce as with us we would not advise planting many Verbenas. Ours were very good and most useful for cut flowers before the drought came, and then no mulching, &c., could keep them vigorous. A good watering once or twice a-week would have preserved them in health and bloom, but that we could not give them. All the varieties of Geraniums stood the weather well. We have had better beds during the season, but perhaps the best we have now after the second drought are two companion beds of Punch, which are one mass of brilliancy, and could scarcely have been excelled in the middle of August. Rubens, a favourite pink of ours for autumn, is good still, but some of the petals are bleached a little by the slight frosty mornings; as yet, however, we have suffered little. Even Calceolarias, passable in June, have rich masses of colour. To keep the beds somewhat in character we have cleared off the leaves of deciduous trees which had fallen, so far marring the effects of the flowers and rich green lawns, though in a few places feeling the effects of this bright weather. We shall not yet think of moving anything from the beds. We are still busy propagating, giving the cuttings a little heat. The first-put-in are hardening-off, and the intermediate ones have had the shading removed. We would give little shade to flower-garden cuttings if we had clean water to give more frequent dustings overhead from the syringe. From reasons previously detailed, taking small cuttings involves a little more care than if they were larger. We gave manure water to Salvias, Chrysanthemums, Geraniums, and large-flowering Pelargoniums intended for late blooming in pots, and kept potting and repotting Cinerarias and Primulas. We shall have some trouble with Violets, as from the dryness they were much infested with red spider in summer; Neapolitans suffered most. They are becoming better now from syringing. Plenty of flowers are coming on others, single and double.—R. F.

TRADE CATALOGUE RECEIVED.

W. Clibran & Son, Millbank Nursery, Warrington.—Catalogue of Dutch Flowering Roots, Roses, Pelargoniums, &c.

TO CORRESPONDENTS.

* * We request that no one will write privately to any of the correspondents of the "Journal of Horticulture, Cottage Gardener, and Country Gentleman." By doing so they are subjected to unjustifiable trouble and expense. All communications should therefore be addressed solely to *The Editors of the Journal of Horticulture, &c.*, 171, Fleet Street, London, E.C.

We also request that correspondents will not mix up on the same sheet questions relating to Gardening and those on Poultry and Bee subjects, if they expect to get them answered promptly and conveniently, but write them on separate communications. Also never to send more than two or three questions at once.

N.B.—Many questions must remain unanswered until next week.

BOOKS (R. F. Y.).—We never saw a separate copy of Abercrombie's "Seed Estimate." It was appended to one of his larger works, and they are long out of print, except his "Pocket Journal" and "Every Man His Own Gardener."

NATURAL ROCKS (J. E. W.).—We do not know of a vendor anywhere.

HEATING BY GAS (P. S.).—Procure No. 341 of this Journal. You will find in it engravings of gas stoves. If the house is large it will be more economical to have hot water or a flue, in the absence of definite information as to dimensions, &c., it is impossible to advise.

WHITE DOUBLE GERANIUM (H. Rising).—We have heard of but not seen one.

MARKETING FRUIT (F. P. G.).—If the fruit is of such good quality as you state, apply to Messrs. Webber & Co., Central Avenue, Covent Garden Market, London. As you live so far from town, the cost of carriage may render it more remunerative to dispose of your surplus produce in some market near home. The problem which you propose—to dispose of produce to the best advantage—is one which admits of a variety of solutions according to circumstances.

LAWN SAND (A. C.).—We know nothing about the article, and feel certain that no application which will destroy weeds will at the same time benefit the grass.

PRIVET EDGING (W. R. H.).—Privet would no doubt grow, but we think it would not be easily restrained even by the shears. We have, however, seen it kept neat at a height of 1½ to 2 feet, but that is much too high for an edging. Have you tried Ivy? We have seen it used with good effect. The small creeping kind of the woods is best.

PRUNING VINES (Young Beginner).—We have no fear of the mode of pruning you have been advised to adopt answering well, but we do not think it necessary with Vines so young as yours are; and the bunches from the large eyes, though larger, are often loose, and for many other reasons are not equal to those shown by the eyes at the base of the shoots; besides, you will have shoots that must crowd and interfere with the bearing shoots, therefore we should prune to two eyes, and, rather than have another shoot several inches above it, we would let one of the two shoots that come from the eyes be for wood, and the other for fruit. But even that is needless. One good shoot is enough for each spur, and retain as many spurs as can have proper exposure to light and air. It often happens when the system of pruning advised is adopted, that the eye left to form wood for another year's bearing does not break, or not strongly, and you have, as a consequence, an ugly bare length of spur, which it would require nearly a dozen years to form by the other mode of pruning. Your Vines have done well this season. Would it not be prudent to let well alone? We think, however, that you crop them too heavily.

GRAPES FOR LATE-HANGING (T. H. D.).—For hanging well the Madresfield Court Muscat is unequalled. We should have at least two of it, White Lady Downe's, and Trebbiano. They do not require more heat than Lady Downe's.

VINES (J. Leonard).—If there is a succession rod to take its place, you may cut out the old rod which has borne.

GRAPES SPOTTING (Allan).—We think your Grapes are affected with the spot, and in your case it appears to be caused by syringing after fumigation; besides, we do not approve of Vines, of which the fruit is not ripe, being kept without water for the last two months. That would cause them to go off as you describe when the weather became moister. The border ought to have had a good watering within the last fortnight, for in a dry border Muscats do not ripen well; indeed, to do them justice they require a good deep border, and an abundance of moisture while swelling the fruit.

HEATING A VINE BORDER (A. Clapham).—We should think that three 5-inch pipes would be ample. The size of your chamber is of less consequence than having the pipes not far from the covering, whether of stout slate or flagstone from 1 to 2 inches thick. At page 251, second column, you would see how you might rough-chamber such a place with clinkers or brickbats, but not covering the pipes deeply, and then have some fine gravel on the top. On that over the chamber you would require from 10 to 25 inches of good soil, and a fourth of equal parts of lime rubbish, bruised hoiled bones, and a little half-rotted manure well aired and dried, so as to be free from fungus spawm. Of course, if you use four pipes in the border you will have to heat them less. We are in doubt if we quite understand your object.

VARIOUS (Amateur).—Put in some buds next July on the bare portion of the stem of your tree, or cut it back to the lower portion. Place the glass covering over your Strawberries about the beginning of the year. Get your Peach tree into better health, and treat it well. Your fruits may have dropped through dryness at the roots, or too much vigour, or various causes which we cannot even guess at. Spur-in all the side shoots on your Currant trees pretty closely, leaving a framework of five or six branches only, and stop the points to one-half their length. For Gooseberry bushes leave more young wood, but thin the centre considerably.

EXHIBITION STANDS FOR ROSES AND DAHLIAS (E. M.).—The boxes may be made of inch deal, and the length for twenty-four Roses should be 4 feet; for eighteen, 3 feet; for twelve, 2 feet 2 inches; and for six, 1 foot 6 inches. Breadth in every case 1 foot 6 inches; height at back, 6 inches; height in front, 4 inches. We extract the foregoing dimensions from the excellent "Book about the Rose," by the Rev. S. Reynolds Hole, who adds:—"The covers, being 7½ inches in depth at the back, and 5 inches in front, 4 feet 1 inch in length, 1 foot 7 inches in breadth, and having a narrow beading within the four sides, half an inch from the bottom of the lid, overlap the boxes, leaving ample room for the Roses, and are secured for travelling by stout leather straps. Within the boxes some exhibitors have laths pierced at equal distances on a uniform surface of wood; but as Roses differ in size it is more convenient to have the facility of placing them where we please, and for this purpose it is desirable to have strong laths ¾-inch in depth, and 17½ inch in width) extending the length of the box. These laths should be six in number, and should be nailed on two strong pieces of wood, crossing the box one at each end, 2 inches below the surface. The upper and lower laths should be fixed one-eighth of an inch within the box, and the four remaining so arranged that there will be five interstices 14 inch in width—three for the Roses, and two merely to reduce the weight. There will be a space of 1½ inch between the laths and the upper edge of the box, to be filled as follows: Cover the laths with sheets of brown paper, two deep, and cut to fit the box, and upon these place the best moss you can obtain. The Roses are placed in tubes of zinc 4½ inches in length, 2 inches wide at the top, gradually tapering until they become 1 inch in width at the centre, the tops being moveable. This top is taken off, and the stalk of the flower being brought through until the Rose is held securely, it is replaced upon the tubes, previously filled with pure rain water." A stand for twenty-four blooms of Dahlias should be 48 inches in length by 18 inches in width from front to back. It should be raised at the back 7 inches, and 3½ inches in front. The holes should form three lines of eight each, and should be 6 inches from centre to centre, and 3 inches from the outside. The metal tube for the water may be 1 inch in diameter, and should fit into the holes of the board; the wooden tube to receive the bloom, and fitting into the metal tube, should rise 1½ inch above the board. The colour of the board should be a lively bright green. The dimensions of a stand for twelve blooms of Dahlias can be easily deduced from the foregoing. Such a box as that just described would be suitable for Roses if shown in single trusses; for single blooms of Roses the dimensions would be almost too large, while for bunches of three trusses it would scarcely afford sufficient space. For Roses the tubes may be fastened to the bottom of the box, not using a board as in the case of Dahlias, and the spaces filled up with fresh green moss. The most suitable colour for a box for Roses is dark green. You may use several boxes in showing a number of trusses or blooms. Chapin's cases are excellent, especially where flowers have to be sent to a distance.

CLIMBING ROSES FOR HIGH WALLS (E. M. E. A.).—Those mentioned are not all of them suitable. Retain *Marchal Niel*, *Lamarque*, *Climbing Devonensis*, a shy bloomer here, but a wonderful grower, and *Gloire de Dijon*. Add *Solfaterre*, yellow; *Triomphe de Rennes*, yellow; *Mdlle. Aristide*, pale yellow; *Céline Forestier*, yellow; *La Riche*, flesh white; *Académie*, white; *Ophiré*, orange and copper; and *Jaune Desprez*, red, buff, and sulphur. These will require some room to spread, as they are vigorous growers. Those marked with an asterisk will require much room overhead and on either side. They require but little cutting. Thin rootless wood, and merely top the shoots, whether extensions or fore-shoots, to the first good eye in sound wood. I did not cut my trees of *Céline Forestier* this year, and I never saw a more magnificent bloom. The yellow Tea-scented *Noisettes*, are, in my opinion, the most satisfactory Roses of the Rose kingdom. My trees of *Triomphe de Rennes* are at this time a wonderful sight. It is about the most satisfactory of all the yellow Roses.—W. F. RADCLIFFE.

PRUNING ROSES (Agnès).—As it is very difficult for a tailor to make a suit of clothes to fit everybody, so from different circumstances it is difficult to lay down any stiff rules of pruning. As a general rule cut out all weak and useless shoots, and such as awkwardly cross the other branches. Cut weak growers hard, and leave a liberal quantity of wood and of greater length on strong growers. If you find that the shoots which you call water-shoots bloom well from the sides, you should not cut them away. Apparently immature wood on a Manetti-stocked Rose will bloom abundantly if you cut the top of the shoot off, and cause it to break from the sides of the shoots. Soft shoots from the Briar will not always do this. If you find that cutting your Manetti Roses to 6 inches answers best, it is, of course, wise to do so. If the water-shoots on your standards are necessary to form the head let them stay, and cut them next spring, or shorten them after blooming is over.—W. F. RADCLIFFE.

PANSIES FOR BLOOMING IN SUMMER (Flora).—For spring you will need to have now good plants, fit for turning out where they are to flower when the bedding plants are removed. The beds should be well dug, and a liberal quantity of leaf soil and old rotting manure dug in, mixing it well with the soil. You must not expect the plants to continue blooming from spring until autumn. For summer flowering the cuttings ought to be put in now in a warm, sheltered situation, and be planted in spring in their summer quarters; and to make them bloom finely until autumn, it will be necessary to give liberal supplies of water in dry weather, and to mulch the beds about half an inch deep with short manure, which will be hidden by the foliage. Pansies are at the best very precarious bedding plants. They cannot stand the drought and heat of summer.

WINTERING GERANIUMS (Idem).—You would best succeed in wintering them in pots in the rooms, taking up the plants before frost, and placing them in light moderately dry soil. You could then pick off the old leaves as they become yellow, and cut away the shoots that damp off. They would not require much water, if any, between the time of potting and March, though a little might be given in mild weather to keep the shoots from shrivelling. You must keep frost from the plants; if you cannot, then the cellar would be the best place, removing all but the very small leaves, and storing the plants in dry sand. Only the roots should be covered. Examine the plants occasionally, and remove any damped leaves or shoots. There is little hope of your getting the cuttings taken from the plants to strike in a room, but you can, nevertheless, try it. Put them in light sandy soil.

LILY OF THE VALLEY SEED SOWING (F. C. H.).—By sowing the seed you will obtain plants, and may be fortunate in having something new. Keep the seeds in dry sand in a cool place, and sow them next March in

light sandy soil in a partially-shaded border, and cover with a depth of light soil about equal in thickness to the diameter of the seeds. Water in dry weather. About the third year they will flower.

CLIMBERS FOR A LOW WALL IN FRONT OF A LODGE (W. Armstrong).—We think you could not do better than plant *Cotoneaster* at the base of the wall, and it will cover it very closely like a carpet. *C. microphylla* would suit you best. It will need training, so as to cover every part of the wall regularly and quickly. For the lodge front, if the sun shine on it, we advise *Pyraeantha*, but if not, we should have *Ivy*. The Irish *Ivy* is good, and so is *Raxger's*, with fine h-b-l leaves. The *Yews* will bear any amount of cutting. It is best to cut them in spring before they begin to grow, and you need not be afraid of using even the saw. They will make fine shoots before autumn. We think the end of March or early in April the best time for heading them back.

PEACHES FOR WALLS AND TRAINING (J. M.).—There is very little room for selection when three kinds only are required, and we presume you do not want them to come in together, therefore we advise *Early York*, *Grosse Mignonne*, and *Barrington*. Three others equally good are *Noblesse*, *Royal George*, and *Violette Hative*. Fan training is the most suitable for out-door culture in England, as the trees vertically trained have the shoots much less vigorous at the base than at the top; indeed the lower branches not unfrequently die off altogether, and the trees are little better than standards.

BEEF FOR SPRING GARDENING (G. H.).—For this purpose it should be planted now where it is to remain, and so that the root will be covered, otherwise it is sometimes injured by frost. The old leaves ought to be left until spring, for they protect the plant, but in March remove them. It will be in good condition until the flower-stalks begin to rise, and after that we think it more suitable for the flower garden than at any other time.

DISTINGUISHING *SILENE PENDULA* FROM *S. PENDULA ALBA* (Idem).—The red sort has a much darker stalk than the white, whilst the leaves of the plant are of a deeper green. The latter variety is altogether lighter in appearance.

SHRUBS FOR THE FRONT OF A COTTAGE (A Cottage).—We think you will not find that you can have shrubs of the height you require without considerable cutting. Hollies would be most suitable, and we would have alternately pyramids and bushes, with opposite plants to match. We should have the plants 15 feet apart, putting in the first at 7½ feet from the cottage, and the last at the same distance from the road. If you should require six trees on each side, and commencing next the cottage, we would have *Gold-leaved (bush)*, *Hodgins's (pyramid)*, *Silver-leaved (bush)*, *masaderensis (pyramid)*, *Gold-leaved (bush)*, and *Hodgins's (pyramid)*, having the other side to correspond. Their distance from the walk should be half the distance they are apart, and they should be planted on grass. The earlier they are planted the better. You can cut them to any form, and have them of any height. They are best cut in spring, just before they begin to grow. The proper time to plant wall fruit trees is in November as soon as the leaves have fallen. With regard to your other question, you will find an article on the subject in a previous page.

GARDENIA CITRIFLORA SICKLY (Saccobium).—The cause of the plants looking sickly is probably want of heat, and the soil may have become sour from the plants having too much pot-room or defective drainage. We advise you to make the drainage good, and place the plants in a light, airy position in the stove, giving no more water than enough to keep the leaves from flagging. In February give them an increase of heat with bottom heat, if possible, and we have no doubt they will begin growing freely. Pot in March, removing from the roots all the soil that comes away freely, but be careful of them, and do not place them in pots larger than will hold the roots comfortably. They need a moist atmosphere and copious supplies of water.

HYDRANGEA NOT FLOWERING (Idem).—The plant could not be expected to flower this summer, as you cut it down last spring, and in so doing removed the flowering portion, for the wood of this year gives flowers the next.

ANECTOCYLUS DAWSONIANUS SICKLY (S.).—The best treatment you can adopt is to remove the plants at once and place them in fresh soil. Use a compost of equal parts of fibrous brown peat, sphagnum chopped up, and charcoal for the bottom of the pan or pot. Let the pot be efficiently drained, press the soil firm, and then surface with equal proportions of peat, charcoal, and silver sand. Keep the compost regularly moist, avoiding wetting the foliage, and take off the bell-glass every morning, wipe it dry, and replace it. It is desirable that the bell-glass should have a hole in the top; if not, tilt it a little on one side for a few hours every day.

TUSSELAGO FARFARA VARIEGATA, ALTERNANTHERA LINDENI, AND IRESINE AMABILIS PROPAGATION (O. W. M.).—The Tusseilago is increased by division of the roots in spring, dividing them into as many portions as there are growing parts, with some stem and roots to each. It is quite hardy, and likes strong, deep loam. The *Alternanthera* is increased by cuttings, which strike as freely as *Verbenas* in sand in a hotbed. The best plan is to strike cuttings now, wintering them in a warm greenhouse or cool stove. They will produce plenty of cuttings in February or March, and these, if forwarded in a hotbed, make good plants. *Iresine* is propagated in the same way, cuttings rooting very freely in a hotbed. *Alternanthera magnifica* has fine reddish bronze leaves, and is, like all the *Alternantheras*, useful for bedding out. It is raised like *Verbenas*, only it requires to be wintered in a warm house. You may increase them to a considerable extent by keeping them in heat.

EVERGREENS FOR TUBS (F. R. G.).—All things considered, we advise *Portugal Laurel*, *Laurustinus*, and *Hollies*, with *Sweet Bays* if the situation be mild. Handsome flowering evergreens will not succeed in tubs. We would have matched plants, two of each, and pyramid *Portugal Laurels*, *Gold or Silver-variegated Hollies*, and *Laurustinus*. They stand cutting well, and when in good foliage are very fine. You may select plants at most of the leading nurseries. We do not recommend dealers. Good plants of *Yucca recurva* are fine for tubs. They have a very distinct appearance.

APHIS ON BROCCOLI AND WINTER GREENS (J. B. S.).—The cabbage-plant louse (*Aphis brassicæ*) is making sad havoc in many places in the north, whole fields of Turnips being cleared off by them. We have it, and have tried lime, but without effect, the plague only comes on by

degrees. We do not think soot would be of any use. If we could obtain it we should use the ammoniacal liquid from the gas-works, sprinkling the plants all over, so as to wet every part; and if it were possible we would supplement with a drenching of liquid manure between the rows. With us the parents fly about in clouds, settling on the leaves they deposit their eggs, and the young soon hatch. We have had more insects this year than we ever remember.

PLANTS FOR CONSERVATORY (J. R.).—We should advise you to commence with a few of the commonest plants, which are, nevertheless, good:—*Acacia armata*, *A. oleifolia elegans*, *A. pulchella*, *A. magnifica*, *Chamaerops excelsa*, *Conozoma cordatum splendens*, *Citrus Aurantium* (Orange), *Cytisus racemosus*, *Dracena australis*, *Habrothamnus elegans*, *Hydrangea japonica* and var. *variegata*, *Kalosanthes coccinea superba*, *Myrtus communis* (Myrtle), *Nerium rubrum plenum*, *Polygala Dalmaisiana*, *Rhododendron javanicum*, *Princess Royal*, *Princess Alexandra*, *Jasminiflorum*, and *Vallota purpurea*. *Camellias* you may add advantageously as you feel disposed, also *Azaleas*, with *Primulas*, *Cyclamens*, *Cinerarias*, and *Calceolarias* you may have a nice show. We cannot account for the *Balsams* and *Primulas* failing. Much depends on the treatment.

HEATHS (Jay Cec).—Do not apply the liquid manure. If potted in fitting soil they will only require a regular supply of water.

SEEDLING HOLLYHOCK (Westmoreland).—Quite smashed. It should have been sent boxed in damp moss.

SEEDLING POTATO (W. Thomson).—The samples you sent us of the seedling you have named "Favourite," were mealy and well flavoured when boiled. The tubers were middle-sized, flattish-oval, eyes few and not deeply sunk, skin rough. They seem to be akin to the Forty-fold.

RAISING SUBTROPICAL PLANTS (A Subscriber).—Canas will succeed by both the modes you name—first, by securing the roots when they are taken up, and storing in sand in a collar, potting in March, and forwarding in a hothed; second, by sowing in a hothed in February, forwarding, and hardening well off before planting out. *Wignandia caracasana* is propagated by cuttings of the roots in a hothed in spring, and best by cuttings of the shoots. *Ferdinandia eminens* is also propagated from cuttings either at the end of summer or in spring. *Polymnia grandis* is increased by cuttings of the old plants placed in heat in spring, the cuttings being inserted in a brisk bottom heat. *Nicotiana*, or Tobacco, is raised from seed sown in light soil in a hothed in March, pricking off when large enough, growing in heat, and hardening off before planting out. The *Alternantheras* are propagated from cuttings put in new, or better in spring, in light soil, and placed in a hothed. All succeed in a light fibrous loam, with one-third leaf soil or well-rotted manure.

YOUNG FOREST TREES OVERGROWN WITH GRASS (Lieut. Col. H.).—If your communication had reached us two months earlier, we should have had no hesitation in advising you to clear the ground of all herbage; but now, as autumn is set in, we are afraid there is some truth in the popular notion of which you speak—that long, rank grass and other weeds afford shelter to the young trees; this they unquestionably do, but there are very few cases indeed in which the trees could do better without such shelter, if it were removed early in the summer, so that the young trees would become well hardened by gradual exposure to the autumn colds, so as to withstand the storms of winter. In your case we should be inclined to wait till spring, and then clear everything away, but not carrying anything off the ground. Assuming the trees to be 2 feet high and 4 feet apart, we would remove the long grass and weeds to the distance of a foot or more all round the collar of each plant, with a hoe or something of that kind, but not penetrating the ground so deeply as to injure the tree roots. We would leave the rubbish in heaps between as to injure the tree roots. We would leave the rubbish in heaps between as to injure the tree roots. We would leave the rubbish in heaps between as to injure the tree roots. In summer a few hoings in suitable weather will preserve neatness. Not knowing the character of the soil and other particulars of your case we can give no opinion of the soil and other particulars, but if it is damp and boggy, or even consists of dry peaty soil, Beech trees, which you speak of as forming part of the plantation, are the most insupportable of any, as that tree likes a chalky or dry stony soil. Where large breadths of moorland are planted without undergoing any preparation, merely planting on the thick grassy or mossy sward, it is good practice to clear the rubbish away with a hoe or something of that kind, once at least early in summer, leaving the later growth to form that natural shelter for winter, which, after all, is not without its advantages.

APPLES GRAFTED ON FRENCH PARADISE STOCKS (L. & W.).—The French Paradise stocks are employed by Messrs. Rivers, Sawbridgeworth, but not recommended, because they require a warm, generous soil and climate. They form very dwarf trees, but not of greater fertility than the best dwarf English Paradise—the Nonesuch, of which trees were exhibited at South Kensington on Wednesday last. These trees were 18 inches or so in height, two and three years old, and full of fruit. Some Apple trees on the French Paradise at Sawbridgeworth are from ten to twelve years old, and not more than 18 inches high. They are full of fruit. They have been lifted twice or thrice. Some of the trees are affected with canker, the great fault of this stock. On the Nonesuch Paradise, trees of the same age, and under the same treatment, are about 2 feet in height. They are equally loaded with fruit, and free from canker.

TREES FOR A SLOPING LAWN (Leadbeater).—We presume you would require principally evergreens with a few deciduous trees. Of trees proper, we would have Purple Beech, both the common Horse Chestnut and the pink, the Weeping Birch, the Elm, the Lime, the Fern-leaved Beech, the scarlet Oak, the variegated Sycamore, and the scarlet Maple. These we should place as near the outside as practicable. Then you will need the Mountain Ash, Stag's-horn Sumach, double pink, scarlet, and white Thorns, with the double Cherry, and Siberian Crab. Of evergreens we should have *Picea Nordmanniana*, *P. nobilis grandis*, *P. Pissapo*; *Cupressus Lawsoniana*, *Pinus Combra*, *P. excelsa*, *P. austriaca*, *Thuja Lobbi*, *Thujopsis borealis*, the American and Chinese *Ahor-Vite*, *Cedrus Deodara*, and *C. Libani*, with *Hollies*—Gold and Silver-variegated, *Hodgkins's*, and *altacerensis*—*Portugal Laurels*, Irish and common *Yew*. These well arranged would have a fine effect.

GARIBALDI STRAWBERRY (W. Thomson).—It is evident that you had Vicomtesse Horticulteur de Thury sent you. As for verifying the merits of new varieties, the editor who undertakes such a task would be a very unwise man.

POTATO (H. S. Cornuby).—We cannot profess to name Potatoes from a single example. Most probably it is a mere local variety.

APPLE JACQUES LEBEL (R. D.).—It is described in Downing's "Fruits and Fruit Trees of America" as being of much beauty, but of ordinary quality. "Fruit large, roundish oblate, lemon yellow, shaded with red in the sun, many grey dots. Stalk large. Cavity deep. Calyx half closed. Flesh white, tender, mild, subacid."

NAMES OF FRUITS (Richard Taylor).—No. 1, which you bought for Glou Morgean, is *Beurre de Capiaumont*; 2, *No plus Meuris*, we believe is simply the stock; 3, *Easter Beurre*, we believe is *Duc de Nemours*; 5, *Keswick Godlin*, is correct. (*H. L.*)—We believe the Crab is the *Yellow Siberian*; 2, the pale Apple is most likely a local kind; it resembles *Broad-eyed Pippin*; 3 is *Braddick's Nonpareil*. *Munche's Pippin* is not a synonym of *Margil*. (*W. W.*)—*Plum*: 11, *Coe's Golden Drop*. *Apples*: 1, *Court of Wick*; 2, *Winter Gold Pearmain*; 7, *Constanza*; 10, *Hawthornden*. *Pears*: 5, *Beurre de Capiaumont*; 8, *Easter Beurre*; 9, *Vicar of Winkfield*; 12, *Louise Bonne de Jersey*. (*Rev. H. H. Dombtrain*).—*Pears*: 1, *Comte de Lamy*; 2, *Beurre de Capiaumont*; 3, *Beurre diel*; 4, *Marie Louise*; 5, *Forelle*; 6, *Napoleon*. *Apples*: 2, *Wesh Pippin*; 3 and 9, *London Pippin*; 4, *Alfriston*; 5, *Royal Russet*; 8, *French Godlin*; 10, *Probably French Crab*; 11, *Ribston Pippin*; 12, *Hawthornden*; 13, *Like Biswingwood Russet*; 15, *King of the Pippins*; 16, *Aibans*; 17, *Yellow Inglesrie*. (*T. G. Bedford*).—*Empereur Alexander*. (*T. J. Herbs*).—*Apples*: 1 and 1, *Fearn's Pippin*; 2, *Hollandbury*; 3, *King of the Pippins*; 15, *Dumelow's Seedling*; 19, *Alfriston*; 18, *Rymer*; 20, *Blenheim Pippin*. *Pears*: 2, 4, *Winter Nohis*; 1, *Marie Louise*. *Peaches* cannot be named without the flowers and leaves. These were much confused, and several without numbers. Do not stick numbers on with pins. (*Without Name*).—*Apple*: *Longville's Kernel*; 14, *Court of Wick*. *Pears*: 20, *Althorp Crassane*; 62, *Hacon's* incomparable; 50, rotten. (*J. C. Bromley*).—The Bean is called the *Asparagus Runner*. The Apple we do not recognise. (*G. Birdhill*).—The Pear is *Flemish Beauty*.

NAMES OF PLANTS (A Subscriber, G. A. B.).—We cannot undertake to name florists' flowers. There are hundreds of *Geraniums*, and the only mode we can suggest of ascertaining the name is to compare it with the varieties in some good collection in your own neighbourhood. (*J. H. B.*)—Your *Fungus* is the *Fairy-ring Champignon* (*Marasmius oreades*), one of the best of edible Fungi.

POULTRY, BEE, AND PIGEON CHRONICLE.

LIABILITY OF SECRETARIES FOR THEIR MISTAKES.

I ENTERED two pens of birds for the Keighley Show, but the Secretary, Mr. R. Fawcett, never sent me labels for the hampers, consequently I was prevented showing my birds. I wrote for my entry money to be returned, but received no answer. I twice repeated my application, and threatened taking proceedings against him if the money were not returned in due course, but no notice was still taken, consequently I entered him in the County Court, where he was compelled to pay the money, together with the court expenses. I hope the above will be a lesson to others placed in a like position to myself.—JAS. GLESSALL, *Old Hall, Mithorpe*.

BIRMINGHAM POULTRY SHOW, 1870.

I FANCY that most exhibitors will agree with the remarks of Mr. L. Wright about the schedule for the present year, especially as regards the measures necessary to lessen the number of entries. It is a great mistake, I believe, to continue the present form of subscription and entries, with six admission tickets. It is well known that there is always a large sale at Birmingham; it is known, too, that with the enormous number of entries pens have received notice from the Judges, whilst their merits perhaps scarcely deserved it. Many exhibitors doubtless enter pens on this speculation, as they have four pens to fill up; and so, if we examine the entry list, fours, or some multiple of the mystic number, are the rule.

I have in bygone years in your columns complained of the illiberality of the Birmingham Committee to the exhibitors of "Any other variety." I consider that at Birmingham there should be at least two first, second, third, and fourth prizes, say £14. This is not too much. Considering that to this class we owe the introduction of the *Brahmas*, French fowls, and other now thoroughly established favourites, and considering that at many comparatively insignificant shows an equal amount is offered, I trust another year will mark a great addition to these prizes. Is it too late for the Committee to advertise that there will be two sets of prizes at the next show?

I have often thought that *Guinea Fowl* deserve a class to themselves at Birmingham. Surely *Japanese* (*Bantams*, I presume), have a refuge in Class 80; I cannot but think that *Silkie*s ought to go there also.

A few words about the *Malay* prizes. Birmingham does still retain classes for this breed, and during the past year and this the Committee have been assisted by exhibitors. I am bound to say that this year, in forwarding the amount collected, I expressed the hope that the Committee would apportion the

amount between first and second prizes more equally, and had hoped this would have been done. I am certain that last year entries were lost on this account. I am disposed to think it will lessen my entries now. It seems now-a-days legitimate to hit the poor Malays hard; but my good friend, Mr. L. Wright, would hardly have penned his few remarks about their entries last year if he had studied the catalogue of 1869. For instance, there are some classes of Malays that paid the Committee far better than did some of the classes of other breeds! This is a monstrous thing for me to state; perfectly untrue some may probably think the statement, but let me come to chapter and verse. Class 31, Malay hens over one year, had seven entries; or let me make the following table as a comparison:—

Class and Breed.	No. of Entries.	Amount at 3s. per pen.	Prizes offered.
		£ s.	£ s.
Class 17.—Cochin (White).—Cocks over one year.	8	1 4	5 0
Class 27.—Brahma (Light).—Hens over one year.	9	1 7	5 0
Class 37.—La Flèche.—Cocks	4	0 12	4 0
Class 38.—Ditto.—Hens	5	0 15	4 0
Class 47.—Hamburgs (Silver-pencilled).—Cocks	9	1 7	5 10
Class 70.—Game (Duckwing).—Hens	7	1 1	4 0
Class 74.—Game (White and Pile) Cocks		1 4	5 0
Class 31.—Malay.—Hens over one year	7	1 1	3 10*

I may mention that there are one or two other classes that only equal this Malay class—for instance, Class 19, White Cochin hens. I have purposely omitted the Polish. Alas! like the Malay, they are no longer fashionable, and I have preferred taking the fashionable varieties.

I will agree that the breed has deteriorated. Is it wonderful when of late so little encouragement has been offered to it?—Y. B. A. Z.

MALAYS—REVISION OF CLASSES.

I was much pleased with the remarks made by Mr. Wright in your last week's number about the Birmingham Show of 1870. Touching Malays, true it is that a few amateurs have again this year subscribed each a guinea rather than have the class expunged from the prize list; but surely these amateurs must feel disappointed at the manner in which the prizes have been distributed in the four classes—viz., £3 the first prize and 10s. the second prize. Without further comment, although there is no accounting for taste, as an exhibitor I infinitely prefer the first prize. Judging from what I have seen and heard, I think that Malays this year will be better represented than ever, and that, owing to recent importations, Mr. Wright will have no reason to think that the breed is deteriorating. Several amateurs have lately started Malays, and I trust that they will enter them for competition at Birmingham, and let the committees of other shows see that henceforth they will be deserving of a class to themselves, and not be obliged to take refuge in the "Variety class" to be beaten, as has often been the case, by Silkies.

It would indeed be a great boon if many committees would revise their poultry prize lists, and not issue the same, as is usually the case, year after year. Why should there not be a class at every principal show for Black Hamburgs, one for Polish of any variety, and one for French fowls of any variety? At the last three shows that I have attended Black Hamburgs and Silver Polish have been first and second in the "Variety class," and many really good pens of French fowls, Malays, Gold-faced Bantams, &c., have been obliged to be content with high commendations. I am satisfied that if these three classes I have mentioned were to be found in the prize lists for 1871 they would not only be well filled, and the show rendered far more attractive, but greater encouragement would be given to the breeders of these excellent varieties.—A. G. BROOKE, Ruyton XI.-Towns, Salop.

NEW POULTRY MARKET.—It is satisfactory to learn that a Poultry Market is in contemplation, the proposed site being a piece of vacant ground adjoining the Metropolitan Meat Market. This would be a valuable addition to our already existing organisation for the supply of animal food. Next, we should like to see good and cheap vegetable markets, in which the poorer districts of London are sadly deficient. Perhaps the formation of one for poultry will cause more attention to be

paid to their fattening, from neglect of which we lose an immense amount of good food; and, as a commercial question, it would amply repay any country gentleman to try the experiment, as recently detailed in this Journal. Some years ago a Mr. Brooke attended before the Food Committee of the Society of Arts, and gave some very valuable information on the subject, which he offered to make known to the country at large, by going down to various towns on their market days, and instructing the small farmers and cottagers. But no action was taken upon it, as ought to have been the case, and so a valuable opportunity was allowed to slip away.—(Food Journal.)

[It is stated by the City authorities that the piece of ground referred to above affords double the area of the spacious Meat Market, and it is even more conveniently situated for those who are likely to be purchasers of poultry, being in the immediate neighbourhood of the Farringdon Street Station of the Metropolitan Railway.—Eds.]

RULE AGAINST TRIMMING.

CAN you, or any of your correspondents, inform me how it is that the Committee of the Birmingham Poultry Show have not a rule against trimming? I was quite surprised and disappointed, when I looked over the rules for this year, to find that they should have omitted such an important one, more especially so, as the Birmingham Show is considered the leading one of the day, and one which should set an example to the smaller exhibitions. Honest exhibitors do not like to trim their birds, neither do they like to be beaten with birds with pickled feathers. I sincerely hope that the Manchester and other leading shows will adopt a rule against such fraudulent practices, or else honest exhibitors will give up exhibiting.—A DISGUSTED EXHIBITOR.

SELLING EGGS BY WEIGHT.

WHEN eggs were worth from 6 to 12 cents per dozen, it was a matter of no great importance whether they were large or small, but now as they range from 20 to 40 cents per dozen, there is an item worth looking after in selection. There is nearly a difference of half in the amount of meat to be found in different lots of eggs on the market, and justice can never be done to the purchaser until they are sold by weight. Eggs weigh usually 1 1/2 lb. per dozen, and at 40 cents per dozen are expensive meat. When sold for breeding purposes, the present custom of counting may be the best. There would be an advantage to the producer resulting from a change as above suggested as well as to the buyer, for then every keeper of poultry would seek such breeds as would produce the greatest number of pounds in eggs, while now a hen which is prolific is profitable, let her eggs be as small as those of the Partridge; the object being to get number, not size or quality.—(Ohio Farmer.)

PRIZES FOR ANTWERP PIGEONS.

I HAVE read in your pages various letters advising persons about to purchase birds for forming a flock to have the Antwerp on account of its usefulness, quick breeding, and numerous other good properties. I quite agree with the writers, having kept birds of that breed for some time; still there is one great drawback to persons who keep them as a hobby, and like to show them now and then in order to know the merits of their birds—it is that at few shows are prizes given for this class of Pigeons. Now, I think this is a mistake, and I imagine if the committees could only read the letters to which I have referred, they would soon offer prizes, if not cups, for this class.—H. P. RYLAND.

ECCLESFIELD (SHEFFIELD) POULTRY AND PIGEON SHOW.

THIS Show was held on the 29th ult., and was one of the sections of the Agricultural Exhibition, and although there was but one prize offered in each class, yet the muster in point of both quantity and quality was of a respectable character.

The adult fowls were generally good, though most were in deep moult. The *Cochins*, *Spanish*, and *Polands* were of high quality, and shown in the very best of bloom and condition. The first-prize *Dorking* chickens were dark Greys, of enormous frame and good shape, and there were also several grand cockerels, with bad pullets. The Spanish chickens were also of nice quality, but the

* In this case amateurs assisted the Committee to offer the prizes.

Game only moderate as a class, though several single birds were very fine. The *Hamburgh* chickens in the winning pens were all correct specimens, and the winners in *Game Bantams* also good birds. The single *Game cockerel* was a capital bird in form and style, but a little flecked in feather. The *Geese* were large, but did not match in colour. There was but one class for *Ducks*, and *Aylesburys* won the prizes. There were large and excellent pens of birds, and many more prizes might easily have been distributed in the class. In *Pigeons* there were some good birds, notably the *Carriers*, which were Black. The *Almond Tumblers* were good and the *Blue Pointers* in the first-prize pen were of great length of limb and feather, closely pressed by a pair of capital *Red-pied*. In the "Variety class," *Black Swallows* were first, and *English Owls* and *Ice Pigeons* highly commended.

DORKINGS.—1, W. HARVEY, Sheffield. c, T. W. Overman, Sheffield Lane, Paddock. *Chickens*.—1, W. HARVEY, he, F. Crawshaw, Lonsley. c, F. Crawshaw; J. Swift, Deardlands. SPANISH.—1, Burch & Boulter, Sheffield. he, E. Brown, St. Philip's Road. *Chickens*.—1, E. Brown, he, Burch & Boulter. COCHIN-CHINA.—1, W. HARVEY, c, J. Boler, Hilltop. *Chickens*.—1, Burch and Boulter. he, J. Tomlinson, Sheffield. GAME.—1, F. Moody, Treoton. c, J. Denton. *Cockerel*.—1, F. Moody. *Chickens*.—1, W. Holden, he, W. Holden; M. E. Chambers, Chapeltown. *HAMBURGHS*.—*Golden-spangled*.—1, W. HARVEY, he, Burch & Boulter. *Chickens*.—1, Burch & Boulter. *Silver-spangled*.—1, W. HARVEY, he, F. Turner, Sheffield. *Chickens*.—1, W. HARVEY, he, F. Turner. *Golden-pencilled*.—1, W. HARVEY, he, Burch & Boulter. *Chickens*.—1, W. HARVEY, he, Burch & Boulter. *Silver-pencilled*.—1, W. HARVEY, he, W. Stead, Owlerton. *Chickens*.—1, W. HARVEY, he, W. Stead. BANTAMS.—*Game*.—1, J. Uylett, Pitonoor. he, J. Boler. E. Moody; W. Topham, Sheffield. *Any Variety*.—1, J. Tomlinson. c, W. Topham. *ANY VARIETY*.—1, W. HARVEY, GEESSE.—1, G. JACKSON, Munsborough. he, W. Shaw, Drakes. J. S. Shillite, Sheffield. he, J. K. Straw, Shiregreen (Ronen); E. Temple (Aylesbury); F. Crawshaw. TURKEYS.—1, Mrs. Booth, Brightholme. he, Mrs. Booth; G. JACKSON. c, G. JACKSON.

PIGEONS.

CARRIERS.—1, W. HARVEY, he, E. Brown, Sheffield. **TUMBLERS**.—1, W. HARVEY, he, E. Brown; H. Brown, Walkley. c, J. B. Mabson, Ecclesfield; J. Rider, Middleton. **FANTAILS**.—1, W. HARVEY, he, E. Brown; H. Brown, he, R. Cauwood, Ecclesfield. **JACOBIANS**.—1, W. HARVEY, CROPPERS or PORTERS.—1, W. HARVEY, he, H. Brown. **ANY OTHER VARIETY**.—1, W. HARVEY, he, G. Milner, Grimsthorpe; E. Temple (White Trumpeters); W. HARVEY.

The Judge was Mr. E. Hatton, Padsey, Leeds.

LITTLEBOROUGH POULTRY SHOW.

The following awards were made at this Show, held on Sept. 24th:—

GAME.—1 and 2 C. W. Brierley, Middleton. *Cock*.—1, E. Aykroyd. 2 and he, C. W. Brierley. *Hen*.—1 and 2 C. W. Brierley. he, T. J. Sunderland, Halifax. **BRAHMS**.—1, R. Hutchinson, Littleborough. 2, W. Trevor, Rochdale. he, J. Yates, King's Heath, Birmingham; J. T. Travis, Rochdale. **COCHINS**.—1 and 2, J. Greenwood, he, C. Whitehead. **BANTAMS**.—*Game*.—1 and 2, J. W. Morris, he, F. Steel, Halifax. *Any other variety*.—1, J. W. Morris. 2, J. H. Pickles, Birkdale, Southport. he, S. & R. Ashton, Mottram. T. Dixon. **DORKINGS**.—1, W. H. King, Rochdale. 2, H. Pickles, jun. he, J. Stott, Healey. **SPANISH**.—1 and 2, C. W. Brierley. **HAMBURGHS**.—*Golden-pencilled*.—1 and 2, T. Wrigley, jun., Middleton. he, H. Pickles, jun. *Golden-spangled*.—1 and 2, T. Wrigley, jun., Middleton. 2, H. Pickles, jun. *Silver-pencilled*.—1 and 2, H. Pickles, jun. *Silver-spangled*.—1 and 2, H. Pickles, jun. he, J. Cockerott, Kedgeley. *Black*.—1 and he, E. Brierley, Heewood. 2, C. W. Brierley. **ANY OTHER VARIETY**.—1, P. Unsworth. 2, H. Pickles, jun. c, W. Unsworth; H. Pickles, jun.; B. Hurst, Rochdale. **SELLING CLASS**.—1, W. Trevor. 2, C. W. Brierley, he, S. Crossley, Rochdale; G. Taylor, Huddersfield; H. Pickles, jun.; J. W. Brierley.

LOCAL CLASSES.

GEESSE.—1, J. Shepherd, Smallbridge. he, R. Hurst; F. Lord, Littleborough. **DUCKS**.—*Aylesbury*.—1, J. Buckley, Littleborough. 2, M. A. Crossley, Littleborough. *Rouen*.—1, E. Hurst. 2, R. Hutchinson. he, A. Consterdine; J. Walton; E. Lord. *Any other variety*.—A. Consterdine. 2, W. Stewart, Rochdale. **TURKEYS**.—1, G. Taylor, Littleborough.

PIGEONS.

PORTERS.—1, J. Hawley, Bingley. 2, H. Yardley, Birmingham. **CARRIERS**.—1, J. B. Pinder. 2, G. Taylor, he, H. Yardley, he, A. Consterdine. **TUMBLERS**.—*Almond*.—1, J. Fielding, jun., Rochdale. 2, H. Yardley. *Any variety*.—1 and 2, J. Fielding. he, F. Moore, Burnley. he, H. Yardley. **DRAGOONS**.—1, J. Wild. 2, J. Stanley, Blackburn. *he, H. Harreaves, Burnley. he, F. Graham; J. Watts. c, P. Unsworth. FANTAILS*.—1, J. F. Lovelandside, Newark-on-Trent. 2, H. Yardley. c, F. Graham; J. Hawley. **BABBS**.—1 and 2, J. Fielding, jun. he, A. Dove, York. **JACOBIANS**.—1, J. B. Pinder. 2, J. Hawley. **ANSWERS**.—1, E. Lee, Colne. 2, J. B. Pinder. he, S. T. Heap, Littleborough; J. Oldroyd, Wakefield; he, J. A. Colbison, Halifax; J. Oldroyd. **TERNTS**.—1, J. Fielding, jun. 2, J. B. Pinder. he, F. Moore; he, H. Yardley; A. Dove. **TRUMPETERS**.—1 and 2, J. Hawley. he, P. Unsworth. **OWLS**.—1 and 2, J. Fielding, jun. he, J. Stanley; A. Dove. **ANY OTHER VARIETY**.—1, J. Watts. 2, F. Graham.

JUNGES.—*Poultry*: Mr. R. Teebay, Preston. *Pigeons*: Mr. Kidpeth, Handforth.

OSWESTRY POULTRY SHOW.

This Meeting was held on September 29th, and being favoured by most lovely weather, there was an extraordinary attendance of visitors. The *Dark Brahmans* formed one of the most praiseworthy features of the whole Show; and in the face of a good competition the Hon. Miss Douglas Pennant took both prizes with birds shown not only in the most admirable condition, but such as have not as yet been brought before the public this season. They will in all probability add yet more triumphs to that lady's yard, as the prohibitory price of £20 each couple prevented their immediate appropriation. Many of the *Cochins* shown were capital chickens; Mr. Sidgwick took the chief prizes for these. *Hamburghs* were among the gems of the Show, and as they appear to be so little known in this district, the anxiety evinced by the public for a close inspection of these particular classes was extraordinary. The *French fowls* had separate classes, and both breeds were well and numerous shown. An amateur may attend many shows ere he meets with so excellent a class for *Any other variety* as there was at Oswestry: every pen obtained the favourable notice of the Judge. *Geese*, *Turkeys*, and *Ducks*, as is always the case at Oswestry, were remarkably good. Although here and there was to be seen an

unexceptionally good pen of *Game fowls*, there was not nearly such excellence in these breeds as at former shows.

GAME.—*Black or Brown-breasted Red*.—1, M. A. Forde, Maghull (Brown Reds). 2, J. Mason, St. John's, Worcester (Black-breasted). he, Rev. F. G. Bentley, Felton Grange (Black-breasted). *Duckwing Greys and Whites, or Piles*.—1, W. Dunning, Newport, Salop. 2, Barker & Charnock, Illingworth. he, J. Mason. c, Miss Saddler, Whitechurch. *Any colour*.—1, F. Parlett, Great Haddow (Coloured). 2, Rev. E. Bartrum, Great Berkhamstead (Coloured). he, E. Shaw, Oswestry (Coloured); T. Briden, Erby, Skipton (Coloured). c, E. Williams, Henlys, Berwick (Coloured). **COCHINS**.—*Brown or Partridge*.—1, C. Sidgwick, Ryddlesden Hall, Keighley. 2, no competition. *White or Buff*.—1, C. Sidgwick (Buff). 2, J. Dove, Moulton (Buff). he, A. Darby, Stanley Hall, Bridgnorth (Buff). c, T. H. Readman, Whitby (Buff); D. Thomas, Brecon (Buff). SPANISH.—1, J. Boulton, Bristol. 2, Mrs. Clews, Walsall. he, F. James, Peckham Rye; E. Brown, Sheffield. **BRAHMA POOTRAS**.—*Dark*.—1 and 2, Hon. Miss D. Pennant, Penrhyn Castle, Bangor. he, E. Leech, Rochdale. c, Rev. J. Evans, Crompton Rectory, Brecon. *Light*.—1, H. Dowsett, Pleshey, Essex. 2, T. Deane, Witley, London. **COCHIN-CHINA**.—*Brown or Partridge*.—1, W. Speakman, Dodington Park, Nantwich (Gold-pencilled). he, H. Pickles, jun., Erby. c, H. Pickles, jun.; T. H. Readman, Stoke-on-Trent (Gold-pencilled); J. Platt, Bolton (Silver-pencilled). *Silver or Gold-spangled*.—1, T. May. 2, H. Pickles, jun. he, Duke of Sutherland; Ashton & Booth, Broadbottom, Mottram (Silver-spangled). **CREVE-COEURS**.—1, J. J. Malden, Biggles, Walsall. c, E. Williams, W. W. Spring, Faversham; G. Bennett, Grove-Shipfall, Hotters. he, W. G. Unwin, Birmingham. E. Williams, ANY OTHER VARIETY.—1, Duke of Sutherland (Black Hamburghs); 2, H. Pickles, jun. (Silver Poland); he, C. Sidgwick (Black Hamburghs); Rev. A. G. Brooke, Ruyton XI-Town (Malays); W. Gamon, Chester (Polonds) (2). c, A. D. Payne, Luth Hill (Malays). **BANTAMS**.—*Game*.—1, F. Steel, Halifax. 2, J. Adams, jun., Walsall. c, J. Teggin Cross Foxes, Guboven (2). *Any other Variety*.—1, T. C. Harrison, Hull (Gold-laced Sebrights). 2, C. Drake, Stoke, Ipswich (Black Brahmans). he, Rev. A. Brooke (Maltese). c, E. Lodge, Erby, Cheshire (White); H. Yardley, Birmingham (Gold-laced Sebrights); T. C. Harrison (Silver-laced). **TURKEYS**.—*Polts*.—1, E. Leech. 2, E. Shaw. **GEESSE**.—*Goslings*.—1, E. Leech (Toulouse). 2, E. Leech. **DUCKS**.—*Aylesbury*.—1, E. Leech. 2, J. Dove. *Rouen*.—1, E. Leech. 2, F. Parlett. c, G. Cottle, Westleton. **SELLING CLASS** (Any breed).—1, E. Shaw (Cochins). 2, T. Foulkes, Oswestry (Black-breasted Game). he, H. Yardley; J. M. Foulkes, Llandyfaelog Rectory, Montgomery (Light Brahmans). c, E. Williams (Dorkings); Rev. J. J. Evans (Brahma Pootras). **GAME**.—*Black-headed*.—1, E. Pugh, Welshpool (Black-breasted Red). 2, S. White. **OSWESTRY** (Black-breasted Red). *Any Colour*.—*Bullets*.—1, S. White. 2, G. Cottle. he, Rev. P. G. Bentley, Felton Grange (2). c, E. Shaw. *Cock*.—1, S. White. 2, E. Pugh. **DORKING**.—*Chickens*.—1 and 2, E. Shaw.

The Judge was Mr. Edward Hewitt, of Sparkbrook, Birmingham.

DERBY POULTRY SHOW.

This Show was exceedingly well arranged, and the competition was exclusively confined to birds of the present year; notwithstanding, the prizes were, as a whole, very well contested. Some very good *Dorkings* were shown, but it should be borne in mind by competitors that however perfect in other respects birds may be, malformations of any kind are always inadmissible. A few of the pens of *Game* chickens were really good, but the majority of those shown were scarcely sufficiently matured for the show pen. The *Hamburghs* were the best ever yet seen at this Society's shows, and were excellent. The *Brahmas* were also worthy of very high approval, particularly the *Dark-feathered*. A large entry of cross-breeds, shown entirely on their merits as table fowls, caused considerable interest. The *Geese* were one of the most meritorious classes in the Show, and embraced Toulouse, White, and Saddle-backed. The special prizes for three pens of poultry of any variety, shown by one exhibitor, brought a competition of seven entries, and visitors seemed to regard this portion of the Derby Exhibition with unusual attention. *Pigeons* proved scarcely so good as we had hoped to find them. The promptitude, care, and attention of the Committee in the general management could not be surpassed, and the summer-like weather caused an immense influx of visitors.

DORKINGS.—*Coloured*.—1, A. F. Hort, Aldersley. 2, Countess of Chesterfield. he, G. J. Mitchell, Newark-on-Trent. c, Mrs. Arkwright, Sutton Scarsdale. *White*.—1, J. Faulkner, Bretby. 2, W. R. Dick, Ticknall. **GAME**.—*Dark-breasted*.—1, C. Minors, Sudbury. 2, G. J. Mitchell. c, J. Faulkner. *White or Pile*.—1 and he, W. Hollingworth, Dale Abbey. 2, C. Spencer, Thilston. **HAMBURGHS**.—*Gold-pencilled*.—1, H. Hineckley, Radbourne. 2, J. Bakewell. he, G. J. Mitchell. *Gold-spangled*.—1, J. Bakewell. 2, H. Hineckley. *Silver-pencilled*.—1 and 2, H. King, Melbourne. c, J. Bakewell. *Silver-spangled*.—1, C. Picketing, Kirk Landley. he, H. Hineckley. c, J. Bakewell; A. F. Hurt. **COCHIN-CHINA**.—1, J. E. Story. 2, G. A. Crewe, Etwell. **BRAHMS**.—*Light*.—1 and 2, A. O. Worthington, Burton-on-Trent. *Dark*.—1 and he, A. F. Hurt. 2, Rev. E. Alder. c, Rev. E. Alder; A. O. Worthington. **CROSS-BRED**.—1 and 2, A. O. Worthington. **DUCKS**.—*Rouen*.—1 and 2, A. O. Worthington. c, G. J. Mitchell. *Aylesbury*.—1, J. E. Story. 2, and c, G. A. Crewe. **GEESSE**.—1, F. Potter, Harbottle Moor. 2, J. Faulkner. c, J. Milnes, West Hamlyn; G. J. Mitchell; G. A. Crewe. **TURKEYS**.—1, G. J. Mitchell. 2, A. M. Mundy. **SPECIAL CLASS FOR BEST THREE PENS OF POULTRY**.—1, A. A. O. Worthington (Light Brahmans). 2, Mrs. Arkwright (Game). 3, G. A. Crewe (Partridge Cochins).

PIGEONS.

ROCK or DOVECOCK.—1, G. J. Mitchell. 2, J. Faulkner. **ANSWERS or BELGIANS**.—1 and 2, Mrs. Arkwright. c, J. Langley, Mickleover. **TUMBLERS**.—1, Mrs. Arkwright. 2, F. B. Wright. **FANTAILS**.—1, W. R. Dick. 2, J. Wood, Spendon. **ANY OTHER VARIETY**.—1, Capt. Fountain, Derby (Black Pointers). 2, W. R. Dick (Yellow Jacobins). c, Mrs. Arkwright (3) (Maapies).

The Judges were Mr. Edward Hewitt, of Birmingham, and Mr. Edward Lowe, of Comberford.

CANARY BUG.

HAVE any of your numerous readers in the Canary fancy ever tried the following simple remedy for the destruction of that dreadful pest, the Canary bug? Obtain pieces of elder wood, force out the pith, pierce several holes through the wood, so as to enable the little animals easily to find their way into the hollow, shake or blow through the perches into a basin of

hot water at cleansing time, and the result will be, if in accordance with my experience, very satisfactory.—J. M. S.

[That little gentleman, the Canary bug, is naturally of a retiring disposition, and will retreat into any crack, however small. If there be any crevice, even if almost imperceptible, it will soon be tenanted when the pests make their appearance. It is quite unnecessary to make traps for them. Any which might explore the hollow perch would form but a very small part of the regiments quartered in every available locality; and accommodation, however kindly intended, would not be by any means an effectual check upon them. I would feel disposed to cut off every retreat rather than to find furnished lodgings for them. Fresh air, plenty of ventilation, clean nest-boxes, and constant changes of nest, will do more to prevent their appearance than any other treatment.—W. A. B.]

THE CONTESTS OF QUEENS.

This is a subject which has been ably and fully discussed by Huber, but in making experiments to verify his statements the same results have not always followed. In introducing a fertile queen to a hive presided over by another fertile queen, he mentions that both the stranger and the reigning queens were immediately enclosed by the bees, and that the queens were virtually forced to decide by a single combat between themselves to which of them the throne should belong. Now, when introducing a queen to a hive in the circumstances mentioned, and without any strange bees accompanying them, I have never seen either the reigning queen encased, or the question of empire decided by a fight between the two sovereigns. The stranger queen has been invariably strangled by the bees of the hive to which she was intruded.

It is different when the subjects of a stranger queen are also introduced with her. Both queens are then encased, and a combat may, perhaps, take place between them, although I have never seen one. There are many apiarians who have never seen a deadly struggle between two queens. The late Dr. Dunbar was very anxious to witness a royal duel, but although he watched for one for years, he never had the good fortune to be a spectator of the conflict. Yet anyone who chooses may with very little trouble obtain a sight of queens in mortal embrace. Whilst admitting that the mother bee may and does occasionally put juvenile rivals to death when coming or about to emanate from their cradles, I imagine that fighting proper only takes place between virgins. As I have occasionally exhibited their encounters to friends, a description of the process followed may not be unacceptable to some readers of the Journal.

During the swarming season young queens are always plentiful, and two or three can often be found in a hive shortly after the issue of the second cast. Take two of these queens and with a hundred or two of bees accompanying each, put these miniature swarms in separate small boxes. Then towards dusk, when there is no danger of the bees taking wing, dislodge the two hives upon a large table near the centre, and about 1 foot apart from each other. The two clusters so dislodged break up, and their spreading circles are soon merged in each other. If the two queens are watched, it will be seen that they are comparatively placid so long as their presence is unknown to each other, but the moment the track or trail of one is perceived by her rival, the wings of the discoverer are raised, her pace is quickened as if in search of something, and it may be she will halt in her course and utter the piping sound heard previous to the migration of an after-cast. In a little while the queens meet, and if the opportunity is favourable a death thrust is given, generally by the stronger making a side embrace and curving her sting under the abdomen of the weaker. The disabled queen is then treated as a dying bee, dragged to the edge of the table, and thrown over.

About a month ago I had two young queens in my glass nicomb, the one dark and the other bright-coloured. The dark was slender-made, and the younger of the two. I happened to observe the first meeting of these princesses. There was first a sudden halt, then measured looks, then a rush by the dark one on to the top of the bright-coloured, the head of the upper being towards the extremity of the under. But the embrace lasted only a second or two, for the dark-coloured queen immediately quitted her hold and rushed in perturbation over the comb.

The fear awakened never left her, the slightest pressure of the crowd made her move precipitately. The light-coloured, on

the contrary, seemed quite at ease, and never once pursued her rival, but merely give a scowl at her whenever she approached too near. I watched the proceedings a whole day and saw the queens often meet, but the moment their antennæ touched, the dark-coloured fled apparently in great fear. The bees, however, contrary to Huber's experience, manifested no desire to make the two queens fight, they never once enclosed them or drove them together, neither did they display the least agitation. Ultimately, when darkness set in, the dark-coloured, as I expected, was slain by the light-coloured. "Coming events had cast their shadows before."—K. S.

MAIDSTONE AND MID-KENT NATURAL HISTORY SOCIETY.

At a recent meeting of this Society, the Rev. Walter Mitchell Vice-President of the Philosophical Society of Great Britain, gave an address upon the "Geometrical Structure of the Hive Bee's Cell." He said he had adopted the above title, as there were 250 different species of bees in this country, not one of which possessed the geometrical accomplishment and very peculiar construction adopted by the hive bee. This we called the domesticated bee, because it always followed in the steps of civilisation, or rather preceded them, for in North America the red Indian knew immediately the hive bee was established in the forest that it would be shortly followed by civilised man. The bee's cell was the most marvellous thing in creation, as far as our wisdom was concerned, in interpreting the works of the Creator, for those marvellous cells were made of a substance which it was extremely difficult for the bee to procure, and out of this substance it manufactured its houses, its streets, and its city. This city had three different classes of inhabitants—the queen bee, a few hundred males or drones, and several thousand neuters or working bees. He then pointed out that a bee on a given excursion fixed on a particular flower when it was collecting pollen dust, such as a wild rose or a lily, and visited those flowers only. The other bees collected honey for mixing with the pollen, and for the winter supply, which is put in the cells and sealed up. There was no creature whose habits the ancients were so fond of investigating as that of the bee—Virgil had written a great deal about bees—but none of them could tell from whence the bees obtained their wax. Some supposed that it was pollen, but on modern chemists burning it, they found that while pollen gave off an ash, wax gave none. This problem was, however, solved by John Hunter, the celebrated naturalist, who, on dissecting a bee, found that in the abdomen there were certain small bags containing a white substance, which, on burning it in a candle, proved to be wax, and it was, therefore, an animal secretion. The bee, therefore, had a chemical manufactory. He then described how the bees, during the summer months, gorged themselves with honey that this secretion might be produced.

In the construction of its cells from this substance the bee showed marvellous geometrical skill. Not only had the bee, led by its divine instinct, to gather honey and store it for the winter, when it knew it could get no food out of doors, but it exercised great economy in the use of that precious substance out of which it constructed its cells. The cells consisted of a great number of hexagons, or six-sided figures. The wasp, which had been a paper-maker since the creation of the world, made his paper out of wood, but he placed his comb, not vertically but horizontally. He made hexagonal cells, but he only made his houses on one side of the street—not back to back, as the bee did, and he simply covered in the bottom of his cell with a flat piece of paper. He displayed in this a certain amount of economy, but not the greatest amount of economy. The bees' cell, on the contrary, was terminated with lozenge-shaped bodies—like the diamond panes of a window—which, when they put their cells together, formed the bottom of a house, on the other side of the street.

The lecturer then described how the great French naturalist, Réaumur, by the aid of an eminent mathematician, discovered that the measurement of these cells by the differential calculus was exactly $109^{\circ} 28'$, and that they gave the greatest possible internal space with the greatest economy of material. The lecturer said, therefore, he concluded that we had not yet discovered the marvellous mechanism by which the bee produced this wonderful arrangement; and, with regard to the theory of natural selection, suggested by Mr. Darwin, he pointed out that the bee could not derive its instinct from its parents, for the working bees were neuters. The bees were wonderful archi-

WEEKLY CALENDAR.

Day of Month	Day of Week	OCTOBER 13—19, 1870.	Average Tempera- ture near London.			Rain in last 48 years.	Sun Rises.		Sun Sets.		Moon Rises.		Moon Sets.		Moon's Age.	Clock after Sun.	Day of Year.	
			Day.	Night.	Mean.		m.	h.	m.	h.	m.	h.	m.	h.				
13	Th	Day breaks 4h. 29m. A.M.	60.7	41.8	51.2	22	22	af 6	11	af 5	15	af 7	4	10	15	13	42	286
14	F		59.9	40.5	50.2	20	24	6	8	5	47	7	8	11	19	13	56	287
15	S		59.0	40.5	49.8	21	25	6	6	5	25	8	after	1	20	14	19	288
16	SUN	18 SUNDAY AFTER TRINITY.	59.0	40.1	49.5	18	27	6	4	5	13	9	5	1	21	14	22	289
17	M		58.8	40.7	49.8	19	28	6	2	5	11	10	5	1	22	14	35	290
18	Tu	ST. LUKE.	60.4	40.7	50.6	21	30	6	0	5	16	11	3	2	23	14	46	291
19	W	Twilight ends 6h. 52m. P.M.	59.4	41.7	50.5	22	31	6	58	4	morn.	9	3	24	14	57	292	

From observations taken near London during the last forty-three years, the average day temperature of the week is 59.6°, and its night temperature 40.9°. The greatest heat was 80°, on the 14th, 1861; and the lowest cold 21°, on the 15th, 1860. The greatest fall of rain was 1.04 inch.

GRAPES FOR EXHIBITION.



On reading the proceedings of the Fruit Committee at the Royal Horticultural Society's Meeting, September 21st, page 226, I came to the conclusion that a few notes on early and late Grapes would not be out of place, and I invite the attention of the committees of horticultural societies holding their exhibitions in autumn.

I would make a distinct class for such fine exhibition Grapes as Meredith's Alicante and Lady Downe's among the black varieties, as, unless this be done, the different varieties of Hamburgs cannot have justice. I would also have a distinct class for the Muscats and Trebbiano among white Grapes, so as to give the Royal Muscadine, the Sweetwaters, and the like a chance of winning a prize.

In support of this view I would ask, Is the flavour of the Alicante and Lady Downe's in August, September, or October to be compared to the taste of the Hamburgs? Also, Is the flavour of the Muscats and Trebbiano to be compared with that of the Royal Muscadine or Sweetwater? These questions should answer themselves.

I do not for a moment wish to disparage the fine qualities of the Alicante and Lady Downe's, leaving out the newer late sorts, for I am perfectly aware of their usefulness, but I say they are not to be compared with the Hamburg for flavour now; and were the judges to taste, undoubtedly there would be many exhibitors disappointed, for, instead, as is generally the case now, of the award being given to the fine large bunches, well coloured though they might be, it would go to the Hamburgs, they being ripe and fit for table (or they should be so when shown), which cannot be the case with the Alicante and Lady Downe's. To me it seems a sin that such fine bunches as I have seen shown in September should be cut, for, the taste being insipid, they are worthless.

I am fully aware that Grapes must be ripened and coloured by the end of September or beginning of October, or they stand but a small chance of colouring, unless it should prove such a favourable autumn as the present. But Grapes require to hang a certain time after they are coloured. Thus, the Hamburgs coloured by the end of July are not ready for cutting till the end of August, and those coloured a month later are not at their best yet. Above all, the Alicante should hang till February to bring out its flavour, and the same applies, or nearly so, to the Lady Downe's. Of course, I do not say they cannot be eaten till then, but I do say they are not at their best till the time I have mentioned.

Next, as to the white Grapes. The Muscats are undoubtedly the finest winter Grapes for those who have vineries and heat enough for them, but their flavour in August, September, and October is not equal to that of the Royal Muscadine, Buckland Sweetwater, and Foster's Seedling. The Muscats require a high heat to ripen them, and they must be ripened early, but they should not in any case be cut before Christmas.

I now give the names of a few good Grapes, black and white, for exhibiting. Of the black, there is none to excel the Black Hamburg as a show Grape, but a far superior Grape for flavour, though ripening at the same time, is Pope's Hamburg [Frankenthal]. This is a beautiful Grape, and no one should be without it where quality is considered. It has a very thin skin, a delicious flavour, and will hang till Christmas without deteriorating. Trentham Black is also good for exhibiting, but unless ripened, say, in July, it should not be cut till November; in fact, this is the best of the Hamburgs for keeping.

Of the whites, the best early is the Royal Muscadine. This is a very early Grape, and a good keeper. Ripened in a late house it will hang well till Christmas. Foster's White Seedling is also a keeping Grape of good flavour. All the above can be grown well with ordinary care and with but little fire heat.

The Alicante and Lady Downe's are both too well known to say more than that they are (leaving out the recent additions, such as Mrs. Pince), the best late Grapes, but they are not fit to be exhibited till the new year comes in, because, till then, we have plenty of far superior-flavoured Grapes, and no matter how fine a bunch of Grapes may look if they are acid or inferior to the palate. The Muscat of Alexandria, Trebbiano, and White Lady Downe's are, as I said before, good for late work, till then there is nothing to equal the Muscadines or Sweetwaters.

As it is now some time since I saw this subject discussed, I hope this short paper will be the means of eliciting a few remarks from some of your correspondents.—STEPHEN CASSELL, *Bent Hill Gardens, Prestwick.*

POTATOES.

THE Potato is, undoubtedly, one of the most important and valuable of all crops to those who are fortunate in having a piece of ground for the growth of vegetables; and I am one of those who do not believe there can be a home in the country without a nice little garden in front for flowers, and a plot of ground for the growth of vegetables. I believe if there were more gardens, one at least to every dwelling, that the beershops would have little charm for the hard working labourer, much less for the skilled and comparatively well-to-do artisan. There is not a creature on earth but has a liking for—a love of—plants, who does not delight in flowers, fruit, or vegetables; and there are none so ready to manage well the plot of ground they may have as those who by some means must, if they are to appear decent and respectable, keep from at every meal cutting at the bread loaf. It would be well if every house had its garden. It is a mine of wealth that none know the value of better than those who once possessed a garden, but who, unfortunately, have a house (it is no home) without one. Do not understand me as advocating a large garden to a cottage—one that has a large assemblage of fruit trees, of which the occupier may be heard to boast that this or that tree pays the rent. I believe large gardens to cottages are generally neglected. The occupier finds a large garden too large for what he

needs in the way of vegetables, and he plants it with standard Apple, Pear, and Plum trees in the hope of some day getting enough fruit to pay the rent. The trees grow, rendering the ground totally unfit for vegetables, and soon become an orchard of trees that need no looking after, and with them the greater part of the interest is lost. Some part of the ground is turned up, kept for growing Potatoes—they are indispensable—but they are often not worth taking up, and he grumbles at the work of his predecessor's hands. Fruit for small gardens is all very well, but it fills no gap like Potatoes and vegetables generally, nor is it nearly so needful for health.

In small gardens, however, there is no reason why fruit as well as vegetables should not be cultivated well and in quantity sufficient for the wants of a cottager's household; but it must not be sought by planting trees that, when full-grown, will render useless as much ground as would be required for the growth of enough of both to meet all the requirements of the family. Should the cottager, fortunate in having a plot of ground, rest content with only vegetables? By no means. On the contrary, let him have his Gooseberry and Currant bushes, and his bush or pyramid Apple and Pear trees, with Plums, all of which bear excellently in that form, and being always of reasonable proportions, do not render the ground unfit for anything except grass and weeds, as may be seen in many places besides Kent. The value of such trees is not known half so well as it deserves to be; indeed, I am convinced that a future generation will not retain, much less plant, a plot of ground with standard Apple, Pear, and Plum trees; for anyone who has planted both cannot but be surprised by the greater benefits offered by bushes and pyramids than by standards. Like standards, all bush and pyramid trees are not fruitful, but some kinds are extraordinarily prolific, affording more fruit, and of a finer quality, in three years than a standard in seven, and always as much in proportion to the ground occupied. I hope Mr. Rivers will favour us with an account of the most suitable kinds of Apples, Pears, and Plums—those affording the greatest quantity of the finest fruit, and with the greatest certainty. This would give an impetus to fruit culture in small gardens, the owner and family having within their reach fruit of the best out-door kinds, both as regards quantity and quality. I shall refer to the subject of fruit for small gardens at some future time, and I should not have alluded to it at present, but my object was to show the detrimental effects of large fruit trees on ground required in part for vegetable crops, and especially Potatoes.

It is a common error to suppose that good Potatoes cannot be grown in gardens. The ground is considered too rich, or it is said from some other cause they are indifferent in quality; but I have been a grower for upwards of twenty years, and am satisfied that they can be, and are, grown well in all gardens where the requisites are afforded. In many so-called gardens, which are in fact orchards, they do not thrive, nor can they be expected to do so, for the fruit trees shade the ground too much, and Potatoes, with vegetable crops of all kinds, endure least of all a rival. Open spaces are required for Potatoes; in no other can they be successfully cultivated.

An open situation, as I have stated, is necessary—one not shaded by trees, which are objectionable in several ways; their roots are quite as injurious as their heads, and they dry the ground in summer. There is nothing beyond this to hinder the cultivation of good sound Potatoes in gardens.

Next to the situation, the ground is the most important consideration. Almost every description of soil will grow this crop, but there can be no question that some soils are better suited to it than others; and yet this ought not to deter those with soil not so favourable from growing this most important tuber. Any soil may be made to meet all the requirements of the Potato, but first of all the ground must be drained; secondly, it must be brought into "good heart" and tith.

The ground should be well and deeply dug in November, and thrown up as roughly as possible. If at all heavy it is well to throw it in ridges, the narrower the better, so as to expose it to frost as much as possible. If it has not been trenched it would be well to do so, not bringing up too great a depth of the subsoil, if the latter is of a stiff inert description. Soils which have long been worked become when trenched almost as good as fresh land. If the ground is rich and full of vegetable matter or animal manures, no manure need be given. There is ground in gentlemen's gardens quite rich enough for Potatoes, but it is seldom so in small gardens; therefore, in digging give a good dressing of manure, preferring that which is fresh. It is wasteful to throw dung and litter in heaps to

ferment, driving off its most fertilising principles. Litter as it may be, dig it in during November, or, if the ground is to be trenched, place the manure between the bottom and top spit. It will rot in the ground, and it is an error to conclude that its manuring properties are washed out and carried off by rains. The soil has a remarkable power of seizing on ammonia and other important substances, which to a great extent are dissipated in a heap of heating and fermenting manure. I am convinced, from the great benefits of spreading fresh manure on the ground as mulching, that the system of manure heaps is an error. Decayed manure is very portable, and in every way more easily applied than fresh manure, but I am certain that one load of the latter is a greater stimulant to growth than two of that which has been thrown in a heap and left until reduced to a soapy mass, and it will cover twice as much ground. It is a fact also, that ground which has been turned up and exposed to the atmosphere increases in fertility, whilst ground left between crops to grow nothing but weeds, and with the surface close and firm, forms but a very indifferent medium for the succeeding crop. We often see ground left undug until it is wanted for cropping. Cottage gardeners and occupiers of small plots rarely dig until it is time to crop. It ought to be dug and manured as soon as each crop is off, so as to be ready whenever required. For Potatoes, as I said before, the ground should be dug and manured in November, and if possible in dry weather, and it will be more benefited than it would be by two or more diggings in spring. The frost will make the clods fall down, and greatly improve the soil's fertility.

In February, or if hard frost or wet weather occur, then in March, turn the ground over with a fork, and if it has been ridged up, level the ridges, giving the whole an even surface. All hard lumps of soil should at the same time be broken small. The soil being turned up early in spring it will soon be in a good condition for planting, and in no case ought this to be attempted when the soil when trodden on becomes a close, heavy mass which adheres to the feet.

Before planting we must consider the seed and the kinds. Of the seed, or sets, I would say, let them be of fair size, and as uniform as possible. If there are different sizes, plant each size by itself to secure that uniformity in the haulm which is pleasing to the eye. I admire nothing so much in Potato crops as regularity of growth. Some advise small sets, and, if the seed Potatoes are large, cut them to pieces; but I like a good set, and whole. I would not have sets weighing less than 1½ oz., nor need they exceed 3 oz. in weight. If the sets must be cut do not do it too hard. A cut set should be somewhat larger than a whole one. Select the seed from ground at a distance from that which you intend planting, and of a different kind, doing this every second, or at most every third year. See that the sets are sound, and if possible make sure that the first sprouts have not been previously rubbed off. Make sure of these; none are so good, nor will any afford such fine strong haulm, and fine, even-sized tubers. To prevent sprouting it will be necessary to keep the tubers cool in winter, but safe from frost. This is a very important matter, and one very much neglected.

To secure regularity in the crop, let the sets be placed thinly in boxes or hampers, or on a floor, at least a month before planting, and the place need not be a very warm one, for if the early kinds make sprouts from half to three-quarters of an inch long, and the second earliest sprout enough to exhibit their activity, it is sufficient. Long sprouts are so liable to be knocked off, that they are often a source of injury instead of being a benefit. I would plant none but those which show signs of growth.

With regard to varieties, I am very diffident about saying anything, as I consider there has been but little advance of late years, except in coarseness. Quality has not been sufficiently considered, therefore I may be excused if I still adhere to the old sorts. The new kinds have too much top, are too large, and have very large, deep-sunk eyes, causing much waste. Of very early kinds, there is none to beat the old Ashleaf Kidney. It is the best earliest sort for frames and the garden, but it is not a very heavy cropper, and must have prominence only for its earliness. Of this there are several so-called varieties, but all that I have grown have proved merely well-selected stocks.

Myatt's Prolific is a very fine prolific kind, much more so than the Ashleaf, and succeeding it by ten days. Except for very early crops this ought to be made the early kind, enough of the Ashleaf being planted to afford a ten-days supply. The Launceston is the best of all Potatoes, taking production and quality

into consideration. It succeeds Myatt's Prolific, and continues good longer than most varieties. It is a very weak grower in its early stages, and is tender on heavy, wet soils, which are not suitable to it; light and medium-textured soils are the best for it. Huntingdon is not unlike the Lapstone, but is a larger kind, many of the tubers weighing upwards of a pound under ordinary circumstances. It is not so tender as the Lapstone, and is better for heavy soils, otherwise it is inferior to the Lapstone. It is also later. Sultan is a pink Kidney; indeed, a pink Lapstone, having all the good qualities of the latter, and none of its defects, so far as I have experienced; it is not liable to disease, and is a first-rate keeper. The above are all Kidney sorts.

Of the Round kinds, Early Oxford is a second early, succeeding Myatt's Prolific. It is an excellent cropper, of good quality and size, but has the drawback of forming deep eyes; nevertheless, it is excellent from July to November, or later. Regent is, in my opinion, not superseded as a late Round sort, quality and productiveness being considerations. Fully two-thirds of the white Round sorts are like the Regent under different names.

The above are all the kinds I grow, or can see the advantage of growing. There are, no doubt, many others which will pass muster, yet I think the fewer the kinds grown the better, for there is the trouble and annoyance of having kinds which are often desirable only for affording a slight and not unfrequently supposed variation.

As respects planting, the ground being prepared as already described, the rest is easy. The line is stretched lengthwise or across the plot of ground, allowing from the outside of the plot half the distance the rows are to be apart. With a spade take out a straight trench 3 inches deep; in this place the sets, and cover with the soil from the next row. They need not be covered deeper than 3 inches, so that a wide trench is altogether unnecessary. If large enough to receive the sets at the proper depth, it is enough. For the Ashleaf I allow 2 feet between the rows, and place the sets 10 or 11 inches apart. To Myatt's Prolific I give 2 feet, placing the sets 1 foot apart in the row. Lapstone, Huntingdon, Sultan, and Early Oxford are allowed 2 feet 6 inches from row to row, and are planted 1 foot apart in the row. I like the rows to be a good distance apart, but to be so planted that the fork can hardly be got in, when taking up, without feeling the Potatoes. All the late sorts are allowed a yard between the rows, and the interval between the sets is 15 inches. Thus they form a mass of Potatoes. Some sorts I have grown would do well with an interval between each other in the rows equal to half the distance that the rows are apart, many being all top.

As to the time of planting, that will depend on the weather. Some have fixed times of planting, but there is no advantage in planting when the ground is wet and cold. The Ashleaf I like to have in by the third week in March, Myatt's in the fourth week, along with the second earlies, and the late sorts by the second week in April; but I would rather defer the planting a week or ten days than plant with the ground wet and cold. There will be exceptions to these times of planting as regards the early kinds in warm situations, but in open though not very much exposed situations I find the times stated sufficiently early for safety from frosts, whilst ensuring a good growth before hot dry weather sets in, and as a consequence the produce is good and well matured long before the autumn rains—a point I hold to be of importance.

The after-management consists in hoeing between the rows as soon as any weeds can be seen, and when the tops are 6 inches high I earth well up. I am aware some do not advise earthing-up, but I find that where it is not practised many green-ended tubers unfit for human food are produced; besides, they do not attain so large a size. The wider the rows are the better. A deep wide furrow between the rows is injurious by drying the ground, and preventing the rains from wetting the soil for a time after dry weather.

After the earthing-up no further care is required. The haulms will grow and keep under all weeds, but should any gain a hold, pull them up. As soon as the haulm turns yellow, the crop should be taken up and stored. It would be well if the tubers could be placed in a cool dry shed, but they should be kept dark. Light will cause them to become green, and they are then unwholesome. After they are dried no plan is so good as pitting. They keep most plump that way. For the pit a dry situation should be chosen.

Before closing, a word about cooking Potatoes. There is no mode equal to washing them clean, and then boiling them

until soft through; then strain off the water, and place them on the fire a minute or two until the water is dissipated, and finally peel either as you require them for eating or just previously. It is the most economical way of cooking, and the only one in which the full flavour is preserved. By peeling beforehand, and steaming or boiling afterwards, much of the best properties of the Potato will be carried off by the steam and water. The latter may be considered a cleaner process, but Potatoes cooked unpeeled will go nearly twice as far, and are fully twice as good.—G. ABBEY.

BEEF FOR ORNAMENTAL PURPOSES— STORING BEET.

ALLOW me space for a few notes upon the Red Beet's treatment here this year. The seed was sown on the 6th of April in a box placed in a pit heated by a flue. The seedlings were pricked out into other boxes when fit to handle and returned to the pit, where they were kept until well rooted. I then placed them in the open air in the shade, fearing that the sun would burn and spot them. On the 1st of June they were nice plants, and were planted out in the centre of two large beds to match, with two rows of Cloth of Gold Geranium all round, and bordered with two rows of *Lobelia speciosa*. The Beet is now a rich dark bronzed purple. Growing in rich ground it is not more than from 9 to 10 inches high, not one of the plants running to seed.

I think Dell's Beet should be a boon to the flower garden. Last year it stood the whole winter in the ground without any protection, still holding its leaves and looking very fine in the spring. What can be better in the way of foliage for the spring garden? Of course we cannot have *Iresine*, *Amaranthus*, *Coleus*, or *Perilla* in the spring garden.

I have this year a quantity of blood red *St. Osyth* Beet in the kitchen garden as good in colour as Dell's. There is more scarlet in its leaves than in Dell's, which causes it to glitter when the sun shines upon it, but it is not nearly so good in form as Dell's.

The best way I find for storing Beet for table use is in heaps in the open air covered with earth, which prevents it shrivelling or drying up, as it would do if it were kept in a dry shed or loft. I have had it here in good order for the table until the middle of July.—J. W., *Corwahn Gardens*.

ORCHARD-HOUSE EXPERIENCE.

I SUPPOSE there is hardly any subject which does not admit of argument both for and against. It must be so in a world where nothing (not even fruit and flowers) is quite perfect. Thus it is small matter of surprise that there should be much variance of opinion upon the subject of orchard-house culture. This, no doubt, in common with other questions, has its pros and its cons, and the wise man is he who, with impartial judgment, setting the one against the other, aims at striking a fair balance between the two; whereas the man of narrow mind, leaning to one side only, becomes, like the reader of a single newspaper, either a too zealous partisan or too bitter an opponent. Now, I will confess at the outset that, after several years' experience, I am an advocate for growing fruit under glass, but though an advocate, not one of such ultra views but that I see the expediency of aiming at the happy mean lying between the two extremes of opinion upon this matter.

Now, at the risk of provoking a smile from some of your readers, I will try to illustrate what I mean by striking a balance between the *pros* and the *cons* as regards orchard-house culture by referring them to Tupper's lines descriptive of a baby. A baby, like orchard-house culture, has its *pros* and its *cons*. It gives you smiles, but also wry faces; it crows, but it cries; it is a great comfort, but an unmitigated nuisance at times. Upon the whole it is a desideratum. But to my quotation—

"A babe in a house is a well-spring of pleasure,
A messenger of peace and love, a resting-place
For innocence on earth, &c."

An enthusiastic commencement, truly! So far the *pros*, if I may venture to apply so equivocal a word to *poetry*, seem to have it all their own way; but stay! mark what follows:

"Yet it is a talent of trust: a loan to be rendered back with interest:
A delight, but redolent of care; honey sweet, but lacking not the bitter."

All this is a true description, not only of a baby but of an orchard house. It is "a well-spring of pleasure," especially

when provided with a tank that would not run dry during such a season of drought as the one from which we are but now emerging. At all seasons—potting, blossoming, fruiting, stoning, growing, ripening, gathering—the orchard house is a well-spring of pleasure, a pleasant lounge, a pleasant divan, a pleasant scene of labour, not irksome, but like that of Eden—

"No more toil
Of their sweet gardening labour than sufficed
To recommend cool Zephyr, and made ease more easy."

A pleasant place of retreat (except when the sun is a little too warm) from the cares and business of life. It is, moreover, "a resting-place for innocence on earth." Yes, for innocence! Don't laugh! Orchard-house pleasures are innocent pleasures, and only to be truly enjoyed by innocent people. Surely if Izack Walton had a right to assume that all brothers of the rod were honest men, I may claim equal license to assert that my brother fruit-growers-under-class are innocent men. You cannot call anglers innocent. Gudgeons know them to be full of guile; but all of our craft, Messrs. Editors, are free from guile, and honest men to boot; and so, according to the inexorable logic of facts, as Count Bismarck would say, the orchard house is "a resting-place for innocence on earth." But now *audi alteram partem*. "Yet it is a talent of trust." Yes, here it is that so many make a mistake. Some wealthy proprietor of greenhouses and vineries must have an orchard house also. As he likes to have everything very nice he grudges no expense, thinking that, as a matter of course, abundance of fruit will result from a considerable outlay. The crystal palace is reared—a thing of beauty and a joy for ever; but he takes no pains about the selection of his trees, or potting them in a suitable soil; he never troubles himself about pruning, pinching, fumigating, lifting, watering, syringing, mulching. All that he leaves to his gardener, who has plenty else to do; and when he thinks, good easy man, full surely his Peaches are a-ripening, on inspection he finds his unhappy pyramids poisoned with aphides, or over-run with red spider, or starved for want of nutriment, or withering away from lack of moisture, or redundant with leaves from want of pinching and thinning, and no good joint coming to perfection. He either lays the blame upon his unlucky gardener, or else joins in the hue and cry that orchard houses are failures—all humbug—expensive toys—all very well for those who sell the trees, but of no profit to those that buy them, and so forth, forgetting the axiom that the orchard house "is a talent of trust"—a talent to be improved by himself, not delegated to another—"a delight, but redolent of care." Ay! mark well that formula, "a delight, but redolent of care." To be the former it must be the latter also, for without care—care incessant, personal, and loving, no orchard house, however costly, can possibly succeed. Yes, it must be redolent of care—not anxious, troublesome, carking care, but care that is pleasant, as all gardening care is, because full of hope, full of promise, sure to be rewarded; for has not the Giver of all good things made man's success to depend upon his endeavour, and as good as promised that "we shall reap if we faint not?" Want of personal care, and supervision, and interest lies at the root, depend on it, of all want of success in orchard-house culture.

I will only just add that, although the late season has been fruitful, yet in consequence of the long drought, out-of-door Peaches here fell from the trees before they were fully ripe, and that the fruit grown inside the orchard house has been far superior. We have had a plague of flies this autumn, and I intend bringing up my siege guns in the shape of Appleby's fumigators, of which I highly approve. I find it a good plan where Vines are trained beneath the rafters to have early Apricot trees in pots, because they are well advanced before the Vines put forth their leaves, and they can be easily moved if necessary to ripen their fruit in the open air; but then I have 108 feet of wall 13 feet high well covered with triple cordons, which supply me with abundance of Peaches and Nectarines.—A CONSTANT READER.

THE BERR KNOT APPLE.—This valuable kitchen Apple, I think, owes to us from the north. It has not the least resemblance to the English or any other Paradise stock, has large leaves, and large fruit of excellent quality good all the autumn. I find it in the "Catalogue" of the Horticultural Society, 1831; but I do not find it in the "Fruit Manual" by Dr. Hogg. In most cases it grows from truncheons planted in the ground, and it bears fruit the second year after being planted. It is, I believe, used as a stock in some places. Most of our

fruit-growing nurserymen know this Apple well.—CONSTANT READER.

COMPARATIVE PRODUCE OF POTATOES.

For the following report of results we are indebted to Admiral Hornby, Knowsley Cottage, Prescott, Lancashire. He thought that seed obtained from other localities and new varieties would be more productive than seed grown near Prescott and of older varieties. He also tells us that "of the sorts I send you, there is not one bad sort, but as to their keeping powers I have yet to see. The various sorts have been all treated exactly the same, and grown in light black soil."

Seed from near Prescott.	Weight of Old Seed.	Produce.	Seed from other places.	Weight of New Seed.	Produce.
	lbs.	lbs.		lbs.	lbs.
Early Coldstream	3½	43½	Gryffe Castle Seedling	3½	65
Transell's Seedling	"	63½	Yorkshire Hero	"	124½
Veitch's Kidney	"	112	Scotch Blue	"	48½
Lemon Kidney	"	50	Wormsley Kidney	"	75½
Mona's Pride	"	46½	Redbridge Ashleaf	"	71
Littlegreen	"	46½	King of Flukes	"	79
Daintree's Seedling	"	71	Early Emperor	"	140½
Early Oxford	"	86	Alexandra	"	73½
Ready Penny	"	62	Daintree's Kidney	"	199½
Regent (Paterson's)	"	77½	Gloucester Kidney	"	52½
Milky White	"	61½	Dave's Matchless	"	157½
Royal Ashleaf	"	57½	Wellington	"	88½
			Early Coldstream	"	71½
			Webb's Implr. Kidney	"	122½
			Harris's Nonpareil	"	77½
			Waterloo Kidney	7	138½
			Early Rose	"	267½
			Bresee's Prolific	3	197
			Bresee's King of the		
			Earlies	"	71
			The Queen's	"	115½

GIFTS OF BEDDING PLANTS.

At this season of the year in all large gardens many hundreds of fine bedding plants must be cleared off and committed to the limbo of the rubbish heap—a sad end to come to after affording so much delight. Would it not be better if they were given away to our poorer neighbours? This is done by public announcement in the case of the parks in the metropolis; can it not be imitated by private individuals in the suburbs of large towns?

What visitor to those lanes and courts will not bear willing testimony to the good effect, the quiet influence, of some well-kept window garden on the sunny side? Those painted boxes, those clean red pots, the plants without a dead leaf or withered branch, prove that there is no slatternly wife, no drunken husband within. The same care that attends to these objects will also see that there are no dirty windows, no filthy doorstep, no unwashed floor, and no uncombed children. From railway arches, too, are to be seen little oases in back yards, and wondrous parterres on housetops. Fevers are infectious; but the love of plants, the rivalry of bloom, and the accompanying habits of neatness and decency are infectious too, and we can powerfully second the efforts of those of our sisters and wives who visit the poor, by a distribution of plants in autumn and of a few pinches of seed in the spring.

Of course there will be a little trouble and some loss of time for the gardener, but a notice hung outside the gate to the effect that on a certain day plants will be given away on application will render the matter easy enough. I thus distributed last year from my small garden upwards of two hundred plants—*Calceolarias*, *Geraniums*, *Verbena*, *Heliotropes*, *Gazania*, &c., each of which would make several fine cuttings. Many large establishments must have cartloads of these, besides a surplus stock of *Crocuses*, *Snowdrops*, *Gladioli*, and other bulbs. If you think this communication likely to be of service in inducing anyone to try to do good at little expense, perhaps you will find a corner for it.—PENUMBRA.

ERADICATING WEEDS WITH CREEPING ROOTS.

In a recent number I saw a query from a correspondent respecting the possibility of banishing Couch and Bindweed. I have had, I regret to say, some experience of both, and consider it quite possible to banish them, the first step being to forbid the use of a spade, nothing but a fork to be used. One year my Asparagus bed was so full of Bindweed that it seemed as if the Asparagus had been grown merely as stakes for the

Bindweed, the crop being, as you may imagine, *nil*. I took it in hand myself, carefully followed every plant with a fork, and took up every root I could find; when this was done I gave the bed a good salting. I had a fine crop of Asparagus; of course a good many plants of the Bindweed came up during the summer, but these were forked up when they appeared, and now there are but few remaining. I think the salt killed much of the weed, as I found many blackened roots. I am now hard at work at the Strawberry bed, where the Bindweed is in quantity.

Another hint—when forking out the roots let them be at once put into a basket and no other weed put with them, and if the weather be dry let them be burned without delay. As every little piece grows and is thrown into a heap with other weeds, the supply will be increased.—AN OLD DUBLIN SUBSCRIBER.

PROTECTING THE BLOSSOMS OF WALL-FRUIT TREES.

I HAVE long entertained the opinion that a constant current of warm air passing over wall-fruit trees would be an effective preservative of their blossoms from frosts and cold winds. The only experiment I have been able to make testing my opinion was by placing a closed tin vessel at the foot of a wall, and filling it with boiling water. A thermometer hung against the wall, and 4 feet above the vessel, registered 30° of Fahrenheit's thermometer—or 2° of frost—before the boiling water was poured into the vessel. On this being done the thermometer began immediately to rise, reached to 40°, and never varied from that during the hour I continued the experiment. An easterly wind was blowing briskly, and I poured into the vessel fresh boiling water at intervals, so that its average heat was about 200°. Now this experiment and the geothermal experiments I saw in operation at Major Trevor Clarke's and elsewhere, justify the opinion I entertain. Unfortunately, at present, I have no means of practically testing its soundness, but I will state the mode in which I would test it, and, perhaps, some of your readers will give it a trial.

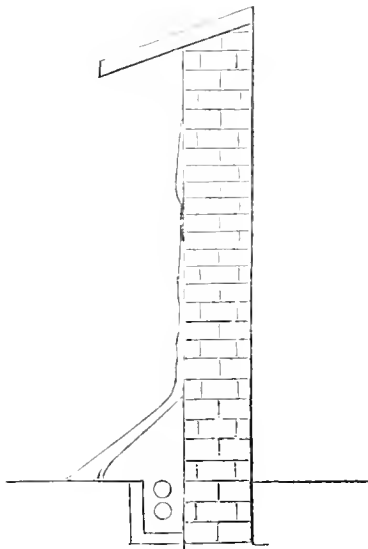

This represents a 3-inch flow and return pipe in a bricked gutter at the foot of the wall. The flow-pipe should have a valve to shut off its communication with the boiler, for the hot water would only be needed during the blossoming season. The return-pipe also should have a similar valve, but with a tap outside, so that the pipes might be empty during winter to avoid injury by freezing.—G.

ORCHARD HOUSE PRODUCE.—In an orchard house on a south wall we have a small Pear tree, Benrè Diel, on which grew three Pears. I weighed them when taken off, and I give the weights respectively:—One exactly 1 lb., one 14½ ozs., one 13 ozs. All were handsome. The house was put up last spring, and the tree was planted during March. We have had five Peaches,

Plums, Pears, and Nectarines in abundance, without overcropping, yet we have no fire heat of any kind.—A LADY SUBSCRIBER *Kirkcudbright, N.B.*

RIVERS'S SEEDLING PEACHES AND NECTARINES.

I HAVE grown and fruited in pots this summer some of Mr. Rivers's new seedling Peaches and Nectarines, and I have found the following varieties to be great acquisitions as regards earliness and flavour. They were grown principally on a glass-covered wall, but a few of the varieties were fruited on a south wall without protection of any kind.

Amongst Peaches the Early Beatrice was the earliest in ripening, being quite ripe by the middle of July; it was juicy in texture, and the flavour was good. Early Louise ripened about the end of July, but was not so juicy nor so good in flavour as Early Beatrice. Early Rivers ripened with me about the same time as the Early Louise and was very juicy, with a rich, racy flavour. Dagnar proved to be a large and finely-coloured Peach, and ripened in the second week in August. Dr. Hogg, another large and also a finely-flavoured Peach, ripened about the same time as the Dagnar. Early Silver, a very large and highly-flavoured Peach, ripened in the third week in August. Alexandra Noblesse has quite the pale colour of the old Noblesse, as well as its juicy and rich flavour; it ripens in the end of August. Lord Palmerston is a very large, pale Peach, and is at this date (September 15th), ripe, but the flavour is not first-rate. Princess of Wales is another very large Peach, pale in colour, with rosy cheeks next the sun, but it will be the end of September before it is ripe.

The order of ripening of Mr. Rivers's seedling Nectarines was as follows:—Lord Napier, a pale-coloured Nectarine of good flavour, and ripening in the beginning of August. Rivers's New White is better flavoured than the Old White, and ripens in the middle of August. Rivers's Orange, a seedling from the Pitmaston Orange, is an excellent high-flavoured variety, and ripens in the end of August. Stanwick Elruge has a smack of the Stanwick flavour in it, and ripens in the end of August. Victoria, the latest of Mr. Rivers's seedling Nectarines, is very rich and juicy when grown in pots, and ripens from the end of August till the middle of September.

Dr. Hogg Peach has ripened with me on a south wall, and was in season in the end of August; it is a variety of excellent flavour. The Pine-Apple Nectarine has likewise ripened on the same wall, and is an excellent new variety, the flesh yellow, like Hunt's Tawny, very rich in flavour, and the colour of the fruit nearly black next the sun.—WILLIAM TILLEY, *Walsbeck.*—(Florist and Pomologist)

ARKLETON.

THE railway traveller on reaching the city of "fair and merry" Carlisle has every opportunity and inducement held out to him by the convenient and numerous despatches of railway trains in all directions, by the excellent hotel accommodation, and by the kind and hospitable disposition of the people, to "break his journey" at the "border city." He will find here spots hallowed by associations with the past, which must ever remain dear to all lovers of history, archaeology, and romance. He will find a clean, well-built town, situated in one of the most pleasant and fertile-looking districts in the north. He can see the ruined castle whose rent and mouldering battlements still stand as silent sentinels, holding watch over the broad vale of the winding Eden, the silvery Solway, and the dear, old, brave Scottish border land. He may recall to memory the dark days and scenes of early Norman rule, when this time-battered fortress was founded by William Rufus, and how in succeeding ages it became the dwelling-place of David I. of Scotland, and the refuge and prison-house of the misguided, ill-fated Mary Stuart. He can wander in the choir and aisles of the grand, old, massive cathedral, and survey the decorated eastern window, pronounced by many to be superior even to the magnificent western window of York Minster. He can get a railway ticket, as I did, and leaving keep and castle, Kirk and cathedral behind him, travel for upwards of an hour through one of the finest-wooded, prettiest routes in Scotland. My hour's ride by rail landed me in the small, beautifully-situated, thriving, manufacturing town of Langholm.

But as I was in search of gardeners and their gardens rather than in quest of "wabsters and their clouts," I hastened

through the dirty, ill-paved street, and soon found myself in the policy grounds surrounding Langholm Lodge, one of the Duke of Buccleuch's shooting-boxes in Eskdale. The grounds, and especially the woods, reflect the highest credit on the good taste and judgment of the officer who manages them; but the gardens, both in arrangements and productions, are quite unworthy of their natural situation and their noble proprietor. In wide contrast to them were the well-planned, neatly-arranged gardens and vinerias at Arkleton, the residence of John Jardine, Esq., situated in one of the most picturesque parts of Ewisdale, about five miles from Langholm, and 450 feet above the level of the Solway. These gardens show at a glance the intelligence of the gardener and the liberality of the proprietor.

Arkleton grounds and gardens were planned by my old friend, the late Mr. Little, of the firm of Messrs. Little and Ballantyne, of Carlisle, and were executed by the present gardener in the years 1863 and 1864. Having heard that the gardener had acquired considerable fame as a grower of Grapes, Peaches, and Nectarines, I at once made my way to the vinerias. I found these to consist of two houses (Shaw's patent), each 30 feet long. I found the Vines were Black Hamburg, Millhill Hamburg, Golden Hamburg, Black and White Frontignan, Buckland Sweetwater, Muscat of Alexandria, Tynninghame Muscat, Archerfield Muscat, Mrs. Pince's Black Muscat, Black Alicante, Lady Downe's, and Syrian. I give the list in full, as possibly it may be of use to some amateur Grape-grower. I was credibly informed that all these Vines had been heavily cropped from the second year of planting, some five years ago, and that the average weight of the Black Hamburgs had been 2½ lbs., Lady Downe's 3½ lbs., and Muscat of Alexandria 3½ lbs. I was chiefly anxious to see the Syrian Vine, on which had been grown the marvellous bunch, 19 lbs. 5 ozs. in weight, which created such a sensation at the Show of the Royal Caledonian Horticultural Society, held in Edinburgh on the 7th of September last. This Vine has carried since it was planted in 1863 fourteen bunches, the heaviest weighing respectively 6½, 7, 8½, 16½, and 19 lbs. 5 ozs. The Vine is well trained, and is growing vigorously. I measured the wood of this year's growth, and found it was 3 inches in circumference. The old wood was 5 inches in circumference, and the leaves 19 inches by 15. It is highly to the credit of Mr. Dickson to be able to show such a plant, and to point to it as the bearer of the heaviest single bunch of Grapes ever produced in Great Britain, surpassing by 5 ozs. the famous bunch recorded by Speachley.

I made a short visit to the Peach and Nectarine house, and found it 180 feet long, with a drum trellis running along the front, and occupied with well-grown, healthy-looking, fruit-laden trees, among which were all the leading sorts in cultivation.

Altogether, my visit to Arkleton was a very pleasant one; nor less pleasant was my drive to Longtown through the wooded glen leading through the beautiful parish of Canonbie, and past its peaceful hamlets, its trim, well-furnished wayside cottage gardens, its elegant school-room, and its unobtrusive-looking church. I thoroughly endorse the opinion of Kohl, who declared that amid all his wanderings he never journeyed over a more lovely road than that which lies along the windings of the "wooded Esk" from Langholm to Longtown.—*BETA.*

CUTTING PEACH TREE LEAVES.

Will your correspondent, the Rev. W. F. Radclyffe, say upon what principle in physiology he bases his plan of cutting off the leaves of Peach trees to cause them to ripen their wood more perfectly? I have always been a great advocate for getting as much healthy foliage as I could on all kinds of plants, so as to produce the best type of healthy wood, and have hitherto considered the pulling-off the leaves before they had completed their functions to militate against the ripening of the wood, and consequently against the production of fine fruit. As with animals so with plants; if you wish to preserve them in health and to hear healthy produce you must endeavour to keep all their organs healthy, and not deprive them of what is necessary for the perfect development of their nature. If we wish to limit the size or surface of a tree we must withhold the food, this is the only check Nature will admit.—*J. SCOTT, Merriott.*

[In answer to Mr. John Scott, until fruit is off, and until September and October arrive, I should think it very far from in accordance with physiological principles to cut the leaves in half; but when, as here now, the triple buds are all formed and the fruit removed, I see no harm in cutting in half the

leaves. My trees, from disabbing so little, are now better-foliated than those of most people in the height of summer. I have a great many Peaches and Nectarines on west and east aspects; the former only receive a back and afternoon sun, and the latter only a morning sun and a little midday sun. It is, therefore, of importance to let in the sun and air to the wood after cropping is over, to harden and ripen it. I quite agree with Mr. Scott that good leaves are essential to fine flavour and the general welfare of the trees. I see many insects on my leaves, and by cutting them in half I am enabled to wash the insects off. If the fruit is gathered, people should follow up red spider, thrips, scale, and aphides till all are destroyed. I never saw a finer sight than the Peaches and Nectarines here this year.—*W. F. RADCLYFFE.*]

POMOLOGICAL GLEANINGS.

PEAR BRILLE ROUENNAISE.—Amongst the never-ending streams of new Pears, here is one which stands well forward. It ripens, it is true, at a season (October), when we have quite a glut of good fruits. In appearance it is very handsome, being of a rather long pyriform shape, tapering very much to the stalk, which is long and slender. Whilst hanging on the tree it is particularly graceful. The eye is closed, set in a very shallow depression; the segments of the calyx long, erect, and pointed. The skin is pale green, changing to pale yellow as it ripens, tinged a little on the exposed side with numerous minute crimson specks. The flesh is white, very buttery, and melting, very rich and sugary. Altogether first-class.

—**PEAR AVOCAT ALLARD.**—This is one of M. Grégoire's very numerous seedlings, and promises well. In quality it is quite first-rate. The fruit with us this season is rather small, but it looks as if it would grow to a goodly size. The flesh is pretty solid, a little soft; flavour very rich, with a strong muscat aroma. Season, October. We mark this as a promising variety.

—**PEAR HENRI NICAISE, HELIOTE DUNDAS.**—We grow the same Pear under both names, and must speak in high terms of its praises. In appearance it is fully more beautiful than the Forelle, or Tront Pear, which is so well known; it is of far higher quality, and the tree is more hardy, as it bears well as an open pyramid, which the Forelle does not. The fruits of Heliote Dundas are rather over medium size, obovate, beautifully flushed and streaked on three-fourths of the surface with brilliant crimson. The flesh is tolerably firm, yet melting and juicy, sweet, and rich. The tree bears profusely as an open pyramid on the Quince stock, and the fruit commands a high price in market on account of its handsome appearance.

—**APPLE SUMMER THORLE, OR WHOLE PIPPIN.**—We were lately extremely pleased to meet in Ireland with this old and particular favourite of ours, and to find it was so much cultivated and so generally esteemed. It is one of the first Apples we knew in our schoolboy days, and right well was it relished then; never, we believe, have we tasted Apples half so sweet, and even now there is a certain charm, a certain smack about this particular Apple which no other has. It is decidedly the best summer Apple of the north, both in Scotland and in Ireland, yet, singularly enough, it is seldom to be met with in the south, or in the neighbourhood of London. It is a very hardy variety, and a most certain and heavy cropper even as an open standard in the north of Scotland. The fruits are rather below the medium size, quite flat, like the Osain. Skin very clear, beautifully streaked with bright scarlet on the exposed side, and altogether very pretty. The flesh is white, quite crisp, juicy, and refreshingly sweet. The fruits are generally very uniform in character and quality. It is in use during August and September, and is best when gathered off the tree, or very shortly afterwards. It is an Apple much to be recommended, but greatly neglected.

ECKLAND VALE APPLE.

In page 268 information is wanted regarding the origin of this Apple. Ecklinville Seedling is the proper name of the Apple. It was raised from seed by the then gardener, probably more than half a century ago, at Ecklinville, a gentleman's seat about eighteen miles from Belfast and four miles from Portaferry. I saw the original tree growing there as a standard a good many years ago. At the back of the stables, on an eastern aspect, there was a fan-trained tree which bore noble

fruit. It was a sight. The steward and gardener who lived at Eckinville when I visited it was Mr. McLauschan, a very worthy man, who could exhibit other subjects worth seeing besides the above Apple. He used to show the Ecklioville Seedling at the horticultural exhibitions at Belfast as a kitchen Apple. It carried all before it there. As a sauce Apple there is none to equal it. What an Apple for a market gardener! The only wonder is that it has not been planted in this country by tens of thousands. Plants can be had in the Irish nurseries, at least in those around Belfast.—W. HUTCHINSON, Gardener, *Lwyndu Court, Abergavenny.*

PLANTS FLOWERING IN SEPTEMBER.

- Sept. 2. *Andryala lanata*
- Comanella coelestis*
- Anemone japonica*
vittata
- Chloris barbata*
ciliata
- Polygonum Sieboldi*
Brunoni
- Barnet
- Viburnum Tinus*
- Easter Beurre Pear
- Acronitum chinense*
- Napellus
- Cedronella cana*
- Celsia cretica*
- Daisies, double
- Aucuba-leaved*
- Xeranthemum*
- Potentilla rubrosa*
- Epilobium montanum*
- Lonicera Periclymenum*
- Serratula tinctoria*
angustifolia
- Mentha viridis*
piperita
- Rudbeckia lacinata*
- Neumann
- Eriogonum serotum*
- 3. *Oxalis Bowiana*
floribunda
versicolor
speciosa
- Coreopsis lanceolata*
- Lae
- Santolina incana*
- Tansy
- Fennisetum italicum*
- Schizostylis coccinea*
- Othonna pectinata*
- Calendula officinalis*
- Gaillardia picta*
- Linaria alpina*
Cynhalin
purpurea
- Caesula coccinea*
aurea
- Nepeta violacea*
- Abroux umbellata*
- Gilia triflor*
capitata
- Acaulis sp. rosus*
molis
luscianus
- Eritoca viscidula*
multiflora
- Achillea aurea*
egyptiaca
Clarencie
Millef luum
roscum
- Serratula plena*
tomentosa
- Solidago virgata*
canbrica
- 9. *Bartonia aurea*
- Potentilla alba*
insularis
- Aster tenellus*
- Phyteuma orbiculare*
- Gladiolus gandavensis*
hrenchleyensis
- Delphinium Ajacis*
- Myosotis palustris*
montana
- Plumbago capensis*
Larpeute
- Malope trifida*
grandiflora
- Penstemon glabrum*
ovatum
- Scouleri
- venosum
- Ammobium alatum*
- Eubothra asculis*
nana
fratitiosa
macrocarpa
taraxacifolia
- Gypsophila elegans*
- Cynerium argenteum*
- Helenium Douglasii*
- Pyrethrum roscum*
- Parthenium
- Calandrinia speciosa*
discolor
- Cineraria maritima*
- Nicotia hispanica*
- Colchicum autumnale*
- 12. *Armeria maritima*
vulgaris

- Sept. 12. *Artemisia vulgaris*
- Nolana paradoxa*
violacea
- Agapanthus umbellatus*
- Asarum coelestis*
- Callitriche platyglossa*
- Calliopsis nana*
Drummondii
- Ajaga reptans*
genesensis
variegata
- Tigridia Pavonia*
eschscholera
- Leptosiphon aureus*
densiflorus
luteus
- Salicornia herbaacea*
- Tritonia aurea*
- Fuchsia coccinea*
globosa
- Hibiscus africanus*
- Linaria bipartita*
striata
- Loasa kurandica*
- Soldado Virginiaea*
- Athanasia annua*
- Atriplex hortensis rubra*
- Aristolochia Clematitis*
brachneum vulgare
- Arcotis heviscapa*
- Arzemon grandiflora*
- Tradescantia curculio*
viridica
- Calceolaria pinnata*
dentata
- Senecio Jacobaea*
elegans
- Cuphea platycentra*
- Lobelia erinus*
amosus
- Malva Moreni*
- Stenactis speciosa*
- Sida pennata*
- Symphytum caucasicum*
coccineum
- Lophospermum scandens*
- Dracocephalum spectosum*
moldavicum
canariense
- Symphyantra pendula*
- Echeveria alanca*
- Echinops Ritro*
- Erica stricta*
ramentacea
vazans
- Vines major*
minor
- 16. *Saponaria ocymoides*
- Helicofrasms*
- Senecio adonidifolius*
- Silene Schaffi*
pendula
- Lathyrus grandiflorus*
latifolius
venosus
- Clarinas
- Hydrocharis morsus-ranae*
- Tratoma Uvaria*
grandiflora
- Verbascum Thapsus*
- Scrophularia nodosa* va-
riegata
- Anaxallis grandiflora*
Breweri
- Amsonia salicifolia*
- Orobas aureus*
- Nierembergia gracilis*
rivarlaris
- Lupines
- 20. *Narthecium ossifragum*
- Claytonia perfoliata*
- Mirsibilia Jalapa*
- Clinomania pulchella*
- Asclepias Douglasii*
tuberosa
- Sedum caruleum*
- Centauria candidissima*
gymnocarpa
- Chamaepuce Sababone*
- Aster Amellus*
luteus
Nova-Anglie
Novi-Belgia
cyanus
punicus
sericeus
- Tagetes pumila*
- Tropaeolum majus*
minus

- Sept. 20. *Polygonum orientale*
- Lathyrus mazellanicus*
- Mitraria coccinea*
- Monarda didyma*
purpurea
- Agrostis nebulosa*
- Morina persica*
- Primula acaulis*
- Reseda lutea*
- Zinnia elegans*
- Sedum album*
purpureum
monstrosum
- Telephium
- Sieboldi
- variegata
- spectabile
- 24. *Lilium speciosum album*
rubrum
- Harrisona
- Stachys germanica*
lanata
- Campanula grandis*
garganica
maralis
persicifolia
pulsilla
pyramidalis
- Amaranthus speciosus*
- Calystegia pubescens*
- Aubrieta deltoidea*
purpurea
variegata
- Campanula Speculum*
- Linum alpinum*
perenne
Lewisi
- Statice helidifolia*
lucana
Gmelini
latifolia
- Candytuft
- Aloesia cutirodora*
- Whittia grandiflora*
- Viola cornuta*
lutea
tricolor
- Balsam
- Kochia coparia*
- Calceolaria plantaginea*
- Tropaeolum peruvianum*
- Sauvitalia procumbens*
- Echremocarrus scaber*
- Portulaca splendens*
coccinea
- Phlox Drummondii*
- Ocala tropaeoloides*
- Verbena venosa*
pulchella
- Chelone barbata*
coccinea
obliqua
- Alyssum saxatile compactum*
- Centanthus macrocephalus*
- Cladanthus arabicus*
- Lavandula spica*
- Matris pycnostachya*
- Mimulus maculosus*
cardinalis
atrocaeruleus
moschatas
luteus
- Scabiosa lutea*
- Alonsoa compacta*
grandiflora

- Sept. 24. *Phloxis Russelliana*
- Melissa officinalis*
- Corydalis lutea*
semper-virens
- 26. *Euphorbia ephymoides*
- Veronica caudata*
dentata
incana
spicata
- Andersoni
- speciosa
- Eubothra Drummondii*
- Selloviana
- hiemalis
- Potamogeton natana*
- Datura Stramonium*
- Vitadenia trilobata*
- Adonis autumnalis*
nivalis
- Thymus lanuginosus*
- Androsa italica*
semper-virens
- Convolvulus caubricus*
mauritanicus
- Arabis lacina*
- Apocynum venosum*
- Acerolium roscum*
- Ageratum mexicanum*
- Silene maritima plena*
noctiflora
- Dianthus barbatus*
deltoideus
superbus
- 30. *Savilla bicolor*
fulgens
patens
splendens
- Genm coccineum*
rivale
- Helianthus annuus*
diffusus
multiflorus
stratiflorus
- Lotus corniculatus*
- Cyclamen europaeum*
hederifolium
- Gaillardia Richardi*
grandiflora
- Hydrangea*
- Iberis Tenoreana*
- Crocus nudiflorus*
apicius
- Epilobium angustifolium*
- Delphinium Belladonna*
- Dahlia imperialis*
- Lupinus polyphyllus*
- Dactylis glomerata* varic-
gata
- Eragium alpinum*
- Legenis falkens*
chalcidonica
- Haageana
- Viscaria
- Antholyza coccinea*
- Lithrum roseum*
- Salicaria
- Scutellaria alpina*
- Lamium maculatum*
- Eupatorium cannabinum*
- Hieracium aurantiacum*
- Clethra amifolia*
- Rudbeckia amplicianalis*
- Salpiglossis atropurpurea*
- Polemonium carolinum*

—M. H., Aeklam Hall, Middlesbrough-on-Tees.

A YOUNG GARDENER'S GROWL.

Would you be so kind as to solve the following problem—How are young gardeners to learn to know fruits, their qualities, &c., when never allowed to taste? My own experience is, that you may look but not touch, and even if seen to be looking very minutely you are suspected of eating. Now, when fruit trees are not labelled, as in far too many cases they are not, it is a matter of some difficulty to learn to recognise apart a dozen of each of the best hardy fruits. Yet that is a small number towards the many varieties that are in cultivation. I am ashamed to own it, but I could not pick out a dozen varieties of all the hardy fruits by taste and appearance to be in any way certain about them, and yet I have been eight years at the trade. Certainly I have been chiefly out of the great fruit-growing districts. I have been under different gardeners, but only one ever offered to give me the slightest chance of learning the qualities of fruits, though often asked in a quiet way. It is not pleasant to be obliged to go about like a thief, as indeed one is, to get a taste of fruit which you are expected to know full particulars about. It is my belief that a third of the gardeners do not know one-quarter of the different fruits in cultivation, and apart from a list would be puzzled to name a collection to stock a garden, so as to give a proper and successful supply of fruit. What I say of hardy fruits is still more applicable to in-door fruits—Grapes, &c., as it is not in many places that there is anything like a complete collection. Your eyes will tell you the difference between a Black Hamburgh and a Muscat of Alex-

andria, but as for more you must wait till you have Vines under your own care, and then you may have a little opportunity of comparison. You may get over being caught taking a Plum or an Apple, but to take and nip a berry out of a bunch of Grapes, oh, dear! that would be enough to send your box to the nearest station, or at least to insure a lecture a yard long, and to have the vinery door locked.

Of course, where fruit is very scarce, it must be husbanded, and cannot be allowed to go for young gardeners to taste and compare, whether they are ignorant or not; but then so very little is needed with the help of Dr. Hogg's "Fruit Manual," that I cannot but think the lamentable ignorance of which I complain might be in a great measure remedied.

Then, again, in regard to new vegetables, it is the same. Young men in the bothy must not expect to taste new Peas and Potatoes. The difference between good and bad is of no moment to them now; when they are in a place of their own is time enough for them to begin to know. For the first year or two let them accept seedsmen's and nurserymen's opinions, and then after making some mistake or mistakes which nearly cost them their places, they will learn.—A YOUNG GARDENER.

P.S.—I hope you will excuse my growl, but it eases one's mind.

[There is, no doubt, some truth in what you say, but we have found that it is the easiest matter in the world to find or make a grievance. Some young gardeners, like young men in other trades and professions, find that there is no royal road to knowledge of any kind. Where young men enter on gardening as regular apprentices or improvers, and directly or indirectly pay so much for instruction, it is only fair that that instruction should be given according to the capabilities of the place. Where a labourer picks up knowledge as he can, and where all the gardener can receive from him is merely a regular and appointed amount of labour, he can hardly be expected to get regular instruction on all points from the gardener. Partly from getting labour better done, and partly from a large-hearted generosity, gardeners have been the most liberal of men in imparting whatever knowledge they may have possessed. In fact, there is no trade or profession where the peculiar knowledge of the trade is so much and so frequently made a matter of public property as in gardening.

Young men in gardens, in general, form no exception. It is seldom that a man anxious to get on, active, attentive, persevering, and obliging, would be debarred from any knowledge he solicited in a proper way. It is by such means that some of our best gardeners have risen to the top of the tree. Their good, upright, obliging conduct has made many friends for them wherever they went. But those who have had most to do with young gardeners will be the first to own that all of them do not possess these attractive qualities. Many professedly going to a garden for improvement, seem to care about little except to get over as easily as possible the day's labour; and if they feel so little interest themselves, it is not likely that the head gardener will repeatedly trouble himself to give the explanations and information that are received so carelessly. In general, then, where there is a great amount of ignorance, after a long period of probation, we would be more inclined to refer that ignorance to the carelessness of the man than to the proud indifference of the master. Of course, to every rule there are exceptions. Gardeners, and the best of them, are but men. On the whole, we think that many young gardeners hold unsound notions of what head gardeners are bound to do for them; and dwelling on this they remain ignorant of what they might know but for their proud indifference and carelessness.

Again, it would be well if young gardeners, and many of the public, too, would recollect that a head gardener is merely a servant, having charge of a certain amount of property, for which he is responsible to his employer. In most places there is a little latitude as to giving and receiving, but it is dangerous to act upon it without a clear understanding. Mere use is not sufficient if a man wishes to be above suspicion and all underhand gossipings. Many a gardener, to our knowledge, has gained the character of being hard, near, and close-fisted, when he was merely and simply honest and faithful to his trust. Gardeners are not unfrequently annoyed by employers being suspicious now as to what becomes of the effects of the garden. They thought they should have had a greater abundance of this, and a better supply of that. We hardly know how it would be if assistants were allowed to pick and taste at their will. Such suspicious proprietors might then think it best to get rid of their suspicions, and their garden too.

Under such circumstances gardeners have often a sad time. They know that things lessen and lessen, and cannot find out how. We fear it is not always the assistants that are to blame. Many think it no harm to pick when they have a chance, though having no right whatever. Visitors should use no more freedom in a garden than they would dare to do in a grocer's or haberdasher's shop. In many places a bad practice prevails of allowing visitors at the mansion to make themselves free of the garden. Under such circumstances the gardener is often at a loss how to get a good dessert, and if there are many assistants, a great temptation is presented to them to do as their betters do. We have seen a gentleman finger-and-thumb a score of Noblesse Peaches before he found one to his mind, and every one of those Peaches would retain the mark. In a few instances the employers may be anything but straightforward. We knew a gardener who was thus treated. The lady found fault day after day, that the fine wall fruit were disappearing. He was obliged to own it, but could not tell how. He had the borders fresh raked every morning, so that a single footstep should be seen; but still every day, without a single mark, few or more fruit were taken, and all his watching seemed useless. Having got half through his dinner one day he thought he would go out and look at the wall, and there was the proprietor using a long hooked stick to take the fruit off the wall, and trundling them across the border without leaving a mark. We have often fancied the looks exchanged. We have sometimes felt what a wrong it was that the character and the position of a gardener should be so much in the power of such an employer. What would some employers with just a spark of suspicion about them think, when they found out that the garden assistants were not merely workmen but tasters and consumers of their best fruit and vegetables?

The abuse in such matters has often led to the disuse of good customs, and thus the innocent have suffered for the guilty. Not so long ago a gardener was keeping carefully a fine lot of Cauliflower for a ten-days company, and had the half of them taken in one night. Another time the first gathering of a new Pea that the employer had heard about disappeared in the same way, and later still some kinds of new Potatoes, planted carefully for trial, had been all grubbed over with the fingers and a pointed stick, so that the objects in planting, in comparing samples and qualities, were completely frustrated. It would have been easy to have known where they went to. Even our correspondent would be inclined to own that this was both-tasting with a vengeance. Can anything of this kind be the reason why in many places now the young gardener assistants must live out in lodgings?

The picking and tasting and pocketing of fruit, is often more trying than even the loss of a few of the best vegetables. Often the best fruit intended to crown a dish are missing, and Mr. Nobody does all the mischief. A most liberal-hearted proprietor, on seeing a number of men gathering a nice quantity of small Strawberries from a quarter after all the best had been obtained for table and preserving, said he liked the principle, but if after such indulgence a man should be found helping himself except where allowed, he must be discharged there and at once. We know, too, many cases where kind indulgences have been altogether withdrawn because they were made the cloak to carry matters to an excess. Young gardeners and garden labourers may retort that old head gardeners might be equally guilty when young. That may be true, and yet not mend the matter. We should say, however, that gardens since then are doubled, or rather trebled in number, and proprietors now look more carefully for returns for the money expended.

We have been thus diffuse in going beyond our correspondent's complaints, because we wish to note the importance of these matters to all concerned.

1st, That the proprietors of gardens should not to any great extent exercise their undoubted right in picking and gathering fruit and other produce without the knowledge of the gardener.

2nd, That the same rule should apply to their visitors, and on similar conditions. This is especially necessary where a number of assistants are employed, as the frequent infraction of it would present to them great temptations, and we consider it wrong unnecessarily to put temptations in the way of any one. What would be thought of ladies and gentlemen going to a dairy, helping themselves to cream and butter, and pocketing eggs, and taking notice of nobody? Would it work well if pantry and larder were invaded and the contents freely abstracted, and yet a housekeeper, and cook, and butler be considered responsible? The same principle applies in a garden, when visitors take just what they like and disfigure what they

leave. You cannot make a gardener feel his responsibility whilst his employer and his visitors are constantly undermining that responsibility. The practice opens a wide doorway for all other petty pecculation, and seeing such a lady or gentleman at such things must be to him a sufficient reply if the gardener suspects a workman. Remember, we question not the right of proprietors to do as they like. Some time ago one of our amusing lady friends described the pleasure she had in culling and gathering garden produce, and how cross the old gardener looked. We would not deprive such of the pleasure, but they might have that and wreathe the old man's face with smiles by just telling him what they have done. If not, and if there are many assistants, they will suffer.

3rdly, So far as assistants are concerned, there is only one safe rule, that they pick and pull nothing from an Apple to a Grape without the cognisance and permission of the head gardener. We recollect when young thinking it very hard that a man who had lived a number of years in a place was told he could never more be trusted, because he was seen to gather and eat a few very early forced Strawberries. It was the principle that was involved; as the place was large, if everyone having access to the house had done the same there would have been small returns to the de-sert-table.

How, then, are young gardeners to know anything of the taste and qualities of fruit, and vegetables, and roots? Not as in the cases just referred to, by bringing their tastes in antagonism with the tastes and the rights of the proprietor; not by acting as if they thought that their main duty was to get as much as they could, instead of remembering that proprietors chiefly look on them and regard them from the utility point of view; not by acting as if their labour was a mere routine, and looking more at the clock than considering the causes and effects coming constantly before them; but by exhibiting industry, attention, and integrity, combined with an obliging deportment; and then, just as love begets love, nearly every gardener would be as anxious that his assistants should taste anything nice and new as he would be to taste it himself; and thus directed, a very small quantity will go a great way.

We may add here, that even where vegetables can be spared it is well that these should not be taken, but in small places be given by the gardener, and in larger places be collected for that purpose by the man who serves the kitchen, and who will then be responsible that no scarcity shall be felt there. From want of such simple rules, what was once a privilege to be cared for has been lost altogether.

On other parts of our correspondent's letter we do not enter, farther than to agree with him that the most of gardeners do not know the names, and far less the qualities of the fourth part of the fruit cultivated. Just as in the case of the Rose, it will often be better to cultivate a few of the best sorts than to have a number of them. It is hardly reasonable to expect, amid the many things required to be thought about every day by general gardeners, that they can know fruit like the late Robert Thompson or our present Dr. Hogg. It would perhaps be well if more made fruit one of their especial studies; and hence it is desirable that young men whose bent is chiefly in this direction should not waste their time in ordinary gentlemen's gardens, but should rather seek employment in nurseries and gardens where fruit is the principal thing. We have no fault with any man for making fruit the first object, but taking gentlemen's gardens as a whole, gardeners must think of vegetables first, fruit second, and flowers third. Everyone should gratify his taste, and there is no want of the means of doing so. That will be better than grumbling that he cannot get what he wants in a certain position.—F.]

LARGE CROP OF LAPSTONE POTATOES.

As we hear from time to time much about Potatoes, I have forwarded for your inspection a sample of Haigh's or Lapstone Kidney grown in old garden soil, enriched with hotbed manure, one-half being leaves. The ground was dug in winter, and a sprinkling of salt applied on the surface at planting time. On the 5th of April we trenched in the sets, allowing 28 inches between the rows and 12 inches from plant to plant, placing them about 4 inches deep. When the shoots appear above the surface the plants are kept free from weeds by the hoe being freely used among them, and as soon as they are well above the ground quicklime is applied pretty freely among them, and carefully forked-in. When the tops are about 6 or

8 inches high the plants are earthed-up and left to take care of themselves. On the 20th of September we lifted the crop in prime condition, and the yield was at the rate of 15 tons per acre. A sample is forwarded. The whole was free from disease, and of first-rate quality.—M. H., *Acklam Hall, Middlesbrough-on-Tees.*

[The sample sent to us was very fine and clean-skinned. Three weighed 2 lbs. all but a quarter of an ounce, and all the others were similarly sized. When boiled they were very floury, and of excellent flavour.—Eds.]

ALTON TOWERS,

THE SEAT OF THE EARL OF SHREWSBURY AND TALBOT,
ALTON, STAFFORDSHIRE.

VERY beautiful, very interesting, and certainly very singular are the flower gardens and pleasure grounds of Alton Towers. Different in character from almost all other English gardens, they may be said to consist of a number of curious designs, the rich and elaborate details of which present so much of novelty, that as one passes from scene to scene the feeling of freshness and interest is fully sustained throughout. The rich masses of foliage, in all the various shades of colour, on the deciduous timber trees, mingle with that of the more sombre-leaved Pinuses, clothing the steep hillsides of this "happy valley;" the various curious structures dispersed about, some quaint and fanciful in design, and others even more attractive by their elegant proportions and the commanding positions which they occupy; the numerous groups of statuary, the vases, sheets of water, cascades, terraces, glass domes glittering in the sun, and the flashing waters of the fountains—all appeal to us, exciting our interest and commanding our admiration. Nor does this feeling pass away when, leaving this "land of brightness," one passes onwards, either along walks where constantly-occurring bold, stern, rugged masses of rock protrude from overhanging banks in all that grandeur and dignity which is their peculiar property, or under living arcades formed by the arched boughs of trees, or along sloping banks, on which grow vast numbers of Rhododendrons, interspersed with wild Ferns—all tending to impart a romantic air of semi-wildness, totally different from the trim neatness of ordinary shrubberies, but still so well managed as to be quite free from any appearance of slovenliness, and, in fact, just sufficiently dressed to render the whole agreeable, while the graceful freedom of the wild woodland is retained in its fullest integrity.

What appears to me to be most wanted here is a greater expanse of turf among the shrubs, the groups of which are now so near to each other that they appear crowded and confused in many parts; more turf would impart breadth and dignity, and would relieve the monotony of these "wooded banks;" for even the most elegant exotic shrubs, when seen crowded together in such profusion, have a tame and unsatisfactory appearance.

Mr. Rabone, the gardener, whose kindness and courtesy I beg to acknowledge, is gradually effecting many improvements, such as opening up vistas through the woods, and cutting away many overgrown shrubs which obscure or confine the views; and from the admirable manner in which this is being done much valuable and important scenery has already been gained, and it is a matter for congratulation that this charming place is under the care of such an able manager.

The delightful walk from the Alton station, by which I went to the gardens, prepares one for the peculiar treat which is in store. Passing through the ornamental lodge-gate near the station we proceed up an ascent, so steep that numerous flights of steps are introduced at short distances from each other. This picturesque walk winding upwards among fine old Fir trees, the sides of the banks being richly clothed with Ferns, passes over the crest of the hill near a colossal mass of rock, which projects boldly from the summit of an eminence, and onwards past the grand entrance of the noble mansion, with its stern-looking embattled walls, calling to mind those by-gone days when the "stout Lord Talbot" rode to the wars with all his mighty following of knights, esquires, and men-at-arms.

The principal entrance to the gardens has fine, lofty iron gates, which open out of the park a short distance from the mansion. On the lawn, at the right of the entrance, are many fine Pinuses, among which I noticed a fine *Abies Douglasii*, a *Pinus Cembra*, and some good *Araucarias*. Near these stand

the cenotaph, *fig. 1*, designed from the choragic monument of Lysicrates, of Athens. The bust is that of Charles, sixteenth Earl of Shrewsbury, during whose life these gardens were principally formed. The circular stone at the base of the columns bears the pithy and appropriate legend, "He made the desert smile." The position of this appropriate memorial is well chosen; standing out in bold relief from the dark background of Pinus, it greets the visitor on entering the gardens, and thus the memory of one who did so much for the advancement of horticulture remains evergreen.

The walk from the entrance gates takes a bold sweep past the cenotaph, and on the semicircular space of turf opposite is a small but very picturesque flower garden. Its design is simple; it consists of a large circular bed, belted in front by a row of smaller circles, outside which is a broad ribbon border; next to this is a very broad band of *Cerastium tomentosum*, out of which springs a continuous line or chain of semicircles of that excellent dwarf *Lobelia Trentham Blue*. Next this comes an equally broad band of the dwarf orange scarlet *Pelargonium Harry Hieover*, a perfect sheet of bloom, better than I ever saw it before; then two rows of *Dactylis glomerata variegata*, next *Colens Verschaffelti*, then *Mrs. Pollock Pelargonium*, with *Amy Hogg* inside. This arrangement had a fine effect, and the appearance of the entire border was very satisfactory. The small circular beds contained dwarf bush *Roses*, and standard *Roses* springing out of a fine mass of *Asters* were the occupants of the large circle.

Behind this group is the enclosing wall which passes along from the entrance gates; the form of this wall is so singular as to be worthy of description. Instead of the usual flat surface, the top is built in the form of a number of raised curves, the graceful outline of which is in fine keeping with the irregular undulations of the pleasure grounds. Between each pair of these curves was a vase of suitable size containing a fine mass of scarlet *Pelargonium*, and growing from the ground upwards to the base of the vase was a *Cotoneaster microphylla*, kept pruned to the width of the square base, thus serving to convey the idea of a column on which the vase appeared to rest, altogether present-

ing a very novel and quaint appearance. Along one side of the pathway, running parallel to the

wall, was a broad ribbon border of about 100 yards long, and on the other side a number of detached beds, some of which contained a pretty mixture of *Purple King Verbena* and *Koniga variegata*. The ribbon border was very brilliant with a somewhat complicated mixture of various *Pelargonium*s, *Colens*, *Golden Pyrethrum*, blue *Lobelia*, and *Cerastium*. From here a walk leads directly to the upper terrace, past the grand conservatories, and then to a small circular Grecian temple standing invitingly at the extremity, and which forms an appropriate finish to this pleasant promenade.

Some fine views of the varied and picturesque scenery with which the gardens abound present themselves very agreeably from this point; one of the most striking is that of the Gothic temple, *fig. 2*, a lofty and elegant structure finely situated on the left side of the valley. Wildly beautiful, yet with an air of grace and refinement, is the aspect of the scene before us. Shrubs growing in all the wild

others kept pruned to a more formal outline; vases, statuary, and architectural embellishments, intermingled with bright masses of flowers, or with stately-foliaged tropical plants, and with fountains as varied in force and form as are their situations—some near lofty trees throwing their waters high in the air, the spray glistening in the sunshine, and blown per chance by the breeze among the surrounding branches, a cloud of sparkling mist; whilst others placed in some secluded nook only have a play of a few feet high, but which is quite as charming in its way as that of their more important neighbours—all these are spread around in such profusion as almost to bewilder one.

Let us now turn to the conservatory range, a singular structure, or rather series of structures, 300 feet in length, consisting of a grand central house with a smaller house on each side, and connected with it in one straight line by open corridors, *fig. 3*.

The central part of this striking and novel range has a lofty glass dome, with a smaller one on each side, supported by massive stone columns, the chief recommendation of which must have been their great strength. The sight of these huge

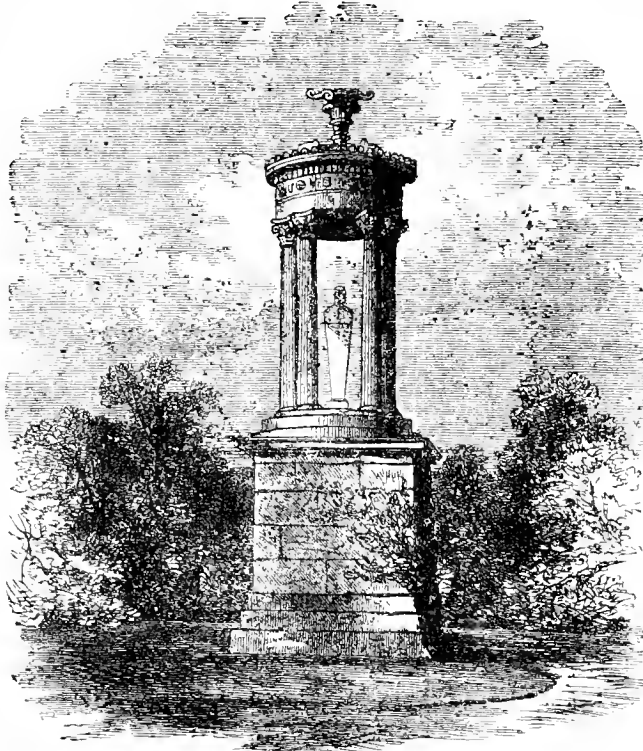

Fig. 1.—The Cenotaph.



Fig. 3.—The Conservatories.

supports reminded one strongly of the great improvements effected in buildings of this description since they were erected, for now by the use of iron columns, strength, lightness, and elegance are combined in such a manner as would astonish the builders of those bygone times. When Mr. Rabone took charge of this place the columns had no embellishment but that given by the hand of the architect. All this is now altered, and instead of appearing bare naked masses of stone, offending the eye, and from which it was impossible to escape in any part of the building, they have become pillars of floral beauty, and rank among its most attractive features. This pleasing change has been effected by covering the entire surface of the sides with mosa mixed with a little rough rich soil, the whole being fastened on with wire. In this covering was growing with great luxuriance a charming mixture of *Caladiums*, *Begonias*, *Ferns*, *Lycopods*, and *Tradescantia*, thus clothing the pillars from floor to roof in a simple but most effective manner. Two fine old Palms—one a variety of Date Palm, and the other a huge specimen of Fan Palm, the bole of which measured 5 feet in circumference—are growing under the large dome in a raised bed, the surface of which is covered with *Selaginella denticulata*, interspersed with a variety of *Caladiums* and *Begonias*, a plant of *Caladium magnificum* being particularly handsome.

Along the front of the corridors there is a uniform row of vases raised on pedestals and well filled with scarlet *Pelargoniums*, alternating with the columns supporting the roofs. Climbing plants cover the back wall of one corridor, and the other is entirely filled with a splendid plant of *Wistaria sinensis* trained on the wall and under the roof; the effect of this must be very fine when the plant is in bloom.

buildings contained a healthy collection of *Camellias* and other hardwooded greenhouse plants.

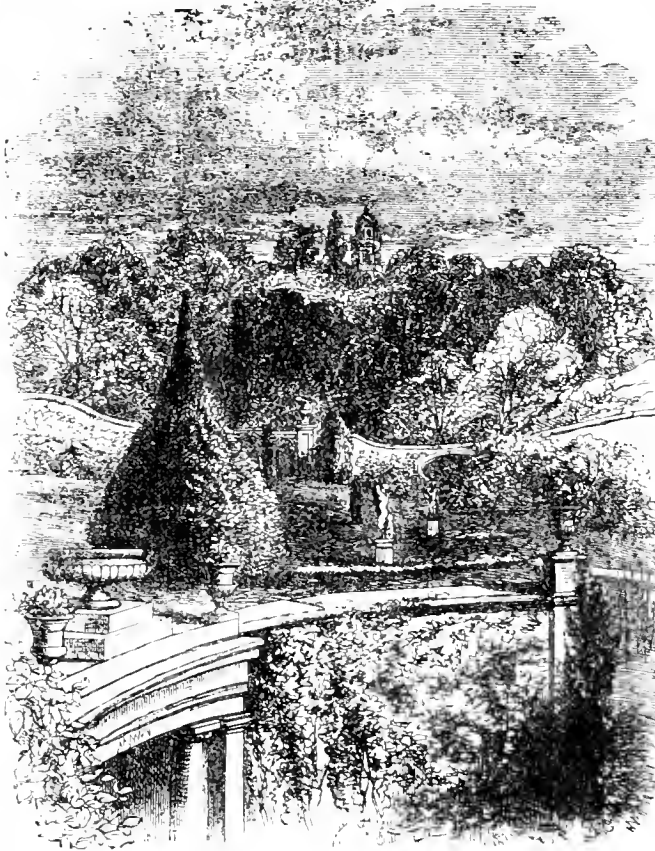

Fig. 2.—The Gothic Temple.

Not far from the conservatoria we come upon one of those pretty scenes of which there are so many here, complete in itself, and yet not unlike many other parts of the grounds in its most prominent features; it is just one of those bright spots on which the eye "loves to linger," and presenting itself suddenly, as it does, in all its brightness and beauty, one is constrained to turn aside to examine and admire. In the background, high up on the bank, stands a long square-shaped house filled with *Azaleas*; in front of this opposite the centre is a fountain having a curved line of tall handsome specimens of *Cypresses* on each side, close in front of which the bank has a perpendicular descent of a few feet faced by a wall. Immediately in front of the fountain, and resting on the top of the wall, is the recumbent figure of a lion, with the water from the fountain passing beneath it down a pretty cascade, with masses of bright flowers on each side, and with the whole abundantly interspersed with vases and statuary.

From this terrace a walk leads upwards to the screw fountain, a singular tapering column of stonework, deriving its name from the spiral hollows winding upwards on its surface; four flat stones encircle this at regular distances, and the water from its summit falls over the edges and passes away under the recumbent figure of an animal down a miniature cascade, which is overshadowed by the boughs of a fine scarlet-leaved Oak (*Quercus coccinea*). From this point the golden gate walk is visible; it is a short terrace walk, having a row of Irish Yews alternating with vases on each side, and there is a stone recess at the end. The bright colours

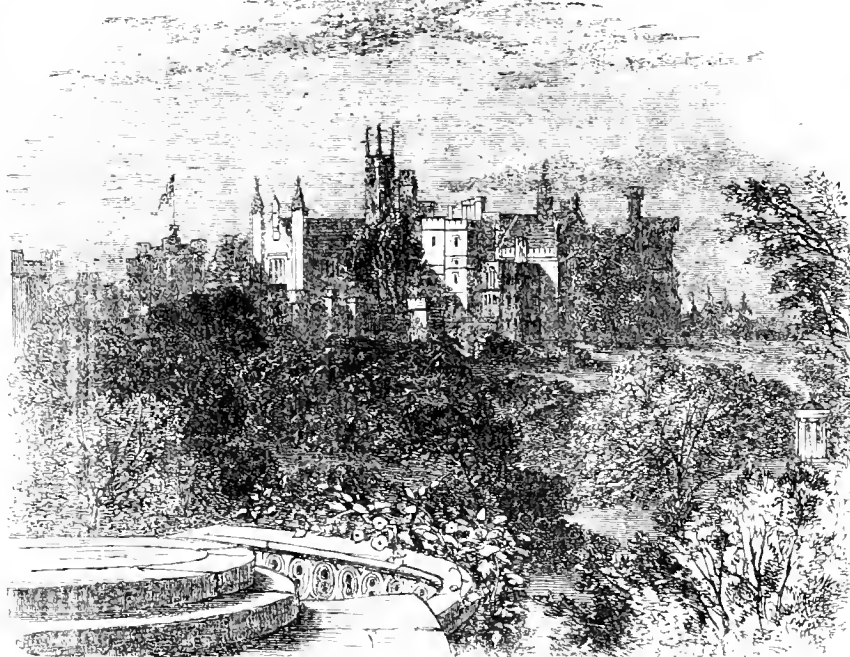

Fig. 4.—Alton Towers from the Gothic Tower.

of a ribbon border running parallel with the walk agreeably con-

trasted with the dark foliage of the Yews. Still ascending the left side of the valley, we come to the rock walk nearly two miles in length, deriving its name from the numerous jutting crags which project over and by the side of the walk at intervals throughout its length. Ferns grow among the masses of rock in great profusion. The abrupt rising of the hillside from this walk, the huge masses of rock and the overhanging boughs of trees, all tend to impart a wild, romantic air of grandeur.

Close to the entrance of this walk, on the top of an archway of rock, are some common Laurels and Yews, apparently growing out of the bare rock, but a closer inspection shows that before the soil in which they were first planted was all washed away by the rains, their roots had struck into the adjoining soil, and so the shrubs continued to flourish. Proceeding up a rude flight of steps, under this archway, along a walk with huge fragments of rock at its sides, up more steps, and we are at the door of the Gothic Temple, then up the spiral staircase leading to the top of this elegant building, whence we have extensive views across the valley to Cannock Chase and the Bagot Woods in the far distance. On the right bank of the valley the Swiss Cottage, an ornamental structure, nestles among the trees; and crowning the eminence near the entrance to the valley is the stately mansion of Alton Towers (*fig. 4*), with its embattled walls, its towers and turrets, its massive dignity impressing one all the more strongly from the commanding position which it occupies, and from the contrast which its huge proportions present to the numerous architectural features of the gardens visible from this point. — EDWARD LUCKHURST, *Old Lands, Buxted, Sussex.*

(To be continued.)

GARDENING IN ALGERIA.

FRUITS are not cultivated as much as might be the case were there improved facilities for exporting them to remunerative markets, though they form, as it is, a very large portion of the food of the people, both in a fresh and in a dried state. The Fig is as important an element in the food of the Kabyle as the Date in the dietary of the Arab. Olives are grown principally in the mountainous region extending between Morocco and Tunis, at from 1200 feet to 2500 feet above the sea; at a less elevation the fruit is not only inferior in quality, but in quantity. That portion of the Atlas range which runs through the province of Algiers produced last year 50,000 tons of the fruit; while during the first quarter of the year upwards of a million pounds of oil were shipped at the port of Algiers alone. The Locust, or Kbaroub tree, is destined to become one of the most important products of Algeria—perhaps for sugar, certainly for feeding cattle. What is very much wanted in this country is some remunerative arborescent culture; and nothing appears better adapted to the climate, or the requirements of the colony, than this valuable tree.

The time is not far distant when Algeria will become an important wine-producing country. It will furnish not only sufficient for its own consumption, but its wine will compete with the finer vintages of France and Spain. The chief faults requiring correction are:—1, The mixture of plants in vineyards; 2, The want of attention to the proper kinds of Vine for each climate; 3, Careless fabrication; 4, Want of proper cellarage; and 5, Precipitation in bottling. Before the French conquest, the natives only cultivated the Vine for the purpose of eating its fruit, and up to the present day they have not improved their defective system of cultivation. Even in European farms much yet remains to be done. The colonists of Algeria, coming as they do from nearly all the countries of Europe, are naturally inclined to introduce the mode of Vine-culture, and fabrication of the wine, with which they were familiar in their own country, without the slightest regard to its suitability to their altered circumstances; this defect is now understood, and will, consequently, be remedied. In the province of Algiers about 17,000 acres are under cultivation with Vines, though a great proportion of the surface is not in full bearing. This area produced during the past year about 1,350,000 imperial gallons of wine, generally strong and well flavoured. The cost of planting Vines varies from £4 to £9 10s. per acre and an annual charge of £2 5s. is required for its cultivation. This ought to produce in the plains about 350 gallons, and in the hills 200 gallons of wine, when the Vines have attained the full bearing age of five years. Raisins have not hitherto been made to any great extent; but attention is being turned in this direction, and one Spaniard has lately planted 100 acres of Vine, entirely for the sake of the dry fruit.

In the same province, in 1867, about 7390 acres were under cultivation as market gardens. Potatoes are one of the principal vegetables produced; the cultivation of these costs about £7 per acre, which area yields in dry soils from 4000 to 6000 lbs.; and in irrigable land from 16,000 to 24,000 lbs., in three successive crops. The production, however, is very uncertain, owing to disease and sirocco, and the seed has to be renewed from Europe every year. Potatoes sown in March, and gathered in June or July, sell at from 6s. 8d. to 8s. 4d. per cwt. Those planted in August and September usually fetch nearly double these sums. Sweet Potatoes produce from 6000 lbs. to 8000 lbs. in dry soil, and from 24,000 lbs. to 32,000 lbs. per acre, in irrigable land. Artichokes yield from 30,000 to 40,000 heads per acre, and sell for exportation to the Paris market at about 2s. per 100.—(*Food Journal.*)

WORK FOR THE WEEK.

KITCHEN GARDEN.

At this period let every inch of spare ground, if time permit, be trenched into sharp ridges. Spare ground to any considerable extent at this season is a sign of bad gardening. Let a good breadth of Cabbage plants be pricked out in rather poor soil; they will all be wanted in spring. Plant a good breadth of half-blanching stout *Endive* plants in every spare frame, also stout half-blanching Cos and Cabbage *Lettuces*. Pot for forcing in winter a stock of herbs, such as Sweet Marjoram, Mint, Sorrel, and Tarragon. Early-ripened *Sea kale* for forcing in dung beds or the Mushroom house may be trenched up with every root entire, and heeled in the compost-ground, in order to be drawn out successively as wanted. Gather *Tomatoes* as soon as they begin to colour, and complete their ripening in-doors in a good dry heat. Examine *Onions* in store.

FRUIT GARDEN.

Give occasional ventilation to the fruit room, shutting up as dry as possible. Gather all remaining Pears and Apples forthwith; if unripe they will receive no benefit out of doors after this period. Attend to the remarks on the removal of fruit trees in last week's calendar.

FLOWER GARDEN.

Choice flowers in the flower garden can no longer be depended on for affording a display; it is, therefore, desirable at this period to look over the masses and beds, and see if there be any plants of a tender character which it is desirable to secure for next year. Such may be potted with balls and wintered in the cold pits. Alterations may be proceeded with, also planting, turf-laying, edging, &c. The time is now arrived when all Tulip beds ought to be properly arranged for planting, so that the bulbs may be placed in the ground not later than the last week in October. Some means also should be adopted to shelter the bed or beds from heavy rain, as it is extremely prejudicial to the bulbs before they have begun to appear aboveground, and, in fact, excess of moisture ought at all times to be avoided. Attention ought likewise to be given to those bulbs of which the spikes have elongated. Aphis or green fly is apt to attack them, and should be carefully brushed off. In obtaining new varieties of Carnations and Picotees the best plan is to purchase them immediately; better plants will generally be obtained now than in the spring, and they will have time to establish themselves before winter. This is very necessary if they are to be kept in a state of health till next spring. Take care that the frames in which Auriculas are to be wintered have a proper pitch, and that all the glass is sound, so that the plants may not be subject to drip, which will be sure to ruin them. A free circulation of air should at all times be promoted, and when properly managed few flowers are more hardy than the Auricula. Pink and Pansy beds, I presume, are already planted. Some of the plants of both are occasionally "long on the leg;" such should be supported with small sticks, or they are apt to be broken over by the wind. After all that has been said about the spring or even midwinter planting of evergreens, I am persuaded that no period of the year can equal the autumn, say from the middle of October until the end of November. Much, however, depends upon the character of the soil as well as on the mode in which the operation is conducted. Some persons advocate puddle-planting, but on what principles I never could discover. Why not puddle-potting? Certainly it is better to puddle a large specimen than to totally neglect it in regard to moisture. The best practice is to open a hole much larger than the ball of earth or volume of roots about to be introduced, taking care not to make the hole any deeper in general than

the surface soil extends; then saturate the subsoil with water, and next thoroughly pulverise the soil intended for filling in round the root. After this is completed rake together a body of tree leaves, weeds, sticks, &c., and throw 3 or 4 inches (sometimes a foot), to the bottom of the hole to set the ball or roots on, putting little or no soil beneath the tree. The tree being carefully removed—not a fibre suffered to dry if possible during the operation—is placed on the leaves, and the process of filling up commences. Decayed vegetable matter is mixed with the soil; this is sometimes obtained on the spot by raking or paring the surface of the ground contiguous. The soil, being in a mellow state, is slightly trodden as the filling proceeds, and when filled level with the ball, or rather above it, the whole receives a thorough watering, using several cans of water at slight intervals. The next business, and a most important affair, is to thoroughly stake the tree to prevent wind-waving. When this is completed a thick mulching of half-rotten manure or leaves will finish the process. Such trees should have one thorough soaking of water in the early part of April, afterwards they may be safely left to themselves.

CONSERVATORY AND GREENHOUSE.

The climbers in the conservatory, at least some of the most rambling, will now want a good dressing where they obstruct the light in any material degree. Such as flower on the young wood, and which are now in a ripening state, or approaching a state of rest, may be pruned-in exceedingly closely. Such as the late-blooming Passifloras, the Combretums, Echites, Ipomoeas, Stephanotis, Thunbergias, Pergularias, and Mandevilla, which are still thriving, must be regulated with a more gentle hand, merely cutting off barren shoots, and drawing the remainder into somewhat closer festoons, in order to admit sunlight to the interior of the house. Some skill will be necessary in the mixed greenhouse, especially at this period; there will be so many candidates for admission that confusion and consequently failures will be inevitable, unless some things be discarded or removed to a cold pit or plant hospital. Better grow a few plants well than many badly. Now that the gems of summer are gone, or are on the eve of departure, let a strict eye be kept on those plants which, although of no botanical interest, are yet of great importance as cheering the mind amid the gloom of winter, when out of doors all appears a wreck. Let all flowering plants be kept near the glass in the lightest situation to be found, and, if possible, let those from warm climates enjoy bottom heat until they commence flowering, when they will do tolerably well without it. Let the stock of Pelargoniums have abundance of air, and sink gradually down into a sort of quiescent state, limiting the supply of water in proportion to the decrease of light. Preparations for hard weather should now be completed. All tender stock intended for protection under glass should be at once placed in winter quarters, plunging the pots, as before observed, in ashes or sawdust. A good supply of garden mats should be immediately provided, for although expensive they must be procured before frost. A good stock of new sawdust should be laid by in a dry shed to put round the stems of tender Roses or half-hardy plants. It should always be obtained as new and fresh as possible, but ought not to be applied to the plants for some time. A dry time should, if possible, be chosen, as a casing of such material immediately after heavy rains would probably be very prejudicial, for confined damp is in many cases a greater enemy than frost. Wooden shutters are very useful, whether to lay on as a temporary framework to exclude wet and the keenest of the frost, or to be employed instead of mats to cover pits and frames.—W. KEANE.

DOINGS OF THE LAST WEEK

The barometer having stood high without moving for the greater part of a fortnight, it fell considerably on the 7th and the 8th, and that with little apparent cause, as but a small quantity of rain has fallen, and there is no great appearance of much more coming, while there is but little wind to account for the change. It has induced us to look about, however, and put things in order.

KITCHEN GARDEN.

Before the rains came we took the opportunity to earth-up at once a lot more *Celery*, so as to come in about three weeks hence, using some burned refuse to go immediately round the stems of the plants. This, with the previous lime-dusting, would help to keep soft-skinned intruders away. Of course this dry rather acid material was quite cold before using it. A very small

quantity does for going round the *Celery*, if short lengths of old semicircular tin or zinc spouting are set round the plants. The earth is filled in in the usual way, using it well broken from the sides, and when sufficiently high the dry fine soil or ashes are put down inside the pipes, and when well pressed the pipes are drawn up, and the soil formed round the ashes. This takes more time than using the finely-pulverised earth alone, but it secures closer, and, therefore, better-looking *Celery*. Though not disapproving of large kinds, we still consider the Dwarf White Incomparable the best for small gardens, it takes up so little room, and requires so little earthing-up. A good plant 15 inches high will produce from 10 to 12 inches of blanched material for the table.

Apprehending rain, some time was devoted to the removal of Pea stakes where the crops were over, and of decayed leaves of vegetables which could not well be pointed-in. We forked the ground slightly among Cabbages, Coteworts, &c., so that the rain should have free entrance when it came, instead of caking the surface and running off. Planted also Lettuces and Cabbages to stand the winter, as the dry weather had deterred us from doing so before, and we scattered a little soot and charcoal dust among young Cauliflower plants, that the fly, so prevalent, should not molest them. It is rather singular how capricious the Cabbage fly is in its tastes. We have a nice piece of the Little Pixie Cabbage in one of our earth pits, where it succeeded bedding plants, and though the little heads are firm, not a fly appears on the foliage. Near to them, and in a similar position, is a bed of the earliest Coleworts heading nicely, but these have been attacked several times with clouds of fly. From our old Cabbage quarter, bristling with young Cabbages, we could not gather a dish without having to wash them well. If the rains do not help us, we shall give a cleaning to the quarter, and then syringe with soot or clear sewage water. The youngest Cabbage plants are the most infested; we have had to syringe and dust them repeatedly with fine soot, to save the little heart-point from the fly's ravages. On the 5th and 6th the air was quite darkened here about 4 P.M. with small flies. We have seen none on Savoys.

Mushrooms.—As we cannot use our Mushroom house, we have turned out the first piece we made in the open shed, and filled again with material for another bed. That piece gave us a fine lot of Mushrooms, but it is hard satisfying us, for we expected it to bear a few weeks longer. On examining it, however, the spawn seemed so run that we had little hopes of what it would do, and more especially as the litter that formed the chief part of the bed had heated itself rather dry. The second piece has been producing several weeks, and the third piece has been spawned and earthed-up. The first piece will now form the fourth succession in the shed. As it will have to produce after the cold weather sets in, we have made the bed deeper—about 18 inches deep at the back, and 14 inches deep in front. It is chiefly formed of litter, wetted sufficiently with sewage to make it heat and sweeten, but not to decay too much, and then surfaced with 2 inches of droppings. This, watched before spawning will, we have no doubt, do well. The roof of the shed, by keeping off wet and snow, renders the management of the bed much easier than if the bed had been a ridge out of doors. Such ridges must be well covered in winter, and in all our district straw will be very scarce this season.

This is a good time to make *Mushroom spawn*, where the cakes can be dried sufficiently before spawning them, but the process all through has several times been described fully. All who are contented with a small bed or two will find it by far the most economical way to obtain their spawn from a nurseryman who takes a pride in sending out a good article.

There is just as much care required to make a few bushels as in making hundreds or thousands of bushels, and it is here that the large spawn-maker can sell cheaper than the small maker. It is quite right to encourage work being done at home for the benefit of the neighbourhood; but provided home work is plentiful, there are many things connected with a garden which can be made more economically by machinery than by hand labour. For instance, we like to see garden sashes made in a carpenter's yard, with the use of the common tools; but no carpenter could compete in the matter of price with sashes where the most of the work was done by steam machinery. More will yet be done by acting on the division of labour principle. The great drawback is that machinery, as in our corn-thrashing machines, does at first lessen the amount of labour required without lessening the number of labourers to be employed.

FRUIT DEPARTMENT.

Proceeded with gathering fruit as it was fit, and now the chief proportion is housed in good order, though a number of the late Pears and Apples are out still. Where trees kept dwarf are rather luxuriant, and the fruit is gathered, a little *root-pruning* should be given without delay. The sooner it is done the more it will be likely to act, not only on the next season's growth, but also on the fertility of the tree. If the roots are cut late in autumn, or during the winter, the luxuriant growth will be arrested next summer, and greater fertility may be expected in the succeeding summer—that is, in 1872. But if the root-pruning is done in the end of September or the beginning of October, and the autumn should prove sunny, the pruning will tell somewhat on the productiveness of the tree the following season. Where there is little or no fruit, the root-pruning may be done earlier. We are not advocates for severe root-pruning at once, but would rather repeat the operation at different times. If the tree is not over-luxuriant, we would out a little on two sides opposite each other, and leave two sides untouched. If the trees are first planted on mounds, and are yearly mulched on the surface, when once in full bearing they will not need much root-pruning, and beyond summer-pruning not much pruning of any sort, as the fruit will almost exhaust the additional strength given by the mulching, and the roots will be encouraged to keep near the surface—a very different affair as regards the results from roots going deep. We should not forget that different principles ought to be brought into operation when we plant an Oak tree for timber and a fruit tree for fruit. When a fruit tree is treated like an Oak tree, a certain age and a certain degree of maturity must be arrived at before the tree produces fruit profusely.

Where *planting* is contemplated, any trouble in preparing the ground early and in fine dry weather will not be wasted. The more the ground is turned up and sweetened by exposure to the air before planting, the better will the trees thrive when transferred to their new quarters. Orchards in the old style, with even grass pastures beneath them, are very useful where large quantities of fruit are desirable. In such cases, and in all cases in general, it is less necessary to trench and prepare the whole ground than to prepare fair-sized stations for the trees to stand upon. Besides sweetening and exposing to the air the soil of these stations, it would be well to elevate them 6 to 12 inches above the general level, so that the tree should eventually have its bole rising out of a swelling mound. This elevation will not cause the tree to grow more freely at first, but it will insure better health and more fertility.

ORNAMENTAL DEPARTMENT.

The flower garden is still so good that we have been forced to mow, machine, and sweep up leaves, and to pick over the beds once more to remove faded blooms and some faded leaves brought on again by the continued dryness. The walks also were rolled after a shower to make them firm, smooth, and bright. The corridors, conservatory, and other places were gone over, and the tenderest plants removed. For glass cases in summer without heat, few things look better up to October from July than good plants of the better-coloured kinds of Calceas. Those removed now, if quite clean, will go at once to the rubbish heap, those infested with any insects to the burning heap, or where the coming cold will kill the whole. We have not room for wintering large plants, and therefore must keep some small ones and grow from cuttings in spring.

All such changing, and cleaning, and fresh furnishing should take place often. The gardener should try to go through his places with the eye of a stranger. It is amazing how apt we are to look upon a house as fresh arranged and fresh done up day after day, when it has been the same for weeks. The eye should, in fact, be more used at home to find out blemishes and imperfections than to be taken up with what is beautiful and interesting. In such cases it is often less a question of more or less work than simply seeing and acting on the sight. Hence a man with little or no more labour, and scarcely more time, will keep a house always presentable, and another man will have it always untidy, except immediately after one of these great out-clearings and fresh-furnishings. The first man, even when doing the necessary watering, will not pass an unsightly plant thoroughly exhausted, nor a plant with a few faded leaves, without removing it, nor will he pour water on every pot alike, just in the way of routine. The other never sees that a plant is faded, never sees the miserable wilted leaves, waters the decaying and the flourishing alike, and if let alone would never move a plant after he had once placed it on a shelf or platform. As a gardener must gain

his living by practising something of taste and order, looking out for untidiness ought to be an every-day and an every-hour operation. Some time ago we walked through a pretty little conservatory, communicating by wide folding doors with a richly-furnished drawing-room. The gardener was an able, intelligent man, but these qualities seemingly did not give him a sense of order or the faculty of observation. The fine stone curbs were slimy green, the stage had plenty of green, the pots were dirty, and though there were many blossoms, they were mingled with fading leaves, and the gardener seemed to see nothing of the discord between all this and the neatly-furnished drawing-room. We could not well venture farther than to move some of the slime from the stone curbs with a walking-stick in rather a contemplative earnest way, but our friend was not observant enough to take the hint. An advice worth having and valuing, we would say to our young readers, Beware of the habit of looking on plants, houses, and borders as just fresh arranged, fresh potted, fresh cared for, when days or even weeks have passed since the work was done. Look at such things as they are to-day without any reference to the past.

Struck Cuttings.—Anticipating rains we have overhauled lots of cuttings for the flower garden, that were thickly inserted in shallow wooden boxes and pots, setting them a little further apart, and removing every decayed and faded leaf. As stated formerly, we are obliged to take small cuttings and put them in thickly together, in order to be able to house enough of them under glass in winter. We find no fault, quite the reverse, with those who take large cuttings and give each a pot in winter. We must suit ourselves to circumstances. As these cuttings, rooting now, are so close together, there is the more reason that not a decayed leaf should rest upon them, as in dull heavy weather a few such leaves festering about the stems would be apt to gangrene and rot them, and, if free air could not be given, the very air about the plants would tend to produce decay. The cuttings thus treated had the surface soil sprinkled over with a mixture of fine sandy loam and charcoal dust, a good security alike for neatness and against damping and unhealthy vapours.

We shall make preparations for taking off our shrubby Calceolaria cuttings by the end of the month, and we find it is of importance giving the cuttings fresh soil, Herbaceous Calceolarias for pots we are potting and pricking-off now. They are most useful for corridors and cut flowers early in summer.

We intended to have alluded to different modes of treating old Geraniums in beds, but the matter has been alluded to, and further particulars can wait for another time.—R. F.

BANISHING FLIES.—The *Food Journal* states that in Belgium the hutchers use, with great success, laurel oil on the door-posts and window-frames for the purpose of keeping away flies. The emanation from minced laurel leaves is rapidly fatal to all small insects. These facts might point to gardeners and housekeepers how to exclude flies from structures where their presence is especially disagreeable.

TRADE CATALOGUE RECEIVED.

Lewis S. Woodthorpe, Munro Nurseries, Sible Hedingham, Essex.
—*Catalogue of Greenhouse and Herbaceous Plants, Fruit Trees, Ornamental Trees and Shrubs, &c.*

TO CORRESPONDENTS.

* * We request that no one will write privately to any of the correspondents of the "Journal of Horticulture, Cottage Gardener, and Country Gentleman." By doing so they are subjected to unjustifiable trouble and expense. All communications should therefore be addressed *solely* to *The Editors of the Journal of Horticulture, &c., 171, Fleet Street, London, E.C.*

We also request that correspondents will not mix up on the same sheet questions relating to Gardening and those on Poultry and Bee subjects, if they expect to get them answered promptly and conveniently, but write them on separate communications. Also never to send more than two or three questions at once.

N.B.—Many questions must remain unanswered until next week.

PATENT (A Young Gardener).—You will ever repent of taking out a patent. Register your invention, and the probability is that you will never be repaid for that small expense.

PEARS FOR NORTH IRELAND (A. M. P.).—Doyenné d'Été, Jarzonelle-Williams's Bon Chrétien, Red Doyenné, Thompson's, and Knight's Monarch. The Noblest Peach ought to succeed with you.

PEACHES NOT RIPENING (C., Essex.).—What the name of the variety is we cannot tell from the unripe specimens, and no leaves—the glands on their stalks are guides in the non-enclosure of Peaches and Nectarines. We think the cause of the fruit falling, though well-coloured, and being tough in flesh, is want of moisture to the roots of the tree; water abundantly, and mulch the surface over the roots. Do the same every summer. The roots of the trees which have ripened their fruit may be nearer the surface, and are, probably, earlier-ripening varieties.

APPLES ON THE POMME DE PARADIS STOCK (J. Scott, Merriott Nursery).—The specimens of Apples from trees grafted on the above stock, are among the finest we have ever seen. The Brockworth Park Pear is a seedling. We are obliged by your note that the Apple called, on page 286, "Eckland Vale," should be "Ecklinville Seedling."

SEEDLING GERANIUM (C. Marsden).—The petals were totally shed; but if the truss had been perfect, we could have given no opinion of the value of the variety as a bedding plant, for that depends quite as much on the foliage and dwarf habit of the plants as on their flowers. There are hundreds having the same-coloured petals as those you enclosed.

BATSHELL SPROUTS (Amateur).—Do not cut out the head or leading shoot. In cutting the side shoots use the largest first.

VINES MILDEWED (St. Bridget).—The leaves and Grapes are destroyed by long-neglected mildew. As soon as you saw the "white powder" on the leaves you should have dusted them with flowers of sulphur. Pick off all the Grapes, dust the leaves thoroughly with flowers of sulphur, paint the stems and branches with a creamy mixture of clay, flowers of sulphur, and water, and sprinkle over the surface of the borders, &c., with flowers of sulphur. As the leaves fall burn them. Next year use flowers of sulphur as soon as the white powder appears, and until it ceases to appear continue applying the sulphur. The white powder is a parasitical fungus, Oidium Tuckeri.

CHARGE FOR PAINTING (Notice).—These are matters we prefer to leave to tradesmen and contractors. It is impossible to tell you what should be allowed for the stopping and scraping old work before painting. If it is in a very bad state the work would have to be allowed for; if not, it would come in with the first coat of paint. As you speak of stone colour and oil, we presume you mean white lead merely toned down a little. For three coats of such paint on a fair smooth surface, about 5d. per square yard would be a just price. In some cases the cost would be more, and in others less. The coats we would value as three, two, one, the first coat always taking up more material. Windows would be less or more according to the number of the bars and the size of the glass. The more cross-bars the more expense. For common-sized squares, the windows should cost quite as much as the plain work. In large squares, and where, as in hothouse roofs, there are no cross-bars, the price should be less. We merely from calculation say what the work may be done for; we cannot tell you where it may be done, but this will be all. All painting is measured by the square foot or yard. All semicircles and angles measure as squares—that is, the greatest length and the greatest breadth. Your windows would be measured just like a wall—by the greatest height and the greatest breadth; thus, a circular window would be measured by squaring the diameter. We know that new garden sashes painted four times cost about 1d. per foot—that is, 9d. per yard, and that would be 4d. per yard for the outside. If you paint your windows inside as well as outside the measurement will be doubled.

MUSHROOMS IN HOUSES MAGGOTY IN SUMMER (A Soldier).—This is a very common occurrence in hot summers where coolness cannot be sufficiently secured. Airiness without draught, and coolness, are next to indispensable to good Mushrooms in summer. Hence the advantage of cellars for summer growth. We have been frequently troubled with maggots, though some summers we have escaped altogether. Much may be done with double or thick walls and a double roof; or, if not, thatch, whitening it after May to keep the heat out. Much also may be done by syringing walls and floors, but it is difficult to grow good Mushrooms in houses easily heated by the sun. We prefer an open shed, or the open air under the shade of trees, but a place underground is best. See what was said at page 261.

WINTERING SCARLET GERANIUMS (Subscriber).—Such fine large plants taken up out of the beds would do best if potted individually, but they will do very well if packed thickly in large pots, or shallow boxes quite as thickly as they will go together, so as to resemble a faggot. If you do not wish your plants to be large you may cut away the shoots 6 inches or so above the collar of the plant; but if you wish to have rather large plants at planting time next year, the best plan is to take them up carefully, cut off all the soft ends of the shoots close to a joint, remove every leaf, dip the cut tops in a dry powder of lime and charcoal to stop bleeding, trim the roots a little, and then pack them as thickly as they will go in rather sandy loam in boxes, &c. We have crammed more than a dozen fine plants in a 10-inch pot. When nicely packed, and as firm as may be, water, so as to moisten the roots and soil, and allow them to stand until the surface soil is dry; then cover with an inch or so of dry soil, and as you cannot give them a place on the greenhouse stage, any dry place will suit them where they can be secure from damp, drip, and frost. They will do anywhere—under the stage of the greenhouse, in spare rooms where there is a little light, in dry cellars, in garrets, or in haylofts, where the frost cannot reach them. In open haylofts we have known them do well where loose hay was thrown over them in frosty weather. The more succulent the stems the more easily are they injured by frost. The roots are more apt to suffer from damp than frost. Hence little boxes of a convenient size, say from 4 to 6 inches deep, are better for packing in than large pots. When so kept it is best not to excite them in winter, but rather let them remain dormant as respects their stems, being content to see them putting forth little leaves after March. When these leaves become larger than a shilling the plants will want thinning out. To make fine plants from such Geraniums, take them up as above, remove all the large leaves, but leave the points untouched. These must have light and better treatment.

HOUSE FOR VARIOUS PLANTS (J. C.).—We think the Tropæolum is doing as well as you can expect at the back of a house with Vines on the roof; and even if there were none, Tropæolums are apt to lose their lower leaves. The *Lonicera* requires plenty of light and air. The back wall of a vinery, such as yours seems to be, is very unsuitable for it and similar

plants. It is better suited for Camellias and Orange trees. All the two plants you name require, seems to be light and air. Ferns, you say, thrive well in the house, that is proof there is moisture and shade; but as some are stove kinds, your only chance of keeping them is to preserve the soil as dry as you can without causing the fronds to flag. Unless the house is very high and wide a flow and return hot-water pipe will be sufficient to keep out frost. We do not understand you as to the trellis-work preventing air passing through. If air cannot pass through, it is not trellis-work at all, but some close material. If the front openings are too large why open them so much? Top air is preferable to so much side or front ventilation. *Canna indica* dies down every winter. It ought now to be kept short of water, and when the leaves turn yellow cut them off, and keep the roots dry in winter and secure from frost. In February repot them, and place them in a hotbed, and when the shoots are a few inches long remove the plants to a light airy part of the house.

PRUNING LAURELS (Tereus).—The most suitable time to prune Laurels, especially when they require much cutting-back, is at the end of March or beginning of April, or when they are beginning to grow; but any irregularities of growth may be removed from August to October. For transplanting Laurels no time is so suitable as the present, for the soil, owing to the late rains, will be moist; if as dry as it was a short time ago planting must be deferred until it is thoroughly moistened. October and November, February and the beginning of March, are good times to plant Laurels.

REMOVING SULPHUR FROM RIPPED GRAPES (T. V.).—Blow off the sulphur by means of a pair of bellows. If it fail, which we have not found, syringe the Grapes a few hours before wanted, to allow of their becoming dry before disking up. Only those required for present use ought to be syringed, for if those on the Vines are syringed the berries will crack, spot, or decay.

PRIMULAS AND CINERARIAS NOT THRIVING (Duncanensis).—We think the Primulas are unhealthy because you syringe them; discontinue it. Do not water until the soil becomes dry, but before the leaves flag; then give a good supply, and do not water again until another watering is required. We cannot account for the Cinerarias drooping. They should be watered as required, and syringed occasionally. Perhaps the plants are infested with thrips or aphides, for which fumigation with tobacco is the remedy. In the position you name they ought to do well.

SOWING SEEDS (Mary).—It is rather late for sowing *Echeveria metallica* and *Pyrethrum* seeds in a hotbed, but you may yet do so if very careful in watering, in giving the plants air, and in keeping them near the glass. Stocks, Delphiniums, Schizanthus, Centaurea, Silene, and Saponaria you may sow now in pots, and keep the seedlings near the glass in a greenhouse. If you keep them from becoming drawn all will be well, but we should have had more confidence of success if you had sown three weeks or a month earlier.

RANUNCULUS PLANTING (Idem).—The sloping border which has been occupied with Geraniums will answer for Ranunculuses. Give a good dressing of rotten manure, dig the ground deeply, and make it fine. Plant in November as soon as the ground can be prepared, and in December mulch with about half an inch of partially-decayed leaves. If the weather be dry in April and May water copiously.

PEA HURDLES (M. S.).—We have used them for years, and find them answer well.

MANURE AND POTATOES REQUIRED TO PLANT AN ACRE OF GROUND (Idem).—Twelve good loads of farmyard manure are a good manuring for an acre of ground, and to plant an acre, ten bushels of ordinary-sized sets are needed. The rows should be 2 feet 6 inches apart, and half that for the sets in the lines.

REPLANTING PANHIES IN THE SAME BED (Idem).—It is not good to replant them in a bed in which they have grown previously. Fresh soil is best. If you manure well, and dig deeply, they may do well.

GRAPES COLMAN GRAPE (Bertram).—This is a very late variety. Bunches large; berries very large, round, jet black, and very beautiful; skin very thick; flesh very coarse, and coarsely flavoured; constitution very robust. It is a Grape which will hang well, and has a splendid appearance, but if without any other recommendation.

MELON DE NAMUR PEAR (H. H.).—Thanks for the example. We must say it seems to us very closely allied to Doyenné Blanc. It is of the same form and colour, the same in flesh, and almost in flavour. The eye, however, is different, being open, and the stalk is longer and more slender. It is a good Pear, but inferior to some others of the same season.

SELECT STOVE PLANTS (Store).—For foliage or variegation: *Alocasia metallica*, *Areca Verschoffelti*, *Calamus asperimus*, *Cocos Weddelliana*, *Croton interruptum*, variegatum, *longifolium*, *Dieffenbachia Pearcei*, *D. Weirii*, *Maranta illustris*, *M. roseo-picta*, *M. Veitchii*, *Pandanus javanicus*, variegatus, *Sanchezia nobilis variegata*, *Thrinax elegans*, and *Verschaffelia splendens*. Flowering: *Allamanda nobilis*, *A. grandiflora*, *Anthurium Scherzerianum*, *Bougainvillea glabra*, *Clorodendron Thomsense*, *Dipladenia amabilis*, *D. crassinoda magnifica*, *D. splendens*, *Gardenia florida intermedia*, *Hoya bella*, *H. imperialis*, *Ixora acuminata*, *I. floribunda*, *I. coccinea superba*, *Medinilla magnifica*, *Rondeletia speciosa major*, *Stephanotis floribunda*, and *Thyreacanthus rutilans*. *Cyathophyllum magnificum* requires in winter a temperature of 60° at night, and from 65 to 70° by day. The soil should be kept as dry as it can be without causing the leaves to flag.

WINTERING GERANIUMS (N. C. H.).—Having no greenhouse, the best place you can give the old plants in the boxes will be the cellar, all or the greater part of the leaves being stripped off. They will not require any water from now until March, when they should be placed in the light, and, if possible, in a frame on a slight hotbed, watering carefully at first, and increasing the supply with the growth. When in the cellar look them over occasionally, removing all decayed leaves. The cuttings would be best in a place where they could have light. A room will answer very well; keep them dry, but if the leaves flag a little water should be given. The old plants will do in the dark cellar.

APRICOT TREES UNFRUITFUL (A Subscriber).—Your trees must be in a poor state, and we think, from the great number of suckers that are formed, that the soil is wholly unsuitable. Clay and bog are not desirable for Apricots. We should take the trees up, cutting all the roots more distant from the stem than 3 feet, and removing the soil, but preserving

all the fibres; you will thus be enabled to cut off the suckers close to their point of origin. Use a compost of fibrous loam, adding one-sixth of old lime rubbish or, what is better, chalk in pieces from the size of a walnut to that of a hen's egg, and do not cover the fibres with more than 3 inches of soil. Mulch over the roots with about 3 inches of littersy manure. The aspect is suitable.

DECIDUOUS TREES FOR A LAWN AND SHRUBBERY (W. G. W.).—Of trees proper, or those which attain 20 feet in height or more, we advise *Acer platanoides colchicum rubrum*, *A. platanoides laciniatum*, *A. rubrum*, *A. pseudo-platanus* (Sycamore) and its variegated forms—viz., *albomarginatum* and *foliis purpureis*; *Aesculus hippocastanum*, and the pink and scarlet-flowering varieties—if you have a wet spot, *Alnus glutinosa laciniata* will suit; *Betula alba* and *pendula*, *Castanea vesca*, and var. *aureo-variegata*, *Cerasus Padus*, *Fagus sylvatica* and var. *asplenifolia*, *purpurea*, and *pendula*; *Fraxinus excelsior pendula*, *Juglans regia laciniata*, *Liriodendron tulipifera*, *Magnolia acuminata*, *M. conspicua*, *M. purpurea*, *Morus alba*, *M. nigra*, *Ornus europæus*, *Populus argentea* for a wet place, *Pyrus communis* and var. *pendula*, *præcox*, and *Bottle-tree*, *P. Malus prunifolia*, *Quercus Robur asplenifolia*, *Robinia pseudo-acacia*, *Salix aurita adnata*, *Salix americana pendula*, *S. babylonica* Kilmarlock Weeping, *Tilia europæa*, *T. laciniata*, *T. sanguinea*, *Ulmus campestris asplenifolia*, *U. fastigiata*, *U. montana crispata*, and the *Campdenowa Elm*.

GERANIUM CONFEDERATE (*One in Suspense*).—Confederate was sent out by Mr. Morse, of Dursley, and raised, we believe, by Mr. Gheny; it is intermediate between Tom Thumb and Little David, and no doubt a seedling of the former, a good bloomer, but not sufficiently distinct to make it worth while to keep it as a separate sort, but it may be used with Tom Thumb.

ROSE'S LEAVES ALMOST BLACK (J. Salford).—The Rose leaf enclosed seemed to us to be suffering from the effects of some deleterious chemical; and we should fancy from its appearance, that during the hot and dry weather at the end of September the leaves of your trees have suffered from the smoke of some chemical works. The wind having been very constant for some time, and the atmosphere very still, any Rose trees situated in the line of the smoke of gas works, agricultural manure or dye works, would be more liable to injury than usual. Although the leaf sent was eaten in places by insects, yet the general injury to the leaf does not seem to arise from insects. We should be glad to learn more, of the position of the trees. Constant syringing with clean soft water, and an occasional application of a little soft soap, will be the most likely remedy.

HEATING A SMALL GREENHOUSE (Grimshy).—A small moveable iron stove, with a flat top to receive an evaporating basin, would be the best for your small house. You should have the stove lined with fire brick, or large enough to have the fire-place in the centre, and a couple of inches or so from the outside iron. You will thus have plenty of heat without the outsides of the stove becoming dangerously hot. You may, as you propose, burn charcoal in such a stove, or, more cheaply, use coke or fine cinders; but in neither case will you succeed unless you have a pipe from the stove going right out of the house. The simplest plan is to have a plate-iron pipe going through the glass roof, a square of the iron with a suitable hole for the pipe taking the place of a square of glass taken out. Regulate draught and consumption of fuel by the asphit door.

MELON AND CUCUMBER HOUSE (*A Lover of Our Journal*).—The plan sketched out will do for Cucumbers and Melons late in spring, in summer, and in autumn; but for winter and early spring use the piping would not be sufficient. In the latter case we would advise having 4-inch pipes in the tank instead of 3-inch pipes, and making the tanks 5 inches deep. The position of the top pipes will do very well, but we would have two instead of one on each side of the house, having one on the side next the pathway. There, too, we would have 4-inch pipes instead of 3, as such a span house will radiate a great deal of heat if no covering is used for the glass. We would, in the case of the tanks as well as the top heat, have the flow pipes next the outside walls. It would be well to have upright open-ended pipes from the tank to admit vapour into the house. Without that you would require evaporating pans on the top flow pipes. The pitch of the roof would answer very well. Were we erecting such a house we would have a double ridge-board, with 8 inches between for a ventilator, and a hood of two boards—A placed over, to let air in and keep out wet.

NAMES OF FRUITS (B. M.).—NONOSUCH. (J. A. Woodlands).—Pears: 1a, Fondante d'Autonne; 2b, Doyenne du Comice; 3c, Winter Nelis; 4, Urbaniste. Apples: 5c, Lord Suffield; 6f, King of the Pippins; 7g, Fearn's Pippin. (F. A. F.).—Apple: Emperor Alexander. (W. B., North Wales).—Apples: 1, Mauks Codlin; 2, Fearn's Pippin; 3, 4, King of the Pippins; 11, Beauty of Kent. Pears: 13, Duc d'Orleans; 14, 16, Beurre Diel; 17, Fondante d'Autonne; 20, Bon Chretien d'Hiver. We must decline to name so many at one time. (William Mills).—The Pear is at present unknown to us. It may probably be Gansel's Bergamot. (*A Subscriber*).—Pear: 21, Marie Louise. Apples: 8, Margil; 11, Downton Pippin; 15, Kerry Pippin; 26, Waltham Abbey Seedling; 78, Court of Wick. (Parcel received from Crediton without Name).—Apples: 1, Cox's Orange Pippin; 2, Early Nonpareil. Pears: 1, Beurre de Rance; 2, Urbaniste; 3, Marie Louise; 5, Glon Moreau; 6, Nutmeg; 7, Van Mons Léon le Clerc; 9, Winter Nelis; 11, Fondante d'Autonne. (Hyke Cross).—Pears: 1, Beurre de Rance; 2, Passo Colmar; 3, Vicar of Winkfield; 4, Doyenne du Comice; 5, Beurre Diel; 6, 7, Knight's Monarch. Apples: 3, Prague; 6, Blenheim Orange. We decline to name more of them. (J. B., West Lodge).—Your fruits, we regret to state, got mixed up with others, so that we entirely lost trace of them. (S. L.).—1, Trumpington; 2, Mauks Codlin. We cannot tell. (Bruno).—Your Apples are unknown. The present is a good time for the removal. (C. W. C.).—2, Bergamotte Cadette; 3, Beurre de Rance; 4, Ord's Apple; 5, Colham. (E. B. K. L.).—1, Beurre Diel; 2, 3, Glon Moreau; 4, Napoleon; 6, Deux Sours. The prickly plant is *Datura Stramonium*. (K. Jenner).—1, Messire Jean; 2, Uvedale's St. Germain; 3, Not known; 4, Grosse Caléasse. (M. H., Acklam Hall).—The Pear is Suffolk Thors. No. 2 Apple, Scarlet Nonpareil; the other two Apples we do not recognise. (M.).—Red Autumn Calville. (J. H., Elmhurst).—1, Grosse Caléasse; 2, Conseiller de la Cour; 5, Red Doyenne; 6, Beurre de Capiaumont; 7, Kentish Filbasket; 8, Mère du Ménage; 9, Stamford Pippin; 11, Golden Russet; 12, Lewis's Incomparable. (J. L. C.).—2, Court-pendé-plat; 3, Claygate Pearmain; 5, King of

the Pippins; 6, Golden Russet; 7, Robinson's Pippin; 8, Yellow Ingestrie; 10, Adam's Pearmain; 13, White Nonpareil; 14, Pitmaston Nonpareil; 15, White Melrose. (Rev. Mr. McCalmont).—The Pear is Hampden's Bergamot, and the Apple we cannot identify, as the specimens are evidently small and uncharacteristic. (E. U., Lyscay).—1, Golden Noble; 2, Drap d'Or; 3, Early Nonpareil; 5, Yorkshire Greening; 6, Augustus Pearmain; 7, Sturmer Pippin; 8, Maiden's Blush; 11, Vicar of Winkfield; 12, Lewis; 13, Napoleon. (W. G.).—Your Grapes are correctly named, with the exception of Muscat of Alexandria, which is White Frontignan; and we have great misgivings about Royal Muscadine, which we think no amount of shade would have altered to the appearance of the Grape you sent us. (W. J. H.).—We are sorry we cannot identify the Pear.

NAMES OF PLANTS (*A Halstead Subscriber*).—You must send fresh specimens, each numbered, or we cannot apply the names. (G. M.).—Ruscus hypoglossum, Double-leaved Encher's Broom. (*A Very Old Subscriber*).—1, *Bonaria edulis*, often called *Alstromeria edulis*; 2, *Acacia decipiens* var. *premorsis*. (H. A.).—Your plant sent in bloom is *Clerodendron fruticosum*, a native of North China. We certainly should not recommend you to allow your Ivy, however ornamental it may be, to entwine itself round the Laburnum. Try to find a less objectionable situation for it. (*A Constant Reader*).—The Crategus sent proved to be *C. coccinea*.

POULTRY, BEE, AND PIGEON CHRONICLE.

POULTRY SHOW REFORMS.

THERE was an article in "our Journal" a short time since on the management of Canary shows. May I be allowed to offer a suggestion or two as to Poultry shows? First, as to catalogues. Now, I take it for granted that every exhibitor at a show, at all events every exhibitor whose entries amount to, say, 10s., is entitled to a ticket of admission; but at every show it happens that there are many exhibitors who cannot be present themselves, but are naturally anxious to learn as soon as possible what success has attended their efforts; and I think in such cases they should be entitled, on returning the admission-ticket to the Secretary before a certain date, to have a catalogue and a list of the prize-winners forwarded to them free by the first post after the award of the prizes. It need not give the Secretary much trouble. Let him procure a number of the halfpenny stamped wrappers beforehand, let him write the addresses on them as the returned tickets come in, let him file them, and when the great day arrives it will not take him long to wrap up the catalogues in them and consign them to the post. It is very annoying to have to wait day after day "in dread suspense," and after all, as has several times happened to me, receive no prize list until it has already been announced in a public journal.

And now as to these same reports, dear Mr. Editor, could you not make them rather fuller and more detailed? In the summer I have often noticed that the poultry portion of the Journal is compressed into a very small compass. Now, I have no objection to that. I am very fond of my flowers, and I look with interest for the reports (and very well written they are) of the great flower shows, new roses, and so on. But in the autumn and winter they are gone by, the poultry shows come on thick, and I taru with equal, or, perhaps, greater interest to the doings in the poultry world. Now, could you not at this time of year take a leaf out of the gardening book and push it back for a page or two? I am sure the value of "our Journal," in a poultry-fancier's eyes, would be greatly increased if we could have more detailed accounts of the poultry exhibited. I do not mean such an account as that of "Wiltshire Rector's" journey to Stroud, in which the journey occupies about ninety lines, the fowls thirty, and the Pigeons eight. (No offence to our good friend, whose letters are always amusing, and whose acquaintance I hope some day to make.) What we want is a more detailed account of the birds and their points. We are not much wiser after reading that "Cochins were good, Game moderate, and Hamburgs poor." We want to know what were the good points of the winners, what the failings of the losers.

I am told that the reports are mostly written by the judges themselves, and if that is so, who is so fit to criticise the different specimens? What disputes would be saved! Breeders would know what points to try for; for there is a fashion in the points of poultry as in most other things. Vulture-hook controversies would not have occupied so much space. Dragon-breeders would know what to do. Fantail-fanciers would not be in doubt whether head or tail was to be the first thing to see to. Turbit-breeders would know whether the turn-crown or the point-head was to be considered "the thing," and so on. If the critiques gave rise to some discussion, so much the better. The reporters, after giving their *ipse dixit*, need take no further part in it, unless they wished.

One word as to pens. I was very pleased at the late Middleton Show to see the large, roomy, well-lighted pens; all quite patterns except those in which the Fantails were boxed-up. They were sadly too small. The poor inmates could scarcely turn round, and as to spreading their tails, that was out of the question.

I think it is one of the first duties of a committee to see that the birds entrusted to their care are made as comfortable in their confinement as possible. I have a vivid recollection of the Variety Duck class at the Hanley Show last winter. The poor unfortunates were not penned at all. They were just set out in a row on the floor of a desolate building, in the hamper in which they had travelled, the lids being set open, and a bit of wire netting fastened on instead. I remember particularly a wretched little Mandarin drake, shut up in a tiny hamper in which he could barely move. There he would be, say, one day on his journey, two days at the Show, and another on his return. Fancy the condition of his beautiful fan feathers after such an imprisonment! Secretaries know beforehand exactly the number of entries, and they ought to provide sufficient and proper pens for all.—SNOOPSHIRE RECTOR.

BREEDING FOR POINTS.

I FIND nearly all fanciers admit it is a great deal easier to breed fine fowls or other poultry lacking in one or two important points, than to breed perfect birds. Hence, one would be very glad to regard his Brahma cock which has fine white neck-buckle as right, because he is so very large and fine; another does not object to ignoring the muff in Houdans; another asks: Are not Aylesburys just as good if their bills are not quite so "pink as a lady's nail?" This will not do. We must not neglect a point because it is hard to breed. If we throw out a point it must be because the best birds, as such, with great uniformity do not possess it, or exhibit it in an unmarked manner.

Within certain bounds, no man can tell what limit to assign to man's power to breed striking peculiarities in birds or animals. Any careful breeder may, if he pleases, establish a breed of fowls entirely distinct from any other known variety. We have half a dozen breeds of some local fame now, but of what use are they? There is no need of multiplying varieties. We should rather strive to reduce the number. For example: The Leghorns are a useful breed, they fill a peculiar place, they are not properly a fancier's breed like the Hamburgs, they lay large eggs, are very tough and hardy, belong to the class of non-sitters, though they not unfrequently sit and make good mothers, yet why should we suffer Leghorns to carry such a variety of points in which variation is allowable? We can find in the same flock single and rose-combed birds; white, pink, and yellow legs; white, bluish-white, cream-coloured, and red earlobes. Why then should we not taboo pink and white legs altogether? If rose-combs ought to be retained, let the varieties be kept distinct. Cream-coloured earlobes usually go with yellow legs.—(Poultry Bulletin.)

ANTWERP PIGEONS.

I HAVE read with much interest a paragraph in your last number headed "Prizes for Antwerp Pigeons." For many years I have been a Pigeon and fowl fancier, and in my time have had Dragons come from all distances, but always preferred Antwerps, considering that they were better breeders, and quite as much, if not more, attached to their homes.

I recollect, thirty years back, the late Sir John Sebright, Bart., who had one of the best assortments of Pigeons, told me he had had given to him two pairs of Antwerps, and after keeping them confined for twelve months, when he had bred sufficient young ones, he allowed them to fly. The old birds, however, even after that lapse of time, returned to their first home, but were sent back to Beechwood Park a few days afterwards, where, I presume, they were incarcerated for a further period, but, I hope, not with hard labour.—G. W. BURROW, 33, Richmond Road, Dalston, N.

THE IPSWICH POULTRY SHOW.—We have just been favoured by a letter from the Honorary Secretary of the Ipswich Show, showing the intention on the part of the local committee to hold the annual meeting on the 17th and 18th of November

next; and also it is stated, that by means of many additional silver cups and considerably increased money prizes, it is intended to give great inducements to exhibitors. Full particulars will be issued in the course of a few days in the printed prize schedule of the Society, and also by advertisements in the public newspapers. Knowing the excellent arrangements of the former Ipswich shows, and the special care taken of the poultry sent for competition, we are glad to find the announcement of a contemporary that this show was defunct is without foundation, and hope all success may be ensured to the coming show.

LONG SUTTON POULTRY SHOW.

For this annually-increasing Poultry Show a shed entirely of wood, 100 yards in length by 20 yards in breadth, was erected. This arrangement, combined with the Messrs. Turners' show pens, placed the Exhibition held on the 5th and 6th inst. in a very favourable position for public view. It is a matter of congratulation that so important an increase has taken place in the competition at this local Show during the few years it has been instituted. As Long Sutton is not one of the easiest of places to transmit specimens to, this result may be ascribed to the public confidence inspired by the careful attention given by the managing Committee. The weather was very favourable, and the attendance of visitors resulted in an unusual amount being taken for admissions.

The *Cochins* were extraordinarily good, more particularly the hen and pullets; Lady Gwydyr, Mr. Lingwood, and Mr. Dutton showing pens in first-class condition. The *Grey Dorkings* were not so good as on previous occasions. *Dark Brahms* were very strong and capital classes. Never need a better display of *Hamburgs* be brought together, and certainly an improved prize schedule for these breeds is deserved. Though so limited in numbers, very excellent *Game fowls* were shown, the Brown Reds of Mr. Laming being the cup-winner. The Black Red Game *Bantams* were not so perfect as at most previous meetings, but the Brown Red and the Red Pale Bantams were decidedly improved. Good Sebright and Pekin Bantams were shown in one general class.

Pigeons have rarely formed better classes at any exhibition in the locality, the Barbs and Carriers especially. Almonds, Pouters, and Toy Pigeons were well represented. *Rabbits* were numerous and good.

Mr. Hewitt judged the poultry, Mr. Tegetmeier the Pigeons, and Mr. Hutton the Rabbits.

THE Pigeons were the best collection we have ever seen since the Crystal Palace Show. In old Carriers Mr. Fulton won the cup and all the prizes, save one by Mr. Massey, who also showed an unnoticed couple of Black hens, which we think deserved a better fate. In young Carriers between twenty and thirty kinds competed—a sufficient proof, if any were wanting, that prizes for young Pigeons as well as old will before long be the rule and not the exception. The first prize went to a Dun from Mr. Massey, the second to Mr. Holt for a good Black. They were a very good lot, and gave the Judge some trouble. In Pouters Mr. Fulton again won all the prizes, save one by Mr. Harvey. For Almonds the cup went to Mr. P. H. Jones, who had a pair in good feather, but a wry-banked hen ought to have kept them out of the prize list, as there were other good birds, notably a pair belonging to Mr. Stanley, not noticed, on account of being in the moult, we presume. In the class for Tumblers of any other variety the prize went to Yellows. Jacobins were fair. Fantails were good and plentiful, but in Owls the cup was won by the best pair we have seen. Turbits were not out of the common. Of Barbs there were some good birds, Captain Heaton winning both prizes, but closely pressed by a very good pair of Blacks from a new exhibitor of this breed, Mr. Ord. Of young Barbs there were also some very good birds; but several exhibitors sent two cocks instead of a pair, which, we hear, as well as showing old for young, will be treated with a strong arm at the Palace Show. The first prize went to Captain Heaton for a very ancient-looking cock, the second to Mr. Walker, and the extra second to Mr. Frank Smith for a couple that had evidently had their lower beaks cut. For Dragons the prizes went to Blues and Yellows; and in the class for Any other distinct variety there were good birds of all sorts.

In Rabbits, for the best Lop-eared, Mr. Easton won the cup with a very good specimen. Mr. Hansen won in Silver-Grays, though we preferred those shown by Mr. Roys.

DORKINGS.—Cock.—1, F. Parlett, Great Baddow. 2, B. Dawson, *hc*, H. Woods, Mansfield; Mrs. Seamons, Aylesbury; S. H. Stott, Rochdale. *c*, J. White, Warlaby. *Hens or Pullets*.—1, Hon. H. W. Fitzwilliam, Wentworth Woodhouse. 2, O. E. Cresswell, Idmworth. *hc*, H. Woods; B. Dawson, Leybourne; G. Clarke, Long Sutton; H. Savile, Rufford Abbey; F. Parlett; Henry Lingwood, Barkin, Needham Market.
COCHINS.—Cock.—1 and Cup, Lady Gwydyr, Stoke Park, Ipswich. 2, Horace Lingwood. *hc*, H. H. Bletsoe, Barnwell, Oundle; Henry Lingwood. *c*, W. Sandby, Badchiffon-Trent; C. Sidwick, Ryddlesden Hall, Keighley; H. H. Bletsoe. *Hens or Pullets*.—Cup, Henry Lingwood. 2, J. Dutton, Ipswich. *hc*, Lady Gwydyr. *hc*, W. Sandby; C. Sidwick; H. H. Bletsoe; J. K. Fowler, Aylesbury; Mr. J. Clarke, Long Sutton; J. Cattel; J. Siebel; Horace Lingwood, Crofting, Needham Market; J. Watts, King's Heath, Birmingham. *c*, Mrs. A. Woodcock, Bursley, Leicester.
BRAHMS.—Cock.—1, Horace Lingwood. 2, G. F. Whitehouse. *hc* Dr. H. Haines, Whiteches, Chesterfield. *Hens or Pullets*.—1, J. Siebel, Lark Hill, Timperley. 2, Lady Gwydyr. *hc*, J. Watts; G. F. Whitehouse, King's Heath,

Birmingham; J. K. Fowler; J. Thompson, Netheredge, Birmingham. c. Dr. Holmes.

SPANISH.—Cock.—1, J. Mansell. 2, E. Brown. hc, H. Beldon, Bingley. Hens or Pullets.—1, F. James. 2, H. Beldoo. hc, E. Brown.

HAMBURG.—Gold or Silver-spangled. Cock.—1, H. Pickles, jun., Earby. 2, T. May. hc, Miss C. E. Palmer; A. Woods; L. Wren; S. S. Mossop; T. Walker, jun., c. T. Walker, jun. Hens or Pullets.—1, G. C. Holt. 2, T. Walker, jun. hc, Miss C. E. Palmer; A. Woods, Setton, Liverpool; G. C. Holt; W. Adams, St. Clements, Ipswich; S. S. Mossop; T. Walker, jun.; H. Beldon; Ashton & Booth, Mottram; H. Pickles, jun.; H. Yardley, Birmingham. Gold or Silver pencilled.—Cock.—Cup and 2, H. Beldon. hc, J. Preston, Allerton; H. Pickles, jun.; W. K. Tickner, Ipswich. c. A. Woods. Hens or Pullets.—Cup, H. Beldon. hc, H. Pickles, jun. hc, A. Cole, Long Sutton (2); H. Beldon; R. Parker; H. Pickles, jun. c. J. Preston; A. Woods.

GAME.—Black-breasted or other Reds.—Cup and 1, J. Laming, Spalding. hc, E. Bell, Burton-on-Trent; J. Preston; S. Matthew, Stowmarket. Any other Variety.—1, S. Matthew (Duckwing). 2, J. Laming.

BANTAMS.—Black or White.—1, G. Clarke. 2, S. & R. Ashton. hc, S. S. Mossop; T. C. Harrison, Hull. c. S. & R. Ashton; T. Dyson, Halifax. Any other Variety.—1, S. Lowndes (Pekin). 2, T. C. Harrison (Silver-laced). hc, T. C. Harrison (Gold-laced); H. Beldon (Pekin and Dresden); H. Draycot, Humberstone (Japanese); H. Yardley. c. Rev. A. G. Brooke, Ruyton XI-Towns (Maltese); J. Watts. Game.—Black-breasted Red.—1, E. Steel, Stump Cross, Halifax. 2, G. Maples, jun., Wsvertree, hc, W. Adams; F. Steel; W. F. Entwisle, Cleckheaton; T. Barker; H. Shumach; G. Maples, jun.; J. Eaton, Farnfield. Brown-breasted Red.—Cup and c, W. F. Entwisle, 2, H. Shumach. hc, W. Greaves, Bradford. Any other Variety.—1, W. F. Entwisle (Duckwings). 2, H. Shumach. hc, W. F. Entwisle; J. Eaton (Pile).

ANY OTHER VARIETY.—1, H. Beldon, jun. (Black Hamburgs). 2, Mrs. E. Cross (Creve-Coeurs). 3, H. Pickles, jun. 4, Hon. H. W. Fitzwilliam (Creve-Coeurs). hc, G. T. Phillips (Houdans); G. Sidwick (Black Hamburgs); Hon. C. W. Fitzwilliam (La Fêche); H. S. Fraser (Houdans); W. K. Patrick, West Wynch, Lynn (8) (Polands); Rev. A. G. Brooke (Malay); J. O. Hobson (Creve-Coeurs); S. S. Mossop; J. K. Fowler (French); H. Beldon (Polands); J. J. Malden (Creve-Coeurs); W. H. Tomlinson (Buff Polands); T. Dean (White-crested Black Polands); c. H. Savile (Japanese Silkies); Mrs. Seamons (Silkies). ORNAMENTAL VARIETY.—1, H. Beldon, jun. (Gold Pheasants). 2, and c. H. Savins (Young Silver Pheasants and Silver Pheasants). hc, E. S. Lowndes, Stony Stratford (Gold Pheasants); Miss M. Dodson (Australian Shell Parrots); J. Watts (Silver Pheasants); H. Savile (Gold Cock Pheasants); S. S. Mossop (Foreign Birds); J. K. Fowler; J. Nutt, Long Sutton (Bengal Parrot); G. Clarke (Gold and Silver Pheasants).

TURKEYS (Any Variety).—1, G. R. Pearson, Witham Common. 2, M. Kew, Marks Overton. hc, E. Leech; G. R. Pearson. c, T. M. Derry. DUCKS.—Rouen.—1, H. Beldon, jun. 2, J. White. hc, A. Woods; J. K. Fowler; W. H. Robson, North Riston, Louth (2). Mrs. Clarke (2). Aylesbury.—1, E. Leech. 2, Mrs. Seamons. hc, J. K. Fowler; Mrs. Seamons. Any other Variety.—1, A. J. Trickett (Carolinias). 2, S. Burn, Whitley (Black East Indian). c, S. & R. Ashton (Shell); T. C. Harrison; F. E. Schofield (Black East Indian).

GESE (Any Variety).—1, Rev. G. Hanter, Stillingleet, York. 2, Mrs. Seamons. hc, E. Leech, Rochdale. c, J. H. Barker (Grey).

SELLING CLASS (25).—1, H. Beldon, hc, F. Parlett (Coloured Dorking); E. Brown (Spanish); G. Clarke (Dorking); c, A. J. Trickett (East Indian); C. Layland (Brahma); G. Clarke (Dorking); J. Stephens (Cochins). (27).—1, H. Pickles, jun. (Polands). 2, Mrs. E. Cross (Creve-Coeurs). hc, J. Preston; W. J. Woodhouse; H. Beldon; W. P. Entwisle; W. K. Tickner (gold-pencilled Hamburgs); S. Beighton (Black Red Bantams).

COUPLE OF FOWLS ON DUCKS.—1, S. S. Mossop. 2, G. Clarke (Cross between Dorking Cock and Partridge Cochins Hen). hc, T. E. Cole; G. Skelton (White Cochins and Coloured Dorking); T. M. Derry (Partridge Cochins and Dorking); G. Clarke. c, T. M. Derry.

PIGEONS.

CARRIERS (Black).—Cock.—1 and 2, R. Fulton. hc, W. Massey, Spalding; J. C. Ord, Pimlico. H. Yardley; F. Smith. c, S. Campanin, jun. Hen.—Cup, 1, and 2, R. Fulton, Deptford. hc, T. W. Metcalfe, Cambridge; R. Fulton. c, F. Smith. Any Variety.—Cock.—1, R. Fulton. 2, W. Massey. hc and c, J. C. Ord. Hen.—1 and 2, R. Fulton. Young Birds.—1, W. Massey. 2, G. C. Holt.

POUTRES (Red or Blue).—Cock.—1, 2, and hc, R. Fulton. Hen.—1, 2, and hc, R. Fulton. Any other Colour.—Cock.—1 and hc, R. Fulton. 2, W. Harvey. Hen.—1, 2, and hc, E. Fulton. c, W. Harvey.

TUMBLERS (Almond).—Cup and 1, P. H. Jones, Fulham. 2, J. H. Ivimy, Singfield. hc, F. Key, Beverley; R. Fulton. Any other Colour.—1, R. Fulton (Yellows). 2, W. J. Woodhouse. hc, F. Graham (Beards); W. J. Woodhouse (Baldheads); J. H. Ivimy (Yellow Agates).

JACOBS.—1, T. C. & E. Newbitt. 2, R. Fulton. hc, R. G. Sanders, Leven, Beverley.

FANTAILS.—1 and 2, J. T. Loversidge, Epworth. hc, F. Graham, Birkenhead; H. Yardley; F. Smith. c, W. Harvey; H. Beldon.

OWLS.—1, R. Fulton (White). 2, W. Harvey, Sheffield. hc, P. H. Jones; J. Fielding, Rochdale. c, S. A. Wyllie.

TURBITS.—1, T. C. & E. Newbitt, Epworth. 2, E. T. Drew (Silver). c, G. H. Gregory, Taunton (Blue); R. D. Borne, Boston.

PARBS.—1 and 2, H. Heaton, Worsley. hc, J. C. Ord; J. Fielding, jun. Young Birds.—1, H. Heaton, Worsley. 2, E. Walker. Extra 2, F. Smith. hc, W. Massey.

DRAGONS.—1 and 2, F. Graham.

ANY OTHER VARIETY.—1, G. Sturges (Egyptian Swifts). 2, H. Beldon. hc, F. Graham; I. Fulton; Lady F. Bushby (Blue Runts); W. Harvey; S. A. Wyllie (Rouets); T. C. & E. Newbitt; H. Snaushall, c. — Arkwright (Autwcrps).

SELLING CLASS.—1, G. Roper, Croxson (Jacobins). 2, H. Beldon. hc, G. H. Gregory; H. N. Harvey (Barbs); J. Watts (2); W. Harvey; H. Yardley.

RABBITS.

LOP.—1 and Cup, A. H. Easton (Black and White Buck). 2, J. Irving. hc, A. H. Ersted (Portsmouth Doe); J. Priestly (Fawn Buck); C. Gravill, jun. (Blue); H. J. Tomlinson; E. Vaughan, Birmingham (Yellow and White Spanish Buck); T. Mumbly (Yellow and White Buck); J. Boyle, jun.

ANY OTHER PURE BREED.—1, S. G. Hudson. 2, J. Preston (Himalayan). hc, E. E. M. Roys, Rochdale (Silver-Grey); A. H. Easton (Silver-Grey); K. S. Rothell, Rochdale (Himalayan); S. G. Hudson, Hull (Silver-Grey); J. Boyle, jun. (Himalayan and Grey and White Dutch).

HEAVYS.—1, Mrs. Arkwright (Yellow and White Doe). 2, T. Mumby, Long Sutton (Grey and White Doe). hc, A. H. Easton (Doe); S. Butterworth. c, J. Taylor; E. Vaughan (Grey and White Spanish Doe).

SUBSCRIPTIONS TO THE FRENCH VARIETY CUP AT SOUTHAMPTON.—Mrs. Leopold Paget, 5s.; Mrs. Pattison, 10s.; Miss T. K. Barnes, 5s.; the Rev. N. Bidley, 10s.; the Rev. J. Ward, 5s.; Mr. R. B. Wood, 10s.; Mr. W. O. Quibell, 5s. Total—£2 10s. Any further subscriptions will be thankfully received by H. S. Fraser, Esq., Headley, Liphook, Hampshire.

THE NATIONAL PERISTERONIC SOCIETY.—The meetings for the season 1870-71 will be held at the Freemasons' Tavern,

Great Queen Street, Lincoln's Inn, from 8 to 10 P.M. on November 1st and 15th, December 6th and 20th, January 3rd and 17th, February 7th and 22nd, and March 1st. Visitors are admitted by a member's card, or by writing to the Honorary Secretary, Mr. P. H. Jones, 37, High Street, Fulham, S.W.

TONBRIDGE WELLS POULTRY SHOW.

This Show was held on the 7th inst., and surpassed any previous, shows that have been held here. About 130 pens were exhibited, and next year the Show is to be larger and pens are to be provided, as this year each exhibitor had to find his own pen, which rather diminished the number of entries; nevertheless, the birds were mostly very good specimens, and in some classes the competition was severe.

Spanish headed the list, and a very good class they were. Dorkings, also, were well represented. In Brahmans, Darks were first, Light second, in a generally good class. Hamburgs, for the south, were well represented; the prize pens were all good, and the competition was large. Game were fairly shown, and the first-prize pen excellent; hardly any of the specimens were dubbed. The French class was fine. The first-prize pen came from North Wales. Mr. Dring's Creve-Coeurs seemed well worthy of a commendation, but they had not this honour; his second-prize Houdans promise to be future prizetakers. In the "Variety class" Silkies were first, White Cochins second. This was a large class. The Ducks were all good. The Aylesburys were first-class. Miss Hawler's Pervian drake must have been very early hatched indeed, quite on the daybreak of the 1st of January, as for an 1870 bird he seemed to be in very forward plumage.

There was a fair show of Pigeons. Mr. Yardley showed a pretty collection of six pairs of different kinds. Below is the prize list:—

SPANISH.—1, F. James, Peckham. 2, E. G. W. Stratford, Addington Park, Maidstone. c, F. C. Horv, Tonbridge. DORKINGS.—1, G. Field, Ashurst, Tonbridge Wells. 2, A. Arnold, Lamberhurst. 3, E. G. W. Stratford, c, J. Field, Tonbridge Wells. BRAHMANS.—1, E. G. W. Stratford. 2, H. Mitchell, Catford Bridge, Sussex. c, Miss Kelsey; W. Dring, Faversham. HAMBURGS.—Golden-spangled.—1, W. Taylor, Maidstone. Golden-pencilled.—1, R. S. S. Woodgate, Fennybury, Tonbridge Wells. c, W. Taylor; R. S. S. Woodgate. Silver-pencilled.—1, Mrs. Miller, Tonbridge Wells. Silver-spangled.—1, W. Taylor. c, J. Lopwirth. GAME.—1, Mrs. Lee, Peshurst. 2, J. Jeskin, Eltham. 3, E. G. W. Stratford. c, Earl of Aberghavony. FRENCH.—1, Miss E. Williams, Welshpool. 2, W. Dring. ANY OTHER VARIETY.—Chickens.—1, Miss Hawker, Tonbridge Wells. 2, K. S. S. Woodgate (White Cochins). Adults.—1, J. Field. 2, Mrs. Miller. c, R. S. S. Woodgate (White Cochins). BANTAMS.—1, E. G. W. Stratford (Game). 2, A. C. Ramsden, Ashurst (Japanese). c, F. Hore. TURKEYS.—1, Sir D. Salomons, Barts, M.P., Tonbridge Wells. 2, J. Patchett, Mayfield, Sussex. GESE.—1, A. J. Borsford, Hope, M.P., Redbury Park, Kent. 2, G. Reid, Broadwater, Sussex. DUCKS.—Aylesbury.—1, G. Wax, Frant, Sussex. 2, Mrs. C. Roberts, Frant. c, F. Edgell, Honen.—1, A. Patchell, Mayfield. 2, Rev. R. Hull, Frant. Any other Variety.—1, Mrs. Lee. 2, Miss Hawker. c, A. Patchett.

PIGEONS.—1, H. Yardley, Birmingham. 2, A. A. Meersch, Catford Bridge. Extra 2, G. Ware. c, Mrs. C. Roberts.

Mr. M. Headley, of Redhill, was the Judge.

SCARBOROUGH CANARY SHOW.—Do not forget the entries close on the 15th. The schedule is comprehensive though somewhat condensed, but by liberal support the Committee will be encouraged to extend their prize list next season. It is the second annual exhibition, and I hope will become one of the permanent fixtures in the "northern circuit."—W. A. B.

HISTORY OF THE BRAHMAS.

I GIVE below all the facts relating to the early history of the Brahma Poetra fowls I can call to mind at this late day. At an earlier day I could have given a history of these fowls more satisfactory to myself—i.e., more fully than I can now; nevertheless, so far as it goes, the truth of it cannot be questioned.

1st, Mr. Chamberlaine's Christian name is Nelson H. 2nd, The sailor's name I never made a note of, and cannot give it.

3rd, The ship arrived in New York in September, 1846. The first brood came out in May, 1847. I purchased the most of that brood in August, and the old pair the April following.

4th, The name of the port from which the ship sailed with the fowls on board is Luckipoor. This port is up from the mouth of the Brahma Poetra river, in India. The name of the ship I cannot give, neither can I give the name of the captain. Did not at the time think it of importance, and made no record of it.

5th, The Brahmans were first exhibited in Boston by Mr. Hatch, of Hampton, Conn., under the name of Grey Chittagongs, in 1850. I declined exhibiting mine at that time: I believed them to be a breed different from the Chittagong, and preferred to accumulate stock and test them further before bringing them out publicly.

6th, I attended the exhibition at Boston, and contended that

they differed from the Chittagongs, and should pass under a different name. A committee was appointed, and the name Brahma Pootra given; it being the name of the great river from the banks of which they came. The name was then established.

7th, Weight of cocks, fall-sized, 12 to 14 lbs.; cocks, six to seven months, 9 to 10 lbs. Hens when first introduced 9 to 10 lbs.

8th, I did notice the "pes-comb" on the first birds. It was small. It was not so with all, and yet it appeared different from the comb of the Chittagong.

9th, There was no degeneracy in the birds of my breeding. I had some specimens larger than the imported birds. I sold no birds until December, 1850. I sold at first at 12 dolls. per pair, and soon after from 15 dolls. to 50 dolls. per pair. The price went up as the fowls became better known, and recognised as a distinct breed.

10th, I bred them eight years, when my health failed, and I was obliged to leave all care for a time.

11th, There was a tendency to throw dark chickens, but a greater tendency to become lighter, and yet not white like the White Dorking. All breeds of fowls having dark and light feathers can be varied either way to darker or lighter by choosing always the darkest or the lightest for breeders. If our stock of Brahmas is pure and they are allowed to breed together promiscuously, the variation in colour will be slight. I never bred to either extreme.—VIRGIL CORNISH—(*Poultry Bulletin.*)

THE NEW METHODS OF CONTROLLING THE FERTILISATION OF THE QUEEN BEE.

REFERRING to Mr. Dax's method of controlling the fertilisation of queens, Mr. Kohl, a bee-keeper of Arnstadt, Thuringia, makes the following statement.

"On the 17th June, 1868, Mr. H., a tailor of B—, whom I know to be a thinking and able bee-master, related to me as follows:—

"Last July one of my colonies (which are all domiciled in Dzierzon hives), which I had purposely deprived of its queen, hatched out a young one. I instructed my son, a young man nineteen years of age, and by no means inexperienced in bee-keeping, to watch the bees carefully during my absence in church, and to pay especial attention to this particular hive, the young queen of which I had not yet seen, but whose existence was according to my calculations perfectly certain, and who might possibly take a wedding flight during my absence. On my return my son informed me that the young queen had made her appearance on the alighting-board, and had attempted to take wing, but had fallen down and was still crawling about in the sand. I immediately sought for and found her, when I discovered to my extreme chagrin that although her wings were fully developed, she was perfectly unable to fly. From sheer pity I allowed her to crawl from my hand into the hive. The next day she reappeared, repeated her vain efforts to fly, and again fell to the ground. I took her up as gently as before and examined her minutely, but failed to discover the cause of her incapacity. I observed symptoms which determined me to make an experiment with her.

"For this purpose I confined her under a large tumbler, together with ten drones from another hive. About ten minutes afterwards I looked at her again, and saw evidence that fertilisation had taken place, and could only regret that I had not kept a constant watch upon her. I replaced her in her hive, and three days afterwards I satisfied myself that she was still there, and that to my extreme delight she had commenced egg-laying. From that time the colony increased rapidly, and is now one of my strongest stocks, although still retaining the same queen.

"After this accidental discovery I made a further experiment in April, 1868, being induced to do so by the possession of a stock which had become queenless during the winter. This I supplied with a brood comb so as to enable it to raise a queen, the fecundation of which appeared possible even so early in the season, since I had already found several drones in another hive. When the young queen had hatched out, I placed her with a few drones under a tumbler, where I left her for a quarter of an hour, and saw that in this case also fertilisation had taken place. Both stocks, with queens which have been fertilised under tumblers, are at this moment in the most

flourishing condition, as may be witnessed by anyone who likes to pay a visit to my apiary, and to whom I shall have pleasure in opening my hives and submitting them to inspection."

HOW LONG ARE YOUNG QUEENS IN EMBRYO?

I HAVE read with very great pleasure the various letters which appeared in your columns from the pens of the "DEVONSHIRE BEE-KEEPER" and Mr. Pettigrew on the question "How long are young queens in embryo?" The "DEVONSHIRE BEE-KEEPER" maintains that sixteen days are required for hatching, while Mr. Pettigrew holds with equal tenacity that fourteen days only are necessary for this purpose. I have to congratulate both writers on the fine spirit they show, the evident love of fairplay which characterises their letters, and their earnest desire to arrive at the truth; and while each holds to his own opinion with great firmness, yet I believe great good will be the result by leading others to examine for themselves.

I was anxious to know the opinions of other authors on this rather important matter, and referred to Langstroth "On the Honey Bee," where, at page 46, he says, "The respective stages of the royal bee are as follows: she passes three days in the egg, and is five a worm. The workers then close her cell, and she immediately begins spinning her cocoon, which occupies her twenty-four hours. On the tenth and eleventh days, and a part of the twelfth, as if exhausted by labour, she remains in complete repose. Then she passes four days and a part of the fifth as a nymph." It is on the sixteenth day, therefore, that the perfect state of queen is attained. But at page 66, where he speaks of artificial queen-rearing, he says, "In from eleven to fourteen days they are in possession of a new queen, in all respects resembling one reared in the natural way." So that Langstroth and the "DEVONSHIRE BEE-KEEPER" are agreed as regards rearing by the natural way.

I then opened a somewhat portly volume, Huish on "Bees: their Natural History and General Management," but his chief object is evidently to treat with scorn and contempt the various opinions advanced by Huber, who, perhaps, has done more than any other individual for the advancement of apian science, and who has been very properly named "Prince of Apianians." According to Huish the egg of the queen takes about twenty-two days from the time of its emission from the ovary of the mother queen until the insect arrives at its maturity. See page 80 of his work.

Having now had considerable practical experience, and devoted much time to the study of this branch of rural economy, as well as from frequent observations made in the rearing of queens, both naturally and artificially, I am convinced that, as a general rule, the time occupied in hatching is under sixteen days.

I will now place before your readers my latest experiment on this matter. Being desirous to introduce fresh blood into my apiary, which all bee-masters should occasionally do, I applied to a friend, some thirty miles distant, to see if he could accommodate me with a frame containing eggs, in order that I might raise for myself young queens. This he willingly acceded to, and on the evening of the 17th of August my longed-for treasure arrived, and on the following day, the 18th, was transferred to a hive which contained neither queen nor eggs. On the 23rd I found six cells completely sealed over. Again on the 26th I had another inspection, and found two cells additional, or eight in all. Next day, the 27th, I was under the necessity of going to Arran to take some honey from my hives there, and during my absence I left them under the charge of a friend, in whom I had confidence, and whom I will now allow to speak for himself. "Early on the morning of the 29th (or the eleventh day) I opened your hive containing queen cells, and to my great surprise found two cells empty; one of the queens I found running stealthily along the combs, the other, as was to be expected, I found dead on the bottom of the hive. On the following morning, the 30th (or the twelfth day), I found two more hatched, one on each side of the comb, both alive, but one of them, being weakly, soon died; the other was engaged in a violent and murderous attack upon the cell nearest maturity, and the inmate of which was dragged out dead about midday. An hour afterwards the sixth left its cell strong and healthy. On September 1st (or the fourteenth day) the seventh and eighth made their appearance, and, taking all

things into consideration, I have to congratulate you on your success."

So far, then, this is the result of my latest experiment, and it only tends to confirm the opinions I had previously formed, and which have been already expressed, and now unhesitatingly state my opinion that the maximum time occupied in hatching a queen is fourteen days.—A STEWARTON APIARIAN.

OUR LETTER BOX.

EXCHANGÉ (A. Johnston).—We insert in a special column exchanges desired. If you send twelve postage stamps, and state what you wish, the statement will be inserted in that column.

DORKING COCK'S COMB DISCOLOURED (Dorking).—It is sometimes indicative of failing condition. Sometimes at this season of the year it is caused by the sharp morning frosts, which begin about this time. At other times it springs from eating improper food, or not digesting that which is eaten. In either case your first remedy is to give a tablespoonful of castor oil, follow it with Baily's pills, feed principally on ground oats, and give no whole corn for a time. Dorkings in confinement require more watching than any other breed, and it is beneficial, when this appearance of comb is seen, to give a couple of pills of camphor, each the size of a garden pea.

LEGHORN AND JERSEY FOWLS (M. H.).—We do not know them. People take strange liberties in naming fowls.

COCHIN-CHINA'S FEATHERS PROJECTING (Buff).—In your young cocks you are plagued with twisted wings. They will not come right in moulting. We have tried various experiments, but have never succeeded, and it is, unfortunately, hereditary. As it is an eyesore, you can improve the appearance of the birds (when the new flight feathers are hard) by cutting them off halfway up, and tying them under the rest of the wing. We have two otherwise fine birds that are so disfigured, and are half disposed to pinion them as we do wild fowls. They cannot fly if they will, and they never try to; we think they would not miss that which in their case is mis-called the flight. We have some confined in a large space, separated from a kitchen garden by a rubble wall between 3 and 4 feet high. The goodly Cochins sometimes look up at the luxuriant green food so nearly within reach, and at last make an effort to get over; it ends in a mighty fly that raises them 18 inches from the ground, a vigorous scramble that finds in their reaching the ground breathless and panting for a quarter of an hour. Your birds should be clean moulted by the first week in November. Soft food is always best, and it is cheaper to give ground than whole corn.

CROSS-BREEDING WITH LIGHT BRAHMAS (Jury Coc).—Of the two varieties you name we should advise you to cross with White Dorkings if size is among your desiderata. If you cross with the Game we advise the White in preference to Piles, only on account of colour.

BRAHMA POOTRA'S FOOT SWOLLEN (Anelia S.).—There may have been a little inflammation in the foot, and the bleeding will do it good. In some cases Brahma cocks affect the dainty style of walking, and it is a bad symptom, often ending in being crippled for life. We advise you to poultice it twice and then bind it up. Shut him up somewhere where he can have nothing hard to tread upon until the foot is quite healed, and where there is no perch. If he is only eighteen months old you should be able to depend upon him for this year. If he is older he will hardly recover to be of much use. If the strange gait arose from the inflammation or injury, he will recover. If it is a sort of "string-halt," we should fear its gaining the other leg. As soon as his foot is well let him return to his ordinary life and to his perch.

DARK BRAHMA POOTRAS (N. S.).—L. Wright, Esq., Kingsdown, Bristol, can give you the information.

MIDDLETON SHOW.—Mr. F. Steel informs us, that at this Exhibition he won the cup for the best pen of Game Bantams.

BREEDING TRUMPETER PIGEONS, &c. (A. Z.).—Put a young Black hen, bred from a pair of Blacks, to a dark Mottled cock, and the produce will most probably be a good number of very dark Mottled birds. If you have no Mottled bird, put a White bird to it, but your chance of breeding dark birds will be of course less. Let the Black bird be the youngest. Of all things make out the antecedents of your stock, and know how they were bred, and whether there is good Mottled blood in them. In breeding Jacobins it is best to keep the colours clear of each other.

PARROT DULL AND SLEEPY (H. T.).—Continue to give your Parrot the usual food to which it has been accustomed, except the rice, which withdraw. Give it boiled Indian corn, and add a little canary seed with the hempseed, also mix a good sprinkling of cayenne pepper with the soaked bread. Parrots are fond of fruit and nuts, but too much fruit must not be given, as it is likely to cause too great a looseness. Keep the bird warm and free from draughts, the moulting, no doubt, is the cause of its being poorly.

HIVE DESERTED (T. T.).—We should fancy that the colony had succumbed to a buccardering attack from robber bees, probably after having lost its queen. It is, however, possible that it may have perished from starvation, and we should therefore counsel an immediate extermination of all your other stocks, with the view of ascertaining and supplying any deficiency that may exist in their stores before the approach of winter.

MILK FOR RABBITS (Antony).—Rabbits are fond of milk, milk and water, or water alone, and ought to have some two or three times a week, not much, but about three or four tablespoonfuls for a full-grown Rabbit. In summer, when all green food is dried up, or at best contains not much moisture, they require more liquid, and a few pens soaked in water about twelve hours form no bad substitute for green food for a breakfast once a week; and if a little clean water be added to the peas it will be better for them than drinking the water the peas have been soaked in all night.

COVER FOR HUTCH (Idem).—Tarpaulin (cheap) may be had at any marine store-keeper's; but for a covering for roofs, &c., the felt at 8d. per yard is as cheap and better, especially when covered with gas tar and

fine sand sprinkled upon it before the tar is dry. It will then last for years.

FOOD FOR RABBITS (Idem).—Half a pint of dry food, as oats, bran, &c., with sweet hay and oat straw for a bed, and to eat if they choose; also a little green food, or Swedes and carrots, will be sufficient for a day's food for any ordinary Rabbit. You will soon find what they require and will eat. All Rabbits are not the same as regards the amount of food eaten.

AGE FOR BREEDING (Idem).—If you wish for large, strong Rabbits, nine months will be soon enough for them to pair, and do not let them produce more than four litters in twelve months.

FUR OF ANGORAS MATTED (Idem).—For the hair to be matted in the Angora is a proof they are of the true kind, as length and fineness of hair are always to be desired in this variety. When the hair is matted it can be removed with an iron comb and scissors, being careful when doing so to cause as little pain as possible. The new hair will soon grow again, even if the fur has been cut bare to the skin.

METEOROLOGICAL OBSERVATIONS

In the Suburbs of London for the week ending October 11th.

Table with columns: DATE, BAROMETER (Max, Min), THERMOMETER (Air: Max, Min; Earth: 1 ft, 2 ft), Wind, Rain. Rows include Wed, Thurs, Fri, Sat, Sun, Mon, Tues, and Mean.

- 5.—Foggy, cold wind; densely overcast; densely clouded.
6.—Densely overcast; overcast, fine; clear.
7.—Cloudy but fine; fine, overcast; densely overcast.
8.—Rain; cloudy, very damp; clear and fine.
9.—Very fine; cloudy; showery at night.
10.—Very fine; fine but cloudy; clear and frosty.
11.—Sharp frost; very fine; clear and frosty.

COVENT GARDEN MARKET.—OCTOBER 12.

THERE is no improvement in the trade, but owing to the falling-off in the supply, the price of Peaches and Nectarines is much higher. Peas principally consist of Marie Louise, Gansel's Bergamot, Duchesse d'Angoulême, and Louise Bonne, but the supply far exceeds the demand. Good samples of Tibston, Cox's Orange, and Blenheim Orange Pippins are now being sent into the market.

FRUIT.

Table listing prices for various fruits like Apples, Apricots, Chestnuts, Cherries, Currants, Figs, Filberts, Gooseberries, Grapes, Lemons, Melons, Mulberries, Nectarines, Oranges, Peaches, Peas, Pine Apples, Plums, Quinces, Raspberries, Strawberries, Walnuts.

VEGETABLES.

Table listing prices for various vegetables like Artichokes, Asparagus, Beans, Broad, Beet, Broccoli, Brussels Sprouts, Cabbage, Capsicums, Carrots, Cauliflower, Celery, Celeriacs, Cucumbers, Endive, Fennel, Garlic, Herbs, Horseradish, Leeks, Lettuce, Mushrooms, Mustard & Cress, Onions, Parsley, Parsnips, Peas, Potatoes, Kidney, Radishes, Rhubarb, Savoys, Sen-kale, Shallots, Spinach, Tomatoes, Turnips, Vegetable Marrows.

POULTRY MARKET.—OCTOBER 12.

WE have little to note. There is a fair supply and small demand.

Table listing prices for various poultry types: Large Fowls, Smaller ditto, Chickens, Ducks, Geese, Pheasants, Pigeons, Rabbits, Wild ditto, Hares, Partridges, Grouse.

WEEKLY CALENDAR.

Day of Month		Day of Week.	OCTOBER 20—25, 1870.			Average Tempera- ture near London.			Rain in last 43 years.	Sun Rises.		Sun Sets.		Moon Rises.		Moon Sets.		Moon's Age.	Clock after Sun.	Day of Year.
			Day.	Night.	Mean.	Days.	m.	h.	m.	h.	m.	h.	m.	h.	m.	h.	Days.	m.	s.	
20	Th		59.0	59.2	49.1	30	32	af 6	56	af 4	29	af 0	34	af 3	25	15	8	293		
21	F	Length of night 13h. 36m.	58.4	39.5	49.0	18	31	6	54	4	46	1	4	4	26	15	17	294		
22	S		58.9	42.4	5.6	23	36	6	52	4	9	3	27	4	27	15	26	295		
23	SUN	19 SUNDAY AFTER TRINITY.	58.2	33.8	49.0	23	38	6	50	4	31	4	48	4	28	15	35	296		
24	M		56.3	39.6	47.9	20	40	6	47	4	58	4	13	5	29	15	42	297		
25	Tu	Twilight ends 6h. 40m. P.M.	55.9	38.5	47.2	21	42	6	45	4	25	7	39	5	1	15	49	298		
26	W		55.6	38.5	46.1	18	44	6	43	4	53	8	10	6	2	15	55	299		

From observations taken near London during the last forty-three years, the average day temperature of the week is 57.5°, and its night temperature 33.6°. The greatest heat was 69°, on the 22nd, 1863; and the lowest cold 17°, on the 23rd, 1859. The greatest fall of rain was 0.96 inch.

FERN CASES.



EVERYONE desires to gratify his or her taste for plants, and in their cultivation finds employment, instruction, and health. Incalculable as are the benefits of the soil and vegetation to man, all cannot engage in the extensive culture of plants, but all may derive enjoyment from an individual plant. In the green of Nature the eye finds repose. To have a green thing with life is a joy to eye and mind. White, blue, and red dazzle,

but fail to relieve. All colours we may imitate, but we fail to produce the live green hues of Nature. No colour is so pleasing. These ideas may not find an echo in the country or garden, but what is that we hear from the town? In the sumptuous palace in the square, and through all the villas, terraces, roads, streets, and lanes, down to the dark and gloomy court and alley from which the sun's life-giving rays have long been shut out—is there no cry there? I trow there is, and it is one that calls for the matchless living green of plants. All the paintings in the world cannot satisfy the eye like the living flowers with their many colours and green ground in beautiful relief. Man may keep the plant in health by affording it soil suited for its roots to spread in, and to give support to the leaves and stems: he can water it, keep it from suffering the injurious effects of an atmosphere which is too hot, too cold, too dry, or too moist, and yet he may not go beyond. It is of this that I wish to say something, knowing, as I do, from an apprenticeship served to growing plants in the midst of smoke, dust, and din, the estimation in which they are held by dwellers in towns. In every house and in every place there are those with a love for plants, be they master, mistress, son, daughter, man or maidservant. I might go further, and say what there is where no plant nor flower ever comes, but I shall draw a veil over it.

We know that dwellings are at the best not good places to grow plants in; the atmosphere is too dry, there are dust, obnoxious vapours, currents of air, and the temperature is not always what it should be. Then some dwellings have no windows with south, east, or west aspects, all look to the cold bleak north. Sometimes, owing to surrounding buildings, little or no sun shines on the houses of those fond of plants. Besides this, there are positions where it is impracticable to grow any but a certain class of plants; I allude to cold rooms, staircases, and landings. Happily we have plants suited to every position. Flowering plants require light, indeed sun, but there are also plants which in the elegance of their forms and the beauty of their foliage amply compensate for the loss of flowers. Of all plants for rooms Ferns are the most suitable. Not that they endure better than flowering plants a dry, dusty atmosphere uneven in temperature—quite the reverse; but they may be cultivated in a way that would be destructive to plants that require sun and a genial atmosphere for their proper development and flowering. Ferns, as we all know, delight in a moist soil and atmosphere, with partial

shade. Of the latter they have enough in rooms, often too much, and the former we have to provide. The only method in which we can give them moisture is by covering them with glass. This is done in a variety of ways, or rather with a great variety of forms in the material used; the form is a matter of little consequence, though appearance is of consequence in rooms where there is any pretence to elegance in the furniture. Individual taste differs considerably, and so do Fern cases, so that all can be gratified.

The requisites of a Fern case are—1st, The case should be deep enough to allow of a proper thickness of soil, which in the smallest ought not to be less than 3 inches, nor in any need it exceed 6 inches. 2nd, In addition to depth for soil there ought to be room for drainage, or an open space beneath the soil. The tray, then, should have a bottom of zinc pierced with holes to allow of water running through, and a space of not less than an inch between that and the bottom proper, which, of course, should be water-tight. It is desirable that this receptacle of drainage water should have an outlet, but secured with a screw-plug, so that it can have the water run off at will. 3rd, The case should have a shade of glass closely fitting into the tray or outside it, and sufficiently high for the development of the plant's leaves or fronds. A height of 18 inches is sufficient, and it ought not to be less than 13 inches. It should be made so as to lift off entire, which is best for small cases, and there ought to be holes in the top. One will suffice for, say, a small case of a foot in diameter: for one 18 inches in diameter three are not too many. The holes need not be more than half an inch wide. If the glass top be fixed, then one or, better, both ends should be contrived for opening, being hinged, and made tight-fitting. At the top there should be a sort of brass network its entire length, and about an inch wide. The above is all that I consider is required for the cultivation of the plants. The design may vary according to taste, and yet it must not be carried out at the expense of diminishing the glass—light is required on all sides.

In preparing the tray for the reception of the plants we put in the loose perforated bottom which is to form the upper part of the cavity for superfluous water, and, to keep the perforations free, put on it about an inch of loose material. Gravel or stones, between the sizes of peas and hazel nuts, or larger, will do well, but are too heavy. Cinders answer well after being washed, cocoa-nut fibre is also suitable: but nothing is equal to pieces of charcoal, the smallest size being as large as peas, and the largest of the size of a cob nut. This material having been put on to the depth of three-quarters of an inch or an inch, we are ready for the soil. The soil most suitable is sandy brown fibrous peat two parts, one part fibrous yellow loam, one part silver sand, and one part sandstone of the same size as the charcoal, but with the finer particles not sifted out, but mixed with the soil. These ingredients having been well mixed, chopped, and made small, but not sifted, put them in the tray, raising it slightly in the centre, but not very much; 1 inch rise in 6 is ample. In case the above compost cannot be procured, one almost as suitable is made of old cocoa-nut refuse, with the addition of a

fourth of loam, and a like proportion of silver sand. Cocoa-nut fibre refuse is sometimes employed alone. It answers very well, only some Ferns grow weakly where there is a deficiency of siliceous matter. The soil should be pressed rather firm, and when put in ought to be in such a state as regards moisture that it does not clog, and to keep it from doing so it will need to be only moderately moist.

The planting must be left to the operator; he or she will place the tallest-growing in the centre, and the dwarf at the sides. Avoid overcrowding, leaving room for all to grow, and avoid deep planting, merely covering the roots. Water well at planting, so as to settle the soil about the roots and to make all firm.

With respect to the after-treatment, the shade, of course, must be put on, or the doors closed; then place the case near a window, but not too close—it ought not to be nearer than from 18 inches to 2 feet—and every morning between eight and nine o'clock look at the case, and if the glass is wet and drops are likely to run down to the tray, leave the doors open about half an inch for an hour or so, then wipe the glass dry with a towel, taking care not to injure the fronds, and shut the openings. If, however, the fronds are wet with the condensed moisture of the previous night, leave a little opening until the moisture is dissipated, and then close the case. This, however, will seldom be required, as the glass may be wiped dry, and a little air in the early part of the day will be all that is necessary. If there are no doors, then admit a little air, if necessary, by tilting the glass a little. This may seem a tedious process, yet it may be dispensed with, and the plants will still grow tolerably well; but the growths will perish of that brownness that invariably manifests itself in a badly-ventilated structure, and where constant moisture from condensation settles and remains on the fronds. I have known instances of cases not being opened, nor even watered, for three months. I mention this not for imitation, but as exhibiting the great endurance of this tribe of plants. So long as the glass is only covered with a sort of dew, which does not run down the sides or fall in drops on the plants, there is no need of air. However, I strongly advise wiping the glass dry at least once a day. It gives a change of air if it does nothing else, and keeps the atmosphere from becoming stagnant. The same object as wiping the glass dry will be effected if the opening be left open sufficiently long, but this would dry the fronds too much. The case should be closed at night.

Water should be given as required, so as to keep the soil moist, which it ought always to be, without, however, being very wet. Less water will be required in winter, when the plants are at comparative rest, and the evaporation less than it is in summer, when the plants are growing freely. Every spring the surface soil should be removed as far as can be done without injury to the roots, and a top-dressing given of the compost I have recommended. The water should be run off after each watering.

All dead fronds should be picked off as they appear, and a strict look-out kept for insects. The most troublesome are thrips and scale. The former may be removed with a wet sponge, but for the latter the best remedy is to pick them off with a knife before they become brown and hard. If thrips is very troublesome, it would be well to remove the Fern case to an outbuilding and fill it with tobacco smoke, repeating it two or three times until the insect is extirpated. Green aphids sometimes appear. It is best destroyed by fumigation with tobacco.

Another point will need attention—that is, the shading of the glass from sun, if it strike upon the case, for a few hours during the hottest part of the day. This object is best effected by a piece of muslin placed on the window side of the glass. From September to April shade will not be necessary. If the Ferns grow all to the side next the window, turn the other side to the light, and this ought to be done at least once every week. Of course, if the light be equal from all points, this will not be necessary.

I purpose to conclude with three lists—one of hardy Ferns, suitable for rooms without fires, landings, or other cold situations; one of greenhouse Ferns, or those which may be grown in rooms from which frost is always excluded; and one of stove Ferns, or those suitable for a room never lower in temperature than 50°.

For a Cold Room—*Asplenium Trichomanes*, *A. Trichomanes multifidum*, *A. Adiantum-nigrum*, *Blechnum Spicant* and its varieties *ramosum* and *cristatum*, *Lastrea Filix-mas crispata*, *L. Filix-mas Schofieldii*, *Polypodium vulgare*, and vars. *cristatum*, *bifidum*, *omni-laceraum*, and *cambricum*; *Scolopendrium*

vulgare, and vars. *polyschides*, *ramosum*, *subcornutum*, *multiforme*, *proliferum*, and *foecundum*, and *Lomaria alpina*. The above are all evergreen, and lack the grace and elegant fronds of some of the deciduous kinds, which I must not omit:—*Athyrium Filix-fœmina depauperatum*, *Cystopteris fragilis* and var. *interrupta*, with *C. Dickiana*, are very pretty.

For a Room with Fire—**Adiantum capillus-Veneris*, **Acrophorus hispidus*, *Anemidietyon Phyllitidis*, *Adiantum æthiopicum*, *A. cædulosum*, **Asplenium flabelliformis*, *A. monanthemum*, *Blechnum cognatum* (australe), *Davallia canariensis*, *D. decora*, *Goniophlebium loricum*, *Lastrea acuminata*, *L. glabella*, *Lomaria Patersoni*, **Niphobolus lingua*, **N. pertusus*, *Nephrolepis tuberosa*, *N. pectinata*, *Onychium japonicum*, *Platyloma rotundifolia*, **Pleopeltis stigmatica*, *P. pustulata*, *Polystichum triangulum*, *Pteris serrulata cristata*, *Woodwardia caudata*, and *W. aspera*. Of *Lycopods* or *Selaginellas*, *denticulata*, *nucinata*, *densa*, *ohutua*, and *Willdenovi*.

For a Warm Room.—*Æmisia adiantifolia*, *Adiantum cuneatum*, *A. formosum*, *Asplenium dimorphum*, *A. mexicanum*, *Campylopusium angustifolium*, **C. cæspitosum*, *Diplazium ramicans*, *Davallia elegans*, **Goniophlebium vacciniifolium*, **G. piloselloides*, *G. latum*, *Goniopteris gracilis*, *Hemionitis cordifolia*, **Pleopeltis lycopodioides*, *P. terminalis*, and *Pteris crenata*. Of *Selaginellas*, *africans*, *jamaicensis*, *umbrosa*, *flabellata*, and *dichrous*.

Those marked with an asterisk are very suitable for suspended baskets in the Fern case, and for covering rockwork.

The neatest baskets are, perhaps, the half of a cocoa-nut shell suspended by neat brass chains. Rockwork may be indulged in in a Fern case, and I have seen some very pretty devices of that sort; waterfalls, dropping wells, and even a fountain having a pretty effect when done in moderation. It is possible to overdo them even in a Fern case.—G. ABBEY.

GROUND LEVELLING AND PRACTICAL GARDEN PLOTTING.—No. I.

THESE are a number of works on the designing of flower gardens in circulation at the present time, expounding both the theory and practice of the art, many of them admirable in themselves, but it has never been the good fortune of the writer of these notes to meet with one which literally "begins at the beginning." They either assume that the reader is already acquainted with the theory and practice of geometrical problems, or they are expressed in such elaborate language that the unlettered thousand can scarcely comprehend them. My object is to supply this deficiency. The subject is not here treated as a mathematical one, but as one of a purely practical character. I have avoided technical terms as much as possible, endeavouring by simple language to make myself clearly understood by those for whom this is written. I know from personal experience as well as observation, it is the opinion of many young men that it is necessary to have mastered the whole of the problems of geometry previously to attempting to draw a plan to suit a certain piece of ground, and that to transfer to the ground an intricate design already executed on paper is a task almost as difficult. To be a practical gardener it is not necessary to be a garden artist. Nevertheless, in this progressive age, when education is daily becoming more general, it is essential that every man, be his profession what it may, should understand the rudiments of the theory of that profession. It is at least necessary that every gardener who wishes to attain a good position in his profession should be able to design a plan upon paper to suit such ground as he may have under his care, and also to transfer that design to the ground.

It is not my intention to discuss the merits or demerits of the different styles of flower gardening, but it is obvious that before commencing the laying out of a piece of ground, the gardener must have some definite design, geometrical or otherwise.

My notes being elementary in character, and chiefly designed as an exercise for young men whose only time for improvement is after their day's work is accomplished, it will be found that only a few geometrical problems are introduced, being such as are absolutely necessary for the formation of more intricate designs. These, however, will be soon overcome after a few hours' careful study; but two things are necessary—care and perseverance. The pupil must be careful in referring to or copying the designs, to observe accurately the numbering and lettering of the figures, and he is advised not to be satisfied with mere copying, but from the first to practise the drawing of designs other than those here given, however imperfect his first

attempt may be. He will find that by these means he will be able in a very short time to employ his leisure hours in either copying or designing a plan. He may then take the garden line, pegs, &c., to any spare piece of ground he may have in the garden, and execute the design described.

The greater number of the designs introduced are original, others have been suggested by designs laid out, and a few taken from works already in circulation, but so altered and simplified as to be altogether unlike the original, except in character. In introducing the illustrations, the object will be to arrange them that they may follow evenly from one to another, from the simple square or triangle to the more intricate designs, the manner of transferring them to the ground being explained in the most simple language possible. The pupil is urged to pay strict attention to the geometrical problems introduced—how to bisect a given line, erect a square, form an equilateral triangle, &c., as they will be of infinite use to him in converting a design already executed to a piece of ground of a different shape, and also for their adaptation in the more advanced illustrations. By the time the pupil can draw on paper and execute the designs here given, he will have accomplished much towards the attainment of a more general knowledge.

Having determined upon the site for a flower garden, and the style in which it is to be laid out, the first thing to be attended to is to see that the land is well drained.

LEVELLING.

If the ground presents an uneven surface, or is formed of a sloping bank, either inconveniently steep or presenting an irregular surface, it will be necessary to level it, which may be done in the following manner:—Take a stout peg and drive it into the ground, as *a*, *fig. 1*; take a level—either such as is used by bricklayers, as in *fig. 1*, or a parallel straight-edge containing a spirit tube, commonly known as a spirit level—drive in as many pegs as are required, as *b*, to the same level as the first peg *a*. The level line, *c, c*, is the line required; the ground line, *d*, is the uneven surface of the ground, which requires filling up to the level at peg *b*. As soon as the pegs are in, level the ground with a spade, keeping the earth fall up to the top of the pegs, tread it firmly all over, rake it carefully, and roll it well.

If the ground chosen should be sloping, as *b*, *fig. 2*, two depths must be determined upon, one at the highest, and one at the lowest point. Place a boring-rod at each of these points,

as at points 1 and 3, place another in any point between the two, as the intermediate boring-rod 2. By looking over the top of rod 1 the person holding the intermediate rod can be directed to lower or raise it as occasion may require, until it is brought to the proper level, as rod 2. Rod 1 is supposed to be a little raised by placing some earth under it, for the purpose of getting it to the proper level, *a, a*—that is, the level determined upon. Rod 2 is elevated until the top edge forms a direct line with rods 1 and 3. Rod 3 is placed on the natural ground. The cross piece of rod 3 should be 1 inch broader and higher than the others—that is to say, if rods 1 and 2 are 4 feet high, rod 3 must be 4 feet 1 inch, but a line must be drawn exactly at 4 feet, and the top inch painted black. On looking over rod 1 the black line on rod 3 can be seen more distinctly than the top edge of the rod would be, and intermediate rod 2 can be placed more correctly in a line with the top of rod 3—that is, the under edge of the black, than by looking over the tops of the three rods.

The boring-rod is composed of a thin piece of board about

4 inches wide, half an inch thick, and about 4 feet in length. The head is a similar piece of board placed crossways, but only about 18 inches in length. The upper and under edges of the board must be perfectly straight, and at right angles with the body.

The surface of the ground should be perfectly smooth before commencing to trace the design on it. If it is to be turfed and the beds formed, lay all the lines. Insert pegs along the lines and in the angles of the beds, so as to form guides by which to lay the turf. After the pegs are put in take up the lines and lay the turf, allowing the edge to go 2 inches beyond the line required, so as to have sufficient firm ground to dress and form the edges of the beds. As soon as the turf is all laid roll it well, stretch the lines in the proper places as directed, and edge the beds.

If the site is intended for embroidery or any complicated design, it is necessary when digging the ground to pick out all the stones, as in cutting the edge against which to lay the Box a small stone might cause trouble, by preventing the spade from going into the ground or by breaking the edge.

When the ground is properly level and smooth on the surface, proceed to trace the plan upon it; as each bed is traced insert pegs 7 or 8 inches apart. When the design is all traced and pegged out, lay lines along the pegs, and proceed to cut the edge against which to lay the Box. The edge must be cut perpendicularly, as at *s*, *fig. 3*.

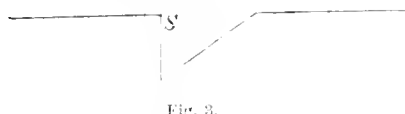

Fig. 3.

Lines of Box embroidery vary in thickness. With regard to

the thickness, the outside lines should first be planted, and then the intermediate space filled in afterwards. As soon as all the box is planted the whole should be clipped to an equal height, and flat at the top, irrespective of thickness. The soil must be carefully taken away from the walks

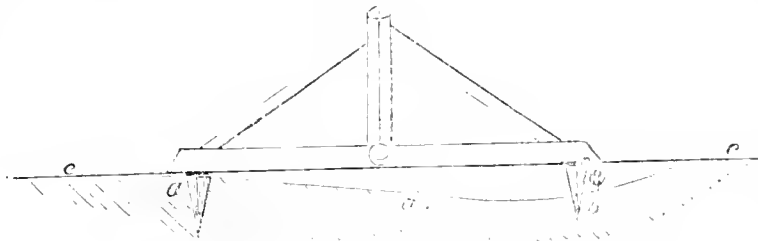

Fig. 1.

to the depth of 8 or 9 inches; place about 2 inches of cinder ashes over the bottom to prevent the worms from coming through the gravel, place 5 inches of brickbats or any rough rubbish over the cinder ashes, and then 2 inches of good gravel, keeping the finest on the top. When the gravel is all on, roll it well. If the design is too complicated to admit

the roller, a turf-beater will answer.

Should coloured materials be required to give effect in the winter months, the soil must be taken away the same as from the walk, but not to the same depth; 4 or 5 in.

will be sufficient—2 inches of cinder ashes, and 2 inches of gravel—then lay the coloured material on the top, such as Derbyshire spar, coal, red brick ends, &c.—*M. O'BRIEN, Gardener to E. Leeming, Esq., Spring Grove, Richmond.*

HORTICULTURAL FALLACIES.

We hear of a deal of red tape and routine when the doings of our rulers are discussed; how few can shake off the influence of habit and custom in their own affairs. People come here and admire my house, say how light yet strong they are, seem surprised at the cost not having been more, discuss everything peculiar in their construction, and finish by inquiring the name of the builder. The next thing I hear is that an application has been made for a plan and estimate for a house or row of houses on the oldest and most expensive plan on which a glass

shed was ever erected—heavy rafters, moveable lights, high back walls, arches of brickwork for Vine roots to pass into, sunk borders, &c. What possible advantage rafters and moveable lights confer I am quite at a loss to conceive. The disadvantages are very obvious, one would think. The roof is heavier and darker, and much more expensive. Moveable lights mean friction, numerous spaces for moisture to act on wood and paint, and the impossibility of ventilating in rainy weather without letting in the wet, and very often they mean a good amount of drip. How anyone who has seen ridge ventilation, and light grooved sashbars all of a size, forming a fixed and impenetrable roof free from drip in all weathers, taking about half the paint that a roof with heavy rafters requires, costing less, and lasting longer, can go back to the old and stupid plan of building I can never imagine. Want of thought and routine must be the only explanation.

Then, again, how often do we see 2 or 3 feet of soil removed to make a Vine border. Can anyone doubt that a Vine border would not in all cases be better, warmer, drier, if raised above the surface? Again, if the situation be naturally dry or well drained, what possible advantage can there be in laying a bed of concrete under a Vine border, or masses of broken stone or bricks? In low situations, where the land is cold, heavy, and wet, one can understand the necessity, though we must feel surprised at such a situation having been chosen for a garden in the first instance; but in dry and favourable situations what end is sought by such preparation? Has it been found that in farming, for instance, a hard and impenetrable pan under a cultivated soil is an advantage? Or is it thought an advantage to cut off the natural effects of capillary attraction in dry weather? I think there can be no doubt that the Vine is the most easy fruit tree in the world to grow, that it will endure worse and more unnatural treatment than any other tree, or, I am sure, a bunch of decent Grapes would be a much rarer sight, for no plant appears to me so badly used. Instead of copying Nature in its cultivation, every unnatural and expensive plan appears to have been hit upon to increase the risk of failure? When will people throw red tape and routine aside, and think for themselves?—J. R. PEARSON, *Chilwell*.

BEDDING GERANIUMS.

(Continued from page 261.)

NEXT to the Golden Tricolors, and not far behind them in beauty, come the Silver Tricolors. Of these I have but three varieties—Mabel Morris, Princess Beatrice, and Empress Eugénie. They are all three lovely as pot plants, but have done next to nothing in the borders owing to the excessive drought. As this has been my first year's trial of them in the open air, I can say no more than that I hope to be better acquainted with them in the future.

More striking, perhaps, and very beautiful are the Bronze Zonals or Bicolors. Of these I have the following—Goldfinch, Eclipse, Mrs. Bass, Madeleine Schiller, Egyptian Queen, Perilla, Compactum, Beauty of Oulton, Black Prince, Southern Belle, Ebor, Prima Donna, Sybil, and several seedlings not differing much from the latter. Of these, Egyptian Queen has carried off the palm for richness of foliage; its growth, also, has been such as to indicate an improved vigour of constitution. Older plants have grown better than cuttings of last year, and when pegged down have covered the ground very nicely. Next comes Black Prince, which has beaten every other of my Bronzes in vigour and habit, although it has yielded the palm for warmth of foliage to Egyptian Queen. I consider this Geranium a great acquisition, having tried it under very different circumstances, as well under partial shade as in the full blaze of the sun. I can imagine it might grow somewhat rampantly in moister seasons, but by taking off cuttings from time to time during the summer, it can be kept easily within bounds, and it yields them very freely. Another advantage of this plant is the character of its bloom—fine trusses of a rich crimson scarlet on sturdy stems thrown up just above the foliage; nor do the leaves burn and become unsightly as with many others of this class. This is a great fault of Egyptian Queen. Black Prince will also bear pegging down very well.

Of the rest, Sybil is an exquisite Geranium, but I planted it too near some *Echeveria metallica*, which, being a gross feeder, no doubt robbed Sybil of some of its fair share of nutriment. Hence it made but little growth, and remains still on its trial. Beauty of Oulton has been much admired, and has stood the season well. It is a healthy vigorous plant, and will maintain

its ground here for some time, I think, but it comes far below Black Prince in many points of excellence. All the others have disappointed me in various ways, notably Southern Belle and Prima Donna, from which I expected great things, but they were placed in the driest of the dry, and therefore had no fair chance against the others; in fact, one plant of Southern Belle fairly died from want of moisture.

Amongst the elder varieties of this class Eclipse and Mrs. Bass have a charm of their own which makes me retain them. Their paler foliage contrasts more strikingly and looks more brilliant at a distance than some of the finer Bronzes, but they have great faults which detract from their beauty, particularly in the way the leaves fade away and shrivel to a dirty whitish-brown shade: hence their dismissal from the garden is only a question of time.

I defer some remarks I have to make upon the Zonal and Nosegay section to a future occasion.—B. & W.

(To be continued.)

PEACHES AND NECTARINES.

THE season is now (October 11th) over. My last dish of Nectarines was Rivers's Victoria, a large and invaluable sort, and my last dishes of Peaches were the Princess of Wales, Walburton Admirable, and Lord Palmerston, all fine late sorts. There could not have been a better season than the past. The fruits were abundant and of great size. All the trees, except Walburton Admirable, bore great crops. I have no Peaches and Nectarines under glass. All were grown on 6 or 7-foot-high brick walls on east, west, and south aspects. The gardens are nearly as open to violent winds as the Eddystone Lighthouse, Stonehenge, or the Bill of Portland. "D." of Deal, saw the fruits in a young state on July 26th; I wish he had seen them at maturity.

The following are the Peaches grown here:—Early York, Early Victoria, Dr. Hogg, Early Ascot, Early Alfred, Marquis of Downshire, Grosse Mignonne, Royal George, Noblesse, Violette Hâive, B-legarde, Barrington, Nectarine Peach, Prince of Wales, Princess of Wales, Walburton Admirable, and Lord Palmerston. Lady Palmerston, Mr. Radelyffe, Magdala, Golden Frogmore, and Early Rivers were not in crop this year. The old sorts are well known, and, as midseason Peaches, will not be easily beaten.

Dr. Hogg is a splendid early Peach. Early Alfred is a great cropper, early, and good. Nectarine Peach is a jewel; it is as smooth as a Nectarine, of fine form, colour, and flavour; of the late series it is the best of all. Prince of Wales, Princess of Wales, and Lord Palmerston are grand late Peaches. Princess of Wales and Lord Palmerston are here the largest of all the Peaches; both have creamy cheeks with bluish suffusion; they are very late, and very valuable. The above new Peaches were raised by Mr. Rivers. The blossoms of Princess of Wales and Lord Palmerston are the finest of all the sorts here. Early Ascot is a Peach of great beauty, and of first-rate formation and flavour. It is as smooth as a Nectarine. Marquis of Downshire bore (second year) a fine crop. It is later than the former. They are both plants of excellent habit, and do Mr. Sandish great credit. Of these novelties, for a small selection, I name Dr. Hogg, Nectarine Peach, Prince of Wales, Lord Palmerston, and Early Ascot.

If the reader will recollect that Walburton Admirable is a shy bearer, it is impossible for one to burn his fingers with any of the others, old or new; they are hardy, good growers, great bearers, and altogether excellent. There is no Peach here superior to the Royal George for habit. The leaves and triple buds are so near together, that if a man cannot get a crop off it, the sooner he gives up Peach-growing altogether the better. The Prince of Wales, Early Ascot, and Marquis of Downshire have the same good attributes. The Noblesse and Nectarine Peach have been the best in flavour and quality of flesh. Noblesse has but one fault—it is shy of producing leaves.

The Nectarines here are Newington (Rough Roman), Elruge, Violette Hâive, White Nectarine, Murray, and Balgowan. These are all well known, and are excellent. Newington is a clingstone, and one of the richest when ripened to shrivelling. The following are new:—Rivers's White, a week or more earlier than White Nectarine; Rivers's Orange, Rivers's Pine Apple, and Rivers's Victoria, the latest of all. The two last-named I specially recommend; they are the finest of all, and very valuable. Now, if the reader cannot please himself out of the above, I fear nobody else can please him. They are all hardy,

great besrers (I see no difference between Elruge and Violette Hâtive, they appear to be the same, or nearly so), and of excellent flavour. Have which your readers will, they cannot burn their fingers. I thank Mr. Rivers and Mr. Standish for raising such noble fruits.

A good successional selection of Nectarines would be Elruge, Rivers's White, Rivers's Orange, Rivers's Picoe Apple, and Rivers's Victoria. The last brings the season to October 11th.

I conclude with a few observations. I prune the trees on the alternate system, as recommended by Mr. Bichaut in his valuable "Peach Pruner." Unless I wish to fill in a vacant space, few of the shoots are more than 6 or 8 inches long. Some are pinched to two and four full-sized leaves. I disbud but little, and pinch to two leaves for spurs. The same shoot will never bear again. It is, therefore, best to prune short, and leave three shoots 4 inches long at shorter distances than leave a shoot 12 or more inches long. If you cannot ripen a shoot 4 inches long, how can you expect to ripen a shoot 12 inches long? If the winter kills, as is often the case, an unripened shoot, you get a bare space without a chance of succession. I rarely have a dead shoot in winter. Long twigs in "misery" are often sent to me by other people. If nurserymen would shorten the twigs of their one-year-trained trees one-third, these would probably produce fruit the first year after removal. They look, of course, more worth the money untouched. I keep my trees root-pruned, and hence I am able to grow more sorts. If the roots are allowed to ramble, you must permit the trees to ramble, or they will gum. The result is in time a large bare space at the base and centre of the trees. I have "expletives," or small trees, some on short stocks and others headed-off into standards, to fill up all interstitial spaces and gaps. These are kept short-pruned, and are removed annually to be root-pruned, in order to keep head and roots good friends. I stop the extensions in August, and the other shoots in June. All my trees are now nearly bare of leaves, are pruned, and are tied with bast to cast-iron nails. The bast should be crossed, so as that the nail may not touch the twig.—W. F. RADCLIFFE.

THE CULTURE OF LILIUM AURATUM.

This is without doubt the most popular of the Lily tribe, and bids fair to become the most popular of plants, now that its price has placed it within the reach of the humblest owner of a greenhouse. Numerous distinct and beautiful varieties are in cultivation, and a fair field is open to the hybridist, as a most distinct and lovely variety, said to be a cross between *L. auratum* and *lancifolium*, was exhibited at South Kensington lately. As to the varieties of *auratum*, their distinctiveness consists not only in the size, colour, and shape of the flowers, but also in the number of flowers borne on a spike. Some of the varieties have from three to six flowers on a spike, others from thirty to forty. I obtained a number of bulbs of *auratum* of nearly equal size, as imported from Japan, in February, 1867. No notes were made of their growth or flowering in that year, but in the following three seasons the subjoined notes were made. The produce of each bulb was each year reported in a pot by itself.

No. 1.—1868 had 1 spike 16 flowers	No. 3.—1870 had 14 spikes 33 flowers
1869 had 4 " 32 "	No. 4.—1868 had 2 " 13 "
1870 had 6 " 134 "	1869 had 4 " 25 "
No. 2.—1868 had 1 " 25 "	1870 had 9 " 75 "
1869 had 1 " 24 "	No. 5.—1868 had 2 " 9 "
1870 had 2 " 39 "	1869 had 2 " 9 "
No. 3.—1868 had 3 " 9 "	1870 had 2 " 7 "
1869 had 3 " 10 "	

The remaining roots did not succeed well; bulbs were not increased to a large extent, and not more than one or two flowers were borne on a spike. No. 1 had flower-spikes 10 feet in height, and the largest number of flowers on a spike was thirty-five. Some of the varieties do not grow more than from 2 to 3 feet in height, and have the finest individual flowers.

Nearly all the Lily tribe are of easy culture, and *Lilium auratum* is not an exception. October is a good month to repot the bulbs; it is not advisable to dry them off, as is done with Hyacinths, Tulips, and other bulbs. Water ought to be administered sparingly previous to potting, and as soon as the leaves assume a yellow tinge the stalks may be cut over and the bulbs potted. In potting, some cultivators disturb the bulbs as little as possible, merely scratching away the loose soil with a pointed stick, and repotting in a pot a size larger; I consider it best to shake the soil entirely from the roots, separating each bulb, and saving the fresh roots as much as possible. As many as a dozen bulbs are planted in a 13-inch pot, three of

the larger bulbs are placed in the centre, and the remainder round the inside of the rim. I find they succeed well in a compost of three parts of turfy loam and one part of leaf mould and rotted manure, with a portion of silver sand to keep the material open.

If the compost in which the bulbs are potted is somewhat moist, no watering will be required. The pots ought to be plunged in a cold frame, and I do not know of anything better for this purpose than cocoa-nut fibre refuse; and if the pots are completely buried in it, so that there may be at least 4 inches of the fibre over the surface of the soil, there will be no danger of the bulbs being injured by frost. The lights ought to be kept off the frame, except during severe frost and drenching rains. The bulbs will continue to make roots all the winter. The cocoa-nut fibre refuse ought to be removed from the surface of the pots in March, and if the bulbs are doing well roots will be found pushing upwards into it. The plants ought to remain in the cold frame until May, when they can be placed on a hard bottom in a sheltered position out of doors until the flowers begin to open, when they must be removed to the greenhouse or sitting-room. Manure water may be occasionally administered to them, but they will do well without it; of course if they are wanted for exhibition or any other special purpose, extra care must be bestowed upon them. If they have to be removed a distance when in flower, the anthers ought to be wrapped round with tissue paper, in order that the dark brown dust may be prevented from shaking on to the petals, as it sadly disfigures the flowers. I have seen them brought to an exhibition when this precaution has been neglected, and the flowers were entirely spoiled.—J. DOUGLAS.

STOCKS FOR APPLE GRAFTS.

In reference to the inquiry at page 243, and the information kindly given at page 262 by Mr. Scott, we may pursue the subject with profit, I think to its more complete explanation.

We understand the English Paradise to be the Burr Knot and the Nonesuch, both Apple stocks chosen for this purpose. The Crab stocks, Mr. Scott says, are raised from cider pomace—*i. e.*, the seeds washed out of the cider residuum, and are not the true Crab or wild Apple stocks. Doubtless a host of stocks are produced from cider refuse seeds, but are they not called Free stocks as distinguished from Crab stocks in the nomenclature of their class? and is not the Crab or wild Apple cultivated for stocks? If not, we are growing varieties of Apples on other varieties of Apples, just as we do on the Burr Knot and Nonesuch (called English Paradise), and are in the dark how far, if at all, any or each variety of Apple stock affects any other variety of Apple, scion and fruit, grafted upon and produced from its Apple stock of indiscriminate use. Such would not be the case if Crab or wild Apple stocks were used as Crab stocks, as they alone ought to be, and not confounded with Apple stocks: inasmuch we are all duped, as the Apple stocks, the medley of cider refuse seedlings, go by the name of Crab stocks amongst our nurserymen. We can predicate the result, in growth and produce, from the Crab or wild Apple stock (the only veritable stock), and perhaps from the Burr Knot and Nonesuch Apple stocks; but from such a chaotic mass as cider Apple refuse seedlings render, all must be chance and uncertainty throughout—that is, if the stock do—and it does—influence the graft or scion and its fruit for better or for worse. The mischief lies in the sport or variation, apt to show itself in the same fruit on different and haphazard stocks. Do not cider Apple growers cultivate stocks of each reputed cider fruit, on which stocks alone they graft each peculiar cider scion, stock and scion identical, for verity of produce? So I have been told.

The Stibbert stock, too, by Mr. Scott's kindness, we now understand is the Dutch Codlin Apple—Apple on Apple again, subject very likely to uncertainty in truth of produce, inasmuch as Apple stock may affect Apple scion and fruit, as is already suggested.

And I may appropriately ask, If and in what respect the Burr Knot, the Nonesuch, and the Dutch Codlin stocks affect the scions and fruits grown upon them respectively? The answer would indicate what we may anticipate from cider refuse seedling stocks—Apple stocks at a venture.

Here I will digress, and designate the practice of sending out cider Apple seedling stocks for Crab stocks as, if not a cheat, most reprehensible, and demanding attention from the Royal Horticultural Society as likely to spread a mongrel produce over the face of our gardens and orchards.

What the Doucin and French Paradise stocks are is a myth to us. That the Doucin and the French Paradise are distinct stocks is all we can gather, but the species of each stock and in what they differ are still to be described to us. Even Mr. Scott characterises these stocks as a "mélange of sundries"—not a very complimentary reflection upon our neighbours over the Channel, but perhaps not inappropriate to the deserts of the subject before us, and, like too many alien subjects, inaptly adopted for fashion or gain only. Will Mr. Scott, Mr. Rivers, or M. Du Breuil, tell us something about those Doucin and French Paradise stocks?

With Mr. Scott's aid we come to the Pommier de Paradis, a stock in itself, with the merit, at all events, of a candid character, and no duplicity about its identity. Its other merits as a stock are best left to Mr. Scott's own advocacy and experience, able, ample, and reliable alike. The name alone appears to confound the Pommier de Paradis with its ally, or enemy—which, I know not—French Paradise, and would be better changed for its own credit and reputation. In short, call things by their proper names, and let us know what we are doing in our dealings. Honestly and openly say the Burr Knot stock; the Nonesuch stock; the Dutch Collin stock; the Crab (and not Apple), or the English Crab stock; the Caucasian Crab stock, in lieu of Pommier de Paradis; the cider pomace Apple stock; the Doucin stock; the French Paradise stock. Thus we shall have our choice, and the best stocks in time will find their way to the front. As we stand, we are provoked by a maze of fantastical stocks, deceptive to every lover of genuine British pomological produce.—READER.

INFLUENCE OF THE MOON ON RAINFALL.

It is a matter of almost universal belief in the bucolic mind that the moon exerts a very great influence on changes in the weather, and if a particular lunar phase occurs on the Saturday before the harvest, it is accepted as prognosticating a wet season. Men are found saying they have verified the phenomenon for fifty years, and even intelligent farmers accept it as a fundamental fact of meteorology. From an article by Mr. Pengelly, in the *Quarterly Journal of Science*, we extract the following remarks bearing on the subject:—

That the moon is very influential in, or at least closely connected with, all changes of the weather, is a belief at once widely spread and deeply rooted. Our satellite can neither be full, nor new, nor "fill her horns," without, as is popularly believed, causing or indicating some alteration in the state of the weather. If she is caught "lying on her back," or, in other words, if, when she is less than a semicircle, her cusps are pointed upwards so that the straight line joining them is more or less approximately parallel to the horizontal plane, the fact is supposed to be an indication if not the cause of rain. If she submits to be "towed by one star and chased by another,"—that is, if she is between and near two conspicuous stars, so that the three bodies are at least nearly in a straight line, the fishermen expect a storm.

Though meteorologists show no favour to these and many similar beliefs, some of them admit that it is neither unphilosophical nor contrary to fact to regard the moon as a meteorological agent. Thus, Sir John Herschel, from his own observations, regards it as a meteorological fact that the clouds have a tendency to disappear under the full moon, and adds that a slight preponderance in respect of quantity of rain near the new moon over that which falls near the full, would be a natural and necessary consequence of a preponderance of a cloudless sky about the full. M. Arago, who concurs in this opinion, states that the expression "the moon eats the clouds," is common in France among country people, and especially among sailors. The latter philosopher adds that the results obtained from meteorological observations in Germany and in Paris, were that the maximum number of rainy days occurred between the first quarter and full moon, and the minimum between the last quarter and new moon; the ratios being 100:121.4 in Germany, and 100:126 in Paris; but that in the south of France the minimum number of rainy days occurred between the full moon and the last quarter. He concludes with the remark that "the question requires to be examined afresh."

Mr. Pengelly then gives his own carefully made series of rainfall observations, extending over a period of six years, or rather seventy-four complete lunations. From these we find that the greatest amount of rainfall occurred in the second quarter; the greatest number of wet days in the third; while the mean rate

of rain on wet days was greatest in the second quarter. The author summarises these facts as follows:—1, The least average rainfall was in the quarter immediately preceding the new moon, instead of, as Sir J. Herschel supposes, about the full moon. 2, The maximum number of wet days was in the third quarter, and the minimum in the first—thus differing from the results stated by M. Arago to have been obtained in Germany and Paris on the one hand, and the south of France on the other.—(*English Mechanic*.)

COMPARATIVE TRIAL OF PEAS.

With the assistance of a friend, who lived some distance off, to join in the trial, I have grown sixteen varieties. Although in every case but one my crop was larger than his, the relative proportions were remarkably equal. We found, out of the sixteen sorts tested, the Hundredfold stood first without a doubt, and the Imperial Wonder second best; Waterloo Marrows were third in productiveness.

It is but just to add that the general crop of wrinkled Peas suffered very much from blight, which made Fairbeard's Champion of England and Veitch's Perfection show as tenth and fourteenth on our list—much lower than would otherwise have been the case. I have enclosed a list. The first two columns show the number of peas and pods, and the third column the average produce of one plant. The other columns tell the number of days from the date of sowing to the date of first showing above ground, number to the date of ten flowers, and to the date of ten pods of peas fit to gather. Of course there was some irregularity in the time of coming up on account of the peas being sown in different depths of soil. I have arranged them in their order of earliness, and lettered them A to Q for productiveness.

Productiveness.	Name.	No. of Pods.	No. of Peas.	Average of Peas per pod.	Number of days after sowing.		
					up.	in flr.	'bear'g
D	Carter's First Crop.....	8.6	43.0	5.0	16	57	75
I	Daniel O'Rourke.....	9.5	49.7	5.25	18	61	80
M	Tom Thumb.....	9.25	37.7	4.0	17	61	81
N	Macleod's Advancer.....	6.9	37.1	6.5	17	62	82
P	Prizetaker.....	5.0	30.2	6.05	18	65	90
A	Hundredfold.....	8.75	53.7	6.25	19	66	90
K	Champion of England.....	9.7	39.6	4.25	18	67	91
L	Woodford Marrow.....	8.3	38.7	4.7	19	70	94
H	Laxton's Prolifer.....	7.45	44.8	6.0	17	63	92
Q	Early Surprise.....	6.45	28.7	4.5	17	66	92
C	Waterloo Marrow.....	14.45	50.7	3.5	18	70	92
E	No Plus Ultra.....	9.2	46.3	5.0	18	71	92
O	Veitch's Perfection.....	7.8	34.3	4.55	18	66	94
F	Princess Royal.....	9.6	45.8	4.75	18	69	96
B	Imperial Wonder.....	9.5	50.7	5.25	21	69	96
G	British Queen.....	9.65	45.0	4.7	22	73	99

I should be glad if others in different parts of the country would join me in a similar experiment next year.

I also wish to ask advice as to dressing Apple trees affected with American blight. This spring all my trees were detached from the walls and thoroughly anointed with a solution of Gishurst compound, and the walls carefully washed with a mixture prepared according to your directions, but in spite of all this, I never saw any trees so entirely covered as mine were this autumn.—E. G., *Leighton Buzzard*.

FLOWER-BED ARRANGEMENTS.

We are so pleased with your reply to our letter in the *Journal* of September 8th, and the friendly criticisms of Mr. Peach in that of the 22nd of the same month, that we trouble you again. We must thank you and Mr. Peach, through the medium of "our *Journal*," for your criticism; and with the suggestions you each offer, and the re-arrangement we had made on our coloured plan, we hope next year to have the *tout ensemble* perfect. We omitted to say in our last that beds 8, 9, 10, and 11 (see page 186), have a plant of *Humea elegans* in the centre, and 8 and 9 are carpeted with *Viola cornuta*, though the *Geraniums* have grown so vigorously that only a few flowers of the *Viola* are seen peeping above the white foliage. The alterations you suggest relative to clumps 6 and 7 we think would be an improvement, and father says when the summer bedding plants are taken off, before we plant our spring flowers and bulbs, the beds shall be formed according to the suggestions of the Editors.

The design respecting which we now seek your advice, and of

which we enclose a copy, is situated directly opposite our cottage, and only separated from the highway by a low row of palisading. The enclosure containing this flower garden is but small, and the beds but few in number, yet in this spot we concentrate our choicest plants, and at all seasons of the year we try our best to make it a spot of surpassing beauty. There is not a day throughout the year that the beds are unoccupied, for if in the morning we clear them of the summer plants, before evening we furnish them with others that have to remain through the winter, to cheer us with their pretty blooms in the spring, and *vice versa*. The walls of the cottage are mantled with Roses, Clematises, Cotoneasters, &c.

I will now tell you how the beds are planted, and afterwards make a few remarks respecting the properties of the different plants employed for decoration. The beds are planted as follows:—Bed 1, *Ageratum*, blue, a small variety between the old *A. mexicanum* and the new Imperial Dwarf, edged with Golden Feather *Pyrethrum*. Bed 2, *Geranium* Flower of the Day. Bed 3, *Geranium* Flower of Spring. Bed 4, *Geranium* Douglas Pearson (scarlet). Bed 5, *Geranium* William Thomson (scarlet). Bed 6, *Geranium* Sobieski (scarlet). Bed 7, *William Underwood*. 8, a narrow border in front of the cottage, is planted with a row of *Sedum Fabaria*, edged with *Echeveria secunda* and *Sempervivum californicum*. This bed is our first attempt at subtropical gardening, and as we do not like it we shall give it up. 9 is the gate.

For our spring display we had the following:—Bed 1, Centre of the bed *Alyssum saxatile compactum*, edged with two rows of *Aubrietia deltoidea*, and the whole of the spaces between the *Alyssum* and *Aubrietia* filled with choice *Tulips*. Beds 2 and 3, *Arabis lucida variegata*, edged with red *Daisies*, and filled with *Hyscynth*s.

Beds 5 and 6, *Cliveden Blue Pansies*, filled with *Tulips*. Beds 4 and 7, *Double red Hepaticas*, also filled with *Tulips*. As the *Hepaticas* had ceased blooming early, when they were over we took them away and introduced *Primroses* in their places. The narrow border, 8, had *Wallflowers* edged with *Pansies* raised from seed the previous season, with *Narcissus* introduced among the *Wallflowers*.

Nothing could surpass the beauty and usefulness of the seedling *Pansies*. The spring flowers were exceedingly beautiful, and we think even more charming than the summer flowers; indeed, when one of the most able contributors of "our Journal" came to see us during the last week in April, he declared it to be one of the best examples of spring gardening he had seen. Now, the frosty mornings have already begun to tell upon our present display, and as we have our reserve garden filled to overflowing with spring flowers, we want you to assist us in our arrangements. What we want is perfection, and any suggestions you can offer, either for spring or summer embellishment, will be considered a great favour.

Just a word or two on the merits of a few of our favourites. To enter into full particulars respecting the various plants we employ would too much increase the extent of this paper. We will just briefly refer to one or two of the most prominent, and devote a paper to the rest hereafter. Too much cannot be said in favour of *Douglas Pearson* and *William Thomeon*. These were large plants when we turned them out in the spring, and they have kept the lead of all others ever since. They produce large trusses of crimson scarlet flowers; we have counted nearly one hundred flowers to a truss. They surpass *Bayard* in size and uprightness of habit; and, therefore, we set them down, notwithstanding our friend Mr. Peach's opinion, as the best two *Geraniums* in cultivation. *Bayard* has been as good as ever this season, and *William Underwood* better than usual. We admit *Waltham Seedling* to be good, yet the individual trusses are small, and we consider one fine truss of *William Underwood* to afford as much pleasure as twenty trusses of *Waltham Seedling*. For Mr. Peach's information, among

those we consider not worthy of a place in our flower garden, we may mention *Lord Palmerston*, *La Grand*, *Herald of Spring*, *Cybilster*, *Dr. Lindley*, *Clipper*, *Christine Nosegay*, and *Indian Yellow*. Our other remarks we will reserve for another paper.—*SURAH ANN*, *CLARA*, AND *AMY ALICE*, *Geranium Cottage, Bouth*.

[We like the spring gardening so much that we would rather not meddle with the arrangement, further than to say that dotting with *Hyalinths*, *Tulips*, and *Narcissi* beds pretty well carpeted already, will have a fine effect. Even in summer grouping the carpeting of the ground with a low-growing telling plant, and then having the main plants that show at a distance rather than, has such a good effect that it ought to be more practised. We adopted it once to a considerable extent, but have not much done so lately. It is a good plan for preventing such a thing as blanks in a flower bed, and preventing even the earth being seen. All low-growing plants are suitable for this purpose, as the different *Carastiums*, such *Verbenas* as *Maonetti* and *pulehella*, *Variegated Alyssum* pegged down, &c.]

The much-prized front flower garden—which we like all the more because separated merely by a low palisading from the highway, as thus every passer-by may enjoy its beauties and be tempted to make similar efforts—is set on a parallelogram of lawn, and consists of seven clumps, a large circle in the centre, rather more than a quarter-moon on each side of it, and two smaller circles at each end. Now, the first idea that strikes us is, that your central circle is too large for the other beds, and if the colours used in it were very bright the central bed would at once arrest the eye. You seem to have had this idea present to your mind, as you fill the most of this large bed with a dwarf *Ageratum*, very nice though dull in colour, and edge it with the *Yellow Feverfew*, and thus you prevent the large bed from what we call drowning the other beds. Besides the dullness of such a mass of *Ageratum*, we have this objection to the dwarf variety, which we presume you have, that it is apt to die off or become shabby rather early in the autumn, if you cannot give it water. Of course, we speak relatively as to size, as we do not know the exact

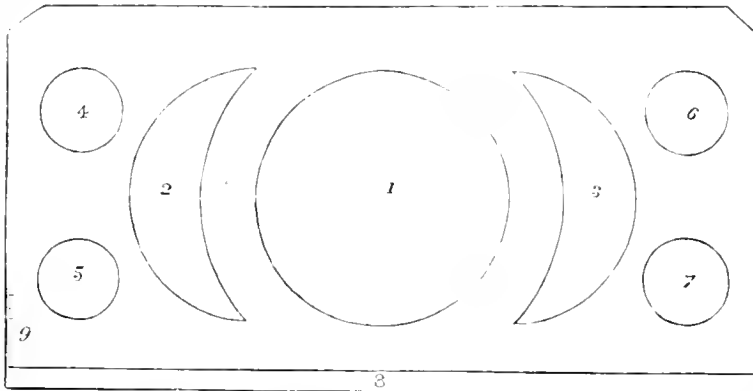

dimensions of the beds, only we see that the central clump is more than double the size of any of the rest. This may have led you to border that clump and leave the others unbordered, or without edging; but that is scarcely enough to restore the balance of size, and, therefore, that central figure would be better broken up so as not to show a mass of any one colour. Thus you might have four bands—a centre of *Coleus*, a band of yellow *Calceolarias*, a band of your dwarf *Ageratum*, and an outside band of the *Golden Feverfew*. Then, again, the central bed might be twice crossed with *Coleus* or *Iresine Lindeni*, filling up the four angles with the *Feverfew*, and having an edging round of *Variegated Alyssum* and *Lobelia* mixed. If the plants in your other beds were not too high, this central circle would look very well if the centre were made into a star, the bulk and the rays of the star filled with the *Golden Feverfew*, the six angles nestly planted with *Iresine Lindeni*, a rich purple that stands nipping to any height, and then a mixed edging of *Alyssum* and *Lobelia* all round. By drawing and painting such a figure you will judge better how it will look. Then, again, as you propose to edge this bed, we would make it a kind of key note for edging all the rest. The edging makes every bed complete in itself, and gives it a finish which nothing else will, it matters not how small the edging be.

We are a little in doubt whether, after making the large central bed somewhat neutral in its tints, it would not be as well to make the half-moons, 2 and 3, of the bright scarlets with appropriate edgings, and have the lighter-coloured foliage, as *Flower of the Day*, at the ends. In this case one circle at each end might be silver-variegated and the other yellow-varie-

gated. Even on the plan you have adopted, with light variegated foliage in 2 and 3, we would band them with a purple, as Purple King Verbena, or with strong plants of the Alternanthera, and if the end circular beds were scarlet we would band them with the larger Cerastium, or, better still, with the Cineraria maritima or the white-leaved Centaurea kept dwarf and close, and for this purpose the Cineraria bears nipping well, and, on the whole, we prefer it for its handsome cut leaves to the Centaurea, whilst it is next to hardy in most dry places.

We will not enter into your comparison of scarlet Geraniums; we may merely say, that in small gardens it is well to encourage the best sorts, and those having the best trusses. But when dense masses of bloom are to be desired rather than fine individual trusses, and if the place is exposed to wind, then we would be sorry to throw away some of the kinds you reject, as Cybister, Indian Yellow, Lord Palmerston, and the old pink Christine. We often find that these smaller-trussed kinds produce the richest mass of colouring, and they are less influenced by wind and rain. Though growing much better kinds, we have had nothing that has equalled Christine for masses of pink. Even now, on the 8th of October, and notwithstanding all the dryness, some beds are beautiful.]

EARLY FROSTS.

In this locality, on the nights of the 10th and 11th of this month, we had two rather sharp hoar frosts for the early days of October, and on the morning of the 12th the thermometer stood at 27°, or 5° below freezing.

This frost has proved destructive to many things, such as Vegetable Marrows, Scarlet Runner and Dwarf Kidney Beans, late Peas, &c.; while in the flower garden such tender plants as Heliotropes, Tropæolums, Iresines, and Perillas have been killed to the ground; therefore when these tender subjects have contributed largely to the beauty of a design the pleasure of viewing them may be said to be over for one more summer, but not so when the less tender plants of the Pelargonium class, Calceolarias, and the like have been employed. These, if the weather should prove favourable, and if the plants be cleared of their dead leaves and flowers, will considerably revive and be tolerably gay for two or three weeks; so that in looking at things one way it does seem to me to be a pity that the present style of bedding should necessitate the use of so many tender sorts of plants which very early frosts destroy, rendering a design that perhaps may be at its greatest beauty suddenly unsightly; yet the hardier kinds of plants retain their beauty for some time longer; but I suppose there is no help for it.—THOMAS RECORD, Hatfield Park.

PORTRAIT OF MR. RIVERS.

SOME friends of Mr. Rivers, of Sawbridgeworth, being desirous of expressing their appreciation of the valuable services he has rendered during a long life to the cause of horticulture by his numerous writings and discoveries, have united in a subscription to procure a portrait as a suitable memorial of one who has contributed so much to the pleasure and enjoyment of his fellows. The portrait has already been commissioned, and it is intended when completed to offer it to the Trustees of the Lindley Library, to be hung at South Kensington.

As Mr. Rivers's consent to the memorial has been obtained on the express understanding that no special application will be made to the general public, but that it shall be a spontaneous movement on the part of those contributing, no application of any kind will be issued asking anyone to assist; but all who have that feeling of regard and admiration for Mr. Rivers, by which the promoters of the movement are actuated, are invited to forward their subscriptions to Dr. Hogg, 99, St. George's Road, London, S.W.

As an illustration of the feeling of many amateur horticulturists who have derived so much healthful recreation and unalloyed pleasure from the pursuit of horticulture, as it has been popularised by Mr. Rivers, we give the following extract from a letter received by Dr. Hogg, from one of the early promoters of this memorial:—

"I am decidedly opposed to testimonials after a man is dead. The dead must depend on their own works for their fame, but the living are capable of receiving pleasure from finding that their exertions for the public good have been gratefully received. If ever there was a man who has diffused

pleasure to mankind, or, to use Virgil's expression, '*qui suis memores alios fecere merendo*,' it is Mr. Rivers. We now associate Mr. Rivers so entirely with orchard houses, that we are apt to forget his earlier but not less useful services in the introduction and cultivation of Roses and Pears, and above all root-pruning. He has managed to blend in a most unusual manner commercial advantages to himself with liberality and instruction to the public."

The following have already intimated their desire to unite in the movement, and have forwarded their subscriptions:—

	£	s.	d.
JOURNAL OF HORTICULTURE, Proprietors of	5	0	0
Hole, Rev. S. Reynolds, Caunton Manor	5	0	0
Kingsley, Rev. W., South Kilvington	2	2	0
Paul, Mr. William, Waltham Cross	1	1	0
Pearson, Mr. John, Chilwell	1	1	0
Radclyffe, Rev. W. F., Okeford Fitzpaine			
Roden, Dr., Kidderminster	2	2	0
Sparkes, George, Esq., Bromley	1	1	0
Speed, Mr. Thos., Chatsworth Gardens	1	1	0
Wilson, G. F., Esq., F.R.S., Heatherbank			

Whatever amount of money may be received in excess of the price of the portrait will be appropriated to some horticultural object of which Mr. Rivers may approve; but Mr. Rivers will regret any proposition that may assume the form of a testimonial being presented to him.

WINTER-BLOOMING ORCHIDS.—No. 9.

ADA.

A. AURANTIACA.—A solitary species represents this genus, and until quite recently it has been extremely rare. During the past twelve or eighteen months, however, a considerable number of plants have been introduced to this country in a living state, and it should be eagerly sought after by those Orchid-growers who appreciate the winter-blooming kinds; for not only is it very distinct and beautiful, but the colour is one rarely to be met with amongst plants of this order. To those unacquainted with *Ada aurantiaca*, the fact of its being so rare may, perhaps, be attributed to some difficulty or peculiarity in its cultivation; such, however, is not the case, for it succeeds admirably under similar conditions to *Odontoglossum Alexandrae*, and the fact of its remaining so long amongst our rarest plants is solely to be attributed to the difficulty attending its introduction, and to its being extremely local in its distribution.

This elegant plant produces slender, somewhat cylindrical pseudo-bulbs, which are about 3 or 4 inches long, and support two or three dark green linear leaves varying from 3 to 6 inches in length. The pseudo-bulbs are sheathed at the base with ferruginous scales. The longest scape I have seen measured about 10 inches, and was produced from the top of the pseudo-bulb, and nodding. The flowers are arranged in a somewhat distichous manner, and placed distantly on the spike; sepals and petals lanceolate, tapering to a narrow point, the petals much the smallest; all of them, together with the lip, are of a rich golden orange, a colour which is extremely rare, and very welcome at the dullest time of the year. It blooms during the months of January, February, and March, lasting in perfection a considerable time. Native of New Granada, at considerable elevations.

ANGRÆCUM.

All the species of *Angræcum*, as far as I am aware, are peculiar to Africa or the African islands. Of late years these plants have been undeservedly neglected by growers of orchidaceous plants, from no other cause that I can imagine than lack of brilliant colours. This is much to be regretted, for many of the species are noble-growing plants, and are very ornamental even when destitute of bloom. *Angræcums* should be grown in the East Indian house, should be provided with good drainage, and be potted wholly in sphagnum moss, which is best for their roots when in a growing state, independent of the pleasing effect it produces.

A. SESQUIPEDALE.—I place this species at the head of the list, for it unquestionably produces the finest flowers of any of the genus as yet introduced to cultivation, and they were first seen in this country about thirteen years ago. The plant is very ornamental; leaves about a foot long, arching, bluntly bilobed at the apex, and very deep green in colour, over which a mealy whiteness is suffused, as if dusted or powdered. The scape is produced from the axils of the leaves, and bears from three to

five thick, waxy-looking, sweet-scented flowers, each measuring upwards of 7 inches in diameter; sepals and petals broad at the base, tapering to a long narrow point; lip ovate, acuminate, and, as well as the sepals and petals, ivory white, tinged with green. The long spur of the lip, so characteristic of this genus, is developed to an extraordinary degree in this plant, reaching 14 and even 18 inches in length, and this has given rise to the specific name. It blooms during midwinter and lasts a very long time in perfection. It bloomed for the first time in Europe in the year 1857. Native of Madagascar.

A. EBURNEUM.—This is also a native of Madagascar, and being a plant of noble growth is a grand ornament in a collection, even when not in flower. It is erect in habit, and an abundant bloomer during winter. The leaves are thick and fleshy, from 12 to 18 inches in length, and about 2 or more inches broad, light green, slightly dusted with a white powder. The long spike is erect, bearing large ivory white flowers, the lip of which is furnished with a long spur. The blooms are of great substance, and remain a very long time in perfection.

A. VIRENS.—By some authorities this is considered a variety of the preceding; however, be it a variety or species, it is very ornamental and distinct. The habit of growth is similar to *A. eburneum*, but the leaves are scarcely so long, and very deep green. The flowers, though large, are smaller than those of the previously named plant, and are produced during the winter months. Native of Madagascar.

A. BILORUM.—A somewhat small-growing plant, but very elegant and distinct, and well deserving more general cultivation than has hitherto been accorded it. The leaves are arranged in a distichous manner, and are thick, dark green, obtuse at the apex. The spikes are pendulous, bearing white flowers, and the lip, as in all this genus, has a long spur or tail; they are produced during the autumn months, and with a few small fronds of *Adiantum* intermixed, they form chaste and elegant wreaths for adorning ladies' hair, and the individual flowers are charming adjuncts to a bouquet. *A. bilorum* is a rather delicate-rooting plant, or what is often called "miffy," and I have found it succeed best when planted in pieces of charcoal and of broken pots only, with just a slight covering of sphagnum moss. It is a native of the west coast of Africa.

A. PELLUCIDUM.—This is the last species of the genus which I shall introduce here as a winter bloomer. There are, however, one or two others which bloom during this season, and are extremely beautiful, but being of recent introduction and still very rare in cultivation, I have had no experience with them, and cannot, therefore, speak of them practically. The present plant resembles *Phalenopsis grandiflora* very much in growth, but the leaves are thinner in texture, from 12 to 18 inches long, and broadest at the apex. The spikes are slender and pendulous, bearing small white pellucid flowers, produced in great abundance, but even without these it is very ornamental. Native of Sierra Leone.

BARKERIA.

A genus of small-growing plants with elegant, and in some instances bright-coloured flowers. This, combined with the fact of their thriving under very cool treatment, should render them general favourites with all growers of orchidaceous plants. *Barkerias* succeed admirably upon blocks of wood, and require only a very small quantity of moss to fix them, but they enjoy an abundant supply of moisture, both in the atmosphere and about their roots. In winter the temperature may fall as low as 40°, or even lower, without producing injury, and in summer as cool and shady a place as possible should be assigned them. During the period of rest they lose most of their leaves, and at this time less water is necessary; but I am not an advocate for drying them much at any season.

B. SKINNERI.—This and its variety *superba* are, perhaps, the brightest and most lovely of their race. The stem-like pseudobulbs are about 12 inches in length, bearing narrow dark green leaves. The racemes of bloom are produced from the apex, and are erect, and from 1 foot to 1½ foot in length. The flowers are numerous; sepals and petals bright rose; lip a richer shade of the same colour, faintly streaked at the base with yellow. It blooms during midwinter, continuing in full beauty for two months with ordinary care. Native of Guatemala, at considerable elevations.

B. LINDLEYANA is not, strictly speaking, a winter-flowering plant, but as blooms are produced during the months of October and November, at which season flowers are very acceptable, it deserves more attention than is usually accorded it. In growth this plant somewhat resembles *B. Skinneri*, but is scarcely so robust, and it should be treated to a temperature a few degrees

higher than is necessary for that species. The flowers are produced in long terminal racemes, which remain a long time in perfection; sepals and petals rich purple; lip white in the centre, bordered with purple. Native of Central America.—**EXPERTO CREDE.**

NEW BOOK.

Choice Stove and Greenhouse Ornamental-leaved Plants. By B. S. WILLIAMS, F.R.H.S., &c., Victoria Nurseries, Holloway, Vol. II.

The first volume is confined to the flowering plants of the stove and greenhouse, and this is a worthy continuation of the work. The best service we can do it is to publish an extract that our readers may appreciate its contents.

ALOE.

A genus of succulent plants, admirably adapted for the greenhouse or for window gardening, containing many species of great beauty, and belonging to the order Liliaceæ. The larger-growing species with scarlet tubular flowers are the most showy, and there is a quaintness about the general habit of some of them which strongly recommends them to the cultivator. The smaller groups separated from *Aloe*, such as *Apicra* and *Haworthia*, contain many little vegetable gems, while another group, *Gasteria*, contains larger, more grotesque, and in some cases handsome-flowered species. They all require to be potted in well-drained soil, which should be mainly of a loamy texture.

A. abyssinica.—A majestic-looking plant, the leaves of which are very thick and fleshy, some 2 feet in length, and 6 inches in width at the base, tapering to an obtuse point, and there slightly incurved, dull green, and clothed at the edges with somewhat distant blunt spines. Native of Abyssinia, about Magdala and other places.

A. arborescens.—This is a very distinct and handsome species. Stem tall; the leaves are slightly spreading, lanceolate, recurved at the apex, and glaucous, margined with green. A very desirable plant. Native of the Cape of Good Hope.

A. plicatilis.—A very distinct and ornamental plant. Its leaves are thick and fleshy, tongue-shaped, and obtuse at the apex, glaucous green in colour, and arranged in a distichous manner, which has given rise to the popular name of "Fan Aloe." It is called by some *Rhipidodendron plicatilis*. Native of South Africa.

A. socotrina.—This is an elegant branching species. The leaves are somewhat erect, narrow, lanceolate, and glaucous green in colour, sparingly clothed with white spines. It is a native of Arabia and Cape of Good Hope.

A. variegata.—Leaves imbricate, somewhat spreading, and arranged in three rows, ovate in shape, and keeled at the back, in colour bright green, with transverse bands and streaks of grey and glaucous green. It is often called the Partridge-breasted Aloe. Native of the Cape of Good Hope.

POMOLOGICAL GLEANINGS.

STANDISH'S MARQUIS OF DOWNSHIRE PEACH is decidedly one of the finest Peaches I have ever fruited as regards size, colour, flavour, and habit. The fruit has been tasted by several persons in my neighbourhood, all of whom will bear testimony to its excellence.—**OBSERVER.**

ALTON TOWERS.—No. 2.

THE SEAT OF THE EARL OF SHREWSBURY AND TALBOT, ALTON, STAFFORDSHIRE.

At the head of the lake, a short distance from the Gothic temple, stands a long, square-shaped, glass structure with a span roof. This was formerly an orangery, but is now divided into three compartments, those at each end containing Peach and Nectarine trees trained-up under the roof on curved trellises, and the central compartment is a Fig house. The Fig trees were a fine healthy collection of bush-shaped trees, bearing a heavy second crop of fruit, and I was told that the first crop had been equally fine. The Peach and Nectarine trees were in excellent condition; the whole of them had a full crop of very fine fruit, and the wood, growth, and foliage were all that could be desired. Elegant columns of stone between the front sashes of this building impart to it an air of dignity and importance well suited to the commanding position which it occupies. The sides of these columns within the house were covered each with a flourishing plant of some choice Tea Rose, growing in a square wooden box neatly faced with Fir bark, and placed on the floor close to the base of each column.

Returning now, we descend the left side of the valley, and pass the grand terrace, the golden gates, and the hath garden—a small flower garden with a pretty fountain, whence a picturesque view offers itself of the alcove with its graceful statu-

ary, and part of the grand conservatories (*fig. 5*). This illustration will serve, perhaps better than any other, to convey to your readers some idea of the rich variety of the works of art with which these gardens abound, and the various aspects under which the same features of the place may be viewed from different points. As another fine example of this, *fig. 6*, presenting a glimpse of Alton Towers from the lower terrace, may be alluded to here.

Some beds of tropical plants near the bath garden were very good; amongst them were some fine masses of various kinds of *Ricinus*, *Solanum robustum*, with handsome foliage, which, together with the yellow stems, was thickly studded with sharp spines; *Solanum Warszewiczii* was also very fine. None of the pretty *Alternantheras* had succeeded very well here, but I am glad to say Mr. Rabone purposes giving them another trial.

Along the side of the walk leading to the lower terrace, a novel and pretty effect was produced by training *Rosea* on a trellis of low iron arches, between every two of which were pretty little vases containing interesting masses of compact dwarf plants. The *Roses* were not kept trim and close, but were to a certain extent suffered to present a wild rambling appearance by no means unpleasing. The numerous fine specimens of the beautiful Hemlock Spruce (*Abies canadensis*), scattered along these lower slopes are very attractive and graceful objects.

Glimpses of the pagoda (*fig. 7*), may be had from many different points, and it is, consequently, seen under a variety of aspects. From the Gothic temple its top is just visible through the trees; from the conservatory terrace it presents itself in a very favourable guise; but it is when we reach the sheet of water in which it stands down in the valley, that the singularity of this oriental structure may be best appreciated. The position is admirably chosen, for the bright colours and gilding with which the pagoda is decked out, tell well against the masses of dark-leaved Firs behind; the descending spray from the single jet of water

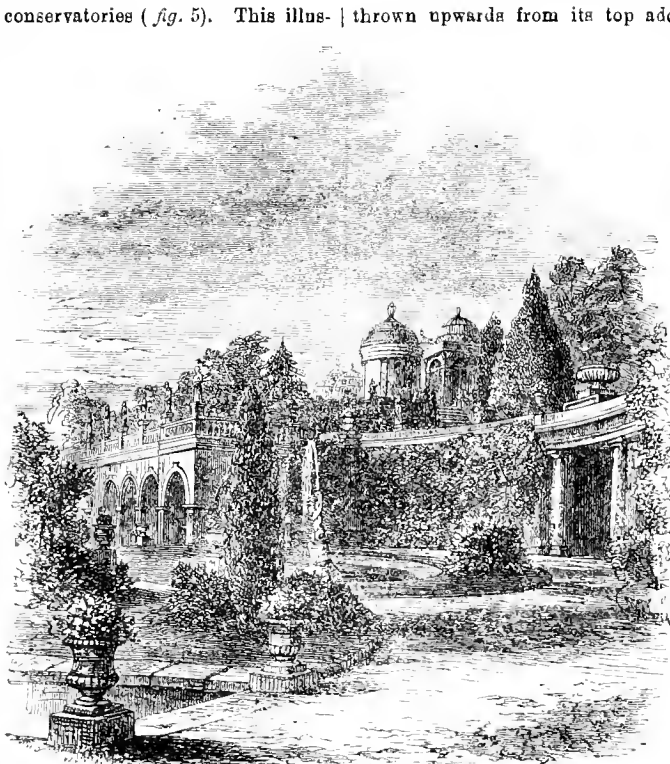

Fig. 5.—The Conservatory and Alcove.

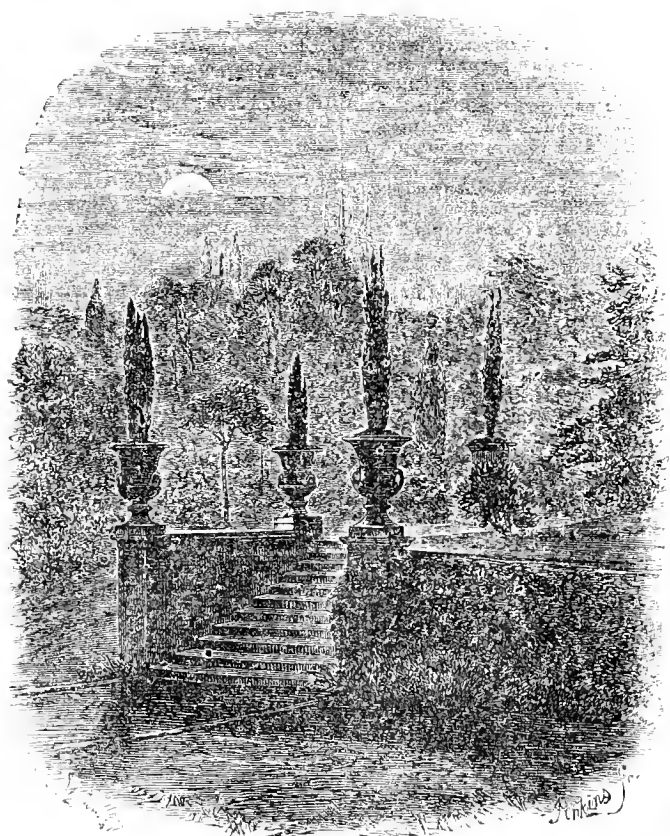

Fig. 6.—Alton Towers from the Lower Terrace.

mingling with the *Rhododendrons* and shubby undergrowth of

thrown upwards from its top adds to the effect of this uncommon scene.

Ascending the right side of the valley by winding walks and flights of steps, about half way up a seat is placed, close by some magnificent pyramidal specimens of English Yews, the fine proportions of which do great credit to the care and skilful pruning which must have been constantly bestowed on them.

Coming up from among the trees to this spot, on turning to the opening left between two of these tapering Yews, which, with their companions, are so dark, solemn, and massive, and beholding the splendour of the scene, of which, perhaps, more can be realised at a glance here than from almost any other position, we fancy ourselves gazing through the portals of gloomy night out on the brightness of the dawn.

"For sight no obstacle finds here, nor shade, But all sunshine."

The eye, soothed and rested by the greenery of the banks, the overhanging boughs, and the densely packed foliage shutting in the path by which we ascend,

"Looks down with wonder at the sudden view, As when a scout, Through dark and desert ways with peril gone All night, at last by break of cheerful dawn Obtains the brow of some high climbing hill, Which to his eye discovers unaware The goodly prospect."

The Gothic temple peeping out of the trees, the pagoda, the conservatories, and the alcove, all are visible from here, and I was forcibly reminded of the large engraving in London's "Encyclopaedia." The scene there portrayed was before me in its most important details, recalling many a boyish dream, for often when studying the pages of that masterly work have I lingered over that picture of wonderland so marvelously fair.

Higher up, the Hillside is clothed with vast numbers of *Rhododendrons* in fine health and vigour, seedlings from them growing with the freedom of weeds. The walks wind upwards in the most picturesque manner imaginable, diverging in various directions, sometimes by Fern banks alternating or

the wild woodlands, or between steep moss-clad banks verdant and cool, or else to some opening through the trees affording glimpses of scenes of beauty.

The whole of these delightful grounds are thrown open to the public, and it is very gratifying to know how thoroughly the generosity of the Earl of Shrewsbury is appreciated, for Mr. Rabone told me that very little damage had been done to any of the works of art or plants since he had charge of the gardens.

A door in the courtyard wall near the grand entrance opens on to a walk leading to a long wire arcade covered with Roses and Honeysuckles. At one extremity is an elegant alcove of stonework, with windows of stained glass, forming a charming secluded resting place, while at the other end is a flight of steps leading upwards from this retired spot to a broad promenade along the top of an embattled wall, over which the delighted glance sweeps down the valley, which is seen offering a charming general view of its rich and fanciful combination of works of art and nature. Nor is the scene so confined here as at other parts, for from this elevated position a broad expanse of turf and water comes into view, the hills forming an appropriate background in the distance.

From the end of this fine promenade a walk leads inside the walls to Lady Shrewsbury's private flower gardens, of which there are two, one on each side of a splendid conservatory. The conservatory is about 60 feet long by 15 feet wide, and has a central transept. It connects the north part of the Towers with the south. At the south end a flight of steps leads up to the vestibule, from which the doors open into the flower gardens on either side.

Around the cornice of the vestibule is painted the motto—

"The speech of flowers exceeds all flowers of speech;"

while on that of the conservatory is another equally appropriate—"Consider the Lilies of the field how they grow; they toil not, neither do they spin, yet I say unto you that even Solomon in all his glory was not arrayed like one of these."

The fine collection of plants, arranged with much taste and skill, were worthy of the building they adorned. Some plants of the pretty *Rivina humilis* with their long clusters of bright red berries were very attractive, as were some magnificent pyramidal plants of *Pelargonium*, growing in wooden boxes neatly faced with bark. A fine *Cyathus medullaris*, and an equally fine *Dicksonia antarctica*, on opposite sides of the central pathway, were singularly well placed to give relief to the flowering plants. A variety of Palms were equally effective in the same way. A striking and beautiful effect was produced by covering long circular blocks of wood with moss, in which were revelling in the rudest health a charming mixture of *Iresine Herbstii*, *Panicum variegatum*, and *Selaginella denticulata*. Out of the tops of these little pillars sprang single plants of *Woodwardia radicans* and *Lomaria gibba*, thus imparting a grace and finish. I have endeavoured to describe fully

these very suitable objects for conservatory decoration, as I think them worthy of imitation. Another singular feature was two pretty arbours, one on each side, very ingeniously formed by placing a deal box filled with soil at each end of a seat, over which a broad arch of wirework is fixed; both the arches were tastefully covered with *Cobaea scandens* and *Tropaeolum Triumphantiae* de Gand. The sides of the boxes, forming the sides of the arbours, as well as those of many others placed in dif-



7.—The Pagoda.

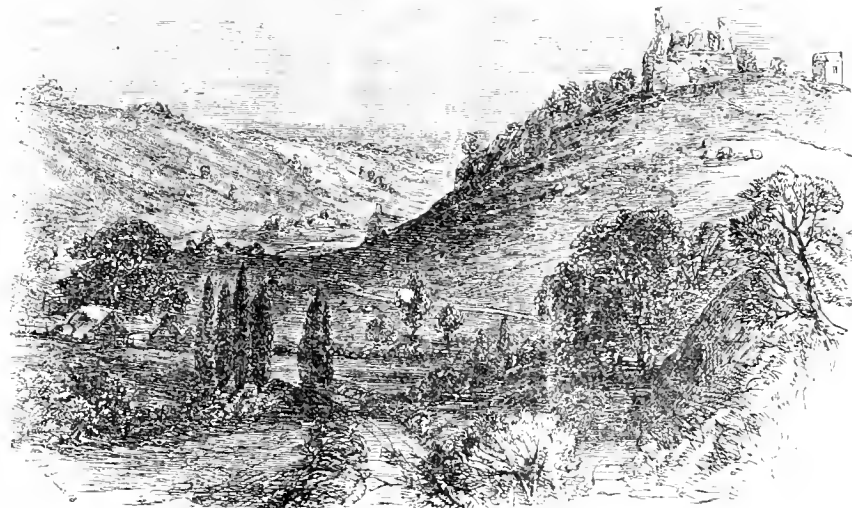

Fig. 8.—Ruins Alton Castle.

ferent parts of the conservatory, were faced with cork bark, its rugged surface causing it to form a very suitable material for such a purpose. This is another idea of Mr. Rabone's which

is quite worthy of imitation. Many of the hanging baskets contained fine masses of *Panicum* and *Iresine*: this appeared to be a favourite mixture, and certainly no two plants more suitable for such a purpose could be chosen.

Looking along the building from either end the view is one of surpassing loveliness; and although I did not see it lighted up at night, yet I could quite appreciate the truth of the remark made to me, that when so seen it was a real fairy land.

I had not time for more than a passing glance into the other glass houses near the principal kitchen garden. In the first, a span-roofed house, were a large number of medium-sized plants of *Eucharis amazonica*, admirably adapted for decorative purposes, numerous fine *Caladiums*, a good *Vanda odorata*, a *Saccolabium Blumei majus* with a fine spike of bloom, a fine plant of *Acridea suavissimum* in flower, a fine stock of *Calanthe Veitchii* and *lutea*, and many other choice *Orchids*. Some *Alocasias* and a fine plant of *Caladium magnificum* were also noteworthy.

In another house were fine plants of *Pandanus elegantissimus* with graceful, pendent leaves, *Cibotium princeps* and *Schiedei*, a beautiful *Dasylyrium*, and a *Musa* bearing a splendid cluster of fruit.

The *Cattleya* house contained a large collection of *Orchids*, very healthy and flourishing.

I must not conclude these notes without noticing the flag tower, a massive square building of six storeys, finely situated a short distance from the principal block of buildings. From the top of this lofty tower a magnificent view of the surrounding country for many miles well repays one for the somewhat arduous task of climbing so high. Far and wide can the eye range from here over the broad domains of Alton Towers, along the beautiful valley of the Churnet, away into the vast undulating expanse of country beyond. But in all this pleasant landscape no object possesses so much interest as the ruins of Alton Castle (*fig. 8*), taking us back to those old feudal days when the baron exercised a despotic sway over the country commanded by his castle—those quaint rude times when might made right. What stirring warlike scenes must have occurred where now those few old grey stones bear silent witness of the lapse of time and the decay to which all things are hastening! And as one turns from contemplating them to look once more at Alton Towers standing in all the pride and dignity of their massive strength and grandeur, it seems scarcely possible to realise the fact that these old ruins represent what was probably at one time a structure equally stately and of far greater strength.

In bidding farewell to Alton Towers I may very safely promise any of your readers whom these notes may induce to visit them, that they will find a "land of delights," a scene of loveliness surpassing what they may be led to expect, for it is hardly possible in a report of such extensive grounds to notice more than the most important points of interest.—EDWARD LUCKHURST, *Old Lands, Buxted, Sussex.*

GARDENING AT THE ANTIPODES.

STRANGE are the queries that come to us, but none that we are not pleased to receive. It is a luxury to aid anyone. It gratifies one's vanity to be consulted, as if we were "wise ones," therefore we are really doubly gratified in being able to reply authentically to the following:—

"Gentlemen, Editors—I have been engaged to be married five years to W— R—, gardener to our clergyman, and he now insists on our marriage because he has an offer of a situation in Australia, and intends going there. I have not declined out-and-out, but yet do not know what to do. I see your gardening paper on master's table every Friday, and as I see you answer inquiries about almost everything, even Blackberry wine, perhaps you would be so very kind as to say whether Victoria, in Australia, is a safe place to live in. Are there any cannibals there? Are things there anything like what they are here in Wiltshire?"

We are tempted to state our confiding correspondent's name in full, to tell who is her swain, and who is her master. We are so tempted because we should like all connected with her to appreciate her as we do, and we know we are right. We have seen her handwriting, and, like Shenstone, "judge thence of her disposition;" but we forbear, and assure her that Victoria is a place safe to live in, that there are no cannibals to fear there, and as best evidence that it is "anything like Wiltshire," we print this extract from the "Report of the Horticultural Society of Victoria for the year ending June 30th, 1870."

In return for so doing, when she, as Mrs. R—, has reached Victoria we shall confide in her reminding her husband to send us a few notes on the Victoria gardening.

"The following catalogue is a list of varieties of fruit tree scions available this year (1870) for distribution among subscribers.

"Those in small capitals are supposed to be merely *colonia* terms, and are given as the received names of varieties in extensive cultivation throughout the Australian colonies.

"APPLES.—*Mela Carla* (Charles Apple), Kerry Pippin, Gloria Mundi, Api (Lady Apple), Whatmough's Red Streak, Duchess of Oldenburgh, Kishock Pearmain, SCARLET GOLDEN PIPPIN, Maiden's Blush (American), Boston Russet, Reinette Rouge Hative, Dumelow's Seedling, Pitmaston Golden Pippin, Lodgement Nonpareil, Uellner's Golden Reinette, Red or Devonshire Quarrenden, Pine Golden Pippin, Irish Peach (Early Crofton), Brownlee's Russet, Taliesin (Norfolk Beeding), White Nonpareil, Reinette Jaune Hative, Spring Ribston Pippin, Stamford Pippin, Omar Pasha, Summer Queen, Summer Rose, Hawley, Screevton Golden Pippin, Pitmaston Nonpareil, Betty Geeson, Forge Apple, Cornish Aromatic, Summer Golden Pippin, Oslin, American Mother, Guernsey Pippin, Isle of White Pippin, White Winter Calville, Wyker Pippin, Tyler's Cromwell Pippin. BOX APPLE, Golden Reinette, King of Pippins, Court-Pendu-Plat, Winter Peach, Keswick Codlin, Golden Nonpareil, Hawthornden, Downton Pippin, Warner's King, Pine Apple Russet, Tower of Glamis, Cox's Orange Pippin, Tam Montgomerie, Early Nonpareil, Early Almond, CHARLTON PIPPIN, Wyken Pippin, Early Joe, Ribston Pippin, REN CLUSTER, Scarlet Nonpareil, Alfriston, PORT DALRYMPLE, Kirke's Golden Pippin, Byson Wood Russet, HOARY MORNING, Winter Peach, Wormsley Pippin, Beauty of Kent, American Cherry Crab, New Rock Pippin, Bedfordshire Founndling, GOVERNOR GLADE'S RED STREAK, Yellow Siberian Crab, Stone or Gogar Pippin, Rhode Island Greening, KINGSTON NONPAREIL, Pigeonette, Pearl Reinette, Phillip's Seedling, H.S.V., Claygate Pearmain, DINON'S EMPEROR, Watson's Dimpling, CLEOPATRA, Gloucester Pippin, CAERMARTHEN PIPPIN, White Astrachan, KINGSTON BLACK, Pomme de Neige, London or Five Crown Pippin, Murray's Hawthornden, Yellow Bellefleur, Franklin's Golden Pippin, English Golden Pippin, Blenheim Pippin, King of Pippins, Cornish Gilliflowr, La Sonnette, Herefordshire Pearmain, Spring Grove Codlin.

"PEARS.—*Passe Colmar*, Summer Bon Chrétien, Late Crawford, Old Colmar, Duchesse d'Angoulême, Brown Bourré, Citron des Carmes, Chinese Pear, Paradis d'Automne, Marie Louise, Nouveau Poiteau, Bishop's Thumb, Old Bergamot, Comte de Flandres, Benrre Thérèse, Fondante d'Automne, Chaumontel, Thompson's, Leon le Clerc (Van Mons), Prévost (Van Mons), Comte de Lamy, Baron de Mello, Van de Weyer Bates, Gansel's Bergamot, Summer Benrre d'Arenberg, Colmar d'Ete, Fondante des Charnaux, Doyenné Defais, Doyenné d'Ete, Benrre Clairgean, Huysbe's Victoria, Early Crawford, Surpasse Crassane, Black Achan, La Quintinie, Napoleon Savinien, Marie Louise d'Uccle, Duchesse d'Orléans, Madame Trevey, Peach Pear."

Of Grapes there are the Black Hamburgh, Muscat of Alexandria, and most of the varieties grown in England, besides many vineyard kinds. Of Cherries twenty-five sorts are enumerated, of Plums about the same number, of Strawberries two score, besides several kinds of Medlars, Peaches, Nectarines, and Apricots.

WOOLHOPE NATURALISTS' FIELD CLUB.

OCTOBER 6TH.

THE FORAY AMONG THE FUNGUSES.

THE autumnal meeting of the Woolhope Club is generally spirited and successful. It is the last of the year, and perhaps greater effort is made to attend it, and certainly the well-wooded scenery of Herefordshire never looks more beautiful than on a fine autumnal day, but the chief cause of attraction undoubtedly exists in the opportunity it affords for the study of Funguses. This is made the chief object of the day, and no effort is spared to render it as instructive as possible to all who attend. The specimens found are at once named, or if perchance they are new, or present any features of particular interest, they are discussed with a scientific zeal that cannot fail to impart itself more or less to all who are present. Thus more real practical progress in the knowledge of this difficult branch of botany is made in a single field-day with the Woolhope Club than could possibly be gained by any amount of mere closet study.

The long and lovely summer followed, as it has been thus far, by a dry and bright autumn, has so completely dried the surface of the ground that vegetation of all kinds languishes for moisture. Notwithstanding the great want of rain, the mists and the dew have occasionally been very heavy, and, where the ground is rich and not too hard, have favoured very much the production of Funguses. It is true that they who would gather them in perfection this year must not heed the poet's caution:

"The dews of the morning be careful to shun,
They're the tears of the night for the loss of the sun."

The members of the Club had certainly not shown much fear in this

direction, for the baskets of Funguses they brought with them proved that many a successful foray had previously been made. In addition to these a large hamper had been kindly sent from Whitfield. Holme Lacy and Haywood Forest supplied the Vegetable Beefsteaks, and Mr. Worthington G. Smith most thoughtfully brought down a selection of the Funguses with which he had won the prize the day before at the Royal Horticultural Show at South Kensington.

The great success of the exhibition of Funguses was thus assured, and while several gentlemen most diligently occupied themselves in writing their names and arranging them on the tables provided, the rest, with Elmes Y. Steele, Esq., in the chair, proceeded to transact the ordinary routine business of the meeting.

The members of the Caradoc Field Club had been invited to join in the day's proceedings, and were represented in the field by the Rev. E. Donald Carr, the Honorary Secretary, the Rev. J. D. La Touche, and several other gentlemen. In their honour the special district from which the club takes its name was to be visited, and the road was first taken for Hagley Park, about four miles east of the city. Here they were kindly welcomed by Arthur Hutchinson, Esq., and proceeded at once to examine the quarry which has so special an interest for the members of the Woolhope Club.

Minute and careful as were the researches of the officers of the Ordnance Survey in this district, the existence of an upheaval of Silurian rocks at Hagley Park entirely escaped their notice. The discovery of this quarry in which they are so manifestly shown was the first feather in the cap of the Woolhope Club. It was made by the late M. J. Scobie, Esq., who worked at it with all the intelligent zeal for which he was so distinguished. He took the exact dip of the strata, noted their characters, measured their thickness, and collected their fossils, until he had quite satisfied himself with the reality and importance of his discovery. He then invited the late Hugh E. Strickland, Esq., F.R.S., F.G.S., reader in geology at Oxford, to come and see it. Mr. Strickland fully confirmed Mr. Scobie's observations, and wrote a paper on the subject, which appeared in the Quarterly Journal of the Geological Society.

The general facts and conclusions of this paper were given to the gentlemen present, with an account of the erustacean fossil found here by Mr. Scobie. It proved to be the *Pterygotus problematicus* of Agassiz, and it was afterwards figured and described in the Quarterly Geological Journal of J. W. Salter, Esq., F.G.S.

It was decided that these papers of Messrs. Strickland and Salter should appear in our own Transactions—meanwhile an active examination of the rocks was being made and many fossils were found. This celebrated "Ludlow Bone bed," described by Sir Roderick Murchison in the "Silurian System," is unquestionably represented in this quarry. It occurs between the Downton Sandstone and the Upper Ludlow Shale, and varies here in thickness from that of a wafer to 1½ inch in some places. The quarry was not being worked near the junction at this time, but a search was made specially for it, and with the aid of a man and a pickaxe some few spines were found on October 6th.

The Rev. J. D. La Touche said this bone bed varied very much in thickness in different localities, as might be expected. At Corston, Salop, it was as much as 6 inches in thickness, and consisted almost entirely of a mass of scales and teeth and bones of fishes broken up and waterworn—what these fishes were is not known with any certainty.

Leaving the quarry the hunt for Funguses beneath the Oak trees in the park began most unsuccessfully—not one was to be seen; but here, as everywhere else, the abundance of acorns could not fail to be observed, and the wonder was expressed why they were not systematically collected. When crushed and given in small quantities to sheep and pigs, acorns form a most nourishing and useful food. At a time when fodder is so scarce as it is this year, it does indeed seem strange that this prolific source of food should be so much overlooked. The Horse Chestnuts, too, are still more neglected, and yet it is stated positively, that when crushed, cows will eat them readily and give an increased supply of excellent milk. This year they, too, are very abundant and fine, and it is said that their only use should be as playthings for children to string and hang round their necks. Will no one give village children the delight of collecting them for some small recompense, make experiments with them in feeding cattle and horses, and publish the results? As a scientific society, the Woolhope Club can say they are certainly not poisonous, and equally sure is it that they are nutritious, but whether the animals could really be got to relish them, and if so the best way of inducing them to do so, are points that have yet to be discovered.

Two fine Lombardy Poplars grow in Hagley Park. They are believed to be the largest and tallest in the county. At 5 feet from the ground they measure respectively 12 feet 10 inches and 14 feet 1 inch in circumference. They stand out boldly all alone, and spread out their boughs in a way that conceals their height, and yet the tallest by shadow measurement was made 132 feet high. Each tree sends out from its bole strong buttresses towards the north, the latter to resist the winds they are exposed to.

At the foot of one of these trees some fine Funguses were found. They were thought to be *Agaricus* (*Phohota*) *pedunculatus*, and from their fragrant smell and pleasant taste, which many tried, were also judged to be edible. On reference to the best authorities both surmises proved to be correct.

Some 50 yards from one of the Poplars stands the Hagley Park

Elm, and this grand tree was next visited. It has still a fine upright bole, almost free from the excrescences to which Elms are so liable. It gives in fair measurement, 22 feet 10 inches in circumference at 5 feet from the ground. It is long past its prime, has lost its top and many boughs, and is partially hollow, but it is still a noble well-balanced tree. It was greatly admired, and the wish several times expressed that it might be photographed for the Transactions. In the same field another luxuriant Elm gives a circumference of 14 feet, and thus adds its testimony to the richness and strength of the soil below.

Near the east entrance at the cross road stands an Elm which figures as a boundary tree on a map of the estate with the date 1731 upon it. Its girth is only 11 feet 9 inches, and it is given simply as a notable tree.

The celebrated trap dyke at Bartestree was the next object on the programme. The fine high pasture field leading to it was searched in vain for the Funguses, which must commonly grow there, nor did it today give the pleasure it usually does to its visitors, for a mist hung over the scene, and rendered but dimly visible the well-known clump of Fir trees on the summit of Blackbury Hill, which had yet to be surmounted.

The geologists were interested, as they ever must be, with the well-known dyke of greenstone at Bartestree. It has been thrown up in a fissure a few yards wide, through horizontal strata of old red sandstone, and by its intense heat at the time has baked the sandstone into a dark friable mass. It has now nearly all of it been quarried away for road-mending purposes. The remainder should certainly be left as an object of the deepest scientific interest.

On leaving this remarkable basaltic dyke, a lofty and most luxuriant bramble bush, hung with sable fruit more than usually fine, attracted attention. It was a striking and uncommon variety, but happily the highest authority for this puzzling genus was present, and on being appealed to, Mr. Lees pronounced it to be *Rubus radiis*.

The way was then taken for the high road, but a very interesting halt was called in the corner of a Barley stable field, just below the convent. Beneath the drop of a hedgegown Oak some Funguses were found of a very peculiar character. They were judged at first to be the *Scleroderma vulgare*, with its usual centre of dark blue sporules, opening in a peculiar stellate way in consequence of the dry weather. Mr. Broome, however, at once remarked that the stellate markings were visible on the immature Funguses, and he pronounced it to be *Scleroderma gaster* of Fries, which we may call the Star-like *Scleroderma*. This variety, though often looked for, has never before been found in Britain, and thus a marked addition to British Fungology has once again been made by the Woolhope Club.

The carriages were again taken at the Longworth entrance lodge for the foot of Blackbury Hill. At the Priors Court Farm they were left, and the ascent of the hill commenced through the dense covert which clothes its sides, all beautifully variegated as it was by the touch of autumn. Amongst

"The tints of rich and roscate hant,"

the leaves of the wild Gaelder Rose, *Viburnum Lantana*, here at home upon limestone, and the almost bloody hue of the Spindle tree, *Euonymus europæus*, were eminently conspicuous, contrasted as they were with the pale orange of the Maple, and the varying hues of the fading leaves around them.

Blackbury Hill has several botanical productions of interest, among which the Green Hellebore, *Helleborus viridis*, may be noted, while the masses of Virgin's-bower, *Clematis Vitalba*, flourish with such graceful exuberance as to arrest attention at every step.

The hill is formed by the Aymestrey limestone, which at the summit is broken up into great masses of exposed rock, with such deep cavities and passages interposed between them as to suggest some violent cataclysm having taken place on the spot, rather than that slow wearing away by the tooth of time, as was contended for by the Rev. J. D. La Touche. Traces of violence here seemed evident, though whether by the gunpowder of man in blasting the limestone of the quarry or the earthquake's titanic effort in ages past, there is no record to show. There is a very interesting camp on the summit, with a double entrenchment towards the east, and a covered way, which may not now be dwelt upon. The exposed precipitous masses of fractured rock are commonly called "Adam's Rocks," or sometimes "Hatton's Rocks," but from what circumstance the name is derived, whether legendary or historical, is not known. Whether some glorious old chieftain of that ilk held the camp successfully against all comers, or whether some inglorious rascally Adam, or Hatton, may have broken his neck here on a misty November eve, there is no certain information forthcoming. Be this as it may, the visitor to this spot, whether of a geological or poetical turn of mind (though he must be careful how he turns his body), will be charmed with the prospect before him; the coloured woods, the verdant dales, the holdly rising hills, the distant views stretching on beyond the curvatures of the sparkling Wye to the Black Mountains, bounding the horizon, may not readily be forgotten when once they have been seen. On the present occasion, however, the break of sunshine had unfortunately disappeared, and a tantalising brooding mist,

Like sorrow's veil on beauty's brow,

as Anacreon Moore writes of a like, "Mist o'er blooming bowers," about famed Killarney, now hid the distant prospect, and even dimmed the celebrated Haugh Wood, the dome from which the other rocks of the Woolhope Valley are thrown off subordinately.

The company were here assembled by the sound of the whistle, and

having accommodated themselves to the inequalities of the ground. at the request of Dr. Bull the Rev. P. B. Brodie, M.A., F.G.S., gave a very interesting extempore lecture on the geological features of the Woolhope Valley before them, comparing the remarkable features of this district with the more extended one of the Wealden in Sussex.

In the course of this address Mr. Brodie mentioned that when working in the Woolhope district this spring, with his own Field Club, he had been so fortunate as to discover a small and very perfect specimen of *Eurypterus*, which he had sent for examination to Mr. Henry Woodward, of the British Museum. He had just had a letter from Mr. Woodward, in which he stated that it was a new species, and that he had named it the *Eurypterus Brodiei*, in honour of the finder. It was found at the Parton quarry, near Stoke Edith, and as it came so strictly within the province of the Woolhope Club, Mr. Brodie kindly offered it for illustration in the volume of Transactions, an offer which was very gladly accepted.

The order was now given to search for Funguses, but although the district was most favourable for them, beyond the large tufts of the ubiquitous *A. mollens* and *A. fascicularis* but little was found. Many small specimens of the orange *Chantarella*, *Cantharellus unrantiaeus*, were gathered; Mr. Houghton found the Fir-cone *Hydnum*, *Hydnum ariscalpium*, always so curious and interesting; Mr. Elmes Y. Steele got the graceful green *Agaric* with its silky veil and stem, *A. aruginosus*; several of the *Myccena* tribe were also gathered, as *A. polygrammus*, *A. alcalinus*, with one or two near allies, *A. epipterygia* amongst them. These are sufficient to show how many more there would have been under more favourable circumstances. The drought was too prevalent, and *Agarics* could only be numbered by noits instead of by scores, as fondly hoped for, but as a popular poet has said—

"We may roam through this world like a child at a feast,
Who but sips at a sweet and then flies to the rest;
And when pleasure begins to grow dull in the east,
We may order our wings and be off to the west."

And so on the present occasion the disappointed fungologists drew off from the wood to the open ground on the shoulder of the hill, and visited the two stunted Hawthorns, so oddly called "the Cow and Calf." The view from this spot is usually most extensive and beautiful, but at this time it was enshrouded in mist, and since the Funguses were again absent the descent was made to Old Sinton, where the carriages were waiting to convey the visitors to Hereford.

The ride home would have been very pleasant but for the myriads of aphides which swarmed in the air. It would almost seem true that

"The thin-winged flies their transient time employ,
Reeling through snubbeams in a dance of joy."

The Turnip aphid, however, has been terribly destructive this autumn, and a field on the hill was passed smelling horribly from the decaying bulbs of the Turnip plants they had destroyed.

An examination of the Funguses, at the Green Dragon, brought for exhibition passed the time remaining before dinner very pleasantly. It was an extremely interesting collection, and the only wonder was that in so dry a season so many could have been produced.

The most striking specimens were the arborescent Funguses, as might have been anticipated. A huge specimen of *Polyporus frondosus* was placed in the centre of the table, and undoubtedly carried off the palm both for interest and novelty. It weighed no less than 14 lbs., and from its great size, the beauty of its lines, and its gracefully overlapping pilei, it proved the chief attraction in the room. This species may be said to be virtually new to Britain, for although its presence has been more than suspected by several botanists, it is not given as British in any of our flora, not excepting Mr. Cooke's recent handbook. It is true that Mr. Berkeley published a species under this name in the English flora, but he afterwards corrected himself and referred his former plant to *P. intybaceus*, leaving out *P. frondosus* altogether. A specimen of *P. frondosus*, gathered at Whitfield, was sent by Dr. Bull to the exhibition at South Kensington; and, besides the grand one brought to this meeting by J. E. Smith, Esq., from near Hay, there was another from Whitfield, and also a very fine one brought by the Rev. W. Houghton from the Wrekin. We have now, undoubtedly, in England all the three species of Fries:—*Polyporus frondosus*, known in addition to other characters by its pore-surface and its flesh turning grey when bruised; *P. intybaceus*, with its hundreds of pilei tufted together, very much branched, and smelling like mice; and the *P. giganteus*, with its large imbricated pilei, turning red when bruised, and smelling horribly like rotten cheese.

There were also very fine specimens of *Polyporus applanatus* and *P. hispidus*, with *P. rufescens*, *P. fumosus*, *P. varius*, *P. annosus*, and the ever-present *P. squamosus*.

The next Fungus which created much interest was a fine specimen of the edible *Sparassis crispa*, brought by the Rev. W. Houghton from the Wrekin. It was the size of a Cauliflower, of a bright orange colour, and very pleasant fragrant odour. It is very rare, but has been found this year in several localities, as attested by the Rev. M. J. Berkeley and C. E. Broome, Esq.

Two fine sturdy specimens of *A. corticatus* were exhibited. They were found growing on a Beech tree, and possessed considerable interest, as well for their great beauty as for the great rarity of their occurrence in this country. *Agaricus porrigens*, a beautiful snowy white *Pleurotus* of great rarity and beauty, peculiar to fallen Pines, was sent from the Duke of Argyll's plantations at Inverary. The rare *Cortinarius fulgens* was there also; *Lactarius deliciosus*, rufus,

tormentosus, *vellereus*, and *controversus*; *Russula rubra*, *fragilis*, *lepidia*, and *ulmata*; *Boletus luridus*, *edulis*, and *versipellus*; the *Agaricus Cecilia*, *procerus*, *rufescens*, *maculatus*, *rutilans*, *squarrosus*, *rimosus*, *nudus*, *tuberosus*, *gallinaceus*, *butyraceus*, *lacrymans*, *infundibuliformis*, &c.; *Pistulina hepatica*, *Paxillus involutus*, *Hydnum udum*, *H. repandum*, *Helotium vergulatum*, &c.

A very puzzling lot of sulphur-coloured *Agarics* was brought by Mr. Houghton, which seemed to agree with no known group. They were, however, provisionally referred to the rare *A. (Flammula) inopus* of Bolton, or perhaps *A. hybridus* of Fries.

A great variety of common *Agarics*, which it is unnecessary to mention, were conspicuous by their absence.

There was some little difficulty in procuring sufficient edible Funguses for the dinner, but the following dishes were sent round with more or less satisfaction:—*Pistulina hepatica* fried, and finished in its own gravy; *A. deliciosus* stewed; *A. procerus* and *A. rufescens* broiled. The novelty of such dishes is now over with the Woolhope Club, and it becomes difficult to take the opinion upon them. *Procerus* was most asked for again, and may be supposed, therefore, to take the place of honour.

After dinner the President called upon Edwin Lees, Esq., F.L.S., &c., to read his paper "On some curious *Agaric*, only apparent in times of drought, with notices of those that occur and colour water at seasons of high temperature," and Dr. Trimen, of the British Museum, made some remarks upon it.

The following papers were also read:—"The Fungi which affect our Forest Trees," by Worthington G. Smith, Esq., F.L.S.; "Notes on Fairy Rings," by Jas. Buckman, Esq., F.L.S., &c.; and "Illustrations on the Edible Funguses of Herefordshire," by Dr. Ball. These papers, with such discussion as they elicited, will be published in full, and it only remains now for us to say that they were of high interest, and gave much entertainment to the members present.

NOTES AND GLEANINGS

ROYAL HORTICULTURAL SOCIETY'S COMMITTEES.—The next meetings of the Fruit and Floral Committees are to be held on November 2nd, and December 7th; and not November 16th, and December 21st, as previously announced in some of the early issues of the schedule and almanac.

—AMERICAN WINTER GARDEN.—*Nature* announces that the United States Congress has granted 30 000 dols. for the erection of a Government Winter Garden, either at New York or Washington, somewhat similar to that at Kew, but on a smaller scale. This will partake partly of the nature of an economic garden, in which useful plants can be raised and then disseminated far and wide throughout the States.

—CINCHONA CULTIVATION has so well succeeded in the English hill settlement at Darjeeling, in the Himalayas, that last year 5000 lbs. of bark were sent to London from Cinchona trees planted in 1862, on one plantation. Tea produced, in 1869, 1,319,713 lbs. from 10,769 acres of hill land formerly said and reputed to be worthless, and unsuited to give a return to Englishmen. We shall now hear of Indian bark as well as Peruvian, as we know Indian Tea to hold its own against Chinese. The Cinchona trees are also taking well in Jamaica. Experiments on the culture of American Tobacco in India are being made by the Maharajah of Burchwan, in Midnapore and Cuttack. The last year's experiments with seeds from James River, Virginia, were very successful.—(*Nature*.)

WORK FOR THE WEEK.

KITCHEN GARDEN.

THIS is an excellent period for laying down the spring *Broccoli*. It is best performed by two persons, one at each side of the row. Keep a good trench, and sink all the heads to the north, hurrying the stems in soil up to, and even amongst, some of the lower leaves. This proceeding will protect the heads very considerably against a severe winter—first, by reason of the position; secondly, by avoiding sudden changes or excitement; and thirdly, by the reduction of succulence. Pull *Cauliflowers* before they grow too large, and prepare a shed or pit in which to plant a quantity on the first approach of frost. *Dwarf Kidney Beans*, remove those growing in pots to where they can have the protection of glass. It is no uncommon or new practice for good kitchen gardeners to throw their overgrown *Lettuce* or *Cauliflower* plants on the ground to shrivel before planting them. Plants in this state will endure hard weather better than those in luxuriant growth. Remove the leaves from *Rhubarb* and *Sea-kale* that you intend forcing very early, and keep a look-out for slugs and weeds.

FRUIT GARDEN.

Pay every attention to getting the wood of Peaches and

Apricots well ripened by exposure, shortening, &c. Put the ground in order for planting all kinds of fruit trees. On cold stiff soils it is advisable to plant on hillocks 1 foot or 18 inches higher than the surrounding surface. The trees will not grow so fast in consequence, and will require more attention in summer in the way of mulching, but they will form short-jointed, well-ripened, fruitful wood, which is the best preventive of canker, gum, &c., and will save the labour of resorting much to root-pruning.

FLOWER GARDEN.

I would urge the necessity of taking advantage of the first favourable opportunity to plant the main bed of Talips; every week that they remain unplanted will be prejudicial to them, though I make no doubt many will put off planting till the middle of November. All bulbs which have been reduced in size should be removed from the position they hold in the best bed, and be planted in a side bed to recover their strength previous to being reintroduced, and their place should be occupied, if possible, by some other variety which will nearly correspond with that taken away. The amateur must ever keep in mind the necessity of preserving the uniformity of his collection. After another week or ten days I would advise no one to remove Carnations: it will then be late for them, and it is so important they should be well established previous to the coming winter, that no time should be lost. Auriculas must be carefully preserved from heavy rain, and a watchful eye kept on the surface of the pots, which will speedily indicate where the drainage is bad. As the winter approaches protection of some kind should be provided for plants and shrubs of tender character; almost any material is eligible, provided it will in a considerable degree throw off wet. Canopies for this purpose should be so contrived as to admit of one or two sides being opened at pleasure; if only one, it is advisable to place it on the north or west side, certainly not on the south side, as the excitement caused by bursts of sunshine is apt to prove very prejudicial. The covering or canopy should by no means be allowed to touch the plant, and the greater the space allowed between it and the plant the better will it afford protection. It is a bad practice to bundle the shoots together like a besom, in order to make them occupy a more limited space; doing so may save trouble and material, but is a most injurious proceeding. More injury is occasioned by confined damp in a majority of cases than by lowness of temperature. Hoodings of straw, so formed as to overlap the protecting material beneath, are very good and simple protectors, and, if rightly contrived, may be removed with as much facility for ventilation as the top of an ordinary hand-glass. Oilcloth will also form a good protection if made into a kind of cone, on the sides of which a small flap or two may be made to open without admitting the rain. Before the application of any top covering, it is advisable that an inch or two of the surface soil around the collar be removed, and replaced with dry sawdust, the newer the better. This should be piled as high as the stem of the plant will admit, taking care not to choke too many of the lower leaves; and if the canopy is so contrived as to overlap the mound, the covering will be complete. The only thing that remains is to give air at favourable opportunities, avoiding cutting winds, which in all probability do more harm than the frost.

GREENHOUSE AND CONSERVATORY.

Proceed according to former directions; see that all plants belonging to the conservatory are housed forthwith. Do not be flattered by fine weather, such as at this period usually flatters to betray; cleanliness, free ventilation, and clever arrangement, are the main points. If severe weather should occur do not hesitate to use a little fire heat at times, especially where many plants are blooming, as by these means a free ventilation may be indulged in to expel damp and stagnant air. A mere hibernatory is another thing; in this, whether the roof be of glass or opaque, free ventilation will be all that is requisite for some time to come. By means of Roses, Chrysanthemums, and other late-flowering plants, this structure may yet be kept gay for many weeks. Supply them occasionally with manure water in a clear state. It should be administered about 5° or 10° warmer than the atmosphere of the house. If the water is just coloured it will be sufficient. An ounce of ginseng with a handful or two of soot will make a large bucketful or canful strong enough for anything, and it ought to be provided as clear as fine ale. Damp and mildew are the great enemies to be guarded against at present in conservatories and greenhouses, and these must be sharply looked after, especially in the case of plants that have not ripened their growth, and are in a rather soft state.

If damp is troublesome it must be dispelled by means of free ventilation in mild days, using a little fire heat at the same time, and for mildew a dry airy atmosphere is the best preventive; but the plants should be frequently examined, applying sulphur on the first appearance of the evil. Very little water will be required at present, but the plants should be carefully looked over about twice a-week to make sure that nothing is allowed to feel the want of it. If not already done get plants tied into proper form with the least possible delay, for it is difficult to tie a plant so that it will not look somewhat stiff and unnatural, and the sooner all this kind of work is done the better the specimens will look when in bloom.

STOVE.

Much less moisture will suffice at this period, even for the growing Orchids; keep the temperature progressively on the decline, more especially in dark weather. Ventilate freely whenever the weather will permit.

COLD PITS AND FRAMES.

Cold pits will now be in request. Sawdust forms a good plunging material, if new and dry; coal ashes are also very good. Whatever material is employed, keep the plants within a foot or so of the glass, and endeavour to keep the soil in a somewhat dry state. A portion of the stock of Roses, Lilacs, Honey-suckles, &c., in pots, may soon be placed in a pit to have a slight advance of temperature. The present is a good time to procure from the nurseries or the reserve garden a supply of Rhododendrons, Azaleas, and Kalmias, for forcing. Select plants well set with bloom, and of the desired size. Some of the hybrid scarlet Rhododendrons, as Nobleanum, and others, require but little forcing, and are the best to start first. Place them in as small pots as their roots can be got into without injury, and set them out of the reach of frost till wanted. Abundance of air and light must be admitted to these structures. If any of the lights afford a partial shade to the plants from the accumulation of dirt, take them off and wash them thoroughly without delay. Be careful to supply water only to plants that require it. Remove all mouldy and decaying leaves, and keep the interior as dry as possible during dull foggy weather. If you discover the unwelcome presence of the green fly upon your plants fumigate them with tobacco, which will put an end to them for this season. All half-hardy plants which it is desirable to secure for next season, may be potted with balls and wintered in these structures.—W. KEANE.

DOINGS OF THE LAST WEEK.

THE rains came as we expected, and though not in the deluges spoken of in other places, yet in sufficient quantity to give us water for some time to come. More trying, perhaps, than the rains were the frosty mornings and the hurricane of the 12th, which tried many trees and shrubs, and did a little injury among our glass, though we thought all was securely fastened. The heavy showers, the wind, and even the frost have left the flower gardens still passable on this the 15th inst., except some fine beds of Coleus, from which the leaves are dropping. The Iresine is still quite fresh, and the Heliotrope is only slightly marked in places. But for the lashing of the wind and rain Calceolarias would still be fine, and scarlet Geraniums are very passable, showing a good deal of bloom, though even Cabbage leaves on some mornings were quite hard with the frost. The frost and the rains together have done more than all our care to eradicate the legions of Cabbage fly, that but for being warred with would have carried all before them. It is sad to hear of the wrecks they have left in many places. We may also add that Vegetable Marrows have had their leaves considerably blackened by the frost.

KITCHEN GARDEN.

The work was much the same as last week, and chiefly consisted in earthing-up Celery when fine, pricking-out Lettuces, blanching Lettuces and Endive, taking up Carrots, Parsnips, &c., and preparing for the first Cauliflowers of spring by giving a little fresh lime to the ground to drive away the slimy tribe and make the ground more mellow, and the old organic material in the soil more sweet and soluble. There is hardly an old kitchen garden that a moderate *lime-dressing* would not improve. If the soil were light it would make it more retentive of moisture. If stiff and heavy, it would make it more mellow and open; and though, looked at as manure, it will do little good on poor land, it will increase the fertility of all soils

that, like kitchen gardens in general, have been well supplied with manure.

FRUIT GARDEN.

Most of the hardy fruit is now gathered, though a few of the latest will be housed the first bright dry day, as they will not do much more good now, though late Apples and Pears swelled freely recently. Looked over the fruit room to keep all sound, and gave a little air to allow the sweating to escape. Peaches on the walls have been over for some time, and the last in the orchard house are now nearly over. There are a good many Plums still, and, with proper arrangement, in a late Plum house we believe they could be had in fine order a month or six weeks later than it would be possible to have them out of doors on walls. Grapes in another orchard house have ripened well, but that is not much in such a season as this, when in many places not only in the south, but considerably north of London, they have ripened well out of doors. We took the lights off the Peach house, not so much for exposing the trees thoroughly, as to get the lights themselves thoroughly cleaned and renovated. The trees and house will be effectually cleaned before they are replaced, as red spider made its appearance after the fruit was gathered.

The Strawberry plants for forcing which we could get rather late, are making rather large leaves for our taste, and by turning the pots on their sides in wet days we must try to have the fine buds well ripened. A number of the most forward we have put on the north side of walls, &c., to give them a rest before starting them afresh. Melons are now nearly over, and the places occupied by them will come in most useful. In fact, room is now so valuable that every house as it gets empty of fruit must be cleared and filled temporarily with plants. An earth pit sown with Kidney Beans in July, is now giving fine returns with the help of protection at night.

ORNAMENTAL DEPARTMENT.

Similar notices to those lately made respecting fruit trees would hold good as to planting ornamental trees and shrubs, and trees and undergrowth for plantations and covers. After the rains these will soon lift and plant well even in this dry neighbourhood; and planted at the end of the month they will, whilst the ground is warm, have two chances to one of doing well as contrasted with planting in spring. In places where game is all in all, it is but labour and money thrown away, if no protection with wire netting be afforded; and for small rabbits the meshes of the netting must be very small—not more than $1\frac{1}{2}$ inch. Wherever a young rabbit can squeeze his head in flat he will manage to pass his body in afterwards, and then he will soon grow too big to get out at a similar opening, and the trees and bushes will form an irresistible attraction. We noticed lately a communication recommending sinking such netting in a little trench 1 or 2 inches below the ground level, so that the rabbits might feel the net when burrowing. We thought it a good plan at first, but soon found the rabbits cared nothing for this wire, going down easily, and as a matter of course beneath it. A far better, because a more perplexing plan to the rabbits, is the following:—Prepare yourself with stout pegs and stakes, the latter, after going firmly into the ground, to be as high as the width of the netting; unroll the netting and stretch it out, flatten down the side next you, which will be the outside of the fence, and pin down to the ground the netting, leaving from 1 to 2 inches on the level outside the hooked pins. Then begin at one end, and raise the netting straight and level, and fasten to near the top of the stake inside with a small wrought iron nail driven in obliquely against the wire. This is, perhaps, the most simple, secure, and effectual mode of fastening such netting, because based on the habit of the rabbit of beginning to burrow close to the upright fence. He thus comes in contact with the horizontal pinned-down part of the netting, and seldom has the philosophy to go further back and make a fresh trial.

Followed up what was lately recommended in taking under cover the most tender plants which were exposed. A few more Cinerarias had their largest leaves a little blackened by the frost. Proceeded with potting and moving, and as soon as some fruit houses are empty we shall thoroughly clean them, and then fill with Geraniums and bedding plants, where they will be secure for the worst, coldest, and darkest months of the year.

We have yet taken nothing up from the flower garden, but the small cuttings put in are doing well. For a particular reason we do not wish to break the outline of the beds and

borders until the end of the month, as the grass looks lovely, and the gale of the 12th has cleared away all the most forward deciduous leaves from trees, as well as all those that had fallen, taking them miles away into the fields, and leaving the lawns cleaner than if carefully swept. We only had to pick up some barrowloads where they had rested against flower beds and borders.

When a beautiful lawn has been disfigured in the autumn months by the fallen leaves of deciduous trees, we have often wished to have a flower garden where no leaves of deciduous trees could mar its beauty, but where the greenness of the Laurel, the Holly, and the Pine tribe, should contrast with and show off the beauty of the bright colours in the beds and borders. It so happens, however, that no one definite mode combines in itself every advantage, for if evergreens are thus beautiful at all times, and give little trouble in spring and autumn, they do give trouble by the dropping of their older leaves in summer, requiring much moving and sweeping up in the brightest days of the year.

Though we have taken up no Geraniums as yet, if we saw signs of a sharp frost we would lift some of the most tender, as the variegated kinds, and others of which we might be scarce, and place them under cover until we could arrange them properly. In the meantime it will be useful to mix tree leaves and short grass with long litter, so as to be able to give a little bottom heat to subjects we wish to root quickly.

As respects Geraniums in beds, we submit the following as hints to beginners who do not like the idea of the frost making wrecks of all their fine plants:—

As respects all Tricolored and merely Variegated Geraniums, they will do best, when taken up, if the larger leaves are all removed, leaving the smaller ones, shortening any very long roots, and cramming the rest of each plant into a small pot, plunging the pot in a mild bottom heat after watering it, and giving air at top except in severe frost. Such plants will soon make fresh roots, and they will do better if the plants, or rather the pots, stand on a dry board.

Where there are some fine-grown large plants of Geraniums, and it is desirable to keep them large, take away every leaf larger than a shilling or two-shilling piece, shorten the very longest roots, place the rest in the smallest pots that will contain the roots, plunge as stated above, and when rooted place the plants on a dry shelf. Success here, as regards large specimens next year, will depend on the shoots not being shortened, the axis of growth being kept sound, and having plenty of air, light, and heat to keep them slowly growing all the winter.

A third mode, more applicable for rough treatment, is to take up the plants, shorten all the shoots a little, remove every leaf, pack the roots closely and firmly into pots or boxes, so that the box or pot above the soil will look like a bundle of wood faggots; water, and when dryish on the surface, cover with dryish soil. These will thrive in any place from which frost is excluded, if cool enough not to encourage growth, but when the stems break about March, they must then have light in fine days, and in another month be thinned. These will make fine plants for the centres of beds in the following year.

A fourth plan to secure dwarf plants for next season, is to cut such plants down some 4 or 6 inches from the ground, remove every leaf, dip the points of the shoots in lime and charcoal dust, and treat roughly as above; in any place tolerably dry and free from frost, they will need little light even until the plants break afresh. We have known, however, many cases where some hundreds of such plants have been kept in little space all secure during the winter, in a spare room or a hayloft, and then all killed by exposure to a few hours' severe frost in March. Keeping in this rough way, and flowering well in future, depend on just keeping the plants alive, and not encouraging fresh growth at all. Wherever we have growth and fresh leaves, there must be light and air, as well as enough of heat to keep out frost.—R. F.

TRADE CATALOGUES RECEIVED.

André Leroy, Angers.—*Supplément au Catalogue de 1868. Prices of Fruit Trees and Ornamental Trees and Shrubs, 1870-71.*

J. Standish & Co., Royal Nursery, Ascot, Berks.—*Catalogue of New and Rare Plants, Hardy Trees, Shrubs, Conifers, &c.*

Charles Turner, Royal Nurseries, Slough.—*Catalogue of Roses, Fruit Trees, Conifers, &c.*

F. & A. Dickson & Sons, 106, Eastgate Street, and Upton Nurseries, Chester.—*Descriptive Catalogue of Roses and Hollyhocks.*

TO CORRESPONDENTS.

* * * We request that no one will write privately to any of the correspondents of the "Journal of Horticulture, Cottage Gardener, and Country Gentleman." By doing so they are subjected to unjustifiable trouble and expense. All communications should therefore be addressed solely to *The Editors of the Journal of Horticulture, &c.*, 171, Fleet Street, London, E.C.

We also request that correspondents will not mix up on the same sheet questions relating to Gardening and those on Poultry and Bee subjects, if they expect to get them answered promptly and conveniently, but write them on separate communications. Also never to send more than two or three questions at once.

BOOKS (*An Amateur, Newcastle*).—"The Greenhouse," by C. McIntosh, and "In-door Gardening," by Keane. The latter you can have post-free from our office if you enclose twenty postage stamps with your address. (*Bayard*).—You probably mean "Paxton's Botanical Dictionary," a single volume, price 25s.

CHRYSANTHEMUM SHOWS (*J. P.*).—There will be some near London, and will be advertised.

SEEDLING PANSIÉS (*G. McD.*).—The blooms were all withered. We cannot prophesy what would be the result of advertising your Melon seed.

PAMPAS GRASS (*G. S.*).—A panicle of a female plant was enclosed by you. It is the usual colour. It is the male plant that bears the plumes.

RAINFALL (*J. B.*).—The differences are not at all extraordinary. We have seen rain falling on one side of a road whilst there was none falling on the other side.

MOVING ROSES (*J. H.*).—You may remove the Roses budded this year, but it is a good plan to let them have a year's growth before removal to their final quarters. If removed now they will not start strongly in the spring, but care being taken in moving, there is not after all any great difference.

SOWING THE SEEDS OF EVERGREENS (*Idem*).—The Laurel berries should be kept in sand, and in February be sown in sandy soil in a warm yet open situation. The Rhododendron seed should be sown in pans or boxes, or in a cold frame in March, in a compost of sandy peat, with a free admixture of silver sand. Keep the soil moist, and admit air freely, and when the plants appear draw down the lights. The present is a good time to plant Virginia Creeper and Clematis.

ANNUALS TO FLOWER IN A GREENHOUSE IN SPRING (*E. B.*).—Besides *Nemophila* and *Mignone*, you may sow now *Alyssum maritimum*, *Asperula azurea setosa*, *Calandrinia umbellata*, *Campanula Lorei*, *Clarkia pulchella* and *C. pulchella alba*, *Collinsia verna*, *C. bicolor*, *C. candidissima*, *Eucharidium grandiflorum*, *Gilia tricolor* varieties, *Gypsophila marialis*, *G. elegans*, *Kaulfussia amelloides*, *Leptostemon aureus*, *L. androsacens*, and var. *albus*, *Lupinus annuus*, *Nolana atriplicifolia*, *Platystemon scifloricus*, *Silene ruberrima*, *Viscaria oculata*, *Whitlavia grandiflora*, and its white variety.

WINTERING CANNAS (*Idem*).—Keep them in any place free from frost from November to March, and dry; then repot them, place them in a hotbed so as to start them into growth, and harden them well off before planting out.

CHEAP HOUSE FOR TEA ROSES (*Idem*).—It would be best with the front glass, but you need not have the front more than from 2 feet 6 inches to 3 feet high, and then boards would answer, but there is so little difference in the price that we should prefer glass. We would have two boards' height of wood, or two boards 11 inches wide, and one of them hinged for ventilation; then 2 feet 6 inches of glass, with the ends of glass down to the wood part. You may provide for top ventilation by a board hinged at top, so as to open the full length of the house. Have you no wall against which to place it, so as to save the expense of the back? Wood would no doubt answer.

ROSES PRUNING, &c. (*De la Bourbon*).—Advice on the matter of pruning is no doubt often conflicting, as much depends whether Roses are wanted for exhibition purposes, or for ordinary garden decoration, or, again, for cutting for the house. If Roses are wanted for exhibition, the first blooms from budded Briars, or the second year's from vigorous growth on the Manetti stock, are the best; but for general garden purposes we recommend all old weakly wood to be cut clean off, and strong shoots to be well shortened—the laterals on strong shoots to four or five eyes, and on weaker shoots to two or three eyes. When Roses are grown on Manetti stocks it is a good thing to cut right away to the base all wood that is more than two years old, so as to encourage the plant to push fresh shoots from the base. The strongest shoots from the base of the current year's growth generally do not push any laterals the first year, but flower at the ends in the autumn. These ought not to be shortened too much at first, but may be cut about the height that the rest of the bush is left after pruning. They will give very fine blooms next summer from the upper eyes that are left, and push lower down in autumn to furnish strong wood for another year. We should advise you in the case of your Roses on the Manetti stock, planted out of pots in August last, to prune the leading shoots to about 15 or 18 inches, according to their strength, and to shorten the laterals to three eyes. It is difficult to give advice without seeing the plants, and it is necessary to study the habits of the different varieties of Roses, as some require close pruning, while others will not stand it. Such sorts, for instance, as *Blairii*, *Cloth of Gold*, *Solfaterre*, and *Mar-chal Niel* only require to have their shoots thinned, and the very strong shoots only slightly shortened. These remarks do not apply to standards, which must be pruned to keep a symmetrical head, and only wood of medium growth is to be encouraged; but, as a general rule, when quality of bloom rather than quantity is required, use the knife freely, and do not let Rose trees be overcrowded with old shoots. A little careful observation will show amateurs that Roses produced on the side shoots of stems only one or two years old from the base are finer than those on older wood; and in our opinion, when cutting Roses for table decoration, a dozen good

Roses are worth two dozen inferior, and no poor specimen ought ever to be allowed in a vase of flowers for table decoration.

MARANTA LEAVES BROWNEO (*Vitis*).—We think the browning of the leaves is due to a deficiency of heat, accompanied by too much moisture. Give a temperature of 60° at night from now to March, from 65° to 70° by day, and do not overwater, yet see that the soil is moist and the drainage good. The compost is good, but we would use one part loam, two parts sandy fibrous peat, and one part leaf soil, with one part of silver sand and charcoal in equal proportions. We think the leaves are those of *Maranta lineata* rosea, but we cannot tell from such miserable specimens. The leaves are not diseased.

STORING PEARS (*A Constant Subscriber*).—The fruit keeps best in a moderately dry room, and one cool, yet safe from frost. We should consider a cellar not wet a better place than an attic. Remove the Pears to a light room with a temperature of about 45° a few days before they are required for table. They ought not to be removed from the cellar until they begin to ripen.

SCREEN TO HIDE A WALL (*A Working Man*).—Why not cover the wall? *Pyraeantha* is very pretty, and *Cotoneaster microphylla* will hide every part. If you cannot train against the wall, then we would advise *Berberis Darwinii*, which will bear trimming well, and is very ornamental early in spring when in flower; *Laurustians* is also good; but if they are not close enough you may plant Yew. You may cut it as hard as you like, and make, in fact, a close green wall of it. Now is the time to plant. Allow 3 feet between the plants of *Cotoneaster*, *Laurustians*, and Yew, but the *Berberis* should be 2 feet apart. Manure the ground well; it is the way to get the screen up quickly.

SEEDS SOWING (*N. C. H.*).—You may succeed with all, except, perhaps the *Erythrina* and *Cocculus*, which should be sown in March and placed in a hotbed. The others should be sown at the same time and placed in a cold frame. Pans will be most suitable; they should be well drained, and filled with a compost of two parts fibrous loam, and one part each of sandy peat, leaf soil, and silver sand. Cover every kind of seed with a depth of soil equal to its diameter. Keep close until the seedlings appear, then give air, but not in excessive quantity, and water so as to keep the soil moist. The plants from the seeds sown in the cold frame will need potting-off in October, and should be continued in a frame a year longer, and two years after sowing may be planted out. Those sown in heat should be potted-off when large enough to handle and grown on. They will require protection from frost in winter.

AGAPANTHUS TREATMENT (*E. R. Yorks.*).—We think your hnh is the African Lily, *Agapanthus umbellatus*; but we are at a loss to advise you as to its treatment, as you do not state whether you grow it in or out of doors. If you have it out of doors it will only make a few leaves and not flower. To succeed well it requires a greenhouse, and a compost of two parts light fibrous loam and one part sandy peat, with a free admixture of sharp sand. In winter it should only have enough water to keep the leaves fresh, but when it begins to grow give more, and when it is growing freely copious supplies are required. From May to frost it may be placed out of doors. A rather small pot for the size of the plant is necessary. We may be mistaken in the plant. We know of none by the name you give.

ECHITES SPLENDENS NOT FLOWERING (*A. M. C.*).—The plant is probably kept in too dark a house. Encourage it in spring with a brisk heat and moist atmosphere, potting it when it begins to make fresh growth. Be careful not to overwater, and in winter keep it dry. *Enclaris amazonica* and *E. grandiflora* are identical. The writer of the article about which you inquire is not the gentleman you name.

CABBAGE PLANTING (*An Old Subscriber*).—The plants sown July 30th, and pricked out September 13th, may now be planted out—that is, the strongest of them, in a sheltered situation, deferring the principal planting out until early in March.

FRAMING CAMELLIA PLANTS (*Idem*).—It would be well to remove some from the outside border to a frame, and we advise it to be done forthwith, so that they may have time to root before severe weather set in. There is no advantage in twice pricking off, first in a border and in a fortnight to a frame.

PLANTING ARUMS IN A POND (*Idem*).—None of the Arums as far as we know are aquatic; they should have a sandy soil, with freedom from stagnant water; hence they should not be planted in a pond. If by Arum you mean *Calla* or *Richardia* *athiopica* it should be planted in a foot deep of water.

CAMELLIA BUDS THINNING (*Bismark*).—Three or four buds on each stalk are too many. Reduce them to two buds each. What is it you wish for hints on? We might give you many hints, and still not meet your case. A few good sorts are *Alba pleca*, *Chandleri elegans*, *Economia*, *Fimbriata*, *La Pace*, *Leeana superba*, *Monarch*, *Leopold I.*, *Mrs. Cope*, *Napoleon III.*, *Rafia*, *Rubens*, *Stoyn*, *Valtearedo*, and *Wilderi*.

FAIRY RINGS (*S. Amherst*).—Your fairy rings will continue to get wider and wider every year, as you say. We know of no better means for destroying the fungus without hurting the grass, than sowing the rings thickly with quicklime and a little sulphur. We fear, however, you would have to repeat the operation several times, unless you broke the surface and mixed the lime at once with the fungus spawn. Lime will destroy them if persevered with, and so would sulphur, though more expensive.

KEEPING WALNUTS (*A Reader*).—Perhaps there is no better mode for keeping Walnuts in winter than packing them in dry sand, and changing the sand frequently. The chief objection to this mode is that the nuts want much brushing to get all the sand away, as otherwise the shells would feel gritty. If the sand is dry, air may be excluded by a thin layer of turf. Any neat little shrubs, as *Aucubas*, *Hollies*, and *Cypresses*, will do for a flower garden when the flowering plants are removed, and so would all kinds of *Wallflowers*, *Daisies*, *Pansies*, and early-flowering bulbs.

STORING DAHLIA TUBERS (*A New Beginner*).—There is no better plan of keeping the tubers in winter than to take them up after the first frost, lay them in a shed to dry, and then to store them in dry sand, where they will be safe from frost. We do not see in what way you can improve the size of the flowers, except by thinning the buds, so that the support may be given to a few instead of the many which you probably leave. It is also a good plan to thin out the weak shoots.

TULIP TREE SEEDS (*F.*).—They do not generally ripen in this country, but in so unusually hot and dry season like the past they may have done

so, and perhaps may germinate. We would keep them in dry sand, and early in March sow them in pans of light rich loam placed in a hotbed, to be removed, when the seedlings appear, to a cold frame. Then harden off.

CZAR VIOLET CULTURE (*Mrs. Y. B. A. Z.*).—The best plan is to grow it in cold frames. In May take off the rooted runners, and plant them in a border of good, rich, light loam, and, if the situation is protected from the sun at midday for a few hours, all the better. They should be planted a foot from row to row, and 9 inches apart in the rows. Water well in dry weather, and at the close of September take them up with balls, and plant them in a frame in a warm sunny situation. A hotbed frame used for Cucumbers or Melons will answer very well. Do not put on the lights, and give air in fine weather, using the lights only in cold frosty weather. When very wet keep on the lights, but admit air by tilting them. In very severe weather protect with a covering of mats, straw, or other material.

DEODAR SHOWING CONES (*A Subscriber*).—It is unusual for the Deodar at any age or size to produce cones in this country. There have been, however, a few instances, but in very few instances do the seeds attain perfection. It is probable that the plant producing cones, though only ten years planted, may be a scion of a tree quite as aged as your other trees thirty or more years old. The Deodar is for the most part raised by grafting, and also by cuttings, both cuttings and grafts being taken from parts of trees from seed that may have attained maturity; and we think your younger tree is not a seedling, but a grafted tree, or has been a cutting, both of which modes of propagation tend to earlier cone-bearing. It is known that propagating by grafting, budding, cuttings, and layers has a tendency to promote early flowering, and consequently fruit-production.

THINNING STRAWBERRY CROWNS (*Agnes*).—This should be done in spring when the buds are so forward that it can be seen which are likely to produce fruit. Those in the centre are most likely to need thinning, in order to admit light and air. Three-year-old plants will hardly need thinning as yet, unless the runners have been allowed to have their own way, in which case the plants will require thinning to admit light and air to those left for fruiting. Thinning may be done now or in March.

TREES FOR ARBOUR (*City Garden*).—You do not say whether your arbour is formed of trellis or latticework, and you wish to cover it. Irish Ivy is good, and so is Clematis Vitalba, also C. frankfurtensis. If you wish for an arbour solely of trees, then Hornbeam answers well for the sides, with a Weeping Ash to form a canopy overhead. The Hornbeam should be planted as a hedge, and kept as such with the required openings.

CHRYSANTHEMUMS MILDEWED (*E. S. C.*).—To keep them from mildew, give them abundance of air and as much light as practicable, not standing the plants so closely together as to be crowded. If mildew appear, paint the hot-water pipes with flowers of sulphur, or dust the parts affected, using a coarse muslin bag.

WINTERING LILIUM AURATUM (*Idem*).—Pot them as soon after this as you can, removing all the old soil that comes away freely from the roots. The stalk, when it is quite yellow, should be cut off close to the surface. You may give them 9-inch pots. Pot so that a rich top-dressing can be given in spring. Water gently after potting, but do not keep more than moist over the winter. If safe from frost, the cooler they are kept the better.

TRANSPLANTING SHRUBS (*L. J. P.*).—Now is the best time to move Laurustinus and Portugal Laurels; but as your trees are old we should have preferred moving them at the end of September had the ground been moist then. Indeed, even now, the ground, though we have had some heavy rains, is much too dry for general planting purposes. In moving old trees it is well to take out a trench round each this autumn, cutting off all roots encountered in digging the trench, and going quite as deep as the roots. The trench should then be filled in, and the shrubs left until that time twelve-month, when the trench may be reopened and the plants removed, preserving with the roots as much soil as possible, but taking away all the old soil you can without injuring them. The distance from the stem will be dependant on the size of the shrubs, but in no case need it exceed 3 feet. If the shrubs are much overgrown and straggling, the growths should be well cut in the spring after planting at the beginning of April. Success in planting chiefly depends on preserving as many of the fibres as possible with some soil adhering to them. A good watering ought to follow the removal, so as to settle the soil about the roots.

SHRUBS FOR PLANTING UNDER THE SHADE OF ELM AND BEECH TREES (*A Constant Reader and Admirer*).—Of all the shrubs we have tried under large trees none will succeed so well as the Aucuba, Berberis Darwinii, Berberis dnica, and tree Box are also good. Butcher's Broom (*Ruscus aculeatus*), Alexandrian Laurel (*Ruscus racemosus*), Skimmia japonica, Spurge Laurel, Privet, and Snowberry all do well, and nothing succeeds better than the Ives and Periwinkles. The common Laurel, Holly, and Yew succeed tolerably well, but not so well as the first-named. Dogwood and the Guelder Rose in moist soil are fine; and Berberis Aquifolium, Cotoneaster microphylla, and the common Berberry we have seen in good condition under trees.

MADRESFIELD COURT GRAPE (*Amateur*).—We are not aware if it has ever been tried in a vinery without fire heat, and we rather think it would not succeed well under such conditions; but from what we have seen of it we have little doubt it would do very well in such a place if it had a fortnight or three weeks of heat at the blooming and setting season. The mulching fruit trees with tan during winter is, no doubt, beneficial. We are sorry we cannot say where Amateur Strawberry is to be obtained.

VINES ON A WALL (*E. M. A.*).—There can be no question that the Grapes would be more secure if covered with glass, but we can scarcely advise you as to details, as we do not know how far the pathway is from the wall. If that is only 3 or 4 feet from the wall, the upright glass would be best, with a hipped roof at top. If you could come out 5 or 6 feet, then you might have a sloping fixed roof. The cheapest way to do this would be to have stout posts, a sill or wall plate within 10 inches of the ground, so that a board of that width would be the ventilator, and to use rafter sash-bars for glass 10 inches wide, or wider if deemed advisable. The top end of the rafters might be fixed to the wall, or to a ridge board 9 inches from it, and that would give the means for top ventilation. If you gave us more particulars we might afford you more hints, but you will see good examples in the neighbouring nursery.

POT VINES (*M.*).—On receiving the Vines you will find in what sort of pots they have been growing, and if they are in 13-inch pots, all you have to do is to see that the drainage is good; if it is not efficient, make it

so. Then remove the surface soil as far as possible, replacing it with fresh loam from decayed turf top parts, and one part each of fresh horse droppings and of half-inch bones, with half a part each of calcined oyster shells and of charcoal broken small. This makes a first-rate top-dressing for pot Vines, or, indeed, for those in borders. If the Vines are in 9 or 11-inch pots, pot at once in 13-inch pots, and do not disturb the ball; merely loosen its sides. The next thing you will have to do is to prune them, then place them in a position where protection can be given from frost, or they may be set in the greenhouse if its temperature from fire heat does not exceed 40°. The selection of Vines—viz., Black Hamburgh, White Frontignan, and Victoria or Pope's Hamburgh (Frankenthal), is good. The pots should stand on a stage, or on the soil if they can have sufficient light. They need not be further apart than 3 feet. To start the Vines in a greenhouse we think absurd, for if you give more heat than is required for the plants these will suffer. However, you may start the Vines when you like, beginning with 40° for a fortnight, then increasing the heat to 45°, adding 5° fortnightly until you attain a temperature of 60° at night. By day the night temperature should be exceeded by 5° on dull days, 10° on those cloudy but with clear intervals, and 15° or 20° on fine days.

SALT FOR ASPARAGUS BEDS (*A. B., Hamburgh*).—The salt is that used for cooking. You need not be surprised at this, for Asparagus is a native of the seashore; and, besides, common salt, if used judiciously, is a good manure for many crops.

HEATING A CONSERVATORY (*Erin-go-Bragh*).—We can hardly see how we can advise you, as any pipe or chimney is so objectionable for your small house, and the want of the power to heat it would render it next to impossible to grow anything except hardy evergreens in winter, to be followed by Wallflowers, Violets, and bulbs in spring. Other plants more tender you could only keep by leaving the doors of the drawing-room and dining-room open at night. We do not perceive how the iron stove in the entrance hall could do you any good, as it would be impossible to do as you propose—heat a boiler beneath it, and take pipes under the dining-room floor. If you had any place where you could fix a boiler lower than the floor, so as to take pipes underneath the latter, there would be no difficulty, if you had a chimney near. In your case, as you speak of gas stoves and boilers, we would dispense with the latter, but have one or two small gas stoves with flat tops, to receive a basin of water, and use the largest size of arand burners. These consume the gas most thoroughly; but even then, to be perfectly safe, it would be well to have a very small pipe from one-eighth to one-fourth of an inch in diameter inside, to go from the side of the stove near the top into the open air, the end being turned down a little. This would carry off what little gas was not thoroughly consumed, and even one good burner throws out a great heat.

BOILER (*Seraphina*).—All things considered, a conical boiler fed from the top might suit you best, but, as stated lately, we must decline to say which is the very best. We are confident we could make any of the boilers advertised in these pages the best, according as we resolved on doing so. For all quick work, such as getting up sudden heat to meet sudden frost, the smaller the quantity of water in the boiler in proportion to the surface exposed to the fire, the sooner will the pipes be heated.

INCORUSTATION IN HOT-WATER PIPES (*G. B. G.*).—The best preventive is to put 2 or 3 ozs. of muriate of ammonia (sal ammoniac) in the boiler.

DESTROYING SCALE (*A. Y.*).—You do not say what kind of scale it is you wish to free your plants of, but we presume it is white scale from your alluding to Acacias. The vapour of turpentine will destroy not only all insect life, but cause the destruction of every fresh leaf. We remember a house planted with Vines being painted whilst the Vines were in active growth. Turpentine was used in the paint, and, the house being closed at night, the leaves of the Vines an hour afterwards were drooping as if they were suffering for want of water, but, the ventilators being opened, the leaves recovered their freshness. Some of the younger leaves had the edges browned in the morning. It is not safe to use it for the destruction of insect life where there are plants in growth. The best means of applying it is along with 2 ozs. of soft soap dissolved in a gallon of water used at a temperature of 100°. Allow about six drops of turpentine to the gallon. Syringe forcibly the plants laid on their sides, so that the solution may not wet the soil, and the plants being turned round so that every part may be wetted. This will in most cases free the plants of the white scale.

PLANTING VINE (*R. C. Sideo*).—No season for planting could be better than the present. We think either the Royal Muscadine or the Buckland Sweetwater much more worthy white Grapes for culture in a vinery than the common Sweetwater.

NAMES OF FRUIT (*H. M. P.*).—Your Pear is an American sort called Orange Mandarin. (*H. B.*).—We paid 10d. as carriage for your box. On receiving ten postage stamps we will examine the fruit. (*H. G. M.*).—2, Birmingham;—Stone Pippin; 3, Welbeck Bergamot; 4, Bergamotte Buffo. (*John Garland*).—5, Hughes's Golden Pippin; 14, Ross Nonpareil. All the other Apples are evidently local varieties, with which the Devonshire orchards and gardens abound. Pears: 1, Urbainette; 2, not Knight's Monarch. (*A. O. K.*).—2, Doyenne du Conice. (*A. A.*).—Apples: 1 and 5, Beauty of Kent; 3, Alfriston; 4, Golden Noble; 6, Mauden's Blush. Pears: 1, Bergamotte Cadette; 2, Red Doyenne. (*H. F. Hart*).—The large Apples are Gloria Mundi. We shall refer about Eckinville and let you know. (*Miss Johnson*).—2, Beurre d'Armenie; 3, Soldat Esperon; 4, Conite de Lam; 5, Fasse Colmar; 6, Rousselet Thon; 7, Knight's Monarch. (*J., Birmingham*).—1, Beurre Diel; 2, White Doyenne; 3, Glon Morcean. The Apples are unknown. (*H. F. C.*).—1, Kentish Codlin; 2, Cambridge Pippin; 4, Devonshire Buckland; 5, Lewis's Incomparable. (*James Brown*).—2, Passe Colmar; 3, Napoleon; 4, Josephine de Malines; 5, Louise de Prusse; 6, Ne plus Meuris; 7, Beurre d'Armenie; 8, Brown Beurre. (*Amateur*).—Apples: 1, Reinette Blanche d'Espagne; 2, Cobham; 4, Bedfordshire Foundling. Pears: 1, Crasanne; 2, Beurre d'Ormeau; 4, Forelle; 5, Auguste Kover. (*Mr. Lombard*).—Your Pear is certainly not Marie Louise d'Uccle, but appears to be a remarkably fine specimen of Doyenne du Conice. (*A Subscriber*).—7, Bergamotte Cadette; 17, Old Colmar; 18, Ne plus Meuris; 13, Pomme Poire; 16, Napoleon; 2, Sturmer Pippin.

NAMES OF PLANTS (*Adams*).—We cannot name plants from their leaves only, we must have flowers also. (*A. M'Callum*).—Arctotis repens. Mr. Beaton called it "Frosted Silver Plant," and used it as an edging.

POULTRY, BEE, AND PIGEON CHRONICLE.

PRIZES, AWARDS, AND REFORMS IN POULTRY SHOWS.

The most promising symptom I can see of genuine progress and improvement in the poultry fancy is the greater amount of active interest in shows and other matters connected therewith. Fanciers are not content now to acquiesce quietly in whatever a committee or a judge may choose to lay down for them; awards get discussed and abuses get examined. There never fails to be something well worth the talking about; and some remarks in the last number or two of "our Journal" suggest to me several points in which I think a little change would be very desirable, while it could offend the prejudices of none.

For instance, in speaking of the Birmingham Malay classes, Mr. Brooke justly remarks on the great difference between the value of the first and second prizes; but the criticism has, I think, a much wider application. Time was when one really first-rate pen in a class was perhaps the ordinary rule, but it is not so now by any means. In all the great shows of the year, and in most even of the second rank, the greater number and the far sounder knowledge of the exhibitors have made the competition very close and severe. Again and again have judges no small difficulty in deciding which shall be first, second, and third; and as often have I noticed cases in which any breeder would give as much for the one pen as the other; or as the Irishman said, one pen "was as good as another, and a great deal better." The question arises, Should not the value of the prizes show less money difference? It is not a question of justice, for no injustice is really done; it is a matter simply of expediency and popularity. The honour of being first would remain the same, but I have reason to believe that an increase in second and third prizes, even at the expense of the first, would tempt more exhibitors to many a show.

As I have mentioned the Malay class, let me state the pleasure with which I hear from Mr. Brooke that I am again to see some real big birds again, and that some fresh breeders have started them. I think, however, that "Y. B. A. Z." is wrong in attributing the deterioration in the breed which he admits to having "so little encouragement." Is it not rather the other way, as I endeavoured to make clear? My impression is that no breeder ever lost ground from want of prizes, but rather, as breeds have lost popularity, committees have been forced to decrease prizes in sheer self-defence. To take solitary examples is not safe. I have often noticed an almost empty class one year fully filled the next, and *vice versa*; but the committee of no show can or will go on giving prizes to any variety which it is found repeatedly does not pay by its entries; whilst, on the other hand, every leading variety but Dorkings, Spanish, and Hamburgs has had no difficulty in fighting its way up in spite of "no encouragement." I would not have named this point again, but that I think its candid remembrance would save much sore feeling; not to "Y. B. A. Z." certainly, who has never shown any, but to some other occasional complainants, who seem to think that their favourite breeds have a kind of abstract right to as much and as many prizes as any other. Let them make their pet breed popular, and committees will give them all the "encouragement" they desire; and meanwhile they are only fighting the same obstacles which Brahmas, Hondans, Crève-Cœurs, and others have successfully vanquished before them.

Another point, however, seems to me to be now of importance, and that is, that the published awards at shows should have some regular, recognised, and standard value. I am not speaking of the value given to them by the known ability of the judge, but something by which a simple reader of the award list should be able to form a tolerably correct notion of the real value of the pens and the character of the competition. Nothing could be more easy, while at the same time nothing, it seems to me, can at present be more important. Many still speak of the poultry fancy as a mere hobby, while in point of fact it has become a very serious business, carried on by many of the highest, fairest, and most honourable in the land; and the mere amount of money invested in it, if calculated, would make every reader of this Journal stare. Such interests as are concerned ought by no means to be laughed at or left to chance, as they often are now; whilst a systematic theory of awards

would in itself and by itself go very far to supply the place of the more extended reports only too justly longed for by "SHROPSHIRE RECTOR." At many shows a commendation is really worth more than a prize at others, yet there is at present no means of distinguishing between one and the other; whilst only the other day, in a judge's report, it was stated rightly that a particular class was all through "of extraordinary merit," whilst, besides the two prizes, the judge only awarded a simple commendation to one solitary pen!

If I be asked how this could be amended, what I would propose would be that the award of "very highly commended" should be given to all pens, and to those only, which in any ordinary show would be thought worthy of a place in the prize list. I say to all, because the number of such awards would always be then a guide to the quality of the class. If, besides this, the pens "highly commended" were arranged in their order of merit, I think all that is necessary would be done, and the list of awards alone would then present a real index for the use of absent breeders, which it certainly does not now. In the case of those catalogues which, like the Bristol, give the awards in the margin instead of in a separate list, the order of the pens highly commended could be shown by numbers, and in the mere commendations I think order of merit would be hardly necessary. Nothing could be more easy, and I venture to think hardly anything would be of more use to the body of poultry fanciers. I would much like to know the views of Mr. Hewitt, than whom no one is better acquainted with the important interests involved, upon this subject, and I had meant to ask them privately before mentioning it in these columns, but the remark of "SHROPSHIRE RECTOR" respecting the want of information leads me to broach the question now.

Regarding trimming, which two correspondents have recently mentioned, I think "ALQUIS" has either not seen or has forgotten Mr. Hewitt's suggestion as to a punishment. I have not yet lost my interest in the matter, but I always have and always shall object to any rule precluding an offender from showing again, as not being analogous to any law either Divine or human. I think Mr. Hewitt's suggested penalty severe enough. But in one thing "ALQUIS" is quite right; the whole matter now rests with committees. No one can say now that judges will not act. Mr. Hewitt has formally asked for more power, and expressed his willingness to accept all the responsibility; he will pass the judgment if the "civil power," in the shape of committees, will enforce the penalty. I regret to have to add that I have been forced to the conclusion that a great many committees have no desire the abuse should be discouraged, for the simple reason that many of themselves or their friends are too deeply compromised. I quite understand, and was much amused at, the delicate allusion of "A DISGUSTED EXHIBITOR" to the "pickled" feathers; and in answer to his inquiry as to Birmingham, I beg to say that the inaction of the Council is not for want of reminder. Many readers will remember that a while ago I spent much, both of time and money, upon this matter; and a year since I sent them a copy of the protest against the practice, signed by over fifty of the very best names in the fancy, with an earnest appeal, if they could not see their way to anything further, that they would simply state that their judges would be "specially requested" to disqualify all fraudulently trimmed birds. I do not know on what ground any committee could refuse at least as much as that; but the Birmingham folks did, and the annual spectacle which followed as usual disgusted not only your complaining correspondent, but—L. WRIGHT.

POULTRY SHOWS,

THEIR MANAGEMENT AND REPORTS.

THE new county rector of "our Journal," and may their name be legion, I mean "SHROPSHIRE RECTOR," has, I fancy, had but little acquaintance with poultry shows, or he would have found that the great number of committees do not at all consider that "every exhibitor whose entries amount to, say, 10s., is entitled to a ticket of admission." I cannot answer for the northern shows so much; but in the south, with the exception of Bristol and Clifton, and Lord Tredegar's Show at Newport, there is no free entry to exhibitors. In the north, I fancy, they are more liberal; certainly both at Middleton and Roshdale exhibitors were sent tickets, at least I was, and this is as it should be. I feel confident the omission is an injury to a show. The fact of receiving such a ticket elicits additional sympathy in the success of the show, and often decides a doubtful exhibitor on visiting it. I have often advocated the

adoption in your pages, but committees, as a friend of mine is fond of remarking, "don't seem to see it."

The matter of the catalogue also, is a serious annoyance to exhibitors. Certainly exhibitors are the back bone of an exhibition: this, I suppose, is granted. True, many obtain their *quid pro quo*, but many do not. I apprehend that in a good show the latter class form the majority, and surely it would be wisdom on the part of committees to show this little courtesy, by sending one to those to whom, after all, they are indebted for any exhibition at all. Then, again, it should be the first duty of the Secretary, after the publication of the catalogue, to dispatch them by *first post* to distant exhibitors. Before now I have ordered my catalogue, have left home on the second day after its non-arrival by post, have arrived at the exhibition, and found that all the catalogues were sold on the first day; mine, although previously ordered, sharing the same fate! Some committees—and here our grandmother, Birmingham, sets the example—wipe their hands of all catalogue business. In this case, it appears to me the duty to sell this part of the transaction with the understanding that each exhibitor shall be furnished with a copy as early as possible.—Y. B. A. Z.

WEIGHT OF FOWLS INFLUENCING JUDGES AT POULTRY SHOWS.

I HAVE often been asked why I did not exhibit at Birmingham? My answer has invariably been, if I did with any chance of success, I should for ever spoil my birds for breeding. I exhibit nothing but Dorkings, still the same objection applies to all the large breeds. Why are the exhibitors of the large breeds compelled to fatten their birds to such an extent as to utterly ruin the birds for breeding? Surely the frame ought to be the criterion, not the weight. If you get the large frame, weight is merely a question of feeding. True, you cannot get a large frame without good feeding, but after you have the frame why should you be compelled to ruin your birds so as to put on extraordinary weight? This, to me, is one very great objection to the Birmingham Show. Let frame, not weight, carry the honours, and then both the Show itself and the public generally, as well as those who delight in poultry, will benefit by the change.

Although no novice, let me from sad experience warn intending purchasers of the large breeds against buying prize birds at Birmingham, unless they can satisfy themselves, which I have never been able to do, that the birds are not so fat as to be utterly useless for breeding. Mr. Wright's excellent letter has led me to make these few remarks, in the hope that some one of influence in the poultry world will take up the cudgels in favour of frame *versus* weight.—THOS. E. KELL, *Wetherby*.

[We are in a position to say, the Dorking prizes at Birmingham have never been awarded by weight. The judges would have wilfully deviated from their instructions had they done so, and, we believe we may add, from their own convictions. Those who believe such a report believe it on hearsay, and hearsay is a bad authority.—Eds.]

SELECTING FOWLS FOR EXHIBITION.

[Our Canadian brethren are going ahead; we extract this from the *Canadian Poultry Chronicle*.]

THE first care of an exhibitor should be the proper matching in colour of his birds for the show pen. The want of attention to this point causes the frequent loss of a first prize to many otherwise well-deserving pairs of fowls. They may be all that the most fastidious amateur can desire, if taken singly and examined by the scale of points, but yet matched as they frequently are, judges are compelled to pass them by without recognition, much to the chagrin and disappointment of the exhibitor, who, in ignorance of the real cause, not unfrequently attributes to them incapacity, or perhaps something worse. Exhibitors should never forget that birds not matching in the show pen are invariably disqualified by all judges who know anything of the principles laid down for their guidance in such matters, no matter how perfect they may be in all the other points. Size, too, beauty of plumage, markings, symmetry, condition, &c., ought also, all in their turn, to be carefully considered, and each point of the bird carefully scrutinised before being selected for the show pen.

Poultry-breeders are indebted to the London (England)

Poultry Club for the "Standard of Excellence" for the guidance of judges in making their awards, a knowledge of which is equally essential to the exhibitor as the judge. Without it he is unable to make his selections with any degree of certainty of obtaining a prize; with it, he is sure of his birds not being disqualified, even supposing he may not be so successful in the much-sought-for honour of prizetaking.

The "Standard" places a separate value in numbers on each point of excellence, which, when summed up, make a total of fifteen for each bird. The values attached to these points are not alike in all breeds of fowls. In some they are calculated on a different scale to that of others, a thorough knowledge of which makes the successful exhibitor and good judge.

In the Cochin breed, the varieties known as Buff, Lemon, Silver Buff, Silver Cinnamon, and Cinnamon, size and colour are highly estimated; to these two points the value of seven is assigned out of a total of fifteen, the former having three, and the latter four given to it; while to the six remaining points—viz., head and comb, carriage of wings, legs, fluff, general symmetry, and condition, a value of eight is attached. In the Grouse and Partridge varieties of this breed, instead of a general value of four being given to colour, it is divided into sub-values of two each, on account of the more specific markings of the feathers of these birds, and which exhibitors would do well to note. The value of points in White and Black Cochins are the same as in the Buff and Cinnamon, the difference in colour only considered, and the same remark holds good as to Dark or Pencilled Brahmas, and Light Brahmas, as to the values of points.

To breed to size as well as feather has long been the chief feature of the Dorking breeders. That this should be so is not to be wondered at, seeing the prominent place assigned to it in England as a table fowl. Special value is therefore given to size in the Dorking class beyond that of any other class or breed of fowls, except to La Flèche, Turkeys, and one variety of Ducks. In the Coloured Dorking size counts five, symmetry four; while head and comb; legs, feet, and toes; and condition, count but two each.

To the White variety a point of excellence is given not recognised in the Coloured—purity of plumage, on which a numerical value of two is fixed. To make up this a deduction of one is made from each of the two points size and symmetry, reducing their value to four and three respectively, instead of five and four as in the Coloured.

A still further deduction from size is made in the Silver-Grey variety, and added to colour; thus we have in the Silver-Greys the points size, colour, and symmetry, all ranked of the same numerical value—three, while the other three points rank as in the Coloured, two each.

The Spanish breed of fowls has only one recognised variety, although there are several sub-varieties, known as the Minorca, White, Andalusian, and Anconas. Face, ear-lobe, and symmetry are of equal rank, each point counting three; comb, condition of plumage, and purity of white face and ear-lobe, count two each. Of the six points to which the numerical value of fifteen is assigned, the face and ear-lobe count eight—over one-half. It will be seen, therefore, of how much importance it is to select fowls of this breed with face and ear-lobe free from those red blotches which are so frequently met with in birds of this variety.

The points of the numerous varieties of Game Fowls, usually known as the Black-breasted, Brown, and Ginger Reds, Yellow, and Silver Duckwing, Birchen Yellow, Pile, White, and Black, are seven in number. Colour of plumage ranks the highest, and has a value of three given to it; while shape of head and neck; body and wings; tail; thighs, legs, and toes; symmetry, handling, condition, and hardness of plumage, have each a numerical value of two.

Of the many breeds of fowls which are to be met with at an exhibition, there is perhaps none which attracts the attention of the visitor more than those of the Hamburg class. The beautiful markings of the feathers of the different varieties known as the Gold and Silver-pencilled, Gold and Silver-spangled, and Black Hamburgs, call forth his admiration, and ought to be an increased incentive to exhibitors in the exercise of great care in the selection and breeding of these fowls. In the Gold and Silver-pencilled Hamburgs there are in cock birds six points of excellence, three of which—comb; colour of plumage, except tail, sickle feathers, and tail coverts; and colour of tail, sickle feathers, and tail coverts—count each three; the deaf ear, symmetry, and condition numbering two each. The hens have a similar number of points, but vary in name and numerical value—comb, deaf ear, symmetry, and condition numbering two each; while purity in colour of head and neck;

purity of ground colour, and accurate and distinct pencilling, in every part, except head and neck—count three and four respectively. The difference in markings between the Spangled and Pencilled varieties call for a separate classification of points. In the Gold and Silver-spangled Hamburgs, then, the comb, deaf ear, breast, under parts of body and thighs, wings and bars, symmetry, and condition, of the cocks should each number two, and colours and marking of head, hackle, back, saddle and tail three; whilst in the hen, combs, deaf ear, bars, symmetry, and condition count two. Neck most distinctly and evenly striped, one. Remainder of plumage (except tail in Golden) clearness of ground colour, evenness and distinctness of spangling, with rich, large, round spangles, four. In the Black Hamburgs, plumage and shape each count four; comb, head, and face, three; deaf ear and condition, each two.

The Polish variety are not of recent days nearly so numerous as they at one time were. A really excellent specimen we have not for some time seen. The exhibitors of this breed will not, therefore, have so many competitors to contend against; they ought not, however, on that account to be the less careful in the selection of their exhibition birds. There are three acknowledged varieties, White-crested Black, and Gold and Silver-spangled. In each of the three varieties, size of crest and shape of crest each count three; symmetry and condition, each two. The other points, however, differ. In the White-crested Black richest black plumage counts two; deaf ear, one; and crest of the purest white, and most free from black, two. The remaining points in the other two varieties are—colour of crest, one; plumage accurately marked according to the "Standard" rules, two; purity of ground colour, one; bars, one.

We are glad to see the French breeds of fowls increasing in popular esteem, and that an additional class has been assigned them this year at our provincial fair. There are of this class of fowls three recognised breeds—Houdans, Crève-Cœur, and La Flèche. To the Houdans are allotted six points, which count as follows:—Size four; crest four; symmetry, plumage, and condition, each two; five claws, one. The Crève-Cœur have also six points of excellence—viz., size four; crest and colour three each; shape, symmetry and condition two each; comb one.

The La Flèche have five points given them—size, five; comb, shape, and condition, each three; deaf ear, one.

Game Bantams are seldom exhibited at our shows. Their points are seven—smallness of size, shape of head and neck, of body and wings, of tail, of thighs, legs and toes, and condition, each two; colour, three. Sebright Bantams, Gold and Silver-laced, plumage most evenly and distinctly laced throughout counts four. Purity of ground colour in Silver, and richness and clearness of ground colour in Golden, comb, smallness, symmetry, condition and general appearance, each two; tail, one. Black and White Bantams are judged by one standard—purity of white, or richness of black; smallness and symmetry each count three; while comb, deaf ear, condition, and general appearance count two each.

In Turkeys, size, symmetry, and colour are the leading characteristics of birds for a show pen; while the same may be said of Ducks and Geese, with the exception of Black East Indian and Call Ducks, in which smallness of size is the chief feature.

Exhibitors should also bear in mind that to each distinctive breed are attached certain disqualifications, which birds selected for exhibition ought to be free from.

CRYSTAL PALACE POULTRY AND PIGEON EXHIBITION.

This, to be held on the 7th, 8th, 9th, and 10th of December, ought to be largest and most successful of the year. For poultry there are eighteen silver cups, or pieces of plate, varying in value from five to six guineas, in addition to the three money prizes in each class, of £3, 30s., and 10s. For the Pigeons there are seventeen silver cups, or pieces of plate, varying in value from five to three guineas, in addition to the three prizes in each class of 30s., 20s., and 10s.

SOUTHAMPTON POULTRY SHOW.

You announced my intention of collecting subscriptions for Light Brahma cups to be given at this Show. The following is the result of that collection:—Mr. Hickman, £1 1s.; Mrs. Williamson, £1 1s.; Mr. Crook, 10s.; Mr. Maynard, £1 1s.;

Mr. Dowsett, £1 1s.; Mr. Pares, £1 1s.; Mr. Rodbard, 10s.; Mrs. Turner Turner, £1 1s.; Mr. Crowley, £1 1s.; Mr. Worthington, 10s.; Mr. Seecombe, 5s.; Mr. Chisman, 5s.; Miss Harvey, 13s. Total, £10 10s. Mr. Dowsett has collected six guineas for a piece of plate, which will be awarded to the best pen of Light Brahmas at the next Birmingham Show.—H. M. MAYNARD.

I beg to call your readers' attention to the fact, that there is a Game cup, value five guineas, to be awarded to the best pen of any variety of Game. I should remind them that the entries close on the 20th inst.—S. SAMWAYS, *Bevois Town Hotel, Southampton.*

INQUIRY.

In your impression of the 6th of October there is an advertisement from one who signs himself J. Panshon, Downe Street, Driffield, and who represents himself as having 150 head of prize poultry for sale. Being in want of some Cochins I was induced to go over to find the man, but failed to do so, as I am ascertained there is no such person in Driffield. Report pointed to a person who, under this name, is endeavouring to sell some very inferior stuff, and whose hen-roosts are full of several kinds of disease. I merely write this as a caution to others whose time, like my own, is too precious to spend a whole day in searching for a man unknown in the neighbourhood he is said to live in. If people wish to dispose of their poultry, surely they should give a proper address.—EAST YORKSHIRE.

RABBITS AT THE COMING YORK SHOW.

I CONGRATULATE the Committee on the attractive prize list they have issued, and trust it will find favour in the eyes of all Rabbit-fanciers, and induce them to send numerous entries, so that the York Exhibition of this year may be as far superior in number of entries and excellence of specimens as it exceeds all previous years in the liberality of the prizes offered. It is not often we find two five-guinea cups and a silver medal given for rabbits, yet such is the case at York. The medal is from the neighbouring county (Lancashire), and I am glad to see this kindly feeling and interest manifested in such a manner by the fanciers, and I do hope to see more evidence of such feeling. I am not yet able to state the name of the Judge, but can assure all exhibitors that a good judge of Rabbits will award the prizes; and a full report in this Journal of his awards, and the particulars of excellence of each prizewinner, will be given by a gentleman well known for his ability to assume that office. Thus the Committee are doing all they can to add to the attractiveness of the Rabbit section of the Exhibition, and I am aware that a large number of entries will crown their efforts. There are eight classes for Rabbits, and the small two-shilling entry fee, and the good £1 and 15s. as first prizes, I think will induce a liberal response.—CUNICULUS.

HOW TO REMEDY THE DEFECTS IN BELL-SHAPED BEE-GLASSES.

HAPPENING to be at a dinner party lately, the conversation turned upon bees, and two or three of the company made remarks to the effect that very few swarms had been seen on the wing this season: whereupon a rich merchant, just returned from Burmah, stated that the country was quite overstocked with these honey-gatherers, and that no complaints as to swarms or their produce had ever been made in former days, when only a hive or two could be found here and there in a district.

Being anxious to hear the sage remarks of the returned foreigner, I inquired on what grounds he concluded the country was overstocked? To this he replied that it required an acre of pasture ground to maintain a cow, and that it would require the same extent of territory to maintain a bee. There was nothing, he added, to prevent a single bee from visiting and extracting all the honey from every flower within the space referred to during the season. It never once occurred to him that nectaries emptied one day might be replenished the next, or that periods might happen when supplies would be so abundant as to be all but inexhaustible. These facts I endeavoured to make apparent, but I fear without success. The mention of the discoveries made by Dzierzon was received with something more than a smile of incredulity, and I could not help thinking that my situation bore a striking resemblance to that of an old clergyman near Silloth, and a genuine son of Erin. A friend

called upon him one day to inquire how he was getting on. "Very badly," was the reply; "I have been here eleven years, and I don't think I have done any good." Then pointing to a gathering of Methodists in one of the fields, he exclaimed, "You have no conception of the pape I have to deal with; they are all teachers, but none of them are taught. When I tell them of the 'Principia' of Newton, they say it is all nonsense; or if I speak to them of manners, they say Lord Chesterfield was a fool." My auditory were evidently of the same opinion with the old clergyman's parishioners. They said plainly, though not in words, that parthenogenesis was nonsense, and that Dzierzon was a fool. But what can an apiarian expect when he throws his "pearls before pigs?" The readers of "our Journal" belong to a different class, and I have no doubt that most of them are ready to hear patiently any statements that may be honestly made, and to bring them to the test of experiments.

With their permission, then, I venture to say that the best bee glass that has yet been devised is that so well described by the "RENFREWSHIRE BEE-KEEPER" in "our Journal" of June 4th, 1868, and that the worst is the bell-shaped, which I have generally used and still continue to use in my apiary. Possessing several of the latter form, I was unwilling to throw them away; and this led me to adopt an expedient whereby their defects might be in a great measure obviated. The chief defect, as those who use them must know, is the difficulty which bees experience in ascending them. The bees' efforts to do so are repeatedly frustrated, and, when they succeed, the next difficulty is the fixing a foundation for their combs. Now the former of these inconveniences is not found in the form of glass devised by Mr. Mitchell, of Abingdon, and both may be overcome in the common bell-shaped by the following process:—Warm the glass before a good fire, exposing the interior to it, until it is sufficiently hot to melt wax. Then take a piece of clean comb, and draw parallel lines from top to bottom where you wish your combs to be fixed. Portions of comb will adhere throughout the lines to the heated glass, and these, if the temperature has been raised to the proper mark, will not only prove excellent bases for future operations, but will also serve as ladders, affording all needed facility of ascent to the bees. Having tried the process and found it successful, there is reason to hope it will succeed with others also.—R. S.

OUR LETTER BOX.

COCHIN PULLETS DYING (E).—You do not give us sufficient information about your fowls. From your description, we should say they become diseased after they come into your possession. If you will give us a description of the place they have, and the food afforded them, we shall be able to form an idea as to the disease and its remedy. At present all we know is that at certain intervals you lose one of your fowls.

FEATHER-LEGGED WHITE BANTAMS (G. M.).—There is a very handsome breed of White Bantams, called the "Booted Bantams." They have now become scarce because all Bantam-fanciers turn to the Game. They have not, and never had, a fixed weight, but, in common with all others, the less they weigh the better and more valuable they are considered.

BIRMINGHAM POULTRY SALE (W. Carr).—You had better write to Mr. Lythall; he can give you authentic information.

ANDALUSIANS (Very Old Subscriber).—The Blue Spanish or Andalusians rank as a distinct breed. Without giving an opinion on the Darwinian theory, we believe they are offshoots from the Spanish, just as we believe the modern Spanish is an offshoot from the old Minorca. They have been shown as a separate breed everywhere, but never in sufficient numbers to entitle them to a class. They always belong to the "varieties," and compete therein. Mr. James, of Fareham, used to keep them very successfully. Apply for a sitting of eggs to the person who shows the best of the breed at Birmingham.

HEN'S HEAD SWOLLEN (J. W.).—If the swelling be a hard one, you can either treat it with iodine ointment, or you may carefully open the skin, and squeeze the swelling out by pressing the lower part. If it be soft it is merely the result of cold, and as Braamias are not subject to roup it will have no consequences. The treatment will be to give only ground food for a day or two, to administer stimulants in the shape of bread and strong beer, and to give either Bailey's Pills, or pills of campher the size of a garden pea—two at a time and once per day.

BRAHMA COCKEREL (Brahma).—We should not hesitate to breed from him.

AYLESBURY DUCKS' BILLS BECOME YELLOW (E. H.).—It is a very vexatious thing that the bills of Aylesbury Ducks turn yellow, but it is not less true that they do so in certain localities. Water that runs off peat or heath, stagnant ponds that receive stable or yard manure, and dirty water of every kind, are injurious to the colour of the bill. A clear running stream, access to meadows at daybreak when the grass is covered with cold dew or white frost, and the mixture of small pebbles or stones with the only water they have (where it is supplied artificially), are all beneficial to the colour. It is hardly necessary to say gravel stones are very bad to mix with water.

ANTWERP PIGEONS (Severel).—It is only necessary to refer several correspondents to our number for February 17th, for the Birmingham Columbarian Society's standard of merit, to which may be added, in answer to one inquirer, "TRUE BLUE," that the white-eyed specimens of

the Antwerp are very numerous, and amongst them are some of the most perfect birds, more especially amongst the Red Chequers and Blues, although all the varieties are pretty sure to breed some white-eyed birds, which is not a positive defect, yet the fact of its similarity to the eye of the Barb, leads us to prefer the deep blood-red-coloured eye; yellow and dingy-coloured eyes are objectionable, and lack that fierce, fiery appearance so essential in that great point, the eye of an Antwerp.

VARIOUS DISEASES IN ONE LOFT OF PIGEONS (David Laurie).—The various diseases you mention as being rampant in your Pigeon loft—falling of the feathers, or feather-rot, blindness in young birds, formation of matter in the joints, and loss of power in the legs, all point to one cause—viz., bad constitution, and that in no common degree. Most probably your stock have in other hands been bred in-and-in for generations; and bad food, bad water, bad air, and crowded and unclean lofts, causing the birds to sleep in air charged with exhalations from dung, have helped to bring about your troubles, and your own care may have been fruitless to prevent what former years have caused. Fresh blood and frequent crossings will help you to get rid of the scrofulous taint; or, better still, get a new set of birds, for scrofula lingers for generations.

REMOVING STOCKS (Brixtonensis).—We do not think you need fear the effect of the removal on your ponderous stocks in Woodbury hives. More harm than good would be likely to arise from disturbing the hives in order to insert a transverse notched bar at the bottom of the frames.

METEOROLOGICAL OBSERVATIONS

In the Suburbs of London for the week ending October 18th.

DATE.	BAROMETER.		THERMOMETER.				Wind.	Rain.
			Air.		Earth.			
	Max.	Min.	Max.	Min.	1 ft.	2 ft.		
Wed... 12	29.212	29.177	65	48	53	50	S.	.05
Thurs... 13	29.688	29.250	57	43	53	50	W.	.10
Fri... 14	29.935	29.826	63	25	42	51	N.E.	.01
Sat... 15	29.010	29.717	61	30	48	50	S.	.08
Sun... 16	29.401	29.127	59	46	51	50	S.	.34
Mon... 17	29.753	29.349	58	27	53	51	W.	.04
Tues... 18	29.850	28.606	59	47	50	50	S.	.66
Mean...	29.678	29.436	60.31	38.00	51.43	50.29	..	0.58

- 12.—Showery; drizzling rain; exceedingly boisterous.
- 13.—Exceedingly boisterous; boisterous; rain.
- 14.—Cloudy but fine; very fine; clear, starlight.
- 15.—Dense fog; exceedingly fine; clear and fine.
- 16.—Rain; heavy rain; cloudy; very damp.
- 17.—Very fine; showery; clear and fine.
- 18.—Very fine; overcast; densely overcast.

COVENT GARDEN MARKET.—OCTOBER 19.

We have still to report an excessive supply in most of the ordinary kinds of produce, orchard fruit being especially abundant, and large consignments of Pears from the south-west of France reach us every week. The Potato trade is somewhat dull, with large stocks on hand, chiefly Regents and Flukes, ranging from 80s. to 120s. per ton.

FRUIT.

	s.	d.	s.	d.	s.	d.	s.	d.	
Apples.....	1	0	2	0	Mulberries.....	1	0	2	0
Apricots.....	0	0	0	0	Nectarines.....	0	0	0	0
Chestnuts.....	6	0	14	0	Oranges.....	100	20	0	0
Cherries.....	1	0	0	0	Peaches.....	0	12	0	0
Currants.....	1	0	0	0	Pears, kitchen.....	1	0	2	0
Black.....	0	0	0	0	dessert.....	0	0	0	0
Figs.....	2	0	2	0	Pine Apples.....	1	0	3	0
Fibers.....	1	0	2	0	Plums.....	1	0	6	0
Cobs.....	1	0	2	0	Quinces.....	1	0	0	0
Gooseberries.....	0	0	0	0	Raspberries.....	1	0	0	0
Grapes, Hothouse.....	1	0	5	0	Strawberries.....	1	0	0	0
Lemons.....	1	0	16	0	Walnuts.....	10	0	16	0
Melons.....	1	0	4	0	do.....	100	1	0	2

VEGETABLES.

	s.	d.	s.	d.		s.	d.	s.	d.
Artichokes.....	0	10	0	0	Leeks.....	1	0	0	0
Asparagus.....	0	10	0	0	Lettuce.....	1	0	3	0
Beans, Kidney...& sieve.	3	0	4	0	Mushrooms.....	1	0	2	0
Broad.....	0	0	0	0	Mustard & Cress..	1	0	3	0
Beet, Red.....	2	0	8	0	Onions.....	1	0	6	0
Broccoli.....	0	9	1	6	pickling.....	0	4	0	0
Brussels Sprouts...& sieve	3	0	4	0	Parsley.....	1	0	0	0
Cabbage.....	0	1	2	0	Parsnips.....	0	10	0	0
Capsicum.....	0	10	1	0	Peas.....	0	9	1	0
Carrots.....	0	4	0	8	Peas.....	0	6	0	0
Cauliflower.....	2	0	6	0	bushal.....	2	0	4	0
Celery.....	1	6	2	0	Kidney.....	0	3	0	4
Coleworts.....	0	6	0	0	Radishes...& doz. bunches	0	0	0	0
Cucumbers.....	0	6	1	0	Rhubarb.....	0	0	0	0
pickling.....	0	2	0	4	Savoy.....	0	0	0	0
Endive.....	2	0	0	0	Sea-kale.....	0	0	0	6
Fennel.....	0	3	0	0	Shallots.....	0	6	0	0
Garlic.....	0	0	0	0	Spinach.....	0	2	0	6
Herbs.....	0	3	0	0	Tomatoes.....	0	1	0	6
Horseradish.....	3	0	5	0	Turnips.....	1	0	6	0
					Vegetable Marrows...& doz.	2	0	8	0

POULTRY MARKET.—OCTOBER 12.

STILL moderate supplies, but no demand at all. Pheasants come in moderately, as the leaf being on, but few are killed.

	s.	d.	s.	d.		s.	d.	s.	d.
Large Fowls.....	2	6	3	0	Pigeons.....	0	8	0	9
Smaller ditto.....	2	0	2	6	Rabbits.....	1	4	1	5
Chickens.....	1	9	2	0	Wild ditto.....	0	8	0	9
Ducks.....	2	0	2	8	Hares.....	2	6	3	0
Geese.....	6	0	7	0	Partridges.....	1	4	1	6
Pheasants.....	3	0	3	6	Grouse.....	2	0	2	0

WEEKLY CALENDAR.

Day of Month	Day of Week.	OCT. 27—NOV. 2, 1870.	Average Temperature near London.			Rain in last 43 years.		Sun Rises.		Sun Sets.		Moon Rises.		Moon Sets.		Moon's Age.	Clock after Sun.	Day of Year.
			Day.	Night.	Mean.	Days.	m.	h.	m.	h.	m.	h.	m.	h.	Days.	m.	s.	
27	TH		55.1	48.4	46.7	27	46	af 6	41	af 4	16	10	49	af 6	3	16	1	300
28	F	ST. SIMON AND ST. JUDE.	54.5	35.9	45.2	27	48	6	39	4	34	11	37	7	4	16	6	311
29	S		54.0	35.7	44.8	29	50	6	37	4	after.	37	8	5	16	10	302	
30	SUN	20 SUNDAY AFTER TRINITY.	54.9	34.9	44.6	22	51	6	36	4	31	1	42	9	6	16	13	303
31	M		54.0	38.0	46.0	22	53	6	34	4	8	2	52	10	7	16	15	304
1	TU	ALL SAINTS.	54.3	37.9	46.1	25	56	6	32	4	40	2	morn	8	16	17	3	5
2	W	Royal Horticultural Society, Fruit, Floral, [and General Meeting.]	54.4	37.3	45.8	19	57	6	31	4	5	3	8	0	9	16	18	306

From observations taken near London during the last forty-three years, the average day temperature of the week is 54.4°, and its night temperature 37.3°. The greatest heat was 67°, on the 31st, 1854; and the lowest cold 22°, on the 28th, 1836. The greatest fall of rain was 1.03 inch.

SLOW COMBUSTION—ENDURING FIRE—ECONOMY IN FUEL.



HAVE read with interest the various notices which have from time to time appeared in the Journal, giving particulars of different boilers and modes of heating glass houses.

The plan I have adopted, and which has been attended with marked success, although not new, yet is not sufficiently known, and therefore may be of interest to those amateurs who, like myself, are obliged personally to attend to the work required.

I must preface my statement by mentioning that my house is 35 feet long, 14 feet from back to front, and 13 feet high. It is heated with hot water by one of the smallest-sized tubular boilers, having 4-inch flow and return pipes running round the two ends and back of the house.

Whether or not it was from the position of the furnace house I cannot say, but whatever the fuel I used I found a difficulty in keeping the fire burning for any length of time so regularly as I desired, in consequence of the draught through the ashpit door setting on one side of the fire. As a result it frequently went out, and the heat was irregular. After trying several plans to prevent this, I at last had two holes, each about the size of a crown-piece, drilled in the ashpit door. Over these I had soldered a good-sized brass sliding valve, similar to those frequently used in doors to ventilate rooms. The result was all I desired. By this simple plan I obtained a properly distributed draught under the whole of the fire, and by a little attention to the damper and quantity of air admitted through the valve, I was soon able to ascertain the amount of draught requisite to keep the fire at its proper heat.

I also found that by only feeding the fire twice a-day—the first thing in the morning, and the last thing at night—and just clearing the bars, if needed, the fire was kept constantly going, and during the three winters once only has the fire gone out, and on several occasions it has burned for twenty-four hours without additional fuel.

I have often been surprised at the small amount of air needed to keep up a bright clear fire. With the valve open in each span not more than the thickness of a new sixpence, I have kept the house at from 40° to 45°, with an external atmosphere showing 16° of frost. With a temperature of 6° to 8° below freezing I have kept the house at 40°, at the same time having the two end ventilators open.

The great advantages of the plan are—the length of time the fire can be kept burning at a proper heat without attention (a great object to an amateur engaged, like myself, in business away from home), and the perfect control over the heat, be it little or much. One essential to success is keeping the ashpit clear of dust and ashes; I have it cleared out two or three times a-week if needed.

During the last two years the fire never went out from the time I commenced until I ceased heating the house (about five months each season), excepting when I drew

the fire to clear the bars, and this I did about once a-month.

Not wishing to annoy my neighbours with smoke, I tried various kinds of fuel—breeze from the dust yard, coke breeze, furnace coke, gas coke, and Welsh anthracite smokeless coal. I carefully noted the cost and result of each kind, and finally adopted the Welsh anthracite coal as being the cleanest, as cheap as any, if not the cheapest, and by far the easiest managed. Residing in a northern suburb of London, I have no difficulty in procuring this; and, at 25s. per ton, I find its cost does not exceed 3s. 6d. per week. I have been surprised how little this cost was exceeded, when on several occasions, by way of experiment, I gave an increased draught to test the power of the fire under the plan adopted. For the reason stated, I have always a smokeless fuel, and therefore cannot say how ordinary coal would answer.

The size of the brass valve is 6 inches long, and the whole affair cost about 8s.

I may attach a fancied value to the results of my experience, but I give the particulars for the benefit of your amateur readers, if you think them worth inserting in the Journal.

I found by repeated experiments that by using the valve only I could drive the heat far in excess of anything I might require, and I also had the satisfaction of knowing that, however sharp the frost might threaten to be before morning, I could always retire to rest without any fear about the greenhouse fire.—R. S.

JASMINE GRANDIFLORUM FOR AUTUMN AND WINTER FLOWERING.

There are some flowers which from their purity of colour, beauty of form, and perfume are general favourites, and of these the Sweet Jasmine is undoubtedly one. It may not be in such high repute as the Rose, but it is one of many old plants without which no garden is complete.

Jasminum grandiflorum, though not such a favourite as the old Sweet Jasmine (Jasminum officinale), is nevertheless an old plant, having been introduced in 1629. It has, no doubt, found a home in some gardens since that time, yet it was only of late years that this plant came to be cultivated, and even now it is not so common as it deserves to be; indeed, it ought to be grown in every greenhouse. Those who do not possess it would by now securing plants obtain a fine, white, sweet-scented flower that may be had in blossom early in spring by slight forcing, and the same plant will flower again in autumn, and continue expanding its blossoms successively during the dull autumn and early winter months.

In appearance it is a *far simile* of the Sweet Jasmine, with this difference, that its leaves are larger, the flowers more than twice the size, some double, but not twice as sweet, though it is very sweet-scented, and all the flowers do not open at once, but succeed each other as in the Sweet Jasmine. We cannot cut the whole produce of a stem at once, but each flower has a good stalk, and is quite large enough by itself. It would be useless attempt-

ing to grow this as a pot plant on its own roots—at least I have not seen it in a satisfactory state when grown in that way. It requires to be grafted, and on a stem from 6 inches to a foot high it is very pleasing. It is best grafted on the old sort, or Sweet Jasmine, and the operation may be performed in spring when the stocks are beginning to grow, the scions being kept back by cutting them a month previously, and keeping them fresh by inserting their lower ends in wet clay; or a Potato pot in the soil will do as well. Whip-grafting will answer, but the continental growers practise cleft-grafting with great success. After tying with bast matting, and covering with grafting wax, place the grafts in a gentle hotbed or a house with a temperature of from 50° to 55°, and cover with a hand-glass, so as to keep them close. The glasses ought only to be taken off to see whether water is required, or to admit a small quantity of air if likely to be damp. When the grafts begin to grow admit air in moderate quantity at first, increasing the amount as they advance, and hardening off by degrees. When the shoots are about 6 inches long the plants may be moved to the greenhouse, assigning them a light airy position. They will flower in the course of the summer if sufficiently strong. By autumn they will have firm shoots; to insure their ripening, give them the lightest and most airy position the greenhouse affords, keeping them dry at the root, but not so much so as to cause the leaves to flag and fall prematurely.

When the leaves fall place the plants in the coolest part of the house, or in a cold pit or cool house, and in December cut them back, so as to leave about an inch of last year's wood, two or three joints being enough. If the plants are in small pots transfer them to a larger size, using a compost of light fibrous loam two parts, one part sandy peat, and one part of leaf soil, with a free admixture of sharp sand. Good drainage is necessary, also a moderate-sized pot. Six inch pots are quite large enough for the next two or three years. After watering, the plants may be placed in a house with a temperature of 45°, progressively increasing to 50° or 55°, and they will flower well early in spring. They will, of course, be placed in the greenhouse when in flower, and should have due care as to water, and in a light airy position the wood will be ripened by May. Then, or early in June, cut the shoots back to within a few eyes of their base—two or three are enough—and keep them rather dry at the roots for a fortnight, then place them in a light airy position, watering as required, and occasionally syringing overhead. The plants will form fresh shoots, and flower again in autumn up to Christmas in a greenhouse with a temperature of from 40° to 45°.

Nice plants may be obtained at most nurseries, many of them in a flowering state; indeed it is not practicable to grow grafted plants without flowering.

I may say that the Sweet Jasmine succeeds admirably in the same way. Grafted plants are best for pots, though others answer well, only they are more liable to put out long shoots, which should be stopped at the third or fourth joint, being careful to retain the short-jointed flowering parts.—G. ABBEY.

A FEW APPLES, PEARS, AND PLUMS FOR SMALL GARDENS.

PEARS.—1, Beurré Bachelier, December; 2, Bergamotte d'Espéren, March; 3, Beurré d'Amanlis, September; 4, Beurré Hardy, November; 5, Beurré Superfin, October; 6, Williams' Bon Chrétien, September; 7, Doyenné du Comice, November and December; 8, Joséphine de Malines, February and March; 9, Louise Bonne of Jersey, September and October; 10, Madame Treve, August and September; 11, Winter Nelis, January; 12, Olivier de Serres, March and April.

The above are all of first-rate quality, and bear in the west, south, and south-east of England freely as bushes and pyramids when grafted on the Quince stock.

APPLES.—*Kitchen*—1, Blenheim Orange, November; 2, Cox's Pomona, December; 3, Dunelov's Seedling, March; 4, Gooseberry Apple, May; 5, Hawthornden, August to November; 6, New or Winter Hawthornden, January; 7, Rymer, December to April; 8, Small's Admirable, December; 9, Lord Suffield, October; 10, Warner's King, very large, November.

APPLES.—*Dessert*—1, Cox's Orange Pippin, November; 2, Duke of Devonshire, February; 3, Early Harvest, August; 4, Keddlstone Pippin, March; 5, Lodgemore Nonpareil, April and May; 6, Melon Apple, December and January; 7, American Mother, October; 8, Pittsston Pineapple, December; 9, Reinette Van Mous, January; 10, Reinette du

Canada, April; 11, Sturmer Pippin; 12, White Nonpareil, March.

All the above bear well as dwarfs and pyramids on the English Paradise stock, no matter what kind, for all the Paradise stocks root freely on the surface, and form prolific trees. The French Paradise forms very dwarf trees; for pots or very small gardens they are really curious and pretty, as trees here in 4-inch pots are like Japanese trees, so full are they of blossom-buds. In France this stock requires a heavy tenacious soil, as the heat is apt to scorch their roots, always near the surface.

PLUMS.—*Kitchen*—1, Victoria; 2, Autumn Compôte, which succeeds it, and is much like it, but better; 3, Prinée Eglebert, large and rich; 4, Belle de Septembre, very late and large; 5, Early Rivers or Early Prolific, July and August. This is the most abundant bearer of all Plums, and, indeed, the best culinary Plum known, for preserved without sugar it retains its exquisite flavour for a year or more (I enclose my wife's receipt, see page 342—it is very old—for preserving Plums without sugar; it seldom or never fails if the bottles or jars are placed in a dry room). 6, Oullins' Golden Gage, very large, early in August, excellent for preserving, a great bearer. The tree is almost too vigorous for a small garden; as a standard it is a giant—a standard tree here ten years old bore six bushels of large fruit. 7, Mirabelle, as a bush only; this charming little yellow Plum is largely used in the east of France for jam and preserving; its perfume is *sui generis* and exquisite. 8, Early Orleans, early, and a great bearer.

PLUMS.—*Dessert*—1, Angelina Burdett, hardy and excellent; 2, Belgian Parole, earlier than the preceding, good for both purposes; 3, Jefferson, large and good; 4, Bonnet d'Évêque, one of the latest, hardest, and richest of Plums; its fruit, of a bright purple, are still (October 18th) on the trees quite hard, yet juicy and rich; 5, Transparent Gage, the most noble Plum known; 6, Boddart's Green Gage; 7, Early Green Gage; 8, Reine Claude de Bavay, one of the finest of Gage Plums, very hardy and late.

All the Plums I have mentioned are perfectly hardy, and will bear well as bushes and pyramids in districts south of the Trent, and even farther north in sheltered places. I have thus far complied with Mr. Abbey's request. There are, doubtless, many kinds as good as those I have mentioned, but I have given, according to my experience, the names of varieties that everyone may plant with safety.—THOS. RIVERS.

ROOT-PRUNING FRUIT TREES.

OVER-LUXURIANT trees being benefited by this operation, and this being the season for so treating them, I would ask for more attention to it. I am well aware that it takes time to root-prune in a proper manner, but it is not an annual operation needed by each tree. As many of the trees as can be root-pruned in a year should be so treated, and then by working systematically the whole may be compelled to grow in the manner the cultivator requires.

In root-pruning, by cutting hard back the coarse roots which supply the tree with an excess of sap, a number of fibrous roots will be formed, these being the kind required to produce fruitful wood. In doing this, care is necessary lest the fibrous roots already in existence get damaged, as injury to them would most assuredly debilitate the tree operated upon. The points of all damaged roots must be pruned back to where they are sound, in order to encourage young roots; but there are often cases in which the whole of the tree is growing too rank, through over-rich borders, or neglecting to cut back the runaway roots at their origin, and these will require careful lifting, digging a deep trench around them, and working the soil away from the roots with a steel fork. The soil should be moist, so as to separate readily from the roots, or these will be lacerated. Let the soil be thrown out of the trench as the roots are freed from it, keeping the ball undermined so as to get easily at the pert pendicular roots, which must be shortened back and spread out horizontally when the tree is replanted.

With respect to young trees, it is by far the best plan to lift and replant them every second or third year. By this means, with the judicious use of the pruning knife among the roots, fruitful trees, with an abundance of healthy fibrous roots will be produced; and if a few of the trees are found weak, some fresh loam can be added at the time of replanting. Any coarse shoots, which will usually be found unripe, will be best wholly removed. As the trees become older, lifting them entirely will not be necessary very often, but on the appearance of any gross shoots in the growing season these can be frequently

pinched back; and in the following autumn, before the leaves have fallen, it will be well to open a trench round them at a good distance from the base of the tree, and sever all runaway coarse roots with a clean cut, refilling the trench with fresh soil when obtainable. As the trees become thoroughly established, their

roots having ramified in all directions—as far, in fact, as their powers of extension permit, very little manipulation will keep them in order. Being healthy their fruitfulness will increase with age, and nerve the cultivator to the continued study of Nature's ways.—T. C. SAGE.

GROUND LEVELLING AND PRACTICAL GARDEN PLOTTING.—No. 2.
DRAWING PLANS.

THE first thing required is a case of mathematical instruments, which generally contains a pair of large compasses, provided with shifting legs—viz., the steel, the pencil, and the inking legs (the latter two are used for describing large circles in pencil or ink, and the steel leg for dividing lines and measuring distances accurately); a drawing pen for drawing straight lines in ink; a bow pencil; and a bow pen. The use of the bow pencil is to draw small circles, and the bow pen repeats the pencil work in ink. The ink used should be Indian ink, and should be put between the nibs with a camel-hair brush. Before drawing a line in ink try the pen on another piece of paper, in order to ascertain if the line is thick enough or too thick; if not right, adjust the pen by means of the screw. Before putting the pens away pass a piece of blotting paper between the nibs, so as to clear away the ink. The case also contains a rule with a bevelled edge to use when inking lines. The bevel must be turned downwards; this will prevent the work being smeared.

To Construct a Scale of Equal Parts (fig. 4).—Let it be required to construct a scale of 8 feet to the inch, which is the first scale I have used in these notes. A scale of 8 feet to the inch means that 1 inch on paper represents 8 feet on the ground. Draw a line of any length, and divide it into inches; divide the first inch on the left-hand side into eight equal parts, each part representing 1 foot. If 8 feet are required, put one end of the compasses or dividers down on point 8, extend the other end to point 0, which is 1 inch, and represents 8 feet. If 9 feet are required, extend the dividers to the first division of the divided inch on the left-hand side of 0. If 10 feet are required, extend the dividers to the second division, and so on. If 16 feet are required, put one end of the dividers down on point 16, and extend the other end to point 0, which distance is 2 inches, and represents 16 feet. If 17 feet are required, extend the dividers to the first division as before.

By dividing one of the eight divisions shown into twelve equal parts, each part will represent 1 inch.

In drawing a plan that is required to be transferred to the ground, it is safer to take the scale from a rule which has different scales marked on it and is generally supplied with the case of instruments, as by constantly applying the dividers to the paper the holes pricked by the points will get larger and lead to confusion.

The next three scales used in these notes are 12, 16, and 24 feet to the inch. All three are applied as the above; but it will be manifest the more feet there are to the inch, the more space the design will occupy on the ground.

A Drawing Board is necessary, also a T square, as shown. The drawing board should be about 2 feet long, and 18 inches wide; it must be smooth, flat, and perfectly square. On this board the paper on which the drawing is to be made should be properly fastened, which is done by pasting the edges of the paper to the board. This is only necessary when the work is likely to take some considerable time; for such exercises as

are contained in these notes it will be sufficient to fasten the paper down by means of drawing pins.

The T Square (a, fig. 5), is used to square that portion of the paper on which the plan is to be drawn, also to draw parallel lines and erect perpendicular lines; but in

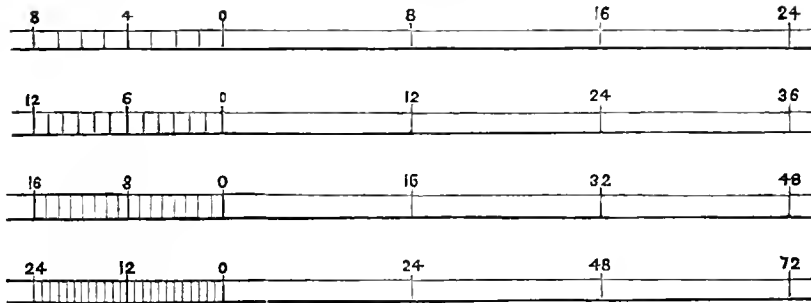

Fig. 4.

case the board is not perfectly square, the T square should be worked against the left-hand edge of the board only—that is, to draw horizontal lines. All perpendicular lines are best drawn by placing the set square or triangle (b, fig. 5) against the T square, as shown; by so doing the lines will be at right angles to each other. All drawings should be first made in pencil, and afterwards traced in ink. The drawings may be cleaned, or faintly increased, with a piece of Indian rubber or stale bread.—M. O'DONNELL, Gardener to J. E. Leeming, Esq., Spring Grove Richmond.

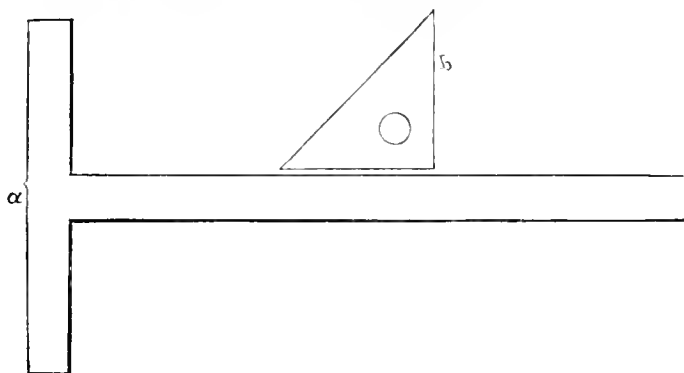

Fig. 5.

LINARIA CYMBALARIA.

THIS pretty little native plant, called by some the Ivy-leaved Snapdragon and by others the Ivy-leaved Toad Flax, which I think is the correct name, presents such a fanciful and pleasing appearance in its natural state, as to be worthy of special notice;

for when a plant possesses, as this Linaria does, such valuable qualities as hardness, handsome foliage, dwarf habit, and free flowering, combined with very little or no difficulty in its cultivation, it is a matter of regret that it should not be more

frequently used for the purposes for which it is best adapted. These are the covering of such old walls as are becoming unsightly through decay, or where it is difficult to get any other plant to establish itself, and for planting in the alpine or rock-work garden. In either of these positions it may be most advantageously and easily used, and its trailing branches of Ivy-like foliage thickly set with bluish purple flowers, make it a subject to be admired by most people during the autumn and winter months, when it is most attractive and serviceable.

I have sometimes seen this plant growing in little tufts on walls that have deciduous plants trained against them, so that in winter, when the plants have shed their foliage, it very effectually hides their naked stems, and at the same time clothes the bare wall to a great extent. Again, where it is necessary to have elevated rough stone edgings to garden walks, this little British plant will be found one of the best to grow there, and its delicate branches, when trailing over the stones, are sure to please.

Lunaria Cymbalaria reproduces itself very freely from seeds, and where any of them can effect a lodgement it will be sure to germinate when a favourable time arrives. It is difficult to induce it to establish itself very near walls or smooth surfaces, but where a thimbleful of earth can be deposited, and moisture retained in it, that difficulty passes. In very heavy retentive soils the plant does not thrive so well; therefore, if it be desired to plant it where such a soil prevails, fully 50 per cent. of old mortar rubbish must be added, and the plants will be found to succeed well, especially if the position is elevated.—Tnos. RECORD, *Hatfield Park*.

PEAS IN 1870.

WITH me this has been the most extraordinary year on record for heavy crops of Peas, and I believe one of the chief reasons has been the treatment given. Peas, like many other things, require good cultivation, otherwise they tell tales.

My treatment is as follows:—In January or February I trench the ground to the depth of 3 feet, giving a liberal dressing of manure and quicklime, for I consider it is the deep cultivation which is the great secret of successful Pea-growing. With me the hotter and drier the summer the more luxuriant are the Peas and the drier the produce, the heat causing the roots to strike farther into the ground; and there being plenty of room for them to run, and plenty of manure to feed on, the crop cannot but do well, and thus success is insured. Up to October there was not the least indication of mildew. Mildew is a sure sign, either of the ground being poor, or there not being depth for the roots; then, owing to there not being many roots, or from these being unable to penetrate into the soil to a sufficient depth, the plants suffer from the sun. Defective drainage is another cause. I have seen Peas in perfection, and after a week of sudden heat they have been a failure owing to the above reasons.

I do not sow the first Peas till March, as I find they come in as early as those sown in November, besides bearing a much better crop. The birds and mice always make great havoc among Peas that remain in the ground so long. I give plenty of room—9 feet from row to row, planting Cauliflowers, Brussels Sprouts, and Winter Greens between; and I find this tends to prolong the gathering season, the intermediate crops helping to keep the roots cool, and yet not keeping the sun from doing its duty to the tops. I should add my kitchen garden is in first-rate condition, being very rich and well drained.

I grew this season twelve varieties. The first, Ringleader, was gathered June 18th; the last, Veitch's Perfection, on September 30th for dishes, and for soups a week later, thus giving a period of fifteen weeks for the use of this delicious vegetable. During the fifteen weeks the gatherings averaged three per week at least. Peas, where practicable, should be grown on different ground every year.

I will now take the different varieties in the order in which they were gathered:—First, Sutton's Ringleader, gathered June 18th; this is the earliest and best-flavoured kind with me, is very prolific, and 10 lb pods and peas are the largest of the first early sorts. This attains the height of 3 feet 6 inches. Next comes Carter's First Crop, gathered June 24th. This is a very useful Pea, but smaller than Ringleader, and not so tall by a foot. These are the only two of the first early I intend growing next season. I had both Dillistone's Early Prolific and Sangster's No. 1, but they are inferior to the two named. Advancer is a good Pea, coming in a few days later than Carter's First Crop. I also sowed this in the middle of June, and it came in

very useful in September. Laxton's Prolific Longpod came in during the first week of July. This is, as it is named, prolific, but when it came to be cooked it was the worst-flavoured Pea of the season. I was never more disappointed.

I now come to one of the best of Peas, Beck's Prizetaker, which I began gathering in the second week of July. This is undoubtedly one of the best varieties grown; its flavour is delicious, it is an extraordinary bearer, and it continues long in yield. Champion of England followed the week after; this well retains its reputation as being the best flavoured of the summer Peas. It is also an excellent cropper, and is a good companion to Beck's Prizetaker, the height of both being about the same, 6 feet. Maclean's Wonderful is excellent, and its height being only 3 feet, it ought to be more grown, for it is a first-class Pea and very prolific. This brings me to the end of July or beginning of August.

Harrison's Glory came next in rotation, but as it has now only done moderately well for two years, I must discard it. To Ne Plus Ultra I recommend every one to give a trial, for, taking into account its flavour, its productiveness, and the length of time it remains in good bearing, it is unrivalled. This came in at the middle of August. Prince of Wales is well worth growing as a late Pea, though it gives way to the next and last on my list, Veitch's Perfection. I made two sowings of this; the first came in during the third week in August, the second in the first week in September, and I gathered till September 30th. As a fine-flavoured late Pea, there is nothing to equal this.

In conclusion I will give a list of the varieties which proved best this year. I scarcely know whether for midsummer use Champion of England, Ne Plus Ultra, or Beck's Prizetaker takes the lead, but I rather incline to Ne Plus Ultra. Of the early varieties Ringleader stands by itself; Maclean's Wonderful follows; then Ne Plus Ultra, Prince of Wales, Advancer, and last of all, and best of the latest, is Veitch's Perfection. This list I am quite aware contains none of the new kinds of which so much is said, and which I hope this next season to grow, but is composed of what may be considered old standards.—STEPHEN CASTLE, *Bent Hill Gardens, Prestwich*.

THE ECKLINVILLE SEEDLING APPLE.

WE have been informed by Messrs. Dickson & Son, nurserymen, Newtonards, near Belfast, that the Apple we referred to lately as Eckland Vale should be called Ecklinville. It was raised at Ecklinville, near Belfast, by a Scotch gardener named Logan, along with another dessert Apple named Logan's Seedling. Both of these Apples are of good quality, and to be found in the nurseries in Ireland.

We have another communication relative to the same Apple, from Messrs. Irvine & Son, nurserymen and seedsmen, Ayr. They say—"The Ecklinville Apple is well known in this district, and has been extensively propagated by us for upwards of twenty years. We obtained it of a neighbour, who had it from Mr. McInachan, gardener at Ecklinville, and its many good qualities, especially as a baking Apple, have made it a general favourite here."

We have third letter on the same Apple. It is the following—"It is some ten or more years since I received this kind of Apple from Ireland, under the above name. I have it now before me, with Small's Admirable and Stirling Castle Pippin, and have just tasted them. The Ecklinville has tender flesh, is juicy, and the most acid of the three. Next to this in pleasant acidity is the Stirling Castle. Small's Admirable is not sweet, but more so than the others. As to their appearance, they are so much alike as not to be distinguished even by a good judge. The Ecklinville has numerous small brown specks on its skin; the other two are quite clear, and are handsomer fruit than it. This may, however, be accidental. They are all three of dwarf habit, and most abundantly fruitful. The Stirling Castle is more upright in growth than the Admirable, and this is a distinguishing point, the only one, in its character."—T. R.

POTATOES.

I WAS never more forcibly struck by the utter impossibility of laying down any positive statements on the subject of Potatoes, than by reading the short account of your correspondent "M. H.," October 13th, page 287, concerning the Lapstone. I have ever maintained that in point of flavour and general excellence it is the best of all Potatoes, but I have at the same

time always deplored its great fault—viz., its delicacy of constitution, and I have never considered it a large cropper. This year has so completely confirmed my opinion, that I felt almost inclined to say I must only grow a very few Lapstones for the future. I grew thirty-six sorts—of these more anon—and of all the thirty-six the Lapstone was the most diseased; all the finest tubers were bad, and I should think that at least three-eighths of the crop went. I may say that I grew it in two situations—in my garden, and in a pasture which had not been turned up for a great many years, and which had not a particle of manure; that I took up one half of the crop in August and the other half in September, and that both were equally attacked by disease. How, then, can we account for the different experience of "M. H." and myself? and is it not hopeless to lay down any positive statement? Or can it be that "M. H." grew the Lapstone at all? He says, "Haigh's or Lapstone Kidney." There is a Haigh's Kidney as well as the Lapstone, and I believe it is less liable to disease. This may be the solution.

I see in the interesting account of Admiral Hornby's Potato produce that Dawe's Mitchless and Webb's Imperial are set down as giving different amounts of produce, but I have always believed them to be the same. If I am correct it will rather detract from the value of the return.—D., Deal.

The remarks of Mr. G. Abbey on Potatoes, in your number of October 13th, are very interesting and instructive. As a grower on a moderate scale, I can supplement his paper by one or two words on the mode I adopt, and which has been this year particularly successful. I always have the rows of Potatoes planted, as far as possible, due north and south. This lets in the full sun between the rows. The tubers were planted rather deeply to avoid the necessity of earthing-up. As soon as the stems appeared the rows were flat-hoed, and all the weeds carefully raked off the ground. The only attention they had afterwards was as follows:—A light boy of about eleven years of age passed along the rows, treading as little as possible, and pulled up every weed by the roots, putting them as he went along into a little basket which he carried on his arm. This was repeated several times. The consequence was that the ground was kept thoroughly clean, and the remaining fibres of the tubers undisturbed. I had a magnificent crop, and also got rid of many basketsful of weeds.

The kinds I grew were Alma, Paterson's Victoria, and the Pink-eyed Fluke from Scotland. Of the second kind the haulms were from 6 to 7 feet high, but the produce was marvellous.

I think the manure ought not to be put in too green. It should have passed through the first stage of decay, and be forked-in during November. The soil will take up all the matter suitable for the food of the tubers, and the benefit will be secured for after-crops.

A boy or girl kept at Potato-weeding will do great service, and may be had for about 1s. 6d. per-week.—F. H. POLTER, Cheltenham.

GLAZING AND PAINTING GARDEN STRUCTURES.

I WOULD as a matter of choice paint the outside of glass houses once every year; I should thus have them always neat and clean, and avoid the trouble of scraping and scratching. When sashes have been long neglected there must be a cleaning and reputting before there can be any painting. On the one-coat-every-year system I hardly know how long good putty would last, as it would not have a chance to crack and let the moisture in. Only let it crack from the wood, and it soon becomes needless. Late in autumn, if the weather is fine, I consider is the best time for all such work, as putty and paint dry more slowly, but more firmly, and without cracks.

As a rule, I wish every trade to keep to itself and to do its own work, and then generally the work will be better done. But in many places there is often much rough work of this kind, which, if done at all, must be done by the garden men at the most suitable time, and when the glass, however bad, cannot be spared in quantity sufficient to keep painters regularly at work. I lately saw, if something were not done, the winds and moving the sashes would throw out the glass from want of fastening. I have a lot of old sashes that have been useful for many years for laying over earth pits, and which I was allowed to keep on the clear understanding that they were never to involve a glazier's or a painter's bill. In doing similar work

I had this great advantage over tradesmen, that my men could work out of doors only when the weather was suitable, though I had taken the precaution to have many of the worst sashes washed and brought under cover before the rains came on.

Many people think that anybody can handle a putty knife or a paint-brush, just as they imagine that anyone can without trouble master all the details of gardening. There are others who wish to help themselves and yet feel no such confidence, and to them the following simple practical details may be useful.

Before painting it is important that glass and woodwork should be clean, even if a good washing should be necessary. In replacing even a square or two of broken glass, the old putty should be cleanly cut out, and a little thin paint run along the rest of the sashbar before the putty is bedded, allowing the paint to dry a little. With regard to moveable sashes in bad order, where the putty has mostly perished, it is often not possible to wash both sides of the glass without the squares falling out and being broken. It is then best to clear away all the loose putty, take out all the glass thus loose, wash it in a pail, and set it to dry. Wash the sash then, cut out all the putty at all gone, leaving only what is hard and firm, and when the wood is dry run a paint-brush along the sides of the bare, and in less than a day it will generally be fit for glazing. In all reglazing this thin coat of paint on the sides and rest of the sashbar is of great importance, as the putty is thus more firmly joined to the wood. This is often neglected. Even in glazing new sashes I would rather have the paint under instead of over-dried.

Then as to putty. The best is made of the best linseed oil and the best ground whiting, and the longer it is made, and turned, and sweated in a heap, the better it will be. For common purposes it is best to purchase it by the hundredweight. I prefer it stiff instead of soft. When it becomes rather stiff for working, it is better to beat it and work it well instead of adding more oil to it. When warmed by beating and kneading it works well and smoothly with the knife, and there is little or no sticking to the fingers, and, what is better, the putty sets well and dries more quickly and regularly than if softened with more oil. For certain purposes I have had a little white lead mixed with the putty; but though this makes it harder, there are two inconveniences attending it—first, it is more apt to crack than good wrought putty alone; and then, again, if you have to move it afterwards, there is much more trouble in hacking it out. A good labourer soon learns to place the putty well and leave it smooth with the putty-knife, whilst the base must never go beyond the rest for the glass on the sashbar.

The lasting of the putty greatly depends on giving it and the wood one or more coats of painting as soon as the putty is sufficiently dry. If there are many sashes to do, by the time the last is glazed the first will be ready to paint. This time two years ago I had a large job, and, if not done, I should have expected the glass to have been everywhere after a windy night. I could do no more than give one coat of paint over the putty, but for the two years it has seemed as sound as a piece of wood. Observing, however, a few small cracks the other day, I have just run a paint-brush over it after washing the sashbars down, and that will keep all sound and secure.

After several years the atmosphere robs the paint of its preservative virtues, and this is one reason why I advocate one coat a-year instead of several coats after the mischief is done. Then as to paint. Nothing is better than white lead and oil, though it is next to impossible to get white lead genuine. The whiter the paint the more lasting it will be, if the lead is near the mark; but the whiter it is the more easily is it sullied, and therefore it is often desirable to tone it down a little to a light stone colour. For outside work I think it is a good plan to use a portion of anticorrosion with the paint. I imagine it stands better than paint alone or anticorrosion alone. I should not advocate anticorrosion for inside work, or where the paint was to be subjected to much washing, as then lead paint is smoother, and stands the cloth or the brush better. For orchard-house work it would do either inside or outside. The very roughness outside makes it more enduring. It is thus less influenced by heat and cold than a smooth surface, just like a piece of rough-surfaced ground contrasted with one that is smooth and firm. A number of years ago I painted two posts with stone-coloured lead-oil paint in the usual way, but whilst one was wet I threw over it as much fine light-coloured sand as it would take on. In three years the painted post had the paint cracking and peeling; the sanded paint did not exhibit a flaw after four years, but looked more like stone than wood

Had I much to do with anticorrosion paint, from all I have seen and learned I would apply for Carson's anticorrosion, which is to be had of all shades of colour.

The very best paint I have seen for standing was made of zinc and oil. I have heard little of it of late. One thing against it was, it strained the wrists and arms of the painters in wielding the brush, as it worked so stiffly. The anticorrosion paint, even if good, is easily put on; but there is a precaution to be taken when it is used by itself or in conjunction with lead paint, and that is not to have too much in the paint-pot at a time, and to stir it frequently with a stick. For reasons assigned above, for clean dry walls and woodwork out of doors I would prefer anticorrosion to lead paint. I will add one more caution to the inexperienced as respects garden sashes, and that is to use a small brush for the putty part of the sashbars, and, if new, to tie it firmly across about 1 inch or less from the point, to prevent the paint going on the glass. Even with that care it will be well to have a soft rag to wipe off any little drop that may get there. Be very careful, especially with all lead paints, that none is allowed to get in and remain about the finger-nails.

Some of your readers may say, Why all this to-do about putting and painting, when, by using metal that cannot rust, and grooves or packing for glass, there will be no need for paint or putty? Why, indeed, if all who take a pride in their gardens, and would rather see their garden frames and sashes neat and serviceable, instead of little better than sieves, for keeping out water—if all such could at once adopt such new improvements. With every wish for improvements, a good many of us must make the best of very common, rather unsemitable materials; and if the best is made of them, the results are often anything but despicable. Sometime ago a great lover of Auriculas was sadly vexed that some of his best plants damped so in winter, though he had them near the glass in a nice two-light box, in which not a single square was broken, and air was given freely back and front. The squares, like a good many old-fashioned lights, were rather small, but that was not the cause of the mischief. Though the glass stood better than could be expected, the putty was nearly gone, and the rest loose at the sashbar, and at every drizzling rain or even very heavy dew there was drip all along the sashbars over the favourite plants beneath, one of those things of which the Auricula is particularly impatient. I could call to mind many instances where Pines have been spoiled and late Grapes damped from the drip from wasted putty; and whilst such glazing exists means must be taken to stop such dripping and secure the glass. I have omitted to say that moveable sashes can be best painted when off, two men to a sash, and the sash set up on its side, so that one side of the sashbars can all be painted, and then the under side of the sash placed at the top side, so as to paint the other side of the bars. The work can thus be done much more quickly.

Washing glass, woodwork, and walls is a great job with us in the end of October and the beginning of November. A little dullness of the glass is often desirable in summer where regular shading is not forthcoming. I use little shading but whitening put on for temporary purposes, as mere whitened water, or mixed with milk and size when I wish it to be more permanent. This whitening does no harm to paint or putty; but some use lime instead, and if that is at all quick it will injure both. All these, and all dullness and green spots in glass, it is desirable to get rid of before the dark days of winter are on us; then the glass cannot be too clean.

For outside washing I find nothing better than clear soft water, heated a little if the weather is cold. The same does very well, or weak soap water, for the inside of sashes in places where no artificial heat has been used, and where no insects have appeared. In the case of sashes over pits, frames, &c., or over houses, where we cannot move them, and where the least trace of green fly, thrips, or red spider has appeared during the summer, I like to syringe the whole well with water at about 180°, and if soap is dissolved in it at the rate of not more than 1 oz. to three or four gallons all the better. There is not a cranny in sashbars, rafters, stages, back walls, &c., but forms a good nest for the eggs of insects. Much of security from insects in a following year will depend on all these little crannies and openings receiving a good forcible washing of hot water. Water at that heat can be applied with the syringe, with the help of a thick cloth over the syringe, so that the left hand can hold it freely. Of course, however near it is, the water will be cooler before reaching the crannies and walls. At such a temperature deciduous fruit trees that have lost their

leaves may be washed or syringed, and thus eggs of insects, as well as the insects themselves, may be destroyed. In lean-to houses, brick back walls and plastered walls are great refuges for insects and their eggs, and such remain dormant until the advancing heat brings them into active vitality. It is better than nothing to limewash these walls every season; but it is much better to wash them well with hot water and to wash off the old whitewashing before putting on the new. The fresher the lime for this purpose the better it will answer. The whiteness of a back wall will in most cases be no drawback in winter, as the white surface will reflect the light. Where lime alone would be too glaring, it could be toned down a good deal with a mixture of sulphur. When the sashes are rather steep, so as to catch the rays of the winter and spring sun rather direct, and tender plants are grown near the apex of the roof, it may be desirable to tone down the colour there considerably more, by adding a portion of lamp black, or even fine root, to the limewash. In either case you will fail to make a good uniform wash unless you make the sulphur and the dark colour fine, and then with a small quantity of water beat each up into a paste before mixing with the limewash; then there will be no difficulty. Without such a simple process of wetting and making into a paste, you will be able to mix neither well so as to get a uniform homogeneous colouring.

Merely as a matter of precaution and prevention, I adopt the above systems of washing in almost every change of crop, in wooden frames or brick pits. Lately I planted out strong Cucumber plants in a brick pit, but before doing so, glass, woodwork, and walls, were well syringed with hot water before fresh limewashing the walls. In this pit a few green fly had appeared twice during the season, and early in spring some Strawberry plants near the apex had a few red spider. A little care now will often save much smoking and washing afterwards.

There is another preventive method I sometimes resort to, and that is burning sulphur in such pits and frames when empty; then it can do no harm, but care must be taken that the fumes find their way to no other place where plants of any kind are growing. Sulphur may also be burnt in houses of deciduous fruit trees, such as Vines and Peaches, when the wood is ripe and the leaves falling or removed, but with great caution, as if the wood is at all green—not thoroughly ripened—the sulphur will do great injury. Even these fumes, strong as they are, will not kill everything. I know of a small house thus smoked twice in order to destroy the mealy bug, but on taking up some shelves there the insects were quite jolly between the shelf and the bearers, though the interstices were large enough to let the sulphur vapour in. Exposing houses to frost would kill many insects, but I am not sure that the eggs would be destroyed, and I have known of some instances where mealy bug, notwithstanding its love for a high temperature, has, defended by its woolly coat, stood 10° below the freezing-point seemingly uninjured. I never knew it withstand water near the boiling point when forcibly applied.

At this dull season of the year much may be done by ensuring cleanliness, to act as a preventive against insects during the coming season, and thus labour and expense will alike be saved. In houses with earth floors an additional security is obtained by scraping away the surface, and sprinkling with hot water before surfacing with fresh soil.—R. FRIS.

BURR KNOT APPLES.

YOUR "CONSTANT READER," page 282, is right when he says that the Burr Knot Apple of the north is a good kitchen Apple, but wrong when he says that it does not resemble the English or any other Paradise stock, and he forgets, or does not know, that there is another Burr Knot, a still nearer relation of the Paradise, and which roots as freely from truncheons as its northern congener, which, I suppose, Dr Hogg did not think worthy of a place in a work upon select sorts, but he has in his "British Pomology" described both the Burr Knots.

I have obtained both kinds from suckers taken from stocks on which other sorts of Apple were grafted, and also several other varieties of so-called Paradise stocks; in fact, there are several sorts of Apple that resemble the Burr Knot and Oslin in their character, and that form roots from truncheons. Yet I may say that the rooting of Apples from cuttings is not a profitable way of procuring them. I have put in thousands by way of experiment, but have always had poor success with them in this way, and as far as I know, nurserymen generally prefer layering to trying cuttings. My own favourite Paradise

is, perhaps, the freest-rooting Apple known, and yet it does not pay to strike it from cuttings in the usual way, especially by trancheons. This last may be a good way for an amateur, but will not pay a nurseryman.—JOHN SCOTT, *Merriott Nurseries*.

OCTOBER CATERPILLARS.

Not all of the caterpillars which hibernate in our country continue to feed as long as leaves remain on the plants or trees to which they are attached. Some withdraw from their food quite early—that is to say, during September, be the weather what it may, and place themselves in the position which they intend to occupy until the face of Nature is again brightened with new foliage. Amongst these is the caterpillar of the elegant Geometer called the Grass Wave (*Aspilates strigillaria*), a species occurring on heaths in the south of England, and also in Ireland. The eggs are deposited by the parent moth, which is rather a rapid flyer, on or near the common Ling during July. The young caterpillars grow slowly and hibernate before winter arrives at the roots of their food-plant, feeding again in April. When touched or alarmed, this caterpillar falls from its position, and remains rigid as if dead. It is of a greyish-brown colour, varying in shade, with paler longitudinal stripes faintly marked. The whole body is covered with minute warts, which emit bristles; there are two humps on the ninth segment, and two of less size on the tenth; on the last segment there are two points, just above the anal claspers. The very handsome caterpillar of the Grey Mountain Carpet (*Larentia castata*) might be found young in October by those who are still making holiday in the north of England and in Scotland; and as the species is abundant where it occurs, the caterpillar should be more frequently found by observers; and the plant on which it feeds is not of difficult growth. At this time they are small; nor do they move until the spring, resting close to the roots of the Whortleberry or Bilberry; in April they reascend the twigs, but rest in the day with the head downwards. At night they turn round and feed, becoming soon mature. The body has a few small warts on each segment; the head is of an amber-brown, the general colour being reddish-brown or olive-green, the skin velvety; along the back there is a beautiful series of markings, arranged on seven of the segments, these are in the shape of the letter V, the point being towards the head; on the sides of this mark are four parallel lines on each segment; a fawn-coloured line runs through them all, the remainder of the V mark being filled up with rose colour; the lines are pale; there is a fold of the skin above the spiracles which is also pale. The legs are semi-transparent and pinkish. The cocoon is spun up amongst the twigs, and the moth comes forth at midsummer.

In October we find on the common Clematis (*Traveller's Joy*) the adult caterpillar of the Small Waved Umber (*Phibalapteryx vitalbata*). This rests, when not feeding, in a stick-like position, and might easily be passed by as an inanimate object; but if the plant be beaten into a net or umbrella, the caterpillar falls with the head bent downwards. The whole body is freckled over with warts, not apparently arranged in any method; the head is grey, with two small black spots on the mouth, and lines of the same colour on the cheeks; a narrow black stripe extends from the head to the tail, which is interrupted at each segment; the body generally is brown, getting paler towards the tail; along each side there is a wrinkled fold of the skin, lighter than the ground colour, and partially chequered with dark brown spots. This caterpillar becomes a chrysalis ere the winter sets in; and the moth, which appears in June, may be roused from the hedges by day if these be beaten near the food-plant, flying out usually with great rapidity. At night it visits the blossoms in search of honey. Abundant in some places, and scarce in others, is the moth known as the Clouded Magpie (*Abraxas ulmata*), and the caterpillar is to be found feeding until the end of autumn in woods on the yet remaining leaves of the Wych Elm. It is exceedingly torpid in its movements. Mr. Greene observes about its habits that "it does not appear to thrive in confinement. It seems to have the power of producing an almost unlimited quantity of silk. When disturbed it drops immediately. Give a tree where it occurs a tap with your stick, and down comes a whole shower of larvæ." The head and legs of this creature are deep black; down the centre of the back runs a black line, edged on each side by yellow. Beyond this is another broader stripe of black, then a white line, then another black line, and this again repeated. All these are distinctly defined. Just above the spiracles is a yellow

stripe, enclosing two black spots on each segment. The claspers and under surface of the body are dull yellow. The chrysalis is to be found sometimes by digging. Some of the small "looper" caterpillars, which produce the different species of moths commonly called the "Pugs," are yet feeding, and may even be found to the end of the month. All these caterpillars have a general resemblance to each other in their style of marking, though every species has its peculiarities, and the genus is also remarkable for the bright hues displayed on the chrysalis, especially as viewed by a moderate magnifying glass.

What is known as the Edinburgh Pug (*Eupithecia helvetica*), a species confined to Scotland, and unknown in England or Ireland, is produced from caterpillars which may be found full-fed about this time on the common Juniper. These individuals are rather short and "stumpy," of a grass-green colour, the dark line running down the centre of the back, which is tipped with purple; below this, on each side, are other lines of a deep green, sometimes edged with purple; just above the spiracles there is a wavy line of pale yellow; the head, which is slightly notched on the crown, is of a very deep purple. The moth is on the wing in May, and is very elegantly marked, surpassing many of its brethren in its display of colours. The caterpillar of the Pimpernel Pug (*Eupithecia pimpinellata*), dwells on the Burnet Saxifrage, making havoc of the flowers and seeds of this plant. There are two distinct varieties of this caterpillar, which, unlike the last, is long and slender. One form is green, with three purple lines, two of which are very faint; along the spiracles a yellowish line, the head and claspers being purple. Upon the back there are a few scattered tubercles. The other variety is of a general purple, with two lines almost black passing along each side of the body from head to tail. Mr. Crawe observes that these caterpillars seek those plants in preference which grow by the sides of hedges. He notes also that they are so infested with parasitic enemies that hardly one in ten attains its proper growth and becomes a chrysalis. This is placed beneath the surface of the earth. There appear to be two broods produced yearly.

The extraordinary caterpillar of the Lobster Moth (*Stauropus Fagi*), though not of very large proportions, may fairly take rank as the most singular in conformation of all British caterpillars known to collectors. The species derives its Latin name from the Beech, yet it seems more particularly connected with the Oak and Birch. It is rare, occurring only occasionally in the south of England, where sometimes an entomologist, taking a survey of the partially bare trees, chances to discover a "Lobster," grotesquely perched on some twig, and is in rapture with his prize, which dies, perhaps, on his hands thereafter, since caterpillar-breeding knows many mishaps. When reposing, this caterpillar throws back the head, and raises the front segments; the hinder part of the body is also raised, and bent towards the head. This is as large as the three segments behind it; each division of the segments shows very clearly, and from the fifth to the tenth there are two humps on each segment, decreasing in size towards the anal extremity; on the last segment there are two erect rigid horns. The first pair of legs are of average size, the second and third pair are of extraordinary length. The colour of the body is a dull brown; there is a very narrow pale stripe down the centre of the back, with a stripe on each side of it of a black hue; there are numerous points scattered over the surface, giving the caterpillar a shagreened appearance. Allied to this species, as also belonging to the family of the Cuspidates, is the Coxcomb Prominent (*Notodonta casmelina*) which feeds upon Oak, Birch, Nut, and other trees. It usually rests with the anal extremity raised from the surface of the twig or leaf, and if alarmed, will then throw back the head, and open its jaws, remaining in this position for some time. At the tail of this caterpillar are two warts or protuberances, with pink tips, and a little cluster of bristles proceeding from them, and there are scattered black bristles on other parts of the body. The ground colour is a pale green, almost white on each side of a stripe which passes down the back from the third segment to the extremity of the body, of a bluish tint, and slender. Near the spiracles there is a series of white spots; these are connected by a number of very faint lines. The legs and claspers are pinkish. The cocoon is spun upon the surface of the earth, composed of a little silk, mixed with particles of earth or dried leaves. A second brood of the Chinese Character (*Cilex spinula*), feeds upon the Hawthorn in most of our hedges in September and October. The caterpillar of the Pale Prominent (*Pilodontis palpalis*), which occurs full fed now on Willow, Sallow, and Poplar, unlike many of its brethren, has no humps or hairs.

The head is small, of a pale green; the body of the same colour, slightly rough with wrinkles; six slender stripes of white run from head to tail; on each side, above the spiracles, is a very distinct yellow stripe edged with black; on the second and third segments there is a little patch of lilac close to this stripe. The cocoon, from the locality where the caterpillar usually feeds, is often placed near the edge of some rivulet or pond, and the insect is careful to select a spot as dry as possible, and above the water-level, so as to be in less danger of being washed away in any overflow. Both the chrysalis and the caterpillar of the Pebble Hook-tip (*P. falcula*), may be detected on the Birch in October in various parts of England. These are individuals of the second brood, producing moths in May. The most remarkable circumstance connected with the appearance of this caterpillar is the variety of warts which are arranged along the back, some being small, others large and nipple-shaped; from each of these latter there arises a circle of short brown hairs, with a long bristle in the centre. The head is a greyish-green, with two bars on the crown. The body generally is pale green, with some purplish markings, part of these clustering so as to form a tolerably well-defined stripe down the back.

The caterpillars of certain of our Egger moths, which have to pass the winter in that preliminary stage, will occasionally feed through part of October, and may be seen, during high winds, crawling with great rapidity across a field or road, having been dislodged from their food-plant. The Oak Egger (*Lasiocampa Quercus*), is produced from a large caterpillar, which is about three-parts grown ere the close of autumn, and then ceases to feed until spring. The young caterpillar is brown, afterwards it becomes of a velvety black, though clothed thickly with brown hairs, which are of two lengths. There is a white mark, in the form of a crescent, on the side of the third and fourth segments; along the centre of the back there is an interrupted white line, and a similar one on each side. Unless much annoyed, the caterpillar of the Oak Egger does not roll itself into a ball. On heaths near London, and many other places, the caterpillar of the Fox Moth (*L. Rubi*) is found in autumn and spring; it is difficult to keep through the winter, unless it be placed on a sod dug from its habitat. This much resembles the preceding, but the hairs are more velvety, and of a rich brown; the sides appear entirely black. When forming its cocoon the hairs are freely stripped off, and mingled with silk; this is very loose, being 3 inches or 4 inches in length.—(*English Mechanic and World of Science.*)

PORTRAIT OF MR. RIVERS.

The following subscriptions to Mr. Rivers's portrait have been received. We again repeat that the whole of these subscriptions are forwarded voluntarily; and we trust that all who appreciate Mr. Rivers for the useful work he has done will not postpone sending their subscriptions in expectation of a direct application being made to them, as no such mode of solicitation will be resorted to.

	£	s.	d.
JOURNAL OF HORTICULTURE, Proprietors of	5	0	0
Fitzgerald, Mrs., Shalstone, Buckingham	1	1	0
Hole, Rev. S. Reynolds, Caunton Manor	5	0	0
Hooker, Dr. J. Dalton, C.B., Kew	2	2	0
Kingsley, Rev. W., South Kilvington	2	2	0
Morris, Mr. John, Wethersfield	1	1	0
Newington, Dr., Ticehurst	3	3	0
Paul, Mr. William, Waltham Cross	1	1	0
Pearson, Mr. John, Chilwell	1	1	0
Radclyffe, Rev. W. F., Okeford Fitzpaine	5	0	0
Rodeu, Dr., Kidderminster	2	2	0
Sparkes, George, Esq., Bromley	1	1	0
Speed, Mr. Thos., Chatsworth Gardens	1	1	0
Taylor, Mr. T. (Webber & Co.), Covent Garden	1	1	0
Wilson, Edward, Esq., Hayes, Bromley	2	2	0
Wilson, G. F., Esq., F.R.S., Heatherbank	2	2	0

Subscriptions addressed to Dr. Hogg, 99, St. George's Road, London, S.W., will be promptly acknowledged.

ROYAL HORTICULTURAL SOCIETY'S GARDENERS' EXAMINATIONS.

The following are the results of the gardeners' examinations on July 12th:—

1. G. Haskins, Royal Horticultural Society, Chiswick.—Third-class certificate with 700 marks in Fruit and Vegetable culture, and second-class with 830 marks in Floriculture.

2. C. Burley, Royal Horticultural Society, Chiswick.—Third-class certificate with 570 marks in Fruit and Vegetable culture, and second-class with 770 marks in Floriculture.

3. W. Mitchell, Royal Horticultural Society, Chiswick.—Not passed in Fruit and Vegetable culture, and second-class with 840 marks in Floriculture.

The examiner in Fruit and Vegetable culture remarks that "these were very unsatisfactory papers." The examiner in Floriculture remarks that "the best answers were those of No. 2, but fewer of the questions were replied to."

PEARS.

PERMIT me to make a few observations upon the three Pears described at page 284—viz., the BELLE ROUENNAISE, AVOCAT ALLARD, and HELIOTE DUNDAS. Of the first, it is said that it ripens in October. I have grown it for the last ten years, and have always found it ripen in August.

Of the second I enclose a tracing taken from a fruit which ripened here October 4th. The fruit this season is very small; last year it was twice the size, but I did not keep a tracing of it. Skin lemon yellow, much spotted and marbled with russet. Stalk about 1 inch long, set upright in continuation of the

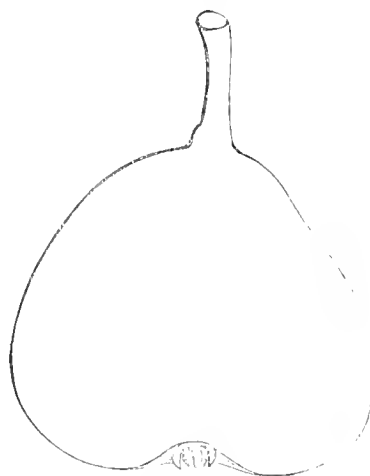

Avocat Allard.

fruit. Eye deeply sunk in an even basin. Flesh yellowish-white and melting. Juice very abundant, rich, spicy, and very delicious. I send you this description, as I have never seen one of it, excepting some slight remarks of M. Liron d'Airoles, in his "Liste Synonymique."

The third is Heliote Dundas. My note of this handsome fruit, made in 1869, says—delicious, rich, and buttery, but not over-juicy, ripe October 1st. This is a Belgian variety, said to have been raised by Van Mons, and it seems to have improved in this country, as in Belgium it is said to have breaking flesh, dry, and gritty, slightly sugary, and without flavour, with insufficient juice. 1869 and 1870 have been both warm seasons, and here it has been good, but in a cold or wet season it would be as it is in Belgium. It might be improved by planting against a wall.

I have just been tasting Doyenné du Comice from a Quince, and General Toddleben from a Pear stock, both are extra first-rate. The Doyenné from a Pear stock is as highly flavoured, but not half the size as from a Quince.—J. Scott, Merriott Nurseries.

AGARICUS PROCERUS.

I WAS lately at an hotel at Malvern, and finding in the garden a remarkably fine specimen of *Agaricus procerus*, I directed the waiter to have it cooked. In a short time he returned to inform me that it was poison; next, a message came from the French cook repeating the same tale; and before I could get it broiled, I had a third remonstrance. The number of my room was asked, so that if a body had been found there in the morning it would have been identified. I need not add that the fungus was delicious, and that, much to the astonishment

of the waiters, I survived the dish. I will not say, as Swift would have done—

"They'd rather have that I should die,
Than their predictions prove a lie."

But though I recommend my readers to eat Agaricus procerus when they are lucky enough to get hold of it, yet I do not recommend them to do so at an inn, for, on second thoughts, I did wrong in having the fungus cooked there. It might have happened that I was taken ill from some cause quite unconnected with the banquet, but the landlord would certainly have been accused by the public of having served up poisonous Mushrooms to a guest. Scandalous rumours find ready belief.

This autumn I have eaten with much pleasure Agaricus comatus in its young state, while the gills were still white—G. S.

FRUIT TREE NAMING.

IN the first notices to correspondents, page 251, the Editors prefer a well-grounded complaint. They had received, for the purpose of giving names, no less than three baskets of Apples, respectively containing twenty-nine, twenty-three, and seventeen sorts. Imagine a person sending twenty-nine Apples at one time! Who is to blame for such a proceeding? I most unhesitatingly affirm provincial nurserymen and gardeners. And why? many of them will be apt to exclaim. The following, I hope, will serve to show.

First, as to gardeners. When fruit trees are received from a nursery the tallies attached to them are of the slimmest description, being made of a narrow strip of wood tied to a stem or a branch by a small piece of string. The wood decays, the string rots, the tally disappears; it has dropped to the ground, and been either dug into the soil or raked off with the leaves and weeds to the rubbish heap: or, if by good fortune it may have been refastened, it has only been to escape its ultimate fate by a season, or to hang on the tree till it becomes undecipherable. Nurserymen's tallies ought to be regarded as merely temporary, to be replaced by a durable article at the earliest convenience. An excellent material is zinc, possessing lightness, cheapness, and durability. Let the name be written with indelible ink (say Yeats's), by a quill, and the label suspended from the tree by copper or lead wire, and it will last for generations. At the pruning or fruit-gathering seasons, a glance will show whether the wire is cutting the bark or not; then a minute or two, owing to the pliability of the wire, will suffice to rectify the matter; or, as recommended by Mr. Rivers, the names, in the case of wall trees, could be nailed to the walls, either above or beside the trees. I know one garden where this is practised; the names being on a level with the eye, and painted in letters sufficiently large that one passing along the walk can read at a glance.

Another method is occasionally adopted by some gardeners, but to it there are grave objections. The names of the trees are written in a book in the same order as they are planted, but the book is locked upon as private property, and the gardener when leaving the place takes the book with him. How, then, is his successor to learn the names of his Apples or Pears? for remember, pomological knowledge is not so very extensively disseminated that the general run of gardeners know a great variety of fruits. Either he must be obliged to his neighbours and thus betray his ignorance, or not wishing to remain in ignorance, and yet willing that his neighbours should consider him well posted in fruit lore, he sends a basket of sorts to the Editors of the "Journal."

One advantage of suspending the tallies is, that both head and under gardeners soon almost unconsciously acquire a knowledge of the sorts grown about the place. When nailing and pruning in winter and spring, they cannot but notice the differences among the sorts in habit of growth, sturdiness, weakness, short-jointedness, or otherwise of branch, &c.; also in summer, when weeding and raking the ground beside the trees, and pinching the shoots, they will have excellent opportunities for comparing the leaves and young shoots, and above all, the fruit will be an absorbing source of interest as it gradually approaches maturity. Now for a case in point. I called on a gardener of my acquaintance about three weeks ago to see a number of pyramidal Apple trees on the Paradise stock—a method of growing trees in which so many people are now becoming interested. Before seeing the trees he took me into his fruit room to show me their produce, which had been gathered a few days previously. Two sorts in particular struck my fancy, and, on asking the names, judge of my surprise when he

confessed he did not know them. This was the more reprehensible, as the trees were planted about three years ago, if not by his own hands, at least under his immediate superintendence. Had the names been suspended permanently from the trees, would I have gone without the desired information? I believe not. I am unable consequently to add trees of the same kind to my collection.

Now I come to the second part of the indictment, involving a certain class of nurserymen. The practice some of them adopt to obtain grafts of fruit trees is far from conducive to correct naming. The foreman, or even one of the under hands, as he can often be better spared, is dispatched to some gardening friend for a quantity of grafts. Whatever name is given is of course affixed to the young trees without much inquiry as to its correctness, nor is it difficult to understand that, in many instances, the name is only supposed to be correct, though in reality not so. Such trees when sold contribute to extend the evil complained of. Very few such nurserymen plant out a tree of each sort specially for fruiting, with an eye to prove the correctness of the nomenclature; and such sorts as do set fruit in the nursery quarters have the fruit taken off at an early stage, because, as say the nurserymen, "we require to grow wood, not fruit."

I was supplied early last spring with about twenty young Apple trees on the Paradise stock by a local nurseryman. Four of them fruited, of these one has proved to be wrong. If the same proportion of the others turn out incorrectly named, I will probably be under the necessity of troubling the Editors of the "Journal" to name some day a batch of five Apples. The above does not apply to the greater nurserymen, who, as a class, I am proud to say, would rather burn their trees than dispose of a single one which they are not certain to be correct to name.—A. R.

DALKEITH PALACE GARDENS.

Edinburgh, like London, has its suburban residences, not modern ones only, but also those of more ancient date, originally built for and occupied by the nobles, whose duty or interest called them to the metropolis; and the situations of many such residences are so judiciously chosen as to prove that good taste was by no means disregarded, but other considerations often determined the site. The turbulence of the times rendered it necessary to make every home of any pretensions a sort of fortress; and then inaccessible rocks, or sites by the coast or by the side of some stream that could be turned to good account to keep out an enemy, too often tempted the builder to disregard the position we now call beautiful, or what those of the last century would call useful; nevertheless, in some instances good sense did exercise its rights, and spots lovely in themselves, and commanding views of others equally so, were chosen as the sites of mansions or castles. In these cases the occupier at the present peaceful time has the advantage of inhabiting an historical place without the inconveniences such a residence often entails.

Dalkeith Palace, the noble seat of the Duke of Buccleuch, occupies a position near enough the northern metropolis to be of easy access before the days of McAdam, not to speak of his still more rapid-travelling successor George Stephenson, and is one of those massive piles of masonry which strike the beholder with respect more by their magnitude than by any especial merit in the style of architecture, although in this instance the latter is not without its claims to notice. Perhaps, however, the most remarkable feature is the fine site which the mansion occupies—sufficiently high to command a good view of the country without being so high as to be bleak. Higher ground is to be found in the rear, and the luxuriant trees around it give sufficient shelter; whilst perhaps the finest of the adjuncts is the river Esk, which flows past it, and is almost within a stone's throw of one of its fronts. The river, which I believe higher up is applied to some of the purposes of industry for which the town of Dalkeith is noted, flows through a park of great beauty and variety; and near the mansion its banks, especially those on the opposite side of the Palace, are sufficiently steep and picturesque, but they are richly clothed with foliage; and the general character of the district is smiling, and exhibits none of those rugged outlines which, however beautiful in a bright summer's day, convey but dreary notions of comfort in midwinter. The Esk at this particular place passes through a fine undulating country, and in its course through the park adds materially to the general effect. A bridge over the river at a short distance from the Palace looks

remarkably well, and gives access to the grounds on the opposite side, on which the gardens, the subject of the present paper, are placed. A carriage road from the highway and town of Dalkeith leads in another direction, while surrounding the noble pile grounds are judiciously laid out in that style of natural esse becoming a place where so much of rural comfort is united. No cutting up the lawn into petty insignificant flower beds, where the occupants could be easily guessed at as so many dozen, but large open spaces, intersected by corresponding masses of shrubs and trees, the whole being remarkably well kept. One side of the grounds slopes down to the river by a natural and agreeable incline of 50 or 80 feet; while on the opposite side is the carriage entrance and a fine lawn, sufficiently extensive to exercise a battalion of infantry, yet it is machine-mowed. Some fine trees form the boundary of this open lawn, and join with others flanking the river. Turning one's eyes in another direction one sees still nobler trees clothing the opposite bank of the river; and as the garden is in that direction, I crossed by the bridge and passed along the walk which intersects the woody ravine, noticing here and there Oaks and Silver Firs towering above shrubs of various kinds, which have been planted to assist the undergrowth, while on the rocky eminences grow Ferns and other graceful plants. On ascending the hill, after a walk of some distance, one finds himself in the vicinity of the gardens, whence Mr. William Thomson has at various times sent forth such examples of skill; and from what I saw, there seems to be no reason to expect that such will cease.

Large, noble, and exceedingly well managed as the garden is, there is one thing wanting to give it that imposing appearance which it ought to have, and that is a suitable approach—an approach which would convey to the beholder an adequate idea of its vastness. I know it is impossible to have such an approach from the nature of the ground, and it is also a fault to be found in most gardens. There are few places where the kitchen garden and forcing department have a sufficient air of dignity and compactness, the cause of this too often being that the place has been added to from time to time, and an incongruous whole is the result. Perhaps one of the best examples of a contrary description is the garden at Belvoir Castle, Leicestershire. But it must not for one moment be supposed that I say the garden at Dalkeith presents a want of uniformity or design; on the contrary, it is in this respect one of the best I know, but being placed somewhat high, and there being no higher ground commanding it, the various ranges of houses and pits, and the brilliant flower borders and other fine adjuncts, could not at one view give an idea of the grandeur which it actually possesses. I will, therefore, take it in detail, and whilst surprised at its treasures, perhaps one cannot regret being unable to see the outline of the whole at once.

I have said the character of the country about Dalkeith is somewhat hilly, and the kitchen garden and its appurtenances, including, by-the-by, a large space of dressed ground, occupy a plot of table-land or terrace, the garden part being level, or nearly so. The principal kitchen garden, a parallelogram, is situated about the centre of this plateau, while to the north there

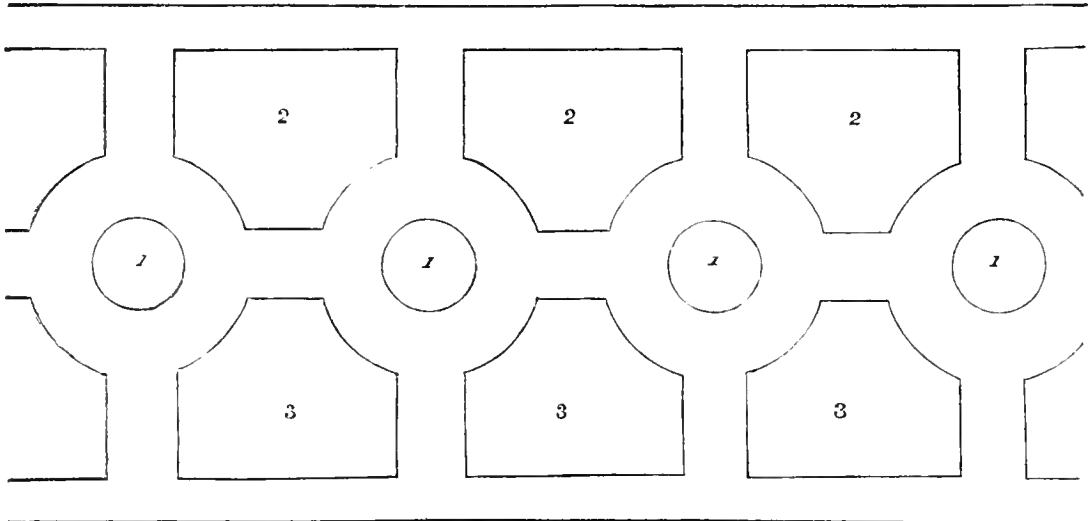

Fig. 1.

1, *Lobelia speciosa*, with a single plant of *Centaurea candidissima* in the centre.

2, scarlet *Geranium*.

3, *Gazania splendens*, with an edging of *Cerastium* on the straight side next the main walk.

is a similar space nearly as large, almost entirely covered with glass structures. Another garden, with glass against the south wall, was southwards of the main kitchen garden, and to the south, again, a Rose arbour divided this plot from a lawn occupied by some thriving Conifers. Still farther to the south, and on what may be called the edge of the terrace sloping to the south, was an orchard of mixed fruits, while a large plot of kitchen garden extended along the west side of the whole, enriched with tastefully-arranged flower borders; and on the east, which may be called the approach side, a large extent of lawn extended over the edge of the hill facing the river, and communicated with circuitous walks leading to the Palace. The whole may be summed up as comprising three or four parallelograms of equal length adjoining each other, with their long sides to the south, their surroundings on the west and south sides being kitchen garden, reserve ground, and orchard; while on the east side is a large plot of dressed ground, with flower borders, &c., the lawn extending a considerable distance down the hill until it meets the wood fringing the river Esk. Taking, therefore, these compartments in rotation, I will begin with the northern one, which, as stated above, is mostly covered with glass.

In a garden so renowned for its forcing it may be supposed

that an extensive area of glass is devoted to each particular purpose, and that nothing in the way of crowding would occur; but I have no doubt that those who have the privilege of seeing these houses in winter or early in spring will see every inch of them as full as smaller houses usually are. Of course, in the fine hot weather of the early part of September only the permanent occupants of these houses were in their places, with the exception of things that were being prepared for other purposes, and these were numerous enough. But it is better to describe the outline of the houses first, and then their contents. Unfortunately I did not take such careful notes as I ought to have done, but I may remark that in general the houses were large, or rather long, and being arranged not unlike the streets of a town newly laid-out, their appearance from the high ground to the south-west was imposing, some lean-to vineries occupying the north wall, with a central house of another description undergoing alteration at the time I was there; while on the south side of these was a row of Pine pits, or rather houses, for there was a path inside of them. These pits had a short north light over the pathway, as will be described hereafter. Another row of pits of the ordinary description ran in front of them; then again another tier of lean-to houses, lower than the back ones, and another row of pits, the whole presenting a

mass of glass rarely to be met with. I may add that there was ample space for the Vine borders, paths, and other requirements, and that all was in good order, and well arranged.

As it is unnecessary to describe the contents of each house individually, an outline of some of the most important may be given. I will first take a late vinery, 110 feet long by 11 feet wide, with a high back wall, giving, consequently, a steep roof, which Mr. Thomson regards as the best for a late house, as insuring greater dryness than roofs of lower pitch. A large portion of it was planted with Lady Downe's Grape in most excellent condition, the berries large and well swelled out, and the bunches compact. West's St. Peter's was also good, though not so promising as Lady Downe's. A large white Grape, not much grown in England, also looked well. Its name is Calabrian Raisin, and it partakes somewhat of the character of the Syrian. There were several examples of it at the Edinburgh International Show, and its merits as a late-keeping Grape were much spoken of. I did not recollect seeing the Alicante, but undoubtedly it was there. Mr. Thomson had also some novelties in this house, of which I trust to hear something hereafter. Among them were some seedlings of great promise, one especially of that peculiar rich flavour so much sought after, and another promised to attain an unusual size. Other Grapes of well-known kinds were also grown, and all were good.

In another house of still larger dimensions than the last-named were very good Muscates, well ripened and finished off,

although the Vines had only been planted about twenty months, both the house and borders having been renewed. In this house most of the varieties of Muscates were to be seen, with other novelties, but the sort respecting which most likely inquiries will be made is Duchess of Buccleuch, which, as your readers are aware, is a white Grape. There has been some difference of opinion regarding it, but having seen it at Archerfield and Floors Castle, as well as at Dalkeith, I may safely say much that has been said against it is wrong. True it is not a showy Grape, and I hardly expect it will be a favourite on the exhibition-table, but for the dessert, I am told, it stands pre-eminent, being regarded superior to the Muscat, and in the opinion of some gardeners of high standing, who, like myself, tasted them both at the same time, the palm of merit on the score of flavour was due to the Duchess, which seemed to have more of that rich musky flavour which Chasselas Musqué when at its best possesses; at the same time it has all the firmness of flesh of the Muscat. The Vine, too, seemed to bear well. The bunches were medium-sized, and what I saw were compact, showing that few or no berries had been cut out after the usual thinning time. I cannot agree with those who find fault with it for cracking, for I did not see any berries disposed to do so. Some writers, I believe, have found fault with it on that account, and attributed the cracking to damp, but at Dalkeith a Vine of it in full bearing was pointed out to me growing over an open tank of water, and in as good condition as any other. It will, however, I trust be accurately

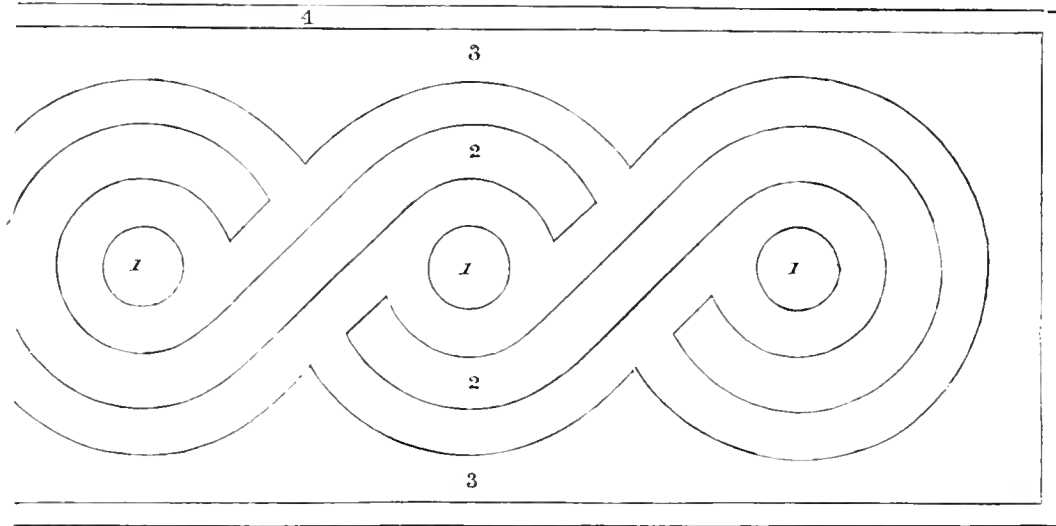

Fig. 2.

- 1, Calceolaria canariensis.
- 2, Lobelia speciosa.

- 3, Cerastium.
- 4, Single row of Geranium Brilliant next the grass edge.

tested another year in many places, and I have no doubt that it will have a host of admirers at a private table.

The central house of this line was undergoing some alterations at the time of my visit, and I believe it was intended for plants, and to present an ornamental front as becomes the central structure of a mass of crystal. There were, I believe, some other vineries against the back wall, as well as the two above described, but my notes are imperfect on this point; suffice it to say that the central house was intended to be a noble one, and the pits and other houses in front of it were cut through, so as to allow a wide pathway to approach this house, dividing the four rows of pits and houses in front of it into eight shorter ones. The next line to the back one was a span-roofed Pine pit or house on one side, and on the other a similar pit that might be used as a Pine pit at any time, but was employed as a plant house, and a great quantity of Geraniums were being prepared for winter flowering. This span-roofed house was 180 feet long by 13 feet wide.

Corresponding with the last-named range were the Pine pits or houses, 200 feet long by 13 feet wide, divided into three compartments. There was a short north light covering the pathway, with two pipes at the back, two in the front of the pit, and two underneath it. Tan was also used as a heating material. Some most excellent Pines were grown here. Several Smooth-leaved Cayennes were pointed out to me that were

expected to weigh 8 lbs. each, and some of 9 lbs. and upwards had been cut. This variety seems to be remarkably well grown at Dalkeith, as well as at Archerfield, and appears to be the favourite in Scotland, just as the Jamaica is at Manchester, and the Queen around London. Certainly I never saw such fine fruit of this variety in the south, and my impression was, that the Scotch Smooth Cayenne is a superior variety or is better managed. There were Queens also; a very good one upwards of 5 lbs. in weight had been cut just prior to my visit, and there were others in all stages of growth. Mr. Thomson likes them best in pots, but has tried the planting-out principle as well. These houses were all filled with fruiting Pines; succession ones were grown in some lean-to pits in front of those just described, and were all that could be desired.

In front of the fruiting Pine house, but separated from it by a broad path, there is a low lean-to pit, which although used as a cold pit at the time of my visit (September) is, nevertheless, furnished with hot-water piping for use in winter; and one compartment of about 100 feet long by 6 feet wide was filled with bedding Geranium cuttings, not in pots or boxes, but platted in the ground, and I understood they wintered very well there, heat being used when required, and in March they were taken up with balls and potted-off singly. The number of cuttings such a pit will hold gives some idea of the requirements of the place. At the time of my visit they

were fully exposed night and day, and I expect would be so until cold nights set in. The pit was a low one, and I believe a portion of it was used for wintering Strawberry plants for forcing, but a portion of it, 50 feet or more long by 6 feet wide, was filled with a fine collection of Alpine plants in pots, which I daresay were intended for some other place, but even where they were they were very interesting, all being carefully named, and many novelties amongst them. I was glad to see Mr. Thomson patronising this class of plants, which to my idea are quite as interesting as many fashionable stove plants; but, no doubt, they will have their day when the rage for colouring fades away.

In front of the pit last described is a set of Peach houses. One of these, 200 feet long by 8 feet wide, was more lofty than usual, there being a low front light as well as a short top one slightly leaning to the south as well as the main rafter, which was more upright than in the generality of houses. There were trees both against the back wall and also under the glass in front. I was told excellent crops had been gathered, and the appearance of the trees promised well for another year. There was an Apricot house adjoining, with trees trained against the back wall and others in front in pots, so as to give as much light as possible to the back, where the bulk of the crop was expected. The pits in front were devoted to Melons, Cucumbers, and the like, the whole being heated by hot water; and such crops as Capsicums were luxuriating in some of the compartments, but I had not the opportunity to notice all.

My limits forbid anything but a hasty glance at the kitchen garden proper, which is at Dalkeith made more ornamental than at most places of a like kind, but the crops of vegetables seemed to be good and abundant, and the Peach trees on the walls well covered with fruit. Broad walks divided the kitchen garden into compartments, and wide borders of the most popular hedding plants margined these walks. These borders, and others outside of the garden proper facing the east wall that bounds all the compartments named, form the principal flower garden at Dalkeith; and when we are told that 60,000 bedding plants are turned out every season, it will easily be conceived that these are very large. A border in front of one of the hothouses—not a vinery or Peach house, for such borders are held sacred, but an ordinary forcing house—had a suitable path in front of it, and then a neatly trimmed Box hedge, in front of which was a row of a scarlet Geranium of tall growth; next a row of Geranium Alma, silver-edged; then a broad band about 4 feet wide of Lobelia, with single plants of Centaurea candidissima at about 10 feet apart in the centre; and in front of this band of Lobelia was a Cerastium edging adjoining the permanent Box edging of a principal walk. This border, 400 feet long, looked remarkably well. Another border of the same length on the other side was somewhat differently planted, a band of Gazania being substituted for the Lobelia, with dots of Centaurea 10 feet apart. This border was 12 feet wide, and one of its lines consisted of Calceolaria Aurantia, which was said to be the best used at Dalkeith.

Some of these borders were divided by Box edgings and narrow gravelled walks into pleasing running patterns, of two of which I give designs. One of these is in front of a Peach house, but an ample space from it is allowed for the roots of the trees to have full scope. The portion required for the ornamental border was 14 feet wide and upwards of 400 feet long, and it was edged with Box, and planted as in *fig. 1*.

On the opposite side to this running pattern was a ribbon pattern, planted somewhat in the same style as others previously given—viz., the edging next the main walk (inside the Box) Cerastium, then a band 4 feet wide of Purple King with patches of yellow Calceolaria at every 10 feet, then a white-variegated Geranium in double row, and finally a tall scarlet Geranium at the back. This looked very well.

Another border of a running pattern in Box (*fig. 2*), formed an edging to the broad walk that ran along the side of the high wall separating the kitchen garden and forcing department from the lawn or dressed ground that descended to the river, or rather to the wood that fringed the river. This border—450 feet long—was in what I have been accustomed to call the Florentine chain, but I am not sure if that be the proper term; *fig. 2* will, however, explain it.

The above adjoin a large piece of closely-shaven turf but little broken by shrubs, and sloping to the eastward. On the other side of the walk is the wall alluded to, covered with climbing Roses and other ornamental plants, with a ribbon border in front of it planted thus, beginning at the walk:—1, Verbena Miss Hamilton, scarlet; 2, Band of Alyssum varie-

gatum 3 feet wide, dotted with a scarlet Geranium at every 10 feet; 3, Verbena Purple King; 4, Calceolaria, yellow; 5, Geranium, scarlet, tall variety.

Amongst other features of this fine place was an arched Rose arcade, bordering the space set apart for a pinetum. This arcade, like most of the borders described, was 450 feet long. An arched wire frame of suitable height and width was well covered with climbing Roses, and at the proper season no doubt looked well. Beyond that, Wellingtonias, Ratinosporas, Thujas, and other Pinuses were well represented. Other borders were worthy of notice, but sufficient is given to show the extensive scale on which this work is carried on at Dalkeith, the whole being so well done that the most fastidious would have a difficulty in suggesting an improvement; while the urbanity and kindness on the part of Mr. Thomson in showing the writer and his friend everything connected with this fine place, at a time, too, when so many other pressing matters might have called him away, ought not to be passed over without a due acknowledgement. Dalkeith and its gardens will always be thought of as one of the sights which come far and few between, but the fame of the place is already sufficiently known to require no further comment, as its reputation may be said to be European, if not more than that.—A CORRESPONDENT.

[This communication ought to have appeared long ago, and possibly some alterations may have taken place in this important garden, but we believe the main features are the same.—Eds.]

THE VEITCH MEMORIAL.

A GENERAL meeting of the subscribers to Mr. Veitch's memorial was held at South Kensington on the 21st inst., James Bateman, Esq., F.R.S., in the chair.

From the report, which was read by Mr. Moors, it appeared that the total sum raised is £1012 12s. 9d., from which, after deducting the necessary expenses, there remains the respectable amount of £890 18s. 4d., which will be invested in the names of trustees, and the annual interest arising therefrom will be devoted to the awarding of prizes for the advancement of horticulture in the three kingdoms.

An admirable full-length portrait of Mr. Veitch was presented to the trustees by Robert Crawshaw, Esq., of Cyfartha Castle, and is at present suspended in the Council-room of the Royal Horticultural Society.

It was moved by Mr. John Fraser, seconded by Mr. D. Wooster, and agreed to *nemine dissentiente*—"That the report of the Central Committee be adopted, and that the said Committee be hereby empowered to carry out the recommendations of the said report."

It was further proposed by Dr. Hogg, and seconded by Mr. J. Gibson, and also adopted unanimously—"That the thanks of this meeting be conveyed to Robert Crawshaw, Esq., for his gift of a portrait of the late Mr. James Veitch, in furtherance of the Veitch memorial."

On the motion of G. F. Wilson, Esq., seconded by Mr. Lamb, it was agreed that a cordial vote of thanks be given to the Chairman for his kindness in presiding on the occasion.

The trustees appointed are Mr. G. F. Wilson and Mr. Thomas Moore, the Treasurer and Secretary to the fund, Mr. Harry J. Veitch, Dr. Robert Hogg, and Mr. Zadok Stevens, representing England; Mr. William Thomson, representing Scotland; and Dr. David Moore, representing Ireland.

WORK FOR THE WEEK.

KITCHEN GARDEN.

It is time to think of forcing a little *Asparagus* for early use. The principles applied to the forcing of Sea-kale are in the main applicable to this delicious vegetable, except that *Asparagus* requires an abundance of air when growing through the soil. Prepare a plot of ground, by thorough digging and manuring, for a few *Mazagan Beans*. Let the *Beet* and *Carrots* be taken up and stored away directly. It is a good plan to completely cut off the heads of the *Carrots* below the neck, thus checking their tendency to grow. A few *Parsnips* for present use may be taken up; they wilt, however, keep well in the ground, and thus circumstanced they may have a coat of manure spread over them for the next crop, and be tramped out as wanted. For the earliest *Peas* prepare a piece of ground as recommended for Beans.

FRUIT GARDEN.

Planting, pruning, training, trenching, &c., are matters that

belong peculiarly to this dormant period, and having before disposed of planting and trenching by directing attention to their importance, I will now offer a few remarks on pruning. The habits of fruit trees vary, more especially as to the manner of forming and exhibiting their buds. There is no difficulty in distinguishing the fruit-bearing portions of the Apple, or of bush fruits in general, whilst the Apricot and the Filbert are at this period somewhat obscure in regard to this point. Even in the Pear, more especially some of the kinds, such as the Passe Colmar, the Seckle, the Marie Louise, and some others, it is difficult to prune with safety in the early part of winter. For these reasons prune bush fruit the moment you can find time. Follow closely with Cherries, Plums, and Apples, and towards Christmas lay aside the knife until early in February, when the Filberts will be blooming; then after a slight thinning of the crowded and inside spray, male catkins may be brought, if requisite, and suspended amongst the bushes. The Apricots will, by this time, give unequivocal signs by which to know the true blossom-buds, and may immediately receive their pruning. The Peach and Nectarine will succeed the Apricot, and may be followed by the Pear, and lastly by the Fig. In pruning bush fruit, thin liberally. Let no two branches of the Black Currant and the Gooseberry touch when finally thinned; these seldom require shortening; an equal and judicious thinning is, therefore, everything here. In pruning Apples, the thinning of the branches or old wood should be the first step; this, however, requires caution. Mr. Knight, of Downton, was much opposed to cutting out large limbs, unless an urgent necessity existed. His authority is too weighty to be passed over easily, more especially as he lived most of his time in a cider district. In thinning the young wood of espalier trees, remember that the first point is to secure a continuance of leading shoots to form a compact tree, and the second, to secure a free admission of light to all parts of the tree. The same remarks will apply to the pruning of all the rough espaliers or dwarf standards of any kind in the kitchen garden. Raspberries may now be planted and pruned.

FLOWER GARDEN.

Plant all autumn bulbs without delay. Let all biennials be planted out soon. Such plants as the Sweet William, Wall-flower, Canterbury Bell, &c., are of great use in flower borders, and may be planted three or four in a mass. Dahlias should be marked forthwith. Pinks may be planted out, and Carnation layers or pipings may still be potted to place in frames. Ornamental climbers on trellises, &c., in blossom should have a protection on nights of a frosty character. Much valuable late blossom may sometimes be insured by such simple means, as it not unfrequently happens that after one or two severe nights the weather becomes mild for weeks.

GREENHOUSE AND CONSERVATORY.

The period has now arrived in which the increasing scarcity of flowers in the decaying parterre should be compensated for by those conservatory flowers peculiar to winter, and by retarded summer flowers. These together, under good management, will lead us imperceptibly up to the products of the forcing pit, which form a distinct section, and, of course, require a separate course of treatment. The Camellias will form most prominent objects in the conservatory for the next six months, and those which have been managed for forcing, as it is commonly called, according to previous directions, will be in full gait from this period till Christmas. Such plants should now have weak and clear liquid manure, and a temperature of from 50° to 55°, descending at night to 45° in dark weather. A very considerable amount of atmospheric moisture should be afforded them; drip, however, must by all means be avoided, and the syringe is not to be used. The Chrysanthemums may be treated with manure water constantly, and all suckers and waste shoots trimmed away. Early Cinerarias should now be coming into blossom, and, above all, the tribes for winter flowering; these require all the light which the season affords. They should be kept close to the front glass until in blossom, be frequently syringed in a light way, and if the shelf is warmed by means of a flue or pipe beneath, so much the better. The Chinese Primrose will do in a more shady situation; spring plants sown last March will bloom freely now under ordinary circumstances; they do not endure dry heat. The Hybrid Roses, as before observed, will enjoy a similar treatment to the Chrysanthemums, whilst the Tea Roses will class better with plants of intermediate character, requiring a little more warmth with a permanency of atmospheric moisture. Such are the Euphorbia jacquiniiflora, Gesnera zebrina, Achimenes picta, Gesnera ob-

longata, Linum trigynnum, Plumbago rosea, Begonias, &c., all of which should have a temperature of 60° by day, rising to 80° by sunshine, and sinking to 50° at night. The above are all most useful and interesting flowers for the dead of winter; so are some of Mr. Fortune's Chinese plants, such as Abelia rupestris, Azalea squamata, Jasminum nudiflorum, and Weigela rosea; the last, a most admirable forcing shrub, can be brought into flower when very small for drawing-room purposes. Where everything is grown in one house it is of the utmost importance that there should be a proper relation between the amount of heat and light. In such a house the proprietor naturally desires to have flowers late as well as early, as far as such can be carried out. To effect this fires must be in use occasionally, even at this period, and those who are thus circumstanced, I would advise to beware of night heat; 55° will be sufficient in such a structure for the present. Let the thermometer rise to 70° or more during sun-shine, observing if such is fitful to drop it to 60° in the day, if dull weather takes place.

PITS AND FRAMES.

See that the Mignonette has a very light situation, and is plunged close to the glass at the back of the frame free from drip. Store Verbenas growing rapidly should have their tops pinched, also Petunias, and other ordinary mass flowers. Give all the air possible.—W. KEANE.

DOINGS OF THE LAST WEEK.

The heavy rains have made us independent of the water-cart for a time, and we are reaping the benefits of increased spouting. The rain has interfered with cleaning and repairing sashes for the winter, but many of the sashes being dry in sheds, work could be done there when it could not be carried on out of doors. For brick pits sound wall-plates are of great importance, as we have often found to our cost that rats which could enter in no other way soon made a hole through the wall-plate when it was decaying. Many a score of young plants have we had eaten-over in winter from this cause alone. Last year, from this cause, our young Calceolarias suffered from rats and mice, and singularly enough, though Aurea floribunda was pricked out as cuttings in several places a good way apart, they were singled out to be nipped close to the ground. We have strong wall-plates put on, ready for shortly commencing with Calceolaria cuttings, as the later they are put in the better, generally, do they thrive with us, if we can get them in before frost to any extent attacks them. With us little as yet has suffered except the Colera, though everything looks washed in the flower beds now, and even the Calceolarias, which have stood well all the season, have now few fresh flowers left.

Our routine has been so much the same as in previous weeks, that we will say a few words on some matters that have taken up a considerable portion of our time.

Insect Enemies.—Much may be done now in the way of prevention, as has been elsewhere alluded to, and what is done now will save labour and expense in the following spring and summer. We have much need to depend on cleanliness and modes of prevention, as there are many subjects that we could not syringe overhead with our water in summer, or at any time when fruit was approaching maturity. We have rarely been able to syringe Vines after they were in full leaf. Cucumbers and the like we syringe, because the older leaves are gradually removed as younger growth takes their place. Even our soft water in tanks is apt to leave a sediment on leaves syringed. With preventive measures we have generally escaped without being much troubled with insects, so that we have not been able to try to a great extent the many remedies that were to kill all such vermin as if by a miracle, and not hurt the most tender plant. We believe that Gishurst, the various powders, insecticides, Messrs. Veitch's mixture for bugs, &c., and the different combinations of tobacco paper and tissue, are all good, and so far effectual, if the vendors would not speak so enthusiastically about them, and if people were not thus led to believe that each and all were to effect such wonders as to stand in the place of timely application and unremitting attention. As often stated, when plants are covered with insects, remedies are of little use, as what would kill the insects full-grown, will not kill the young ones, and what would kill all that are alive will not touch those not hatched but ready to be so. Failure often arise, too, from not attending to the directions given. Too strong a dose will be too much for plants as well as insects. It is better to repeat the dose than to have it over-strong.

For *red spider* we have found nothing more disliked than a moist atmosphere with the smell of sulphur fumes in it. For *green fly*, where washing overhead cannot be given, we have found nothing better than tobacco-smoking, and the best tobacco is the best material, if motives of economy do not render it advisable to use tobacco paper instead. We find Griffiths's tobacco paper very safe, and we considered it best until we used that sent out by Mr. Appleby along with his fumigator, which may be described as a three-footed kettle with holes in the bottom and holes in its lid. We have never found such effects on green fly produced by such a small quantity of material. The direction must be attended to—not to stop in the place after the tobacco is fairly lighted, and it burns so slowly and surely that there is no necessity for doing so. For general purposes, for keeping insects away and disposing of them when they come, and when we can use liquid, our mainstay is weak soft-soap water.

Of all intruders we think the *mealy bug* about the worst to get rid of, for it lodges in so many nooks and crannies. Until lately we have had no trouble with this pest for a great many years. We believe it came to us about the time the new varieties of *Coleus* were first brought out, and we fear we shall have some trouble with it before we free ourselves of it. We have some Figs that were first turned out of pots into a low pit as bush plants, and that have borne very well for many years. Partly from carelessness, these plants had little done to them in the way of cleaning for two or three years, as they did not seem to require it. This summer the stems are infested with scale, and what is inconceivably worse, through some fine *Coleuses* standing at one end, they are also attacked with the bug. The withering leaves were taken off and burned; the plants have been syringed several times with soft-soap water at about 170°, as we were afraid to use it warmer in case we should hurt the young Figs showing like small pinheads. The stems and shoots were washed with cloths and a brush. Every moveable board was removed and washed, and all the walls, woodwork, &c., thoroughly syringed with the hot soap water, and then well scrubbed down before being fresh limewashed. The surface soil of the bed after all this washing was carefully scraped off to the depth at least of 2 inches. If we could spare the house as long we would wait for frost to nip the trees a little before we painted them over with some suitable mixture. The main shoots and stems had been painted with lime and Gishurst three years ago, and wherever that remained there was no scale. After the washing, when we syringed again with the hot water, we could see it brought out some small bugs from their holes and crannies. We hope we shall thus get rid of the enemy, using a sharp look-out, as of all insects it is the most obnoxious to us, though we have had little to do with it since our young days.

Of this we are sure, that however and with whatever mixture, dangerous or otherwise, plants may be cleaned, if the cleaning is confined to them this insect will never be eradicated from a house where it has once gained an entrance. It will find a home in every hole and cranny of sashes, stages, shelves, and walls, and unless dislodged or shut up, there it will remain until it makes a feeding ground of the plants. The thorough cleaning of houses as well as plants is all the more important, as this insect is so easily carried from house to house. We believe that very often, quite inadvertently, workmen take the insect on their clothes from house to house. Notwithstanding all this care, for which the wet days gave a good opportunity, we shall keep an extra look-out on these Fig trees next season. For the scale, we feel confident that will be destroyed. We do not feel quite so certain about the mealy bug, as a few might escape the washing and the smearing of the shoots. But for the scale appearing, we had made up our mind to dispense with the unnatural system of smearing the stems, and be satisfied in the case of deciduous plants with giving a good washing. The smearing can only be useful as a means of shutting up all small insects, and keeping smaller eggs from the air, so that if hatched the young have no chance to breathe. For this purpose, as the simplest means, perhaps nothing is more effectual than clay paint with or without a little soft soap in it.

Numerous remedies have been proposed for *American blight* on Apple trees, an insect which in its woolly clothing much resembles the mealy bug. Among them are washes, turpentine, oil, tar, &c., more or less prejudicial to the trees, as well as to the insects, but we have never seen anything more effectual than a good washing with warm water when the leaves fall, followed by covering all over with clay paint, or a mixture of clay and lime, and even limewashing itself. Towards spring,

if there was a crack or two, or the insects appeared at any crack or hole, there was needed but a fresh daubing. Once we had some standards 20 feet in height very much infested with the insect. These, after the fall of the leaf, were syringed with the nozzle end of the syringe, using rather thick limewash, and had the dose repeated at midwinter, and once again as the buds were swelling in spring, and no more American blight appeared. With low pyramids or bush standards the brush might have been used, but even in their case the wash applied with the syringe, so as to trickle into every cranny, is generally effective. Some time ago we had the American blight on some bush Apple trees, but after using limewash with some soot and clay in it in spring, to deter the birds from picking the fruit buds, the insect disappeared. At other times, when the insect appeared just here and there, we have known it destroyed by daubing up the places with thickish clay paint, and if this cracked, so as to let some air in, the operation was repeated. On the whole, then, for enclosing eggs and small insects, we question if there is anything much better and simpler than clay; anything nasty, but harmless to vegetation, might make it a little more effectual.

In the case of *scale* on growing plants, we consider all mixtures in which turpentine or strong acids form a part to be dangerous to plants as well as insects. Strongish soap water, glue water, &c., are useful, to be followed with hard syringings with heated water, say 120°, in twenty-four hours or so; but when the foliage was very fine, as in the case of some *Acacias* that are rather subject to the scale, we have found dipping the plants overhead in a thin clay paint as good as anything we ever tried, syringing when the plants were too large to be dipped. The efficacy depended on every part of the plant being covered, and then laying it carefully down in a dry shady place. In from twenty-four to thirty hours the smearing would be dry enough to shake off or rub off between the hands, and in general the scale would go with it, and some good syringings would make the leaves all clean. By such means the bug and scale may be got rid of if confined to the tops of plants, but it will be more difficult to clean them when the insects go down to the roots. In such a case, as they will be sure to rise at their leisure, the whole of the earth would require to be washed away, and the roots well washed before the plants were repotted. As a sort of test or trap, if you wish to know if a thrips is in a house, put a few *Kidney Bean* plants in it—the thrips will be sure to find out the plants; and again, a healthy *Coleus* plant in a stove or warm greenhouse will soon tell you if you have a mealy bug at hand, for of that plant they are very fond.

Planting and Transplanting.—These matters will most likely occupy a considerable portion of our time. The last two seasons have been unfavourable for all planting on a large scale, whether for ornament, for profit, for cover, or for all combined. The ground was so dry twelve months ago that planting in the autumn was in many places quite impossible, and spring planting was followed by the driest summer, on the whole, we ever experienced. Now, the rains, though they have not gone down much, will render planting more practicable. Taking circumstances as they are, a few hints may be useful, and the old rule still holds good for all exposed places, "plant thickly and thin quickly." The first part of the rule is based on the fact that purchased plants generally stand thickly in the nursery, and setting them out thinly exposes them to a greater danger of having their vital juices sucked out of them by the keen frosty winds of spring. Whilst they stood close together in the nursery rows, the one protected the other. On this account where much planting is to be done in exposed places, the time and labour would be anything but lost, if the young trees were set out thinly in nursery rows for a year or two on the estate before being moved to the plantation. The thinning quickly is just as important where a healthy plantation is desirable, and the thinning should commence as soon as the branches of the young trees approach each other. If the thinnings at first are not large enough to be useful, the trees might be pruned-up considerably for a year or two before cutting out, so that the others might have room. For anything in the way of cover the permanent trees should feather to the ground. When trees are left thickly, all the lower branches must die from want of air. Frequently a whole plantation becomes unhealthy and covered with insects from mere exhaustion from want of thinning. The soil that would have supported one hundred trees in luxuriance, will hardly keep three or four hundred alive. The same rule holds true as to ornamental plants. To make them grow quickly they must be nursed, but the nurses must be removed as the principal plants need the room. To

have the plants on the estate is in all cases a great advantage—the roots may be muddled as taken up, and not too many taken up at a time. Many forest trees and ornamental shrubs are greatly injured when brought from great distances, for they are so dried and heated in the journey. For raising trees and shrubs, on the mere principle of the division of labour, the nurseryman will ever beat the gentleman and his gardener, or even forester; but a great gain would often be obtained by having the plants on the place a year or two before final transplanting. The extra time, room, and labour will be anything but lost—quite the reverse.

One more hint for the present. Much would be gained if it were well understood that cheap plants and cheap planting are anything but synonymous with profitable planting. Owing to the rage for mere cheapness and the severe competition, nurserymen strive to meet it, and advertise plants of certain heights at very low prices. They can only sell at these prices by having the plants standing thickly, almost touching each other's stems in the row, and thus occupying but little ground. Such protected plants turned out on an exposed hillside, say 4 or 5 feet apart, can hardly stand the severe exposure; the bark, &c., being so tender and fine. Hence the reason, as above stated, for wider planting and home nursing for a year or two. The nurseryman cannot give you the advantage of transplanting and re-transplanting without a corresponding charge, but that extra charge would in most cases be anything but an extra expense. We are sure that the present system of drawing plants up thickly and selling cheaply will be, as a rule, to the advantage ultimately of neither seller nor buyer. In advertisements we should like to see a fresh feature—not merely the height and price of the plants, but the times transplanted and the distance they stand from each other. The distance must be paid for, but those who buy and plant at once would find out that in the end it was cheapest to buy proper plants. A few years ago we planted some beautiful Larch 30 inches in height, with robust stems feathered to the ground, nice little pyramids, and we believe not one failed. They stood in rows 3 feet apart and 2 feet from each other in the rows. We paid a little more for them than for trees of a similar height that stood thickly in the nursery rows; but for security against failures, thinner planting at first, and rapid growth afterwards, they were well worth three times the money given for the others. There would be fewer yearly makings-up of plantations and shrubberies if, either at home or at the nursery, there were more preparation and room given to the plants before final transplanting. Let those interested look to it; they will then see it is no loss to pay the grower for transplanting and additional room.—R. F.

TRADE CATALOGUE RECEIVED.

Ellwanger & Barry, Mount Hope Nurseries, Rochester, New York. *Descriptive Catalogue of Fruits. Descriptive Catalogue of Ornamental Trees, Shrubs, Roses, &c.*

TO CORRESPONDENTS.

* * * We request that no one will write privately to any of the correspondents of the "Journal of Horticulture, Cottage Gardener, and Country Gentleman." By doing so they are subjected to unjustifiable trouble and expense. All communications should therefore be addressed *solely* to *The Editors of the Journal of Horticulture, &c.*, 171, Fleet Street, London, E.C.

We also request that correspondents will not mix up on the same sheet questions relating to Gardening and those on Poultry and Bee subjects, if they expect to get them answered promptly and conveniently, but write them on separate communications. Also never to send more than two or three questions at once.

N.B.—Many questions must remain unanswered until next week.

Too MANY QUERIES (*An Old Subscriber*).—There is no book containing pictures of every known plant. Heat your small greenhouse by a gas stove. We name Ferns from specimens. You could safely sow the seeds as you mention. Other queries in "Our Letter Box."

PEBBLES ON SHELVES at Kew (*A Constant Reader*).—The pots rest on fragments of Derbyshire spar spread on the shelves.

PEACH TREES (*J. A. Dublin*).—Peach trees without glands are more subject to mildew than those with them. Have Rivers's Early York and Dr. Hogg in your greenhouse.

LATE PEARS FOR SOUTH-EAST WALL (*G. G.*).—Bergamotte Espereu, Beurre de Rance, Colmar, Glou Morcean, and Ne Plus Meuris.

PEARS FOR WEST WALL (*B. S.*).—To ripen from October to January inclusive, we advise for quality and productiveness, Marie Louise,

Beurré Diel, Hacon's Incomparable, and Glou Morcean. Gansel's Bergamotte and Brown Beurré are also excellent. You do not say where you live, therefore we can form no idea as to whether Stimpson's Apricot would succeed or not on a west wall, but unless you are south of London it would not. A Green Gage Plum would do very well, and so would Kirke's, Victoria, Jefferson, and Coe's Golden Drop Plums.

FRUIT TREES FOR EAST AND WEST WALLS (*A Cottage Gardener*).—On your 57 yards of wall with an east and west aspect, you will have room for six trees on each side. The west devote to Pears—viz., Flemish Beauty, Marie Louise, Beurre Diel, Passe Colmar, Van Mons Léon le Clerc, Glou Morcean; and between these we should have vertical double cordons, and also at the ends, or seven trees—viz., Beurré d'Amanlis, Louise Bonne of Jersey, Beurré Giffard, Beurre Superfin, Josephine de Malines, Ne Plus Meuris, and Bergamotte Espereu. The east wall will suit Plums and Cherries. We should have at least one Cherry; Empress Eugénie, an early form of May Duke, being excellent. Plums: Green Gage, Jefferson, Kirke's, Victoria, and Coe's Golden Drop. Between these you can have double vertical cordon Apples—viz., Kerry Pippin, Callini, Adams' Pearmain, Cockle Pippin, Golden Pippin, Sykehouse Russet, and Cox's Orange Pippin. For the north wall nothing does so well as the Morello Cherry. One would be enough. There is no chance of a Black Hamburgh or Royal Muscadine Vine succeeding on either an east or west wall.

KEEPING WALNUTS (*G.*).—You will see what we said last week. If stored in the green shell this decays and imparts a bad flavour to the kernel.

WHITE GRAPES (*Southamptonensis*).—We cannot name a Grape from one or two berries. It may be Syrian, White Tokay, White Lisbon, or even White Muscat. From a portion of a bunch with leaves we might be certain of the name.

VINERY AND CONSERVATORY (*R. I.*).—We think you are distressing yourself unnecessarily about the heating of your houses. We have no doubt the boiler you have will heat the three houses. Of course there is a greater risk in heating three houses than in heating one by a boiler, as in the one house, if the boiler gave way, one house only would be in danger. To make yourself thoroughly secure it would be best to have two boilers, both connected with the main flow and return, and both shut off by valves if desirable. If anything happened with one boiler you could disconnect it and work the other. The boiler you have, however, may do its work well for many years without a flaw. As far as we know, the mode of heating is good. The boiler is placed, say, near the west end of the vinery, and pipes go across the back or north end of the conservatory until they reach the next vinery. The pipes from the boiler across the end of the conservatory act as flow and return, and from thence, we presume, by valves or otherwise, the other houses can be heated separately or all together. The four pipes round the vineries will be ample; but as we presume the conservatory is a span 20 feet wide, two pipes at each side, and at the south end, minus the doorway, would do to keep out frost; but to maintain a stove or tropical heat in winter, you would need nearly double the piping if the house is at all lofty. The arrangement of the conservatory must be a matter of taste. If rather low, have a border for plants and climbers all round, a walk all round, and a bed in the middle; if lofty enough, then borders, but a narrow stage all round, and a stage of flat sparred table, or a stone or slate platform, in the centre. The 32-oz. glass will be warmer in winter than thin glass. Roses in pots for house culture should be managed according as you force them much or not. The less they are forced—that is, brought on very gradually, the better will the blooms be. The pots should be well filled with roots before being set in the house. If out of doors now, protect the pots from frost.

DESERT AND PRESERVING GOOSEBERRIES (*J. C.*).—For desert—Early Green Hairy, Pitmaston Green Gage, Red Champagne, Yellow Champagne, Warrington, and Whitesmith. These have all small highly-flavoured berries. If you wish for larger, then of the large or Lancashire prize sorts—Red London, Dan's Mistake, and Conquering Hero. Yellow: Catherine, Leveiler, and Drill. Green: Thumper, Stockwell, and Telegraph. White: Antagonist, Freedom, and Hero of the Nile. For general purposes Crown Rob, Ironmonger, Keen's Seedling, Roaring Lion, and Warrington, with Runkhullion for bottling.

AMORPHOBALLUS HULBIFERUS TREATMENT (*Idem*).—It is hard, succeeding in a sheltered border well drained, and does well in sandy soil with a portion of sandy peat. The ground about the plant should be mulched with partially decayed leaves that may remain on until spring, and then be pointed-in. It is also known as *Arum hulbiferum*. The broad-leaved plant is *Escallonia rubra*, and the narrow-leaved *Daphne Cneorum*.

SALTING ASPARAGUS BEDS (*Idem*).—We do not recommend the salt to be applied at the time that the haulm is cut off and the beds manured for the winter; but in spring, when you dress the beds, give a dressing of salt, and another in May.

LATE PEAS (*Colonel G.*).—The best late Peas we have partaken of this autumn were from the garden of B. Drew, Esq., Streatham. They were British Queen, and the gardener, Mr. Baldwin, said that they were sown very deep on the 29th of May, were watered about a week after twice, but no mulching was put over the roots. They will continue bearing until the end of this month.

PRUNING PEACH TREES (*W.*).—You may cut out the old wood now, and during the next month you may perform whatever pruning is required; but as you practise summer-pruning, but little will be needed by the present year's wood and that for next year's fruiting.

GATHERING MEDLARS (*C. N. B.*).—Now is a good time to gather them. The proper time is when they come away freely from the tree, which is usually when the leaves have begun to fall. They should be gathered on a fine day.

RHUBARB GROWN FOR MARKET (*H. K.*).—We believe the market gardeners near London make fresh plantations annually—taking up the old roots for forcing. This is what Mr. Cuthill says in his little book on "Market Gardening." "Rhubarb-growing out of doors is so simple that little can be said respecting it. The ground being heavily manured, a plant is taken up and divided into as many eyes or buds as it possesses. These are planted 4 feet apart, and by the autumn they will have produced roots from 6 lbs. to 10 lbs. in weight. The oldest roots are generally taken up for forcing; and by always having a good rotation, the grower has the power of continually cleaning the ground, and thus obtaining a heavier crop. The forced plants will furnish eyes for a continual succes-

sion, without growing plants for the purpose, and the eyes may be divided and planted again for a main crop."

CAULIFLOWERS MAGGOTED (N. C. H.).—We cannot account for Cauliflowers sown in April not having headed before, but we think you have mistaken Cauliflower for Broccoli, which will not head before next spring. Both are subject to the ambury or club, which has been unusually prevalent this season. We know of no remedy; but it is said that charcoal dust spread on the ground about half an inch thick acts as a preventive, and a dressing of gas lime, twelve bushels to the acre, has been found to ward it off. It is also said that fresh soot, one gallon to a pound of sulphate, brought to the consistence of thick paint, will keep the maggots from plants, of which the roots and stems are dipped before planting. All you could do now would be to water the plants with ammoniacal liquor from the gasworks, diluted with six times its bulk of water.

POTATOES (H. S.).—Apply through some friend to the dealers in the Borough Market, or else advertise them, saying the price you require, &c.

SHRUBS FOR LOW SOUTH WALL (E. E.).—*Chimonanthus fragrans*, *Cydonia japonica*, *Indigofera floribunda*, and *Cotoneaster Simmoudsii*, it being only partly evergreen, the others being deciduous. Of evergreens, *Ceanothus aznreus*, *C. dentatus*, *Garrya elliptica*, and *Ligustrum japonicum*. For the north wall, *Calycanthus macrophyllus*, *Crataegus Pyracantha*, *Cotoneaster microphylla*, and *Ivy*.

TREATMENT OF A HOLLOW ASH (S. Adams).—There are many associations about old hollow trees that make people anxious to preserve them, though afraid the first tempest will bring them down. We have seen old hollow trees preserved and thriving afterwards by filling the hollow with flints, bricks, &c., and running the mass firm with thickish concrete. We have known some cases in which the trees seemed to take a new lease of existence, making fresh wood and adding layers of fresh bark every year. We are a little doubtful if it would be worth while doing this in your case, as you speak of encasing the outside with bark. If there is no bark there can be little or no life. We have known cases, however, in which hollow trees, treated as above, and with spaces all round where the bark seemed gone, have become covered with fresh bark on all such places being coated with cow dung and clay kept on with cloth to exclude air. This could only be done when the head of the tree was fresh.

SELECT FUCHSIAS (H. F. T.).—*Agnes*, *Avalanche*, *Empress*, *Heather Bell*, *Enchantress*, and *Innocence*; the preceding are light. Dark sorts—*Haven*, *Blue Boy*, *Duadem*, *Lord Elcho*, *Emoch Arden*, and *General Grant*.

SELECT ROSES (Idem).—*Hybrid Perpetuas*: *Alfred de Rougemont*, *Caroline de Sausal*, *Charles Lefebvre*, *Gloire de Saintenay*, *Jules Margottin*, *Leopold I*, *Madame Victor Verdier*, *Maréchal Vaillant*, *Pierre Netting*, *Prince Leon*, *Senator Vaisse*, and *William Griffiths*.

TROPEOLUM TUBEROSUM (Rash).—If it is planted out against a south wall the plant will need no protection in winter, except mulching over the roots and covering with partially-decayed leaves or dry short litter to the depth of 3 inches, removing the mulching in March. It would be advantageous to shelter the shoots with mats or canvas in spring, in case of severe frost after growth has commenced. The plant is only half hardy, and does not usually flower well out of doors except in warm soils and situations. *T. azureum* and *T. tricolorum* will, no doubt, start again. They will need to be kept in the greenhouse in a light position.

WINTERING GOLDEN FEATHER PYRETHRUM (Berkhampstead Subscriber).—It is not necessary to place the plants in a greenhouse, though it is often done. They winter quite safely in the open ground, being perfectly hardy in all well-drained soils. This Pyrethrum stands the winter best in light dry soil in a warm situation. It is not necessary to raise seedlings every year, for it is readily increased by slips or cuttings put in either in spring or autumn in a gentle hotbed, though they do well in a cold frame in August. Seedlings, however, are the most free-growing. The seed should be sown in July, and the plants pricked out when large enough in light soil in a sheltered position. They should be put out about 3 inches apart. In spring they may be planted where they are to remain.

SOWING GORSE OR FERZE SEED (Idem).—It is best propagated from seed, which should be sown in March. It prefers light dry silt. We admire the common Gorse as much as anyone, but think it out of place in a garden, being inferior to the double-flowering, which we have in large clumps, and no yellow-flowering shrub can surpass it when in full bloom. Plants in pots may be had at most nurseries at a cheap rate. We have it in groups by the hundred.

PROTECTING PASSION-FLOWER (An Old Subscriber).—It is necessary for us to have some data in order to form an opinion. You do not say what the kinds are, nor in what position they are grown, but we presume they are the hardiest sorts, which in the midland counties require a south wall, and a protection of mats or straw in severe weather, to be removed when it is mild.

THRIPS ON LAPAGERIA ROSEA (X. of Sidmouth).—The leaf sent us is infested with thrips. Your remedy is to shut up the house on a calm evening, and fill it with tobacco smoke so densely that a plant cannot be seen from the outside. You should repeat the fumigation next night but one, and two days afterwards give a thorough syringing. Your plant must have been seriously neglected as regards water, otherwise it would not have been in such a bad state, and the atmosphere has been much too dry.

GESNERA ZEBRINA FLOWERS FALLING (W. N.).—We think the flowers do not expand from the circumstance that they have hitherto been grown in a higher temperature, and you have given them a lower for flowering; consequently, the plants have received a check. Water moderately and afford abundance of light. We think they will do better when they become used to the temperature. Perhaps you have given them an overdose of liquid manure.

RETARDING CHRYSANTHEMUMS FLOWERING (Idem).—The only way that we know is to place them in a north aspect, but with plenty of light, and though that will retard them, you risk losing the flowers from frost, therefore you will need to have protection in readiness to save them from severe frost. We would house them and keep them cool by giving an abundance of air.

COAL ASHES AS A TOP-DRESSING (D. G.).—They would not be of any benefit as a top-dressing to light soils, nor would they increase fertility.

REMOVING HOT-WATER PIPES (Idem).—There is no mode of removing the "borings" that are used in making the joints, except by clipping

out with a chisel, a tedious and difficult operation, and not infrequently the joints or sockets are broken. It is best, we think, to cut the pipes with a file, and in such a place that they can be joined with a pipe having sockets at each end. Perhaps you will need to operate where the elbows are, then it would be best to break them, and you can free the sockets of the broken portion and add the additional length you require.

LASIANDBRA MACRANTHRA, BOUGAINVILLEA LATERRITIA, AND SOBRIALIA MACRANTHA (T. C.).—*Lasiandra macrantha* is the same as *Pleroma macrantha*. The *Bougainvillea* should have a temperature of from 55° to 60° at night, and from 60° to 65° by day from the present time to March, and in March you should start it if you wish for flowers in May. Give it plenty of moisture as well as heat; keep it dry during the winter, and prune it before starting, or in February. You will need to afford it a light position. It would be more likely to flower if pruned but little, and not overtopped. The old stems of the *Sobralia* ought not to be cut away, but should be allowed to die off naturally. They will not flower again, but from them you will have the parts for future flowering.

PERENNIALS FOR A BORDER (R. L. D.).—*Agrostemma coronaria*, *Ajuga alpina*, *Alyssum saxatile*, *Anemone apennina*, *A. coronaria* vars., *Anemone theca cruenta*, *Antirrhinum*, *Aquilegia Skinneri*, *Arabis alba*, *Anbretia deltoidea grandiflora*, *Aster alpinus*, *Campanula aggregata*, *C. pulla*, *Cheiranthus Marshallii*, *C. alpinus*, *Cyclamen coum*, *C. hederifolium*, and *C. hederifolium* album, *Delphinium alpestris*, *D. belladonna*, *Dianthus barbatus*, *Dianthus spectabilis*, *Draba aizoides*, *Erigeron grandiflorus*, *E. speciosus*, *Gentiana acaulis*, *Geranium sanguineum* and *lanceolatum*, *Gum coccineum grandiflorum*, *Helleborus niger*, *Hepatica triloba*, *H. angulosa*, *Helycathus anethystinus*, *Hypericum calycinum*, *Iberis saxatilis*, *Iris reticulata*, *I. attica*, *I. pallida*, *Lilium tenuifolium*, *Linum alpinum*, *Lycium alpinum*, *L. haageana*, *L. viscaria splendens*, *Lythrum roseum superbum*, *Meconopsis cambrica*, *Mysotis aizocica*, *M. sylvatica*, *Eriochloa macrocarpa*, *Orobanchis venosa*, *Oxalis tropaeolides*, *Prionias*, *Papaver alpinum*, *P. nudicaule*, *Puls Nelsoni*, *P. verna*, *Polemonium coruleum variegatum*, *Primula acaulis*, *Auricularis*, *Pyrethrum*, *Salvia nemorosa*, *Saxifraga aizoides*, *S. Andrewsii*, *S. juniperina*, *S. oppositifolia*, *S. cuneata*, *Sempervivum californicum*, *Silene Schaffii*, *Sisyrinchium grandiflorum*, *Spiraea Filipendula flore-pleno*, *Statice Gmelini*, *S. latifolia*, *S. minuta*, *S. tatarica*, *Symphyltum caucasicum*, *Thalictrum aquilegifolium*, *Trollius europaeus*, *Tussilago Farfara variegata*, *Veronica candida*, *V. Tenerum*, *V. alpestris*, and *V. hybrida*.

OLEANDER SCALE—GERANIUM LEAF BLACKENED (M. H.).—The Oleander leaf is attacked by scale, the Geranium leaf by the insect's secretion turned to a black fungus. Fumigation with tobacco will not kill the scale, nor will it be of any benefit to either. Pick off the scale from the Oleander with the point of a knife, and syringe the plant with a solution of soft soap, 3 ozs. to the gallon of water, and add ten drops of spirits of turpentine. The solution should be applied at a temperature of 140°, laying the plant on its side and turning it round, so as to thoroughly wet every part. Keep the solution from the soil. The Geranium will not need any application.

CHRYSANTHEMUM SENSATION FOR SPRING DECORATION (D. D.).—It is of no great value for the flower garden in spring. Your best plan would be to let the tops remain and mulch with partially-decayed leaves, cutting off the tops in March, and if the spring be warm the shoots may come up strong and have a good effect, but it is far more likely that they will be damaged by frost. For summer decoration take off the suckers in November, put them singly and place them in a frame, protecting them from frost in cold weather. It will answer just as well to save a few of the old plants, take cuttings from them in March, and place them in a gentle hotbed. When rooted pot them off and place them in a cold frame. They will form plants by May. Stop them to make them bushy.

PLANT FOR WALL OF ORCHID HOUSE (E. C. W.).—There are few plants that combine handsome flowers with variegated or fine foliage. *Passiflora trifasciata* may suit, as it has variegated foliage and ornamental flowers; but we should prefer *Cissus discolor*. The finest flowering covering of a wall that we have seen consisted of *Euphorbia jacquiniiflora* and *Passiflora quadrangularis*.

APHIS ON TYLIDIAS AND GESNERIAS (Croydonian).—The leaves sent have every appearance of having been attacked with the white aphid, which is most difficult to extirpate. Fumigation with tobacco is the only remedy we know, previously sprinkling with water the floor and every available surface, but not wetting the foliage.

CENTAUREA PROPAGATION (Idem).—The best way is to take off the side shoots close to the stem, pare the base smooth, and insert them in sand, placing them in a house with a temperature of from 60° to 65°. They may be inserted in summer in a frame, or in spring in a gentle hotbed. Perhaps spring is the best time. Be careful not to overwater, nor to keep too moist an atmosphere, otherwise the cuttings will damp. Keane's "In-door Gardening" will suit you. It may be had, post free, from our office for twenty postage stamps.

DRAINING A GARDEN (W. K.).—The cheapest and best method of draining is with tiles. The drains should be 4 feet deep if you can command sufficient outfall, and they ought not to be further apart than 21 feet, but much depends on the soil. If strong and clayey they may be closer than where the subsoil is gravelly or sandy. The prices of tiles and digging drains vary so much in different parts, that we can give you no fair idea of the cost. Consult some farmer or person accustomed to draining in your locality.

FUMIGATORS (A. D.).—Both these which you mention answer fully the desired purpose. Any dealer in such articles could supply you. No subsequent supplement has been published.

HEATING A GREENHOUSE (F. M.).—We think you will have heat enough in the house by the plan proposed. We presume that having the pipes near the back wall and so far from the ground level, is to suit the independent conical boiler that is to stand shut off by a glass partition in one end of the house; but for that the pipes would have had power if placed near the ground beneath the first floor stand. Most likely you could not manage that without somewhat sinking your boiler, as you cannot well take hot water below the boiler. Your shelf at the back seems also very high—6 feet from the ground. Why not have it a little above the stage in front? The pipes, if desirable, might come farther from the wall than 9 inches, but even at that the Vines stems would not be apt to suffer much. Vines would do well at the back if the soil were suitable and drainage. Without Vines, Camellias and Oranges, with an Acacia or two,

would do admirably against the back wall. The pipes would throw off more heat if placed on the same level instead of above each other.

AMERICAN BLIGHT *E. G., Leighton Buzzard*.—Slake some lime and add some salt, and apply with a brush. Some people add a little cow dung.—**W. F. RADCLIFFE.**

NAMES OF PLANTS (*Rev. S. L. Wilson, Prestbury Vicarage*).—*Lycium barbarum*, very commonly known as the "Tea shrub" in cottage gardens. (*H.*)—1 and 4 are the Lady Fern, *Athyrium Filix-femina*; 5, *Lastrea Filix-mas*; 3 and 6 are *L. dilatata*; 2, *L. spiculosa*, a variety of *dilatata*. (*M. R.*)—1, *Pteris flosma*; 2, a small var. of *Scolopendrium vulgare*; 3, a *Lastrea* not recognised by us; 4, *Campyloneuron lapathifolium*; 5, possibly *Cystopteris alpina*. (*G. P.*)—We do not identify your Fern, as it is not in fruit. Cannot you forward us part of a frond bearing sori? (*E. T.*)—*Campanula Pertenschlagiana*. (*M. H.*)—1, *Aster lavis*; 2, *A. Novi-Belgii*. (*H. J., Foto Island*)—1, *Clematis graveolens*; 2, *Aster Novae-Angliae*; 3, *Aster grandiflorus*; 4, *Artemisia*, apparently *Abrotanum*. (*T. B. W.*)—1, *Pteris longifolia*; 2, *Platyloma (Peltis) adiantifolia*; 3, *Adiantum nephrolepis*; 4, *Pteris serrulata*; 5, *Polypodium vulgare caribricum*; 6, *Nephrolepis cordifolia (N. tuberosa)*; 7, *Athyrium umbrosum*; 8, *Davallia Nova-Zelandiae*; 9, *Polypodium aureum*. (*M. D.*)—*Encomis punctata*, a Cape bulb. (*Marlow Cottage*).—The popular name, "Bottle Brush," is applied to the whole genus of the Horsesails, *Equisetum* of botanists.

POULTRY, BEE, AND PIGEON CHRONICLE.

POULTRY SHOW REPORTS.

I SEE that your correspondent, "SHROPSHIRE RECTOR," in the number for October 13th, gives me a gentle "dig," not a blow, still less an ill-tempered scratch, rather let me call it a sort of a pat, and then, fearing he has knocked off the skin, he puts on a plaster. Thus he says, "I am sure the value of 'our Journal' in a poultry-fancier's eyes would be greatly increased if we could have more detailed accounts of the poultry exhibited." Then comes the gentle dig or pat, "I do not mean such an account as that of 'WILTSHIRE RECTOR'S' journey to Stroud, in which the journey occupies about ninety lines, the fowls thirty, and the Pigeons eight." Then follows the plaster—"No offence to our good friend, whose letters are always amusing, and whose acquaintance I hope some day to make." These remarks afford me an opportunity of saying what I have been wishing for some time to say. As to my brother of Shropshire, I the more easily recover his pat, inasmuch as my opinion some years ago was not wholly unlike his. But now, after eight years' experience as a writer in this Journal, my opinion is, that reports to be readable, and especially to vary one from another, must deal more with the surroundings than with the birds themselves; and for this reason, that the birds exhibited are not only very much alike, but in many cases they are the very same birds. Thus, as one comes to a pen one says, "Ah! here are So-and-so's old Rose-combed Dorkings;" or, "Well, the Bristol Spanish are looking wonderfully well after so many journeys;" and so in a great measure it is throughout, except with the awkward squad—the birds sent by persons living near, and who do not understand poultry, and which birds are utterly unworthy of a remark. But if this be true of the fowls, it is even more true of the winning first-class Pigeons. A few fanciers have the best birds in the country, and win all or nearly all the prizes, and these birds are almost as well known at a show as their owners' names are known in the prize list.

But, again, "SHROPSHIRE RECTOR" remarks upon the reports of the judges (and by way, who so fit to report as those who have studied every pen in order to decide the prizes?), yet I can tell him that the best judge in the world gives usually in his reports but very few details, and he as well as I know the reason why.

Further, poultry in itself is not a very wide subject, and if one wrote diffusely every time of the Dorking's fifth claw and its position, or of twisted combs, or of removal of hairs from the face, or of a duck foot, we should make each volume of this Journal as alike as the covers, the dates only differing. Or as it was said by the poet of a Dutch garden, where—

"Each alley has its brother,
And half the garden just reflects the other."

But there is a further reason still. There is an authoritative "Standard of Excellence," at least one now received with great respect by all poultry fanciers. Let "SHROPSHIRE RECTOR" master that, and he will gain great knowledge of detail. But I do not see that we should print it part by part; to do so would be as great an error, to my mind, as to make the gardening department of the periodical an enlarged repetition of old Abercrombie brought down to the present time. I venture to think that the complaint of "SHROPSHIRE RECTOR" is that of a beginner.

I can further illustrate my meaning in this way. Where, until Mr. Blakston wrote, were Canaries? We had indeed occasionally an answer to an inquirer about long claws, or wheezing, or moulting; but how different now, when, during the last few years, we have had lengthy and excellent articles on Canaries. The reason is, I believe, because "W. A. B.'s" witty and readable papers have pushed forward the fancy. I consider that Mr. Blakston's account of the Crystal Palace Show of last February was one of the very best reports, if not the best, I ever read, and yet he always deals as much at least, or even more, with the surroundings than with the birds themselves. If a report were extended to many papers (one I think was even to six), and were it full of minutiae, I should break down in the reading, and read scarcely half.

"SHROPSHIRE RECTOR" mentions the Stroud report particularly. Now, I know the burden of care on the shoulders of committeemen, and never make complaints, especially if it be a first show. But as Stroud is specially mentioned, I must remark that after having paid 5s. entrance I never got a prize list at all. It was not printed by the time I left—viz., five o'clock, and one was sent to me by post afterwards. Such a state of things must cripple a reporter sadly. It is even a fact that all the prize cards were not on the pens when I left, and I should not have known which birds got the prizes in the Game classes but for the courtesy of the Rev. Mr. Hodson the Judge. Sad state of things indeed, but true nevertheless!

"SHROPSHIRE RECTOR" implies, unless I mistake him, that I write only to amuse; he will permit me to remark that I have a far higher aim, which is, by writing readable articles (readable by those who are not fanciers) to raise and enlarge the fancy, to extend it to those who have not as yet learned to love those beautiful birds which we love. But we must gain ears before we gain hearts, and I am sure an Eaton or a Brent, excellent in details though both were, never increased the Pigeon fancy, while I have seen on many a bookcase "The Dovecote," because its author knew how to write interestingly. Of poultry simply and solely, and its details, it would be impossible to write year after year, and many years in succession—the subject is not wide enough. Thus it is not unfrequently the case that ardent young poultry fanciers say to me, "What a pity there is no periodical for poultry only." I tell them it was tried years ago, and failed, and would fail again; the subject is too narrow. "Our Journal," taking in so many pursuits, fancies, and hobbies, succeeds, and for that reason. I have, during the many years I have written, come to know from the many private letters what class of papers readers are good enough to be pleased with, and without the least wish to be egotistical I must beg leave to add in conclusion this anecdote. A Pigeon paper of mine, "A Day at Devizes, and What I Saw There," written in the spring of 1865, happened to be copied into the county paper. I met for the first time soon afterwards a Wiltshire gentleman, who asked me "if it were true that I was the writer of it." I did not deny the soft impeachment. He replied, "Why you write so as to make people run off and buy fowls and Pigeons." I said, "That is just what I wish." I repeat, that I state this from no egotistical feeling, but to show that, although I am not "a dry detail dealer," yet I have, I trust, done some little good to the poultry world.—**WILTSHIRE RECTOR.**

As "SHROPSHIRE RECTOR" remarks, a report should contain something definite—something by which an absent exhibitor or breeder may properly estimate the relative value of his own and other birds. I have known cases where winning birds have been claimed by post or purchased afterwards from great distances, simply because they were winning birds, and upon arrival they were found to be indifferent specimens after all, thus annoying and disappointing the purchaser, and creating a feeling of distrust against the seller. I sincerely hope, therefore, that next week we shall not read of the winning pens of Light Brahmas at Southampton as being "a better lot than those of previous years," or "as a whole not so good as last year." Let us have some idea of the size, perfection in marking, and other excellencies, relatively, of the leading birds.

Mr. Wright's suggestion respecting commendations is well worthy of adoption. I fully endorse his remarks upon the entry fees at Birmingham. Let us hope that another year the Committee will consider the advisability of a change, abolishing the present subscription for a high entry fee. I can answer for many first-class pens in the west which, but for the high fees, would be sent singly, as both credit and the expense of carriage would prevent middling pens being entered.

Southampton Show will, doubtless, be a great success; but it really is too bad of Hampshire fanciers and the Committee to allow such breeds as Cochins, Chinas and Hamburgs to remain so far in the background. The proper number of classes, say three for Cochins and four for Hamburgs, would bring great improvement, and, I feel sure, cause no extra expense. How can the Committee expect to see any display of my favourite, the White Cochins, or, indeed, of either variety?

Speaking of White Cochins, it reminds me of another cruel schedule—the Crystal Palace. I had hoped that in this list we should at least see the prizes for all Cochins as tempting as at Bristol; yet, although Buffs and Partridge are very fairly handled, the poor Whites are left with a solitary class. The reason may be adduced that the variety never show in force; but, if such is the case, the cause is obvious—they are never offered the temptations so continually dangled before the eyes of other varieties. If a cup is offered by way of variety, it is always by subscription. White Cochins are becoming more generally cultivated, and breeders will not long rest contented with their miserable classification.

Some few weeks ago I appeared in your columns for cups for Cochins and Brahmats at the West of England Show to be held at Plymouth, but in consequence of the opposition by local exhibitors to their being "open," it is now determined to restrict them to Devon and Cornwall, especially as the particular breeds (Hamburgs having been added) require encouragement in the two counties. I may, therefore, openly thank those ladies and gentlemen who so kindly offered their assistance, although I intend to do the same by letter. The fact that Mr. Hewitt will judge gives great satisfaction, especially as last year two or three flagrant cases of "undiscovered" dyeing were observed.—JAMES LONG.

[We have now inserted all the worthy communications which we have received on this subject, and, bowing to the wishes of our correspondents, we have requested, and do request, all those who favour us with comments on poultry exhibitions to include in those comments notes on the especial superior points of the birds in the prize pens. Yielding thus far to our correspondents, we must also ask them not to expect all the information that they desire; we must ask them to consider who made the awards. If he is a man of known ability and integrity they may accept as certain that the birds to which he awarded prizes are good. We must also ask our correspondents to consider that adverse criticisms upon awards are painful to the judge, galling to the prizetakers, and irritating to those next below them. Bearing all this in mind, we will do our utmost to satisfy the wishes of our readers.—EDS.]

THE LONDON POULTRY AND PIGEON SHOW.

LAST week we briefly noticed the schedule of the above exhibition, but reserved a fuller review for our present issue. We are very glad to find the Committee offering such a valuable and at the same time so comprehensive a prize list. They are evidently endeavouring to make this show at the Crystal Palace one of the first, if not the first, of its kind in the kingdom, and with the vast resources and conveniences to be found at the Palace, we see no reason why they should not succeed if only exhibitors and the public give them the support they deserve.

The Committee have acted wisely in holding the Show simultaneously with the Cattle Show, for those interested in the one will mostly be interested in the other. All the prize birds are to be sold by auction on the Wednesday (Dec. 7th), and should any bird realise more than the catalogue price the excess is to be equally divided. This is a move in the right direction, as all will then have a fair chance of purchasing any prize bird they may choose. Most of the poultry have separate classes for old and young, the old birds to be shown cock and hen, and the young as single cockerels and pairs of pullets. For each class there are three prizes of £3, £1 10s., and 10s., and a silver cup or piece of plate, value five guineas, for the best pen in most classes. Light Brahmats have three cups. Spanish are treated more liberally than any other variety, as they have two five-guinea cups for old birds, and two of six guineas and four prizes for young. Hamburgs are shown cock and hen together, and all compete for a cup. Game are any age, cocks and hens, but only one hen this year. Polish are divided into three classes. Malays have as many prizes, and no doubt "the real big birds" will appear. Brown Red Bantams have a cup for the best cock or pair of hens. There are three selling

classes—for a single cock, two 10s., a cock and hen—with four prizes for each class. Black Duck, Ornamental Waterfowl, and Pheasants have each a separate class.

The Pigeons are divided into no less than fifty-one classes, with seventeen cups, and we expect to find the most interesting, the greatest, and the best show of Pigeons ever seen, as we believe we are correct in saying never before was such a complete schedule issued. Pouters are divided into fourteen classes—Carriers eight, Tumblers five; each of these varieties, also Barbs, have a cup for birds bred in 1870. Jacobins and Fantails compete together for a cup. Foreign Owls and Dragoons have one for the best pair. There are several novelties, amongst which is a cup for the best collection of four pairs of Pigeons, exclusive of Carriers, Pouters, and Tumblers; the latter have one for the best four pairs, and another is offered for the best pen of six working Antwerps. Each of these classes will prove very interesting.

The total amount offered for competition is between £600 and £700, with nearly forty cups. The entries close on November 12th.

FORM VERSUS WEIGHT.

I QUITE agree with your correspondent, Mr. T. E. Kell, especially as to Turkeys, Geese, and Ducks. They won by size at the past, and it appears will do so at future Birmingham shows. I have proved by experience that such birds are of no use, at least in the following season, for breeding purposes. Facts are stubborn things. I had a Goose a few years ago fed up to the so-called Birmingham standard. She laid fifty eggs one season—a fair lot for a pudding, but not one was fertile. I can assure the Birmingham Committee I have not the inclination to destroy valuable breeding fowls to try to win laurels even at a Birmingham show. I have known in this county judges depending on the scales rather than, as it ought to be, form versus weight. Once in particular I was exhibiting my one-eyed Goliath at one of those local shows, and was annoyed at finding that the scales were to decide; and, as I afterwards told the judges, I was disgusted with any man pretending to be a judge not deciding according to his own judgment. They replied, "Just what we thought before weighing." But that is not it. I object upon principle, and interest as well, for such decisions give a premium to overfed fowls, besides making them valueless as breeding fowls.—O. A. YOUNG, *Middle Street, York.*

INQUIRY.

IN reply to the inquiry of "EAST YORKSHIRE," which appeared in your last impression, that gentleman has been made the victim of an act of unprincipled trickery. His informant turns out to be an unscrupulous person of the name of Holmes, who, seeing his opportunity, determined to effect a sale of his own "inferior stuff," even at the cost of honour and truth. In reference to my place being infected with "several kinds of disease" that is simply untrue, as the only complaint with which my fowls have been troubled has been a slight attack of the roup, which I attribute to the late wet weather, but of it they are now quite clear. And concerning the quality of my stock, I would just say that during the very week in which "EAST YORKSHIRE" visited Driffield I sent out forty birds on approval, all of which were kept, and that I have sent birds to our best breeders and fanciers for as much as £3, £4, and £5 per pen repeatedly; that I still have on hand for sale over a hundred pure-bred poultry and Pigeons of various kinds, many of them prize fowls of high quality; and that I am the only person in the town who owns a pen of first-prize Cochins. "EAST YORKSHIRE'S" informant played out his little trick very well for himself, since he succeeded in selling that gentleman a pen of second-rate birds for a first-rate price. I seriously caution "EAST YORKSHIRE" against publishing false reports respecting the state of my place and the character of my birds on the mere word of such a person.—J. PUNSON, *Driffield.*

IPSWICH POULTRY SHOW.—We have just received a schedule of prizes to be awarded at this Show. It is most liberal in its construction, offering five-guinea cups or pieces of plate, &c., for Game, Drakes, Spanish, Brahmats (Light and Dark), and Cochins; a three-guinea cup, &c., for Hamburgs, and the same for French and other varieties. A notable feature is a special prize, value £3 10s., for the best pen in the "Selling Classes," either a cock and hen or single cock. Bantams are

also well considered, having a five-guinea cup confined to their classes. For Pigeons there are nine classes, including Carriers and Barbs bred in 1870. Canaries not only have ten classes, but a special plate prize of £3 3s. for the winner of the greatest number of points. Mr. Hewitt and Mr. Willmore are secured

as censors. The Great Eastern Railway Company have liberally consented to return birds not sold free to any station from whence they received them. With these inducements, the Ipswich Show ought to have more entries than it has hitherto had.

THE BARB.

The accompanying engraving is a portrait of a Black Barb cock, four years old, and of great merit, having won many prizes at important public shows. It was specially portraited for this Journal. In giving our opinion upon this beautiful variety of Toy Pigeon, we wish to be as explicit as possible, so that our opinions may be of service to the uninitiated.

We are not assuming too much in saying the Barb requires as much care and judicious selection as does the Almond,

Carrier, and Pontor, and we call the attention of young fanciers to the following, as being the results of careful study.

The Barb attains perfection when about four years old. It should have a broad flat skull, gradually receding from the front of the head to the back; a short, thick, and strong bill, resembling that of the Bullfinch. The bill should not measure more than $1\frac{1}{2}$ inch from the point to the centre of the eye; the upper and lower mandibles to be of equal thickness or strength,

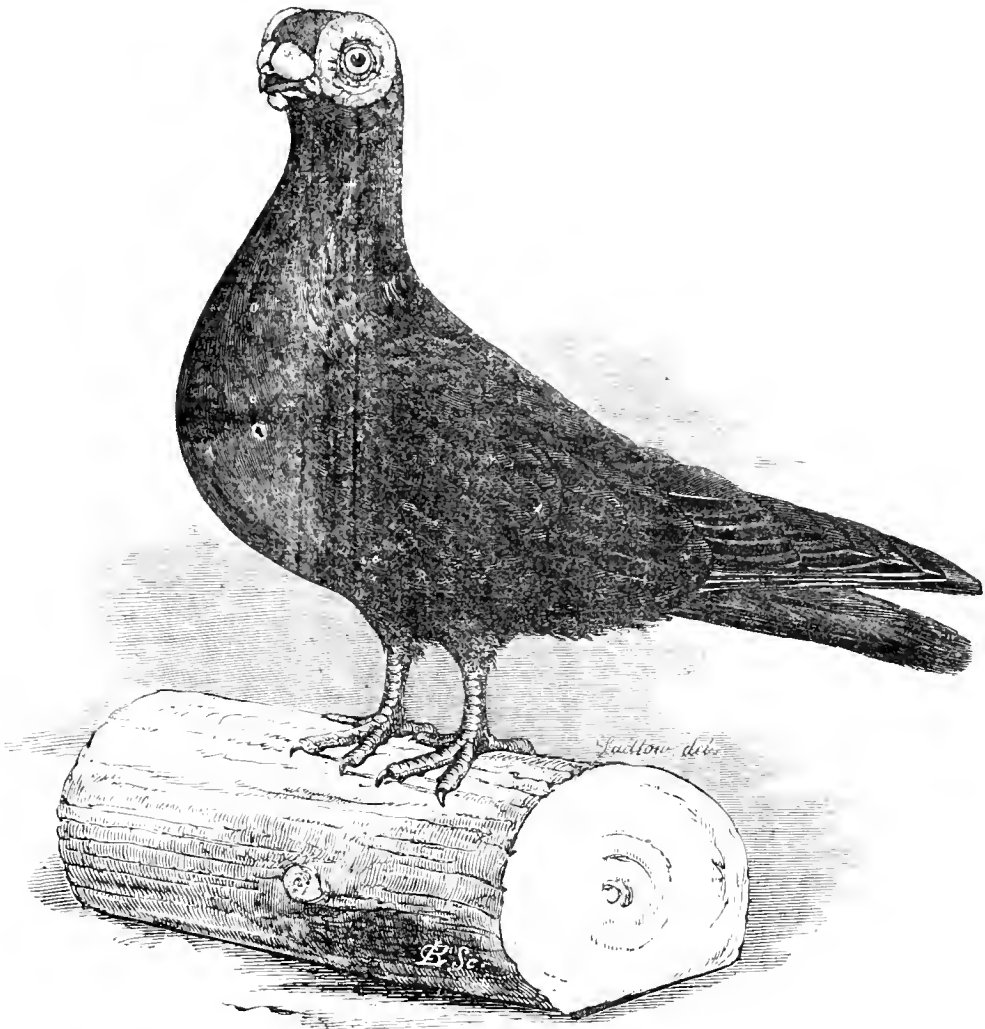

with a well-spread wattle on the upper, while that of the lower is notched from its point right into the feathers encircling the eyelash. The colour of the eye is white or pearl, which terms with fanciers are synonymous. If of any other colour it ought to be a disqualification. The cere, or wattle, of the eye is large, very thick, and of a deep red colour, circular in form, having an equal quantity at the back as at the front, or similar to what is termed a rose-eye in a Carrier.

The form of the Barb is short and strong, causing a rather heavy appearance. The neck slender, gradually thickening to a well-developed breast. The butts of the wings are prominent; their flight feathers are rather longer than those of most other

varieties of Toys. A noticeable point in the wings of this bird is, that their under or second flight feathers protrude considerably above their back from the upper or flight coverts.

There are five recognised colours in this variety—viz., Black, Yellow, Red, White, and Dun. The last-named is always dirty and disagreeable to look at, and is the result of injudicious crosses of the various colours, therefore has not that metallic lustre which so adorns a Barb in good feather, and without which they ought not to be admitted into a show pen.

Purity of colour should be regarded as indispensable. We therefore point to the desirability of breeding from birds matching in colour—viz., Black to Black, Yellow to Yellow, &c.

always having due regard to their parentage and properties. Colour has been so sacrificed by breeders for head, eye, and bill, that one never knows what colour to expect their progeny will be until they are feathered. Often Yellow and Red are bred from Black. When such is the case you will invariably find either colour is tinged on every body feather with black. Their flight feathers are either a dirty dun, or tinged with grey along the quills; their tails having several white feathers in the middle of them, or else on the top of the rump. Should one be of a passable colour you will generally find a black band at the end of the tail. By pairing Black and Yellow, or Black and Red, you will most certainly produce the same results. Red and Yellow is the only cross that any good is likely to arise from. By this cross the red is impoverished, but the yellow is obtained of a sounder colour.

If a breeder would consider for a moment he would know that Black has been the only colour that has gained by the mixture. By crossing any self-coloured bird to a Black, the latter is often improved, and the purity of the former destroyed. What is more disagreeable than to see your pet of two shades, whereas the Barb is a self-coloured bird? We might as well try to breed Mottled Barb as to have the tail and rump of a different shade to their body. However well bred such may be, they will never be fit to enter successfully into competition with birds of sound colour possessing equal merits in general.

Good Whites are very scarce, and have a dark eye—that is, the pupil almost indistinct from the iris. Several breeders have tried to introduce the pearl eye into them, but to the present time we have not seen any having so good a quality. In other respects they should be equal to those of other colours.

Barbs are hardy, docile, birds, flying but little when at liberty. As a rule, they are prolific breeders, but require assistance in bringing their young to maturity, as they generally seek fresh nests when their young are nine or ten days old, up to which time they feed well. We strongly recommend this variety to any who think of increasing their stock, as the Barb is not receiving so much attention as the bird deserves from the fancy at large.—BIRMINGHAM COLUMBIAN SOCIETY.

CLEAN-LEGGED WHITE BANTAMS.

In your Journal of September 1st, I wrote respecting White Bantams as being beautiful birds fast declining; we seldom see them in a class by themselves, still there are a few committees who hold out some encouragement for them. As Mr. Cambridge kindly remarked, they did not pay as a class. In my opinion we ought not to strike out a class from the prize sheet because it happens to be a failure in a pecuniary point of view; our prizes are offered, or should be, for the encouragement of the various breeds of poultry, and to aid in bringing them to the highest point of excellence. I say White Bantams pay as a class at some shows which I could name. They have a very respectable class at Newark and various other places, but in Scotland, I think, there are more classes for them than here. Mr. Cambridge wished "WHITE BANTAM" to communicate with him, and he would endeavour to retain the class for White Bantams at Bristol next Show. I am glad that communication has led to the result wished for, and that they will be tried there again.

My chief object in writing is to make known to all White Bantam friends and fanciers that we are to have a White Bantam class at Manchester Show, to be held, as usual, at Belle Vue. The prizes of £2 and £1 are offered in the prize list, which is being subscribed; but it is our intention to offer a silver cup for the first prize, the £2 offered as the second prize, and the £1 for the third prize. I have the pleasure to state that the following have already subscribed towards the above object—viz., "A Friend of White Bantams," 30s.; myself ("WURRE BANTAM"), 21s.; Rev. F. Tearle, 5s.; Mr. J. Watts, 10s.; and Mr. Edwin Pritchard, 5s. I cordially invite all fanciers to come forward with their subscriptions as soon as possible, so that we may have the prizes stated before the entries close. We know that Messrs. Jennison have one of the finest places in England for the purpose of a show, with an excellent staff of assistants. All, therefore, may rely upon their birds being well cared for in every respect, and returned, perhaps better than if they had stayed at home. Subscriptions for the above cup and class will be received by—SAMUEL J. ASHTON, *Roe Cross, Mottram, Manchester.*

HATFIELD BIRD SHOW.—I see that Ha'field again opens to the fancy, and I am sure, from the care taken of all our birds

last year, together with the improvement in the prizes and the low scale of entry fees, it should obtain the patronage of all my fellow fanciers. From a note received, I see all birds required, will be sent to Stockton by night mail for the show there the following day.—THOMAS FLETCHER.

SCARBOROUGH ORNITHOLOGICAL SOCIETY'S SHOW.

THE second annual exhibition of the Scarborough Society was held on Wednesday and Thursday, the 19th and 20th inst., and was a signal success with respect to both the number and quality of the birds staged. The Temperance Hall, the room in which the Show was held, is admirably adapted for the purpose, being well lighted, and, what is of the utmost importance, well warmed. So far as I could see, everything that prudence and forethought could devise had been done to secure a watchful attention to the stock, and it is at any time pleasing to be able to bear testimony to a fact which must secure the confidence of exhibitors generally, who, in sending valuable birds to any exhibition, place grave responsibilities in the hands of committees.

I shall confine my remarks to merely a slight review of the different classes, as time will not admit of my doing more, though I should have felt disposed, under more favourable circumstances, to have made my trip to Scarborough the text for a history of my "outing"—I think that's the word. A correspondent some short time back said he liked a visit to a show at a distance to assume the character of an "outing," and not merely to resolve itself into a statement of how A was first, and B was second. Another correspondent hit out straight from the shoulder, it was a shot, and said he did not care to read a column of extraneous matter, and then a half-dozen-lines notice of the show. It was something to that effect; I am only writing from memory. Many men have many minds, and among the thousands of readers into whose hands the "Journal" falls every Thursday, there will be as many who will take an interest in the "outing," as in the show. It takes many a reader home, too; and the greatest pleasure one has in writing is, that apart from a dry statement of facts which can interest comparatively few, there is the knowledge that some remark, some line or two, may make an otherwise dull page shine with a cheerful light. Every hobby is interesting to its own individual admirer, and if you love your hobby, make it as attractive as you can, and induce others to love it also.

Scarborough saw many new birds shown for the first time this season. To these more interest attaches than to birds of known character. Moore & Wynne brought out a splendid Clear Jonque Norwich, which had no difficulty in disposing of its opponents, Irons being a good second, with Simpson well up. Those who do not understand about Canaries will not know what all this means, and who Moore & Wynne, or Irons, or Simpson are. Well, I cannot help its being dry to you, it is not so to everybody. Some old fanciers (do you know what I mean by a "fancier?") will read it with immense interest. In Clear Buff Norwich, Moore & Wynne were first again, with a fine specimen, quite a star, and Simpson second with a good bird, which must visit the laundry before being sent out again. Good birds, if dirty, can never win against possibly inferior ones which are clean. When I say clean, I mean *clean*. In Evenly-marked Yellow Norwich, Mills's little wonder suffered defeat at the hands of one of the best Variegated Jonque Norwich I ever saw. It is a bird of good size and rich in colour, rather heavily but well marked. There is a very trifling difference in the absolute number of dark feathers in each wing, but it is quite unappreciable to the eye. The eye marks are rather heavy, but remarkably even in size and shape. What defects it may have, if it have any, it can afford to give away and still win. Mills's bird, however, is not yet quite fit, and what may be the result when they meet again I do not know. I hope it may be at Middlesbrough, where Mr. Barnesby is going to judge, to whose decision I shall look forward with much interest, and hope we shall have the pleasure of shaking hands. Moore & Wynne's bird, which was third, is beautifully marked, but though in faultless condition was deficient in colour. In Evenly-marked Buff Norwich, Moore & Wynne were first and second with two fine specimens, the first-prize bird being the same which won the silver cup at the Crystal Palace last Show. The Ticked classes contained, as they always do, some richly-coloured birds. The crests were extra good, including all varieties, Moore & Wynne being first with a fine marked and crested Buff cock. Mr. Calvert, of York,

showed a sweet hen, clear Buff with dark crest, which when more advanced will require some beating.

The less said about the Belgians the better, only one being in show condition, and it was by no means a bird of high character. A Buff bird (I think No. 106) shown in a Norwich show cage would have taken the first prize if it had had room to stand up. The Yorkshire classes were good. There was the usual sprinkling of Norwich among them, but the number is decreasing. The winners were good, Mr. Luke Belk, of Dawsbury, being first both in clear and marked birds. Lizards were both numerous and good, Mr. James Taylor, of Middlesbrough, and Mr. Mills, dividing the honours between them. Cinnamons were first-class, Mr. Irons taking both prizes with two Jonques, with excellent birds behind him. In "Any other variety," Sir W. H. Fielden was first with an immense bird, copy bred, but with a plain head—for immense read huge.

Evenly-marked Goldfinch Mules were a poor sample. Mr. Hawman and Mr. Stansfield showing the only two strictly in accordance with the schedule. Dark Mules were backward. Among twenty-six "cages of four," some nice birds were shown, forming a very attractive feature of the Show, Scarborough winning first honours in the person of Mr. Houghton. Linnet, Goldfinches, Skylarks, Bullfinches, &c., made up an interesting collection of British Birds, which I should like to see more extensively exhibited. And I saw other pretty birds at Scarborough!—W. A. BLAKSTON.

NORWICH.—Clear Yellow.—1, Moore & Wynne, Northampton. 2, T. Irons, Northampton. 3, R. Simpson, Whitby. Clear Buff.—1, Moore & Wynne. 2, R. Simpson. 3, R. Hawman, Middlesbrough. Evenly-marked Yellow.—1, R. Hawman. 2, E. Mills, Sunderland. 3, Moore & Wynne. Unevenly-marked Buff.—1 and 2, Moore & Wynne. 3, S. Tomes, Northampton. Tick'd and Unevenly-marked Yellow.—1, G. Mead, Scarborough. 2, Moore & Wynne. 3, R. Hawman. Tick'd and Unevenly-marked Buff.—1, T. Wales, Stockton-on-Tees. 2, G. Mead. 3, W. Darwell, Northampton. Crest'd.—1, Moore & Wynne. 2 and 3, T. Irons.

BELGIAN.—1, J. N. Harrison, Belper. 2, J. Shephard, Bradford. 3, T. Wales, Yorkshire. Clear Yellow or Buff.—1, L. Belk, Boston. 2, Mrs. J. Pearson, Beverley. 3, C. Dawsons, Beverley. Evenly-marked Yellow or Buff.—1, L. Belk. 2, J. Shephard. 3, S. Burton.

LAZARD.—Golden-spangled.—1, E. Mills. 2 and 3, J. Taylor, Middlesbrough. Silver-spangled.—1, J. Taylor. 2, F. Mills. 3, J. Barnes, York.

CINNAMON (Yellow or Buff).—1 and 2, T. Irons. 3, Moore & Wynne.

ANY OTHER VARIETY.—1, Sir W. H. Fielden, Scarborough. 2, Moore and Wynne.

GOLDFINCH MULE.—Evenly-marked.—1, R. Hawman. 2, E. Stansfield. 3, Lady Fielden. Dark.—1, Stevens & Burton, Middlesbrough. 2, E. Stansfield. 3, M. King.

CAFE OF FOUR.—1, C. Houghton, Scarborough. 2, R. Simpson. 3, J. Dawes, Scarborough.

ANY VARIETY OF BRITISH BIRD.—1, W. Harland, York (Bullfinch). 2, E. Stansfield, Bradford (Brambling or Mountain Finch). 3, O. Lawson, Scarborough (Goldfinch).

JUDGE.—Mr. W. A. Blakston.

BIRMINGHAM PHILOPERISTERON SOCIETY.

On the 25th and 26th inst. the fifth annual meeting of the above Society was held in the Athenæum Hall, Temple Street, Birmingham, and certainly public interest has never before been so completely enlisted nor better gratified; for although numbers of the visitors had travelled hundreds of miles solely to attend the Show, in every instance entire satisfaction was expressed at seeing not only one of the best collections of adult Pigeons, but likewise a competition of birds hatched in the present year that for their age have never been equalled. Almost every noted breeder of fancy Pigeons either sent birds for competition, or attended with the intention of purchasing fresh blood to improve his own stock. Perhaps one of the most noteworthy features of the whole Show was the *Bird* classes, the remarkably well-developed adults of Captain Heaton calling forth repeated expressions of admiration from all connoisseurs; nor were the young of this variety less remarkable for their perfection of condition and faultless characteristics. The *Carriers* were also admirably shown, and mostly in first-rate health and feather. *Fantails* were remarkably good, but several pens were sadly injured by packing in too small baskets. The Almond *Tumbler* shown by Mr. Adams, of B. Verley, were not bent in skull and in good feather, but the mode of selection of this gentleman's stock for *show alone* was open to improvement. *Tumbler*s were very fine, and the foreign ones were perfect gems. Some first rate English Owls were also on view. The *Turkots* were the best collection of high-class birds ever shown in Birmingham, and a remarkable feature was that every colour was well represented. For *Dragoons* the meetings of this Society always ranked high, and on this occasion so perfect were they, that one of the oldest exhibitors admitted it was almost impossible to hope for success in such competition, that he was glad he had seen them, for he should have been hopelessly dead had he entered his birds, which he had hitherto considered invincible. The *Intervary*s certainly did not develop so much character as at some previous meetings, many being sadly too long in head and spare in bill.

In the classes for flying *Tumbler*s the improvement was very marked indeed, more particularly in the matching to feather of the birds, and the perfect condition in which they were penned. In *Yellow Dragoon*s the cup fell to the pen 262, shown by Mr. Frank Graham; they were, perhaps, one of the most faultless pens ever exhibited, and for colour

quite unexceptionable. In Class 60, for a single Pigeon of any variety, Captain Heaton pretty well swept the board in a heavy class, taking the first, second, third and sixth prizes with excellent Barbs, and also the fifth with an English Blue Owl of great merit; Mr. Harry Adams, the only other successful exhibitor in this class, having a really sound-leathered Almond. Mr. Yardley exhibited two cages of excellent Carriers and Almonds, of about twelve birds each, not for competition, which added much to the attractions of the Show.

The *Fancy Toys* were public favourites; and when we state *Satinettes*, "Bluettes," quite a new and exceedingly chaste variety, *Lahores*, *Scandarooms*, *Maned Pigeons*, *Egyptian Swifts*, *Isabels*, *Archangels*, *Starlings*, *Priests*, and *Shields*, were all well shown, it is scarcely to be wondered that six prizes were awarded, and certainly as many more might have been with justice given.

BIRDS OF 1870.

CARRIERS.—Black.—1 and 3, F. Smith, Selby Oak. 2 and 4, R. W. Nightingale, Aston. *he*, J. Linnett, jun., Coventry; R. W. Nightingale. *Dun*.—1, G. F. Whitehouse, King's Heath. 2, J. Watts, King's Heath. 3 and *he*, J. Coleman, West Bromwich. *Any other Colour*.—1 and 2, G. Hodgkinson, Erdington. 3, J. Watts.

POULTERS.—1, 2, and 3, G. Sturgess, Leicester. FANTAILS.—1, G. Sturgess. 2, J. F. White, Birmingham. 3, H. Adams, Beverley. 4, J. W. Edge, Birmingham. 5, Mrs. A. F. Barnett, Erdington. *he*, H. J. Massey, G. Sturgess.

ALMONDS.—1 and 2, H. Adams. 3, G. F. Whitehouse. BALDS AND BEARDS.—1 and 3, F. Graham, Birkenhead. 2, J. W. Edge. SHORT-FACED (Any other variety).—1, H. Adams. JACOBI'S.—1 and 2, J. W. Edge.

TROMPETERS.—1, T. Robson, Penkridge. 2, J. Watts. 3, J. F. White. OWLS.—Foreign.—1 and 2, H. Adams. English.—1, G. Linnett, jun. 2, J. W. Edge. 3, G. F. Whitehouse.

TUMBLERS.—1, G. F. Whitehouse. 2, W. Bankes, Runcorn. 3, T. Robson. 4, F. H. Paget, Leicester. BARBS.—1, 2, Capt. H. Heaton, Worsley, Manchester. 3, G. Sturgess. NUNS.—1 and 2, W. Bankes. 3, F. Graham.

DRAGONS.—Blue.—1 and 2, J. Coleman. 3, 4, 5, and *he*, F. Graham. 6, J. Watts. Yellow.—1, 2, and 3, F. Graham. White.—1 and 2, H. Adams. 3, F. Graham. *he*, G. F. Whitehouse. *Any other Colour*.—1, 2, and 3, F. Graham.

ANSWERERS.—1, 2, and 3, G. F. Whitehouse. 4, G. F. Whitehouse. 5, F. Graham. ANSWERS.—1, 2, and 3, G. Muzg, Bromsgrove. 3, H. Cluice, Birmingham. *he*, W. Bankes; F. Smith.

SWALLOWS.—1 and 2, F. H. Paget. 3, G. F. Whitehouse. ANY OTHER VARIETY.—1, W. Bankes (*Satinette*). 2, 4, and *he*, F. H. Paget (*Bluette*, *Satinette*, and *Scandaroom*). 3, J. Watts.

TUMBLERS.—Black Buds.—1 and 2, G. Hodgkinson. Blue Buds.—1, J. W. Edge. Black Saddles.—1, J. W. Edge. Blue Saddles.—No prize awarded. *Any other Colour Saddles*.—1, J. W. Edge. *Bobwings and P. Parrots*.—1, 2, and 3, J. Massey, Aston. *Bottles*.—Prize withheld. *Any other Variety*.—1, J. W. Edge.

BIRDS OF ANY AGE.

CARRIERS.—Black.—Cocks.—1, 3, and Cup, G. F. Whitehouse. 2, J. F. White. *he*, R. W. Nightingale. Hens.—1 and 2, F. Smith. 3, R. W. Nightingale. *Dun*.—Cocks.—1, F. Smith. Hens.—1, F. Smith. 2, G. F. Whitehouse. *he*, J. Watts. *Any other Colour*.—Cocks.—1, G. Hodgkinson. 2, J. Watts. Hens.—1, R. W. Nightingale. 2, J. Watts.

POULTERS (Cocks).—1, 2, and Cup, G. Sturgess. 2, H. Adams. Hens.—1 and 2, G. Sturgess. 3, H. Adams. FANTAILS.—1, G. Sturgess. 2, Mrs. A. F. Barnett. 3, F. Smith. *he*, G. F. Whitehouse.

ALMONDS.—1 and 2, H. Adams. BALDS AND BEARDS.—1, J. Fielding, jun., Rochdale. 2, F. Graham. SHORT-FACED (Any other Variety).—1, T. Robson.

JACOBI'S.—1, G. Sturgess. 2, J. Linnett, jun. TROMPETERS.—1, T. Robson. 2, J. Massey. *he*, J. Watts.

OWLS.—Foreign.—1, J. Fielding, jun. 2, H. Adams. English.—1, J. W. Edge. 2, Capt. Heaton. 3, J. Watts. *he*, W. Bankes; G. F. Whitehouse.

TUMBLERS.—1, T. Robson. 2, W. Bankes. 3, F. Graham. *he*, T. Robson; G. F. Whitehouse; J. Watts.

BARBS.—1, 3, and Cup, Capt. Heaton. *he*, G. F. Whitehouse; J. Fielding, jun. NUNS.—1, F. Graham. 2, W. Bankes.

DRAGONS.—Blue.—1, 2, and 3, F. Graham. Yellow.—1, Cup, and *he*, F. Graham. 2, J. Watts. White.—1 and 2, F. Graham. 3, H. Adams. *he*, J. Watts. *Any other Colour*.—1, F. Graham. 2, J. Watts. 3, G. Hodgkinson.

MAINTERS.—1, T. Robson. 2, F. Graham. ANSWERS.—1, J. E. Cleveland. 2, F. Smith. 3, H. Cluice.

SWALLOWS.—1, J. Watts. 2, G. F. Whitehouse. ANY OTHER VARIETY.—1 and Cup, W. Bankes (*Satinette*). 2 and 6, G. Sturgess. 3, F. H. Paget. 4, J. Watts (*Manch*). 5, J. Linnett, jun. (*Isabels*).

ANSWER COCKS.—1, 2, and 3, G. Muzg. ANY OTHER FANCY VARIETY.—1, 2, 3, 5, and 6, Capt. Heaton (*Barbs and English Owl*). 1, H. Adams. *he*, W. Bankes (*Bluette*); F. H. Paget.

TUMBLERS.—Black Buds.—1, J. Massey. 2 and 3, G. Hodgkinson. Blue Buds.—1, J. W. Edge. Blue Saddles.—1 and 2, G. Hodgkinson. *Any other Coloured Saddles*.—1, G. Hodgkinson. 2, J. W. Edge. *Bobwings and Red-banks*.—1, J. Massey. *Any other Flying Variety*.—1, J. Massey. *Any other Variety*.—1, J. W. Edge. 2, J. Massey.

Mr. Edward Hewitt, Mr. Henry Yardley, and Mr. Wm. Walthew, of Birmingham, were the Judges.

SHEFFIELD ORNITHOLOGICAL SOCIETY'S SHOW.

The first annual Exhibition of this Society was held from the 21st to the 24th inst. The attendance was not so large as desirable, but considering the bad weather, there was not much fault to find. The Show was very attractive, and the room was well ventilated and heated, making the specimens warm and comfortable.

Pigeons.—Carriers.—1, W. H. Mitchell. 2, W. Harvey. *he*, E. C. Streech. *Pouters*.—1 and *he*, W. Harvey. 2, E. Brown. *Barbs*.—1, W. Harvey. 2, H. Yardley. *Tumbler*s.—1 and 2, W. Harvey. *he*, E. Brown; H. Yardley. *Jacobins*.—1 and 2, W. Harvey. *he*, J. Smithers; H. P. Ryland. 3, F. Brown. *Fantails*.—1, J. F. Lovesidge. 2, W. Harvey. *Doves*.—1 and 2, W. Harvey. *Kunts*.—1, H. Yardley. *Nuns*.—1, H. Yardley. 2, W. Harvey. *Dragoons*.—1, A. W. Wren. 2, W. Harvey. *Muffs*.—1, W. Harvey. 2, H. Yardley. *Trumpeters*.—1 and 2, W. Harvey. *Any other Variety*.—1, W. Harvey. 2, G. Cutler.

CANARIES.

BELGIAN.—Yellow.—1, P. Rawnsley. 2, F. Mills. *he*, S. Radford. Buff.—1, W. Clark. 2, H. Clark. *he*, Rawnsley. *Varietated Yellow*.—1, L. Belk. 2, J. N. Harrison. *Varietated Buff*.—1 and 2, J. N. Harrison. NORWICH.—Yellow.—1, Moore & Wynne. 2, S. Bunting. Buff.—1, Moore and

Wynne. 2, S. Bunting. *Varegated Yellow.*—1, S. Bunting. 2, Moore & Wynne. *Varegated Buff.*—1, W. Clark. 2, Moore & Wynne.
 LIZARD.—*Gold-spangled.*—1, J. Taylor. 2, S. Bunting. *Silver-spangled.*—1 and 2, S. Bunting.
 CANNON (Varegated).—1, Stephens & Burton. 2, Moore & Wynne.
 DUCKS.—1, S. Bunting. 2, T. Keys.
 MOST PERFECT MARSH.—1, S. Bunting. 2, Stevens & Burton.
 RABBITS.—*Length of Ear.*—1, C. King. 2, C. Gravel. Thorne. 3, J. Priestly. *Black and White.*—1, C. King. 2, and he, J. Lee. *Blue and White.*—1 and 2, T. Gelder. *hc.* C. Gravel. *Yellow and White.*—1, C. King. 2.—Vaughan. *hc.* C. Gravel. *hc.* W. Nixon. *Grey and White.*—1, T. Gelder. 2, J. Lee. *hc.* C. King; J. Parker. *hc.* E. Rawlinson; —Vaughan. *Tortoiseshell.*—1, C. King. 2, J. Lee. *hc.* A. J. Rawstron. *hc.* G. Betts. *Self Colour.*—1, G. C. Sykes. 2, C. Gravel. *Heaviest.*—1, T. Mumby. 2, S. Butterworth. *hc.*—Vaughan. *hc.* C. Gravel. *Foreign Variety.*—1, E. E. M. Roysds. 2, A. G. Rawstron. *hc.* H. Carwood; C. Gravel.

JUNCOS.—*Pigeons:* Mr. James Smith and Mr. Henry Brown, of Walkley. *Canaries:* Mr. George Tuckwood, Nottingham. *Rabbits:* Mr. Grindley, Sheffield.

EXPERIMENTS WITH FOUL BROOD.

I HAVE this autumn been amusing myself with experiments in the way of foul brood, and I regret that some one more able than I am has not taken up the subject, as I find myself incompetent clearly to explain the results of the experiments which I have made. These experiments were undertaken in order to prove the fungoid theory, and to my own satisfaction I have proved it; but, as I have already said, I am not able to describe them in technical terms, nor to make common terms supply the place of technical ones. I will, therefore, merely describe one experiment, which may, I hope, stimulate others. It was my last essay, and was made by taking two half-cupfuls of sweet milk, and impregnating one-half with a modicum of foul-broody matter about the size of a No. 1 lead shot. In twelve hours the one impregnated became sour, and in forty-eight hours the curd was separated from the whey, and in a few hours a fungus like a vinegar plant became visible on the surface of the whey. At the end of two weeks it became a very thick gelatinous substance, the curd all this time remaining sweet. At the end of three weeks acetous fermentation and putrefaction set in, and there was visible round the edges a yellow substance, the smell, though stronger, being not unlike that of foul brood, and when viewed through a microscope millions of spores were seen, similar to those of foul brood. The other half-cupful of milk underwent no change further than that which happens in ordinary sour milk.

These experiments, although they may not instruct your readers, will, I hope, be the means of stimulating others to solve the problem of what at this moment not only threatens to destroy insect but human life.—A LANARKSHIRE BEE-KEEPER

POST ENTRIES AT CANARY SHOWS.—Newcastle has, as may be seen from our advertising columns, extended the time of making entries. We think it well, as the time between the close of entries and the Show is unusually long. But would it not have been better to have named a reasonable time, and so have obviated this necessity?

OUR LETTER BOX.

BAILY'S PILLS (Isa).—Write to Messrs. Baily, 113, Moimt Street, Grosvenor Square, London, W.

MONMOUTH SHOW (T. A. D.).—As the Committee did not think it of sufficient importance to advertise, we conclude it was not worthy of special notice. Committees may do well to consider this extract from your letter:—"I frequently see in your paper notices of shows that have not been advertised previously, which prevented me from exhibiting many times this season. This I should have done had I known there was a show at such and such places."

TUNDRIDGE WELLS POULTRY SHOW.—We are informed that the commended pen of Spanish chickens belonged to Mr. J. Francis, and not to Mr. Hose.

SILKIES FIVE-CLAWED (M. A. F.).—It is not a blemish. So far from it, the five claws are often found on the best specimens. It must be clearly understood, that in showing a pen the birds of which it is made up must all have the same number of toes, whether four or five.

SWELLING UNDER A HAMBURG'S EYE (Northern Subscriber).—Your bird is suffering from cold, and if neglected this will turn to roup. Wash the feet well with cold water and vinegar. Give him Baily's pills, and camphor pills once or twice per day, according to the symptoms. He wants watching closely this damp weather, when the symptoms become aggravated quickly. Both huckle and saddle of a Silver-spangled cock should be perfectly clear, but the principal feathers should be tipped with black.

ROUEN DUCKS' PLUMAGE (F. G. S. R.).—We cannot quite understand your question. All Rouen Ducks should be the colour of wild Ducks and they are always dark. We consider light plumage a defect, and any white is inadmissible, save the ring round the drake's neck; this should be small.

ALMOND TUMBLERS (A Subscriber).—We cannot recommend anyone. Write to Mr. J. W. Ludlow, Secretary, Columbarian Society, Vauxhall Road, Birmingham, and ask him. Enclose a stamped and directed envelope.

FANTAILS LAYING AND SITTING BUT NOT HATCHING (J. P. Davies).—Your place for your Pigeons is suitable. If the eggs are clear at a week's end, shine them up by a candle and you will see; then it is the male bird's fault—he is too old. This is the most probable cause. If the eggs are fertile, they may have rolled from under the hen, or been in some other way chilled. You, of course, make a nice concave nest of straws cut 2 or 3 inches long. Bread and potatoes are not fit for staple food for Pigeons, but they peck a little now and then with relish. Oats are not good either.

POLE-HOUSE FOR PIGEONS (An Old Subscriber).—A pole-house in the middle of a yard, unsheltered from the wind, is an unsuitable abode for Pigeons in the winter, and it would be much better to find out some corner of a loft over a stable, &c. All pole-houses, however situated, are cruel places to force Pigeons to live in. The birds are scorched to death in the summer, frozen in the winter, and are usually of little profit to the owner, as there is no fit nest secure against wind and rain in which to rear their young; while, on the contrary, if but 2 feet deep within a building can be given them, with holes outside to match each division of the inner woodwork, full success may be looked for, and the birds have a comfortable home. There must be a landing-board outside such building level with every row of holes.

TURTLE DOVES (Bullfinch).—They should be entered as British birds.

PRESERVING PLUMS WITHOUT SUGAR.—Take any kind of plum (if not quite ripe all the better), gather them when dry, wipe each fruit, place them in wide-necked bottles, then tie over the mouth of each bottle two pieces of bladder separately—i.e., at two tyings. Place the bottles in a boiler in cold water up to their necks with bay to keep them from jarring. Boil till the plums begin to swell, say fifteen or twenty minutes, take off the boiler, and let the bottles remain in it till cold, then remove the bottles to a dry closet, where they may remain for one or two years always fresh and good.

METEOROLOGICAL OBSERVATIONS

In the Suburbs of London for the week ending October 25th.

DATE.	BAROMETER.		THERMOMETER.				Wind.	Rain
	Max.	Min.	Air.		Earth.			
			Max.	Min.	1 ft.	2 ft.		
Wed. . . 19	29.549	29.283	62	40	51	50	S.	.46
Thurs. . 20	29.448	29.354	54	36	51	50	S.W.	.16
Fri. . . 21	29.893	29.776	61	36	51	50	N.W.	.09
Sat. . . 22	29.808	29.500	61	47	52	50	S.	.34
Sun. . . 23	29.932	29.844	58	42	53	50	W.	.20
Mon. . . 24	29.424	29.255	60	36	52	50	W.	.00
Tues. . . 25	29.450	29.362	54	40	51	50	S.W.	.00
Mean. .	29.618	29.432	58.57	39.57	51.57	50.00	..	1.16

- 19.—Heavy rain; densely overcast, stormy; boisterous.
- 20.—Cloudy; showery; stormy with rain.
- 21.—Fine; very fine; densely overcast.
- 22.—Cloudy but fine; densely overcast; showery.
- 23.—Rain; showery; clear and fine at night.
- 24.—Densely overcast; showery; brilliant aurora borealis 8 P.M.; clear and fine.
- 25.—Fine but cloudy; fine; aurora borealis 6.30 to 8.30 P.M.; fine and clear.

COVENT GARDEN MARKET.—OCTOBER 26.

We have a fair attendance of buyers, but business generally is far from encouraging, there being a great excess in the supply, and prices remaining nearly stationary. The Potato trade has improved, and there has been a slight advance in the first qualities. Pears comprise Marie Louise, Glou Morceau, Duchesse d'Angouleme, and Bauré Clairegain, with inferior varieties; Apples, Ribston Pippin, Cox's Orange Pippin, Blenheim Pippin, Kerry Pippin, and Fearo's Pippin.

FRUIT.

	s.	d.	s.	d.		s.	d.	s.	d.
Apples.....	½	sieve	1	0	2	0	0	0	0
Apricots.....	doz.	0	0	0	0	0	0	0	0
Chesnuts.....	bushel	6	0	13	6	0	0	0	0
Cherries.....	lb.	0	0	0	0	0	0	0	0
Currants.....	½	sieve	0	0	0	0	0	0	0
Black.....	doz.	0	0	0	0	0	0	0	0
White.....	doz.	2	0	3	0	0	0	0	0
Fiberts.....	lb.	1	0	2	0	0	0	0	0
Cobs.....	lb.	1	6	2	0	0	0	0	0
Gooseberries.....	quart	0	0	0	0	0	0	0	0
Grapes, Hothouse.....	lb.	2	0	5	0	0	0	0	0
Lemons.....	£100	10	16	0	0	0	0	0	0
Melons.....	each	1	0	4	0	0	0	0	0
Mulberries.....	lb.	0	0	0	0	0	0	0	0
Nectarines.....	doz.	0	0	0	0	0	0	0	0
Oranges.....	£100	20	0	0	0	0	0	0	0
Peaches.....	doz.	4	0	12	0	0	0	0	0
Pears, kitchen.....	doz.	1	0	2	0	0	0	0	0
Pears, dessert.....	doz.	1	0	3	0	0	0	0	0
Pine Apples.....	lb.	2	0	5	0	0	0	0	0
Plums.....	½	sieve	1	6	3	0	0	0	0
Quinces.....	doz.	1	0	0	0	0	0	0	0
Raspberries.....	lb.	0	0	0	0	0	0	0	0
Strawberries.....	lb.	0	0	0	0	0	0	0	0
Walnuts.....	bushel	10	0	16	0	0	0	0	0
do.....	£100	1	0	2	0	0	0	0	0

VEGETABLES.

	s.	d.	s.	d.		s.	d.	s.	d.
Artichokes.....	doz.	0	0	0	0	0	0	0	0
Asparagus.....	£100	0	0	0	0	0	0	0	0
Beans, Kidney.....	½	sieve	0	0	0	0	0	0	0
Broad.....	bushel	0	0	0	0	0	0	0	0
Beet, Red.....	doz.	2	0	0	0	0	0	0	0
Broccoli.....	bundle	0	9	1	6	0	0	0	0
Brussels Sprouts.....	½	sieve	3	0	4	0	0	0	0
Cabbage.....	doz.	1	0	2	0	0	0	0	0
Capiciums.....	£100	1	0	1	6	0	0	0	0
Carrots.....	bunch	0	4	0	0	0	0	0	0
Cauliflower.....	doz.	2	0	6	0	0	0	0	0
Celery.....	bundle	1	6	2	0	0	0	0	0
Coleworts.....	doz. bunches	3	0	6	0	0	0	0	0
Cucumbers.....	each	0	6	1	0	0	0	0	0
pickling.....	doz.	2	0	4	0	0	0	0	0
Endive.....	doz.	2	0	0	0	0	0	0	0
Fennel.....	bunch	0	8	0	0	0	0	0	0
Garlic.....	lb.	0	8	0	0	0	0	0	0
Herbs.....	bunch	0	8	0	0	0	0	0	0
Horseradish.....	bundle	8	0	6	0	0	0	0	0
Lettuce.....	bunch	9	4	0	0	0	0	0	0
Mushrooms.....	pot	1	0	2	0	0	0	0	0
Mustard & Cress.....	punnet	0	2	0	0	0	0	0	0
Onions.....	bushel	4	0	6	0	0	0	0	0
pickling.....	quart	0	4	0	0	0	0	0	0
Parsley.....	sieve	8	0	0	0	0	0	0	0
Parsnips.....	doz.	0	9	0	0	0	0	0	0
Peas.....	quart	0	0	0	0	0	0	0	0
Potatoes.....	bushel	2	0	4	0	0	0	0	0
Kidney.....	do.	9	0	0	0	0	0	0	0
Radishes.....	doz. bunches	0	0	0	0	0	0	0	0
Rhubarb.....	bundle	0	0	0	0	0	0	0	0
Savoys.....	doz.	0	0	0	0	0	0	0	0
Sea-kale.....	basket	0	0	0	0	0	0	0	0
Shallots.....	lb.	0	0	0	0	0	0	0	0
Spinach.....	bushel	2	0	2	0	0	0	0	0
Tomatoes.....	doz.	1	0	1	6	0	0	0	0
Turnips.....	bunch	0	0	0	0	0	0	0	0
Vegetable Marrows.....	doz.	2	0	3	0	0	0	0	0

WEEKLY CALENDAR.

Day of Month		Day of Week		NOVEMBER 3-9, 1870.			Average Temperature near London.			Rain in last 43 years.	Sun Rises.	Sun Sets.	Moon Rises.	Moon sets.	Moon's Age.	Clock after Sun.	Day of Year.	
					Day.	Night.	Mean.	Days.	m.	h.	m.	h.	m.	h.	Days.	m.	s.	
3	TH	Meeting of Linnean Society, 8 P.M.			53.5	35.9	44.7	19	59	af 6	29	af 4	24	af 3	14	af 1	10	16 18 307
4	F				52.1	36.6	44.3	22	0	7	27	4	41	3	23	2	11	16 18 308
5	S				52.9	37.2	45.0	20	2	7	25	4	59	3	30	3	12	16 16 309
6	SUN	21 SUNDAY AFTER TRINITY.			51.4	38.9	44.7	19	4	7	24	4	17	4	37	4	13	14 14 310
7	M	Twilight ends, 6.11 P.M.			52.1	36.7	44.4	20	5	7	23	4	34	4	43	5	14	16 11 311
8	TU	Length of Day, 9h. 15m.			52.0	34.3	43.1	19	7	7	22	4	54	4	49	6	15	16 7 312
9	W	Meet. of Royal Microscopical Society, 8 P.M.			50.5	33.8	42.2	16	9	7	20	4	18	5	55	7	16	16 2 313

From observations taken near London during the last forty-three years, the average day temperature of the week is 52.2°, and its night temperature 35.9°. The greatest heat was 63°, on the 5th and 6th, 1834; and the lowest cold 17°, on the 9th, 1864. The greatest fall of rain was 1.02 inch.

NOTES MADE DURING A TOUR IN IRELAND.

No. 1.



IRELAND, our fair sister—the green, the Emerald Isle!—we gardeners of England know little of your land, and yet Ireland is very near to us, and very dear to us. Dublin is but eleven hours from London, and yet Ireland is too little known to us, and less understood. Why is this? It would indeed be difficult to tell. There is but a narrow strip of water that divides us, and yet we hesitate to pass across. Many of us, although we boast of our supremacy of the seas, have still a secret dread of sea sickness—of the horrors of crossing the proverbially shaly Irish Channel, and so many of us remain at home, and remain ignorant of the beauties of lovely Ireland, and of the warm hearted natures of the Irish people.

We are all pretty well informed that Dame Nature has been wondrously bountiful to the Irish Isle, endowing her with a genial climate and with rich and fertile soils. We have, however, but a poor knowledge of what that really means, or of the vast magnitude of the capabilities of the country. It requires seeing her to understand.

We, in England, have strange and crude notions that Ireland is a land half desolate and neglected—centuries behind our own—with a people poor, oppressed, and discontented—with landlords harsh and tyrannical, screwing the life-blood out of the land! Can there be greater delusions? We read at times, it is true, some sad accounts of the bad feelings existing between landlord and tenant, but these are very exceptional, and in no way compromise the great body of the people, landlords or tenants. As for the Irish landlords, take them as a class, I believe them to be extremely indulgent. It having been my fortune lately to visit many of their establishments I say this much candidly, that they contrast very favourably with our own in many ways. There are numerous exceptions, of course, and the worst of all are the absentees, a class which are far too common.

Are the people oppressed? No, decidedly not. Are they poor? No. Although they seem so in their miserable hovels of dwellings, and their dirty tattered garments, yet they are by no means poor. Speak of poverty in Ireland and you give deep offence; besides, it is not true. Work is plentiful in Ireland, and workmen scarce. Wages are generally as high as in this country—from 2s. to 3s. per day, and during harvest far higher, with many accompaniments which the labouring class of this country do not have.

Is Ireland poor? This cannot be when the farmers of Ireland have been able to lay by within the last few years, as stated from official returns, several millions of money. Are the people discontented? This cannot be denied, yet I hope the causes are fast being removed, for a more joyous, hearty, kind-hearted people does not exist; but into this it is not my business to inquire—my object in visiting Ireland was to observe its gardens and gardening.

In passing through the country I could not help noting

everywhere the extremely well-made and well-kept roads, under the care of Government, I believe, and how extremely appropriate is the title of the green and Emerald Isle! for green it is in truth. Such depth of verdure, such extent of landscape, all of the most lovely green, nowhere have I seen except in Ireland. How vivid, how marked was the contrast of the beautiful green and rich grassy meadows, and the lovely green trees, to those of our own country this season! Whilst we in England have been parched up—almost without a blade of green—in Ireland vegetation was triumphant—grass abundant, root crops, Turnips, Potatoes, chief of Ireland's food, everywhere most excellent. The great extent of rich pasture land in some of the counties, as in Meath and Kildare, is something marvellous, entire and immense tracts of land being like one vast grazing field, broken only by the hedgerow trees. We envy Ireland also her charming lakes and their rich and lovely scenery, the magnificence of her trees and tree landscape, and the grand and extensive parks which surround the seats of her landed nobility. Widely apart as these seats may be the one from the other, they nevertheless present considerable uniformity of character. The various sites are remarkably well chosen, giving most extensive views of the surrounding district.

The style of the mansions is in general plain Elizabethan and baronial, with most extensive and well-designed parks and gardens. The parks and the trees around the Irish nobleman's abode are quite features of the country. The gardens, too, seem to have been laid out originally with considerable skill and taste, and generally on an extensive scale. I do not speak here of hothouses, which belong more to the present age, but of the art of landscape gardening and designing, and I feel bound to observe that there are evidences in these old places of a fully higher calibre of gardening than is common at the present day. I met with many exceptions, of course, which I shall duly notice, yet I could by no means blink the fact that gardening in Ireland, as in our own country, is running too much in one groove, and, to my mind, that groove is a very narrow one. There is a growing tendency for having all things under glass, for expensive stove and hot-house plants, for staring ribbon borders, and great blazes of gaudy colour, instead of quiet beauty of form and simple elegance. In our rage after all this we are forgetting much that is pleasing and lasting in the beauty of our hardy plants and trees, which give such universal and continuous pleasure.

Of the principal features of Irish gardening I would just notice the unusually fine collections of stove and fine-foliaged plants, and the general excellence of the specimens, with the apparent great interest taken in their cultivation. I met with these in very unexpected places. In many establishments I fancied the same means would have been far better expended elsewhere—whether these were pet subjects of the employers or of the gardeners I cannot say. It struck me, however, as ill-regulated in several instances where the employers reside but little, and where labour seemed to be sadly scant—with fruits and other more permanent subjects greatly neglected—to

discover so many of these expensive plants. In our stove and ornamental-foliaged plants we have, no doubt, the most beautiful forms of vegetation, and being so, I think they should be but sparingly introduced, or not at all, unless the other portions of the garden are in harmonious keeping. In such places as Powerscourt and Mr. Bewley's, at Blackrock, the hot-house plants formed a fine feature in perfect harmony with the whole; but I see no beauty in stove plants which have to be reached through other portions of the gardens much neglected.

The modern style of flower gardening in Ireland is following much in the same direction as in England—endless bands and stripes of gaudy colours. We cannot but admire such blazes as we sometimes see, when well done, but too often they are extremely repulsive. At Mount Merrion, near Dublin, the display of tricolor and bronze Pelargoniums was magnificent in the extreme, far exceeding in their brilliant colourings and general effectiveness anything I could have anticipated in the flower garden. With us bronze Pelargoniums planted out of doors are in general dingy and dull, but at Mount Merrion they were more brilliant than we have them under glass. Possibly a good deal of this superior excellence may be attributed to the more soft and gentle humid atmosphere of Ireland, which is more favourable to leaf-development and coloration than our own climate.

I must here enter a word of protest against the employment of coloured-leaved Beet amongst flowers to such an inordinate extent as was the case in Ireland. Nothing, possibly, could have shown worse taste than in many of the instances where it was used. The plant has a very striking and unique appearance, and should be used sparingly. I do not object to its use now and then. It is well adapted for mixing with other fine-foliaged plants in large beds, as against the white-leaved Centaurea, or even the yellow Pyrethrum; but, as I observed it in several instances in small beds along with Verbenas, Mrs. Pollock Pelargonium, &c., it had a most detestable appearance. The dry season had in several instances prevented the other occupants from growing to any considerable size, so that the dark-coloured leaves of the Beet, which seemed to thrive everywhere, gave some of the gardens around Dublin the appearance of fields of Mangold. A far finer plant having much the same colour of leaf, and which seems particularly well suited for Ireland, is the Iresine Lindenii. The older variety, I. Herbstii, seemed in Ireland to take the place of Colens Verschoffelti with us, which I was rather surprised to find does not succeed in Ireland; at all events I only saw it on one or two occasions.

The Zonal Pelargoniums seemed to find a happy home in Ireland, and one of the most telling and favourite varieties was no other than Amy Hogg, her pleasant lively face lighting up many an Irish garden.

The great number of Irish Yews, studded over the Irish gardens like military sentinels in their unbending stiffness, was also another feature that attracted my attention. At Carton, Maynooth, they were grand and imposing.

Fruits are on the whole not quite so well represented as I had expected to find them. Grapes were in many places extensively grown and well, although I saw nothing sensational. Pine Apples seemed to be but little grown; at all events I saw few in my travels. Peaches were, as a rule, excellent and well cultivated. Orchard houses seemed to be at a low discount since Mr. Bewley's famous ones have succumbed. Outdoor fruits were extremely abundant, and in many gardens I found very fine collections. Pears on pyramids in the gardens round Dublin were very fine. If a little more attention were paid, Ireland would be a great fruit-producing country. In many districts the climate is very similar to that of Jersey, where the very finest fruits are grown.

My too-short tour in Ireland was an extremely pleasant one, for I met with many—very many—kind friends, although I met them as a comparative stranger. Talk of freemasonry! why, the feeling of brotherhood amongst gardeners is far exceeding that of any other class. We find ourselves at home everywhere, yet nowhere have I found a welcome so warm as in the Sister Isle. Much—indeed I suspect a very great deal—of this overflowing kindness I owe to the high respect in which my introducer, Mr. James Robertson, of Dublin, is held. I owe to this gentleman many thanks for his valuable assistance in enabling me to see so much of his adopted country.

My tour was confined to the gardens around Dublin, in the counties Wicklow, Kildare, &c., and from that northwards to Enniskillen and Belfast. I will furnish your readers with more detailed notes on the more remarkable of the places I visited;

and I add as my opinion, that if in Ireland there are not so many fine gardens as in England, yet they will bear comparison with advantage in many respects.—B.

GROUND LEVELLING AND PRACTICAL GARDEN PLOTTING.—No. 3.

DRAWING PLANS.

HAVING given a short description of such materials as will be necessary for a beginner, I will proceed to apply them to their uses, commencing with fig. 6.

1. *To Bisect a Given Line.*—Draw the line *AB* (fig. 6). Use the compasses having a pencil leg. Put the steel point of the compasses in point *A*. Open the compasses until the distance is greater than the half of the line *AB*, and with the pencil describe the arc *dd*. Shift the steel point of the compasses to point *B*, and with the same radius draw the arc *cc*. The

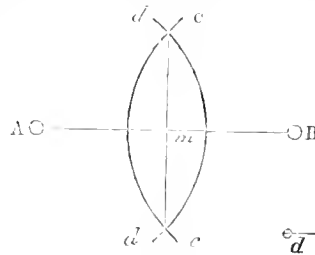

Fig. 6.

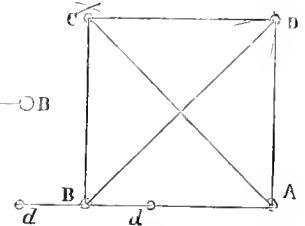

Fig. 7.

points where the two lines cut each other, as in *d, c*, are perpendicular to or square with the line *AB*. Draw a line from the points of intersection—that is, from point *d, c*, to point *d, c*, and it will bisect or cut the line *AB*, into two equal parts, as at *m*.

2. *To Describe a Square on the Line AB.*—The line *AB* (fig. 7) is 1 inch in length, and represents 8 feet, being drawn to the scale of 8 feet to the inch. Erect a perpendicular line from point *B*, which is done in the following manner:—Take any two equal distances from point *B*, say the points *dd*; place the steel point of the compasses in point *d*; open the compasses until the radius is greater than *dd*; then with the pencil describe an arc, as in *c*. Shift the steel point of the compasses to the other point *d*; describe another arc, cutting the former one, as in *c*; draw the line *BC*, taking care it is as long as the line *AB*. Two sides of the square are now drawn, and *A* and *C* are centres. Place the steel end of the compasses in point *A*; open them until the pencil will just meet point *B*; and turn the compasses round and describe an arc, as in *D*. Then shift the steel point of the compasses to point *C*, and with the same radius describe another arc in *D*, cutting the former one; next draw the lines *CD*, and *DA*, and the square is formed. To prove the square, if the diagonal lines *AC*, and *BD*, are exactly equal in length, the square is perfect.

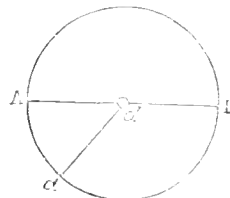

Fig. 8.

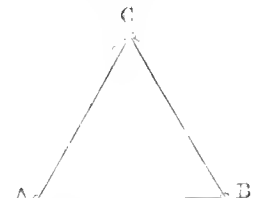

Fig. 9.

3. *To Describe a Circle.*—The diameter *AB*, being given—say 8 feet—find the half (4 feet); with the half as radius (*da*) describe the circle (fig. 8) with the compasses.

4. *To Form an Equilateral Triangle.*—The base line *AB* (fig. 9) is 8 feet. Find 8 feet on the scale. With the compasses from *A* and *B* describe two arcs, cutting each other in *c*. Draw a line from *A* to *c*, and from *c* to *B*, and the triangle is complete.

5. *To Construct an Oval on a Given Line.*—The line *AB* (fig. 10) is 8 feet in length. With half the line, *o*, as radius describe a circle. From *A* and *B* as centres draw arcs, with the radius *AB*, cutting each other in *E*. From *E* draw the line

E, c, c, which will bisect the line A B, in o, and also cut the circle in D. With D as a centre describe the arc ee, meeting the arcs drawn from A and B.

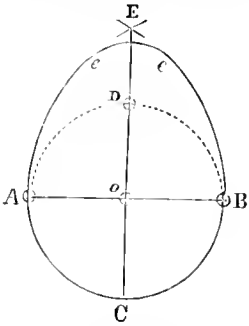

Fig. 10.

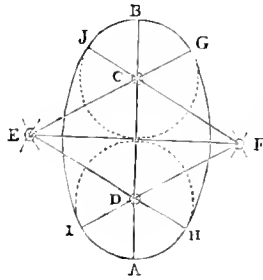

Fig. 11

6. To Describe an Elliptical Figure on any Given Line.—The diameter line A B (fig. 11) is 10 feet in length; divide it into four equal parts. From c and D, with the radius D A, or c B, describe circles touching each other in the centre. From c and D, with radius c D, describe arcs cutting each other in E F. Draw the lines E O, E D, F C, and F D, and produce them until they cut the circles in G, H, I, and J. From E and F, with the radius E G, or F J, draw arcs uniting G H, and I J, which will complete the figure.—M. O'DONNELL, Gardener to E. Leeming, Esq., Spring Grove, Richmond.

PEAS IN 1870.

The writer of the article on "Peas in 1870," which appeared in last week's issue of THE JOURNAL OF HORTICULTURE, is evidently incorrect in describing Carter's First Crop and Sutton's Ringleader as being two distinct sorts of Peas.

At the time of sending out this Pea, in 1864, it was discovered by the two firms who afterwards introduced it to the public, that they both were possessed of an early Pea of undoubted merit, but from the source whence it came, and also from its general appearance and characteristics, there was no doubt that the Pea, whether called Sutton's Ringleader or Carter's First Crop, was one and the same Pea. However, this is an old story now, because the Pea was at the time of sending out, and has been ever since, advertised by both firms as being identical; therefore Mr. Castle must either have been deceived by his seedsman, or have muddled his trials himself, as it is utterly incorrect that Sutton's Ringleader is 3½ feet high, or that it is either earlier or later than Carter's First Crop. It may be as well to remark that all early Peas are liable to degenerate in the quality of earliness, unless they are each year carefully selected; but even this fact will not assist Mr. Castle's statement, because we will challenge anyone to name an early Pea of 3½ feet high, which is earlier or so early as Carter's First Crop or Sutton's Ringleader. If you will permit us we will give you the results of our last year's trial of early Peas at our trial ground, the correctness of which we will vouch for:—

No.	Variety.	Sown.	In Bloom.	Fit to Pick.	Height.
1	Carter's First Crop or Sutton's Ringleader	March 5th	May 12th	June 6th	2 ft. 6 in.
2	Dickson's First and Best	"	" 15th	" 8th	3 ft.
3	Daniel O'Rourke	"	" 19th	" 13th	3 ft.
4	Early Emperor	"	" 22nd	" 16th	4 ft.
5	McLennan's Little Gem	"	" 1st	" 8th	1 ft.
6	American Fom Thumb.	"	" 22nd	" 13th	1 ft. 6 in.
7	Beck's Gem	"	" 22nd	" 16th	1 ft. 6 in.
8	Bishop's Long-podded	"	June 1st	" 19th	2 ft.
9	The Peabody	"	" 6th	" 24th	1 ft. 6 in.
10	Dwarf Waterloo Marrow	"	May 19th	" 19th	1 ft. 6 in.
11	Laxton's Supreme	"	" 29th	" 21st	4 ft.
12	Advancer	"	June 1st	" 19th	3 ft.

If it is of sufficient interest to your readers we could publish a complete list of our Pea trials. [Do; we will find space for them.—Eps.]

We may also remark that Laxton's Prolific Longpod Pea is not deserving of being described as "the worst-flavoured Pea of the season." It is one of the most productive of our Green Marrows, and in flavour is quite equal to any Green Marrow in cultivation.

While on the subject of Peas, we must confess our surprise that none of your numerous readers have had a word to say in favour of Laxton's Alpha. In our opinion it is a Pea without an equal amongst early wrinkled Marrows, both for its earliness and fine flavour.

We can recommend "E. G.'s" trial of Peas, which appeared in the Journal of the 19th ult., to Mr. Castle's notice, as a model of systematic correctness.—JAMES CARTER & Co., High Holborn.

Mr. CASTLE tells us, to grow Peas well the ground should be trenched 3 feet deep; permit me to inform him that all gardeners are aware of the fact, if they could only persuade their employers to give them the necessary labour. Secondly, Mr. Castle never sows Peas until March; he finds they come in as early as those sown in November. That does not agree with my experience. My Peas, sown on the 16th of November, were gathered last season on the 6th of June, Mr. Castle's on the 18th of the same month. Mr. Castle never sows Peas in November; he finds the birds and mice make great havoc among them. Let him procure six pennyworth of phosphorus paste, spread it on bread, use it three times during the winter, and the mice will not trouble him; and for the sparrows, a few strings of red worsted strung along the rows is all that is required.

Mr. Castle tells us that the last dishes were gathered on the 30th of September, but I sent to table a very nice dish this day (October 27th), but it will not be the last. I hope to go on gathering well into November; and this is nothing new, I have gathered Peas repeatedly on Lord Mayor's day.—R. GILBERT, Burgley, Stamford.

CLIMBING FERNS.—No. 2.

ODONTOSORIA.

The plants in this genus are usually associated with Davallia. I, however, entirely conform to the opinions of those authorities who assert their distinctiveness. The species introduced here is a most elegant plant for training along a rafter or pillar, where its light green airy fronds produce an effect equalled by no other Fern. It should be potted in a soil consisting almost wholly of peat and sand, with perhaps a small portion of loam added to it, and should be kept in the temperature of the stove.

O. ACULEATA.—This lovely Fern may be found in many gardens, sometimes under the name of Davallia aculeata, at others under that of Adiantum aculeatum, and yet how seldom are its beauties displayed to advantage! It is a scandent plant, and therefore requires more room than is usually accorded it. The fronds are bi-tri-pinnate, bearing cuneate somewhat lobed pinnae, which are bright light green. The sori are situated at the edges, with a somewhat pitcher-shaped indusium. The rachis is furnished with short slightly recurved spines. I consider this one of the most beautiful Ferns in cultivation. It is a native of Jamaica, and perhaps other places in the West Indies.

SALPICHLENA.

I am only acquainted with one species in this genus, and it stands in the opposite extreme to the plant just noticed. It is a bold-growing Fern; its fronds are bi-pinnate, extending indefinitely, and produce pinnae often 2 feet in length. Salpichlena is nearly allied to Lomaria; it has forked veins, which are all joined by a vein at the margin, and the sori are borne on a transverse vein running parallel with and close to the costa; the indusium is rolled over the sori like a tube. This plant enjoys a high temperature, and should be potted in peat and loam in equal proportions, with plenty of sand.

S. VOLUBLE.—In a situation where a large bold-growing Fern is desirable this will form a striking object. The fronds attain an immense length, and its long, dark green, arching pinnae are very effective, but it can scarcely be recommended for ferneries of limited extent. S. voluble is frequently to be found in Fern collections in a starved state under the name of Blechnum scandens. It is a native of South America.

GLEICHENIA.

This genus I always look upon as the aristocracy of the Fern tribe. The species are extremely elegant, and have a character peculiarly their own. There are two sets of this genus, one having small orbicular segments to the pinnae, and the other larger and broader fronds with linear pinnae, and the habit is less scandent. The latter section is by some authors considered sufficiently distinct to be elevated to generic rank under the

name of *Martensia*. The true *Gleichenias*, as before remarked, have a character peculiarly their own. Their fronds are several times dichotomously divided, extend almost indefinitely, and bear long narrow pinnae with oval or orbicular segments, which have somewhat the appearance of rows of beads. These plants are considered difficult to cultivate, and there is much truth in this opinion. They are somewhat hard to manage—that is to say, for any length of time. They are admirably adapted for cool ferneries; and I am convinced one of the chief causes of failure in the cultivation of *Gleichenias* is an excessive amount of heat. Another fault lies, I think, in confining them in too narrow a compass, for these plants are essentially surface-rooters; they do not want much depth, but they require an extensive surface for their rhizomes and roots to spread over, and if this accommodation is not afforded them the fronds become very weak through overcrowding, and dwindle away to miserable, sickly, sticky-looking objects. To cultivate these plants successfully I adopt shallow pots, and drain them well. The soil in which the *Gleichenias* thrive well with me is brown fibrous peat used somewhat rough. I add a good portion of silver sand, some lumps of sandstone, and a little light loam. They require a liberal supply of water all the year round, but especially during summer, at which season the sun's rays must be kept from them: in fact, I have found them succeed best in a house with a northern aspect.

G. MICROPHYLLA is a fine, free-growing, scandent plant, fit either for public exhibition or home decoration; in the latter case it may be either trained out upon sticks or upon a rafter or pillar. The fronds are several times dichotomously forked; the stems are all clothed with short reddish brown hairs; the ovate segments are dark green on the upper side, the under side paler and quite plain. It is a superb plant, and may sometimes be found in cultivation under the name of *G. circinata*, by which some authorities say it should be known. Native of Tasmania and various parts of New South Wales.

G. DICARPA.—In general habit this resembles the preceding; it has the same scandent fronds and bead-like pinnae. This, however, differs in the orbicular segments having the edges turned over, forming a little pouch or pocket on the under side. Another point of distinction is its perfectly smooth stems and branches, and it is somewhat more compact than *G. microphylla*. It is found in the same habitats as the preceding.

G. HECISTOPHYLLA.—In this species we have a very elegant plant, and perhaps the most slender-growing of all the scandent *Gleichenias* in cultivation. The dichotomous forking of the fronds is the same. The stems are all thickly clothed with reddish hairs; and the somewhat large orbicular segments have their edges rolled over and form a very small pouch on the under side. It is a native of New Zealand.

G. SEMIVESTITA.—An exception must be made in the cultivation of this species, for it really thrives best in the temperature of the stove. Its general appearance is the same as that of all the species in this section. The stems are somewhat densely clothed with reddish brown hairs; the segments inclined to be ovate and quite plain on the under side. Native of New Caledonia.

G. SPELUNCÆ.—This is one of the most beautiful kinds in cultivation. The fronds are forked, and the segments of the pinnae are somewhat larger than those of the species previously described, and not sacculate, bright light green on the upper side, very glaucous underneath. It should be grown in the cool house, and is a native of Tasmania and New South Wales.—
EXPERTO CREDE.

APPLE-GRAFT STOCKS.

THE Burr Knot Apple is described in "The Orchardist" by Mr. Scott, of the Merriott Nurseries, in Somerset, as striking freely from cuttings. The use of the Burr Knot as an Apple stock is very likely, whether under the guise of English Paradise I cannot conjecture, further than Mr. Scott, in his preface to "The Orchardist," says, or suggests it to be so.

I remember a story of an orchard farmer who, happening to push a random cutting of Burr Knot into the ground, and finding it strike wonderfully and fruit precociously, ever afterwards adopted it for Apple stocks, and which stocks he raised by thrusting cuttings of the Burr Knot into whole Potatoes, and planting the Potato and cutting, like a drumstick reversed, together, the Potato to rot, the cutting to grow. Perhaps the succulence of the Potato promoted the growth of the cutting.

The Stibbert Apple, too, is described by Mr. Scott, though not identified with the Dutch Codlin, if the same Apple. I

know not if the Stibbert stock is made use of under the guise also of English Paradise, further than Mr. Scott says as much in the preface of "The Orchardist."

The Nonesuch Apple is not mentioned as one of the English Paradise stocks in the preface already referred to, unless included as a surface-rooting Crab (Apple) stock, though Mr. Scott does not speak of the Nonesuch stock in very flattering words in his late reply in your Journal to my own inquiries.

Perhaps Mr. Scott will tell us if the various stocks used—Burr Knot, Stibbert, Nonesuch, Donein or Crab, and Pommier de Paradis, give any peculiar character to the foliage and hue of the bark of the Apple grafts or scions grown upon such stocks respectively, and how far the fruit of the graft or scion is affected by its foster-parent stock.—READER.

MUSHROOM-GROWING IN PARIS

THE readers of this Journal may have seen, in some of the daily papers, a description of a mode by which Mushrooms are said to be obtained with greater ease than by that usually adopted. This mode has its origin amongst our neighbours the French, and consists of sowing the spores or seeds of the Mushrooms instead of using spawn. This is all the essential difference there is; but some scientific means are necessary to obtain this seed, and the ordinary reader who may have perused the description of the manner in which the operation is performed, will be puzzled by the technical terms used, and in adopting the method in question it is probable he will be disappointed in the result. I certainly do not deny that Mushrooms may be so grown, but as many conditions are necessary for their successful cultivation, the mere fact of one particular method having once succeeded is no proof that it will always do so. Some condition necessary to success may be wanting, and a failure result, but those anxious to try experiments might do so in this case with perfect propriety, and, if successful, by reporting the result they would advance the science of horticulture.

The mode seems pretty well explained. A substance favourable to the growth of the Mushroom is prepared, and on this the seed (as I may be allowed to call it) is sown, and in process of time a crop is produced. This is the plain homely feature of the case, and if some one produce a specimen of Mushrooms so grown at one of the winter meetings of the Royal Horticultural Society, more light will be thrown on the matter. The Mushroom, in common with other Fungi, produces myriads of the most minute objects, which, whether we designate them as seeds or by any other name, evidently serve the purpose of reproduction, and they are in such abundance that they exist almost everywhere, but only grow in favourable situations. In the growth of Mushrooms by the mode described, I should say the conditions necessary to insure success must be correct to the greatest nicety, otherwise failure must occur. This often happens in the old-fashioned method of growing Mushrooms from spawn; and how uncertain, then, must be the result in the new one with such minute things as the seeds, to discern which a microscope is required.

In making the above remarks on the French mode of growing Mushrooms, I by no means intend throwing any discredit on the plan, or to damp the ardour of those intending to try it; on the contrary, I shall be glad to hear of its being extensively tried and the results reported. The fructification of most of our Fungi is but imperfectly known except to the learned few, and this class are not always expert cultivators, but we must listen to what they may reveal, and act accordingly. With such very minute objects as the seeds referred to, it is, I fear, hopeless to attempt much beyond carrying out an experiment or two. We must, therefore, wait and learn what nature can do for us, and in general she performs what would baffle the skill of our most expert nursery propagators. We see Ferns and Lycopods springing up in hothouses and other places favourable to their growth with such rapidity that every place is speedily covered with them, and when we become better acquainted with the requirements of the Mushroom, it is likely it may be obtained in as great an abundance.

Taking, therefore, for granted that what may be called the seeds of the Mushroom (not the spawn) are produced in such infinite numbers as to be everywhere at the season most suitable to the growth of Mushrooms, we may fairly expect these to be produced when all the necessary conditions are complied with. It is, therefore, not unlikely that in the caves at Paris, where Mushrooms are grown in greater abundance than per-

haps anywhere else, the conditions necessary to success are much more perfect than in most other places; and Mushrooms having been grown there so long, it is not unlikely the very atmosphere may be so charged with the minute bodies which serve to propagate this fungus, that Mushrooms may spring from them in course of time in the same way as Ferns and Lycopods are produced, when in a suitable position, without other aid from us than supplying the shade and moisture which are necessary to their growth. I am, therefore, not altogether a disbeliever in the possibility of Mushrooms being produced by seed as described in the daily papers, but I more than doubt the cultivator's having the means of sowing such seeds over his beds when prepared, and I would advise inexperienced readers to consult their seed catalogues carefully before they send for a packet of Mushroom seed, unless to confer a favour on some acquaintance the day after the 31st of March. It is not at all unlikely that the humorous Frenchman may have sown his beds with something that might resemble seeds in the presence of some special correspondent, and that Mushrooms followed; but I strongly suspect sand, dust, or something of the kind, formed the seeds seen by the gentleman of letters, ordinary spawn having been used before. It is not at all unlikely that the spawn in one bed may have run along the floor and reached the other, and thus produced a crop, or the very air may be so loaded with all the requirements necessary to this end that only subjects to work upon may be wanted, and fresh dung furnishing this, success is the result. At the same time it is most likely that when tourists, visitors, and specials were not in the caves, pieces of spawn were inserted in the beds and that these did the work and not the mysterious Mushroom seeds. More need hardly be said on the matter, than that the caves spoken of must be well adapted to the purpose, and great credit is due to those who there cultivate the Mushroom so successfully.—J. ROBINSON.

Since the above was written what a sad change has come over the fair and beautiful city of Paris! Its gardens, parks, squares, and even cemeteries, are converted into so many enclosures for cattle, or torn up for still ruder purposes, while the Mushroom caves may be turned to purposes widely different from that to which they were put when the above was penned. All must mourn that such a change should take place. At some future time I may return to the subject of growing Mushrooms in caves, for it is not without its parallel in this country, as very many years ago excellent specimens of Mushrooms were produced in a coal mine where horses were kept, and Mushroom beds in chalk caves are not uncommon.—J. R.

AUTUMN PLANTING OF POTATOES.

The experiment was tried upon the farm of Mr. William Lawson, at Bleunerhasset, Cumberland. The sets were Regents, chiefly whole, and varying from 3¼ to 1¼ oz. in weight, 1¼ being the average, and were planted about 9 inches apart. They were sorted from one field's produce, and of a uniform size, to ensure equality of conditions. The plots, of three drills each, were first before planting sown with a mixture consisting of superphosphate (mineral), 5 cwt.; marlate of potash, 2½ cwt.; and sulphate of ammonia, 1¼ cwt. per acre. The March plot was first to turn yellow, then February, April, and all except May came next, May being the last. All were raised, sorted, and weighed October 6th, with the following results:—

AUTUMN versus SPRING PLANTING.

Date when planted.	Weather at time of planting.	Weight per Acre.	Value per cwt. as raised.	Value per Acre.
1869.		tons. cwt.	Shillings.	£ s. d.
October 6	Mild and dry.	3 11	2 31	8 4 1
November 5	Cold winds and heavy showers.	5 14	2 30	11 13 5
December 15	Cold and slight rains.	5 3½	2 55	13 17 9
1870.				
January 12	Cold and damp.	6 6½	2 54	16 0 7
February 7	Frost and slight snow.	9 5	2 46	22 15 8
March 7	Dry frost.	9 10½	2 49	22 15 7
April 8	Warm.	8 8	2 49	29 3 2
May 9	Warm.	9 14	2 42	21 18 9

In January plot, the misses were very numerous; April sets were much sprouted when planted; in May the seed left was insufficient, and this plot was planted with a mixed lot, containing Rocks; it cannot, therefore, be fairly compared with the others. The column "Value per cwt. as raised" is calculated from the weights of large, medium, and small, when hand-

picked; the large being valued at 4½d. per stone, the medium at 3d., and small or pig Potatoes at 2d. They are such as would be sorted by 1¼ and 1½ inch riddles. Excluding October and November, and also M.v. because of its mixed seed, it will be seen that the best quality—i.e., the highest value per hundred-weight, was produced by the seed longest in the land. Thus February, though 5 cwt. less per acre in weight than March, is of almost equal money value per acre, because of its greater proportion of large Potatoes, and, consequently, higher value per hundredweight. As far as this one experiment goes, it shows:—1st, That for weight early in March is the best time to plant. 2nd, That for profit February is equally as good as March.—(Mark Lane Express.)

LILIUM AURATUM AND OTHER BULBOUS PLANTS.

I HAVE read with much interest Mr. Douglas's note on the cultivation of *Lilium auratum*. Will he tell us, in addition, why he considers it best to shake the soil entirely from the roots in preference to scratching away the loose soil? I should be very sorry to treat mine in the way he recommends. In 1869 mine threw up one stem and produced fourteen blooms; this year it threw up two stems, which produced seventy-six blooms.

If Mr. Douglas dries-off his *Hyacinths*, *Tulips*, and other bulbs, I would advise him another summer to water them if necessary as long as there remains a leaf, and report the results.—EXPERTO CREDE.

[In the article on *Lilium auratum* referred to, allusion was made more particularly to pots containing a number of bulbs. I said, "As many as a dozen bulbs are planted in a 13 inch pot." As the result of my cultivation is given, "EXPERTO CREDE" will observe that three bulbs in 1869 produced fourteen spikes. In 1870 all, or at least all except two pots of bulbs, were repotted about the middle of October, and on shaking out the bulbs from the pot alluded to above there were fourteen fine bulbs, the produce of last year's three bulbs. These were separated carefully and repotted in a 15-inch pot. As there is no room for them in the frames this year, I have plunged about two dozen pots of them in cocoa-nut fibre refuse out of doors. They had a good drenching of rain before they were plunged, and more since, which will do them no harm. By-and-by, if severe frosts set in, something will be placed over them to throw off the water. They will be plunged in the frame in January. If fourteen good bulbs were obtained from three in one season, surely the system of cultivation must be good, especially as they throw up good strong spikes which flower well. Several of the spikes were 10 feet in height.

I have frequently done as "EXPERTO CREDE" seems to have done with his one bulb in a pot—that is, only scratched away a little of the earth and repotted in a larger-sized pot. Thus treated the bulbs have done well, but when three or four spikes are thrown up from one bulb, I separate the bulbs and they also do well; you can then have three or four pots, or you can plant all in one pot.

One thing must be borne in mind—do not disturb *Liliums* after they have started into growth; they do so very soon after the spikes die down. I had some *Lilium lancifolium album* bulbs which, although standing out of doors all the season except the few weeks when they were in flower, had started into growth by the middle of October, when the others were potted; and, further, if you want your work well done, do it carefully, do it at the right time, and do it yourself. The right time to pot *Liliums* is when the leaves turn yellow on the stems.—J. DOUGLAS.]

BOX EDGING.

Your correspondent, Mr. O'Donnell, says (page 301), "As soon as all the Box is planted, the whole should be clipped to an equal height, and flat at the top." I presume he must mean the time of planting to be the month of April, which would be carrying on improvements to a very late period, if the young gardener wish to keep himself equal to all the demands of an establishment. Surely he could plant at the end of September or October, but between this time and April I think cutting Box very dangerous. Should there be a severe winter the major part of it would be killed, and to replace it after the work is finished in small designs is a job better dreamt of than performed.

As to cutting Box flat, that is entirely a matter of taste, but

to me it is very unsightly, cramped, and too formal, with the great disadvantage of harbouring myriads of insects. In some small chain patterns I have seen clumps of Box cut flat, and in different shapes, but when these are compared with the free lightness of the plants in the beds they are anything but in harmony with the latter, however well they may look when the beds are empty: therefore I think they are at all times to be avoided. I think that all edgings should be as light as possible, and Box is certainly one of the lightest if cut in the shape of an inverted V at 2 inches in height, but if it is cut square, 4 inches by 4, as it often is, it looks very heavy indeed.—J. T.

ROYAL HORTICULTURAL SOCIETY.

NOVEMBER 2ND.

FOR this dull time of year the Council-room looked unusually gay; Orchids were represented by some splendid specimens from Lord Lonsborough's and Messrs. Veitch's: Chrysanthemums, though the meeting was early for them, formed a most effective mass, while of fruits there was an excellent display. The attendance of visitors was large, and it is to be regretted that many of them availed themselves of the time when others were seated at the General Meeting to move about the room, to the great inconvenience of those who were bent on hearing.

FRUIT COMMITTEE.—G. F. Wilson, Esq., F.R.S., in the chair. A prize of £5 was offered by Messrs. J. & C. Lee, of Hammersmith, for the best three bunches of Madresfield Court Grape. Three very fine bunches were exhibited by Mr. Zadok Stevens, of Trentham, and three by Mr. Adams, of Bank Hall, Barnley. Those of Mr. Stevens, being infinitely the best, received the prize. The berries were very large and deliciously flavoured. Mr. J. Tomkin, gardener to S. T. Kekewich, Esq., Peamore, sent a large bunch of a Grape to be named, which proved to be Alicante. Mr. W. Ellis, gardener to R. Lewis, Esq., Greenford Hall, Middlesex, sent three bunches of Black Prince Grapes, from Vines that had been severely infested with mildew. They were cut back and lifted, and these were part of the produce of sixty bunches from two rods. Mr. Wells, of Southend, sent eight bunches of Black Hamburg, grown in the ground vineries, which were of such superior quality as to obtain a special certificate. He also exhibited bunches of the Sultan Grape without seeds. A shoot of a Hungarian Grape, introduced by Rev. M. J. Berkeley, and grown at Chiswick, was exhibited to show the very brilliant hues of dying foliage. It is the richest-coloured of all the varieties. Mr. Challis, The Gardens, Wilton House, sent a Pine introduced from India, which had somewhat of the character of the Blood and Otaheite, but the flavour was not remarkable. Messrs. J. & C. Lee sent fruit of the Autumn Surprise White Raspberry. Mr. Lamb, gardener to G. T. Davy, Esq., Colston Bassett, Bingham, sent a Melon, weighing about 3 ozs., called Colston Bassett. It is a handsome-looking fruit, lemon-coloured, and finely and evenly netted, but the season was too late to form a correct judgment of its merits.

Mr. Charles Turner, of Slough, sent dishes of handsome fruit of Cox's Orange Pippin. Mr. Small, of Colnbrook, sent a seedling Apple, called Queen Victoria, too much like Golden Noble. Mr. Jennings, of Shipston-on-Stour, sent fruit of his new Apple, The Fairy, figured in "The Florist," of March last; the season being early the flavour was as yet acid. Mr. Alexander Dean, Old Shirley, Southampton, sent an Apple, presumed to be a seedling from Blenheim Pippin, called Beauty of Haunts. It was the same as Blenheim in texture and flavour, but the colour was higher than that of the Blenheim usually is, some specimens being quite red on one side. The Committee considered it the same as Blenheim. P. Northall Laurie, Esq., of Paxhall Park, Hayward's Heath, sent six dishes of Apples grown on cordon trees, consisting of Reinette de France, Reinette du Canada, Calville Blanche, Golden Winter Pearmain (called Reine des Reinettes), and Reinette d'Angleterre (King of the Pippins). The Calville Blanche and Reinette du Canada were unusually fine, and received a special certificate. Mr. McKenzie, Alexandra Park, also sent eight dishes of Apples which had been grown on cordons, which received a special certificate. Mr. Gardiner, gardener, of Eastington Park, Stratford-on-Avon, sent thirty-nine varieties of Apples, which received a special certificate. Mr. Davie, Broad Bridge Street, Peterborough, sent two seedling Apples, one of which was recognised as Rymer. G. F. Wilson, Esq., Weybridge Heath, sent a dish of very handsome Beurré d'Anjou Pears.

Messrs. Veitch & Sons sent specimens of their Giant Autumn Cauliflower, a fine, large, late Cauliflower. The seed was sown on the 16th April, the same day as Walksheren, Asiatic, and Early Erfurt. This is now coming into use, while all the other sorts are quite past. Mr. Lamb, gardener to G. T. Davy, Esq., Colston Bassett, sent tubers of a Potato from Guatemala. Mr. C. Hales, Manor House, Bassingbourne, sent a large kidney Potato, which when cooked was mealy and of good flavour. Mr. Gunn, The Furze, Lee, Kent, sent some very large Tomatoes, which were coarse and considered objectionable. Mr. Gilbert, The Gardens, Buryholy, sent a seedling Cucumber called Knight of St. Patrick, raised between Telegraph and Wonderful.

Mr. B. Saunders, of St. Helier's, Jersey, sent a collection of twelve dishes of Apples and twelve of Pears, all of which were remarkably

well grown, and received a special certificate. Messrs. Carter & Co., of Holborn, sent a collection of twelve varieties of Celery, and examples of Red Flourball Potato, a very large red-skinned variety. Mr. Lidgard, of Hammersmith, sent specimens of Williams's New White Matchless Celery.

Prizes were offered for the best six dishes of dessert Pears, and brought from fifteen competitors many dishes of fine fruit. The first prize was awarded to Mr. Stephenson, gardener to F. C. Barker, Esq., Leigh Hall, Essex, who had Duchesse d'Angoulême, very large and fine; Beurré Diel, Marie Louise, Knight's Monarch, Glou Morycan, and Passe Calmar. Mr. Miles, gardener to Lord Carrington, Wycombe Abbey, was second, with very fine fruit of Beurré Diel, Huysse's Victoria, Beurré Bose, Van Mons Léon le Clerc, Marie Louise, and Beurré Clairgean. The third prize went to Mr. S. Ford, gardener to W. G. Hubbard, Esq., Horsham, for Forelle or Tront Pear, very fine; Duchesse d'Angoulême, Triomphe de Jodoigne, Nouveau Poiteau, Beurré Diel, and Thompson's.

Prizes were likewise offered for the best collection of Potatoes, and there were only two competitors. The first prize was adjudged to Mr. Frisby, gardener to H. Chaplin, Esq., Blankley Hall, Sleaford, who had tubers of very large size, several of them, however, being very coarse kinds. Among the varieties were American Peach Blow, Pink-eyed Regent, Ashleaf, Myatt's Prolific Ashleaf, Rivers's Royal Ashleaf, and Lapstone. The second prize went to Mr. S. Ford, who had generally clean, and for the most part rather small tubers.

FLORAL COMMITTEE.—W. Beattie Booth, Esq., in the chair. Mr. Denning, gardener to Lord Lonsborough, Grimston Park, Tadcaster, sent a splendid collection of Orchids, most conspicuous among which was a magnificent specimen of *Vanda carnlea*, with four spikes, each with from thirteen to fifteen flowers; *Cattleya Harrisoni* and *Oncidium aurosum* were also remarkably fine. Among the others were the beautiful *Pleione Wallichii* and *lagenaria*, *Phalenopsis Lowii*, *Vanda lutescens*, *Cattleya maxima*, very fine, the brilliant scarlet *Sophranitis grandiflora*, *Odontoglossums*, *Oncidium*, *Miltonia Morelliana*, the large-flowered white and orange *Dendrobium formosum*, &c. Mr. E. Culley, gardener to E. Salt, Esq., sent a pale variety of *Odontoglossum Alexandræ*, with a very fine spike.

Messrs. Veitch contributed a collection, in which were a fine specimen of *Cattleya labiata*, *Miltonia Warszewiczii*, an excellent example of *Zygopetalum maxillare*, *Apelandra aurantiaca* Roezlii, of which the orange scarlet flowers are very showy, *Urecolina aurea* with pendulous yellow bells, *Adiantum Veitchii*, *Dracena porphyrophylla*, a noble looking plant, and several *Cattleyas*, the most remarkable of which was *C. Dominian lutea*.

Mr. Bull, gardener to J. Montgomery, Esq., Pole Hill Lodge, Hillingdon, sent a nice collection of *Cyclamens*; and Mr. C. Edmonds, Hayes Nursery, sent a similar but larger collection in excellent bloom, likewise several seedling *Tricolor Pelargoniums*. Mr. R. Clarke, market gardener, Twickenham, also had a large collection of *Cyclamens*.

From Mr. Bull, of Chelsea, came a group of Palms, Cycads, Orchids, and other plants. Of the first named *Licuala horrida*, a pleasing light green sort, received a first-class certificate; and among the others were *Welfia regia*, *Zalacca Wagneri*, *Astrocaryum mexicanum*, *Areca Verschaffeltii*, *Damocorops melanochates*, and *Cocos Romanzoffiana*. A very handsome species of *Enecephalartos*, which Mr. Bull has before exhibited, also formed part of the collection. *Curculigo recurvata striata*, with handsome white-striped leaves, received a first-class certificate. The Orchids consisted chiefly of *Odontoglossum grande*, *Vanda carnlea*, *Pleione lagenaria*, *Burlingtonia venusta*, and *Oncidium Papilio* and *crispum*.

Mr. Parker, Exotic Nursery, Tooting, sent *Ixora amabilis*, which has before received a certificate. *Begonia Craigii*, with dark bronzed foliage and of strong growth, a handsome plant for mixing with others with lighter-coloured foliage, came from Major Trevor Clarke; and *Begonia geranioides*, with pure white flowers, and leaves not unlike those of a Geranium, of dwarf growth and very free-flowering, was exhibited by Messrs. Backhouse, of York. Messrs. Perkins & Sons, Park Nursery, Coventry, sent *Gazania splendens arceo-variegata*, the leaves irregularly edged with yellow, but rough in appearance.

Mr. Morris, Kent Waterworks, Deptford, showed a basketful of seedling *Tricolor Pelargoniums*, and specimen plants of Lucy Grieve and Mabel Morris. King of Trumps, with large trusses of bright orange scarlet flowers, was sent by Mr. Eckford. From Messrs. A. Henderson & Co. came *Ficus vesca variegata*, the leaves variously marked with greenish white, the variegation sometimes covering nearly one-half of the leaf. Messrs. E. G. Henderson & Son sent a large group of *Tricolor Pelargoniums*; *Bouvardia elegans*, stated to be an improvement on *Bouvardia Hogarth*; *Mohria thurifraga achilleefolia*, a very elegant crisp Fern, which had a first-class certificate; and a fine collection of winter-flowering tree Carnations, of which Vulcan, red, received a first class certificate. From the same firm came also several seedling Japanese Chrysanthemums. First-class certificates were awarded for Bismark, very showy, orange, and Erectum superbum, fine violet rose. Mr. Bull likewise sent several varieties, of which Jane Salter received a first-class certificate; it is a white tinged with purplish lilac, 7 inches in diameter, and is a highly decorative variety. Garnet, rich blood red, was very fine in colour, though comparatively small. Renown, large-flowered, with broad incurved florists, yellow tinged with brown on the back, received a similar award. Mr. William

Paul exhibited cut blooms of seedling hedding Geraniums, many of them new in colour and very beautiful.

A first-class certificate was given to Messrs. Cathash, of Highgate, for *Acubia japonica* f. *aureo-maculata* with the leaves much more extensively variegated with yellow than the common kind. From the Society's garden at Chiswick was sent a plant of *Dahlia imperialis* about 9 feet high, and bearing a few flowers and a profusion of buds. Mrs. McIntosh, 25, Norfolk Terrace, Bayswater, sent a case of beautifully skeletonised leaves by a process which is stated to be very simple, and to occupy only an hour. For this a commendation was given.

First-class certificates were given to Mr. Bull for *Zalacca Wagneri*, *Corcaligo recurvata striata*, *Licuala horrida*, and Japanese *Chrysanthemums* *Jane Salter* and *Renou*; to Messrs. E. G. Henderson for *Mobria tharifragu achilleæfolia*, winter-flowering tree *Carnation Vulcan*, and for Japanese *Chrysanthemums* *Bismark* and *Erectum superbum*; to Messrs. Veitch for *Dracena porphyrophylla* and *Cattleya Dominiana lutea*, and to Messrs. Cathash for *Acubia japonica* f. *aureo-maculata*.

A second-class certificate was awarded to Mr. Eckford for *Zonal Pelargonium King of Tramps*.

Special certificates were given to Messrs. Veitch for the group of plants, and for *Zygotelum maxillare*; to Mr. Denning for his collection, also for *Cattleya maxima*, *Cattleya Harrisoni*, *Phalaenopsis Lowii*, and *Vanda cœrulea*; to Mr. Bull for his collection; to Mr. H. Clarke, Mr. Edmonds, and Mr. Bull, of Hillingdon, for collections of *Cyclamens*; to Messrs. E. G. Henderson for a group of tree *Carnations*, and to Mr. Morris for *Tricolor Pelargoniums*.

Prizes were offered on this occasion for specimen plants and cut blooms of *Carnations*, also for berried plants.

Class 1 was for the best six large-flowered *Chrysanthemums*. The first prize was taken by Mr. Rowe, gardener to Mrs. Lewis, Rotherhampton, with remarkably fine specimens, in full bloom, of *Lady Harding*, *Prince of Wales*, *Maréchal Ducroc*, *Dr Sharpe*, *splendid*, *Mrs. George*, and *Lady Talfourd*. The second prize went to Mr. James, gardener to W. F. Watson, Esq., Isleworth, who had *Mrs. George Rundle* in good bloom, *Prince Alfred*, with *Queen of England*, *Golden Queen*, and others not fully out. Mr. Forsyth, of Stoke Newington, was third with specimens of excellent growth, and which will be very fine a week or two hence.

Class 2 was for six *Pompons*. Mr. Rowe was again first with, among others, very fine plants of *White* and *Golden Cedo Nulli*, and several *Anemone*-flowered kinds. The second prize went to Mr. James, gardener to W. F. Watson, Esq., whose plants, though well grown, were not in full bloom.

Class 3 was for twenty-four cut blooms. In this Mr. Rowe took the first prize with an excellent collection, in which were very fine examples of *Empress of India*, *Rev. J. Dix*, *Princess of Wales*, *White Globe*, *Prince Alfred*, *Novelty*, *Queen of England*, *Venus*, *Jardin des Plantes*, *Lady Slade*, and *Lady Talfourd*. Mr. Forsyth came second with a stand in which were fine blooms of several of the above.

Class 4 was for the best twelve. In this Mr. Rowe was again first, and Mr. Berry was second, Mr. James being third.

Mr. Forsyth exhibited excellent stands of *Anemone Pompons* and Japanese varieties.

Only one collection of berried plants in pots was exhibited, and it was far from equal to what might have been expected. It consisted of *Ardisia crenulata*, *Solanums*, *Capsicums*, and a *Berberis*. This came from Mr. George, gardener to Miss Nicholson, Patney Heath, and received a first prize.

GENERAL MEETING.—S. Rucker, Esq., F.L.S., in the chair. After the usual preliminary business had been gone through, in the absence of the Rev. M. J. Berkeley, who had been called away through the sudden illness of a relative, Major K. Trevor Clarke made a few remarks on the plants shown. There was, however, he said, a dearth of objects of scientific interest such as usually formed the subjects of comment at these meetings. He then pointed out one of the autumn *Crocuses*, *Crocus longiflorus*, as being not only very uncommon, but very pretty. In the pomological department he would direct especial attention to the *Fairy Apple*, which had sprung from the seed of the scarlet *Siberian Crab*, mentioned in our Fruit Committee report, and remarked that an enormous improvement is at once effected when wild species are fertilised with pollen of cultivated garden kinds.

Mr. Marshall directed attention to the *Tree Carnations* as most useful plants for conservatory decoration in winter, on account of their continuous blooming; also, to Mr. Bull's patent cases for the transmission of plants across the tropics. These have spars of wood across the glass like Venetian blinds, which prevent the sun parboiling the contents of the case, and are also provided with ventilation at the top. To illustrate the effects of the ordinary plant cases on *Orchids*, Mr. Bull sent a large basketful utterly destroyed in transit. Messrs. E. G. Henderson likewise sent a case, the principal feature of which is, that the drip from the front of the glass runs into a zinc spout, and is conveyed into a perforated tube surrounded with charcoal at the bottom of the case, whence the moisture passes through the soil or packing before again entering the atmosphere of the case. The front is padded on, then fastened with screws. This case, which we believe has been found to answer well, is a lean-to form, Mr. Bull's, as shown, being a span-roof.

The Chairman, in announcing that the next meeting would be held

on December 7th, said that Mr. Bateman had offered a £5 prize for *Cattleyas*, further particulars respecting which would shortly be published.

HOW TO OBTAIN ROSES ON THEIR OWN ROOTS.

I HAVE read in a contemporary article under the heading of "Roses for Hedges." This is a good idea—one I, as an old Rose cultivator, have long believed in and practised. The month of November, into which we are just entering, is a busy time for me as a grower of Roses, as during that month I put in my cuttings, and plant Briar and Manetti stocks for budding. With regard to cuttings, it is of the greatest importance to get them all planted before severe frosts set in, and the ground gets too cold. Although both the Dog Rose and Manetti are hardy, they are apt to suffer from the effect of frost if exposed to it after they are taken up, and weak shoots, instead of strong healthy growth, result.

In any place where there is a great demand for cut Roses, every exertion should be made to keep up a sufficient supply. I always make it a rule here to supply the table with cut Roses during eight months out of the twelve: in March and April I get blooms from plants forced in pots; in May from walls; and from that time till the autumn has begun to strip the trees of their emerald tresses, the blooms come from various sources—some from plants budded on the Briar, some on the Manetti stock, and others from plants on their own roots. To obtain a good supply of Roses, three classes are principally grown—namely, *Noisettes*, which are mostly grown on walls, and protected with branches of evergreens during winter; *Tea Roses*, which are grown and protected the same way as the *Noisettes*—both of which I find to bloom earlier and finer from the protection they get, as the blooming wood is preserved intact, instead of being killed back, as is frequently the case; and the *Perpetuals*, which form the largest class grown here. A great many of these are on their own roots, and these I obtain in a very simple manner. I first trench a piece of ground in the kitchen garden, two spits deep, and mix plenty of rotten dung with the soil as the work proceeds. The cuttings I prepare in the following manner: I select the strongest growers of the *Perpetual* class, and cut up the wood into lengths of about 6 inches, and take out all the eyes but the three top ones. The ground should be trodden firm at planting time, and I always select for this a day dry enough to prevent the soil sticking to one's feet. A line is put across the ground, and the soil chopped away from the line by the spade just deep enough to take the cuttings, leaving the eyes out of the ground; they are placed from 4 to 6 inches apart, and the soil trodden firmly about them. And so I plant a piece of ground, leaving a space between the rows of fully 2 feet. I find the cuttings strike more readily in a sandy soil, and generally place some road-grit about them previously to treading the earth firmly against them. Here the cuttings remain for two years. At the end of the first year the growth of that season is cut back to about four or six buds from the ground, and by the end of the second year they form fine healthy plants.

These I use for the formation of *Rose hedges*, the front row of a *Rose border*, for potting, for forcing purposes, or to form a bed of *Roses* on their own roots. The ten varieties of *Perpetuals* now to be named are very fine plants from cuttings struck this way three years ago, and they are all strong growers and constant bloomers—viz., *Général Jacqueminot*, *John Hopper*, *Jules Margottin*, *Anna Alexieff*, *Duchesse d'Orléans*, *Auguste Mie*, *Anna des Diebach*, *Charles Lefebvre*, *Mademoiselle Louise Carique*, and *Madame Alfred de Rougemont*.

There are two hardy *Tea-scented* *Roses* growing with the above that stood the severe frost of last winter without any protection—namely, *Gloire de Dijon* and *L'Enfant Trouvé*, a beautiful yellow-flowering kind.

If I were to form a *Rose hedge* of one particular flower, it would be *Jules Margottin*, an old but very free-blooming *Rose*, that is a great favourite with me, and, I doubt not, many more.

—WILLIAM PLESTER, *Elsenham Hall Gardens*.—(*The Gardener*.)

LARGE PRODUCE FROM ONE POTATO.

HAVING obtained a fine *Bovina* *Potato* (weight 1 lb), I cut about two-thirds of it into fourteen sets, and planted them on the 23rd of March. As the rest of the *Potato* showed no eyes, I exposed it to a good bottom heat; by the 2nd of April it had

sent out five vigorous shoots. I then cut it into as many sets, and planted them, having previously manured the ground well, and covered it with an inch of sand. I took up the crop October 20 h, when I had a yield of 133 lbs; thirteen roots weighed together 11½ lbs., one of these weighed 13 lbs.; eleven Potatoes weighed 27 lbs., including one 4 lbs. weight. These Potatoes are most excellent for table use.—R. L. BRADSHAW, *Appleton Academy, near Warrington.*

PORTRAIT OF MR. RIVERS.

THE following extracts from letters enclosing subscriptions, will convey some idea of the motives which influence the contributors to the memorial:—

"I do not know Mr. Rivers personally, but I look on him as a great public benefactor."

"Rivers has given the world his brains, and well deserves recognition."

"I am glad to have this opportunity of showing my respect for one who has contributed more to my enjoyment of life, during the past ten years that I have been an invalid, than any other man living."

The following is the list of the subscriptions already received, towards carrying out the above object:—

	£	s.	d.
JOURNAL OF HORTICULTURE, Proprietors of	5	0	0
Allsopp, H., Esq., Hindlip Hall, Worcester	5	5	0
Barnard, Wm., Esq., Sawbridgeworth	1	1	0
Blackmore, R. D., Esq., Teddington	1	1	0
Bottomer, Fredk., Markree Castle, Collooney	0	10	0
Darwin, C., Esq., F.R.S., Down, Beckenham	2	2	0
Dombrain, Rev. H. H., Westwell Vicarage, Kent	0	10	6
Fitzgerald, Mrs., Shalstone, Buckingham	1	1	0
Harrison, John, Rose Nursery, Darlington	0	10	6
Hole, Rev. S. Reynolds, Caunton Manor	5	0	0
Hooker, Dr. J. Dalton, C.B., Kew	2	2	0
Hopkyns, D. D., Esq., Weyebife, Guildford	5	0	0
Kingsley, Rev. W., South Kilvington	2	2	0
Masters, Dr., F.R.S., Ealing	1	1	0
Moore, Thomas, Esq., F.L.S., Chelsea	1	1	0
Moffat, Mr. A., The Gardens, Hindlip Hall	0	10	6
Morris, Mr. John, Wethersfield	1	1	0
Newington, Dr., Tichhurst	3	3	0
Paul, Mr. William, Waltham Cross	1	1	0
Peach, Rev. C. P., Appleton-le-Street	2	2	0
Pearson, Mr. John, Chilwell	1	1	0
Rudelyffe, Rev. W. F., Okeford Fitzpaine	5	0	0
Rendle, Mr. W. E., Welbeck Street	1	1	0
Rodeu, Dr., Kidderminster	2	2	0
Sparkes, George, Esq., Bromley	3	3	0
Speed, Mr. Thos., Chatsworth Gardens	1	1	0
Taylor, Mr. T. (Webber & Co.), Covent Garden	1	1	0
Turner, Mr. C., Slough	0	10	6
Warner, Mr. J. H., The Abbey, Leicester	1	1	0
Wilson, Edward, Esq., Hayes, Bromley	2	2	0
Wilson, G. F., Esq., F.R.S., Heatherbank	2	2	0

Subscriptions addressed to Dr. Hogg, 99, St. George's Road, London, S.W., will be promptly acknowledged.

SUBSOIL TEMPERATURES.

THE following is an extract from the report of the Under-ground Temperature Committee of the British Association.

At depths of 2 or 3 feet it is necessary to observe, once a week, or so, throughout a year, in order to get the mean temperature at that depth for that year; and this may differ by a considerable amount from the mean of a series of years.

In the report of the Scottish Meteorological Society for the quarter ending December, 1862, there is a comparison of the mean temperature of the air with that of the soil at the depths of 3, 12, and 22 inches, at four stations, from observations extending over five years; and in the "Journal" of the same Society for the quarter ending December, 1865, there is a comparison of the temperature of drained and undrained land from one year's observations, undertaken for this purpose at two stations, and including also a comparison with the temperature of the year. The mean temperature of the air for each day is, in these comparisons, assumed to be the simple arithmetical mean of the maximum and minimum, as indicated by self-registering thermometers 4 feet from the ground. From these observa-

tions, it appears that the mean annual temperature of the soil was in every case rather above that of the air, and that the excess was greater for sand than for undrained clay, and was greater for drained land than for the same land undrained.

The greatest excess occurred in the case of the 22 inch thermometer at Nookten (Valle of Leven), where both surface and subsoil are sandy and dry. The five yearly means at this station were:—

Air 46°.1; soil at 3 inches 46°.3, at 12 inches 47°.3, at 22 inches 48°.0; giving an excess of 1° 9 for the temperature at the depth of 22 inches as compared with air.

The smallest excess, in the case of the 22 inch thermometers, observed for five years, was at Linton (East Lothian) where it amounted to 0°.7; but the observations on the effect of drainage gave for the year of observation an excess of only 0°.2 at the depth of 30 inches in light sandy but undrained soil under a Ryegrass crop, at Otter House near Loch Fyne, the corresponding excess for drained land of the same kind and in the immediate vicinity being 0°.9.

The mean temperature at the depth of 3 feet at Professor Forbes' three stations at Edinburgh, from five years' observations, gave an excess of 0°.55 above the mean temperature of the air at Edinburgh as determined by Mr. Adie's observations.

Observations on soil temperature in England are much needed, but the Greenwich observations give an excess of soil above air temperature falling within the limits above quoted, the excess at 3 French feet being 1°.7, while at 24 French feet it is reduced to 1°. The soil of which the Observatory Hill is composed, and in which the thermometers are sunk, is dry gravel, and the unusual circumstance of decrease of temperature downward observed in the comparison of the 3-feet and 24-feet thermometers, seems to indicate that the surface of the hill is warmer than the surrounding land.

LABELS FOR FRUIT TREES.

"A. R." in last week's issue recommends zinc, and states that "if the label be suspended by copper or lead wire it will last for generations;" "that a glance will show whether the wire is cutting into the tree or not, and that a minute or two will rectify the matter." I once indulged the same delusive fancy, and suffer from it now. First I used lead wire—chemical action, I believe, takes place, besides the harder edge of the zinc cutting the softer lead wire—and about twelve months saw all my labels on the ground; next I used annealed copper wire on about a thousand trees. I am now busy cutting these labels off, for wire seems to have a prescriptive right to cut into the bark and fasten itself in every possible way without the least provocation, causing no end of gum and canker, and if by any remote chance, these do not occur, the label is the sport of winds and the ruin of the bark. I now use a strip of flat lead, stamped with the number which corresponds to the particular tree in my orchard book. This may be liable, besides the trouble, to as many evils as the methods I have already abandoned, but as yet I am innocent.

"A. R." well depicts the promiscuous misnaming of fruit trees. Nothing is more common than to find trees, and some of the commonest, wrongly named; and the lack of knowledge of varieties, and, in fact, of fruit-culture generally, is remarkable in many gardeners who excel in floriculture. As to correctly naming trees, the "greater nurserymen" are by no means immaculate. I have received many trees, from one of the best in every way, wrong to name; but when one has experienced the difficulty of keeping a few hundreds right in one's own garden, and then considers the thousands of each sort a nurseryman is expected to produce, the marvel is that they are so often correct.—C. C. E.

ARE GUELDRIS ROSE BERRIES POISONOUS?

WE ask this question because of the evidence given at an inquest held at Sudbury, Suffolk, on the 27th ult., on the body of the child of the Superintendent of the Cemetery, whose death was supposed to have been occasioned by eating the berries of the Gueldres Rose (*Viburnum Opulus*).

Mr. W. B. Smith, surgeon, deposed that he had made a post-mortem examination of the body, assisted by Dr. Williams. They could discover no natural cause of death; he inferred that death must have been caused by the absorption of the active principle of some narcotic poison. Dr. Taylor, in his work on toxicology, had stated that narcotic or vegetable, even

irritant or mineral poisons, could occasionally be taken and death be caused, yet no trace was left behind, nor any irritation. Generally, in the case of irritant poisons especially, there were traces; had there been any they must have seen them; they might be carried off by vomiting and purging. They found no traces of any poison whatever, nor anything to cause a natural death. The evidence was negative rather than positive. He inferred from this and the symptoms he observed during the child's illness, and from all the surrounding circumstances of the case, that death resulted from some narcotic poison.

Dr. Williams fully agreed with Mr. Smith's evidence, and said there was not very much known of the berries of the Gueldres Rose, and in toxicological works they were not said to be poison. But he had made experiments within the last few days, and was now able to state that these berries were poisonous if taken internally, but at present he could not say how long it would take for them to operate fatally after taken into the system.

Other evidence threw no light upon the subject, after which the Coroner summed up, and the jury returned a verdict "That deceased died of narcotic poison, but there is no evidence to show what that poison was or how it came into the system." Dr. Williams said he was conducting further experiments with relation to these berries, their properties, and their effects, &c.

BOUQUETS.

I advise that no bouquets of real flowers should be employed—one gets tired of the unvarying scents of Roses, Violets, and Heliotropes. I have a bouquet of artificial flowers so exquisitely made that they cannot be known from real flowers, and I put on them any perfume I like, and change the perfume whenever I please.—F. C. S.

["Tired of the scents of Roses, Violets, and Heliotropes!" If you ever become wearied with the sun's light, perhaps you will apply to the American tallow chandler who apologises to that luminary for having candles that are more brilliant. We will add a narrative, also from an American source.

TO BE PITIED.

I happened lately to be in the room with a semi-invalid, when a handful of choice flowers, the gift of a thoughtful neighbour, was brought in by her niece.

"See, aunt," said the young girl, "what a lovely bouquet Mrs. M— has sent you."

"Do you call that a bouquet? To my notion it is about big enough for a nosegay," was the querulous reply.

"Oh, yes, a nosegay; that is a better name, and it fully deserves it, for it is as fragrant as it is beautiful. Smell that Heliotrope, now."

"I don't think there is anything particularly beautiful in a Heliotrope; I call it a very plain flower, and then it wilts very quickly in water."

"Well, there's a Lady Washington—that will grow and blossom in water for days."

"Yes; but that ain't fragrant. I don't care much for flowers without fragrance."

"You love the Rose, then, the queen of the flowers," pursued the niece, who seemed determined to make her aunt say something pleasant. "That has beauty and fragrance, too."

"A very original remark, my dear!" was the severe reply. "For my part, I got tired of hearing the Rose called the queen of the flowers when I was a little girl, just as if queens have any more beauty or fragrance than other people. I have never seen a Rose since, but what I have thought of the invidious comparison. And there's the Carnation. Such a name!"

Just here I stammered out some apology, and made my escape. I wanted to keep some of my darlings unsullied. It does seem, when you are in company with some people, as though they would not leave you one beautiful thing to enjoy.]

Wilson brought up the report of the Public Petitions Committee on the petition of thirteen inhabitants of the province of Canterbury, praying for the repeal of the Canterbury Thistle Ordinance, 1866.

Mr. Rolleston moved that the report be printed. In the debate which ensued on this motion,

Mr. Stafford said that he believed it was absolutely impossible to prevent the spread of Thistles, and that a great deal of money was spent in doing only what would be like a drop in the ocean. He had, perhaps, peculiar opinions on the subject, but he believed that Thistles were really no injury to a country, but were a great improvement to second and third-rate land; so much so, that a friend of his had, in reclaiming third-rate land, actually sowed Thistles on it as fertilisers, and valuable Grasses were induced to grow when the Thistles died out, which they did in a short time where the ground was not ploughed.

Mr. Kerr, in referring to this statement, said that he knew that at Panmure, in the province of Auckland, the Thistles had taken complete possession of some very rich land, so much so that nothing else could grow where they were.

Mr. Fitzherbert, after stating that the extirpation of Thistles was, in his opinion, absolutely impracticable in a country like New Zealand, abounding in waste land, and whose cultivated farms adjoined millions of acres owned by the natives, said that he thought the cutting down of Thistles on the waste lands was a great mistake in reference to pastoral lands. He could state from experience that during certain portions of the year the Thistle was an excellent article of food—that period when there was a lack of rain. At that time sheep fed with great advantage upon the flower of the Thistle, and it would, in his opinion, be a disadvantage if the Thistles were destroyed upon the waste lands. In addition to that, the Thistle, by boring down into the soil with its tap root, loosened it, and rendered it thereby much more capable of improvement. Where these immense beds of Thistles grew, they gradually gave way, and in time the place became covered with a thick growth of grass. He had paid considerable attention to this question, and in the eradication of Thistles he had seen great errors committed. Where, then, was the remedy for the complaints made? In England, there were cases where farmers brought actions against their neighbours who allowed Thistles to grow to the detriment of the farm land in the vicinity, and damages were recoverable at common law where neglect had been proved; but to have an inspector, and penalties laid down, would be, to his mind, a mistake, and would prove to some extent an act of oppression.

Mr. Rolleston's motion was eventually adopted.

THE GREAT PEAR ORCHARD OF SANTA CLARA COLLEGE, CALIFORNIA.

The grounds of the Santa Clara College contain many vigorous specimens of fruit and ornamental trees. In these gardens we see growing the Palm tree and the Olive, the last over forty years of age, while not far off is the Fig tree, one of the most beautiful of all ornamental shrubs while young. Yet we find here, amidst these evidences of tropical vegetation, a fine hedge of Arbor-Vitæ, 15 feet high—north and south in juxtaposition; how striking the contrast! In the same garden are gathered over one hundred varieties of Grapes, mostly foreign, thriving in the open air with the slightest attention, and all in fruit. As I looked upon the uniform success that attended the culture of the Grape here, where every Vine is sure to produce its fruit every year, where there is scarcely the possibility of a failure of a crop, and everything is almost as sure as the fixed laws of the Medes and Persians, I turn my thoughts backward to our Atlantic slope, where our vineyardists struggle on, year after year, hardly depending on more than one good crop out of every three, and where prices are constantly fluctuating; where early frost nips their fruit before it is all marketed; where mildew cuts short the health and productiveness of their Vines, and a score of discouragements, which form a remarkable contrast with the ease of the Californian grower; and yet we would hardly exchange places with him. Where Grapes thrive with such abundance, they are too cheap to be profitable. I suppose the average profits per acre of Grapes on the entire Pacific coast is 60 dols. per annum, and yet how common it is for our Eastern vineyards to yield from 200 to 600 dols. per acre. We suppose an acre of Concord, in full bearing, will not fall below 100 dols. nett, while at the low price of 10 cents per lb.; they will more often yield 200 to 300 dols.

At a little distance from the College itself is the enclosure containing the Pear orchard we have referred to. Here are now six hundred trees of about sixty years of age, laden down with the most astonishing crop of Pears we ever beheld. The trees, although old, would average about 30 feet in height, and have a diameter of 10 to 15 feet across the branches. All of these trees would average about a foot in diameter of the trunk, and we estimated a safe capacity of 5 to 10 bushels to

THISTLES NOT A NUISANCE EVERYWHERE!

We know that at the Antipodes—that is, about Australia, New Zealand, and islands thereabouts—the people are standing on our globe with the soles of their feet towards ours; we also know that when it is midsummer with us it is midwinter with them, and now it seems that Thistles with them are the cultivator's blessing. We extract the following from the *Otago Witness* :—

In the House of Representatives, on the 28th of July, Mr. Cracroft

each tree, while on many the production would be fully 5 barrels, Years ago, when fruit culture was not so widely extended as now, the produce of this orchard brought an annual income to the College of over 24,000 dols.; but now, so plentiful and cheap are fruits of all descriptions, that the best terms of sale last year could hardly reach above 100 dols., and thousands of bushels were left to rot on the ground, or fed the hogs. We estimated at least 5000 bushels of prime fruit upon the trees at the time of our visit, and if it could have enjoyed a market like New York the lowest value we could have placed upon it would have been 10,000 dols. It is now a worthless property as a productive investment, and already two hundred trees have been cut down, preparatory to the devotion of the land to other purposes. The varieties we noticed most freely grown are the Easter Beurré, Bergamot, Madeleine, President, Bartlett, Beurré Clairgeau, with a few of our most popular eastern sorts. The President Pear is perhaps the most productive of all, the branches hanging down completely covered with specimen Pears of fine size and colour. The Pear, as a fruit, is quite as successful here as the Grape. All varieties do well. The Californian horticulturist has none of the anxieties we Eastern fruit-growers feel whenever we make our selection of varieties. With us we are fearful of the blight, or anxious as to climate, soil, and popular preferences in the market; but in California the grower sticks his graft upon his tree, or his young shoot into the ground, and in less than eighteen months he has his crop of fruit as perfect and luxuriant

as heart can wish. Every variety succeeds, and only [needs careful planting and culture.

We notice that after the Pear trees have grown for ten or twelve years, their full stature seems to have been attained; they make little or no new wood growth, and seem to stand still, bearing themselves almost to death. Year after year they bear heavy crops without cessation, and it seems hardly possible they can stand such constant and tremendous strains without sooner or later exhibiting signs of exhaustion. However, most of the orchards are young. We see as yet no signs of decay or wearing out. The old orchard of the College is still a marvel of luxuriance.

Among these Pear trees are planted some beds of Strawberries. Time was when a little bed of half an acre yielded an income of 500 dols. per annum, but that time has passed, and now the most they can obtain is but 60 dols. Their berries are large and splendidly coloured. The Wilson, particularly, we would hardly recognise. It has the same shape, but changes its dark red colour into one of brilliant crimson; loses some of its firmness, and almost all of its acidity. We found it here quite agreeable eating, pleasant and spicy, with but little sourness or tartness. Still it is not their most successful variety. The Longworth's Prolific is far more popular and profitable.

They begin picking the fruit about the 1st of May, and it continues ripening down to the 1st of November. As high as 10,000 lbs. have been gathered from three-quarters of an acre.— (*Horticulturist.*)

CASTLE HOWARD.

THE SEAT OF THE EARL OF CARLISLE, NEAR YORK.

No. 1.

CASTLE HOWARD is finely situated in an extensive park. Dignified and majestic in a very high degree, this magnificent building is worthy of its position and its surroundings with which it is in complete harmony. To those at all acquainted with architectural history, Castle Howard recalls a time when many noble mansions were built, in the designing of which a prominent part was taken by its architect, Sir John Vanbrugh,

post and dramatist as well as architect. This noble pile forms a fitting shrine for the rare and costly collection of art treasures with which its stately apartments are so richly decorated. The walls are crowded with paintings by many a famous hand, and I believe I am correct in stating that the interior of the cupola was painted by Antonio Pelligrini, a contemporary of the famous Sir James Thornhill. The south front (*fig. 1*), is

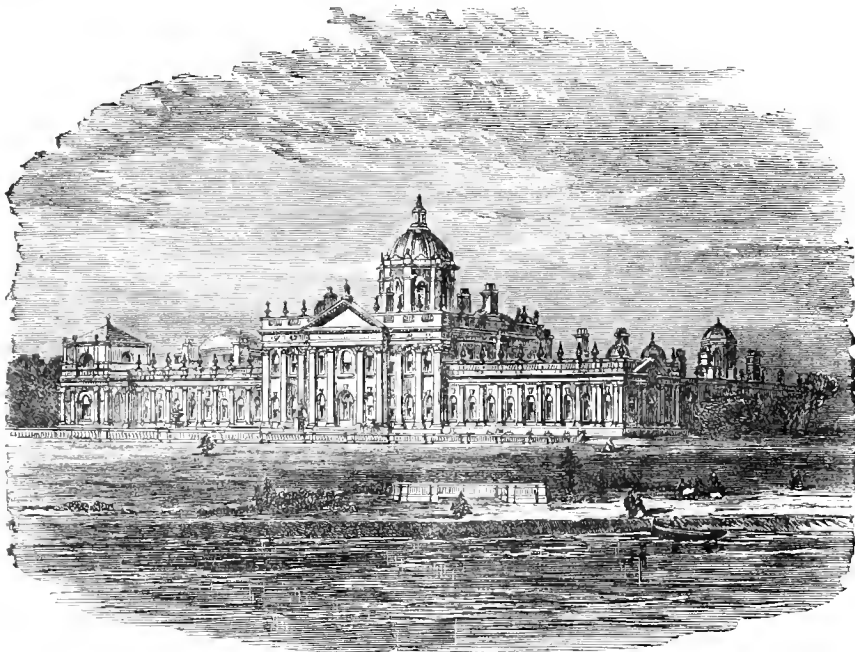

Fig. 1.—Castle Howard, south front.

richly embellished with Corinthian columns, statuary, and balustrading, and a fine flight of steps leads up to the grand entrance, past which sweeps a noble carriage drive in a straight line of half a mile.

Viewed from this position, overlooking the lake and pleasant undulations of the park, the scenery is very fine. The lake is a magnificent sheet of water, nearly one hundred acres in

extent, and from all sides of it the park rises gently, swelling into banks, agreeably diversified with finely-disposed groups of noble timber trees. An important feature in the view beyond the lake is the Mausoleum, (*fig. 2*), designed by Nicholas Hawksmoor, a pupil of Wren, and an assistant of Vanbrugh's in building Castle Howard. The position is well chosen, and the dense masses of umbrageous foliage on each side, while not approaching

sufficiently near to obstruct the view or mar the dignity of its appearance, yet serve to impart an air of retirement and solemnity to this abode of death.

There are no abrupt eminences nor steep declivities here, but that broad expansiveness, both in the green turf and the water, that aspect of grandeur and importance, so well in keeping with

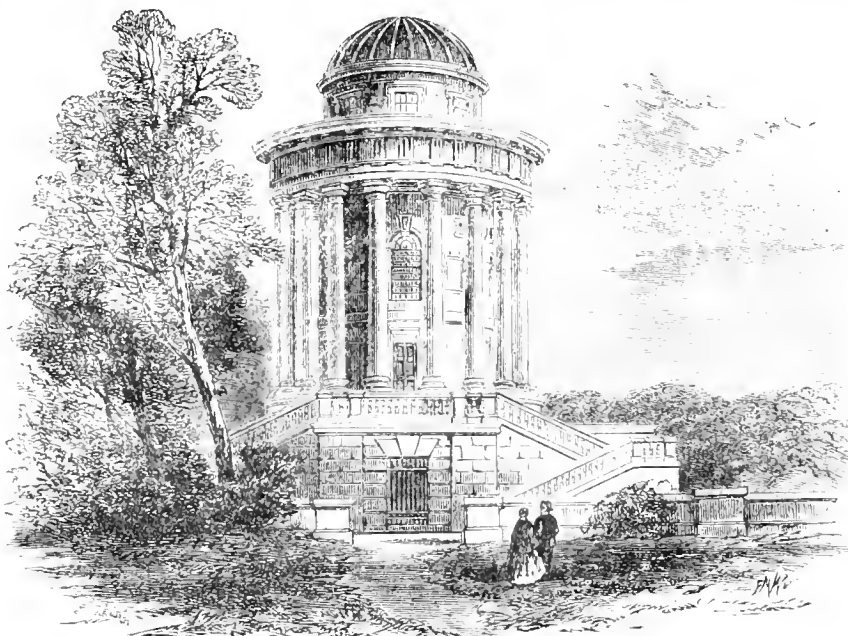

Fig. 2.—The Mausoleum.

those noble old trees which, like a gallery of quaint old portraits, tell of generations and times long since past.

To the right of the lake, and immediately opposite the south front, is the flower garden (fig. 3). This view will serve to convey some idea of its large size and architectural embellishments,

consisting of balustrading, statuary, tazzas, and Grecian vases. The elegant building on the rising ground to the left is a Temple of Diana, which, with the bridge and a glimpse of the top of the Mausoleum towering over the trees, adds very much to the effect of the scene. The design of the flower garden

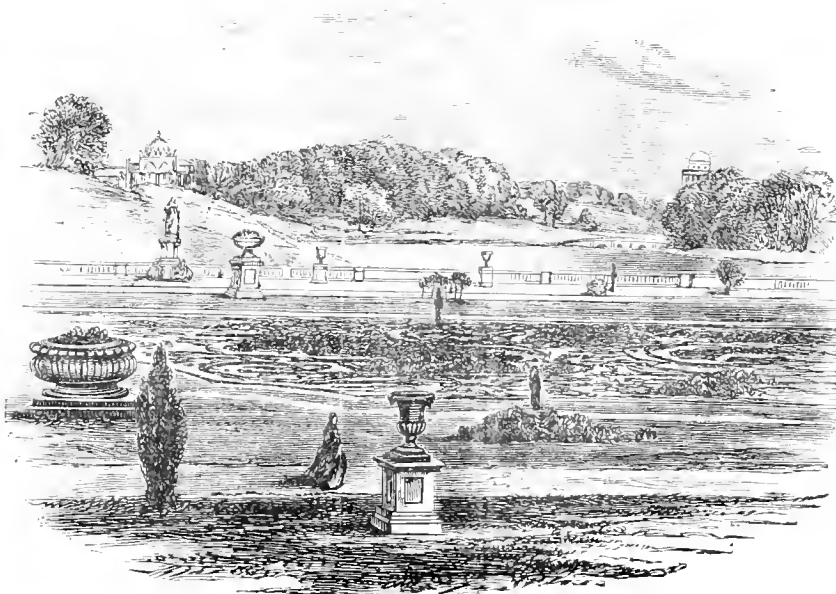

Fig. 3.—The Flower Garden.

consists of some elegant and very elaborate scrollwork in Box embroidery, the narrowest and most intricate parts of which contain Derbyshire spar, producing a chaste and pleasing effect. The scrollwork was connected with many large beds well filled with plants arranged in very good taste, the principal masses consisting of well-known varieties of Pelargonium. A mixed

bed of Pelargonium Le Grand and Countess of Warwick, with Verbena venosa, had a very good effect. Pelargonium Flower of Spring surrounded by Verbena Purple King, was equally fine. Golden Feather Pyrethrum was very bright and effective. During the past summer I have seen this useful plant largely grown in several gardens which I have visited in different parts

of England, and it invariably presented a most satisfactory appearance. This is noteworthy, because from the ease with which a large stock of it may be raised in spring from seed, it must be a very valuable bedding plant, especially to those who have but little glass accommodation.—EDWARD LOCKHURST, *Old Lands, Buxted, Sussex.*

WORK FOR THE WEEK.

KITCHEN GARDEN.

THE Globe Artichokes should now have some of the superfluous leaves cut away, and the stems earthed-up 6 or 8 inches. Surround the plants with recently fallen leaves, and cover these with soil, forming a sort of mound; then thrust a wisp of straw or hay in the centre of the crown. Take up the *Jerusalem Artichokes* and house them dry in a dry shed. *Cauliflowers* in head should be taken up and heeled-in close together, covering them with long litter in severe weather.

FLOWER GARDEN.

Let the planting of autumn bulbs be completed as soon as possible. Take up all Dahlias when the tops are frosted; do not clear too much soil from them, it will prove a protection if dried upon them. Strong tubers should be in a warm and airy place in order to get them thoroughly dry; weak ones must be potted or covered with dry soil. Neapolitan Violets should be thoroughly cleansed from weeds, runners, and dead leaves, and have a considerable quantity of dry sand strewed amongst them. This will prevent the ravages of the slugs. Out of doors they must have hoops and mats. Plant out Hollyhocks and other biennials. This is an excellent planting season. Where the ground is duly prepared not a moment should be lost; pruning, thinning, &c., can be done in frosty weather, not so planting. Tulips, as a matter of course, are all planted, and few seasons has occurred in which, to use florists' phraseology, "they have gone in so well." I would advise precautions being taken, as many of the bulbs are in a certain degree affected by the serious mildew which attacked the foliage last season. It will, therefore, be advisable to keep the beds as dry as possible for a few weeks, or, at least, to give the bulbs time to form plenty of roots previous to exposing the beds to the weather. This may be done by covering with mats, &c., during wet weather. Carnations and Picotees had better remain where they are till spring. I am no advocate for their removal in November. Those which are potted off should have the air at all times, and if they have had plenty of exposure hitherto, slight frosts will not affect them. Auriculas, also, should be nursed as little as possible; give only a small quantity of water, and keep them out of the way of drip. Attend to compost heaps, and collect leaves, &c., for next year.

GREENHOUSE AND CONSERVATORY.

At this time of the year it is of the utmost importance to arrange stock in houses so as to give a due proportion of light to each kind of plants, remembering especially those from brighter skies. All retarded autumn flowers should have a situation as much exposed to light as possible—near the glass, and not far from a quiet ventilation. Such plants as the following will deserve attention in this respect:—*Euphorbia jacquiniiflora*, *Eranthemum pulchellum*, *Geissomeria longiflora*, the *Heliotrope*, *Aphelandra cristata*, *Gesnera zebra* and *bulbosa*, *Geraniums*, *Centradenia roses*, *Linum trigynum*, *Mignonette*, *Salvias*, *Calceolarias*, *Cyclamens*, *Cinerarias*, and *Verbenas*. These, if attended to as previously directed, will be gay for weeks, and with *Chrysanthemums*, *Roses*, and *Camellias*, will prevent any blank occurring between the autumn flowers and those of the spring forcing. Above all, let every glass sash receive a thorough washing immediately. Those who underestimate the importance of clean glass in gardening have yet much to learn. In order to keep the glass clean as long as possible, let mats and coverings of all kinds be constantly suspended on rails or posts. This is absolutely necessary, both for the sake of the glass and the sake of economy, as Russian mats are rather expensive. A well-managed conservatory should now boast of a finer display than at any other period of the year. The charming contrast between the dark and glossy leaves of healthy *Camellias* and their lively-coloured flowers, the delightful perfume and gay tints of the *Bourbon*, *Hybrid Chins*, and *Hybrid Perpetual Roses*, with the exuberant and dashing style of the Chinese *Chrysanthemums*, will even unassisted produce a gorgeous effect. Keep a mild and genial atmosphere of 50° to 60° by day, sinking to 45° at night. Let the floors or some portion of the house receive a sprinkling in the evening,

provided a little back air can be given to prevent drip. Syringing is, of course, out of the question. In the mixed greenhouse the Chinese *Primroses* may be removed to a shelf as near the glass as possible, with plenty of air at all favourable opportunities. Herbaceous *Calceolarias* should be treated in a similar manner, and duly attended to with water. *Cinerarias* must be protected from the ravages of green fly by fumigations of tobacco, or by syringing with tobacco water. Some late-flowering varieties of *Heaths* and *Epacrises* will now be growing rather freely, especially those which have received late shifts, great caution in watering them will therefore be necessary. A few *Epacrises*, such as *autumnalis*, will soon become gay with flowers, and are worthy of every encouragement. Should mildew attack any of them slightly dust them immediately with flowers of sulphur. If any of the beautiful tribe of *Tropaeolums*, particularly *tricolorum* and *brachyceras*, which flowered early in the season, begin to grow, they should not be checked, but allowed to grow slowly through the winter; but if there is no appearance of growth, which is best for their future success, the roots should be kept inactive in a cool place, with the soil about them quite dry, and protected from mice.

STOVE.

Stove plants in general as before. Let those *Orchids* which have completed a good summer's growth, and which are somewhat inclined to be deciduous, sink gradually into repose. Those evergreen kinds, as some of the *Dendrobiums*, the *Aërides*, *Saccolabiums*, *Vandas*, &c., on blocks or in baskets, should be lowered a little from the roof, if too near, in order to escape the vicissitudes of temperature to which that situation would expose them in winter.

COLD PITS AND FRAMES.

In the case of cold pits, the time has now arrived for putting in readiness straw shutters, or whatever else it may be intended to use for coverings for them. Straw shutters, if well made, are expensive in the first instance, but are considered by many to be the most efficient of any kind of covering in use, and taking into account the time they last, they are, perhaps, as cheap as any. Expose the stock in such pits to air on every favourable opportunity, so as to check growth and consolidate the wood. The time is at hand when ungenial weather will frequently drive the labourer in-doors, and a stock of work should now be provided for such occasions. The tying of new mats, cutting and picking straws for the walls, cleaning old nails, drawing bast for the next summer, the arrangement of herbs, examining stores, making flower sticks and labels, washing and putting away all spare striking and other glasses, making straw or reed mat-protectors for tender plants, as well as making a stock of besoms and baskets for the ensuing year—are matters of as great consideration as out-door business, and should be proceeded with as soon as possible. Gardeners and amateurs should purchase a liberal stock of Russian mats at this period; in fact, a twelvemonth's supply. These will at once furnish a little in-door labour. Willows should be instantly procured for basketing, and a good stock of cloth for shred-cutting. All superfluous or dead plants in pots should be emptied out, and the dirty pots from every part placed in a corner of the shed, ready for washing in bad weather. Plenty of broken pots should also be housed in a shed corner, to be crushed and sorted in bad weather; they may be fairly reckoned amongst the most important matters connected with the potting-shed. Anyone having old half-worn sashes without glass, may readily make a most useful straw cover of them, well adapted for protecting *Endives* and other salad, *Parsley*, &c., as also for covering early crops of *Potatoes*, *Radishes*, and *Carrots*. They can be made on a couple of tressles. The straw (that of Rye, if possible) is drawn through the hands in bunches, and laid across the longitudinal bars of the sash regularly. When covered equally, three or four long sticks or laths are placed on it in a line with the sashbars, and bound down to the latter with pitched cord. It housed when out of use they will last a couple of years.—W. KEANE.

DOINGS OF THE LAST WEEK.

KITCHEN GARDEN.

Laying Down Strong Broccoli, &c—But for a press of other work, and the unsettled state of the weather, we should have nearly finished this. It is best done on a regular system. The intention is not so much to stunt or cripple the plants in their growth as to protect the stems and heads from frost. By earthing-up, and protecting the heads with a little litter in

severe weather, we have had as fine, or rather finer, heads than when we laid them down, but with a little more trouble. As a rule, if possible the head of the plant should be depressed to the north, and if that does not suit, then let it be laid to the west—the directions in which it is less likely to be acted upon by the morning sun, and therefore so far a security against sudden changes. In laying, begin at one end of a row, take out some earth a foot or so from the base of the plant, and a little, but to a less depth, close to the stem, so as not to injure the roots much; press the head of the plant down without breaking it, and then from the front of the next plant place earth over the stem of the first plant, and so on until all are done. Some dwarf sorts need no laying, and, as stated above, the system is more required in the north than in the south. The leaves laid aslant greatly protect the young head or heart.

Cauliflowers.—The late Cauliflowers, owing to the rain after the sewage watering, have proved very fine this autumn, yielding fine, large, symmetrical heads. Before much frost comes we shall place a lot of young stuff in earth pits to receive protection. Where there is a dry shed, Cauliflower, though it will not look so fresh as that cut from a pit with its green leaves, will keep well and be serviceable for many purposes, if, whilst the heads are still close and compact, the leaves are all stripped off, and the stems cut off, say, 9 inches or more in length, and stuck in earth and sand that is damp rather than dry. The position should be airy, when desirable, be kept free from frost, and but little light should be admitted.

We planted out young plants under hand-lights. It is well that the ground should not be too rich at first, as plenty of enriching matter can be added in spring. We shall try to make use of an old frame or an earth pit for pricking out a lot to stand the winter. For all such purposes we find after planting, an open rough surface, such as sand, is of importance alike for preventing damping and keeping off slugs, &c. Rough charcoal dust, or rough small coal ashes, are also good. Fine ashes are of little or no use in this respect. A lot of plants may now be potted and placed where they may have a little protection. Many are often saved in good condition if pricked out rather thickly at the foot of a wall or fence, the one helping to protect the other, and then when transplanted in spring they come in for the second or third succession.

Potatoes and Root Crops.—Great quantities of Potatoes have been much injured this season by leaving them in the ground so long as to let them have a second growth; otherwise the crops in general have been fine—of good quality and great in quantity. A little lime is very beneficial in all old gardens, also in all stiff clay soils. Carrots, Beet, Scorzonera, &c., will now be better out of the ground than in it. When scarce of dry stuff and storage room, we have found no plan better in a close shed than building them in layers, with dry small faggot wood between them. It is of great importance to take up all these things in dry weather, and to sort them for use according to quality and size. Spruce and larch twigs dried are good for this purpose. By no means use sawdust, as some people recommend. Whatever kind of wood it comes from, and however dry it may be, it is sure to taint the roots; and then by absorbing moisture from them the whole mass will heat, and there may easily be, if not constantly examined, a mass of rotteness instead of wholesome food.

Celery.—The youngest is still growing in these showery days, and the farthest advanced was made safe in dry weather. As we had no ashes to fall back upon, we have used a heap of burnt rubbish, burnt clay, &c., to put immediately round the plants in beds, filling up to the necessary height with the surrounding earth, made fine by breaking and pulverising. This thin casing, given as lately detailed, keeps the stems drier, and, to a certain extent, keeps worms, snails, and slugs from marking them. In stiff ground, but for harbouring snails and slugs, it would be advisable to finish the blanching process with moss, clean litter, dry tree leaves, &c. Sometimes we have used some of these, and just dusted them over with rough ashes. Dry tree leaves put on not so thickly as to heat at all answer admirably, they keep out frost so well, and even in a wide bed they soon cake on the surface, so that when laid on with a proper slope rain passes off them as if from the wing of a duck.

Lettuces.—We took up a number of good plants and put them in an earth pit, where they could be protected; the earth pit just being cleared of bedding plants, as they are removed to the dormant fruiting houses, where they will be more safe for a few months of the worst part of the year. Pricked-out Lettuces to give them a chance of standing, and sometimes they do better in the open ground than at the foot of fences or on

the sides of raised banks. The young plants on sloping banks are growing rather too freely since the showery weather came.

Endive we covered with dry leaves, slates, &c., to bring it in for use along with the Lettuces. Though most people like Lettuces better, yet the Endive looks very nice in the salad bowl.

Rhubarb and Sea-kale.—There has been little time taken or needed in preparing these for forcing this season, as the dry weather of the summer caused their leaves to wither rather prematurely, but the buds seem very fair, and will no doubt do good service when called upon. *Asparagus* is now fully ripe, and will be cleared off as soon as we can find time. Some correspondents have been inquiring as to giving salt to these seaside vegetables now, and we would say that a little sprinkling would do no harm, and if kept from the buds of Sea-kale, it would prevent slugs and even birds from touching them much. There is no better deterrent to soft-skinned intruders than salt where it can be applied with safety; and we have noticed that mice and birds have turned away from such things as Sea-kale buds because they found the soil near them saline. The chief time to apply salt is, however, after growth has freely commenced; in fact, could we do it, we would liquid-manure these plants in summer, and a little salt and mulching then would answer well. The summer, especially such as the last, forces us to let the above plants take their chance, except giving a sprinkling of salt, and we often notice how comfortably moist the ground of the *Asparagus* and *Sea-kale* is, contrasted with other crops, merely from the sprinkling of salt given in the middle of June. When a piece of *Asparagus* is to be raised for forcing, it will pay well to gather little or nothing from that piece in the preceding spring and summer. It will thus ripen and rest earlier. Such may well be expected to do better than an old exhausted bed; done away with as the worst, but "good enough" to be forced. Vegetables to be forced cannot be too good of their kind if the gathered produce is to be good in quality and quantity.

We do not intend commencing forcing *Asparagus* and *Sea-kale* just yet, having a regard to our stock, but frequently we have had both in fair condition by the middle of November. *Rhubarb* we have never had so early. Treat it as we may, that is not good in proportion to the others. Contrary to either *Sea-kale* or *Rhubarb*, *Asparagus* likes air and light to attain colour, but we have frequently forced it in the dark, cut it when 6 or 7 inches long, and set the bottoms in damp sand or moss close to the glass in a warm greenhouse for two or three days to give it a little colour. A great check in temperature in forced *Asparagus* is apt to make it hard instead of sweet and juicy.

FRUIT DEPARTMENT.

There are but few traces now of the dry season, but some of its results, as the absence of our late Peas, are felt. Strawberry plants planted out and turned out of pots still present a stunted appearance. We lost whole rows of some large turned-out plants, even after they received one or two waterings, and were shaded with evergreen boughs when water could not be given. Plants in pots were supplied with liquid of some sort, as they could not do without it, though even these Strawberry pots we had frequently to shade to save the watering we could not give. These, however, partly owing to the sewage given, are rather stronger than we like to see them.

We have said so much of cleaning, &c., lately, that we will just add one word on the keeping of late Grapes. In mild weather it will be advisable to give a little fire heat every day, and chiefly in the day, with air early given, or rather kept on night and day when there is no frost. Drip must also be avoided. Drip is easily got rid of in large squared fixed-roof houses. In old houses with the old form of rafters, even though the glass and putty are sound, much drip often comes from the rafter, first from the want of a deep plough-line in the centre of the rest of the rafter for securing the sash; and secondly, from that line becoming choked-up in time from dirt and dust.

ORNAMENTAL DEPARTMENT.

Referring to previous notices, we shall just allude to two matters. First, to direct the attention of young gardeners to diagram no. 3, page 301, as to the mode of making a perpendicular cut for Box edgings. It is more easily made bevelled, and is too often done so, and the consequence is the gravel has more earth at the sides, and is more troubled with earth heaps.

The second matter is, we are now inserting in a cold pit our *Calceolaria cuttings* for next season. The mode has frequently

been described. We never let them have a pot. We prick them out in fresh sandy loam in rows 2 inches apart, and 1 inch from each other in the row. We like them best to root little until after Christmas, and by the middle of March we transplant into earth pits from 4 to 9 inches apart, where they can receive a little protection when necessary, and then we lift them with balls as fine strong plants in May. The plants growing in the beds, we do not require to plant them so early merely to get room or avoid watering. *Amplicaulis* will not stand so much cold and damp as the others; in fact, unlike most other things, *Calceolarias* for beds seldom feel the effects of damp. A cool moist soil and a bright sun are their delight. Notwithstanding the dry summer, *Calceolarias* succeeded almost as well with us as *Geraniums*. That was greatly owing to mulching, which kept the roots cool. Even now (October 29th), many plants are pretty full of bloom. For cuttings we prefer small side shoots about 2 inches in length.—R. F.

TO CORRESPONDENTS.

N.B.—Many questions must remain unanswered until next week.

THE REV. W. F. RADCLIFFE requests us to say that his direction is Okeford Fitzpaine, near Shillingstone, and not near Blandford.

MEDICAL QUALITIES OF BRITISH PLANTS (*D. H.*).—Dr. Thornton's "Family Herbal" contains the information you seek.

PARK AND GARDEN (*Latent*).—It is impossible to suggest the proportions the park, lawn, flower garden, kitchen garden, and shrubberies should occupy in forty acres, without knowing the tastes, requirements, and pecuniary means of the family.

ADVICE ASKED (*A Youthful Aspirant*).—The little Manuals published at our office are useful. In addition to them we would advise you to obtain the "Science and Practice of Gardening," price 3s. When you have mastered these obtain "The Cottage Gardener's Dictionary," and when you can spare the money, "The Gardener's Assistant," by Robert Thompson, which is 31s. 6d. By the time you have studied the smaller of these works you would be able to ascertain better the bent of your own mind. As you are only nineteen, you would not find much difficulty in getting in as under gardener to a large garden, more especially if your employer would recommend you to one of our large nurserymen. As, however, you have done well in a small place, we should hardly like to advise you how to act, as with prudence you may work your way from your present place to a larger one, and then to one larger still. Though by thus acting your wages ultimately may be much less than those holding the best places, you must recollect that all along you would be getting much better pay than a mere improving young gardener could hope to expect. In most small good places the gardener is paid for his work. Improving young gardeners we say nothing in defence of the system, but merely look at it as it is) must ever consider the means of improvement as a part of their pay.

TRANSPLANTING LARGE PAMPAS GRASS (*W. T.*).—The best time in our opinion to move the large Pampas Grass would be at the end of March next year. It might be moved now if you could make sure of a good ball, on which depends the success of the operation now or in spring. The grass should not be cut away if the plant is moved at this season. It ought to remain until the beginning of April.

REPOTTING ROSES (*Idem*).—Pot them now, and place them in a cold pit, giving plenty of air. As they have not been potted off two years you could not do worse than give them a large shift. We advise a moderate shift, removing as much of the old soil as can well be done, care being taken of the roots. The plants will flower in March in the greenhouse.

FRENCH PELARONIUMS TO FLOWER AT EASTER (*Idem*).—The plants should at once be shifted into 4½-inch pots, and have a light airy position in a house with a temperature of from 40° to 45° from fire heat, and at the end of December they should have their blooming pots (6-inch). They should not be stopped after this, and after February they should have a temperature of from 50° to 55° from fire heat, affording them abundance of air and light, and keeping the shoots regulated.

CUTTING OUT THE WOOD OF ROSES (*E. F. W.*).—We approve of your now cutting out the old, weak, useless wood, and also thinning the shoots, deferring the principal pruning until February or as soon after as the weather is mild. You may, however, do all in spring.

ARBITUS PROCERA TRANSPLANTING (*J. R.*).—This is a good time to remove evergreen shrubs; but as you are thinning out, perhaps you will remove it to a more open situation, to which case the plants, from losing the shelter they had when close together, are liable to be somewhat injured by the wind and severe frosts after planting. We consider the beginning of March a good time to move the *Arbutus*, and better than late in autumn. The best time of all is the end of summer or early in autumn, as soon as the ground becomes moist and the growth of the plants is completed and the wood firm.

PLANTS FOR A NORTH BORDER (*Mrs. B.*).—There is little hope of getting anything to grow where Ivy does not; but we have found *Cotoneaster microphylla* do well on a north border, and the Spurge Laurel, *Alexandrian Laurel*, *Dutch's Broom*, *Berberis dulcis*, *Vincas major* and minor, and the gold and silver varieties of the last; *V. elegantissima* being very fine, and doing well almost everywhere. *Skimmia japonica* will grow in a shaded border, and is finer there than in a sunny one. *Aucuba japonica* is also good. We have no doubt if you give the above a fair amount of soil, and tolerably rich, that they would do well.

POTATO-GROWING FOR THE LONDON MARKET (*A Novice*).—You do not say whether you intend growing early or second early sorts, but we presume both. Ashleaf and Myatt's Prolific we advise for early crops, and Lapstone and Early Oxford as second early sorts. The first three are kidneys, and the last a round kind. They are good croppers, and of excellent quality. The Potatoes would be best sent to market in hampers

—indeed that is the only suitable way of sending the early and second early sorts before they are ripe or have the skins fixed. Apply to a dealer in the Borough Market.

EARLY PEAS AND POTATOES FOR MARKET (*A Subscriber*).—Sangater's No. 1 or Daniel O'Rourke is the best early Pea; but Emperor or Morning Star is preferred by many on account of its free bearing, though it is not more so than the former. A pint will sow a row 20 yards long, and if the rows are 3 feet apart you will require about 3½ bushels per acre. The best early Potato for the open ground is Myatt's Prolific Ashleaf; but the old Ashleaf comes in about a week or ten days earlier.

WINTERING FANCY PELARONIUMS (*An Amateur, Halifax*).—Without a greenhouse it is difficult to winter these plants. Your only plan will be to keep them dry, not giving them any water beyond that needed to keep the leaves from drying, and you cannot keep them too near the glass as long as they are safe from frost. We think the plants have gone off through damp. For mixing with blood to apply to Apple and Cherry trees, we know of nothing better than dry soil.

BRICK DUST FOR UPLAND PASTURE (*East Norfolk*).—If made very fine it may be of some benefit, but we question very much its utility unless the soil is heavy. Upland pastures are generally too dry already, without adding anything of a nature calculated to burn in dry hot periods.

GRAPES NOT KEEPING (*H. P.*).—Many would be quite satisfied with such fine Grapes up to this time, from starting in March, though they would not keep until January. The good keeping depends on the Grapes getting ripe, but not over-ripe, in autumn, giving them plenty of air of a temperate character, and keeping them dry, but not parched. When fire heat is applied, air should also be given to prevent any resting of moisture on the berries. Your taking out all the plants, and keeping the house dry, would almost lead us to conclude that the damping and going-off are partly owing to over-ripeness after such a bright summer, but chiefly owing to the damp that you say enters the house, we presume from broken or cracked sashes, or exhausted puttying. See page 326 on these matters. If dews or rains get in over the bunches, it is next to impossible to keep them fresh.

VINES IN A GREENHOUSE (*Henri, Lisburn, Ireland*).—For your greenhouse vineery we would not have more than four Vines—viz, two of Black Hamburg, one Buckland Sweetwater, and one Muscat Hamburg or Royal Muscadine. The border for the Vines we would make either chiefly or altogether on the surface of the present soil, and nothing is better than fresh loam from the top of a pasture which has been well exposed to the air, enriched with broken bones, and kept open with a little charcoal and rough lime rubbish. If we knew the circumstances and the position of the border we might say more. See the "Vine Manual," which you may have by post from our office for 2s. 8d.

POT VINES (*A. R. Q.*).—The Vines you intend for fruiting next year ought to be potted now if they are in less pots than those 11 inches in diameter; and in potting, the roots should not be disturbed, merely loosening the sides of the ball, and removing any loose soil; 13 or 15-inch pots are not too large. We think potting after they showed fruit would prevent its swelling, and planting in an outside border and fruiting the Vines the same season, we think would not prove successful. If you plant them out, their roots should be disentangled and spread out, and they should not be allowed to bear fruit the first season.

KEEPING BERBERIES ON THE STEMS (*Berberry*).—Is it the common Berberry you mean? The fruit is apt to fall, but we have known it kept for a long time by cutting the twigs before the fruit was quite ripe, and setting them in sand in a dry, cool place, and when the leaves decayed taking them off, and running weak gum arabic along the base of the fruit. The splendid winter plant, *Crataegus Pyracantha*, can generally be obtained without any trouble, as birds seldom meddle with it. The dark purple berries of the evergreen Berberry, *Berberis Aquifolium*, often stand well through the winter.

BEES ON TREE (*Rector, Dorset*).—We approve generally of the proposed mode of arrangement. Your blank wall of the school-house would look well if covered with *Cotoneaster microphylla*, or *Crataegus Pyracantha*. We fear that *Picea Pinus* would be too large for the position No 6, but if you have an Irish Yew at No. 2, you might have the same or a Juniper at No. 6. Then we would make 4 and 8 *Cupressus Lawsoniana*. No. 5, we would bring nearer to the walk to harmonise with 10, and if you had *Cotoneaster* against the wall, then 5 and 10 might be alike. We like the idea of the open space of lawn in the centre, and before the shrubs grew you might have little beds for flowers close to the walks.

ROOTS OF FIG TREES (*B. B.*).—It is not absolutely necessary to brick in the roots of Fig trees, but if the roots have free scope, they will be apt to grow too much, and the shoots will become too luxuriant for free bearing. We have seen Fig trees ripened with great propriety to check luxuriance. We have seen one half of a tree as distinguished for fertility as the other half was for barren luxuriance, because the one half had been nibbled with mice. Eighteen inches in depth, and from 3 to 4 feet in width, we consider space enough for a good-sized Fig tree. We have seen fine crops with no more width of soil than 3½ inches. This, however, must be kept in mind—the less the space enclosed the greater the care required in watering. If the soil becomes dry at critical times the fruit will drop to a certainty.

VERONICA (*Jonas*).—Several of the Veronics are now used for bedding purposes, and as we do not know whether you allude to the flowers or the foliage, we are at a loss as to what the variety is respecting which you wish for instructions. It may be one of the small shrubby kinds, mostly with blue flowers, and increased by cuttings of the growing parts inserted in sand in a gentle hotbed, except in July and August, when a close cold frame will do. There is a variety with "grey" or silver foliage—viz., *V. candida*, which is increased by division, and by cuttings or slips early in summer. Send us a specimen.

CRAIG'S PROLIFIC EARLY OCTOBER (*J. C.*).—We received a brace growing from one branchlet. They were nearly of similar length, 14 inches—the most serviceable of sizes. They were short-necked, blossom adhering, white-spined, quite straight and regular in form, flavour good.

FORMING A POND (*C. B. M.*).—The bottom and sides of the excavation should be taken out or down to a good hard bottom, and before putting in any clay, ram firmly. We would then put in a thin layer of dry clay and ram it firm, and this first layer should not exceed 3 inches thick. We would on it place about 2 inches deep of gravel and ram well down, then put on a layer of clay, adding water so as to make it ram well among

the gravel. It is bad practice to add too much water; all that is wanted is to get the clay to such a state as to ram well and firmly. Add layers of clay until you have a foot thick of hard rammed clay, and then you may finish off with about an inch of gravel. That is how we make ours.

IRISH YEW TRANSPLANTING (*Subscriber*).—Now is a good time for its removal, which may be easily done, taking care to preserve as much soil as possible about the roots. After planting, give a good watering to settle the soil about them. The Irish Yew is increased by seeds gathered now, laid in a heap until spring, and then sown in light soil, and many of them will grow next year, but some will not vegetate until the following season. It may also be increased by cuttings 6 or 8 inches in length taken off with a heel, which should be pared smooth; and after removing the leaves from the lower half insert the cuttings in sand in a shady border, and cover them with a hand-light. April and August are the most suitable times to put in cuttings. Seedling plants are best.

ADIANTUM CAPILLUS-VENERIS FRONDS BROWNING (*Idem*).—We think the browning of the fronds is owing to the plants being covered with the bell-glass, which we suppose is not taken off daily and the inside wiped dry. Before you report the plant try the effect of doing this. Remove the fronds which are most affected. You may report now, but we should prefer the beginning of March. You may sow the spores now with every chance of success, taking care to cover them with a bell-glass, and keep the surface constantly moist.

HONEYSUCKLE PROPAGATION (*C. W. D.*).—Now is a good time to put in cuttings. They should be of the ripened shoots of the current year cut into lengths of three joints each; two should be inserted in the soil, leaving but one above the surface. A sandy soil in a shady border is the most suitable position. If the joints are far apart the cuttings need only have two joints. The less of the cuttings out of the soil the better. Layers, however, are a more certain mode of propagation, and may be made now.

CLIMBERS FOR A NORTH WALL (*M. L. D.*).—The best plant for the mortar wall would be Ivy, which should be trained and nailed so as to keep it from falling if there is any likelihood of its doing so. *Cytisus microphylla* would answer for the cement wall, but it would be necessary to nail it; and, indeed, there are no plants that would cling to a cement wall without being secured against it. Both the Pampas Grass and *Tritonia aurea* would not succeed on a lawn at a high elevation and in an exposed position north of Lancaster. The *Tritonia* is with us a poor lawn plant, and we think you meant *Tritonia Uvaria*, which succeeds admirably much farther north, also the Pampas Grass except in bleak positions. Now is a good time to plant the creepers.

PLANTING PEAR TREES (*H. M., Dublin*).—Let the upper roots be no more than a foot below the surface, and mulch over them in summer. No planting is much worse than deep planting.

LABELED (*Ocorghina N.*).—Use zinc labels, and with a quill pen write on them with the following ink:—Sal ammoniac powder and verdigris, each 1 drachm, lampblack half a drachm, mixing with 10 drachms of water. The labels should previously be scoured with sand paper.

CINERARIAS FAILING (*A. Z.*).—We think that the soil you have grown them in is too poor and too light. Try the following compost:—Turfy loam from an upland pasture, two parts; fibrous peat, one part; decayed leaves, one part; very rotten cow dung, half a part; and a small addition of river sand. Water your present plants with weak liquid manure.

LEAVES FOR BOUQUETS.—The leaves of the Stag's-horn Smack may be preserved with all their beautiful autumnal tints by pressing them in a book. Such leaves make a splendid background for winter bouquets, and are very ornamental alone in vases for the mantelpiece.—G. BUNYARD, *Maidstone*.

SELECT INDIAN AZALEAS (*Colonel B.*).—Admiration, Brilliant, Cheloni, Criterion, Duc de Nassau, Etoile de Grand, Extracel, Flower of the Day, Ghodstanes formosa, Grand Duc Michel, Her Majesty, Iveryana, Kinghorni, Madame Mieliez, Mars, Stella, Vesavius, and Stanleyana. The *Pelargonium* you name are good.

ALLAMANDA VIOLACEA AND CULTURE (*J. Bayly*).—Like the rest of the genus it is a climber, but may be grown bushy. Its flowers are lilac-coloured, and open at the end of September and during October. It is a native of Brazil, and requires the same culture as the yellow-flowered species, thus well detailed by Mr. Williams in his "Choice Stove and Greenhouse Plants." "If allowed to make long growths they will require a trellis, the most desirable being that of a balloon shape; but the best system of growing these plants is to prune hard back in the spring, just before the buds start, after which the young shoots should be pinched back once or twice, to induce them to throw out laterals, and thus to make a bushy plant. When treated in this manner a few stakes only will be necessary to give them uniformity and symmetry in shape and appearance. The soil should be composed of equal parts fibrous loam, peat, leaf mould, and silver sand, with the addition of a little well-decayed manure. When potted, the plants should be placed in a temperature ranging from 65° to 75°, and as near the glass as possible, and they must be treated liberally with water from the syringe until October, when it must be gradually withheld. In spring they will want repotting, and to be again treated in the same way, when they will soon throw out blooming laterals. If required to bloom early they must be started early in the month of January." *A. violacea* seems to require a little more nourishment than the other species. Give it weak liquid manure once a week after the bloom buds are apparent.

HEATING A CONSERVATORY (*Wild Wind*).—You can heat the conservatory with the north aspect, provided, if the top of the boiler is a close one, the pipes in the house are higher, not lower than the boiler. If the boiler has an open top your flow pipe might be level all round, and 6 inches below the top of the boiler, the return entering near the bottom of the boiler. With a close boiler you can take the pipes pretty well as high as you like, if not higher than the feeding pipe or cistern, but you cannot take the hot water beneath the level of the boiler. The easiest mode for connecting the pipes with the boiler is to use 1-inch strong gas pipes to screw into the boiler; on these you could have taps. In such a house, besides Ferns and Mosses, you could grow Camellias and the fine-foliated Begonias, &c. Ferns, Mosses, and Begonias, with a few Dracenas, &c., would make an interesting house.

NAMES OF FRUITS (*A Twelve-years Subscriber*).—If your Grape is a Muscat, as you say it is, you must not expect it to ripen out of doors. It must not only be under glass but the house must be artificially heated.

(*B. B.*).—Apples: 2, Court-Pendu-Plat; 3, Franklin's Golden Pippin; 4, Reinette du Canada; 5, Court of Wick; 7, Golden Winter Pearmain. Pears: 1, Fondante d'Automne; 3, Aston Town; 4, Doyenne Masqué; 5, Doyenne Blanc. Others not recognised. The Pears were decayed. (*Della*).—Beurre Nantais. (*C. S.*).—1, Brookes' Pippin; 2, Christie's Pippin. (*W. Thomson*).—Not known, very astringent. (*J. M.*).—Api noir. Send a fresh specimen of the flower. (*An Old Subscriber*).—It is a very fine specimen of Warner's King. (*J. A. H., Suffolk*).—Pears: 17, Gloa Morceau; 8, White Doyenne; 15, Swan's Egg; 16, Dunmore; 13, Marie Louise; 9, Beurre de Racee. Apples: 6, Downton Pippin; 18, Scarlet Pearmain; 19, Coe's Golden Drop; 4, Cambridge Pippin; 7, Gros Faros; 5, Striped Holland Pippin; 1, Golden Noble; 3, Court-Pendu-Plat; 2, Nonpareil. (*H. S.*).—The Grape is one of the many vineyard varieties cultivated for the vintage only, and is neither cultivated nor worthy of cultivation in this country.

NAMES OF PLANTS (*H. Armytage*).—We cannot name plants from leaves only. No. 4 is *Berberis Darwinii*. (*W. M.*).—The same answer applies to your specimens. (*H. Mason*).—1, *Garrya elliptica*; 2, *Veronica spicata*; 3, cannot be identified from such specimens; 4, *Laminium maculatum*; 5, *Onithogalum albiaceum*, the "Onion plant" (*B. B.*).—1, *Escallonia imbrata*; 2, *Cupressus orientalis*; 3, *Phlo* is *Leonurus*. (*An Old Subscriber*). 1, *Garrya elliptica*. You ask if this shrub flowers. Certainly it does, and now and for some little time past is its season; indeed, the post has just brought us a flowering specimen to be named, which you can have by sending your address to the Editors; 2, *Bupleurum fruticosum*; 3, *Perinetia mucronata*. (*Halstead Correspondent*).—1, *Giulia coronopifolia*; 2, *Penstemon gentianoides*; 3, *Tricyrtis hirta* (*E. M. B., Enfield*).—Your plant is without doubt a species of *Bauhinia*, we should say it is *B. purpurea*, a native of India; if your seeds are from Demerara they cannot be from wild plants. (*A. M.*).—1, *Adiantum Capillus-Veneris*; 2, *Pteris longifolia*; 3, *Scolopendrium vulgare*, var. *convolvere*; 4, *Phloxis Lecouras*. (*Colonel Bingham*).—1, *Lastrea dilatata*; 2, *Doodia caudata*; 3, *Pteris serrulata*; 4, *Asplenium marinum*; 5, *Athyrium Filix-femina*, in a very young state.

POULTRY, BEE, AND PIGEON CHRONICLE.

PRIZES—JUDGING—REPORTING—BUYING.

My attention having been directed to a letter of Mr. L. Wright's, in the Journal of October 20th, in which he requests me by name to give an opinion on various subjects he mentions in reference to poultry shows, I comply with his request as plainly and briefly as possible.

In the first place, then, I am by long experience well assured, as Mr. L. Wright very correctly states, that too great a difference in the value of the prizes in each class materially lessens competition. To secure, therefore, the most entries, combined with the best pecuniary results to the show, if I had the regulation of £10 to each class I would divide it as follows—£4, £3, £2, £1, being four prizes, thus giving one extra chance of winning to each entry over our present general rules, and also bringing the prizes more in accordance with the relative perfection of the pens exhibited.

Mr. L. Wright proceeds to suggest the expediency of giving in "order of merit" all the highly commended pens, adding, "nothing could be more easy." I, on the contrary, contend nothing could be more difficult; nor do I conceive that any individual at all experienced in the arbitrations of a large show would by any possibility have urged such a suggestion. And why? Not unfrequently the time at first appointed renders it necessary that the arbitrations should be completed at the rate of something like one hundred pens an hour. Unlooked-for delays very often bring with them much abbreviation of the time first allotted; and yet, to add to this already too great restriction, Mr. Wright asks that the several highly commended pens in the majority of the classes as they happen to arise, shall be placed in their "relative order of merit," and repeats, "nothing could be more easy." It will, on the contrary, be only too vividly photographed on the memory of all practised judges, that the award of even a third prize often takes twice the time and trouble that was required to decide on the first and second prizes, and proportionably as you descend into the ranks of mediocrity so do the difficulties become greater and greater, until at length, as you get to the lowest grade, the Irishman's assertion quoted in Mr. Wright's letter becomes pretty near the fact—viz., "That one was as good another and a great deal better." Certainly, then, any judge would require fivefold the time at present given to overcome this increased difficulty, than which, Mr. Wright says, "nothing could be more easy." I am assured that a little personal practical experience, were he individually to try his proposed plan, would be all that is wanted to convince Mr. Wright of its utter impracticability; and I cannot but think he is now fruitlessly expending as much time and money upon this matter as he now admits he did in his efforts a year back respecting "trimming," which all of us disapprove; but some of the very first on the list of protestors proved among the very earliest to be

"caught," and "disqualified," for actually sewing cocks' combs through and through to keep them upright.

But many of our amateurs may ask—How can these things be remedied? I rejoice, by employing additional judges, and thus giving them sufficient time. Not, be it supposed, by sending three or four gentlemen together, for that only retards progress, but let each have his appointed section, allotting from sixty to seventy pens an hour in the general classes, and considerably more time to all varieties of Game fowls, as the majority of the best of these birds should be "handled." But at once this brings the almost general veto of committees. "Our receipts," say they, "do not allow of our employing more than one judge," even should he request simply his travelling expenses (which I know in the case of one official only is not at all unfrequently never refunded); therefore, these suggestions of extra arbitrators are at the first committee meeting usually thrown to the wind *in toto*, as "extra pull-backs."

To take notes on the spot as to the relative excellence of rival pens in large classes, coupled with time restricted, is impossible, and still more so to record simply from memory the varied characteristics of pen after pen of individual fowls in keen competition. My honest conviction is this, that many buyers of prize pens of poultry have to date their disappointment from one or other of two causes, either "claiming" without seeing the actual prize pens at certain shows, where, to the disgust of the arbitrator, he was compelled to give the prizes to the best birds there to keep faith with the exhibitors, as the committees express it, though very, very imperfect specimens indeed; or through the still more reprehensible practice of sending the money for them, as priced in the catalogue, after the birds were returned to the exhibitor and the show concluded. In the last-named case, oh! how often, in spite of my expostulations, as being no part of the legitimate duty to be expected from a poultry judge, have I been an involuntary witness to the most lively "change-ringing."

My concluding advice to buyers is this—If you want certain pens, examine them on the spot; if approved, claim them at once, and let them go directly through the committee, at the close of the show, to your own address.—EDWARD HEWITT.

WHITE DORKINGS.

It may be useful for poultry-fanciers who have given their attention to any one particular breed, to publish from time to time the results of their experience as a guide to others.

White Dorkings, an exceptionally beautiful variety, provided only they have a clean grass field to run in, have of late been much neglected. Few entries have been made at the principal shows, and consequently the prizes have been reduced in number and value; or the separate class has been abolished, and Whites have been forced to compete at great disadvantages with Coloured and Silver-Grey birds, so different in essential points. I think the breed has fallen into this disrepute from ignorance of its merits; and as my experience in it has drawn me to make a very different estimate of them to that usually given in poultry books, it may not be amiss to relate it.

1. As to their hardihood. It is stated in nearly all poultry books that White Dorkings are a delicate variety. I believe this idea arose from the old notion (an erroneous one, *me judice*), that all white birds are delicate. The earlier authors gave this as their opinion, and others have simply copied their remarks upon breeds in which they are not themselves learned. This I have found to be the greatest mistake. I seldom lose a chicken or have a sick bird. Early in the spring of this year, when, from some mysterious epidemic, I lost the whole of my young stock of Coloured and Silver-Grey Dorkings and Game Bantams, and even many Brahmas and Scotch Greys, of White Dorkings under the same hens I did not lose 1 in 8, and the earlier pullets have long been fine mature-looking hens. The breeding stock keep healthy through the year in a very small run, with two or three hours' exercise daily in a grass field, and rather more liberty at moulting time.

2. As to their laying properties. They are generally classed with other Dorkings as bad layers. This, too, in my yard has been proved an entire error. The pullets begin to lay at six or seven months old, produce more than twice as many eggs—large round ones of a pinkish colour—as Coloured or Silver-Grey birds, and often continue to lay through nine months in the year. They are almost non-sitters. Some steal their nests, hatch in a wood, and prove good mothers; but they hardly ever take to the nest in a house. I have hens of two years and a half old, which have never shown the slightest desire to sit.

3. As to size. Here they confessedly fall short of Coloured birds; yet last year I had cockerels weighing over 8 lbs. and pullets 5½ lbs. at seven months old. I do not think, however, that mature birds much exceed these weights, at least mine do not; but I believe there are other strains finer in mere size.

4. Their excellence for the table all allow.

Such is my experience. My stock originally came from a farm in Sussex, but it has been necessary to introduce fresh blood through a Birmingham prize cock, and the pullets from this cross lay smaller and whiter eggs. I may be peculiarly fortunate in this strain, but at least it is worth while letting others know that a breed ornamental beyond almost all others with their snowy plumage and coral-like combs, may also be made one of the most generally useful.—O. E. CRESSWELL.

POUTER PROSPECTS.

A most unfortunate fatality has brought into the space of seventeen days the three great Pouter Shows of the season—namely, the Scottish, the Birmingham, and the London; but none the less there are prospects of a competition keener and more advanced than ever.

Glasgow this year, in courtesy to a newly-formed Society, gives place to Edinburgh, at which latter city the great Scottish Exhibition will be held. The new Society maintains that amplitude of schedule in favour of standard birds so long in vogue at Glasgow, but with much judgment has provided two classes only for outside varieties—Mealies, Splashes, &c., hitherto, by a too profuse classification, placed almost on a par with birds of standard pretensions. This arrangement is a clear step in advance, and if persevered in will unfailingly promote the best interests of the Pouter and its admirers. The special prize instituted some years ago by Mr. Volkman for excellence of proportion and carriage, open to all the Pied classes, is transferred to Edinburgh, Mr. Ure keeping that gentleman company by offering a similar prize, so that both cocks and hens may have the benefit of an extra searching adjudication.

Birmingham also maintains its lately-enlarged classification, a proof that a correct principle will surely win its way. Yellow Pied Pouters, however, occupy a most equivocal position, being exiled to the "Any other colour" class, to keep company with Grizzles and Sandies. Whether this is intended as a degradation of Yellow Pieds (sometime the favourite colour), or the elevation of Pouter weeds to the level of standard birds, it is impossible to divine. The judges, however, should have something very trenchant to say in the matter, and by unflinchingly giving all the awards in this class to the standard Yellows, should relegate the weeds to their true position.

London creates astonishment by the energy it is displaying on behalf of a variety it has so long neglected. Hitherto Carriers and Almonds have all but monopolised its attention; but now, as though with a twinge of conscience, it is clearly setting about making up for lost time, and is endeavouring to win its way into favour by an almost lavish consideration of Pouter claims. Of the seventeen cups for Pigeons, four are devoted to Pouters alone. The classification is admirable, compact yet ample; and the prizes are so distributed as to secure the utmost respect for standard excellence. Fourteen classes now take the place of the six of last year, a result mainly brought about by a twenty-guinea fund inaugurated by Mr. Volkman, who, in addition to English donations, has received the heartiest support from Scotch friends and fanciers—a courtesy, we trust, foreshadowing more and more of mutual co-operation. The fund in question is supplemented by £30 from the Show Committee, and a five-guinea piece of plate from Mr. Ord. With a schedule so well constructed and furnished, it will be the fault and the loss of the fanciers themselves, both Scotch and English, should this opportunity be wasted of reviving the Pouter interest and widely extending the circle of his patrons. We hope, therefore, that the nave of the Crystal Palace, where the Pigeons will have the great advantage of being shown, will present a grand gathering of the best specimens from all points of the compass.

Pouters are clearly "looking up," not merely in the better provision which is being made for them, but in that more intelligent regard for a standard undivided and complete, so lately advocated in these columns.

CRYSTAL PALACE POULTRY SHOW.—H. S. Fraser, Esq., Headley, near Liphook, Hants, has sent us the following list

of subscriptions to the cup for Hondane at the great London Poultry Show:—

	£	s.	d.
The Committee of the London Poultry Show.....	2	0	0
Mrs. McAdam.....	0	10	0
The Rev. C. Rowland.....	0	2	6
The Rev. S. Milner.....	0	3	6
Mr. W. Massey.....	0	10	0
Mr. R. B. Wood.....	0	10	0
Mr. W. Dring.....	0	7	6
Mr. W. O. Quibell.....	0	5	0
Mr. H. S. Fraser.....	0	12	6
Total.....	£5	0	0

We are requested to state that the Committee, through the donations of a few amateurs per Mr. G. Saunders Sainsbury, are able to offer four prizes of £3, £1 10s., £1, and 10s for Black Ducks. Also, that exhibitors wishing to send their birds to other shows will be allowed to remove them after 6 P.M. on Saturday, December 10th; or they will be dispatched, if the proper labels are sent, on that evening; but in all cases a written request should be made to the Honorary Secretaries not later than Wednesday, December 7th.

INQUIRY.

I BEG to offer the following in explanation and defence:—In the first place I would remark, that there is something very strange and highly suspicious in any man advertising wares under a false name, and that George W. Pardon, shoemaker, Driffield, writing under the incognito of "J. Punshon," furnishes *prima facie* evidence that there must be something radically wrong. The object of the writer of this is not to recriminate or attempt to depreciate the much-vaunted 150 head of prize fowls of "J. Punshon," but "I will a plain unvarnished tale deliver," by giving the real facts of the case.

Attracted by an advertisement of 150 head of prize fowls for sale by a "J. Punshon, of Downe Street, Driffield," a gentleman took train to Driffield in quest of the said J. Punshon, of Downe Street, but after a long search no "J. Punshon" could be discovered; the object of search was voted a myth, the gentleman feeling very foolish and chagrined. "East Yorkshire," it appears, was about to leave by train, and casually entering into conversation with one of the railway porters, was recommended to apply to me as an extensive exhibitor. The gentleman came, or rather was brought to me, and I had the pleasure of selling him a pen of first-rate birds, and not "second-rate," as stated by J. Punshon. After the sale of the birds the gentleman naturally conversed on the subject, and most assuredly I mentioned the fact of J. Punshon's fowls being diseased, but not with the remotest intent of affecting J. Punshon's interest; indeed, the facts of the birds having been purchased and the gentleman being about to leave, showed there was no such animus.

In conclusion I would remark, that I can well afford to allow J. Punshon his bragat remarks relative to the number and quality of his fowls, and, perhaps, he will pardon something like the same principle in myself, when I remind him that during the last three seasons I have taken 450 prizes, and have sold single birds for as high as £3 10s. each.—GEORGE HOLMES, *Laura Cottages, Great Driffield.*

[Here this correspondence must cease from our columns.—Eds.]

RABBITS AT THE COMING YORK SHOW.

THE Committee are congratulated on the attractive prize list—viz., two five-guinea cups for five classes of Lops; one silver medal, value one guinea, for the "Variety classes"—viz., Angora, Himalayan, and Any other variety. The first five classes are for single Rabbits, the last three are for pairs. Entrance fee, 2s. in all classes. Prizes—20s. and 10s. classes 1 to 5; 15s. and 7s. 6d. classes 6 to 8.

I cannot think, with the above facts before me, that "CUNICULUS" can congratulate the Committee on offering such unfair terms to the latter three classes, well knowing the variety classes will be about two to one at the Show. I was canvassed to contribute towards the cups; I promised 10s. 6d., and pledged to enter eight pens (16s) in the "Variety class" not being a Lop-fancier, on condition that a cup should be given to "Variety classes," and single Rabbits to be a pen, not pairs. My offer was declined, and I was well enabled, and told to collect

for a cup in my own classes, as the cups were for Lops. Can the York Committee, by offering such terms, be dealing fairly with the Rabbit-fanciers? Eleven guineas are collected for cups and medal. I think the Committee ought to have made a common fund, and given three four-guinea cups, which would have been more satisfactory. I shall decline entering anything under the circumstances.—S. G. HUDSON.

The glowing account given by "CUNICULUS" of the above Show, would lead most people to believe that something extraordinary and above the average mark was offered; but now that the subject is fully broached, I have no hesitation in making a few remarks on the partial way in which the prizes, especially the cups, are offered. In the first place, there are five classes for Lop-eared—first prize, £1; second, 10s.; and two silver cups, valued at five-guineas each; entrance, 2s. per pen. Now we come to the ill-used fancy varieties, of which about six have to be content with only three classes, and the prizes as follows:—First, 15s.; second, 10s.; and silver medal for the best in the three classes; entrance, 2s. per pen—just the same as the Lops, to which three times the amount of prizes are given, and but for the generous donor of the medal I suppose we should have to be content with the money prizes alone. Above all other faults is having to show in pairs, which is a great drawback to all exhibitors, besides being very disgusting, and double the weight in carriage. Very often after a show of this kind, you find your finest Rabbit breeding, which spoils her for some time; it is of this that I am loudest in my complaints, and I am sure it is not too late for the Committee, if they think proper, to publish in "our Journal" that they have resolved to have only single Rabbits shown, instead of the pairs. I for one would make double the number of entries to what I should if the list remain as it is, as I do not wish to spoil my prize does for the rest of the coming shows. It is the greatest bar to the success of the York Show, and will keep back some choice specimens. I think if the Judge's name could be stated, we should know better what to send.—J. B.

SOUTHAMPTON POULTRY SHOW.

THIS Show, which opened on the 1st inst., consists of 848 pens of poultry, Pigeons, Canaries, British and foreign birds. It is a very good collection, and although the first was the half-crown day, it was thronged with high-class visitors. As a whole the condition of the birds is excellent. The prize Canaries are superb in colour. We shall publish a full report next week.

- SPANISH**—1 and Cup, best pen in Show, H. Yardley, Birmingham. 2, Nicholls and Howard. *hc.* J. E. Rodbar; H. Brown.
- DEPONS**—1 and Cup, J. Martin. 2, T. Bridon, *hc.* Viscount Tarnour; H. Lingwood; O. F. Cresswell; L. Patton; J. Lewry. *Chickens*—1, L. Patton. 2, J. Martin. *hc.* F. Parlett, Great Baddow; Viscount Tarnour; J. Smith; J. White; H. Lingwood; J. Martin; O. F. Cresswell; Mrs. Bain; L. Patton; L. Lewry; Countess of Aylesford. *c.* F. Parlett; J. Watts, Birmingham; H. Lingwood; J. L. Lowndes; Countess of Aylesford.
- COCHINS** (Any variety)—1, Herace Lingwood. 2 and 3, J. Cattell. *hc.* J. K. Fowler, Aylesbury; E. S. S. Woodgate; J. Stephens. *c.* W. Masland; Mrs. Allsopp; Churckley & Dove; A. Gibson.
- ORPINGTONS**—*Duck*—1 and 2, H. Lingwood. *hc.* and *c.* Hon. Miss D. Pennant. *Light*—1 and Cup and 2, H. M. Maynard. 3, H. Fowsett. *hc.* Mrs. T. Turner; H. M. Maynard; J. Pares; F. Crook. *Chickens*—1 and Cup and 2, Mrs. Williamson. 3, H. M. Maynard. *hc.* Mrs. T. Turner; A. O. Worthington; Rev. N. J. Bidley. *c.* H. M. Maynard; T. A. Dean; J. Pares; F. Crook.
- GAME**—*Black and other Reds*—1 and Cup, H. Gibson. 2, J. Laming. *hc.* J. Laming; H. C. Dear. *Chickens*. 1, J. Laming. 2, E. Bell. *hc.* J. Laming; S. Matthews. *c.* W. H. Strong. *Any Variety*—1, H. M. Julian (Duckwing). 2, J. Mason (Duckwing). *hc.* C. F. Mentor (File); G. S. Sainsbury (Duckwing); W. Barfoot (Duckwing).
- HAMBURGS**—*Silver and Gold-pencilled*—1 and *c.* F. Pittis, jun. 2, W. K. Tickner. *hc.* Duke of Sutherland, Trenham; Mrs. Pattison; N. Barter; H. Moore. *Silver and Gold-spangled*—1, Mrs. Pattison. 2, N. Barter. *hc.* Mrs. Pettat; Mrs. Allsopp; T. Walker, jun. *c.* Miss C. E. Palmer.
- POULTRY** (Any variety)—1, A. Crutenden. 2, J. Hinton. *hc.* H. Laver. *c.* W. Boothby.
- FRENCH FOWLS**—1, Hon. C. Fitzwilliam. 2, H. S. Fraser. *hc.* Mrs. Pattison; W. O. Quibell; J. K. Fowler; Rev. N. J. Bidley. *Chickens*—Cup and 1, Hon. C. Fitzwilliam. 2, J. J. Malden. *hc.* W. O. Quibell; W. Dring; Miss E. Williams; R. B. Wood; Mrs. Seamons. *c.* W. O. Quibell; Rev. J. H. Ward; W. Dring; Miss E. Williams.
- ANY OTHER VARIETY**—1, W. Walker, jun. (Black Hamburgs). 2, J. Hinton (Ducks) (Aylesbury). 3, W. Collyer (Black Hamburgs); W. B. Tegetmeier (White Leghorns); Rev. N. J. Bidley (Malays).
- BANTAMS**—*Game*—Cup and 1, H. C. Rogers. 2, J. C. & F. Nesbitt. *hc.* F. S. C. Gibson; T. W. Anns; W. B. Jeffries; C. F. Hore; C. J. Spry; G. Smith; W. Boucher; J. C. & E. Nesbitt. *c.* S. Samwasa; F. S. C. Gibson; T. W. Anns. *Any Variety*—1, M. Lenox. 2, E. Cambridge. *hc.* Mrs. Pettat; H. M. Maynard; H. Yardley; M. Lenox. *c.* Lady S. Tarnour; J. Watta; W. Masland; Mrs. E. Bull; Countess of Aylesford.
- DEPONS** (Aylesbury)—1 and 2, Mrs. M. Seamons. *hc.* J. J. Sivell; Miss Cresswell; J. K. Fowler, Aylesbury. *Any other Variety*—1, C. N. Baker (Mandarin). 2, G. Scott (Ronen). *hc.* F. G. Dalzelet (Paradise, bred in New Zealand). *hc.* S. & E. Ashton (Shell); S. Burn (East Indian); M. Leno (Mandarin); Mrs. M. Seamons (Ronen); J. Watts (Carolina). *c.* S. H. Stott (Ronen); M. Leno (Carolina); C. N. Baker (Carolina); F. Pittis, jun. (East Indian); T. C. Harrison; Mrs. H. Morant; L. Patton.
- C.** Mrs. M. Ford.
- TURKEYS**—1, L. Patton. 2, Rev. N. J. Bidley. *hc.* Mrs G. Withers; M. Kew. **SELLING CLASS**—*Cock or Cuckered*—1, Viscount Tarnour (Dorking). 2, Lady

Heathcote (Crève-Coeur). *hc*, R. J. Wright (Brahma); Viseount Turnour (Dorking); W. Birch (Cochin-China); H. Dowsett (Dorkings); c, L. D'Elboix (Brahma); G. S. Seimsbury (Game); H. Yardley; J. Glessall (Brahms); T. Briden (Dorking); Mrs. M. Seamons (Silkies). *Hens or Bulets*.—1, D. C. Campbell (Dorkings); 2, A. Gibson (Cochin). *hc*, S. Sminways (Game); Viscount Turnour (Dorkings); Mrs. N. Grenville (Houdans); Mrs. Ford (Brahmas); H. Dowsett (Dorkings); Miss Malcolin (Dorkings); Mrs. Seamons; Lady Heathcote; J. Lewry. c, C. B. Dixon (Game); Lady Heathcote. *PHREASANTS*.—1, Lady Heathcote. 2, J. K. Fowler. *hc*, E. S. C. Gibson (Gold-)

PIGEONS.

POUTERS.—1 and 2, R. Fulton, Deptford. *hc*, C. Bulpin, Bridgewater. *TUMBLERS*.—1, E. T. Dew. 2, J. Ford. *hc*, J. H. Vimery; R. Fulton. *BARRS*.—1, R. Fulton. 2, H. M. Maynard. *hc*, H. Yardley. *JACOBS*.—1, C. Bulpin. 2, G. Roper. *FACEDS*.—1, H. M. Maynard. 2, A. M. Yettis. *OWLS*.—1, P. H. Jones. 2, H. Yardley. *hc*, S. A. Wyllie. c, Rev. C. Lock; S. A. Wyllie. *TURBITS*.—1, P. H. Jones. 2, H. Yardley. *hc*, G. H. Gregory; E. J. Dew. *CARRIERS*.—1, H. Yardley. 2, R. Fulton. *hc*, R. Fulton; C. Bulpin. *TRUMPETERS*.—1, P. H. Jones. 2, H. L. Tvey. *NOBS*.—1, P. H. Jones. 2, H. Yardley. *hc*, H. Yardley; F. Graham (2). c, E. T. Dew. *DRAGONS*.—1, C. Bulpin. 2, F. Graham. *hc*, H. Yardley. c, J. Watts. *ANY OTHER VARIETY*.—1, H. Yardley. 2, J. Fletcher. *hc*, S. A. Wyllie. c, W. B. Tegetmeier (Icel). *SERLENO CLASS*.—1, T. B. C. Williams. 2, J. Watta. *hc*, P. H. Jones; H. Gibson. *The Silver Cup* for most points, H. Yardley. *JUDGES*.—*Poultry*: Mr. E. Hewitt, Birmingham. *Pigeons*: Mr. F. Esquilart, London.

[We have not received the prize list of the Canaries; we will publish it next week.—Eds.]

MIDDLESBROUGH BIRD SHOW.

The Middlesbrough and North Riding of Yorkshire Ornithological Association's attractive schedule brought together, on October 28th and 29th, 262 birds for competition—birds, too, of the highest quality—from very distant parts of England; Derbyshire, Northampton, and Bristol sending representatives. Although the birds from the latter place arrived, still they were not in time to be judged, the return having been given in before they could be unpacked and staged. This is much to be regretted. A telegram stating they were sent off was received, and judging delayed to the very latest hour in consequence. First, second, and third prizes, accompanied with a commendation, were awarded in each class, but a great many fine specimens had to put up with a blank.

The Belgians were excellent, those shown by Mr. Needler, of Hull, having many points: the Norwich, especially from Northampton, first-class; and the Lizards, Silvers in particular, Cinnamons, Crested, Yorkshire, Copy, and Goldfinch, Linnets, and Canary Males, all being in good condition for the fanciers' just appreciation. In many classes the competition was very severe, but every attention was paid in discriminating and summing-up these birds which took the highest honours. Mr. Hawman, of Middlesbrough, has reason to be proud of his Even-marked Yellow Norwich, the quality of which is good, and will tell well throughout the season. A better class of "Copy Crests," or "Manchester Copyss," than that shown is not often seen. Every bird deserved a prize. The Crested Norwich birds were indeed real crested specimens, being heavy and even, and well backed-up in quality and plumage. One exception may be here noticed, not with respect to its crest, which is all that could be wished for, but because it departs from Norwich form, partaking of too much the appearance of half-bred Copy. The Clear Green Canary class contained specimens, excepting in two or three instances, the reverse of green. The first-prize bird ran away from all others. In the British bird classes there were several beautiful specimens, conspicuous above others being Mr. J. N. Harrison's fine Brown Linnets, and Messrs. Fryer & McCune's Blackbird, besides many Goldfinches. The Linnets and Canary Males were extraordinarily good and very valuable. The following is the list of the prizetakers:—

BELGIANS.—*Clear Yellow*.—1, W. Needler, Hull. 2, J. N. Harrison, Belper. 3, J. Barrett, Thirsk. c, E. Robson, Middlesbrough. *Clear Buff*.—1, G. Tomlinson, Stockton. 2, J. Barrett. 3, J. N. Harrison. c, L. Belk, Dewsbury. *Ticked*.—1, P. H. Jones. 2, and c, W. Needler. 3, J. N. Harrison. *NORWICH*.—*Clear Yellow*.—1 and 2, Moore & Wynne, Northampton. 3, T. Irons, Northampton. c, R. Simpson, Whitby. *Clear Buff*.—1, 2, and 3, Moore and Wynne. c, R. Hawman, Middlesbrough. *Evenly-marked Yellow*.—1, R. Hawman. 2 and 3, Moore & Wynne. c, E. Mills, Sunderland. *Evenly-marked Buff*.—1, S. Tomes, Northampton. 2 and 3, Moore & Wynne. c, E. Mills. *Unevenly-marked Yellow*.—1 and 3, Moore & Wynne. 2, R. Hawman. c, R. Robson. *Unevenly-marked Buff*.—1 and 3, Moore & Wynne. 2, R. Hawman. c, J. Fawcett. *Crested*.—1, R. Hawman. 2, T. Irons. 3, Moore & Wynne. *COPY CHEST*.—1, Fairclough & Howe, Middlesbrough. 2, W. Hutton, Baildon. 3 and c, W. Cotton, Middlesbrough. *LIZARDS*.—*Golden-spangled*.—1 and 3, J. Taylor, Middlesbrough. 2, E. Mills, c, Stevens & Burton, Middlesbrough. *Silver-spangled*.—1, J. Baines, York. 2, R. Ritchie, Darlington. 3, Stevens & Burton. c, L. Belk. *Broken Cap*.—1, T. Ritchie. 2, J. Taylor. 3, Stevens & Burton. c, F. Armstrong, Belper. *CINNAMON*.—*Jonque*.—1, S. Tomes. 2, and 3, T. Irons. c, E. Mills. *Buff*.—1, T. Irons. 2, Moore & Wynne. 3, S. Tomes. c, G. Tomlinson, Stockton. *Variogated*.—1, S. Tomes. 2, P. Rawley, Bradford. 3, R. Hawman. c, Stevens & Burton. *YORKSHIRE*.—*Clear Yellow*.—1, L. Belk. 2, J. Vail, Middlesbrough. 3 and c, J. Rowlands. *Clear Buff*.—1, J. Fawcett. 2, W. Hutton. 3, R. Cooper, Middlesbrough. c, Fairclough & Howe. *Evenly-marked Yellow*.—1, J. Lees, Middlesbrough. 2, A. Webster, King's Hall. 3 and c, Stevens & Burton. *Evenly-marked Buff*.—1 and 3, Stevens & Burton. 2, J. Taylor. c, Tenniswood and Brown, Middlesbrough. *Unevenly-marked*.—1, L. Belk. 2, J. Fawcett. 3, Stevens & Burton. c, F. Armstrong, Broughton. *CLEAR GREEN*.—1, Stevens & Burton. 2, Tenniswood & Brown. 3, R. Robson. c, J. Baines. *GOLDFINCH MULE*.—*Evenly-marked*.—1 and 2, J. Robson, Morpeth. 3, W. Needler. c, R. Robson. *Unevenly-marked*.—1, Fairclough & Howe. 2, Stevens

and Burton. 3 and c, W. & C. Burniston, Middlesbrough. *Dark*.—1, Stevens and Burton. 2, W. Nichol, Middlesbrough. 3, Moore & Wynne. *BROWN LINNET MULE*.—1 and 3, C. Robinson. 2, J. Spence, Sunderland. *GOLDFINCH MOTTLED*.—1, W. Clarkson, York. 2 and c, Tenniswood and Brown. 3, Stevens & Burton. *BROWN LINNET MOTTLED*.—1, J. N. Harrison. 2, Fairclough & Howe. 3 and c, R. Robson. *ANY OTHER VARIETY OF BRITISH BIRD*.—1, Fryer & McCune. 2, A. Webster. 3, Fairclough & Howe. c, W. & C. Burniston. *Mr. G. J. Barnesby, of Derby, was the Judge.*

SHOW OF THE DERBY CANARY AND ORNITHOLOGICAL SOCIETY.

The thirteenth annual exhibition in connection with this Society took place in the Athenæum Room, on Saturday, October 22nd. The Show was the best that has been held, one of its features being the presence of a greater number of foreign birds than usual. Parrots, Love Birds, Australian Magpies, Black-throat Finches, Red Finch, Diamond Sparrows, Chestnut Finch, Zebra Finches, a live Opossum, a case of Iguana Lizards, cases of stuffed birds, an Australian Parrot, Linnæus Mule, Goldfinch Mule, a Thrush, &c., were exhibited, but not for prizes.

A subscription sterling silver cup was awarded to the winner of most prizes in six classes of Norwich birds—Mr. Barnesby had fourteen points, Mr. Henson and Mr. Woodward, Spondee, each gaining eleven points. Six extra special prizes were awarded to the first three winners in each class of the "Spotted or Cross-bred" birds, besides the money prizes of the Society. The winners were Messrs. Haynes, Henson, Barker, Woodward, and Coke. Two other special prizes were awarded, one being for the most prizes in several classes, and the other to the amateur exhibitor who took the greatest number of prizes; Messrs. Barnesby and Clarke being the winners. There were about 150 cages of Canaries and males shown for prizes.

Mr. T. Irons, of Northampton, and Mr. W. Matthews, of Nottingham, awarded the prizes as follows:—

CANARIES HATCHED IN 1870.

BELGIANS.—*Clear Yellow*.—1, R. Whiteacre. 2, J. Clarke. *Clear Buff*.—1, R. Whiteacre. *Ticked Yellow*.—1, G. J. Barnesby. 2, R. Whiteacre. 3, J. Clarke. *Ticked Buff*.—1, R. Whiteacre. *Variogated Yellow*.—1, G. J. Barnesby. *Variogated Buff*.—1, J. Clarke. 2, K. Whiteacre. *NORWICH*.—*Clear Yellow*.—1, R. Whiteacre. 2, F. Woodward. 3, G. J. Barnesby. 4, J. Smith. *Clear Buff*.—1, R. Whiteacre. 2, F. Woodward. 3, G. J. Barnesby. 4, J. Smith. *Marked Yellow*.—1, R. Henson. 2, G. J. Barnesby. 3, S. Smith. 4, F. Woodward. *hc*, S. Wall. *hc*, J. Clarke. *Marked Buff*.—1, P. Holland. 2, R. Henson. 3, G. J. Barnesby. 4, F. Woodward. *hc*, H. Hutchinson. *hc*, J. Tempest. *Variogated Yellow*.—1, R. Henson. 2, J. Clarke. 3, J. Tempest. 4, J. Winfield. *hc*, B. Reader. *hc*, G. J. Barnesby. *Variogated Buff*.—1, G. J. Barnesby. 2, J. Clarke. 3, F. Woodward. 4, B. Reader. *hc*, H. Hutchinson. *hc*, Mrs. Gadsby. *Crested Yellow*.—1, J. Barker. 2, J. Winfield. 3, G. J. Barnesby. *Crested Buff*.—1, J. Smith. 2, R. Whiteacre. 3, J. Winfield. *Green*.—*Yellow*.—1, G. J. Barnesby. *Buff*.—1, H. Hutchinson. 2, R. Henson. 3, J. Clarke. *LIZARD*.—*Golden-spangled*.—1, G. J. Barnesby. *Silver-spangled*.—1, G. J. Barnesby. 2, J. Clarke. 3, J. Barker. *CINNAMON*.—*Jonque*.—1, J. Smith. 2, E. Coke. *Mealy*.—1, J. Smith. 2, W. Hadley. *Marked Jonque*.—1, E. Coke. 2, T. Haynes. *Marked Mealy*.—1, J. Tempest. 2, W. Hadley. *SPOT OR CROSS-BRED*.—*Yellow*.—1, E. Coke. 2, J. Barker. 3, F. Woodward. *Buff*.—1, R. Henson. 2, E. Coke. 3, T. Haynes. *hc*, G. J. Barnesby. *MULES*.—*Goldfinch*.—*Jonque*.—1, G. Flinders. 2, G. J. Barnesby. *Mealy*.—1, H. Hutchinson. 2, G. J. Barnesby. 3, B. Reader. *Dark Mealy*.—1, G. Flinders. 2, G. J. Barnesby. 3, H. Hutchinson. *Brown Linnets*.—1, G. Flinders. 2, H. Hutchinson. 3, G. J. Barnesby. *Any other Variety*.—G. J. Barnesby.

ALL AGES.

BELGIANS.—1, R. Whiteacre. *NORWICH*.—*Clear Yellow*.—1, R. Henson. 2, R. Whiteacre. *Clear Buff*.—1, R. Whiteacre. 2, J. Tempest. *Ticked or Variogated Yellow*.—1, R. Henson. 2, P. Holland. *Ticked or Variogated Buff*.—1, J. Tempest. 2, R. Henson. *LIZARD*.—1, G. J. Barnesby. *ANY OTHER VARIETY*.—1, Mrs. Gadsby. 2, T. Barnes. *THURSK*.—J. Shinn.

PIGEONS ON THE NILE.—Mr. McGregor observes in noting the progress of his canoe on the Nile, "There is one of the Pigeon villages—it exists for Pigeons. A hundred mud towers, about 30 feet high, are clustered together, and myriads of blue and white Pigeons wheel in the air; sometimes passing these in my little vessel, one could see what I had remarked before on the Nile, that, when the banks are steep, and the Pigeons cannot well stand on them to drink, they settle on the water itself, and closing their wings and floating for a few seconds, they manage thus to slake their thirst."—(The Rob-Roy on the Jordan.)

ARE ABNORMALLY EARLY SWARMS DESIRABLE?

The great desideratum with many bee-keepers is to have swarms at the earliest period possible. To accomplish this object they have recourse to various devices. Some encase their hives with haybands, and others have stoves fitted up in their bee houses, but perhaps the plan most generally adopted is that of liberal feeding early in spring. These artifices, no doubt, sometimes succeed in bringing about the end desired, but cases are not wanting to show that on several occasions

they have signally failed, and no wonder; for if the season happens to be cold or wet, or both, the bees that have been prematurely sroused into a state of activity must necessarily go out of their habitation for an airing, and in consequence, great numbers, being unable to return, will perish. A bee coming from a greatly heated atmosphere into the open air, where the temperature is many degrees lower, is very easily chilled, and, if it should be able to find its way back to its dwelling, injurious results to it may follow from the sudden transitions through which it has passed.

Granting, however, that all goes on well, is it desirable to possess a swarm before what is considered the honey-gathering season has set in? If the flowers are few in number it cannot store up much food, or if they are washed much by cold rains it may not even prove self-supporting. Some people, as much distinguished for their ignorance of apian science as for anything else, boast of their superior husbandry when they happen to get a cast a few days or weeks earlier than their neighbours. They think it a great thing to have a swarm before the 1st of June, and that the old adage, irrespective of place and weather, holds good, "a swarm in May is worth a stack of hay;" but excepting on rare occasions, when seasons were unusually forward, I have never found very early swarms prove of much value. When summer is somewhat advanced they are apt to throw virgin swarms which do little good, and then in autumn, when the bee-master wishes to take their honey, he finds that a large proportion has been consumed by brood, and that the combs are anything but beautiful. These remarks apply chiefly to those who follow the system of their forefathers, and use only straw hives. But whatever be the material or form of hive employed, I do not think much benefit can accrue from the possession of too early casts. The date at which we should endeavour to have them cannot be fixed; this depends upon both the locality and the season, and it may happen to be either in May, June, or July.

For my part I never wish to see a swarm on the wing until the clover is coming into full flower, and the temperature rises to 62° or above it. In the district where I reside this happens to be generally about the end of June or beginning of July. The greatest produce during the last twenty years has been yielded by swarms that came off in July. Several of my neighbours this year had casts about the beginning of June, but the best of them had scarcely an ounce of honey stored up on the 15th of July. The weather was most unfavourable, and vast numbers of these tenants of empty houses perished from sheer starvation. With their numbers half diminished they began the labour of true honey-gathering on the 17th, but none of them prospered so well as swarms that did not emanate till about the 20th.

To prevent several of my stocks from swarming in June I gave them additional room, and supplied them with just as much food as was needed to save them from dying of hunger. When any young drones were ejected I knew it to be a signal of their supplies becoming exhausted, and forthwith they were furnished with from half a pound to a pound of either honey or syrup. When, therefore, summer proper and the honey season commenced, about the 17th of July, these stocks were all vigorous, and a few days afterwards were able to throw large swarms. These casts enjoying fine weather, and finding the fields covered with clover, filled their habitations completely in less than a month, and I need not add that their combs, only a small portion of them having been used for brood, presented a very attractive appearance. I do not, then, think that it is wise to have stocks more forward than the season, or to hasten swarming before the clover has come into flower and the weather promises to be favourable. It may be different in other localities. I speak only with reference to my own, where, on an average of years, it is sufficiently early to have swarms by the 20th of June.—R. S.

OUR LETTER BOX.

PLYMOUTH POULTRY SHOW—We were wrongly informed that Mr. Hewitt is to be the Judge at this Exhibition. He was applied to, but had a previous engagement.

WEIGHT OF LIGHT BRAHMA AND WHITE COCHIN PULLETS FOR EXHIBITION (Cheltenham)—You must have patience. Your pullets have not done growing because they have begun to lay. When this inflection, which many would pardon, is over, and its successor a little broodiness comes, your pullets will furnish and put on weight. Up to six months, if they are to be expected to take a prize, your chickens should weigh a pound for each month, Brahmas rather heavier than White Cochins. You will obtain weight by persevering. In all probability you already have the necessary scaffolding. Filling is easy work. Good ground oats mixed

with milk, table scraps, a little maize twice per week, an occasional lettuce, and any other gastronomic attention you can pay, will produce weight.

SILVER-SPANGLED HAMBURGERS' EARLOCKS (Idem).—We fear the red earlobe of the Silver-spangled Hamburga is hereditary. Good birds sometimes have the earlobe red during the moulting season, and some never have it white till they are twelve months old.

BREEDING PENCILLED HAMBURGERS (W. S. D. C.).—We believe you may safely breed from the cocks you name. Pencilled tails are always accompanied by pencilled hackles. Cock chickens are always pencilled when young, and as they lose the chicken feathers the pencilling disappears. To obtain the rich deep colour you want you must choose hens that are very much the colour of the shining top of gingerbread. These are always very heavily pencilled, and they will give you the colours you want in both sexes. It is almost impossible to breed exhibition cocks and pullets from the same parents. A good cock should not be light-coloured. His tail should be black, edged with rich bronze, but only edged. Never breed from a cock with a faint, washed-out hackle (we have seen them almost yellow), nor from mossy nor poorly-spangled hens. No amount of pedigree would induce us to breed from a defective bird.

DORKING CHICKENS WEAK-LEGGED (Constant Reader).—Your fowls have outgrown their strength, and their bodies are too heavy for their legs. That is why they rest on their knees. They are at the gawky age. They will never be better to eat than they are now if they are in good flesh, but often when they make so much growth they do not put on flesh. If they have flesh, you may either kill and eat them at once, or you may shut them up in a place where exercise is impossible, and feed them three times per day on ground oats and milk until they have fattened. There is nothing in the weakness to make them unfit for food, but we should not advise such for stock.

GAME BANTAMS NOT HATCHING TRUE TO COLOUR—COLOUR OF DUCKLING AND BROWN RED GAME BANTAMS (H. J. H.).—There can be no doubt the eggs have been mixed, or another cock has had access to the hen, or more likely still, the egg has thrown back to some other strain which has been used in making the birds. The description you give of the chicken is exactly that of a File. It is, therefore, likely some of that breed exists in your birds; you need not be surprised, as a strain will lie ignored for many years, and then suddenly show itself in force. The ordinary Duckwing's breast should be salmon-coloured, the hackles striped, and the back and body grey. The hen of a Brown Red should be nearly black with a golden-striped hackle. We should not pronounce hastily on the birds.

BLACK ROSE-COMBED BANTAMS WITH PALE COMBS (DeLa).—The combs will become redder as the season goes on and as the birds get older, provided they be kept in condition. It will be the same with the earlobes. Give them some cooked meat and some hard-boiled eggs chopped fine.

BRAHMS' LEGS DISEASED (T. F. A.).—The disorder of which you complain, and which has been called "poultry elephantiasis," is of recent introduction, and is, we believe, incurable. It does not of necessity belong to the Cochins, although they are most subject to it. If we owe it to them, it was many years in showing itself, and must be the result of interbreeding and consequent disease. We do not believe it to be hereditary. We have only succeeded in some instances in treating it successfully. It was in the early stage, and we kept the legs constantly moist with compound sulphur ointment. Lettices that have gone to seed are good food for fowls in this state. We have this disorder in Brahmas, Cochins, Crève-Coeurs, and Pheasants. It is very common for the centre toe of a Brahma cock to be crooked, and it is not very important that it should be scantily feathered. The feathering is on the leg, that is essential. Neither of the defects or shortcomings you mention should discourage you from exhibiting.

DORKING COCK'S FOOT SWELLED (Michael Dorking).—If the swelling on the cock's foot is hard enough to bear cutting, cut it by all means, but you should not make it bleed. Nothing is so difficult of cure as a sore on the foot of a Dorking cock, on account of the weight of the bird. We have known iodine beneficially used, but while it is applied the foot must be kept wrapped up. We should think the hen is kept too fat.

CHICKENS CROP-BOUND (F. T.).—There is no doubt of the healthiness of your chickens; they have grown up in spite of your feeding, and not because of it. We cannot imagine anything worse. Your fowls are suffering from being crop-bound. That generally arises from food. Flour (not meal) mixed close will clog a crop. Dry grass eaten from the lack of green meat will form a ball in the crop (like the "casting" of a deer), and in either case the bird will be crop-bound. The treatment of the disorder is twofold: First pour hot (not boiling) water down the throat and most gently manipulates the crop till the hard mass becomes soft and impressionable. Then continue the hot water till the crop is relieved, either by vomiting or otherwise emptying the crop. After the softening of the crop, give two table-spoonfuls of castor oil. When this has been taken, feed for some days on oatmeal mixed almost liquid, and ascertain by feeling that the crop is emptied after every meal. If this fails the only resource is to open the crop and take out the contents. It is an easy process. Pick off the feathers in a straight line down the breast, measuring from the head. With the thumb and finger squeeze the obnoxious body to the front till the bare skin protrudes, cut it straight with a lancet or sharp knife till the contents of the crop come out. Then have a very soft sponge and a glass syringe at hand, send some warm water down from the crop to the gizzard, and then with plenty of water thoroughly wash out the crop. To use your own words, it will "stink fearfully." When this part of the operation is over, take a stout needle threaded with coarse thread well covered with grease. Recollect you have to sew up the crop first, and afterwards the skin. If you get nervous or tired of the job you will probably sew-up skin and crop together, and the bird will die. To open the crop sufficiently will not require an opening of more than 2 inches in length. Five sutures will be sufficient; these should be thoroughly saturated with grease, and the lips of the wound should be brought close together. Then the skin should be sewed the same. The bird, fed during a week on gruel, and another week on slack meal, will at the end of a fortnight know nothing of the operation. Where such cases occur often the feeding is at fault.

GAME MOULTING WITH DIFFICULTY (A. H. H.).—There is something

WRONG IN YOUR FEEDING, or in the locality in which your fowls are kept. No fowl can moult with a heated body, as the feathers lack moisture; they itch, and the birds pick them out. We do not think linned good, as it has a tendency to make soft feathers. We advise you to feed on ground oats mixed with milk, a little chopped cooked meat, and now and then a little Indian corn, all preceded by purging with castor oil—dose, one table-spoonful.

HAMBROGH'S COMB AND LEGS SWOLLEN (M. M.).—Purge your birds freely, and use Bailey's pills.

BRAHMAS' COMBS (A. B. C.).—The single comb of a Brahma cock does not disqualify. The loss of an eye to a Spanish cock is a great disadvantage, but it does not disqualify.

FOWLS FOR AUTUMN AND WINTER LAYING (Hampshire Highlander).—Brahma Footras, Cochins, or Crève-Coeurs will suit you; the latter do not sit. Winter laying depends more on the age than the breed of the bird. Only pullets can be relied upon to lay during the winter.

EXHIBITING HENS (G. M. A.).—The feather is neither red nor inclining to red, and is quite unimportant. You may safely put your two hens together. Exhibiting hens of different ages in the same pen is commonly done, and is often necessary. It is not fair to show a hen and a pullet for two hens. There are but two classes, and they consist of hens and pullets. No one inquires, and very few can tell the age of the former.

ARTIFICIAL FOODS (C. E. M.).—We have so strong a conviction about these that we cannot insert any communications about them.

MANURE HEAP IN FOWL AND PIGEON ADOBE (Alpha).—We are not in the least surprised that your birds have died when they roost over a manure heap; nothing could be worse than an atmosphere charged with exhalations from decomposing matter. Carriers are, says Mr. Brent, "excellent breeders and nurses if not allowed to be too fat." They are, for high-class birds, strong and robust.

FOOD FOR DOVES (Vincent King).—Collared Turtle Doves, commonly called Ring Doves, are best fed on wheat, canary seed, and rarely hemp seed. In cooing, the cock's note is deep and mellow, and he swells his throat, then, rising and taking a step forward or after his mate, he repeats the same gesture and voice. The "Pigeon Book," by Brent, to be had from our office for twenty stamps, contains a good article on these birds, and the full particulars you require.

SICK POUTER (David Laurie).—We do not see that you can do anything more for your bird than what you are doing and intend to do.

WING DISEASE IN CARRIER (C. H. C.).—Dress the part with tincture of iodine; a druggist will tell you the strength of what you buy of him, and how often to use it, as the strength varies. The cause is scrofula. If the wing becomes stiff he will be useless to breed from, but in a hen it does not matter. Scrofulous birds are very apt to produce young like themselves, but it is not a contagious disease.

CARRIERS' EYES (Henry Cockton).—Try first a weak solution of alum and water applied twice a day; then, if that fails, a lotion of lunar caustic used carefully. If the trouble comes from the formation of spouts—that is, by the turning out of the lower lid, cut them off from below with a pair of very sharp scissors.

PIGEONS LEAVING THEIR COT (W. L. D.).—In or near their cot put some "salt-cat;" it is composed of about equal quantities of clay, such as brickmakers use; a coarse, gritty sand, or fine gravel, in which the grains are about the size of peas' heads; and old mortar: to this is added a small quantity of baysalt. Some persons, to make it more attractive, add aromatic seeds—such as cummin, anise, coriander, and caraway. The whole should be mixed up, with chamber-ley, into the consistency of mortar, and placed in a crock, the sides of which are perforated with many holes, large enough to admit the Pigeons' heads, and covered with a lid to keep off the weather.

PIGEONS (T. C. F.).—"The Pigeon Book," by Brent. It can be had free by post from our office if you enclose twenty postage stamps with your address.

PARROT, FEATHER-EATING (A. B. C.).—Feed on fruits and bread and milk, no meat, and give a shower bath of tepid water daily through the rose of a watering-pot.

FEEDING BEES (A Notice).—The best mode of feeding is by means of an inverted bottle, the mouth of which must be tied over with a bit of

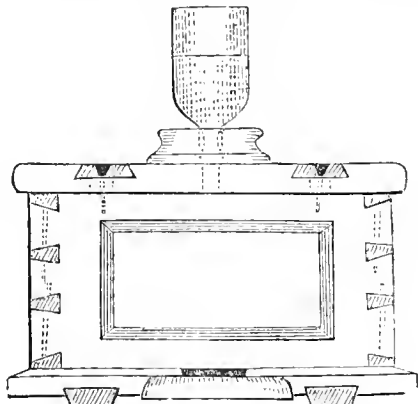

course lens or cap-net. With common hives the bottle-neck may be inserted in the central aperture, which usually exists (if not, one should be made with a sharp pen-knife) in the top, and refilled as often as may be necessary. With flat-topped hives the bottle should be supported by its neck being fitted into a perforated block of wood about 5 inches in diameter, and it will be found convenient to interpose a piece of perforated zinc, to prevent the bees escaping when the bottle is refilled.

BULLFINCH'S FOOT SWOLLEN (Lady C.).—Many cage birds are subject to diseases of the feet, arising, for the most part, from their perches, &c., not being kept scrupulously clean. In this case, however, cleanliness seems to have formed a prominent part of the régime, and the cause of the disease must be looked for elsewhere—possibly in the disordered state of the system consequent upon, or incident to, the struggle the bird has had in moulting. I can advise no better treatment than bathing the foot in warm water; and if the second swelling or gathering should assume the character of the first, prick it also, though I am adverse to performing surgical operations. Give a little hempeed.—W. A. BLAKSTON.

MULBERRIES, WHAT TO DO WITH THEM (Alice C.).—You can do as follows:—*To Preserve.*—Put the fruit into a preserving-pan, add draw from it, over the fire, a pint of juice. Take 3 lbs. of pound-d sugar, wet it with the juice, then boil it up, skim it, and put in 2 lbs. of ripe mulberries; let them stand in the syrup till warm through, and then set them on the fire to boil gently. When half done put them by in the syrup till next day, then boil them as before, and when the syrup is thick, and will stand in round drops on becoming cold, they may be put into pots for use. *Mulberry Pudding.*—Make a paste of 1 lb. of flour, 4 ozs. of beef suet chopped very fine, and hot water, with a little salt. Roll it out upon a board, then line with it a basin, which fill with very ripe mulberries; cover with paste, tie the whole tightly in a pudding cloth, plunge it in boiling water, and let it boil an hour or two according to its size. *Mulberry Wine.*—Take mulberries when they are just changed from their redness to shiny black; gather them on a dry day when the sun has taken off the dew, spread them thinly on a fine cloth on a floor or table for twenty-four hours, and boil up a gallon of water to each gallon of juice. Skim the water well, and add a little cinnamon slightly bruised. Put to every gallon 8 ozs. of white sugar candy finely beaten. Skim and strain the water when it is taken off and settled, put to it the juice of the mulberries, and to every gallon of the mixture put a pint of white or Rheims wine. Let the whole stand five or six days in a cask to settle, then draw off the wine, and keep it cool. This is a very rich cordial.

DAMP WALLS (A Cottage Gardener).—Paper them with waterproof paper before putting on the usual paper.

METEOROLOGICAL OBSERVATIONS

In the Suburbs of London for the week ending November 1st.

DATE.	BAROMETER.		THERMOMETER.				Wind.	Rain
	Max.	Min.	Air.		Earth.			
			Max.	Min.	1 ft.	2 ft.		
Wed... 23	29.513	29.380	59	36	50	49	S.W.	.00
Thurs.. 27	29.510	29.465	61	47	51	49	W.	.12
Fri... 28	29.892	29.649	56	49	53	50	N.W.	.01
Sat... 29	29.883	29.652	55	37	52	49	S.	.34
Sun... 30	29.824	29.804	60	47	51	49	W.	.28
Mon... 31	29.959	29.466	58	36	52	50	N.	.16
Tues... 1	30.369	30.235	56	24	52	50	N.	.00
Mean..	29.860	29.664	57.86	38.14	51.43	49.43	..	0.80

- 26.—Overcast; densely overcast; fine.
- 27.—Very fine; fog; clear and fine.
- 28.—Rain; cloudy but fine; densely overcast.
- 29.—Densely overcast; heavy rain; densely overcast.
- 30.—Clear and fine; very fine; densely overcast.
- 31.—Rain; heavy showers; clear and fine.
- 1.—Fine and clear; very fog; clear and frosty.

COVENT GARDEN MARKET.—NOVEMBER 2.

THE variation here is so trifling that our last report is but a reflex of the state of the markets this week.

FRUIT.

	a.	s.	d.		s.	d.	s.	d.
Apples.....	doz.	1 0	2 0	Mulberries.....	lb.	0 0	0 0	0 0
Apricots.....	doz.	0 0	0 0	Nectarines.....	doz.	0 0	0 0	0 0
Cherries.....	lb.	0 0	0 0	Oranges.....	doz.	29	0 0	0 0
Chestnuts.....	bushel	6 0	14 0	Peaches.....	doz.	4 0	12 0	0 0
Currants.....	sieve	0 0	0 0	Pears, kitchen.....	doz.	1 0	2 0	0 0
Black.....	doz.	0 0	0 0	Pears, dessert.....	doz.	1 0	3 0	0 0
Figs.....	doz.	2 0	3 0	Pine Apples.....	lb.	3 0	5 0	0 0
Filberts.....	lb.	1 0	2 0	Plums.....	sieve	1 6	3 0	0 0
Cobs.....	lb.	1 6	2 0	Quinces.....	doz.	1 0	0 0	0 0
Gooseberries.....	quart	0 0	0 0	Rasberries.....	lb.	0 0	0 0	0 0
Grapes, Hothouse.....	lb.	2 0	5 0	Strawberries.....	lb.	0 0	0 0	0 0
Lemons.....	doz.	10 0	16 0	Walnuts.....	bushel	10 0	18 0	0 0
Melons.....	each	1 0	4 0	do.....	doz.	10 0	2 0	0 0

VEGETABLES.

	s.	d.	s.	d.		s.	d.	s.	d.
Artichokes.....	doz.	0 0	0 0	0 0	Leeks.....	bunch	4	0	0 0
Asparagus.....	doz.	0 0	0 0	0 0	Lettuce.....	doz.	1	4	0 0
Beans, Kidney.....	sieve	3 0	4 0	Mushrooms.....	pottle	1 0	2 0	0 0	
Broad.....	bushel	0 0	0 0	Mustard & Cress.....	punnet	0 2	0 0	0 0	
Beet, Red.....	doz.	2 0	3 0	Onions.....	bushel	4 0	6 0	0 0	
Broccoli.....	bundle	0 9	1 6	pickling.....	quart	0 4	0 0	0 0	
Brussels Sprouts.....	sieve	3 0	4 0	Pursley.....	sieve	3 0	0 0	0 0	
Cabbage.....	doz.	1 0	2 0	Paranips.....	doz.	0 9	1 6	0 0	
Capsicums.....	doz.	1 0	1 6	Peas.....	quart	0 0	0 0	0 0	
Carrots.....	bunch	0 4	0 8	Potatoes.....	bushel	2 0	4 0	0 0	
Cauliflower.....	doz.	2 0	6 0	do.....	do.	8 0	4 6	0 0	
Celery.....	bundle	1 6	2 0	Radishes.....	doz. bunches	0 0	0 0	0 0	
Coleworts.....	doz. bunches	0 6	0 6	Rhubarb.....	bundle	0 0	0 0	0 0	
Cucumbers.....	each	0 6	1 0	Savoy.....	doz.	0 0	0 0	0 0	
pickling.....	doz.	2 0	4 0	Sea-kale.....	basket	0 0	0 0	0 0	
Endive.....	doz.	2 0	0 0	Shallots.....	lb.	6 0	0 0	0 0	
Fennel.....	bunch	0 8	0 0	Spinach.....	bushel	2 0	0 0	0 0	
Garbe.....	lb.	0 8	0 0	Tomatoes.....	bushel	1 0	1 0	0 0	
Herbs.....	bunch	0 8	0 0	Turnips.....	bunch	0 6	0 0	0 0	
Horseradish.....	bundle	3 0	6 0	Vegetable Marrows.....	doz.	2 0	8 0	0 0	

WEEKLY CALENDAR.

Day of Month	Day of Week	NOVEMBER 10—16, 1873.	Average Temperature near London.			Rain in last 43 years.	Sun Rises.		Sun Sets.		Moon Rises.		Moon Sets.		Moon's Age.	Clock at Sun.	Day of Year.	
			Day.	Night.	Mean.		Days.	m.	h.	m.	h.	m.	h.	m.				h.
10	Th		50.4	34.0	42.2	24	10	47	19	4	47	45	1	49	17	15	50	314
11	F	MARTINMAS.	50.2	34.2	42.2	15	12	7	17	4	22	6	3	19	18	15	50	315
12	S		50.2	33.8	42.0	17	14	7	16	4	7	7	1	11	19	15	43	316
13	SUN	22 SUNDAY AFTER TRINITY.	49.9	35.2	42.6	23	16	7	14	4	0	8	52	11	20	15	34	317
14	M		48.5	33.8	41.2	21	18	7	12	4	3	9	35	0	21	15	25	318
15	Tu	Stoke Newington Chrysanthemum Show	49.0	34.8	41.9	19	19	7	11	4	12	10	19	1	22	15	15	319
16	W	Royal Jersey Horticultural Show. (opens.	48.9	33.2	41.0	14	21	7	10	4	25	11	41	1	23	15	5	320

From observations taken near London during the last forty three years, the average day temperature of the week is 43.6, and its night temperature 34.1. The greatest heat was 63, on the 12th, 1841; and the lowest cold 18, on the 15th, 1865. The greatest fall of rain was 1.24 inch.

IN THE ROYAL FRUIT ROOMS.



RIGHT royally for many years have fruits been grown in Frogmore Gardens, and it is meet that it should be so. We look to Royalty herself as our ruler, our guide, and our example. We look to the Royal gardens and gardeners of Frogmore in like manner to show us much that is great and good, and all that is possible to be done in gardening. The sphere of gardeners at Frogmore is amongst fruits and vegetables—to supply the Royal household, and it is done well. To vegetables I will not here refer, further than to observe that in no other garden in England have I seen a more regal supply, and in such enormous quantities. There is vegetable-growing in earnest. But to the fruits.

I will here again pass by the long and noble ranges of vineries and pineries, with such Pines as Frogmore alone produces, which I will notice afterwards. I pass by the Peaches under glass and on walls, the Plums, Cherries, &c., and on to the Royal fruit rooms—to the Apples and Pears. Here, being joined by Mr. Powell, who has for many years so worthily had the charge of this department, first under Mr. Ingram, the founder of the gardens, now under Mr. Rose, his worthy successor, I was soon absorbed in a world of fruit. My visit was paid on the 26th of the past month, rather late in the season for many of the fine Pears; the glut of ripening Pears had just passed over, and a more steady succession was coming in. All were gathered, and here was the Royal supply for the months of the coming winter.

The fruit rooms at Frogmore are two in number. One is a large, lofty, square room at the back of the long range of vineries near to Mr. Rose's house, well fitted-up with shelves round the sides, and having a long centre table with drawers. The shelves are plain deal, on this paper is placed, and then the fruit. This is a very commodious, light, and airy room, better fitted for showing off the fruit than for keeping it; that being indeed the purpose for which it is principally used. Specimens of the different fruits are selected and placed here nicely ticketed and named for their Royal mistress to behold. I was told the Queen frequently has a peep at them, and it was pleasing to hear of the great and general interest she takes in all these little matters.

Fruit room No. 2 is a long, narrow, lean-to shed, I should say nearly 200 feet by 9 feet, with shelves on each side, and a pathway down the centre. There is nothing ornamental about this room, yet it is wonderfully well adapted, as has been proved, for keeping fruit. There is a door at one end and a small window at the other, whence all the light is derived. It is thus almost pitch dark in the centre at midday; to examine the fruits lamps are always wanted. Darkness is a very material point in regard to the preservation of fruit. The roof is thickly thatched with straw, the walls are thick, and the floor is thickly concreted, so that the room is at once dry and equable in temperature. Enormous quantities of Apples and Pears are stored in this

room, being placed on the shelves—the larger and finer in single layers, the others in heaps from 6 to 12 inches deep. I was struck by the general fine appearance of most of the sorts, which were pretty numerous, especially the Apples, but I was told they were smaller than usual, but richly coloured. Many of the Pears, the old standard sorts, were very fine. I missed, however, from amongst them many sterling sorts of more recent introduction, which I would suggest Mr. Rose should add to the Royal collection. I allude to such as Doyenne du Comice, Josephine de Malines, &c. These should be there in quantity.

Of the Pears which seemed to find most favour here, and which were to be seen in fine order, I may note Marie Louise, the last of which I was just in time to see; they having ripened much earlier than usual this season. We all know the good qualities of this Pear. Chantrelles were here, and are always wonderfully fine, much more round in shape, more hands-ome, and better-looking than when grown near London. There was here an immense quantity of Vicar of Winkfield with its peculiar twisted squinting look. It is very handsome without. This is of poor quality as an eating fruit, but is here found to be the best for stewing, so it is well worthy of cultivation for that purpose. Easter Beurre was here in grand style, and is usually tolerably good for late work. It is, however, considered inferior to Doyenne d'Alencon, a variety which in almost every fruit list is given as a synonym of Easter Beurre. As it is to be seen at Frogmore it is quite distinct. Single specimens of either could not be distinguished the one from the other, perhaps, but in the mass the characteristics are very striking. The flesh of Doyenne d'Alencon is yellow, whereas that of the Easter Beurre is white. Mr. Powell much prefers the former. Beurre Diel was also very fine. What a variable Pear this is! Here also were great shelves of Beurre de Rance, a first class late Pear but this season getting ripe now. Knight's Monarch did not look so well here as usual. This is one which has proved to be of the highest quality at Frogmore, yet is very seldom so elsewhere. It has an ugly habit of falling off the trees before being ripe, and shrivelling up afterwards. Mr. Powell, however, seems to understand its vagaries. Glou Moreau looked particularly well—great, clear yellow fellows—the type of a Beurre I should say. There were quantities of the large Duchesse d'Angouleme, the favourite Pear of the Paris markets, yet no particular favourite of mine. Winter Nelis was in great store, of the usual smallish character, invariably of fine quality. Of the old Swan's Egg, and its off-pring the Frogmore Swan's Egg, there were fine specimens, the latter being of a more rounded form, and fully sweeter than the former. Here also I ran across the old Maccas, a very good sort, and the Sabine, one of Mr. Knight's seedlings, but of no particular merit. Jean de Witte is likewise much approved of. It is like a small rich Glou Moreau. Here is another Pear very much condemned of late—viz., Prince Albert. At Frogmore this is by no means a bad variety. In appearance and quality it resembles the old Colmar. The most showy of all Pears, the Porelle, or Tront, was here in abundance. It is a pity it is not of a little better quality,

being only second-rate. Napoleon seems to be extensively grown, from the great stock of the fruit. What a wonderfully juicy Pear is this! and sometimes of very good quality. I noticed, besides, great quantities of that very ugly Pear Ne Plus Mennis, but a most excellent late spring variety.

To this already numerous list there are many other varieties to add, such as Fondante de Malines, a truly good, useful, little-known sort, very similar to Serrurier d'Automne; Reine d'Hiver, a highly-flavoured variety; Maréchal de la Cour, a splendid sort; the old Crasanne, a much overrated Pear; the Catillac and the huge Uvedale's St. Germain for stewing, of all of which there are remarkably fine examples to be seen. Many of these were grown on walls on fine old trees, models of careful training, chiefly on the fan system, which, in my opinion, is not so well adapted for the Pear as the horizontal. Others were grown on low arched trellises, others on pyramids and open standards. Nearly the whole of these trees in the gardens have been severely root-pruned by Mr. Rose since his advent amongst them, and with the most beneficial results. Trees which for years previously had produced but little fruit were last season, as I was informed, fully laden; the specimens, however, were not so large as from trees not root-pruned. The appearance of the whole of the trees, however, augurs well for an abundant crop next year.

Amongst Apples, although I was told they were unusually small, there were some remarkably fine examples. In general they were highly coloured and consequently very handsome. Blenheim Pippin was in great store. How this Apple varies from a great angular green fruit to a flat, regular, highly-coloured beauty almost resembling a Pear's Pippin! It is perfectly possible to select two Apples from the produce of a single tree so dissimilar in appearance as to defy Dr. Hogg himself to name them. Of King of the Pippins there were many bushels, and it is a very great favourite. This is another very variable Apple. Rosemary Russet was in fine order and in great quantity. This is one of Mr. Powell's favourites. "Give me," said Mr. Powell, "if I were a market gardener, of Apples Rosemary Russet, Scarlet Russet, and Cox's Pomona, and I would grow no other; they are all splendid varieties, and sure croppers." Cox's Pomona is one of the best large soft-fleshed Apples for dessert, and at Frogmore it is grown in quantity. Scarlet Russet is also beautiful and fine. Lord Naglan is rather a new sort, streaked, with a dash of Ribston Pippin flavour. Hampshire Golden Pippin is a good useful sort, and Gipsy King, a seedling, flat dessert Apple, somewhat like Sam Young. Court-Pendu-Plat was very splendid, and no better Apple exists in its season—January. Damsel's Seedling was unusually small. Of all the cooking Apples, perhaps this is the richest and best. Scarlet Nonpareils were very fine, and in great number, also the old Nonpareil; some specimens of this of such an enormous size and so totally different in character were shown me, that I positively refused to believe them to be true; others gathered from the same tree, however, had all the usual appearance. Never have I seen old Nonpareils so fine nor half the size. Frogmore Prolific was here also pointed out to me as one of the best autumn cooking Apples. This is a large sort, with fine white and tender flesh, raised at Frogmore. There are, besides, many other seedling Apples well worthy of cultivation. I observed a large quantity of Cockle Pippin, the favourite Apple of Sussex, and Dutch Mignonne, so justly esteemed for its good keeping qualities; also Golden Harvey, the richest and the best of all the small dessert sorts, and here the examples were good; Adams's Pearmain, than which there are few better; Cox's Orange Pippin, the most useful and prolific of all, and of the finest quality; Grenadier, a rather new, flat, scarlet-coated sort; Small's Admirable, a large and fine kitchen variety; and Small's Imperial, a large, streaked, pretty, highly-coloured sort, not so well known. Besides all these, there are many other fine varieties which I had not time to notice.

In conclusion, I would only add my mite of approbation of the general style of cultivation adopted here, and of the very efficient manner in which the Royal Gardens are conducted under Mr. Rose. I advise all who can to get a peep and judge for themselves. All such will there receive a Highland welcome.—ARCHAMBAUD.

PATERSON'S BOVINA POTATO.

In the spring I purchased 1 lb. of this remarkable Potato at 1s. 6d. per pound. These I cut into seventy-four sets, seven of which I parted with, and four failed to grow. I planted

them deeply, on the 30th of March, in loamy soil, heavily manuring it at the time with stable dung, giving a distance of a yard each way between the sets. When well up I drew a little earth round the roots; beyond this, and keeping the weeds down, they had no attention whatever. On November 2nd, on digging the crop, it was found to produce 7½ bushels, weighing 4 cwt. nett, of very large Potatoes. These facts may interest some of your readers.—ALFRED PEGLER, *Old Shirley, Southampton.*

P.S.—It is right to observe that not a drop of rain fell here during April, and in May we only had rain for two days, whilst in June we had but a couple of thunder showers. With a moderate degree of moisture I believe the crop would have been heavier.

GROUND LEVELLING AND PRACTICAL GARDEN PLOTTING.—No. 4.

DRAWING PLANS.

To Inscribe a Regular Polygon, in this case a pentagon, in a Given Circle.—Fig. 12 is thus described by Mr. Ellis A. Davidson in his work on linear drawing:—"Draw the diameter A B, and divide it into as many equal parts as the polygon is to have sides (in this case five). From a and b, with the radius A B, describe arcs cutting each other in c. From c draw a line, passing through the second division and cutting the circle in d. Draw d b, which will be one side of the polygon, set off the length d b around the circle—viz., e f g, join these points, and thus complete the figure. Any polygon may be thus formed by dividing the diameter into the number of parts corresponding with the sides of the required polygon, but the line c d must in every case be drawn through the second division."

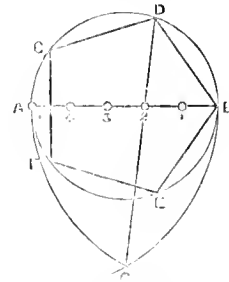

Fig. 12.

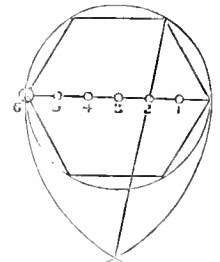

Fig. 13.

I have adopted this method in preference to any other, because I think it is easiest understood, and can be applied in the formation of any polygon.

- Polygon, a figure of more than four sides.
- Pentagon, a figure of five sides.
- Hexagon, a figure of six sides (Fig. 13).
- Heptagon, a figure of seven sides.
- Octagon, a figure of eight sides.
- Nonagon, a figure of nine sides.
- Decagon, a figure of ten sides.

For a bed it is not advisable to have a figure of more than eight sides, as such would approach the circle so nearly that it is better to have a circle instead.

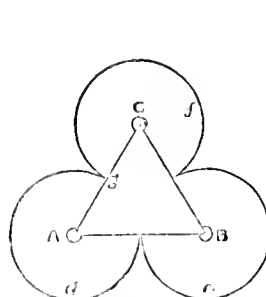

Fig. 14.

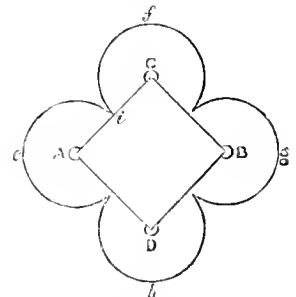

Fig. 15.

Fig. 14.—To Construct an Equilateral Triangle, A B C.—From A B C, with radius A g, equal to half the side of the triangle, describe arcs d e f.

Fig. 15.—To Construct a Square, A B C D.—With the radius A i, which is half the side of the square, draw arcs e, f, g, h.

Fig. 16.—To Construct the Pentagon, *A B C D E*, as described in fig. 12.—With the radius *Ab*, which is half the side of the pentagon, draw arcs *f, g, h, i, k*.

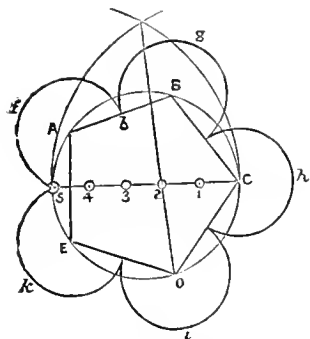

Fig. 16.

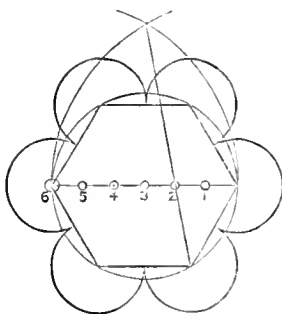

Fig. 17.

Fig. 17 is an application of fig. 13, in the same way as fig. 16 is an application of fig. 12.

A Hexagon may be formed by describing a circle, and applying the radius of the circle six times to the circumference, which will give the sides of the hexagon as nearly as need be.—M. O'DONNELL, Gardener to E. Leeming, Esq., Spring Grove, Richmond.

WINTER-BLOOMING ORCHIDS.—No. 10.

CALANTHE.

THE section of this genus which I here introduce consists of deciduous plants, producing their charming flowers during the winter months. They have been established as a distinct genus (*Prepanthe*), by Professor Reichenbach, a course which I consider correct, and which I adopt myself, but in consequence of very few Orchid growers in this country having adopted it, I have in this place retained the original name. These plants are very ornamental, and as they easily form good specimens and are very reasonable in price, they should be largely grown for winter decoration by everyone having a stove. The objection made to them by some is their deciduous character, and it is still the fact of the flowers being produced when the plants are leafless robs them of half their beauty, which is undeniably an objection, but still one that may be easily remedied by grouping them with such plants as *Dracæas*, *Crotons*, and *Ferns*. Besides the cheerful appearance the flowers of these plants produce during the dull months in the plant house, they are also extremely valuable for cutting either the entire spike for placing in vases in the drawing-room, or the single flowers for bouquet-making. To produce good flowering plants they should be potted in sound fibrous peat, leaf mould, well-decomposed cow manure, and sand in about equal proportions. The pots, be it remembered, should have been previously well drained. This operation should take place about the beginning of March, or earlier if the least sign of growth appears, for as these plants lose roots as well as leaves every season, the old soil will require taking away every spring; hence the necessity of putting them into new soil before the fresh roots start into the worn-out compost of the previous season. During the growing season water liberally, and I have always been most successful with them when I continued giving moderate supplies after the leaves had fallen until the flowering season was over, after which they should be kept quite dry for some time. Some growers of these plants fall into the error of drying them as soon as the leaves begin to decay, a system, however, which I have found very detrimental to the flowers. These *Calanthes* should not be grown in the East Indian house, but amongst the *Cattleyas* or *Odon-toglossums*; when grown in strong heat they are very liable to disease both in the leaves and pseudo-bulbs.

C. VESTITA.—Pseudo-bulbs broadly ovate and obtuse, and silvery grey in colour. The leaves are borne on the apex, and are from 1 to 2 feet in length, membranous, plaited, and broadly lanceolate, tapering to a point. The scape rises from the base of the pseudo-bulb, growing erect for half its length, and then becoming pendulous and producing a profusion of flowers, which continue in full beauty for several months. The sepals and petals are about the same size, spreading, broadly-lanceolate, and sharp-pointed. The lip is spreading, deeply

three-cleft, with a spur at the base, middle lobe cuneated; the lateral ones oblong obtuse. The whole flower is of a pure white, in some forms the sepals and petals are creamy instead of pure white. Native of Burmah.

C. vestita rubro-oculata.—This resembles the preceding in habit of growth, but is, perhaps, somewhat more robust. The flowers are more showy in consequence of their having a large, rich, crimson blotch at the base of the lip. Native of Burmah.

C. vestita flavo-oculata.—An exact counterpart of the previous variety in general appearance, except in regard to the flowers, which are stained at the base of the lip with orange yellow instead of crimson, which produces a beautiful contrast. Native of Burmah.

C. vestita Turnerii.—This is a distinct variety, but I am quite ignorant of its origin. It blooms later than the other forms, and the base of the lip or eye is deep rose colour.

C. VETCHII.—A most lovely winter-blooming plant, for which we have to thank Mr. Dominy, it being one of his hybrids. It is the result of a cross between *Limatodes rosea* and *Calanthe vestita rubro-oculata*. The pseudo-bulbs taper more to a neck than any of the *Calanthes*, and in this respect it resembles *Limatodes*. It is deciduous, and produces long, half-pendulous spikes of rich rose-coloured flowers, with a white eye. The shape of these blooms is longer than in any of the other kinds. It is a superb plant, and one which should be absent from no collection however small.

LIMATODES.

This genus is nearly allied to *Calanthe*, the principal points of distinction being a lip quite detached from the column, not united with it, and in the much longer column. The same treatment as recommended for *Calanthe* also suits this admirably.

L. ROSEA.—The pseudo-bulbs of this plant are fusiform, contracted about the middle, with a narrow neck. The leaves are produced from the apex, and are oblong-lanceolate, smooth, and plaited. Scape erect and proceeding from the base of the pseudo-bulb. Flowers pink or rose saving at the base of the lip, and there they are white; lip larger than the sepals and petals, oblong, flat, and retuse; spur straight and blunt. This very handsome species blooms during midwinter, and continues long in full beauty. Native of Moulmein.

L. rosea vestalis.—A variety of the above, producing pure white flowers. It is very elegant, and a charming contrast to the various shades of rose and pink of the species. Native of Moulmein.

EPIDENDRUM.

As regards this extensive genus I purpose confining my remarks to two species only, and they both well deserve general attention for the ease with which they may be grown, the cool treatment under which they thrive, and the rich and rare colour of their flowers, which are produced during midwinter, and last such a long time in full beauty if ordinary care be taken to keep them from being wetted. There are many other species of *Epidendrum* which bloom at this particular season, but the majority of them are small and unattractive, and, therefore, it is only reasonable that amateurs and gardeners, especially those with limited space, should prefer the most attractive kinds, or those yielding the greatest number of charms.

E. VITELINUM.—The pseudo-bulbs of this elegant species are ovate acuminate, and bear two leaves, which are oblong and acute. The many-flowered raceme is produced from the apex of the bulb and from between the leaves; sepals and petals ovate-lanceolate, acute, and rich orange scarlet in colour. The lip is linear, narrowed below, becoming suddenly acute and bright yellow. This plant is a native of Oalaca, where it grows at elevations of some 3000 feet above the sea level. This fact being known, it is natural to infer that the plant succeeds only in cool places. I have had the greatest success with it treated as a block-plant, using a little moss for the roots to penetrate, by keeping it in the coolest place I could find in the *Odon-toglossum* house, and by never at any season depriving it entirely of water. I have seen a plant in various collections called *E. vitelinum*, but which has caused much disappointment to the possessors when in flower. It is *E. virgatum*, which very much resembles the former plant, but the leaves are more glaucous, and it produces a long spike of small, dirty greenish-brown flowers.

E. HAGUENSE.—The thin stem-like pseudo-bulbs of this plant are furnished with oblong, obtuse, fleshy dark green leaves. The flowers are produced in a terminal cluster, and are orange-scarlet in colour. It is easily grown, dwarf in habit, and an abundant bloomer, qualities which should recommend

it to all. E. ibaguense is a plant of somewhat recent introduction, and may be grown either upon a block or in a pot. If the latter method be adopted drain well, and use sphagnum moss and peat in equal parts, with some pieces of charcoal intermixed. It requires cool treatment; indeed, it thrives admirably in a temperature of from 35° to 40° in winter. It is found about Loxa, also at Ibaguë, growing at elevations of 4000 feet and upwards.—EXPERTO CREDO.

TRIAL OF PEAS AT SEAHAM HALL GARDENS, SUNDERLAND.

All the varieties were sown on February 23rd, 1870.

Name.	Height in feet.	When in flower.	Ready.	Crop.	Average no. of Peas in a pod.
No Plus Ultra (1)	7	June 16	July 8	good	6-8
Harrison's Glory	3	May 27	" 4	"	6
Unimproved Green Mammoth	4-5	June 12	" 6	"	6
Dwarf Sugarloaf	2	" 2	June 28	"	4-5
Paris 10	2	" 15	July 9	good	4-6
Veitch's Perfection (2)	3-5	" 15	" 4	very good	5-6
Blue Schmeiter (3)	3-4	" 15	" 9	good	5-6
Prize-taker	4	" 15	" 4	"	6-8
Champion of England	4	" 10	June 30	"	4-5
Dickson's First and Best (4)	3	May 23	" 18	"	5-6
Luxton's Supreme (5)	5	June 12	July 1	very good	8-9
Tom Thumbs	1-2	" 2	" 1	good	5
McLennan's Double	2	" 12	June 30	"	5-6
Nonpareil	4	" 13	July 2	good	6
Lamb's Profit	5	" 12	" 4	"	6-9
Advancer	2	" 10	June 30	"	8
Emerald Queen	4-7	" 12	July 2	"	6-9
Waterloo	2-3	" 16	" 9	"	6-7
Dwarf Mammoth (6)	2-3	" 16	" 8	"	4
Little Gem (7)	1-1 1/2	May 21	June 16	very good	5
Premier (8)	5	June 16	July 12	good	6-8
Professor Royal (9)	3-4	" 13	" 9	very good	6-8
Arrow-point	5	" 13	" 8	good	6
Wonderful	4-6	" 15	" 8	"	6-8
Eley's Essex rival	4	" 4	" 6	"	4-6
Tabor's Collection (10)	3	May 31	June 25	"	5-6
Sutton's King-ender (11)	3	" 21	" 18	"	5-6
Dickson's Favourite	4	June 11	July 1	"	7
Bishop's Lion-pod	2	May 30	" 4	"	6
Paradise Marrow	4 1/2	June 14	" 4	"	6
Sutton's Early Champion (12)	3	May 25	June 18	"	5-6
Surprise	5	June 12	July 8	"	4-7
Nelson's Vanguard	2 1/2	May 27	June 30	"	4-6
Hoppe's Gold (13)	4	June 9	" 30	"	6-8
Sanger's No. 1	5 1/2	May 26	" 26	"	5-6
Emerald	5	" 30	July 2	"	5
Multum-in-Parvo (14)	1-1 1/2	June 10	June 27	very good	6
Epitaph	1-2	" 19	" 30	"	6
Prince	5	" 10	July 8	good	6-7
King-of-Tall Marrow	6	" 16	" 9	"	6-7

REMARKS.

- 1.—Good for general crops.
- 2.—Good for general use; fine flavour.
- 3.—This Pea is the best of all the varieties to grow in dry weather, for after all the other kinds were ripe this kept green.
- 4.—One of the earliest varieties, and best.
- 5.—Quite a distinct variety; foliage light green; the pods are large, but well filled. I think in a favourable season it will be the best Pea out.
- 6.—Straw strong, and a good cropper.
- 7.—Best for early use, requires no stakes, and good flavour.
- 8.—One of the best for general use.
- 9.—A first-class variety; distinct and broad pods.
- 10.—A very good useful Pea.
- 11.—Much the same as Dickson's First and Best. A very useful variety.
- 12.—Much the same as Dickson's and Vanguard.
- 13.—A first-class Pea, worth a place. The pods are of a dark green.
- 14.—A very nice useful kind.

The seed was principally supplied by Messrs. Veitch & Sons, and I found it very good and true to name. I had the assistance of several gardeners to judge, and those remarked upon were thought superior to the others.—R. DRAPER.

WITNESSES.

(Continued from page 206)

Sown only in importance to draining is trenching, for the ground is free from weeds and its fertility is in a great measure dependent on the latter operation. It is quite as necessary for the ground as for that which has been some time under crop. For vegetables, fruits, and flowers, for shrubs and trees, the ground should be trenched—1st, Because it at least doubles

the depth of soil which can be easily penetrated by their roots, and consequently renders available for the plants' support a much larger amount of nourishment than would otherwise be the case; 2nd, It gives a free passage to rain, the decomposing matters in the soil are more equably distributed, and it admits air; 3rd, As the roots penetrate to a great depth before hot dry weather sets in, the plants in trenched ground withstand the drought and heat of summer much better than those in ground only surface-dug; 4th, It destroys weeds, especially those of annual or biennial duration, and, indeed, there are but few weeds that it will not kill. Exception must, however, be made of Thistles, Couch Grass, Bindweed, Dock, and a few others. The weeds being trenched down, instead of impoverishing the soil, contribute to its fertility.

Not only new ground is the better of trenching, but also that which has been several years under crop. The vegetable matter in the surface soil, owing to frequent manuring and the decay of the roots of weeds, and of the plants forming the crops, is considerably augmented every year, and this acts as a great stimulant to growth whilst the plants are young and their roots near the surface, but when the roots have passed down some depth the growth is weak, and unless watering be resorted to the produce is not equal to that of the plants in a young state. Another reason for trenching is, that in many cases the surface soil is little else than a mass of decayed and decaying vegetable matter. Little but leaves is produced, and though these are all we desire in the case of Spinach and some other crops, we require very different results when the produce we seek is the pod, the root, or the head. This excessive vigour of top causes the plants to be tender, and the growths are incapable of resisting extremes of heat and cold. What, then? Is poor soil best? By no means; but it is possible to present the food in such a manner that, whilst it gives early vigour, it will in the end prove injurious to the health and productiveness of the plants. The advantage of all digging consists in rendering the soil more open, and intermixing its parts. But how can this be effected when the soil is merely turned over? The surface is, no doubt, made all that could be wished for, but what of the soil lower down than 9 inches from the surface? There we have a solid mass not easily penetrated by the roots, and it receives none of the enriching matter given at the top, except that reaching it in a soluble state, and its constituents are principally inorganic matter.

Surface-digging, whilst it tends to make the soil for a few inches deep a mass of vegetable matter, is apt to cause disease in plants by producing that gross unhealthy development which is often attacked by the worst forms of disease, such as rust, mildew, &c. The richness of the surface often serves to encourage insect pests, which for their existence require soil long worked, or, in other words, full of decaying and decayed vegetable substances. It is well known to all cultivators that plants in old soil are more subject to the attacks of some kinds of grubs, or the larvæ of insects, beetles, &c., than those in fresh soil.

The action, then, of trenching, is threefold: it brings to the surface inorganic matter, it buries the seeds of weeds to such a depth that they will not germinate, and it destroys the larvæ of many insects injurious to plant life, or prevents their increase.

Some persons consider that whatever manure is applied should be given at the surface, and think that to bury it at a greater depth than a foot is to place it beyond the reach of the plants. This is a great absurdity, for plants, as a rule, root deeply; but in cultivation they do not so root, because their food is given on the surface, and the roots cannot descend if they would. We know that when plants have an opportunity they do root deeply, and are often difficult to restrain. Fruit trees exhibit this tendency, yet no one thinks of planting them without giving them a good depth of soil by trenching, or making borders of considerable depth, being at great labour to remove the bad soil, &c. Strange that persons doing this should advocate manuring on the surface! They tell us it keeps the roots there, which is also an error, for the roots go down, up, and sideways, wherever their food is and the way open. But if we do not keep the roots of Peas on the Quince stock, Apples on the Paradise stock, and of all bush fruit near the surface, they will be unfruitful from the roots going down. If there are no roots near the surface, there are none of any consequence anywhere, for the stocks are surface-rooting, and supplying them with food on the surface is simply feeding them in the only available place; but even that is of no avail, unless the roots in part have a depth of soil to draw their supplies

from in dry, hot weather. Either they must have a good depth of soil, or the application of water must be copious and frequent in a dry season.

Others, again, advocate deep digging, and putting the manure down. This method, too, is an error, for the ground being naturally of a deep, moist nature, the roots are attracted downwards by the looseness of the soil, and the results are sappy unfruitful growths. A good depth of soil would never do any harm if it were free from stagnant water. What, then, is the good of manure if it be erroneous to put it on the surface, and also to put it at the bottom of the trench? Placed on the surface and buried at the bottom of a trench it is all in a mass. The roots must turn upwards to get at the manure on the surface, or be satisfied with what is washed down to them by the rains, deriving no benefit whatever from the volatile substances ever vanishing in the air. Surface-manuring is well for fruit trees; in no other way can manure be applied without injury to the roots. On the other hand, placing manure at the bottom of a trench only feeds the roots that invariably find their way down to it, and this mode of applying manure is consequently adopted for subjects that remain long on the ground, as Strawberries and fruit trees generally, for unless the manure be given in the first instance, or prior to planting, it is impracticable to do so afterwards. Sometimes the manure is put at the bottom of the trench when the ground is intended for Carrots, Parsnips, and other roots, for it has been found that a rich surface soil causes the roots to branch or fork; and for Lettuce, Cauliflower, and other plants likely to suffer from drought, the same mode of application is advised, in order to give them increased moisture and support when they are beginning to head, and to keep them from running. Except for certain crops, I hold that all manure should be dug in and mixed throughout the whole depth of soil.

The operation of trenching is so well understood that I need not describe it, but a few remarks may not be without interest. If the ground is fresh land that has been in pasture, or been used for agricultural crops, we have to take out a trench. The top spit of a space about 2 feet 6 inches wide we take out and lay where we intend to finish. The top spit will be good soil in almost all cases, and we need not trouble further about that, but the next spit may be partly gravel, clay, or other material of no value on the surface. In this case we remove no more of the second spit than is of a nature likely to yield to the influence of the atmosphere—not gravel nor hard close clay. Instead of bringing such up it is better to loosen it with a pick, and give a dressing of fresh manure; indeed, I cannot perceive any advantage in placing very rotten manure at the bottom of trenches. If grass, we pare off the top about 2 inches thick, and place it at the bottom of the trench, and then take out the soil below that and place it on the top. The bottom is then picked up, and it is ready for the manure and the soil of the next trench. This is for a very poor soil, and one that will need manure at top, bottom, and in every way that is possible to apply it to keep it at all fertile. Very few soils are of this description; generally two, and in many cases three good spades' depths can be had. In any case the soil of the first trench or opening should be taken out until we come to sand, clay, or gravel; the former and latter it is useless to bring to the surface, and not more than 2 or 3 inches of the clay should be brought up at one time, and the same remark applies to any soil inclining to be more sandy, clayey, or gravelly than is suitable for plant-growth and forming a good tilth for sowing or planting. The bottom, whatever it may be, should be loosened fully a spade deep, and if there are two good spits of soil, there will be no necessity to manure the bottom if turf or the top spit of ground that has been under crop be turned over it. Between the second spit and the first it would be well to give a moderate quantity of manure, and in all cases I should give whatever manure is wanted at a spit's depth from the surface. This is all that need be done; only, if the soil be heavy it is well to throw it up in ridges, so that the frost may act upon it, and in February or March it may be levelled, or in any case it should be forked over before it is planted or sown. If the soil is poor it is desirable to give a liberal dressing of manure prior to the forking over early in spring. Indeed, some loams are so poor when the soil from a good depth is brought up, that without some stimulant to growth the plants put in take very indifferently, and do not advance much in growth. The manure in this case should be short.

In trenching, whatever weeds may be on the surface, take no notice of them, but place them at the bottom of each trench. November is the best month to trench, for then the bottom soil

is ameliorated by frost and exposure to the air, and becomes workable by the time of putting in the crops. All garden ground should be trenched every third year, and whenever it is very weedy turn the surface fully two spits under.—G. ANONY.

PEAS AND POTATOES IN 1870.

READING IN YOUR last number notices on Peas and Potatoes grown in 1870, I thought the following particulars might not be uninteresting to your readers.

Peas.—I sowed Daniel O'Rourke on November 29th, 1869, and gathered the first dish on May 28th, 1870. From Carter's Surprise, sown on February 23rd, I gathered on June 20th; from Premier Marrow, sown on March 10th, I gathered on the 24th of June.

Potatoes.—I planted Election Kidney on December 24th, 1869, and gathered the first dish May 28th, 1870. Sutton's Racehorse I planted February 23rd, and gathered on May 28th. Mona's Pride was planted March 12th, and the whole crop was gathered July 30th.

I had a continuous supply from the days on which the first Peas and Potatoes were gathered. The crops were all grown in the open ground without any extra attention or protection.—M., Ross, Herefordshire.

TOMATOES.

HAVING had good success in the culture of Tomatoes out of doors, I send a few notes, with the distinguished names of several varieties suitable for outdoor culture.

So much has been written on the subject by different able practical men, that it is almost impossible to say anything new; still, knowing the usefulness of the Tomato in both large and small families, how eagerly it is inquired for in the kitchen, and how much superior in quality home-grown Tomatoes are to those purchased in the market, I wish to point out that anyone with a warm border, or a south or south-west wall, need never despair of success.

In the first week of March the seed should be sown thinly in a 6-inch pot well drained, using about one-half fine leaf mould, and the remaining half loam, with a sprinkling of sand, and place it in a vinery or greenhouse. As soon as the seedlings can be handled, prick them out 3 inches apart in a pan filled with a light rich compost, consisting of fibrous loam to support the fine leaf mould one part, and the remainder old rotted manure mixed with sand. I place them to have plenty of fine leaf mould in the earlier stages of their growth, which encourages their young delicate roots.

In a fortnight after pricking out they should be ready for potting in 3-inch pots, using more loam and giving them plenty of drainage in this as in all their sittings. As soon as they get established give them plenty of air to keep them from becoming drawn, stake them with small sticks, and tie them loosely. Particular attention must be paid to tying them, as they are of very quick growth, and the ties soon out the stems, which are then liable to snap off just when the plants should be at their best. Immediately the roots reach the sides of the pot's report in 6-inch pots, using the same composition as before, the leaf mould may now be a little coarser—say half-inch. Reporting directly the roots reach the sides of the pots, till the plants are placed in their fruiting pots, is one of the points to be attended to, as helping to keep them clean, healthy, and steady in growth. I report when the plants are ready, in 9-inch pots, and lastly, in 12-inch pots, using a coarser soil this time, and placing a few inch bones above the crocks.

I have the plants hardened-off for turning out in the summer's quarters by the third week of May. I should be glad that I have had good fruit of plants potted from the seed-pots in 6-inch or 9-inch pots, though I prefer those treated in the way I have described. Abundance of water should be given both to the root and top, never, if possible, allowing them to flag from want of it. Should they, before they are planted in their final quarters, show any trace of green fly, give them a syringing of water in which soft soap has been dissolved at the rate of 2 ozs. to the gallon, turning the plants on their sides. In fact, to make doubly sure I syringe them clean or unclean, as I believe the soft soap is very distasteful to insect life.

The plants being now ready for planting, they should be plunged at once in the border, giving them additional stakes for support, using one or more according to the style of training and the room there may be. I have used only one

stake a yard high, tying the plant to it as required, and pinching the shoots one joint above the flowers. I have also used one stake in the centre of the pot, and one on each side in the border, at 9 inches apart or more as convenient. This is a good way of training them, but the best plan of all when it can be done is to nail them to the wall, plunging the pots when convenient; but sometimes when I have had open spaces between the fruit trees on the walls, I have trained the plants over these, but I could not plunge the pots more than a few inches owing to the roots of the trees. When grown on a wall particular attention should be paid to the thinning of the shoots and nailing-in, and where there is room they can be made to cover a great space and will look very effective.

I seldom find manure water required till the fruit is swelling-off, but should rich compost not be at hand, watering with liquid manure is very beneficial. Where fine fruit are required rather than quantity, they should be thinned as soon as set, leaving one, two, or more fruit on a cluster as required.

I will enumerate the kinds suitable for out-door culture here. The first on the list and the best is General Grant. This is the finest Tomato I have cultivated or seen, single fruit weighing from 4 to 8 ozs., and to these weights I have grown from twelve to twenty fruit on a plant. It is not the earliest kind, though I gathered in the first week in August, and the fruit ripened in October are as firm and plump as those first produced; in fact, its keeping qualities are good, and the colour beautiful. This variety is a sure cropper, but requires more head room than some. The Old Red comes next in size and quality. This is a well-known variety and is very dwarf; it is also the latest in ripening, but gives way to General Grant in its keeping properties. The Orangefield is the earliest with me and very prolific; this should have a place in every garden, for though the fruit is small it comes in remarkably early, is very dwarf, and, as I said before, very prolific. Kaye's Early Prolific is very good, but is inferior to the Orangefield. This variety is known by the peculiar foliage, which has the appearance of suffering from want of water. Tomato de Lave is the last of those grown by me. This is very dwarf, scarcely exceeding 18 inches in height, still I have no doubt it might grow higher with coarser feeding. It is a very useful variety.

In giving the preceding list I do not for a moment wish to say that they are the only varieties suitable for out-door culture; no doubt there are plenty, but the above are what I find good. Where the space is limited the Orangefield for the early crop, and General Grant for the late one, are all that are required.—STEPHEN CASTLE, *Bent Hill Gardens, Prestwich.*

THE REV. C. P. PEACH'S GARDEN,

APPLETON-LE-STREET, YORKSHIRE.

It is not the description of a grand garden or "show place," in the usual acceptation of the term, that forms the subject of my theme; its title recalls no thought of extensive grounds, no vast ranges of glass houses, hardly any of the characteristic features of gardens of note, and yet I doubt not that it will be read with interest by all caring for a flower garden, and who have, like myself, profited by reading Mr. Peach's excellent communications in these pages. It was through one of those exhaustive papers on bedding Pelargoniums that I first became aware of the merits of Violet Hill Pelargonium. I had never seen it; but so convincing were Mr. Peach's notes on it and certain others, that I felt no hesitation in ordering those kinds which were perfect strangers to me, and certainly I have found most of them to be all that he has said of them. I qualify this last sentence, because some kinds of sterling merit do not succeed so well with Mr. Peach, or, rather, I should say, in the climate of Yorkshire, as they do in the south of England. As an instance of this I will take Crystal Palace Gem, which in Kent and in the neighbourhood of London far surpasses all others of its class that I have seen, being very compact in its habit of growth, with its finely shaped foliage so stout in texture that it never burns, but retaining its deep rich yellow colour in all its purity and freshness throughout the hottest summer, no matter how exposed it may be, thus proving a great acquisition; for who that has had much experience of bedding plants has not had to endure the vexatious loss of foliage in Golden Chain, the whitened surface or scalded margin of that of Cloth of Gold, or the vulgar gloss of Golden Fleeco? But, unfortunately for Mr. Peach, Crystal Palace Gem is anything but a gem with him, as it becomes so green as to be almost worthless. Need I point the moral? Well, I may just observe that severe

criticism would frequently assume a much milder tone if the effect of different climates, aspects, and soils on other things as well as on bedding plants were borne in mind.

To show how careful Mr. Peach is not to mislead the public, I may mention seeing a plant of Pelargonium Crimson Nosegay growing along with other novelties in a little trial garden, and upon my inquiring why favourable mention had not been made of it, Mr. Peach replied that he thought it a good variety, but as he had not seen much of it he refrained from assigning it a place in his list, which I can confidently say it fully deserves, for it is one of the most distinct and splendid sorts we have. Its very compact yet spreading habit of growth is all that one could desire, while the light blotch on its foliage causes its profusion of flowers, of a deep rich liquid crimson, to appear all the more striking.

The chief feature of interest in this garden is a long sloping curved border, partly enclosing a pretty flower garden in front of the vicarage; it is on this border that a number of the leading kinds of bedding Pelargoniums are grown and their merits compared. It is divided into many compartments in a very tasteful manner, with broad lines of *Arabis alpina* variegata so arranged as to form a band of diamond-shaped spaces along the entire length of the border. Each diamond contained a distinct sort of Pelargonium, and thus each variety fully displayed its good or bad qualities, and, by comparison with its neighbours, afforded the fairest test of its relative merit. A border of this description must be such a constant source of interest throughout the entire summer as to be far preferable to the most brilliant ribbon border, however perfect; and by introducing suitable plants in the vandykes or half-diamond spaces along its sides, it is rendered as attractive an object in its way as it is possible to conceive. Moreover, by such an arrangement a much fairer idea of the real merit of new varieties is to be had than could ever be gained from a sight of the single plants of our exhibitions, and which are generally all the material that a Floral Committee has on which to found its decisions.

It is not my purpose to give a detailed statement of the varieties of Pelargoniums grown by Mr. Peach, as he has already done so, but I may observe that among many new kinds of the Gold and Bronze section Crown Prince and Impératrice Eugénie appeared to be the best; and from a fine batch of specimen pot plants of the Nosegay class in one of the greenhouses I selected Mrs. Living, a remarkably free-flowering orange scarlet; Godfrey, of a similar shade of colour, but brighter and with very large trusses; Gloire de Corbeny, of a fine salmon shade; and Ne Plus Ultra, with immense trusses of bright pink flowers.

A mass of deep-coloured Beet surrounding some Centaurea in the flower garden had a tolerably good effect, but its vulgar glossy foliage will, I think, prevent its ever becoming a general favourite for such a purpose. A very compact-growing dwarf blue *Lobelia* named Little Gem was very good indeed; it is a lovely free-flowering variety, worthy of a place in every garden. Nor must I omit to mention a fine bed of mixed kinds of *Verbenas* enjoying a prominent position; and very worthy of it they were too, for to my mind there was not a more attractive bed in the entire garden. I never can understand what is meant when we are told that many of the best show varieties of Perry and Eckford are not good bedding plants. Planted thickly in deep, rich, cool soil, and with a little care in training and pegging, they form a lovely and interesting mass of bloom, which is quite certain to attract and please the most fastidious eye.

The glass houses are moderate-sized span-roofed structures, very compact, and with every inch of space turned to account. The plants which they contained were in a very healthy and creditable condition.

Some low portable frames, very useful and wonderfully cheap, were shown to me, and as they must be very serviceable for a variety of purposes I will give a slight sketch of them. They are made in two shapes; one is a regular span-roof, and the other a half-span. The span-roofed frames are undoubtedly the more useful of the two; they were 9 feet long by 3 feet wide, 11 inches high in the centre, and 3 inches high at the sides; there is a wooden division across the centre to which the sides are nailed, and so they are kept from warping. The panes of glass are moveable; they fit into a groove in the side of the ridgebar, and are kept securely in their places by a crooked pin at the bottom of each pane. The panes measure 16 inches by 20, and it takes seven of them along each side of the span. The cost of these fourteen panes is 8s. 6d. The boarding costs 3s., the painting 1s., and the making 3s., and so

we have a capital little glass roof, which you may set up as high as you like on bricks, and covering a space of 27 square feet, at a cost of 15s. 6d. I have seen no ground vinerias nor plant-protectors to equal these frames either for cheapness or utility, and for that reason I have endeavoured to describe them accurately. If I have omitted any important particular I am sure Mr. Peach will willingly correct me.—EDWARD LUCKHURST, *Old Lands, Buxted, Sussex.*

PLANTS FLOWERING IN OCTOBER.

- Oct. 3. *Fuchsia fulgens*
- coccinea*
- gracilis*
- microphylla*
- serratifolia*
- corimbiflora*
- albiflora*
- Achillea italica*
- Bombax stricta*
- Artemisia maritima rosea*
- Centranthus ruber*
- Kochia scoparia*
- Silene Atoleou*
- rufiflora*
- Zinnia elegans*
- Perilla nankaiensis*
- Verbena venosa*
- pulegiata*
- officinalis*
- Alonsoa compacta*
- Warszewiczii*
- Mathiola annua*
- Sedum spectabile*
- Rosa Gloire de Dijon*
- Lupinus naous*
- Abronia umbellata*
- Aconitum album*
- nemorale*
- japonicum*
- Viola odorata*
- tricolor*
- corata*
- lutea*
- Anoda Billeniana*
- Convolvulus minor*
- monstrosus*
- Eriotheca acanthifolia*
- Drummondii*
- Lamarkiana*
- bicinctus*
- macrocarpa*
- Selloviana*
- rubicunda*
- Tricyrtis hirta*
- Trifolium repens*
- Calceola Polka plena*
- Bibiscus africanus*
- Collinsia bicolor*
- Oxalis tropaeoloides*
- Briza maxima*
- Pentstemon gentianoides*
- coccineum*
- azureum*
- procerum*
- pulechellum*
- venustum*
- ovatum*
- Adonis autumnalis*
- Phlox russelliana*
- Viburnum Times*
- Ajuga reptans*
- variegata*
- gouevensis*
- purpurea*
- Campanula muralis*
- carpathica*
- garganica*
- grandis*
- gigantea*
- pyramidalis*
- pulla*
- Asclepias tuberosa*
- Dahlia*
- Bellis perennis*
- Antirrhinum*
- 11. *Veronica carnea*
- gentianoides*
- incana glauca*
- suicata*
- speciosa*
- Sedum album*
- Telephium*
- purpureum*
- Sieboldii*
- variegatum*
- spectabile*
- Verbascum nigrum*
- Vinca major*
- minor*
- Linaria alpina*
- umbellaria*
- purpurea*
- Phlox verna*
- procumbens*
- setacea*
- Rudbeckia laciniata*
- amplexifolia*
- Phloxibendron hirsutum*
- Batura stramonium*
- Oboliscaria pulcherrima*
- Salpiglossis atropurpurea*
- Veronica syriaca*
- Viscaria oculata*
- Erioc. stricta*
- ramentacea*

- Oct. 11. *Polygonum orientale*
- Centrantho depressa*
- ravinaria*
- Cerastium tomentosum*
- Buphthalmum salicifolium*
- Douglas Dantes*
- Arabis hirsuta*
- Cerieria muricata*
- Calystegia pubescens*
- Arenaria marina*
- Anemone japonica*
- Dianthus Caryophyllus*
- superbus*
- deltoides*
- casus*
- Chelone barbata*
- glabra*
- obliqua*
- Saponaria officinalis*
- ocymoides*
- 15. *Artemisia Dracunculifolia*
- annua*
- Teneraria variegatum*
- Sagittaria arifolia*
- Malva Moroni*
- Hydrangea japonica*
- hortensis*
- Tritoma Uvaria*
- Genorium argenteum*
- Echinops Ritro*
- aphrodisiacus*
- Helianthus didymus*
- multiflorus*
- Lycnis fulgens*
- chalesionica*
- Havesana*
- dionea*
- Dracoccephalum canariense*
- moldivicum*
- Loasa curandiera*
- Ecceimocarpus scaber*
- Cyclamen europaeum*
- heterophyllum*
- 20. *Craicella stylosa*
- Antholyza coccinea*
- Convolvulus cantabriensis*
- curtissimus*
- solidiflorus*
- Andryala laeta*
- Clematis Jackmanni*
- Beta maritima*
- Crocus speciosus*
- Borax*
- gracilis*
- autumnalis*
- Coronilla iberica*
- varia*
- Achillea tomentosa*
- Colchicum autumnale*
- Calandrinia umbellata*
- Tagetes pumila*
- Alouisia ciliiflora*
- Aster chinensis*
- Trichium*
- Senecio elegans*
- Genum rivale*
- coccineum*
- montanum*
- Hesperis matronalis*
- Vitadenia trilobata*
- Zauschneria californica*
- Ageratum odoratum*
- Tropeolum majus*
- 24. *Inula glandulosa*
- Salvia fulgens*
- patens*
- verbascofolia*
- coccinea*
- Thymus vulgaris*
- launginosus*
- officinalis*
- Nepeta violacea*
- Nierembergia gracilis*
- ryularis*
- Mecanopsis cambria*
- Monarda didyma*
- Lavandula Spica*
- Konigia variegata*
- Hibiscus roseus*
- Funkia cernua*
- grandiflora*
- ovata*
- Scabiosa lutea*
- germanica*
- Seropilaria variegata*
- antologia incana*
- alpina*
- Galium verum*
- Trachelium cernua*
- Eryngium alpinum*
- Lathyrus odoratus*
- grandifolius ramosus*
- Lophospermum scandens*
- Lupinus polyphyllus*
- Glaucum flavum*

- Oct. 21. *Linum alpinum*
- marboreuse*
- Lewisi*
- flavum*
- Eupatorium purpureum*
- Alyssum saxatile*
- Amsium salicifolia*
- Soltana flexuosa*
- cambria*
- 29. *Delphinium Belladonna*
- Hendersonii*
- Consolida*
- Arcotis grandiflora*
- breviscapa*
- Coreopsis grandiflora*
- lancolata*
- Aster grandiflorus*
- levis*
- levis*
- spectabilis*
- Ameilus*

- Oct. 29. *Aster Novi-Belgii*
- Novae-Angliae*
- bessarabicus*
- dimosus*
- Ceanothus azureus*
- Echeverria glauca*
- Hedysarum coronarium*
- Omphalodes verna*
- Myosotis alpestris*
- palustris*
- Oxalis floribunda*
- versicolor*
- speciosa*
- Gaillardia pecta*
- grandiflora*
- Chrysocoma Lynosyris*
- statae latifolia*
- Limonium*
- heptifolia*
- Stachys germanica*
- Pumbago verpaute*

—M. H., *Acklam Hall, Middlesbrough-on-Tees.*

PEAS IN 1870.

REFERRING to the comments on my article on Peas by Messrs. Carter & Co. on turning to my note-book I find that on July 9th, 1870, what I obtained for Ringleader (Sutton's) measured 3 feet 6 inches in height. The seed I procured in 1869 from a well-known firm in Manchester, at the same time I had a packet of Carter's First Crop from another firm here; both were sown at the same time and received the same treatment, but I saw almost immediately that they were two distinct varieties. Being fully aware of the old story respecting the two Peas, I determined to save my own seed of Sutton's Ringleader, and in order to have it fine I saved the pods that were well-formed, and with not less than five fine Peas in a pod, and the result this year has been the best row of Peas I ever saw, and certainly there are those in this neighbourhood who can bear testimony to what I say. I should add, the height last year was 3 feet. This year, though I grew Saogster No. 1, Dillistone's Prolific, and what was sent to me as Carter's First Crop, none proved equal to my own saved seed. I have saved this year sufficient for a single row, and at the proper time I shall, in order to get the First Crop true, send my order to Messrs. Carter & Co. for this and Laxton's Prolific. I have now before me two catalogues for 1870, of well-known old-established firms. In one, the height of Ringleader (Sutton's), or First Crop (Carter), is given at 3 feet, which is the height it grew with me in 1869. In the second, Ringleader and Carter's First Crop are made to read as distinct varieties. In conclusion I would ask, is it not possible for a system of high cultivation to raise the height of Peas? In my case I have proved that it does.

Coming to Mr. Gilbert's remarks, permit me to inform him that all gardeners are not aware of the fact of Peas requiring the ground being prepared as I have described, because, if they knew, I should both see and hear less of failures than I have been accustomed to do, as no one can make me believe that for the sake of a little extra labour he would endanger the crop of what I consider the best of vegetables.

In the next place, I hope Mr. Gilbert does not compare Manchester to Stamford, Prestwich being the same distance from Manchester as Burgley is from Stamford; if he does he is certainly wrong, both as regards rain and smoke; and, as I said, my Peas sown in March were as early as those sown in the previous November, leaving out of the question birds and mice. I speak this from experience, and certainly I consider my Peas gathered on the 18th of June as early as his gathered on the 6th of the same month.

Lastly, I can inform Mr. Gilbert, that to have Peas in October on this side of Manchester must be very rare, I myself having seen none; in fact, the subject of my earliness and lateness in Peas is spoken of by many, though I still hope to have later gatherings the coming year, though I despair of gathering here on Lord Mayor's day.—STEPHEN CASTLE, *Bent Hill Gardens, Prestwich.*

MESSRS. CARTER & Co. in your paper of the 3rd inst., page 345, say that "it is utterly incorrect that Sutton's Ringleader is 3½ feet high," and that they "challenge anyone to name an early Pea of 3½ feet high," which is earlier or so early as Carter's First Crop. As an amateur I have grown Sutton's Ringleader for two years; each year it has grown 3½ feet high, and would, I think, have reached 4 feet if it had not had the tops frequently pinched off. Daniel O'Rourke grew 4½ feet high, though it is neither earlier nor so early as Ringleader. There could be no mistake about the seeds, as I had them

direct from Messrs. Sutton. I think Messrs. Carter should make allowance for different qualities of soil and situation before they make such sweeping assertions as those expressed in the letter from which I have quoted.

I should be happy to give you some information as to the results I have experienced after cultivating in this northern climate a variety of dwarf Pear and Apple trees purchased from Mr. Rivers in 1864, if it would be of any interest.—E. H. D., *Lattendales, Penwith, Cumberland.*

[We shall be obliged by your notes.—Eds.]

PORTRAIT OF MR. RIVERS.

The following additional subscriptions have been received:—

	£	s.	d.
Fisher, Holmes, & Co., Sheffield	2	2	0
Fish, D. T., Hardwicke Gardens, Bury St. Edmunds	0	10	6
Newton, W., Esq., Hill-side, Newark	1	1	0
Press, W., Esq., 6, Crescent, Cambridge	1	1	0
Smith, C. Roche, Esq., F.S.A., Strood, Kent	1	1	0
Warner, Mr. Thomas, Leicester Abbey	1	1	0
Chapman, Mr. John, Kingstou Laey	0	3	0

MESSES. CARTER & Co., High Holborn, have issued a list of very liberal prizes which they offer for Mangel, Swede and other Turnips, Carrots, Beet, Parsnips, and Cabbages. Those who intend to compete should send at once for a schedule, as specimens must be sent by the 20th inst.

USE OF A DAMPER—CIRCULATION OF HOT WATER.

WHAT is a damper fixed into a furnace chimney for? I say it is to regulate the draught of the fire from the boiler, and ought to be kept closed, or nearly so, when the heat in the houses is up to the degree wanted, as the damper confines the heat round the boiler, and also keeps the fires in during sharp frosty nights.

One more question. I can never get our fernery heated to more than 55° this dull weather, and often find the temperature down to 40° or 38° these cold mornings. Last winter I could hardly keep frost out at all. There is plenty of 4-inch piping all round, but it is the setting, for where the pipes which go all round the house enter from the boiler, they are higher than the other end by nearly a foot; consequently the water does not circulate. At one end of the house the pipes are hot, and at the other nearly cold. My employer says he had this done to keep one end warmer, but I think it a very unscientific idea altogether. Did ever hot water go down hill? I will not believe it will, and as a proof, last winter was so severe, and I had to keep up such a large fire, that in trying to get the house up to a certain heat the pipes burst close to a joint through the pressure. There are no air-pipes in the elbows. What can a gardener do? Just for the sake of a few shillings to have the pipes readjusted in a proper position, and not to hear reason, an employer sees his plants half dead all the winter; besides the double amount of fuel consumed, and argument and strife between employer and employed.—*POOR GARDENER.*

[On the general question I agree with you, if the matter is stated correctly, and consider that your employer's ideas on heating are altogether wrong, and if continued to be carried out will not only be a source of unpleasantness to the gardener, but of great loss and waste of fuel to himself. There is one matter to which I would allude, and that is the question "Why should an employer interfere with a head gardener's management of his fires, &c." Why, indeed! But then you must own he has a perfect right to do so—nay, more, it would often be to the general advantage if this were more done than it is. Many a ton of coals would be saved, and the labour of the stoker made lighter, if employers more thoroughly entered into this and other matters. I say thoroughly, because no intelligent gardener could long put up with mere ignorant meddling for the sake of meddling. But this I will say, that the employer who knows most about firing and stoking will be the most considerate in estimating the labours and attention of the fireman. The more generally intelligent even on gardening an employer is, the worse it will be for a mere pretender but the better it will be for an intelligent attentive man, who does not only know but practise what he knows. In many cases here-

before I have shown that I can stand up for the gardener, but with all that I must still come to the conclusion that the man who spends the money in a garden has a right to spend it in his own way, and if one of these ways should be that heated water is to be forced to run downwards as a general principle, then the gardener, having courteously stated his opinion, and finding that the places cannot be heated on that principle, must be content with these disadvantages or take his services to a more appreciative market.

Now to the general matters. I never like a damper to be quite closed, as that is dangerous, and, perhaps, a hole from half an inch to an inch in diameter in the centre is as good a safeguard as any. If the damper is not for the purpose you state, what is its use at all? If your employer is right in having it always out, what is the use of having it? Would it not be better to have none? Or, by the way, does he think that by the damper being always out there would be a stream of cold air always beating back the hot air round the boiler? I would rather use even in this respect the damper in the usual way, and have a small opening for fresh air beneath it. I can think of no other reason why a scientific engineer should wish the damper always to be out in connection with a furnace that heats a boiler.

I do not see how you can heat the fernery properly—though there are plenty of pipes—with the pipes where they enter the house a foot higher than at the farther end, and no openings or air-pipes. No wonder your pipes burst, and you get no heat to speak of at the farther end. Still it would be wrong to say, "Did ever hot water go down hill?" for with atmospheric pressure it will do so, though not in such close pipes as yours. With an elevated cistern open, and an open air-pipe at the farther end, there would be circulation. Even with an open air-pipe a couple of feet above the pipe where it enters, and one 3 or 4 feet high at the farther low end, I would not despair of circulation—in fact, I see it in operation daily, but then the plan is not so good as when the pipes are on a level throughout, or with a slight rise to the extremity, and a small air-pipe inserted at the highest point. The air-pipes might be tried before lifting the pipes; but if even that be done, the heating will never be properly effected, and the firing must be alike expensive and dangerous. As to advice, I do not see how I could further help you. There are matters with which a stranger cannot well intermeddle. I know this, that no gentleman will find it to his advantage to lower a head servant whom he wishes to keep before that head servant's assistants. Another thing I have often thought of. I once heard some man complaining of a grievance to the late Dr. Lindley. "Well," said he, "I cannot sympathise much with you, I have got now such a rhinoceros hide that each bitings as these would never be felt by me." Well, I suppose some of us get thicker-bided as we grow older; but there are some things which one cannot stand, and should make one change rather than endure.—*R. FISH.*

AMONG THE CHRYSANTHEMUMS.

Go into what quarter of London you will, there at the present season you are sure to meet with this autumn flower. In some cases you will find it, to use a gardener's expression, "well done," in others "ill done;" but still you will find it. Up north and to the west you will find it in perfection; on the south side very good; "down east" we have not travelled much of late, yet we are assured, despite all drawbacks—smoke, and foul air, and poverty—there, too, the Chrysanthemum is cherished. Well it deserves to be so; it enlivens what is generally in London the gloomiest month of the whole year; in the poor man's fore-court, in the rich man's conservatory, it is equally welcome; it flourishes in an old teapot in an attic window, and adorns a costly vase. Its powers of withstanding smoke, and the brightness and variety of its colours, render it one of the best of London plants, and by Londoners it is duly appreciated. It is, however, more especially up north that the Chrysanthemum has found a home. Stoke Newington was the place where the mother Chrysanthemum society took its origin, there the flower is still fostered with every care, and thither we shall first bend our steps and visit.

MR. FORSYTH'S, BRUNSWICK NURSERY.—Here the show house, arranged much the same as in former years, is certainly quite as attractive. It would be tedious to name all the fine varieties which are here to be seen, especially as we have given them from year to year, but a few of the best we will particularise. White Globe is this year generally fine, and the blooms

are of remarkable size and beauty; Mrs. George Rundle, another white, though not nearly so large, is one of the finest kinds known for specimens; two plants of it which Mr. Forsyth had for exhibition were models in respect to growth, and covered with bloom. Of Queen of England, blush, there were blooms quite 6 inches across; Beverley, white, was very fine, as it usually is; and Golden Beverley, a sport from the former, equally fine in its shade of colour. The following were very conspicuous—viz., Prince of Wales, purplish violet, very large, and finely incurved; Prince Alfred, rosy crimson; Princess Beatrice, rosy lilac, with a silvery tinge, and peculiarly beautiful; Faust, bronzed crimson purple; Bronze Jardin des Plantes; Le Grand; Lady Harding; Little Harry, not large, but excellent for specimens, and a charming flower; Princess of Teck, white; Lord Derby, finely incurved, dark purple, and of very stout substance; Lady Slade, beautifully incurved; Hereward, very fine; and Jardin des Plantes very rich in colour. Virgin Queen is of the purest white, and very fine; Pink Pearl, though small, is very pretty; and Empress of India, white, is very large and beautiful. Venus, likewise, is very pretty.

Duchess of Roxburghe, large and with broad florets, orange, tinted with rose, is a fine incurved flower, sent out in the present year. Another new one, Mr. W. H. Morgan, a seedling of Jardin des Plantes, but lighter in colour, is said to exceed its parent in size, but at the time of our visit it was not far enough advanced to judge of this. Robert Bruce, rich crimson, had not attained its full size, but is said to be even better than Dr. Sharpe for specimens, and how good the latter is the five plants which Mr. Forsyth has are a sufficient proof. Mr. Cole, blush, promises to be a good addition to the Anemone-flowered class.

The Japanese kinds, so excellent for conservatory decoration, being for the most part later than the incurved kinds, were not at the time of our visit all fully out, but James Salter, lilac, a highly-decorative variety, and Dr. Masters, yellow, with an orange centre, were in full beauty, and very large and showy they are. The Daimio is another splendid kind; Red Dragon is rich in colour; while of ambers and yellows there is a superabundance in Comet, Meteor, Jupiter, Prince Satsuma, and The Mikado. Chinese Orange Incurved was noticeable for its size and being beautifully incurved; the florets are streaked with red on the inside.

In running through the houses, which are filled with bedding plants and a large stock of others which Mr. Forsyth employs for an extensive furnishing business in the west end, one meets with many excellent specimens of Pompon Chrysanthemums, especially of the different kinds of Cedo Nulli, Golden Aurore, Salamon, Bob, &c., and such of the large-flowering class as Annie Salter, Defiance, and Dr. Sharpe.

THE TEMPLE GARDENS.—The late Mr. Broome—our worthy kind-hearted friend Broome—who did so much to popularise the cultivation of the Chrysanthemum, not only in London but all over the country—who with heart and hand entered into every movement which was likely to advance the interests of his favourite flower—he has passed away, but he has left his mark. It was one of his ideas to have the long border facing the river, where his best specimens were, covered with glass, and that has been done this year, and a very great improvement it is. His successor, Mr. Newton, deserves great credit for the manner in which he has kept up the reputation of the Inner Temple Gardens by the excellent display he has made, and which from the improvement just noticed, is seen to much better advantage than the shows of former years. As usual, both to it and Mr. Dale's, in the Middle Temple, there have been thousands of visitors.

The best border, as it is termed, is about 35 yards long, and from its extent is filled with a great number of fine varieties. The following may be noted as the most conspicuous for the size and beauty of their blooms—viz., White Globe, Beverley, Virgin Queen, Jardin des Plantes, Golden Beverley, Guernesey Nugget, Lady Talfourd, Faust, Prince Alfred, Christine, Attraction, Prince of Anemones, Mrs. Huffington, Mrs. Sharpe, Progne (fine in colour), and Mr. Brunlees; and among the Japanese, James Salter, The Tycoon, and The Daimio.

Great improvements have been effected to these gardens since the Thames embankment works approached completion, by widening the terrace and laying out the beds afresh, and yet more are in contemplation. The principal beds, much enlarged are now planted with bulbs, so we may anticipate a good spring display. Mr. Broome's mantle seems to have fallen on a worthy successor.

IN THE MIDDLE TEMPLE GARDENS, Mr. Dale has a less extensive display under cover, but the blooms both in size and perfection are everything that can be desired. Guernesey Nugget, primrose, is very fine, so are White Globe, Jardin des Plantes, Little Harry, very pretty, General Slade, Nil Desperandum, Antonelli, Prince of Wales, Astrolabe, Cherub, Rev. Joshua Dix, Lady Harding, St. Patrick, Sparkler, and Mrs. Halliburton, the last a charming little flower.

In the beds and borders Mr. Dale is always strong in Pompons, and this year they present a fine mass of bloom. The different sports of Cedo Nulli, Canrobert, Salamon, Mrs. Campbell, Madame Rousselon, Dru Drin, an old sort, but still one of the best; Darullet, St. Justine, and Madame Pèpin, form fine masses. Mr. Murrey, a violet rose hybrid kind, is also very attractive, so is Julie Lagravère, one of the small-flowered kinds of the large-flowering class. Mr. Dale may well be congratulated on his success this year, although he has long been known as one of our best Chrysanthemum growers.

GARDENERS' DIFFICULTIES.

THE difficulties of the season prompt us to take the opportunity of saying it would be well if the employers of gardeners took such matters more into consideration when expecting the regular supply independently of what the weather and the season may be. And, again, it would be well if we gardeners in general, though appreciating the consistency and the kindness of such consideration, would yet trust as little as possible to it, but do everything to make up for drawbacks and deficiencies, so that these should be felt as little as possible. This is the best course, at least for us, to pursue, and the man who adopts it, if there should still be some talk of deficiencies, will have the self-satisfaction of feeling that he did what he could, a matter of great importance so far as true happiness is concerned. We know of cases where the knowledge of drawbacks connected with the dryness was well known and sympathised with; but the drawbacks were forgotten, and the usual returns at once expected at the first favourable change in the weather. We fear that there might be cases in which the gardener depended rather too much on sympathy, and not enough on his own additional efforts to prevent the drawback being much felt. Employers cannot be expected to be so taken up with all drawbacks as we are. An early frost will make havoc with fruit blossom, but that is forgotten in the fruit season. Early-bedded-out plants may be almost cut down to the ground, but though planted in obedience to orders, the casualty is apt to be forgotten when there is a deficient massing of early bloom. A thunder or a hail storm may do much mischief, but we suppose it is natural to forget, or at least not desire to have these matters broadly obtruded in fine weather and bright sunshine. Very often after such a casualty the mild zephyrs will blow, and the sun will shine brightly as if to tantalise us. It is often impossible entirely to neutralise such evils, but much may be done by way of prevention, and much in the way of mitigation, so as to keep the effects from being so much seen and felt as they otherwise would be. We may rest assured that all drawbacks and difficulties are apt to be forgotten as soon as they have passed away, though without extra effort and thought the results would be long seen and continued. It is best for all parties that defects, even from unavoidable causes, should be as little seen as may be. The subject embraces many sides. We do not now enter upon such a case as where there is a recognised agency continually at work undermining the efforts of the gardener, who can only do his duty by these matters being thoroughly recognised. It is more ordinary drawbacks from seasons and circumstances to which we would refer, and our meaning may be rendered more clear by two or three illustrations.

During the past season some gardens would have been little better than a desert without mulching and shading. We heard of one place where the bedding plants had been turned out rather early, and were much injured by frost, and were then philosophically left to their fate, a fate involving great disappointment. We heard of another similar case, but the extra care and bringing in small reserve plants prevented the evil being at all seen by the middle of July. A lot of bullocks got into a flower garden, trampled the beds in the end of June, and tossed and broke the flowers, and it was to a great extent left to its fate. Another had been invaded by sheep breaking through and scarcely leaving a green thing, but by increased energy, with other plants, annuals, &c., the garden was soon very attractive. A gardener was told that the men must be

reduced for a time, and he then left some favourite flower beds unfilled, though nothing would have been said if he had left uncropped or sown down the half of the kitchen garden. We will not now agitate the question as to who would be the most trusted servant of these men, we shall be satisfied if our young readers merely decide who was the most likely to feel the

greatest amount of self-respect and satisfaction. Be assured all drawbacks, even those over which we have no control, will soon be forgotten, and it is true wisdom to prevent them as far as possible from obtruding in their results upon the attention. It is better to remove a tree than leave it standing after it has been scathed and blighted.—R. F.

CASTLE HOWARD.

THE SEAT OF THE EARL OF CARLISLE, NEAR YORK.

No. 2.

In the centre of the garden is an elegant fountain (*fig. 4*), to the right and left of which were two fine bold groups of beds precisely similar in appearance. Each group was composed of a central pedestal supporting a tazza well filled with Pelargoniums, surrounded by four circular beds alternating with a like number of curved-out parallelograms; the circles contained Pelargoniums, and the parallelograms Hollyhocks. Along the extremity of the flower garden is a fine raised walk, forming a most agreeable and commanding promenade. At one end of this walk is a striking group of statuary representing Hercules wrestling with Antæus, and at the other end there is an equally bold representation of the Rape of Proserpine.

From whatever point of view one looks at this fine flower garden its appearance is entirely satisfactory. It is the work of

Mr. Sutherland, the gardener, and reflects much credit on his taste and skill; it is not only very elegant in its design, but by its fine proportions and the chaste character of its accessories it is peculiarly suited for its important position.

From the raised walk another walk leads in a straight line under the overhanging branches of trees, to a commanding figure of Apollo, standing on a rough-hewn pedestal of rock, on a circular plot of turf, encircled by the walk margined by Lime trees. At right angles with the walk leading to this spot from the flower garden is another fine walk up a Lime avenue, so that it will be understood how very suitable this figure is for the situation it occupies. A noble walk leading in a straight line from some important part of a garden or pleasure ground, or from the mansion itself, should always have some object of interest at

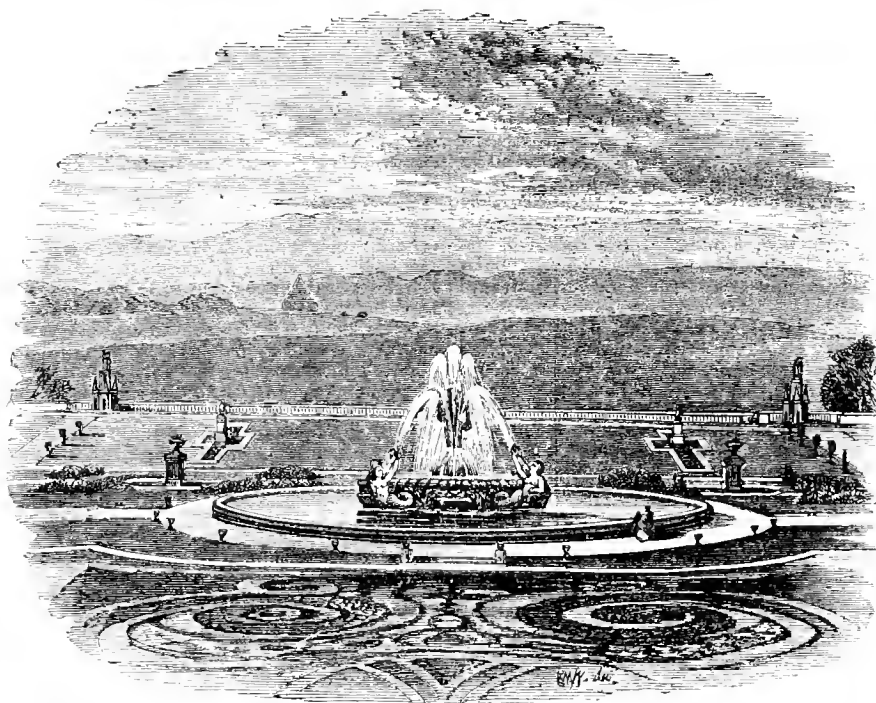

Fig. 4.—The Fountain.

its extremity, as an important work of art, or a noble specimen of some choice kind of tree, or else lead to a commanding position overlooking fine scenery.

Opposite the garden front (*fig. 5*), I was shown an Irish Yew planted twenty years ago by Her Majesty the Queen, and a *Cedrus atlantica* planted by the late Prince Consort; both trees were in a thriving condition. Many handsome specimens of Wellingtonias, Deodars, and some fine Cedars of Lebanon were dispersed about the grounds.

The kitchen gardens are very extensive, there being nearly eleven acres enclosed by fine walls, with interior cross walls. The principal entrance, with its ornamental stone pillars and elegant gates of ironwork, presents a fine appearance. Many of the walks had ribbon borders along each side, all very bright and beautiful. Some persons possessing peculiar views concerning the fitness of things object to such bright floral displays in the kitchen garden, but where space can be spared to fringe the walks with lovely flowers by all means let us do so. A well-

cropped kitchen garden, with its beds of flourishing vegetables arranged with geometrical precision, its symmetrical fruit trees, and the freshness and peculiarly neat appearance which everywhere prevails, is a very attractive sight, fraught with interest and instruction; and if to this we can impart an additional attraction by the aid of a bright flower border or two it is surely wise to do so. I am myself at present engaged in making a new kitchen garden, and by the wish of my employer there will be flower borders along each side of the central walk, which, as it is in a fine sunny position, will form an agreeable promenade; and I was amused at the exclamation of a visitor lately, "What! Flowers in the kitchen garden!" which he evidently considered rank heresy.

The ranges of glass houses are not all together, but are so scattered about—it I may use such a term—as to present a somewhat disjointed appearance. In a fine lean-to each house, the trees, trained to a curved trellis along the front part of the house as well as on the back wall, were in a very healthy and

vigorous condition. Mr. Sutherland spoke highly of Prince of Wales Nectarine, which had fruited well in this house. In another Peach house the condition of the trees was equally satisfactory. In a long low vinery the Vines had an even crop of fruit, not very large in the bunch, but with good-sized, well-coloured berries. Madresfield Court is a splendid new Grape; it had a good crop of long taper bunches, and its fruit, which I was allowed to taste, has a delicious Muscat flavour. This fine

variety is worthy of a leading position among our late Grapes. The Peach trees on the open walls were bearing well. The culture of hardy fruits evidently receives much attention here. A collection of pyramidal Pears were really magnificent trees. The collection of Apples was even more extensive. The bush fruits, too, occupied a very considerable space, and I particularly noticed some fine standard plants of Red Currant. The crop of Strawberries had been good, and Mr. Sutherland agreed with me



Fig. 5.—The Garden Front.

that Dr. Hogg is one of our most valuable kinds; it had been particularly fine here.

The soil of this garden is a fine deep rich loam, and the vegetable crops growing in it were abundant and good. Myatt's Prolific Ashleaf Potato is a favourite kind here. A heavy crop of it was being lifted at the time of my visit. I was also shown some fine crops of various new sorts of Potatoes, such as Early Rose and Climax, but refrain from any farther mention of

them, as Mr. Sutherland purposes contributing a paper on this subject.

And so I left Castle Howard, after experiencing much kindness, to which Mr. Sutherland added by assisting me on my way to see Mr. Peach, whose practical and instructive papers we all read with equal pleasure and interest, and concerning whose garden I will tell a little in another paper.—EDWARD LUCKHURST, *Old Lands, Burted, Sussex.*

WORK FOR THE WEEK.

KITCHEN GARDEN.

THE great amount of rain which has fallen recently has generally interfered with the progress of out-door operations. All fine days should now be turned to account and held of value, owing to the uncertainty of their recurrence. As full-grown *Coleworts* turned into heads, like young Cabbages, are rather impatient of frost, it is advisable at this period to take them up and heel them in near the frame ground as thickly as they can lie together, covering them up, as soon as they are slightly frozen, with new straw, and laying a few stakes on them to prevent the wind removing the straw. By these means the ground is set at liberty for trenching, and one can preserve with certainty fine young Cabbages all the winter. Whatever may remain of *Celery* earthing should in favourable weather be attended to. The weather has favoured the eluge, if nothing else lately; they must be closely looked after, or the destruction of the young and tender Cabbages and *Lettuces* will infallibly be the consequence. *Haricot* and *Kidney Beans* not sufficiently matured for preservation for seed, may, nevertheless, be supplied to the table. They will form an excellent

and wholesome dish. Place some straw covers or old lights on the best *Parsley* bed, for fear of snow, also on the *Normandy Cress*. Look well to winter salads. Plant *Shallots* on raised beds; dig plenty of manure in, burying it deeply, and surround the bulbs with sand in raised drills, covering the bulb just overhead. Protect from frost *Rhubarb* intended for forcing, and remove all dead and decaying matter from both the *Rhubarb* and *Sea-kale* beds. Any kitchen gardener without a tank to receive the drainage of the dung-heap, or for the mixture of manure water, should speedily remedy the omission.

FRUIT GARDEN.

In planting and selecting fruit trees for the kitchen garden it is of great importance so to prepare the soil that the trees shall be as far as possible independent of extreme seasons, whether of moisture or of drought, also to take care that they do not make superfluous wood, giving much extra trouble to the pruner, and choking the surrounding vegetables or flowers. To accomplish this, it is found by experience that limitation of the roots is absolutely necessary, more especially as to depth. High planting also tends to the same result, but this in itself

is not complete, inasmuch as it cannot provide against the vicissitudes of climate, which provision, as before observed, should be the keystone of the arch. Thorough drainage is the first step, provided the soil harbours moisture. This being properly accomplished, some good strong loam should be provided if possible, be the soil what it may (unless a new garden and of a heavy nature), in order to mix with and refresh the old soil, which in the majority of old gardens is what is termed effete or worn out, however imposing its colour and consistence may be. Eighteen inches of sound soil for the average of fruit trees is considered better than a greater depth, provided top-dressings are made use of in very dry and hot periods. This should be placed on a mound (6 feet square) of brickbats or broken stones covered with a coating of cinders to keep the drainage porous. The limits of a calendar will not allow of more being said on this head; it may, however, be acceptable to enumerate a few fruit trees which ought to find a place in small as well as large gardens, merely premising that the list is not to be considered complete in itself, but merely as furnishing a few hints. Of *Pears*, procure the Jargonelle, Dumore, Marie Louise, Aston Town, Althorp Crasanne, Fondante d'Antonne, Paase Colmar, Winter Nelis, Glou Morcean, Ne Plus Meuris, and Baurré de Rance. *Peaches*—Pourpice Hative, Royal George, Noblesse, Bellegarde, and Late Admirable. *Nectarines*—Etruge, Violette Hative, and Old Newington. *Apricots*—Breda, Royal, Shipley's, and Moorpark. *Plums*—Précoce de Tours, Orleans, Reine Claude Violette, Washington, and Lekworth Inégatrice. *Cherries*—May Duke, Downton, Elton, Bigarreau, Late Duke, and Morello. These stand nearly or quite in the order of their ripening. In addition to these, of *Apples* procure the Early Harvest, Kerry Pippin, Early Nonpareil, Ribston Pippin, Pearson's Plate, Pitmaston Nonpareil, Old Nonpareil, Starmer Pippin, and Lamb Abbey Pearmain, all table fruit. As kitchen Apples, Manks and Keswick Codlin, Bedfordshire Foundling, Blenheim Pippin, Dumelow's Seedling, Wheeler's Russet, and Northern Greening. To these may be added others of very excellent character. Anyone, however, desirous of planting a moderate-sized garden would do well to obtain these kinds.

FLOWER GARDEN.

During the present month more than common attention is required to preserve the garden from the desolating effects of the weather; all traces of the sedulous care and cleansing of one day may be effaced by the storms of the next. Flat or ill-drained and constructed gravel walks will suffer from depositions of mud from pools to which such walks are liable, which, if not removed immediately, will destroy the appearance and value of the gravel. Examine all gratings, drains, and watercourses, and prevent as far as possible the evil above alluded to. The value of a well-drained exposed walk, free from the shade and moisture of trees, will be appreciated by those who recognise the importance of exercise and fresh air in all weathers and seasons. Walks subject to moss had better be raked and left in a rough and loose state during the winter. Proceed with planting; the present is the best time for removing large evergreens. Roll and cleanse lawns from worm-casts; lime water may be employed to destroy worms if too numerous. Transplant Sweet Williams and single Wallflowers into borders to replace the gay but tender beauties which fade on the approach of winter. Plant bulbs, and examine those previously set. All things liable to injury from severe weather, and which are requisite for another year, should be placed under protection without delay. Such as Fuchsias, Lobelias, Pelargoniums, shrubby Calceolarias, Salvias, Tiguidias, &c., will require this treatment. Modes of storing them away differ in different situations. Some can afford pits, some can spare even house room, and some are driven to the cellar. Whatever mode be adopted, let it be borne in mind that confined damp is nearly as prejudicial as frost. A lean-to shed is a very good place, and plants with a ball of earth dried on them after the manner of Dahlias, will keep very well there, plunged in coal ashes, with the addition of an old mat and a little straw over the shed during very severe weather.

GREENHOUSE AND CONSERVATORY.

Some of the very earliest Chrysanthemums may probably be getting past their best, and should be replaced at once by something of a more showy character. Whilst the principal collection is in bloom, a selection should be made of the best and most useful sorts, for there are many worthless varieties in cultivation, and it is better to grow duplicates of the really good kinds than to retain such as are but indifferent, merely for the sake of having a long list of names. Be careful not to let

things in bloom suffer from the want of water. Give weak clear manure water to Chrysanthemums, Salvias, Camellias, &c., and use every means to keep specimens in bloom as long as possible. Damp and mildew are the great enemies to be guarded against in the greenhouse, and these must be sharply looked after, especially in the case of plants that have not well ripened their growth, and are in a rather soft state. If the former is troublesome it must be dispelled by means of free ventilation on mild days, using a little fire heat at the same time, and for the latter a dry airy atmosphere is the best preventive; but the plants should be frequently examined, applying sulphur on the first appearance of the enemy. Very little water will be required here at present, but the plants should be carefully looked over about twice a-week, so as to make sure that nothing is allowed to feel the want of it. If not already done have the plants tied with the least possible delay, for it is very difficult to tie a plant so that it will not look somewhat stiff and unnatural, and the sooner this kind of work is done the better the specimens will look when in bloom.—W. KEANE.

DOINGS OF THE LAST WEEK.

KITCHEN GARDEN.

Mushrooms.—Lately the reasons were given why a bed should be made late in an open shed, and should be deeper than usual. We did not wish to wait long before the bed was fit for spawning, and made, as it was, chiefly of litter partly worked and sweetened, and covered with a slight layer of horse droppings, we had the material so arranged that we could have a regular mild heat to permit of spawning early. The bed would not average more than from 15 to 18 inches in depth, and the heat obtained was not very strong, and quite regular throughout, but we had to wait fully three weeks before the heat was mild enough for the bed to be spawned. To gradually lower the temperature sooner we had the surface of the bed made as firm as possible, and a little earth thrown over it, but still the heat kept quite regular, but fully 10° higher than we would wish to trust the spawn in. We spawned at about 85°, and the heat continues very genial and uniform after the earthing-up—merely a few degrees less than the above, so that we have no doubt that the spawn will run well, and with covering, to keep cold from the bed, we think it will bear well. What we want to impress on the beginners in Mushroom-growing is simply this—that often they must exercise patience.

Not being able to use our Mushroom house, we should have liked to have spawned this bed a week or a fortnight earlier, but had we done so most probably the spawn would have perished. No doubt the close muggy weather rather put us out in the calculation as to time. In our younger days, under similar circumstances, and according to old customs, we should have bored the bed with holes to let the heat out. We have long regarded this plan as chiefly acting by wasting the strength of the material by letting air into the bed and causing it at first to heat more violently than if air were excluded. Much of the intricacy in such matters, as well as the whole theory of making up a hotbed to give a lasting heat, would be better understood if we would only recollect that a lasting heat is best sustained by admitting merely a small quantity of air to support slow decomposition: hence, frequently, when a bed becomes cold, turning it over when too close will cause it to yield a nice mild heat for a month or two longer. A little moisture will often do the same when the bed has heated itself dry: hence, too, the importance of not having the material too much decomposed before making it into a bed. It then becomes too close for air to get in, and cools. We have made beds in a very rough way in March and April, and they had not lost their heat in the following November. The most experienced, however, will often be deceived, and thus we had to wait for the spawning of that Mushroom bed a fortnight longer than we expected.

Cucumbers.—The plants we put in frames and in hot-water pits early in spring are still bearing, though now coming more weakly. Those in frames have merely had the frames banked-up with litter, and the plants are much stronger than those in the hot-water pits. The beds were made large at first, and with the exception of the banking-up they have had no lining. If we did not want the frames we feel sure that adding a good lining to the depth of the bed would cause them to continue for some time, as that would throw in more bottom heat, as well as secure an atmospheric temperature of from 60° to 70°. These plants had their roots confined at first to about the third

of the width of a 6-foot frame. In the course of the season they received some rich top-dressings, and the surface roots were allowed to run all over the soil in the frame. In the pit the place for soil is about 3 feet in width, the width of the pit 6 feet. There is a sunk pathway behind, the soil is put in front, and the plants are trained about 15 inches from the glass. As we wanted fruit early—that is, as soon as possible after planting, we did not turn out the plants into this narrow pit, but placed them singly in large pots, and then packed round the pots some sweet hot tree leaves. As the plants grew they were earthed-up, and the leaves were covered several times with rich compost, until early in summer the pots were hidden and the roots running into the surface of the narrow bed. We know no better plan for quick fruiting, and then continuous fruiting from the same plants. Even these plants are now to us the subjects of a little anxiety. We have fruited them heavily of late, expecting to want more Cucumbers than we did, and now we would remove and plant afresh, but for the likelihood that many fruit might be desirable a fortnight or three weeks hence, and we should not like our strong young plants to fruit under six weeks. We have five of these lights in this position, and we can hardly give justice to the young plants where they stand. We have three lights planted in pots as described above and growing nicely, but from these we take off every young fruit as it shows itself, for we well know that if young plants bear freely in the dark short days of November, it is of little use to expect much from them at Christmas and the new year, and in the following months. Even young plants in spring are injured by much early fruiting, but not in comparison to what they are in November and December. We have known cases of unpleasantness, because with every advantage plenty of fruit would be obtained up to Christmas, but few or none for parties after the new year. There is a great advantage in span or steep-roofed houses over flat pits, keep the glass as clean as one may; but even under the most favourable conditions, plants that bear heavily before Christmas will not in general be so fruitful and healthy afterwards.

FRUIT GARDEN.

We are sorry to say that though Apples promise to keep pretty well, Pears with us are not only earlier than usual, but are keeping but badly. Many Marie Louise, Louise Bonne of Jersey, Beurré Bosc, and Beurré de Capiaumont, when changing nicely became at once like a mass of jelly. Could this be owing to the excessive dryness, followed by the warm rains and muggy days of the autumn, and to the very rapid growth so late in the season? Of the sorts alluded to, and others, we have had fine well-flavoured dishes, but we have lost, and quite suddenly, too, more than we ever recollect doing before. A very short time elapsed between the time that they were scarcely ripe enough for the table, and the time when they were too far gone to be of any use. The fruit room requires more attention in sorting out all spotted and decaying fruit than usual.

Planting, as previously stated, cannot be proceeded with too early now, as the leaves and wood are ripe enough to permit of the roots being moved. In all cases where the growth is too luxuriant, a little root-pruning, so as to cut the perpendicular roots will be useful. Shallow planting and surface mulching will, however, in general, induce enough of fertility without the necessity of root-pruning; and with even a moderate recourse to summer-pinning, we are persuaded that low horizontal cordon training, when once it becomes more general, will pretty well render tree-lifting and root-pruning, to insure fertility, unnecessary. In planting favourite fruit trees, a few barrowloads of fresh manure will ever be an advantage.

Strawberries in pots we have protected from the drizzling wet. We hardly know as yet how we shall secure them for the winter. We lost many of the best plants last season from rats and mice. The most tempting baits seemed to be of no use as long as there were the crowns of the Strawberry plants to go to. Singularly enough plants in the open ground were not touched, or but little.

Vineries.—We looked over late Vines to pick out any diseased or, rather, spotted or moulded berries. We kept a little fire, with air on, every day, and leave a little ventilation at night when not frosty. As, unfortunately, most of the roots are in the open ground, we covered the border of the late viney with litter to keep the cold out, so that the leaves may be encouraged a little longer, and likewise covered the earlier borders with litter to prevent the heat of the ground escaping, as it is much more easy to keep heat in the ground than to beat the soil at an early period after it has been thoroughly cooled by

frost. A foot of litter or fern will be more safe and effectual now than more than double the quantity of fermenting material in spring.

Pruning may be proceeded with as far as all the hardier fruits are concerned. Those who have the heart may destroy tom-tits now by placing poison in the places in deformed Pears, &c., left for them to peck. They have done but little damage this season, and have only come in to nibble fruit not worth housing. During the summer they well-hunted over the trees in search of even a stray green fly. We have seen them busy at 4 A.M. peeping anxiously beneath each Peach tree leaf.

ORNAMENTAL DEPARTMENT.

In order that the pleasure grounds should look well even at the beginning of November, the beds were all picked over—there being still a good deal of bloom—and the lawns mowed, machined, swept over, and rolled, along with the walks, so that all now for a time should appear fresh and flourishing. To effect this and save some of the more tender kinds of Geraniums, these were covered in the frosty nights at the end of the month with mats, removed in the morning before breakfast. Some of those which we wish to save we shall take up before this is printed. The general cleaning gave us a great advantage, as the tree leaves, short grass, sweepings, &c., thrown into a compact heap soon heated, and there, with a covering of more mellow sweet material, will give a nice bottom heat to many of the Geraniums we shall take up and pot. This bottom heat, with air at top and bottom of the sashes in moderate weather, will cause fresh roots at once to form, and when they are formed, and the bottom cooled by degrees, the plants will stand wherever they can be airy and the frost be kept out. Most of the finer tricolors and the variegated Geraniums do best when thus treated, and potted singly in small pots. The green and zonal-leaved sections do well in the same way, but may be kept treated in the faggot style lately alluded to, on the principle that vitality is merely preserved, but with little growth in roots or stems before March.

As the days are shorter and the sky more clouded we removed and thinned the festooned creepers in the conservatory, &c., so as to admit more light. We took most of such plants as Chrysanthemums in pots, if not into the conservatory and corridors, at least into places where protection could be given; also Cytisus, so that they might be well syringed, tied, &c., before going into their winter quarters.

In our cold pits we have put in our Calceolaria cuttings, as alluded to last week. If we have not much frost they would do exceedingly well any time this month—better, in fact, than if inserted in September or the beginning of October, for then they would, owing to rooting earlier, require more care in winter. This muggy weather Auriculas in pots under a frame should have air back and front, but be carefully protected from rain and drip, which, especially the latter, ruin so many fine plants. The surface soil should be frequently stirred to keep all sweet, and this will be helped with a dressing of rough dust charcoal, not fine. If the pots are plunged the plants will need little or no water until spring. Carnations and Pinks which are potted cannot have too much air in mild weather, but they, too, need little moisture, and should be protected from heavy rains. If the pots stood on a moist bottom, that would be enough.

Violets.—We took up a lot of Neapolitan Violets, Czar, and other kinds, and placed them in rich, fresh soil in a cold pit under glass. We would have done this sooner, but during the hot weather, and our great shortness of water, they were much infested with the red spider, even though to keep them alive we shaded them with evergreen boughs. We found out that the spider did less harm where green spruce branches were used for shading. What with our pickings, syringings, and the rain and the cool nights, the plants that had scarcely a healthy leaf are now clothed with green foliage, and are well studded with bloom buds. In taking up the Neapolitans with good balls every bit of runner was removed, as runners never produce blooms in the current season, and exhaust too much the main stool. This is advisable when room is scarce under glass for other kinds, but is less essential with them, as the runners often produce good flowers. Though it is hardy enough, we always like to have some of the Czar under glass, for though the blossoms are single, they are large, very sweet, and carried on long footstalks, so that the flowers can be used for many combinations without the necessity of twiggings or wiring them. The length of the footstalk alone is a great advantage. In lifting such plants they should be well cleaned previously, and not a single discoloured leaf left. They soon made a return

for the care and the glass protection. A month ago the hardier Violets were plentiful out of doors. The colder weather has made them more scarce.

Eparises and Ericas still in cold pits must have plenty of air, that the latter, especially, may be safe from mildew. They and the more tender greenhouse plants will be better grouped on the stage of the greenhouse, for they can have plenty of air without noduly lowering the temperature, and much more direct light than they can have in a pit with the light chiefly above them. The more tender greenhouse plants, though having plenty of air, should not stand in a keen draught. Cicerarias and herbaceous Calceolarias, provided they have plenty of air and are safe from frost, cannot well be kept too cool and moist. Were this matter better attended to insect-covered plants would be more rarely seen, and scores of pounds saved in the matter of tobacco-smoking. Even in our plant stoves we should proportion our heat somewhat to light. Many plants will enjoy now comparative rest. Begonias, Eranthemums, and Justicias in full bloom or coming to it, will relish weak manure water. Ferns should never be quite dry, and when growing freely should be kept moist. Such showy plants as Poinsettia pulcherrima, and such useful plants as Euphorbia jacquiniiflora will set their bloom-buds better, and bloom better afterwards if from the end of October or the beginning of November they are kept dryish and a little cooler for a few weeks. When more moisture and heat are given the flowering will be better.—R. F.

TRADE CATALOGUE RECEIVED.

William Chater, Saffron Walden.—*Catalogue of Hollyhocks and Roses.*

TO CORRESPONDENTS.

* * * We request that no one will write privately to any of the correspondents of the "Journal of Horticulture, Cottage Gardener, and Country Gentleman." By doing so they are subjected to unjustifiable trouble and expense. All communications should therefore be addressed *solely* to *The Editors of the Journal of Horticulture, &c., 171, Fleet Street, London, E.C.*

We also request that correspondents will not mix up on the same sheet questions relating to Gardening and those on Poultry and Bee subjects, if they expect to get them answered promptly and conveniently, but write them on separate communications. Also never to send more than two or three questions at once.

N.B.—Many questions must remain unanswered until next week.

Books (*An Amateur*).—"The Vine Manual;" you can have it free by post if you enclose thirty-two postage stamps with your address to our office. (*A. McKillop*).—No new edition of the "Cottage Gardeners' Dictionary" is probable. You can have it from our office, including the Supplement, if you enclose 7s. 2d with your address.

Advice (*A Gardener*).—What next and next? "My master orders me in a bulging way to clean his boots and buckle on his straps and spurs, especially when the groom is out. The place is good, I do not want to leave. I should not so much mind about the boots, &c., if asked civilly, &c. What should I do?" How can anyone advise you better than yourself? We know some good gardeners now who cleaned boots and fire-irons too, and took out ashes in their first place. They found, however, as they progressed, that if they were to do much credit to themselves in gardening they must get out of the way of being general helper to Mary the housemaid, Molly the cook, and John the stable man, and they did so by moving to a place where the garden became their special charge. A man who would rise must be obliging; but, as a general rule, where a gardener and a groom are kept, it will not ultimately be to the advantage of employer and employed that the gardener should be called upon to perform the duties of a valet or a groom. If we were to judge from composition and penmanship, we should say you are more likely to distinguish yourself by making one line or employment the subject of your study and consideration. Still there are many comfortable well-paid situations where one of the chief requisites is the being "generally useful." If that is distasteful, then, as a gardener, you should engage that your duties are to be confined to the garden. We do not see how you can make much alteration in your present place, unless you brought extra prudence and courteous determination to your aid. How is it that you are always so handy for the strapping and buckling business? If the house and stables are not quite close to the garden, almost in it, you need not be quite so near at hand. This we say, because we have known some men grumble at being asked to do to this and that, and yet would place themselves in the way so as to be seen and asked to do what they pretended they did not like. Be assured there is no such thing as having all the sweets and none of the bitter in any position. The hanging about halls and stairways in gentlemen's places has ruined many a young man that otherwise would have been a good gardener. The employer who has many servants will be best served if each servant has his distinctive duties, because then the servant must pay more attention to his separate duties.—F.

FEANS (*Filices*).—To help you to identify species, Hooker's "Synopsis

Filicum" will be best. This "Species Filicum" contains only a select few.

SILVER SAND (*C. G. S.*).—This consists of very fine crystals of nearly pure silica. It may be usually purchased of florists. It is dug out chiefly from pits near Reigate, in Surrey. The grey drift sand obtainable from the shallows of rivers is equally good for potting purposes.

TEMPERATURE ON THE CHRISTMAS EVE OF 1830 (*R. E. Ashford*).—At Chiswick the thermometer fell to 4° on December 24th, 1830, and on December 28th to 1° below zero; but in many places the temperature was much lower—for example, at Chatsworth—12°, at Highfield House—13° 8', at Saffron Walden—12°. It was not only the intensity, but also the duration of the frost that was remarkable.

ABNORMAL GROWTH OF STELLA GERANIUM.—Two plants of the above Geranium have put forth a crown and leaves from the centre of the withered flower-truss. Both plants are this year's cuttings. I should be glad to know if any of your correspondents have observed a similar occurrence, and if it is usual.—G. PIM.

GERANIUMS IN POTS (*Agnes*).—The plants being from cuttings put in this spring or last autumn, and grown in pots for late bloom, will not require pruning now, as they will for some time afford fine trusses of flowers; at least, have some such as you name, and we expect them to continue flowering the greater part of the winter. In February we shall cut them well in, and grow them on for summer flowering. There is no cause why they should not flower finely next season.

EVERGREEN TRAILER IN INTERMEDIATE STOVE (*Thos. W.*).—For covering a low wall in an intermediate stove, we know of but one suitable plant—viz., *Ficus repens*, and it clings to any substance with the tenacity of Ivy. It is of free growth and very neat.

SOIL FOR SWEET-SCENTED VERBENA (*Young Gardener, Dublin*).—Two parts of common garden soil mixed with one part leaf mould, or the bottom of your wood-stack. The soil beneath the stack is not peat, but nearer in composition to leaf mould—that is, leaves thoroughly decayed and friable.

VINES FRUITING IN POTS (*Inquirer*).—As you intend fruiting them in pots two or three years consecutively, we should at once place the Black Hamburgh in a pot 18 inches in diameter, and prune it to a length of 6 feet; but we think it would be of little value for future years' bearing unless you are content to take no more than half a dozen bunches from it, and grow it in a house, not starting the Vine into growth before March. Place the Royal Muscadine in a 15-inch pot, and cut it back half its length. Two bunches would be quite enough to take from it next season. In potting be careful not to injure the roots, but loosen the sides of the ball. Provide good drainage, and cover it with about an inch thick of half-inch bones. You will need to give top-dressings of rich compost, and afford liquid manure when the Vines are in free growth. Let the Vines make more shoots than are wanted for bearing, and allow each an extension of rod of about 3 feet. The shoots not bearing next season will give vigour to the plants and aid in perfecting the crop, whilst they will be better suited for bearing another year than those fruiting next season.

PRUNING VINES (*C. N. B.*).—When the leaves have fallen, or by the middle of December, prune them, the side shoots to two eyes, and that will dispose of all the laterals. If the Vines have rods in addition to side shoots, cut them to 3 feet if strong, or if only moderately strong to half that length. We imagine what you term laterals are the side shoots or spurs.

VINE PLANTING (*J. R. G.*).—Plant the Vines now.

VINE ON OPEN WALL (*R. T. S.*).—You would treat your Vine more safely if, instead of removing it, you placed glass over it where it stands; then you would be sure of a well-ripened crop. Of course, you could remove it by carefully lifting it now, and planting it where it would be under glass, but as it has been planted ten years, you would require to lift it with great care, and then, perhaps, you would have a great return from it for a year or two. A cheap fixed lean-to roof over it where it is, would be the surest as respects returns.

VINE-ROOTS DYING (*J. W.*).—We can assign no reason for the roots of some of the young Vines dying, whilst others are so healthy.

REPOTTING A DICKSONIA (*Idem*).—A Dicksonia, if fresh top-dressed, may remain some years in the same pot; but it will be all the better if the drainage be seen to, and the most exhausted soil removed.

POTATOES AND MANGOLD WURTZEL (*H. R.*).—As you have but one field, and wish to grow no other crops than the abovesaid, your best plan will be to divide the field into two parts, and on the part which has borne Potatoes let Mangold Wurtzel be grown the next year, and vice versa. As you have a good supply of manure, you need not fear having deteriorated crops if you thus crop alternately.

KIDNEY BEAN CULTURE (*A Subscriber*).—We do not see in what way we can improve on your system of cultivating the Scarlet Runner Bean; but we should sow by the first week in May in rows 6 feet apart, with the beans about 6 inches apart in the rows. The ground intended for them should be well and deeply dug or trenched now, giving a liberal dressing of manure. In summer they should be well supplied with water and liquid manure in dry hot weather. We like them staked, but you may have them dwarf by repeatedly stopping them at a foot high. Make another sowing at the end of May. In our "Kitchen Garden Manual," which you can have by post if you enclose five postage stamps with your address, you will find full details.

FRUIT TREES (*A Cottage Gardener*).—You may grow the Black Hamburgh or Royal Muscadine Grapes in a ground viney, either on an east or west wall, but they would do much better in an open but sheltered situation—indeed, it would be a waste of wall to no practical purpose; besides, whichever wall you were to have, the ground viney against it would lose the sun's rays one-half the day, whilst in an open situation it would have the full benefit of the sun. As regards the fruit border, you may plant the Roses 6 feet from the walk, or 11 feet from the wall, but as you wish for fruit we would not do so, but at that distance from the wall we would have a wire put down a foot high, and 3 feet from that a row of bush or pyramid Pear and Plum trees, and 2 feet from that again another wire at the same height as the other. Both the wires we would use for Apple trees trained as double cordons. They may be planted 12 feet apart, and the pyramids or bushes 6 feet apart. You will have 5 feet left

between the second line of cordons and the wall, and that you must not cover with fruit trees, though there would be no objection to a row of Strawberries at 3 feet from the wall. Three good sorts are Sir Joseph Paxton, Keen's Seedling, and if you want a very early one, Black Prince. Unless you procure plants in pots, by planting ordinary runners now, you would not have much prospect of fruit next year—indeed, we would not plant before the middle of February. "Fruit Gardening for the Many" will suit you. It may be had post free from our office for five postage stamps.

HEADING-BACK NEWLY-PLANTED PLUM TREES (Inquirer).—In all cases we advise that newly-planted trees should be headed-back, but as a rule we would confine the operation to the central parts, or where more shoots are required for covering the space. The heading-back may be carried too far, and when a tree has good roots it is not necessary; but if the shoots are thin it is necessary to cut back, so as to secure the requisite number of shoots at the required part. We have seen shortening the central shoots only practised with good success.

PREPARING GROUND FOR POTATO PLANTING (N. C. H.).—Dig the ground to the plow, and throw it up as roughly as possible for the winter, giving whatever manure is required. In digging see that all grass, weeds, &c. are put at the bottom of the trenches. In February turn the ground with a fork, picking out any root-weeds, as Couch-grass, Dock, and Dandelion, and clear them off. If no manure is given at the first digging it should be spaded at the second digging; but whilst at the first digging the manure may be used in a fresh state, at the second it ought to be partially decayed, or what may be termed short, so as to dig in well when spaded on the surface. For a light soil Lapstone and Early Oxford Potatoes are excellent.

PREPARING MANURE (Idem).—We would free the stable litter of the short dung, and place it in the piggery until it became thoroughly wet, then we would remove it to a heap and let it remain until quite rotted—that is, until it could be dug in with a spade. It would be better, however, to take it direct from the piggery to the ground and at once dig it in, but in some cases this is impracticable. Dung usually takes six or eight weeks to become fit to be dug in with the spade, and then it requires to be turned over and wetted twice or thrice. Night soil is a capital manure. It may be mixed with an equal quantity of dry soil, and may be used fresh. A dressing an inch thick is not too much at this season, or half that in spring. Johnson's "Science and Practice of Gardening" contains what you require. It may be had at our office for 3s, or free by post for 3s. 4d.

CANKER (C. R.).—It is not caused by frost, and to remove the bark would kill the trees. If the Apple and Pear trees are young, the canker may be caused by the roots descending into an ungenial subsoil. Removing those roots, and keeping the surface mulched, may check the disease.

PEACH-HOUSE VENTILATION (New Forest).—We should be quite satisfied with your ventilation, but a small triangular opening at each end would be an improvement—say a triangle of from 24 to 31 inches on two sides, with a base 1 foot or so in length. Three or four openings in the back wall, near the bottom communicating with the open shed behind, would also be desirable—say 2 feet long by 12 inches wide. These would be advantages, but with early air-giving we would be content with the present ventilation.

PYRAMID APPLE AND PEAR TREES FOR NORTH-WEST OF ENGLAND (W. N.).—*Dessert Apples:* Early Red Margaret, Kerry Pippin, Cellini, Cockle Pippin, Margil, Nonesuch, Sykehouse Russet, Braddock's Nonpareil, Cox's Orange Pippin, Searlet Nonpareil, Adam's Pearmain, and Wyken Pippin. *Kitchen Apples:* Keswick Codlin, Lord Suffield, Cox's Pomonio, Afriston, Bedfordshire Foundling, Northern Greening, Dumelow's Seedling, Bleenheim Pippin, Hawthornden, Winter Majetin, Norfolk Bearer, and Rymor. *Dessert Pears:* Bergamotte Esperen, Beurre d'Amant, Louise Giffard, Beurre Hardy, Comte de Lamy, Alexandre Lambert, Louis Bonne de Jersey, Williams's Bon Chretien, Zephrin Gregoire, Ne Plus Meuris, Beurre Diez, and Jean de Witte or Glou Morceau. *Baking or Stewing:* Catillac and Verulam.

DATURA STRAFOLENS (Idem).—That is the name of the plant you describe. We cannot account for its flagging, except from its not being sufficiently supplied with water, or you may have destroyed its roots by an overdose of liquid manure. Your treatment must be good for the plant to bloom so well, and we do not perceive in what you used advice.

GLOU MORCEAU PEAR (W. H. H.).—It is a hybrid name, *GloU* is Flemish, and synonymous with our word *daisy*; *Morceau*, a morsel, is French; so that in entire English the name is the "Dainty-morsel Pear."

BOVINA POTATO (C. P.).—You will see the information you ask for in the notes from those who have grown it published by us.

OVERHANGING TREES (A. C.).—You should first request the owner of the trees to remove the branches which extend from his ground and overhang your garden. If he neglects so doing, then give him a legal written notice that you will cut them off so far as they do overhang your garden. If you do so cut them off, then place the portions removed in your neighbour's ground.

GROUP OF TREES IN PARE PLANTING (J. B.).—We would plant the group in masses—that is to say, at the two ends we would have about a dozen of the pink and the common Horse Chestnut, and in the middle two groups of Purple Beech, consisting of about an equal number of trees; the centre we would have Lime and English Elm, and the divisions between the masses *Pinus austriaca*, *P. Laricio*, and Scotch Fir, all at 12 feet apart. We would then fill up the part where the evergreens are with deciduous shrubs for mid-growth, so as to make them 4 feet apart—Black Thorn, Dentia scabra, Scarlet Dogwood, Ribes sanguinea, Snowberry, Gaelder Rose, and Sweet Briar; and the part planted with deciduous trees we would fill up with evergreen shrubs, as *Berberis Aquifolium*, *B. dulcis*, *B. Darwinii*, Tree Box, Holly, Yew, Laurastans, Evergreen Privet, common Laurel, and Rhododendrons. The spring is the best time for thinning out Larch.

ROYAL HORTICULTURAL SOCIETY.—We have received a very handsome bunch of Achurian Grapes from Mr Wells, of Southend, similar to those shown by him from a ground viney before the Fruit Committee on the 2nd inst., and which received a special certificate. By a slip of the pen they were referred to as Black Hamburgh in our report at page 348.

SELECT CHRYSANTHEMUMS (C. Montgomery).—See reports in another

page. If burnt in sufficient quantity to heat the house the plants would be injured. We cannot name florists' flowers.

BORDER RE-ARRANGING (A Subscriber).—In so narrow a border as 4 feet, we do not see what shrubs you can have except against the wall, and in addition to *Pyracantha* and *Pyrus japonica* which you name, we would advise *Berberis Darwinii*, *Cotoneaster Simonsii*, *C. microphylla*, *Forsythia suspensa*, and *Lignstrum japonicum*. Two feet from the wall we would have a row of Roses, and then perennials in front, re-arranging and planting those you have, or you might keep the space for annual hedging plants, but these you could arrange in beds on the lawn. We would stop up all the shrubs in the border, and trench the ground well before planting, giving a good dressing of manure. The shrubs should be planted 4 feet apart, and nailed to the wall.

ROSES—L'ENFANT TROUVÉ (C. W. D.).—*L'Enfant Trouvé* is very like *Elise Sauvage*, but has no synonyms. It will be found in the catalogue of Mr. Cranston, King's Acers, Hereford, and Messrs. Paul & Son, Cheshunt. It is not so hardy or so free-flowering as *Gloire de Dijon*, still in many situations it is a desirable Rose, but in general requires the protection of a wall. It is a useful Rose for pot culture, for spring forcing, though among the yellow Tea Roses for forcing, there is none much better than the old *Vicomtesse de Cazes* and *La Boule d'Or*. *Louise de Savoie* and *Souverain d'un Ami* are also especially good Teas for pot culture.

PYRAMID APPLE AND PEAR TREES (A. W.).—The soil is wholly unsuitable for Apples and Pears. Take it out and replace it with good strong loam. *Dessert Apples:* Red Astrachan, Kerry Pippin, Cellini, Sykehouse Russet, Cox's Orange Pippin, Cockle Pippin, orvunstein, and Searlet Nonpareil. *Pears:* Beurre Giffard, Williams's Bon Chretien, Comte de Lamy, Alexandre Lambert, Louise Bonne de Jersey, Zephrin Gregoire, and Bergamotte E-perou. A good winter Pear for a west wall is *Glou Morceau*.

POTATOES SPROUTING (Negro Novis).—The Early Rose and Mona's Pride now sprouting we would keep in the light if we could, and as cool and dry as possible, and if they are more sprouted than a quarter of an inch, it would be well to rub the sprouts off. The beginning of February is quite early enough for them to begin sprouting; but this year our Potatoes, especially the early sorts, are sprouting, no doubt owing to the drought of the past summer stopping their growth and inducing premature ripening. The cooler they are kept, if safe from frost, the better. If you give them to the pigs it is likely you will not receive for planting any that have not had the first sprouts removed. Those which have not sprouted are to be preferred.

AIR IN HOT WATER PIPES (B. A.).—You had better have an air-pipe in the return-pipe as well. With an air-pipe on the top flow-pipe, and the supply-pipe 2 feet above the flow-pipes, we cannot conceive how the water does not heat and circulate in these upper flow-pipes, except that the air-pipe is not at the highest point, or that the air-pipe is clogged or closed up. Two years ago we had a pit with pipes rising about 8 inches to the farther end, with an air-pipe there going outside, and then turned downwards to keep dust out, but some earth-bees had taken up their abode in it, and no heating nor circulation could be obtained until the small air-pipe had been cleaned out. We think this is most likely the reason. We could hardly assign any other cause, without knowing all about the levels of the pipes.

HEATING A CONSERVATORY (L. G. M.).—If the house, 17 feet high, has much glass at the sides, you had better have three pipes all round beneath the pathways instead of two. As these pathways are to be of ornamental tiles, there should be ornamental gratings to let the heated air freely up. A tubular boiler fed from the top is, perhaps, the most easily managed. A No. 2 of Messrs. Weeks's, costing from £5 to £7, would suit you. For our selves we would not look askance on a good saddle-back as that of Jones, 20 inches in height, 18 wide, and 24 long, costing about £6. For such a position we would prefer the pipes being jointed with iron flings and sal ammoniac.

GLAZING A CONSERVATORY (Reader).—We would in your case, if the glazing at the sides is done in the usual way, and the glass held firmly with putty, have the roof glazed with small laps—say of one-eighth of an inch. The plan you propose of having the glass put edge to edge without laps would answer very well, if by grooves deeper than the glass, and using yielding material for packing, you gave room for the glass to expand and contract laterally. If the glass is put rather firmly between rebate and rebate, or if the putty becomes so hard as to prevent its expanding at the sides, the closer and nearer the edges of the squares fit each other, the greater the danger of cracking from expansion. You will be safer by not having the glass quite close to the rebate on each side; still, even that help will not prevent the glass chipping at the edges. This expansion provided for at the sides, there is then little danger of chipping, and if the roof is not flat there will be no danger of drip.

NAMES OF FRUIT (A. Walker).—1, Betty Geeson; 2, Bull's Golden Reinette; 3, Figue de Naples; 4, Urbaniste. (A Constant Reader).—*Apples:* Springrove Codlin; 2, Piles Bussel; 3, Lamb Abbey Pearmain; 4, Christie's Pippin; 5, Huothou; 6, Russet Pearmain; 7, Kingston Black; 8, Golueu Reinette; 9, Casseler Reinette. *Pears:* 1, Brughnam; 2, Van Mons Leon Leclerc; 4, Passe Colmar. (H. C. Tonbridge).—1, Beurre Deroumeau; 2, Delanoy; 3, Comte de Lamy; 4, Old Colmar; 5, Winter Nohis; 6, Glou Morceau; 7, Princess Charlotte. (W. R.).—1, Braddock's Nonpareil; 2, Stormer Pippin; 3, Winter Hawthornden; 4, Cox's Orange Pippin; 5, Stead's Kernel; 6, Normanton Wonder. (A Constant Reader, J. W. M.).—1, Pearson's Plate; 3, Couri-Pendur-Flat; 4, Marmalade Pippin; 7, Braddock's Nonpareil; 9, Like Cox's Orange Pippin; 10, Api petit; 11, Carel's Seedling; 12, Broad-eyed Pippin; 13, Selwood's Reinette. (Centurion).—1, Kentish Codlin; 2, Reinette Blanche d'Espagne; 4, English Codlin; 5, Duchesse d'Angoulême; 6, Lemon Pippin; 8, Bedfordshire Foundling. (Cavendish Richardson).—1, Barcelona Pearmain; 5, White Nonpareil; 16, Court of Wick; 31, Sykehouse Russet. (A. D. R.).—When we omit naming some of the specimens sent, it is because we do not identify them. We knew your No. 2 to be *Duoyennu Comice*, but did not recognise No. 1. If you will send another specimen we will endeavour to name it.

NAMES OF PLANTS (Old Subscriber).—We cannot identify plants from their leaves only. (A. L. Richmond).—1, *Achimum Capillus-Veneris*; 2, *Lactuca dilatata*; 3, *Pteris serrulata*; 5, *Ruscus Hypoglossum*. (A. Y.).—We cannot undertake to name florists' flowers, nor plants from mere leaves, and you have sent both; 3, is *Euonymus europaeus*.

POULTRY, BEE, AND PIGEON CHRONICLE.

AWARDS—TRIMMING.

I THINK Mr. Hewitt replies to my observations rather in a hurry, or at least without my remarks before him; he has, at all events, altogether mistaken the drift of what I have written; and as no one knows better than he does that friendly discussion is the way to elicit truth and weed the errors out, I will return, with your permission, to his comments of last week on my remarks in a previous number.

He speaks only, for instance, of the difficulty of placing in order of merit all the "highly commended" pens; but if he read my remarks again he will see that my chief suggestion was for a distinct award to be given to all pens, and to those only which in an ordinary competition, or by intrinsic merit, deserved a prize. That was the point on which I laid stress, and on which I wished to ask his opinion, and on this he says nothing. The award I suggested was "very highly commended," but a perusal of the New York schedule has suggested to me that "diploma" would be shorter and better. I admit the force of what Mr. Hewitt urges in the one case, but he will not deny that while strict order of merit may present difficulties, as I admitted, by giving up that order in the simple commendations, his experienced eye would readily pick out the deserving pens at least; and my object was not so much to have in strict order the commended pens as by some systematised award, costing nothing, between prizes and commendations, to show by the prize list alone the character of a competition. In this way a number of diplomas in a class would show that the prizes were hardly won against formidable competitors. To attain this object they should not be given to merely good pens, but solely to such as are really worthy of a prize.

I again commend this matter to consideration, but this time more especially to committees. The cards might read thus: "HONORARY DIPLOMA, to certify that in an ordinary competition this pen would be worthy of a prize." They ought not to be too freely given; but rightly used, would not only give valuable information, but would make a show popular, please exhibitors, and place shows which cannot afford four prizes more on a level with the larger ones.

While I think this matter might be of great use, I am not spending "money" upon it, nor did I "admit," as Mr. Hewitt too hastily says, that I spent "time and money fruitlessly" a year ago upon trimming. I simply said my application to "Birmingham" had been made in vain. That show is never won over to anything all at once, and I do not despair even of Birmingham by-and-by; but with the general results of my labour I am abundantly satisfied, and the best proof of it is that I am yet, as opportunity offers, spending more. Briefly, I may say that bad cases of plucking are now at least passed by in about half the number of instances, whilst formerly they nearly always won. I may also add that about two-thirds of the schedules now contain a trimming clause, whilst previous to the discussion not one in ten contained such a thing. Bristol was one of the first shows to adopt one, and was copied by London, whilst some few (as Ipswich) have adopted Mr. Hewitt's own proposal to disqualify all the pens of an offender. Such are the more tangible results, but other fruits are no less real because less visible. There has been a growth in the fancy to some small extent of a "conscience" on the subject. I could name a "reverend" sinner whom the discussion led to abandon the practice, and a well-known Game Bantam breeder, formerly a notorious offender in the very worst form, who showed his birds, I believe, for the first time after the discussion, "without trimming a feather, sir;" though I am glad to add it was not his last appearance in that character. Better still, the real "fanciers" have begun more and more to find each other out, and to trust each other, while they have learnt to regard the cheats with a deep and pitiful scorn which was hardly known formerly, and which, I trust, if it go on, will yet make it apparent that treachery, though it may win, does not pay. The fancy "tailor" may still take his "borrowed rags," and by shameless plucking make them into a first-prize Brahma; but after long months of work that has been little apparent, and I am free to confess has given me many disappointments, I really do believe the time is at hand when he shall find that prizes so won are no real gain, but simply bring him the contempt he deserves. I never worked at this matter, despite of appearances, with more hope than I do now; and even

Mr. Hewitt will, I think, admit that there is some difference, however small, between the present time and two years ago.

It is a good opportunity to say that all who hate trimming may do their part entirely independently of committees or judging. Make the sinners feel you despise them; and as a man who can cheat in one way will do so in another, never deal with a known trimmer. The worst, or one of the worst of them, I know, is also a man who sells eggs which hardly ever hatch. If all who really do hate the fraud would show it, we should soon have the fancy cleared of those who do not really belong to it, and have no real love for it, but are in good truth only its scum.

Finally, I think Mr. Hewitt has, I am sure not knowingly, done injustice in saying that some of the very first on the list of protestors against trimming proved among the very earliest to be "caught for actually sewing through cocks' combs to keep them upright." Every protestor, as I was quite prepared to find, has not proved immaculate; and it must also be remembered that many exhibitors are in the hands of their men, and know little of their fowls themselves. Still, as a matter of fact, I do not remember any protestor having been guilty of the enormity referred to, and I should be glad if Mr. Hewitt could give the instances. The only name I remember is that of one who stained the wing of his Cochon cock, and in this case it was I myself who publicly stated him to be a "protestant." "One" is not "some," and as I know at least the main body of the signatories to have been honest in the matter, I feel I am only defending them in asking Mr. Hewitt to mention the "some" cases he refers to. My belief is he has mixed up in his mind my identification of the sinner in question with some other case; if it is thus, I feel sure no one will feel greater pleasure than he that it should be so. The object of neither of us is to injure private character, and as what took place between us some time since I am quite willing to confess enlightened me somewhat as to the difficulties of a judge, so I am sure he understands me too well now to put a false construction on my defence of honourable men.

He has a passing remark on judging, by the way, which is worth its weight in gold, but which I must leave for a future occasion.—L. WRIGHT.

INCREASE OF NUMBERS OF PRIZES—
JUDGING.

AMONG the many obligations due from all fanciers of poultry to Mr. Hewitt, must be reckoned the fact that he is not unwilling at the proper time to speak out, or to let us know what he thinks upon the various questions that arise in the poultry world. We are, indeed, fortunate to have a judge among us whose unswerving integrity is only equalled by his capacity for his peculiar work, while at the same time he can put his thoughts on paper in a manner calculated to adorn the pages of any journal to which he is disposed to contribute.

When I read the suggestion that all highly commended pens should be placed in order of merit, I thought that no judge would ever consent to add such a burden to labours which at present are by no means light, and it is evident that Mr. Hewitt, for one, will not accept the proposal. The gain to the public, in fact, would not in any way compensate for the additional trouble imposed upon the judges. And yet I am glad the matter has been mooted, because Mr. Hewitt has now told us what he thinks the best rule with regard to the distribution of prizes—that it would be well if possible to have four prizes in every class instead of two only, or at most three. This suggestion I regard as of great importance. Let me give an instance from my own experience. I had intended to have exhibited both at Southampton and at Ipswich. Looking over the schedules of prizes offered, I find that there are two only in the classes in which I should exhibit, and although cups are held out to those who reach the very top of the tree, yet the prospect of a cup seems too remote to induce me to send my birds. Had there, however, been third or fourth prizes offered, I should at once decide to exhibit, for even a fourth prize is a higher honour than a highly commended, and, moreover, it helps to pay the expenses.

And now let me congratulate the Committee of the Crystal Palace Show on the improvement they have made in their prize list this time compared with the one of January last. It will be long before I shall forget the havoc that was made on the last occasion in the Dorking class among birds which had done great things when shown before, but which were then

compelled to be content with a high commendation, or a commendation only. There was then but one class for Coloured hens and pullets, and one for cocks of all ages. Now there are three classes for Coloured birds, three for Silver-Grey, and one for White. If the Committee next year will take Mr. Hewitt's hint, and give four prizes in each class, they will probably increase the entries, and so improve the show. I trust, too, that they will find something better than those execrating wire pens—with wire I mean on three or four sides—in which every other minute the bird's tail is passing through or rubbing against the wire, so that a show of three or four days' duration is sufficient seriously to mar, if not altogether to destroy for a time, the exhibition prospects of many a fine bird.—E. M. E. A.

TO SOUTHAMPTON SHOW.

"Unto Southampton do we shift our scene."—(Shakespeare's
Henry V., Act 2.)

No. 1.

I propose to write two papers, the one to Southampton Show, the other at Southampton Show; the first dealing with generalities, the second with the specialities of the Exhibition.

Hampshire, Hants, or Southampton used to puzzle and annoy me when, not exactly yesterday, I was learning my English counties. Shropshire or Salop was bad enough to remember, but at least they both began with an S; but Hampshire, Hants, or Southampton was intolerable. What had Southampton to do with Hampshire? Then, soon after, I learned to connect Southampton with travelling to the far east, and this did not increase my love much, as friends, boyhood's friends, with whom I walked in our playground, the precinct of an old cathedral, "twinning arms round each other's necks as only school-boys can," to quote Dr. John Brown, had gone from Southampton, and fought and died in the Sikh war in the far India. So I had little love for the place, but I knew it not, and, as it proved, because I knew it not; and now, thanks to poultry, I have made the acquaintance of Southampton.

Leaving Wiltshire on Monday week with a mist around me was not encouraging, but unexpectedly meeting at my station a brother parson and brother poultry fancier put a brighter aspect upon affairs, and much mended matters. The day was indeed dull and dreary, but then could we not talk pleasant poultry talk, and then talk parson talk proper, and then hark back to poultry again? We did this on Monday, and though the mist hung over us we minded it not. Westbury White Horse stood out shaggy with mist, looking like a rough Shetland pony. Curious that we should have in Wiltshire three white horses cut on the downs—that on Cherrel Down, near Calne, this at Westbury, and the one the boys cut out at Marlborough, all better shaped than the original and far-famed one in the Vale of White Horse in Berks. Talk, talk, and no view until we come in sight of Salisbury Cathedral, and a long and good view of it we had as the train wound slowly out of the station. Does any reader know that most genial and kindly book of the American blacksmith, "A Walk from London to Land's End and Back"? If he does, he will perhaps remember Elihu Burritt's beautiful words about Salisbury Cathedral spire; but all will not have read the book, so I will quote them. Catching a distant view of it, he says, "Beyond, like a long delicately tapering finger, ringed at the middle joint, the spire of Salisbury Cathedral points upward, pushing its silver nail into the lower clouds. For six times the life-length of the American Republic that finger has been uplifted in sky, cloud, and storm. In the most tempestuous years of English history, in John's day, and Stephen's, and Cromwell's, it towered with steady poise into the still blue bosom of the sky, like a petrified human prayer, lifting the cross nearer heaven than it was ever raised by other shaft on this proud island." As I passed, and gazed and admired, I thought of these eloquent and graphic words. No one more noticeable thing until Romsey brought to mind Lord Palmerston's manly English character and career. Then on further, and amid red brick and blue slate, and a gleam of masts in the docks, I am at Southampton Station.

And now, to use Shakespeare's words (and he almost always will supply a suitable motto),

"Unto Southampton do we shift our scene."

Nowhere do old and new stand out in more direct and abrupt contrast than in Southampton. The town is very old and very new, but there exists a divider in the Bar Gate, an old gateway not unlike, but much superior to, Temple Bar. In speaking in Southampton it is "Above Bar" and "Below Bar"—below Bar all old, above Bar all new; below Bar trade, above Bar

private residences; below Bar much crowding of houses, above Bar all width of streets and spacious parks or park-like squares. In the old part crop out portions of the old stone walls mixed, and mingled, and built in to red brick houses, like warts on a hand, with this difference, that the warts are far prettier than the hand. In some parts of the Below Bar there are remains of ancient towers and military architecture. Above Bar is my temporary home. By the way, I always feel that a friend's house in a strange place is my home there, so different the feeling when in lodgings or at an inn; and never did I find kinder friends or feel more thoroughly at home than at Southampton.

The poultry show will not be opened until Tuesday afternoon, so I stroll about; and further Above Bar come upon one park, or, more properly speaking, large park-like square, called "Watts's Park," because a marble statue of the good little non-conformist Isaac Watts, D.D., a native of Southampton, stands in its centre. There, in gown and bands, and with hymn-book in his hand, stands he who was the best writer of children's hymns this country ever produced. It is said that on this spot, overlooking Southampton Water, and viewing the beautiful country beyond, Watts wrote the lines—

"Could I but stand where Moses stood,
And view the prospect o'er!"

and it is for this reason that the statue is there placed. On the pedestal beneath the statue are four bas-reliefs, the best a group of little children in the dress of the day, and in their midst the good little doctor and his hymn-book. Over this group are the suitable and true words, "He gave to lisping infancy its earliest and purest lessons." In another such park is a statue of Lord Palmerston, and in another one of some worthy Mayor of former days. Wide are the streets and well-built the houses in the part above Bar. I stroll by the Water, a beautiful long narrow estuary, with the New Forest beyond it, and I stand at the door of the Carlton Hall, which, I am told, is the largest room in Southampton, but no admittance yet; but of it and of its contents No. 2 shall, all being well, tell next week.—WILTSHIRE RECTOR.

POULTRY SHOW REPORTS.

First let me altogether disclaim any intention of inflicting a wound on "WILTSHIRE RECTOR" deep enough to require a plaister. The utmost I wished was to give him just the gentlest and friendliest dig in the ribs, and that, too, with no more dangerous weapon than the stump of my old quill pen.

"WILTSHIRE RECTOR" sets me down as a beginner. Certainly my experience is not so extensive as that of many, but at all events I can claim as long experience as an exhibitor as he can as your correspondent; and in those breeds in which I am most interested I think I know the points of a good bird without having to turn to the pages of the "Standard of Excellence" for information. Let me remind him that I did not ask for information as to what birds *ought to be*, but what they *are* at the particular show which is being reported—how nearly they approach to the perfection demanded by the "Standard." But at the same time it could not but happen that in such reports as I asked for much valuable information would often be obtained incidentally, which would do much towards setting at rest many at-present-debated questions.

"WILTSHIRE RECTOR" instances Mr. Blaketon's articles. I regret to confess that I am absolutely ignorant of Canaries. If I dared, I would say that the prizes seem to be awarded always to the ugliest birds. Nevertheless, I never pass over one of "W. A. B.'s" articles; they are indeed so witty, so much more than readable—so highly amusing. I have looked back to the report upon the Crystal Palace Show referred to by "WILTSHIRE RECTOR," and I perfectly agree with him that it is admirably done, but I entirely disagree with him as to its not going into details. Let "WILTSHIRE RECTOR" read it again. It takes each class separately; it picks out the best birds in each; it points out the characteristics of many of them; it mentions in a way which could not offend the susceptibilities of the most sensitive judge when he does not altogether agree with the decisions; in short, it is just what I have asked for in the reports of our poultry shows, and I hope "WILTSHIRE RECTOR" will take it for his model when he gives us his account of the next Bristol Show, which I trust he will be able to see and to write about, that we may have the pleasure of reading it.

I take it that reports of poultry shows are written for the benefit of poultry fanciers, to whom the much-abused details are

not dry; and therefore they should be different in style from those articles which are intended for beginners and to stimulate the love of our feathered pets. Let these be as elementary as you please, and as attractive as all "WILTSHIRE RECTOR'S" letters are; with which plaister I will leave the subject, after metaphorically shaking hands with "WILTSHIRE RECTOR," and hoping that we may live to meet at some time, perhaps at Birmingham or the Crystal Palace.

I intended to say a word or two upon our "Persian friend's" letter, but I feel that I have already tried your patience, Messrs. Editors, too severely.

Let me, however, ask just one question. I have had a copy of the *American Poultry Bulletin* sent me, with a schedule of the New York Poultry Show. In the schedule I see prizes offered for "White-headed Brazilian Divers," "White Crested Biarritz Ducks," and "Nicaragua Singing Ducks." These names sound very tempting—can you tell me anything about their owners? Are they domesticated or wild birds? And are they known at all in this kingdom? and if so, where are they to be seen or obtained?—SHROPSHIRE RECTOR.

[We published a woodcut and description of the Cayuga, which we believe is the same as the Nicaragua Duck, in the fifth volume of this Journal. Of the other squatics we know nothing.—EDS.]

THE NEW YORK POULTRY SHOW— LEGHORNS.

THIS Show is to commence on December 14th, and remain open till the 22nd. I fear such a long period of confinement will deter many British breeders from competing; but to meet the case as far as possible the Committee have arranged for a grand auction of the foreign birds, which, if of good quality, will be tolerably sure to realise fair prices, especially as they will be well advertised by the Society. The danger of a return voyage will by this means be avoided.

Compared with our English shows the arrangement of prizes seems very curious. Our exhibitors are always complaining they do not get enough in hard cash. Whatever would they say to the American system, which gives as four prizes in all the general classes a bronze medal, diploma, honourable mention, and high commendation respectively? so that the unlucky second may if he please exclaim, "All is lost save honour." Some silver medals, however, are also given, and in many other classes various poultry and Pigeon books form the prizes. For several breeds there are also silver cups varying in value from 10 to 25 dollars; and in particular, there is a cup each, value 25 dollars, for Dark Brahmas, Buffs, Grey Dorkings, and Houdans, to be awarded to the best trio of old fowls with six of their own chickens. A great gold medal, a second gold, and a silver medal are specially provided for the best collections of poultry from over the sea. The most valuable prizes of all, and which are open to English aspirants, are for the best essays on the breeding and management of poultry (prizes 100, 50, and 25 dollars), and for the best plans of poultry buildings (prizes 50, 30, and 20 dollars).

There is a class for Any other variety, but I do not know what is to go in it, for there are separate classes already for about every breed known, including even Creepers, Frizzles, Rumpkins, and Russians!

As a subscriber wanted to know the other day what Leghorns were, I may as well say it is a very favorite American breed just now coming over to this country. The most esteemed colour is white with, I believe, yellow legs and single combs; but many prefer a rose comb, which has generally pink or white legs. To judge by the engraving in my possession, no fowl could show stronger appearance of a Spanish origin, but the yellow leg makes it hard to say what cross has been employed. The rose-combed and white-legged breed is in my opinion crossed with the White Dorking; and that some cross has been employed is nearly proved by the fact that the other recognised colours are brown (with Grey Dorking?) and Dominique, which answers to what we call Cuckoo, the American Dominique fowl resembling our Cuckoo Dorking, or rather Scotch Grey. Be this as it may, the breed is fast becoming a favourite in the States, is hardy and a good layer, and is said by many to be more profitable than any other variety known in America. A very good pen of White Leghorns, I may as well say, was shown by Mr. Tegetmeier last week at Southampton, and I quite expect the breed will soon be well known in the Variety class at our shows.

A lot of odds and ends follow the poultry in the New York

schedule. Everything that ever was, is, or can be petted seems to be put down for a class. I really do not exaggerate, for they range from deer and ponies down to white mice. There is no end of classes for Squirrels; and such things as Ferrets, Minks, Marmots, Coons, Opossums, Chipmunks (what is this little beast?) and Spotted Gophers, all find a place. Being of an inquiring mind, I really envy those who can afford to visit the New York Show.

I will only add that I shall be happy to forward schedules to all who apply for them.—L. WRIGHT.

[The Leghorns shown at Southampton are noticed in our report to-day. In addition we add the following from *Moore's Rural New Yorker*. "The White Leghorns are said to be a hardy breed, and of medium size, of quiet disposition, persistent layers, of a pure white colour. Their legs and skin are yellow. The cocks have large single combs, which should be perfectly erect; full wattles, and large cream or white ear-lobes, extending sometimes upon their face, and not dissimilar to those of the White-faced Black Spanish. The hens have usually large combs, frequently seen to lop over like those of the Spanish hen. The young are easy to rear, feathering up soon. They are reputed to be excellent winter layers."—EDS.]

PURCHASED EGGS.

I AM an amateur breeder of Dorking fowls, and therefore desirous of improving my stock, and write to detail my experience in the purchase of eggs for breeding purposes; further, to inquire of my brother amateurs and your readers whether they have experienced similar disappointments. Four years since I procured a sitting of eggs from an eminent breeder, for which I paid, with carriage, 22s. 6d.; these brought no produce. Two years since I obtained, through a friend, a sitting from a great prizetaker in another county; these eggs all proved bad. This last season I obtained my eggs elsewhere—the result is two chickens only, which are neither Dorkings nor any other breed. Thus, I have expended nearly £4 in eggs, including carriage, and have two chickens, worth about 3s.—UNFORTUNATE.

SOUTHAMPTON POULTRY SHOW.

THE arrangements of this year's Show were promptly to time, careful, and well regulated. Those of our readers who may never have attended a Southampton show will be pleased to hear that the Carlton Hall, in which the Show is held, is one of the very best rooms that could be desired for the purposes of a poultry show, and the really excellent exhibition pens supplied by Mr. Billett, of High Street, Southampton, which are so large and lofty, left nothing to be desired on that score, even by the most anxious and fastidious amateur of poultry. The improvement as to the number of exhibitors, as well as to the number of pens entered, is a matter for general congratulation, as considerably over a hundred more were exhibited this year as compared with last. Again, as indicative of future success, at this meeting's public luncheon no less than seven silver cups and a silver watch were spontaneously offered by private individuals, altogether irrespective of the customary prizes given by the Southampton Committee, so that the continuance of popularity and success is well guaranteed. We must add to this, that the public attendance this year, the weather proving very favourable, exceeded that in any of the preceding eleven years this Show has been established.

The *Spanish* fowls, though generally somewhat out of high condition, were, as a whole, a very good class indeed; and the *Grey Dorking* classes, both chickens and adults, were far superior to any yet seen at a Southampton show. Mr. Martin's well-known Rose-combed Dorkings were among the prominent winners. *Cochins* were of first-rate quality, though many pens were wholly, or in part, much out of condition. Mr. Cattell's hen in the third-prize pen was one of the best exhibited for many years past, but was, unfortunately, mated to a cock in such indifferent health, as to throw her out of high position altogether. The *Light Brahmas*, as they always are at Southampton, were the glory of the Show, and the Rev. H. Maynard and Mrs. Williamson were entitled to their success in a very severe competition. The whole of these birds, in very extensive classes, proved at a glance how great the care and attention must have been to breed them so truly to feather as they were shown. Though a few pens of very excellent *Hamburghs* were shown, the majority of those competing in these classes were not so good as in former years. A number of pens of very first-class *Game* fowls were exhibited, in which the condition could not be improved, but, on the contrary, not a few others lacked both robust constitution, and, at the same time, purity of feather. A grand pen of adult Black Red Game fowls, shown by Mr. Gibson, ran in very closely for the President's cup, of the value of ten guineas. Except in the case of two or three pens of *Polish* fowls, we confess ourselves to be disappointed, the majority showing rather a falling off in quality than an improvement. A very great feature of the Show,

as might be fully expected in this locality, were the *French fowls*; for Houdans, La Flèche, and Crève-Cœurs were shown of the highest merit, and in numbers quite unprecedented. In the chicken classes for French fowls we cannot recollect so many pens being highly commended, or more deservedly so.

In the "Any other variety" class there was much merit, Black Hamburghs being first, and excellent Malays the second prize birds. In this class we cannot refrain from mentioning a pen of "Leghorns," a variety hitherto not seen in any public exhibition in England. They resemble very closely White Spanish fowls, but, which adds much to their singularity, they are as yellow in the legs and feet as a Malay fowl, and we are told they are as hardy as a Brahma, being also excellent layers. They are a breed introduced recently from America, and appear somewhat likely to be a very useful variety for general purposes in the farmyard, their powers of egg-production being extreme, and the quality of the flesh for table purposes, more especially when roasted, very closely approximating to that of Game fowls. The Game Bantam class was, though large, not so perfect, except the prize birds, as we might reasonably have expected, but the "Any variety of Bantam" class made the most ample amends. Sebrights were numerous and good, and Black Bantams and Light-feathered Japanese Bantams of the highest merit were shown.

To speak of the Aylesbury Ducks in detail would be needless for Mrs. Mary Seamons, of Aylesbury, heading the list with two pens, which would be very coveted in the eyes of any Duck-breeder. In the "Any other variety" class for Ducks twenty-four pens competed, of such quality as is but rarely seen. The Baenos Ayrean Ducks were exceedingly good. The Mandarins and Carolina were shown in exquisite feather, and besides these there were entered some first-class Rouens. We now come to one of the most remarkable features of the whole Show, pen 362, entered by the owner, Mr. F. G. Dalgetty, of Roke Manor, Romsey, as "Paradise Ducks." They were certainly very remarkable, perfectly tame, being, as stated in the catalogue, "bred in New Zealand." They consisted of six birds, apparently three of one kind, a pair of another variety and the odd one still different from either of the others. They were all shown (we had almost said crammed) in one pen, so that much difficulty ensued to those visitors whose desires prompted a close inspection. No one seemed to know anything about them among the numerous visitors present; in fact, the Judge himself candidly admitted "they were quite new to him," the reason, we suppose, they were "very highly commended," though the rule of the Show was distinct, that each pen should be a pair only. They naturally were one of the lions of the Show, but were entered at the reserved price of £1.0.

The *Geese* and *Turkeys* were perfect giants of their kind, and here Mr. Fowler and Mrs. Seamons were the recipients of the prizes in the first-named class, and Mr. Patton and the Rev. J. L. Ridley in that for Turkeys.

The entries in the Selling classes—one class for "single cock of any variety or age," and the other for "a pair of hens or pullets of any breed"—must have proved a most excellent "hit" for the coffers of the Society, as seventy-eight pens competed. In the cock class a Grey Dorking and a Crève-Cœur were the respective winners, and in the class for hens Silver-Grey Dorkings and Partridge-coloured Cochins were successful, among a host of rivals that would certainly have pretty well held their own at the majority of shows.

The *Pheasants* were shown in most excellent plumage, and added much to the beauty of the Exhibition. Strange to say, there was not a single entry in the class for "Ornamental poultry." We would suggest that another year the heading should be for "Ornamental birds of any kind," and we then think the entries would, as at Newcastle-on-Tyne some fifteen or sixteen years back, insure a most comprehensive and attractive entry, forming, too, a very pleasant break in the monotony of a poultry exhibition.

The table of dressed poultry, "trussed but not drawn," proved quite an interesting feature, Mr. Dowsett appearing in the van with fowls of excellent quality and very nicely dressed; some others, much heavier but coarser specimens, being entered against them. These table fowls were a cross between the male Light Brahma and Grey Dorking hen.

In the portion of the Show devoted exclusively to foreign and British birds, a pair of Nomidian Cranes, a really *Buff-coloured* Blackbird, and a most singular Mule, bred between a Bullfinch and common Linnut, were well worthy of attention. A pair of Palliated Jays from Mexico were also among the first ranks of novelties displayed.

Pigeons throughout were excellent, but several attempts at imposition by showing two cocks or two hens instead of a pair, very properly resulted in instant disqualification. The whole of this division of the Show (the Pigeons) occupying the orchestra, was seen to great advantage.

With such a varied amount of attractions, the satisfaction of the visitors was openly and very generally expressed. Although this eleventh Show of the Southampton Society was brought to so very successful an issue, thanks to the management of a thoughtful Committee and the never-relaxing efforts of Mr. Philip Warren, the Honorary Secretary, there is a little matter connected with the next year's prize schedule that admits of improvement. This year the President's silver cup, value ten guineas, is given to the best pen of poultry of any variety. Where so many of the first-prize pens are so nearly perfect, it is a thankless, invidious, and capricious task to adjudge this final

premium; and certainly were this valuable prize given to the exhibitor of the best collection of poultry, it would as surely increase the number of entries as it would improve also the quality of the birds throughout the whole Show. Mr. H. Yardley, of Birmingham, took both the extra cups for poultry and Pigeons.

Mr. Edward Hewitt, of Birmingham, judged the *poultry*; Mr. Esquiland, of London, the *Pigeons*; and Mr. Wilmore, of London, the *Canaries* and *Foreign Cage Birds*.

Further remarks on the Pigeons and a notice of the Canaries and other cage birds, of which a prize list is given beneath, will appear next week.

NORWICH.—*Clear Yellow*.—1 and 2, Moore & Wynne, Northampton. *rhe*, W. Walter, Winchester (2); T. Mann, Camberwell New Road. *he*, Toot & Cleaver, Kettering (2). *c*, E. Lidstone, West Cores; H. Apted, Worsthing; B. Wildsher, Hinchester. *Clear Buff*.—1, Moore & Wynne. *c*, Toot & Cleaver. *rhe*, W. Walter (2); G. Knock, Coventry. *he*, Moore & Wynne. *H. Apted*. *c*, G. E. N. Rawlinson, Gloucester. *H. Apted*. *Marked or Variegated Yellow*.—1, T. Mann. *2*, W. Walter. *rhe*, H. Apted (2). *he*, F. Hodding; H. Apted (2). *c*, T. Mann; Moore & Wynne (2). *Marked or Variegated Buff*.—1, W. Walter. *2*, Moore & Wynne. *rhe*, W. Walter; Moore & Wynne. *he*, T. Mann; H. Apted. *c*, G. E. N. Rawlinson; H. Apted; T. Wildsher. *Any other Variety*.—1 and 2, Moore & Wynne. *rhe*, W. Walter; Moore & Wynne. *he*, W. Walter; Toot & Cleaver; H. Apted. *c*, H. Apted (2).

↑ For the greatest number of points in the Norwich classes—Moore and Wynne, Northampton.

BELGIAN.—*Clear Yellow*.—1, T. Moore, Fareham. *2*, T. N. Harrison. *rhe*, T. Moore; C. Carver, Landport. *Clear Buff*.—1 and *rhe*, O. Nicholson, Landport. *2*, J. N. Harrison. *Variegated or Marked Yellow*.—1 and 2, O. Nicholson. *he*, C. Carver. *c*, Mrs. J. Chinery. *Variegated or Marked Buff*.—1 and 2, O. Nicholson. *c*, J. N. Harrison.

CANARY.—*Golden-angled*.—1, T. Fairbrass, Canterbury. *2*, J. Taylor. *rhe*, H. Ashton, Polefield Hall, Prestwich; J. N. Harrison. *he*, O. Nicholson. *2*, Fairbrass. *Silver-angled*.—1, J. Taylor, Middleborough-Tees. *2*, and *rhe*, O. Nicholson. *he*, J. Taylor; H. Apted; C. J. N. Harrison.

GOLDFINCH MALE.—*Jonque*.—1 and 2, H. Ashton. *he*, J. Baxter, Newcastle-on-Tyne. *Méale*.—1 and 2, H. Ashton. *rhe*, J. Baxter (2). *he*, J. Goodie, Leicester.

CANARY OR MALE (Any other Variety).—1, T. Mann (London Fancy). *2*, H. Ashton (Bullfinch and Goldfinch). *rhe*, E. Lidstone, West Cores (Cinnamon); H. Apted (Cinnamon); H. Ashton (Linnut Mule) (2). *he*, Miss E. Verrier, Brighton (Linnut Mule); J. Baxter (Siskin Mule).

BRITISH BIRDS.—*Bullfinch*.—1, J. W. Harrison. *rhe*, J. Jeans, Marchwood, Southampton. *he*, W. B. Bailey, Furbert; Mrs. Rowe. *Goldfinch*.—1, O. Nicholson. *rhe*, W. Walter. *c*, J. W. Harrison, Great Portland Street, London. *Linnut*.—1, J. Barker. *rhe*, W. Walter. *Siskin*.—1, J. W. Harrison. *he*, W. Walter. *Woodlark*.—1, J. W. Harrison. *he*, W. Walter. *Blackbird*.—1, J. W. Harrison. *Song Thrush*.—1, Mrs. W. Stowe. *rhe*, J. W. Harrison; W. Walter. *Any other Variety*.—1, J. W. Harrison (Nightingale). *2*, A. J. Hubbard (Magpie). *rhe*, J. W. Harrison (Starling); W. Walter (Dove-coloured Blackbird); H. Chamberlain, Bassett, Southampton (Magpie). *c*, J. Summons; W. B. Bailey (Starling).

FOREIGN BIRDS.—*Cockat* (Any variety).—1, C. Simeon, Hursley, Winchester (Longtail). *rhe*, W. B. Bailey, Furbert (Leadbeater). *Parrot* (Any variety).—1, J. W. Harrison (King). *he*, W. B. Bailey (Bulla Bull). *Lor. Zebra*.—1, E. Taylor. *rhe*, W. Walter. *he*, W. B. Bailey. *c*, J. W. Harrison. *Any other Variety*.—1 and 2, J. W. Harrison (Grass Parakeets and Cardinals). *2*, Mrs. Bailey (Witch). *rhe*, W. Walter (Madagascar and Waxbills); W. B. Bailey (Cardinal); Mrs. Bailey (Widow).

DERBY CANARY SHOW.

(From a Correspondent.)

THE thirteenth annual Exhibition of Canaries and other cage birds took place at the Athenæum, Derby, on the 5th and 6th inst. The first twenty-three classes were confined to members of the Society. There are fifty-five members, and amongst them are some of our best All-England exhibitors. I will just mention here that Mr. Bexson, the Honorary Secretary (and a more enthusiastic fancier I have never met with), has had the misfortune to lose nearly the whole of his valuable stock—a circumstance much to be regretted, and I am sure he will have the sympathy of every true fancier. For a valuable silver cup, offered by Mr. E. Bearnrose, for Crested Buff, equal points were gained by three members.

The following are the birds which are deserving of special notice:—33, Clear Buff Norwich, exhibited by Mr. J. Orme, rather above the average; 35, Marked Yellow, exhibited by Mr. Keys, is good in colour; 61, Marked Buff Norwich, shown by Mr. J. Orme, is a grand bird, and will be heard of again. 72, A. Upton, a good bird; 81, J. Marshall, a very fine bird, and it would have been first in the Open class. 101, Green Norwich (Yellow), G. Fisher, and 106, G. Fisher, Green Norwich Buff, were also fine; 114, Silver-spangled Lizard, S. Bunting, a bird that will stand well whenever exhibited. 123, S. Bunting, Mealy Goldfinch Male, was a very handsome bird, light, and evenly marked.

I will next notice those classes open to all England. I was surprised to find so few entries, as the prizes offered were exceedingly good, being £1 for the first, and 10s. for the second prize in the Norwich classes. In one class there was no competition. Clear Yellow Norwich, 111, W. Jerram, and 136, S. Bunting, were fair birds; Clear Buff, 151, J. Bennett, was a grand bird; 141, J. Prosser, was also a fair specimen; 154, Marked Yellow, was a fine bird, extra good in colour, and of good size; 162, W. Jerram, is the best I have seen this season, well marked and good in colour; it is sure to stand well when sent out, if in condition. The attendance of visitors was very good; in fact, the room was crowded. The following is the prize list:—

MEMBERS' CLASSES.

BELGIAN.—*Clear Yellow*.—1, J. Bexson, Derby. *2*, T. Keys, Derby. *Clear Buff*.—1, T. Keys. *2*, J. Bexson.

NORWICH.—*Yellow*.—1, J. Audley, Derby. *2*, S. Harris, 3, J. G. Edge, 4, J. Orme, 5, J. Judge. *he*, W. Sherwin, C. S. Bunting. *Clear Buff*.—1, J. Orme, *2*, J. Marshall, 3, S. Bunting, 4, D. Audley, 5, G. Fisher. *he*, J. Nichols, C. J. Keys. *Marked Yellow*.—1, T. Keys. *2*, S. Harris. *3*, E. Orme. *4*, G. Fisher. *5*, W. Sherwin. *he*, C. Marsden, C. Upton. *Marked Buff*.—1, J. Orme. *2*, S. Harris. *3*, J. Marshall, 4, J. Nichols, 5, J. Bennett. *he*, J. G.

EDGE. C. C. MARSON. *Variagated Yellow*.—1, A. Utton. 2, S. Bunting. 3, T. Keys. 4, J. Judge. 5, S. Harris. *hc*, J. Marshall. C. G. Fisher. *Variagated Buff*.—1, J. Marshall. 2, A. Knight. 3, J. G. Edge. 4, R. Crossall. 5, J. Bennett. *hc*, S. Stokes. C. S. Harris. *Crested Yellow*.—1, T. Keys. 2, W. Sherwin. 3, J. Stokes. *Crested Buff*.—1, S. Over. 2, N. Banks. 3, W. Sherwin. 4, J. Durance. *Green* (Yellow).—1, G. Fisher. 2, J. G. Edge. 3, J. Judge. (Buff).—1 and Special, G. Fisher. 2, J. Judge. 3, A. Knight.

LIZARD.—*Golden-spangled*.—1, S. Bunting. 2, T. Keys. *Silver-spangled*.—1 and Special, S. Bunting. 2, A. Utton. 3, T. Keys.

CINNAMON.—*Jonque*.—1, J. Bexson. *Buff*.—1, J. Judge. *Marked* (Yellow).—1, J. Judge. 2, J. Bexson. 3, A. Knight. (Buff).—1, G. Taylor. 2 and Special, J. Bexson. 3, W. Sherwin.

GOLDFINCH MULE.—*Jonque*.—1, S. Bunting. 2, J. Judge. *Mealy*.—1, S. Bunting. 2, J. Bryan. 3, J. Judge. *Dark Jonque*.—1, A. Knight. 2, J. Judge. *Dark Mealy*.—1 and Special, S. Bunting. 2, J. Judge. *Any other Variety of Mule*.—1, J. Bryan.

OPEN CLASSES.

NORWICH.—*Clear Yellow*.—1, W. Jerram, Nottingham. 2 and c, S. Bunting. *hc*, T. Keys. *Clear Buff*.—1 and *hc*, J. Bennett, Derby. 2, J. Prosser, Derby. C. S. Bunting. *Marked Yellow*.—1, J. Bennett. 2, J. Prosser. *hc*, W. Jerram.

Variagated Yellow.—1 and c, W. Jerram. 2, T. Keys. *hc*, J. Poole, Sutton-in-Ashfield. *Variagated Buff*.—1, J. Kevel. 2, W. Jerram. *hc*, J. Clarke, Derby.

BELGIAN.—*Clear Yellow*.—1, J. Close, Derby. 2, J. Turner, Derby. *hc*, T. Keys. *Clear Buff*.—1, J. Turner. 2, J. Close. *Marked or Variagated Yellow*.—1, S. Bunting. 2, J. Turner. *Marked or Variagated Buff*.—1, J. Turner. 2, S. Bunting. *hc*, J. Close.

LIZARD.—*Golden-spangled*.—1, J. Poole. 2, W. Bacon, Nottingham. *Silver-spangled*.—1, J. Poole. 2, T. Keys.

GOLDFINCH.—1, S. Bunting. 2, T. Keys.

LINNET.—1, T. Keys. 2, F. Balderstein, Derby.

BANTAMS (Irrespective of breed).—1, H. Shumack. 2, J. Bow. *hc*, D. Otwell; A. D. Forrest, Derby; J. Slater, Meynold, Langley. c, D. Otwell; J. S. Watson, Delper.

JUDGES.—*Canaries*: Mr. G. Moore, Northampton; Mr. E. Bemrose; Mr. G. H. Goodwin. *Bantams*: Mr. G. A. Crewe, Etwell.

DARLINGTON CANARY SHOW.

MESSRS. DENHAM and Stewart's anxieties were quieted on Friday last with a goodly entry of more than 250 birds. Southampton with its tempting schedule stood in the way, while the Derby Show possibly attracted some who would otherwise have sent north; but the energy of the officers of the Darlington Society overcame all difficulties, and local and other exhibitors, responding to the appeal of the Secretary, sent liberal entries for the support of a show which deserves well of the fancy.

"WILTSHIRE RECTOR" is right—the field is not large, and it does become tedious to travel over the same ground frequently. It is only now and then, when some new name appears in the catalogue, or some new star shines out in the firmament, that detailed descriptions of individual specimens will interest. One meets with the same birds show after show, and some evergreen specimens even year after year, which chirp out a cheery "how d'ye do" with all the vigour of youth, having apparently taken a fresh lease of life with their new suit of clothes. The chief points of interest in a show are the new birds, and most of these I think I reviewed in my notes on Scarborough. Appended will be found a list of the prizetakers, and if I select anything as being worthy of special note it must be the Brown Linnet Mules shown by Mr. Spence and Mr. Robinson, and Mr. Rutter's Belgians. The Mules are remarkable birds, Mr. Spence's being a cock of good size and colour, pencilled on the eyes—the marks being somewhat enlarged in the direction of the neck—small cap, wings evenly, lightly, and decidedly marked, slight discoloration of the silky fluff at the rump, with the rest of the body and tail quite clean. Mr. Robinson's is a hen, and is, of course, smaller, and carries but little if any colour, is nicely pencilled on the eye, though one mark extends into something which assumes the character of a blotch on the neck, top of the head clean, wings nicely marked but much piled at the base of the saddle, and a black feather on one side of the tail. Mr. Rutter's Belgians are well known; suffice it to say that the oldest fanciers admitted they had never seen such birds before, and not a few said they did not know such things existed except in pictures. Mr. Rutter held a grand levee on Saturday afternoon, "lifting" his beauties and putting them "up" regardless of the wear and tear of his finger nails, illustrating their "points" with a terseness of style and aptness of simile which only those who have heard him can appreciate. A group of fanciers round a Belgian is a study for an artist.—W. A. BLAKSTON.

BELGIAN.—*Clear Yellow*.—1 and 2, J. Rutter, Bishopwearmouth. 3, F. Rawnsley, Bradford. *Clear Buff*.—1 and 2, J. Rutter. 3, G. Tomlinson, Stockton. *Variagated, Ticked, or Uneven-marked*.—1 and 2, J. Rutter. 3, T. Craggs, Stockton.

NORWICH.—*Clear Jonque*.—1 and 3, T. Irons, Northampton. 2, W. Gamble, Northampton. *Clear Buff*.—1 and 2, W. Gamble. 3, R. Lavfield, Darlington. *Evenly-marked Jonque*.—1, E. Mills, Sunderland. 2, R. Hawman, Middlesbrough. 3, J. Robson, Morthth. *Evenly-marked Buff*.—1, W. & C. Burniston, Middlesbrough. 2, W. L. Heloe, Berwick-on-Tweed. 3, G. Gayton, Northampton. *Dark or Grey-crested*.—1, R. Hawman. 2, T. Irons. 3, J. Calvert, York.

CANARY (Any Crested variety).—1, Fairclough & Howe, Middlesbrough. 2, W. Cotton, Middlesbrough. 3, G. Gayton.

LIZARD.—*Golden-spangled*.—1, R. Ritchie, Darlington. 2, E. Mills. 3, P. Rawnsley. *Silver-spangled*.—1 and 3, R. Ritchie. 2, J. Baines, York.

CINNAMON.—*Jonque*.—1 and 3, T. Irons. 2, S. Tomes. *Buff*.—1, T. Irons. 2 and 3, W. Gamble.

YORKSHIRE.—*Clear Yellow*.—1, H. Winter, Guisborough. 2, E. Mills. 3, L. Belk. *Clear Buff*.—1, W. Hutton, Leeds. 2, E. Mills. 3, J. Cooper, Middlesbrough. *Evenly-marked Yellow*.—1, P. Rawnsley. 2, Stevens & Burton, Middlesbrough. 3, A. Webster, jun., Leeds. *Evenly-marked Buff*.—1, R. Hawman. 2, P. Rawnsley. 2, Tenniswood & Brown, North Acliam.

ANY OTHER VARIETY.—1, R. Hawman. 2, T. Wales, Stockton. 3, W. Bulmer. 3, W. Russell, Darlington.

MULE.—*Evenly-marked Buff Goldfinch*.—1, W. & C. Burniston. 2, J. Robson. 3, R. Hawman. *Dark Goldfinch*.—1, Stevens & Burton. 2, E. Stansfield, 3, H. Winter. *Any other Variety*.—1, J. Spence. 2 and 3, C. Robinson.

CANARY (Clear Green).—1, G. Atkinson, Gateshead. 2, Stevens & Burton. 3, Goldfinch. —1, Stevens & Burton. 2, Tenniswood & Brown.

LIZARD (Brown).—1, Tenniswood & Brown. 2, A. Webster, jun.

BRITISH BIRDS (Any other Variety).—1, A. Fletcher (Starling). 2, W. Hodgson, Darlington (Thrush).

PARROT (Any variety).—1, — Moses, Darlington. 2, J. Scott, York. 3, T. Bowman, Darlington.

FOREIGN BIRDS (Any variety).—1, J. Calvert. 2, W. J. Stewart (Cockateils). 3, W. Hodgson (Love Birds).

JUDGE.—Mr. W. A. Blakston, Sunderland.

CROYDON COLUMBARIAN SOCIETY.

THE amateur Pigeon fanciers of Croydon and its neighbourhood being very numerous, have formed themselves into a Society under the above title, and have arranged to hold their meetings monthly, at the Greyhound Hotel, Croydon. Amongst the members are some of the principal breeders and fanciers in the country, and in a short time the Society will doubtless become one of the most prominent. One of the rules is the total exclusion, either as members or visitors, of all persons who come under the denomination of dealers, and it is the intention of the new Society to limit its members to amateur fanciers only. The officers are to be elected annually, those for the present year being F. S. Wiltshire, Esq., President; T. T. Keen, Esq., Vice-President; and Mr. J. B. Jayne, Honorary Secretary and Treasurer.

THE YORK RABBIT SHOW

THE schedule of prizes for Rabbits, issued by the Poultry Committee of the Yorkshire Society for the exhibition of fat stock, is the very best ever issued by any committee in England. Take the schedule of the last show of the Hull Society, now extinct, of which your correspondent, Mr. S. G. Hudson, was one of the committee, and we find three classes for Lop-ears, and a silver cup; only two classes for fancy varieties, and no cup nor anything. Also, take the Rochdale, Keighley, Long Sutton, Middleton, and Airedale Shows, and we see that there is not nearly so much money offered, nor so many classes, as at the York Show.

As to those two £5 5s. cups for Lop-ears, they have been collected by those who are fanciers of Lop-ears only. If your correspondents had wished to have had a cup for the fancy varieties, they should have expressed their desire, the same as the Lop-ear fanciers did, written to the Committee guaranteeing the cup, and have collected the money for it. The Committee would have been only too glad for them to have done so. The medal for the fancy varieties has been given in this way; a gentleman thought we ought to have something, and gave practical expression by collecting for a medal.

As to the fancy varieties being shown in pairs, I differ from your correspondent; I think they ought to be shown in pairs, and from what he states it seems he has never attended the York Show, or he would have seen, instead of disgusting scenes, and Rabbits going home in a breeding state, that the pens are divided, the Rabbits having no chance of being together.

Since giving up the fancy it has been my desire, as far as possible, each year to improve the schedule, and in this I have succeeded; a year or two since there were only some £4 or £5 given in prizes, now there are £12 10s., besides the cups and medal, and since last year we have added some £1 to the schedule, the major part of which goes to the fancy varieties, and if we are encouraged this year with large entries in those classes, we intend to ask the General Committee for more money, and make all classes equal; but we cannot do this unless we have the support of the exhibitors; and let those gentlemen remember that there is only a difference of 5s. in the first prize, the second being equal with the Lop-ears. It is impossible for a society to give valuable prizes unless they have large entries, and we do think we ought to be largely patronised for the prize list issued. I hope all Rabbit exhibitors in England will enter largely. Our Show is perfect in its arrangements; we have a man to each department night and day, the Rabbits are fed with suitable food three times a-day, and are returned with the utmost despatch; and I can promise all exhibitors that they may send their stock with safety, for their specimens will be as comfortable as at home.—M. MILLINGTON, York.

GREAT LONDON POULTRY SHOW.—We would draw the attention of intending exhibitors to the schedule of the above Show, the prizes being very valuable and the classes excellently ar-

ranged. Exhibitors of nearly every variety of poultry and Pigeons will here find a class. It will be noticed that the entries close on Saturday next, November 12th.

CHAUCER'S CHANTICLEER.

In the "Canterbury Tales" Chaucer describes a "Cok highte Chanticleere" as follows:—

"His combe was redder than the fin corral,
Embattled, as it were a castel wall,
His bill was black, and as the jet it shone;
Like asure were his legges and his tone;
His nyles whiter than the fly flour,
And like the burned gold was his colour."

The only word in the foregoing passage requiring the aid of a glossary is "tone," which means toes.

We have described, then, as *the* cock of the fourteenth century a single-combed bird (for I judge the phrase "embattled, as it were a castel wall" refers to the serrations of the comb which justify the comparison), probably of a reddish colour, with a black bill, with blue legs and toes, and with white nails. Chanticleere probably had neither crest, muff, nor beard; his deaf-ears were not conspicuous, and his wattles were not large, otherwise we may be sure the poet would have mentioned them. What was his breed? Must we yield to the dung-bill the honour of a place in "Canterbury Tales" or can we claim it for some of our favourites of to-day?

The description suggests the Golden Hamburg, but the description of the comb will hardly do; so observant a man, who is so minute and careful, would not have omitted the conspicuous white deaf-ear. Nor can we claim it for our Golden Polands for similar reasons.

The only other point of interest connected with chanticleere worth mentioning is, that "this cok had in his governance seven hennes."—(*Poultry Bulletin*)

HOW LONG ARE YOUNG QUEENS IN EMBRYO?

I wish it to be understood that in all my experiments I have left nothing to chance. My hives are not dark straw hives, where the natural history of the bee is at the best but a surmise, but are frame hives (condemned in "The Handy Book"), capable of being transformed into observatory hives in a few minutes, and from these my observations have all been taken.

Now, the first question I have before me is, Do bees carry eggs from one hive, or from one part of a hive to another, and place them in royal cells? I say unhesitatingly, No; for I have witnessed hundreds of queens raised and hatched, and have placed these eggs in the most unfavourable positions, so that if bees ever did shift them, they would certainly have done so; and, as a proof of this, I have at present a piece of comb with seven queen cells, which was commenced inside a hive, but which was removed outside, and although eggs were present, the bees failed to carry in a single one, but have continued to stick to the comb with royal cells outside the hive, the eggs in which are at this moment within a few hours of hatching.

The next question is the one now in course of discussion regarding the time queens are in being hatched. To this I would reply that it depends on circumstances, and the circumstances are these. Suppose we take a piece of comb with eggs and brood in all stages, and give it to a hive without a queen, in all probability the bees will commence to raise queens from both eggs and grubs, and in thirty hours we may find one or more queens sealed over, and which will be hatched on the ninth day, or exactly eight days from the time of being sealed. Others in a less forward state will be later, and some may extend to the seventeenth day, exactly sixteen days from the depositing of the egg, which is what we want to know—viz., the exact time from the old queen leaving the cell, where she has deposited the egg, until the time the young queen makes her exit from the same cell. In all cases where I have either seen the eggs deposited or knew when they were laid, I have never known a queen hatched in less time than sixteen days, or on the seventeenth day after the egg being laid; and instead of their being less than sixteen days, I have known them kept prisoners for twenty, and even twenty-one days after being laid. This imprisonment occurs only in hives intending to swarm therefore ocular demonstration proves that it requires sixteen days to bring a queen to maturity. I can with safety say that I have been present at the birth of the majority of my queens hatched during the past six years, and I may add, so near was

I in my reckoning, allowing sixteen days, that I have often caught them in the act of leaving their cells, and have seldom had to wait many hours until they did so.

There is another question—viz., Can queens be raised from drone eggs, or rather eggs that would produce drones? My answer to this is, No; and any person who says that they can has but a very imperfect idea of the natural history and anatomy of the honey bee. Without entering into details on this subject, I will merely quote one instance as a proof against this theory, and ask why bees fail to produce queens from the eggs of a virgin or drone-breeding queen?—A LANARKSHIRE BEE-KEEPER.

A DIFFERENCE of opinion appears to prevail in regard to the length of time required for the evolution of a queen from an egg. Mr. Woodbury has fixed the period at sixteen days, or thereabouts, and to my mind no evidence has yet been adduced to show that he is mistaken. The fact can only be determined by correct observation and experiment.

With a view to solve the problem, or rather to obtain additional proof on the point, I introduced on the 25th of August last a fertile queen to a populous hive containing plenty of honey, but neither eggs nor brood. On the 29th and 30th eggs were deposited in one of the combs over a space of 4 square inches, and then I removed the queen that others might be raised from the eggs. Royal cells were only formed, but on the afternoon of September 13th none of them were found opened, although fully fourteen days had elapsed from the hour of the old queen's removal. It was not till the morning of September 14th that the eldest young queen obtained her liberty. Moreover, this queen emanated from one of the earlier-laid eggs; all the more recently-deposited ones having been removed, and perhaps eaten, by what are called nurse bees. On several occasions when making artificial swarms I have observed that all newly-laid eggs were destroyed. I am not prepared to say that this curious circumstance may be witnessed in every instance where bees are made to evolve young queens from a comb containing eggs, but it certainly does very frequently happen. Sometimes when a comb has contained eggs only, all but those destined for queens have been destroyed, not a single bee having been allowed to be hatched from one of the eggs. In cases where there are larvæ as well as eggs, it will be found that the recently-deposited eggs are also made away with, although all the larvæ are carefully nursed.

The facts now stated have not, so far as I am aware, been mentioned by any writer, and I would not at the present moment have alluded to them but for their bearing on points now debated; for if a comb contained eggs only, and the age of the eggs in each portion of the comb has not been well ascertained and marked, it is quite impossible to fix what length of time has been occupied in the evolution of a queen from any of them.

The experiment I have detailed shows that it required, under very favourable circumstances, and during remarkably fine weather, more than fourteen days for the production of royalty from an egg, and I suppose most apiarists entertain the belief that an artificially-reared queen is not detained in her cell a single moment beyond her wishes. If it is the case that young queens occasionally make their appearance before the sixteenth day, dating from the moment when the egg was placed in the cell, they will, I imagine, present an immature appearance. I must, therefore, in the meantime hold to the conviction that either observations not made with sufficient accuracy, or that exceptional cases of premature birth, have led to the erroneous belief that fourteen, and not sixteen, days are required in the production of queens.—R. S.

OUR LETTER BOX.

PARTRIDGE COCHIN-CHINA AND BLACK RED GAME COCKS (*Torquay*).—Neither red dull in the first, nor blue legs in the second are disqualifications, nor are they even faults of any importance. We repeat that which we had said many times—there is no colour for the legs of a Game fowl which is a test of purity or otherwise. The only rule with regard to them is, that there must be positive uniformity of colour in the legs of all the birds that go to form a pen.

BRAHMA'S EYE SWOLLEN (*W. S.*).—In any other breed than the Brahma or Cochin the inflation of the skin of the face or lower beak would be a very serious symptom. If neglected it would end in rot. It is, however, of little import with Brahmas. The bird has probably caught cold, and will soon be well. Wash the face morning and evening with cold water and vinegar; give a little stimulant twice per day, such as bread and strong beer, and until convalescence give two pills daily of camphor, each the size of a garden pea.

LAYING SOFT EGGS (*Idem*).—This arises from one of two things—either

the necessary material is not to be found in the haunts of the hen, and in that case it must be supplied in the shape of bricklayers' rubbish, old ceilings, chalk, lime, &c., or the secretions are at fault. Try the first. If it does not succeed, attribute the result to the second cause, and use Bailey's pills, which will, we doubt not, effect a cure.

COCHIN PELLETS DYING (F.).—There is nothing in your keeping that should cause your fowls to die. Your dietary is not of a high class, and if the birds came from much better keeping they would lose condition. A large gravelled atleyard otherwise unoccupied is not suggestive of healthy feedings; and Indian corn twice per day, varied sometimes with barley meal and tainag wheat, is not good feeding. With a little alteration it may be good enough. A sickly person may be ordered to take turtle, but if entirely confined to it would starve. Just so the Indian corn thrown down in the clean gravelled yard is suggestive of the children's cry, "Sick of the sight of it," when their parents expatiate on the merits of some dish on which they pin their faith. We fancy your fowls are like Dr. Blimber's boys as they appeared when enjoying themselves, whereas they should be like those unhappy children who had no one to take care of them, and who were in consequence "doing dags," "turning wheels," and "standing on their heads." Have two or three or more cartloads of road grit full of grass and small pebbles. Form them in a heap in the yard. Make another with as much mould as you can spare, cover the top of it with large sods of growing grass. Feed on barley meal or ground oats as the principal food, and let Indian corn be the occasional change. As some of the youngest chickens may want it, give them bread and milk and a little chopped egg till they have recovered strength. Cleanliness cannot be too much insisted upon in the roosting place or house; but where the runs are so intolerably clean and tidy, we are compelled to believe either that the fowls have not the various appliances necessary to health, or they are not in health to make use of them.

DISEASED CROSS-BRED HEN (E. S.).—The complaint you mention belongs more to the Spanish than the Cochlin broed. It is seldom cured, but the fowls live on, and are as useful as if they had not the excrescence. In the early stages, when the swelling is soft, it can sometimes be got rid of by making an opening and squeezing out the contents, which will generally be found to be a cheesy substance. Bailey's pills, we believe, are to be had of all the principal chemists, or at 113, Mount Street, W., London. They are very useful in keeping fowls in health at this time of year.

COCK'S TOE PARTLY LOST—HAMBERG COCK'S COMB (Constant Reader).—The accident to the Cochlin cock is of no importance. The double pike to the Hamburg's comb will be fatal if it is discovered.

BRAHMA PULLETS AND COCK (Orl.).—They should be set apart at once. They will probably lay the end of next month. Give them the largest space you can. If it possesses green food in the way of grass, &c., you need not provide it. If it does not, you must supply the same with road grit, garden mould, growing grass, and other green food. If they have a good run and the consequent advantages, give two meals per day of whole corn, the middly one of barley meal or ground oats. As they are growing birds you may also give them kitchen scraps and bread and milk. In very bad weather you may give them bread and ale morning and evening, we mean during snow or long-continued wet. Be sure their roosting place has none other than an earthen floor, and that the perches are very wide and not more than 18 inches from the floor.

SILVER-PENCILED HAMBURGERS (M. I. M.).—Assuming that all your cockerels are of the same age, we should certainly give the preference to the perfect earlobe. If they are all of the same strain, and he of the white ear be older than the others, we should not hurry to make our selection, because age will often transform the faulty into a perfect earlobe, just as it does the face of a Spanish pullet.

POULTRY FOR SALE (Notice).—Fit for exhibition is a wide term, and binds the seller to nothing. You need not wait long. Go to Birmingham Monday fortnight, and you can buy birds that have actually appeared in the first prize sheet in the world. We do not think you would be likely to buy prize birds from anyone who never takes prizes, as, even in his own case, his estimate of the merits of his birds is a mistaken one. If there were only open classes for "birds of all ages," the age of the birds forming competing pens would be taken into consideration, but one six months old would hardly ever compete successfully with one twice the age. Still at almost every show there are distinct classes for chickens and adults. The probable success of six-months chickens would depend on the time of year at which the show was held. Thus, at a show held in July it would be very difficult to get chickens more than six months old, and they would, if good, be successful. The same chickens, or their fellows, might be shown in November or December, being then nearly a year old and as such adults as they ever would be, chickens six months old would have no hope in competing with them, although they might have done so in July. Early maturity is one of the objects aimed at by those who encourage the breed of poultry. To produce chickens late in the year is of little use, as they are then of small value.

MALAYS (Minorca).—They are not Game fowls, and, if there is not a separate class for them, they must be exhibited in the "Any other variety" class.

CHICKENS CROP-BOUND (C. T.).—Your feeding must be wrong, and your fowls consequently become crop-bound and die. Those which have their crops full must have them emptied. Feed on green meat and ground food. See our instructions to "F. T." last week; we entered fully into the subject.

BRAHMA WITH TWISTED FLIGHT (T. F. A.).—Your hird has a twisted flight, and nothing will cure it. It is always a mistake to save such chickens, as they are worthless for stock, and to our ideas blots in a yard. We always devote them to the kitchen. "Wise men flustering" may tell you of cures. We have never found one.

COLOUR OF DARK BRAHMA HEN (Item).—The brown or salmon colour is a defect in a Brahma hen. If we had others as good, lacking the colour, we should not breed from her. If she has qualities that make it desirable, we should mate her with a Dark cock—that is, black and white, and above all, one without the chestnut patch on his wing or a brown feather in any part of his plumage.

EXHIBITION DARK BRAHMAS (Brahma).—We advise you to show No. 2 for two reasons. You say she is nearly as large, is better pencilled, and has no brown in her plumage. No. 1 is evidently out of health. There is no greater proof than inordinate thirst. Remove the water at once;

let her have a little morning, midday, and evening, but none to stand by her. Feed her moderately on soft food. Give her lettuce. If the thirst continue, give castor oil.

RARDS' EYKS (Belton).—As the pearl eye in these Pigeons is the proper colour—vide the article on the Pigeon in our number for October 27th—on no account cross with a bird having a crocus eye, as you will damage your stock, and get the yellow eye into it.

MEASURING THE FACES OF CARRIERS AND BARDS (Jas. Urgan).—We think the safest and best way to measure the faces of watted Pigeons is from their point to the centre of the eye itself, certainly not to the outside of the eyeball.

CURING RABBIT SKINS (Orl.).—We know nothing about the process.

COOKING SCORZONERA (N. H. P.).—You guessed erroneously; our cook's name is not "Betty," but Alicia, indicative of being quite up to palatable preparations; yet, when we imparted to her your question, she inquired, "Is it a 5-h?" so we retired from taking further counsel, and impart the following from the store of our own encyclopaedic knowledge:—Scrape off the dark outside skin of the roots; then soak them in water for an hour or more to extract a portion of the bitterness; then boil them till soft, like the parsnip, and send to table to be eaten with either white sauce or melted butter.

METEOROLOGICAL OBSERVATIONS In the Suburbs of London for the week ending November 8th.

Table with columns: DATE, BAROMETER (Max, Min), THERMOMETER (Air, Earth: 1 ft, 2 ft), Wind, Rain. Rows include Wed, Thurs, Fri, Sat, Sun, Mon, Tues, and Mean.

- 2.—Foggy; fine, foggy; frosty fog at night.
3.—Frosty fog; foggy, dense fog; frost, dense fog.
4.—Dense fog; densely overcast; overcast.
5.—Densely overcast; very fine; densely overcast.
6.—Densely overcast; fine; densely overcast.
7.—Frosty; rain; fine; heavy clouds.
8.—Frosty air; dense fog; foggy and frosty.

COVENT GARDEN MARKET.—NOVEMBER 9.

THE attendance of buyers has been hot limited during the past week and as the stocks have much accumulated forced sales have been resorted to, but without much influencing the current rates. Some heavy consignments of Pears from France, shipped at Dieppe and St. Malo, have passed under the hammer this week. We have also received a good parcel of Newtown Pippins from New York. The Potato trade is rather active.

FRUIT.

Table of fruit prices including Apples, Apricots, Cherries, Chestnuts, Currants, Figs, Filberts, Gooseberries, Grapes, Lemons, Melons, Mulberries, Nectarines, Oranges, Peaches, Pears, Pine Apples, Plums, Quinces, Raspberries, Strawberries, and Walnuts.

VEGETABLES.

Table of vegetable prices including Artichokes, Asparagus, Beans, Broad, Beet, Broccoli, Brussels Sprouts, Cabbage, Capsicums, Carrots, Cauliflower, Celery, Coleworts, Cucumbers, Fennel, Garlic, Herbs, Horseradish, Leeks, Lettuce, Mushrooms, Mustard & Cress, Onions, Parsnips, Peas, Potatoes, Quinces, Radishes, Rhubarb, Savoy, Sea-Kale, Shallots, Spinach, Tomatoes, Turnips, and Vegetable Marrows.

POULTRY MARKET.—NOVEMBER 9.

THE supply is moderate, and the demand very small. The lamentable war on the Continent has closed our best markets for the sale of Game, and will influence the price of it greatly. We expect it will be difficult to sell many pheasants, except at very low rates.

Table of poultry prices including Large Fowls, Smaller ditto, Chickens, Ducks, Geese, Pheasants, Pigeons, Rabbits, Wild ditto, Hares, Partridges, and Grouse.

WEEKLY CALENDAR.

Day of Month.	Day of Week.	NOVEMBER 17—23, 1870.	Average Temperature near London.			Rain in last 43 years.		Sun Rises.		Sun Sets.		Moon Rises.		Moon Sets.		Moon's Age.		Clock after Sun.	Day of Year.	
			Day.	Night.	Mean.	Days.	m.	h.	m.	h.	m.	h.	m.	h.	Days.	m.	s.			
17	TH	Meeting of Linnean Society, 8 P.M.	48.1	33.9	41.0	19	23	af	7	8	af	4	morning.	6	af	2	24	14	53	321
18	F		47.9	32.9	40.4	20	25	7	8	4	41	0	29	2	25	14	40	322		
19	S	Length of night 15h. 20m.	48.9	33.5	41.2	17	27	7	7	4	2	2	51	2	26	14	27	323		
20	SUN	23 SUNDAY AFTER TRINITY.	48.7	34.6	41.7	14	28	7	6	4	25	3	12	3	27	14	13	324		
21	M	PRINCESS ROYAL BORN, 1840.	49.6	36.2	42.9	26	30	7	4	4	49	4	37	3	28	13	58	325		
22	TU		49.2	34.7	41.9	22	31	7	3	4	17	6	4	4	29	13	42	326		
23	W	ST. CLEMENT.	47.6	34.2	40.9	18	33	7	2	4	45	7	39	4	30	13	25	327		

From observations taken near London during the last forty-three years, the average day temperature of the week is 48.6°, and its night temperature 34.3°. The greatest heat was 61°, on the 20th, 1866; and the lowest cold 18°, on the 19th, 1868. The greatest fall of rain was 0.35 inch.

FRUIT TREES FOR SMALL GARDENS.—No. 1.



ROBABLY no gardens are so much neglected and on the whole so badly arranged as farm and cottage gardens. Horticultural societies established in almost every town encourage improvements of various kinds; and there is the horticultural press placing within the reach of all information on gardening that will not fail, if acted on, to improve both flowers and fruit. Nothing, however, seems as yet to have made any salutary impression

on the minds of the great mass of British farmers and cottagers, many of the latter being employed by the farmers, who ought to give them encouragement, and set an example of good management in their own gardens. Horticultural societies and the gardening journals to a laudable extent encourage cottagers to attend to the culture of their gardens, but how can they hope to succeed when employers offer such examples of slovenly garden management? It is remarkable that gentlemen, especially landed proprietors, who for the most part have tasteful, productive, well-kept gardens, do not take notice of the neglected and slovenly condition of the gardens attached to their farmhouses, and do not use their influence with their tenants to induce them to pay more attention to garden-culture and keeping.

Although agriculture and horticulture are kindred pursuits, strange to say there is no class of the community so ignorant and destitute of taste in respect to gardening as the great majority of our farmers. To such a pitch is this disregard for the garden carried that many of them own their ignorance with a clownish boast, as if the culture of their gardens were a concern utterly contemptible, or far below their notice. Some members of their family may have a taste for the culture of flowers, fruit, or vegetables; but the ill-assorted, discouraged, and often abortive attempts at anything like taste or ornament are more calculated to excite commiseration than any other feeling. There are, no doubt, some well-arranged, well-managed farmhouse and cottage gardens, but such are not the general rule.

Can nothing be done to remedy this contempt of farmers and cottagers for their gardens? Horticultural societies have offered premiums time after time; the press has chronicled the event, and instructions have been given so often that one might if so disposed have had them off by heart; but after all the gardens remain as they were before. It is not want of taste for flowers and fruit that withholds farmers and cottagers from attending to the culture of their gardens, for they are ardent admirers of both. They take pleasure when spring returns in wandering in gardens, and seeing the Lilies shooting from the ground, and the buds of the fruit trees full even to bursting. They wonder how a Crab grew into an Apple, the Sloe into a Plum, and the single became a double Daisy. It is a marvel to them how the Vine bears its Grapes, and the Pine Apple has its summer flavour whilst the snow is as yet unmelting on the hills. None admire more than they do the beauties of choice flowers and fruits, but after

they have highly extolled all they see in our best gardens they find something that affords them a sort of consolation—they have seen many fine fruits, but none equal to what they have, perhaps by the bushel, from a standard tree.

Another obstacle to farmers and cottagers moving from the old track is they see no place for fruit trees but an orchard, and no description of trees but standards. As to kinds, they do not look for better than those which they or some neighbour may have—sorts that are very often but slight removes from our Crabs. If prevailed on to procure new kinds, they think these must be grown as standards, and the expectation of getting as fine fruit from them as they see elsewhere on bushes, pyramids, or espaliers turns out a miserable disappointment, for the kinds are wholly unsuitable for standards, like almost all our best varieties of Apples, Plums, and Pears.

Another cause of the adherence of farmers in garden matters to old notions consists in the persons applied to for information when anything new is contemplated. In almost every village there is the presiding genius in the man who has a neat garden of his own, and grows plants for sale, besides going out to "do-up" gardens. Brought up in orchards, and believing in no garden unless it is shaded by standard trees that will neither allow of flowers succeeding nor of vegetables attaining perfection, his ideas do not soar higher than his knowledge. He advises, and his advice is generally adopted, for it is in accordance with their own opinions—adverse to what are called new-fangled notions. This person advises and plants for the British farmer, and his cottager procures through him fruit trees of inferior kinds, and of a description more likely to fruit with the next tenant than with the present one. What a wondrous creature of hope—hope that a tree with a stem like a walking stick and a head like a mop will grow and become strong and spreading like an Oak, as it must before it will produce the bushels of fruit expected of it! Until garden knowledge be more generally diffused—until there be in every village competent persons able to act and advise on gardening in its best and most approved principles, there will be that paradise of prejudice in which men dream away their time.

It has been said, and I think wisely, that those prepared to point out a grievance should be prepared with a remedy. The first suggestion that I have to offer is that the clergy of every parish should undertake the instruction of cottage gardeners. Being in general well posted up in the best and most improved kinds of fruits, the most profitable form of trees or systems of growing them, and, from their avocation looked up to, their advice and instruction would go a long way in producing a change. Indeed, with a well-kept garden, at times free to the inspection of the villagers, especially if it could be backed up by a show, there would be awakened such a spirit of innocent rivalry and a desire to excel in garden produce that any extra trouble would not be felt, whilst the improvement would be manifest everywhere, giving to many a family a health more precious than rubies. Some, I am aware, are already engaged in this noble work—aiding in fulfilling the intentions of

Providence, striving to give to every home health, comfort, and happiness. Could not they be prevailed on to give in the "Cottage Gardener" columns the benefit of their experience for the good of others, who are only kept from the work from want of a plan?

With the farmers it would perhaps be more difficult to deal. Persuasion and example would avail but little, but could they not be reached through the landlord? What if the landlord were to provide a properly qualified gardener, competent to renovate the gardens attached to farms or houses? This person might be found by the landlord, the farmer paying him for his labour at a rate fixed by the landlord, or the expense might be wholly paid by the landlord in the first instance, the tenant being charged with the interest of the outlay in respect of stock and improvements, the "keeping in order" being paid by the tenant. I am sure that farmers, as a rule, would not object to this sort of thing, but would do all in their power to further it. The only difficulty would be in making sure of the person appointed having the requisite knowledge. I am not unmindful of "A YOUNG GARDENER'S GROWL," but I do not think so few gardeners as he states are able to advise as to a list of fruits, and that without tasting, as he will learn by-and-by when he has to supply fruit for the kitchen and dessert. But any objection of that kind might be got over by the landlord's gardener having the supervision of the gardens and the control of the persons who attend to them. In that case nothing could be done to the detriment of either the landlord or tenant, as might otherwise be the case were an inexperienced hand to cut down what could not be replaced without entailing a serious loss on the tenant, and he could be kept from planting what would not be of any value to him, or not for a very long time. The landlord might stipulate for a certain amount of flower, vegetable, and fruit garden, and an orchard if thought necessary, to each holding, and the occupiers could exercise their discretion in what they would have it cropped with, always keeping from them the power of interfering with the permanent subjects without first consulting with the landlord or his agent.

The gardener should be able to lay-out gardens, and practically understand every department of out-door gardening. On some estates it would be necessary to have a superintendent, with properly-qualified assistants. It has always appeared to me remarkable that the gardening market should be overstocked, and yet there is no wonder when half the gardening of the country is performed by persons styling themselves gardeners, but knowing practically but little of it outside their own minds.—G. ARBEY.

CLIMBING FERNS.—No. 3.

In my two previous articles I have confined myself to Ferns whose fronds have the power of extending themselves, if not indefinitely, at least to a very unusual length, by the continuous growth of their points. We now, however, come to a distinct set of plants, which, although they must undoubtedly be accepted as climbing Ferns, yet owe their claim to this title only from the extension of the rhizome which roots into or around whatever it can affix itself to. Very fine objects can be made with some of these by planting the dead stems of tree Ferns in various parts of the fernery, and fastening upon them the kinds with scandent rhizomes; or if no tree Fern stems are to be had, small cylinders of galvanised wire may be placed so as to represent pillars or archways, and these, having been previously filled with peat and sphagnum moss, will be fitting receptacles for the kinds with creeping rhizomes presently to be named. Fern-growers who have not a fernery in which their pots can be planted in the open border need not despair, and, certainly, must not neglect such plants as those treated of in this article, because they will be even more appreciated in a collection that is confined to pot culture; to such I say, Pot your dead Fern stem or your cylinder of wire, then fix the creeping rhizomes to it, when, if duly supplied with moisture, they will soon establish themselves, and the effect will be as good as if they had been planted in the fernery borders.

OLEANDRA.

This is a very elegant and thoroughly distinct genus of stove Ferns, characterised by their hairy rhizomes and simple fronds, which are of firm texture with jointed stipes. The veins are simple, sometimes forked, having a short venule terminating near the midrib, on which the sori are situated, and which are furnished with a reniform indusium. These plants adhere very closely to any congenial surface, and, as a natural

consequence, the more nutriment they obtain, the larger fronds they develop. Several more species than those here enumerated are known to exist, and when introduced in a living state to this country will be valuable additions to our collections.

O. ARTICULATA.—This is a beautiful Fern with entire linear-lanceolate fronds from 10 to 15 inches long, tapering at either end, and light shining green in colour. When treated in the manner previously described, it produces a fine effect. It is a native of the East Indies and the Mauritius.

O. NODOSA.—Like the preceding, this species produces simple fronds, which are about the same shape and size as in that

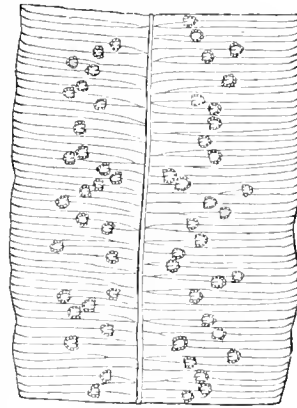

plant; it is distinguished from it, however, by its black shining stipes, and the darker green of its fronds, part of one of which is represented in the accompanying engraving. *O. nodosa* should be grown in the same manner as before mentioned, and if planted upon the stem of a tree Fern the effect is charming. It is a native of the West Indies.

O. WALLICHI.—This is a somewhat rare kind, but fully as beautiful as those previously named. The fronds are simple, varying from 12 to 18 inches in length, and from 1 inch to 1½ inch in width, with

slightly undulating margins. The sori are large, light brown, and situated very close to the costa or midrib. The colour is bright light green. Native of the East Indies.

O. NEMIFORMIS can only be called a sub-scandent species, but it is such a beautiful plant that I cannot refrain from including it with the others. It has simple fronds about 12 inches in length, arranged in a verticillate manner, which give them the appearance of large fans, and the effect it produces is so strikingly distinct that it should be one of the first plants procured for a collection of Ferns. Native of both India and South America.

POLYBOTRYA.

This genus belongs to the tribe Acrostichæ, although differing considerably in appearance from the plants we are apt to associate in our minds with Acrostichum. They may be known by their stout squamose rhizomes, bi-tripinnate fronds, free pinnate veins, and contracted fertile fronds, which are entirely covered on the under side with sporangia. Polybotryas are large-growing plants, and climb trees to considerable heights. In a large fernery where space for their development can be afforded, they form truly noble ornaments, and should be treated in the same manner as recommended for *Oleandra*.

P. OSMUNDACEA.—In this plant we have boldness of character well developed. It produces a stout creeping rhizome clothed with long brown chaffy scales, and which climbs to considerable heights. Its fertile and sterile fronds are very dissimilar, the latter are bi-tripinnate, from 2 to 3 feet long, with oblong pinnae tapering towards the apex, obtusely lobed, and of a rich green. The fertile fronds are equal in size to those which are sterile, but have all the pinnules contracted into linear segments, which are wholly covered with dark brown sori. It requires stove heat, and forms a fine specimen. It seems to be abundant in Brazil, various parts of South America, and in the West Indies.

P. CAUDATA.—Another superb strong-growing Fern with a stout climbing acaly rhizome. The fronds are tripinnate, lengthened out into a long tail-like point, as are also the pinnae; the pinnules are broad-oblong, rounded at the base, tapering to a point, dentate at the edges, and bright shining green in colour, like *P. osmundacea*; the fertile fronds are contracted, the pinnules being linear, about 2 inches in length, slightly eared at the base on the superior margin, and wholly spangiferous. It is a noble ornament in a large fernery. Native of South America and the West Indies.

ARTHROPTERIS.

This genus would appear to have no striking character or characters to distinguish it, and it seems to me to be very near to *Nephrolepis*, but is wanting in respect to the thin wiry

rhizome so peculiar to that family. Arthropteris has a thin scendant rhizome, and the stipes are jointed, and the pinnae are likewise jointed to the rachis; the latter have free forked veins, the round sori being situated on the apex of the lower venule. Indusium small, and soon obliterated.

A. OBLITERATA is a peculiar plant, and one which has led to much discussion; it has been shifted from one genus to another until one scarcely knows what to call it. This plant may, perhaps, be more familiar to my readers by the name of *Lindsea Lowii*, for by this name it has been distributed, but it certainly bears no relationship to that family. It is also to be found in some collections as *Polybotrya Lowii*, but I am equally doubtful of its proving an acrostichoid Fern at all; it certainly bears more resemblance to Arthropteris than anything else I have seen. In a cultivated state the fronds of this plant have assumed three distinct forms, but as far as I am aware it has not yet fruited, which is much to be regretted. In the first form the pinnae are developed only on one side of the rachis, they are obtusely lobed and decurrent; they are ultimately produced on both sides of the rachis, still lobed, and decurrent; after producing a quantity of fronds of this form suddenly the fronds appear with distant, broad, and entire pinnae, somewhat rounded at the base, and acuminate at the apex. In this state the plant looks very like a *Nephrolepis*, and I do not anticipate any further alteration in its form, saving the production of sori. Its fronds are bright dark green, and it should make a fine object upon the stem of a tree Fern, or upon an artificial pillar. I say it should, because I have never been able to make much progress in its cultivation; the reason I am at a loss to discover, but I shall still endeavour to conquer the difficulty. It has been introduced to our gardens from Borneo, but probably may be found throughout the whole of the Indian Archipelago.

A. TENELLA.—This plant makes a nice covering for the stem of a tree Fern, its creeping rhizome soon mounting to a considerable height, and fixing itself very firmly. The fronds are pinnate, pinnae entire, oblong acuminate, and dark green. It also rejoices in the name of *Polypodium tenellum*, P. filipes, and Arthropteris filipes. It succeeds admirably in a cool fernery. Native of New Zealand.—EXPERTO CREDE.

GROUND LEVELLING AND PRACTICAL GARDEN PLOTTING.—No. 5. DRAWING PLANS.

Fig. 18 is described from an equilateral triangle ABC. From angle c draw arcs d e; divide the space between the two arcs at points f and g with the radius j h and g i, and draw the end arcs, uniting with arcs d and e.

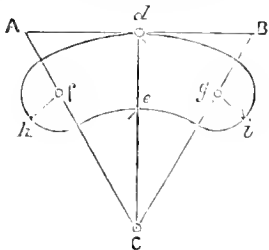

Fig. 18.

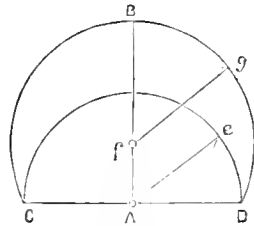

Fig. 19.

Fig. 19.—Draw line c n any length. Bisect it in A, and erect the perpendicular line A B from A with radius A D, which is half c D. Draw the arc as shown in c. From any part of the

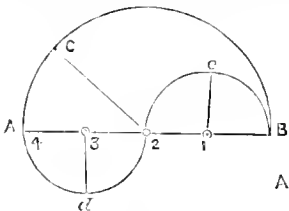

Fig. 20.

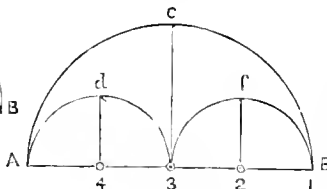

Fig. 21.

perpendicular line A B take a centre, as point f; with radius f b draw the arc as shown in g.

Fig. 20 is drawn from the line A B: Draw line A B any length; divide it into four equal parts, as 1, 2, 3, and 4. With the radius 2, 4, which is half the length of the line, draw arc c; from point 1 draw arc e, as shown by the radius; also from point 3 draw arc d.

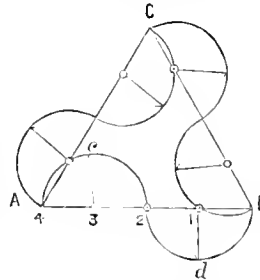

Fig. 20.

Fig. 21 is drawn from line A B in the same way as the above figure. Divide the line into four equal parts, as in the preceding case. With the radius 1, 3, draw arc c. From point 2, draw arc f. From point 4 draw arc d.

Fig. 22 is drawn from an equilateral triangle. Draw triangle A B C. Divide each line into four equal parts, as line A B, as shown by 1, 2, 3, 4. With radius 1, 2, which is one-fourth of the line, draw arc d; with radius 3, 2, draw arc e; and so on with the other sides, and the figure will be complete.

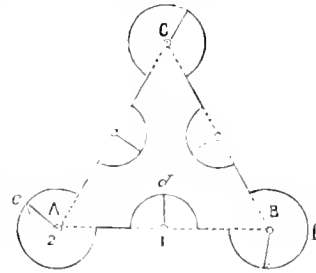

Fig. 23

Fig. 23 is drawn by dividing the sides of the equilateral triangle A B C into two equal parts, as shown by 1 and 2. On line A B, from point 1, which is half the line, draw arc d; from point A draw arc e; from point B draw arc f; and so on with the other two sides.

When the arcs are all drawn, draw the straight lines between the arcs.—M. O'DONNELL, Gardener to E. Leeming, Esq., Spring Grove, Richmond.

NOTES MADE DURING A TOUR IN IRELAND: No. 2.

In the immediate neighbourhood of Dublin there are many fine gardens at the seats of the nobility, government officials, and the wealthy tradesmen. Such gardens are very secluded, so that the passer-by can see little of them; still, though I believe the Irish people may be very fond of flowers, yet about Dublin the visitor is struck very forcibly with the lack of these in the prettily-kept gardens of the smaller villas and the dwellings of the poorer classes about Dublin, in comparison with those round London and other English towns. I wish to see displayed a little more of this popular love and regard for flowers; it would not only enhance the beauties of an already beautiful city, but would give much pleasure to the people generally. The people of Dublin have, however, next to our own royal gardens of Kew, the best botanical garden—viz.,

GLASNEVIN.

My first object after my arrival in Dublin was to visit this famed garden, where I was very courteously received by its talented director Dr. Moore. The botanic garden of Glasnevin is naturally very beautiful; it lies a little to the north of Dublin on the main road leading from Sackville Street through rather a poor low neighbourhood, giving one a rather unfavourable impression of what is to be seen. Once at the gates, however, all this vanishes, and we enter, I should say, one of the prettiest and most interesting public gardens in the world, especially if the visitor has the good fortune to meet Dr. Moore, who is all kindness, and full of much interesting information respecting every plant in the gardens. Here attention is called to a big tree, there to a little Moss, yet the same interest is attached to both. We are told how, when, and by whom each was introduced, and all the ups and downs of their chequered lives. To true lovers of plants there is nothing more delightful than this kind of talk, so with Dr. Moore I was at once at home. The garden, which is tolerably extensive, is very diversified in character, the surface undulating, having many distinct features, and appearing, perhaps, of greater extent than it actually is. No better style of ground could be selected than this for a public garden, yet apart from its natural beauties it is extremely well designed and tastefully laid out, presenting plenty of green trees and green grass, and pretty winding walks. The beauty

and fashion of Dublin flock here on the Sunday afternoon in great numbers; it is their great meeting place, and a very delightful one. From here also we have a good view of the monument to O'Connell, which is chiefly remarkable for its extreme ugliness, yet it is much thought of. A little is done here in the modern style of flower gardening, there being groups and beds of scarlet Pelargoniums, &c., arranged with good taste and effect, yet in no way destroying the principles of the place as a botanic garden. Botanic gardens, pure and simple, are very dry and uninviting places to the unscientific portion of the people, and there is nothing, I think, more ugly and disappointing than the arrangement of plants in strict botanical fashion. At Glasnevin all are harmoniously and pleasantly blended; it is a true botanic garden, yet every part of it is pleasing and interesting.

The collection of plants both under glass and in the open air is very extensive and varied. There is a considerable number of glass houses, which are very good substantial buildings, well adapted for the purposes for which they are designed, not excepting the large Palm stove itself, although it is, perhaps, one of the ugliest glass structures erected in any country, it having, when viewed externally, more the appearance of a huge overgrown barn than anything else. It is, nevertheless, internally well adapted for its occupants. The height of this hideous pile is upwards of 60 feet; it has a very steep span roof, and one end is of brick, with a chimney as in the gable end of a great farm house. Say what one may about its fine contents and its suitability for them, it is a sad, a great disfigurement to an otherwise almost perfect garden. I believe it cost for erection about £2000, for which sum, although miserably inadequate, it would surely have been easy to have produced a better design.

Coming now to the contents, I am all admiration. There are some splendid examples of Palms of great size and in full health and vigour. One, a species of *Coccos*, was more than 50 feet high, and truly noble; *Latania borbonica* with its great shield-like leaves was also very large. So were several species of *Cycas*. We find here some noble tree Ferns, as *Cyathea elegans* and *serra*, 15 feet, with large and beautiful fronds, *Alsophila Cooperi*, &c.; but I must not particularise amongst so many. In addition to this there are other large houses for Palms, forming a portion of a long mixed range of rather lofty half-curved-roofed houses. In one of these is a specimen of *Phoenix dactylifera*, with a huge spreading head, and a stem upwards of 2 feet in diameter; *Chamærops Martiana*, 20 feet; and a fine specimen of *Chamærops chinensis*, or *Hemp Palm*, a very distinct and unique Palm. There were also very fine plants of *Corypha australis* and *Jubæa spectabilis*, the latter Dr. Moore stated to be quite hardy. I noticed here a fine plant of the *Bonaparteæ* in flower, which was very handsome. In another house were some fine Cactuses and a large plant of *Cereus Russellianus*; also a Mango tree laden with fine fruit, which, I was told, ripens off admirably. There were also some fine plants of *Brownea grandiceps* with their curious tufts of newly developed leaves, which give it such a singular aspect.

Although not, perhaps, in the order in which they stand, I next come to the Victoria house, having a ridge-and-furrow roof. The Lily looked well, the leaves were large, and it had several flowers. There were here several large plants of *Nepenthes*.

In other houses we find a fair collection of Orchids in good condition, and a great number of seedling *Nepenthes* and *Sarracénias*, than which there are no more beautiful and interesting plants, especially when in the young state. Next we enter a large New Holland house, where there is a fair collection of these plants, also of *Agaves*, *Sempervivums*, &c.

I have yet to notice one of Glasnevin's greatest features in the plant way—namely, its collection of tree Ferns. They are here in great quantity and variety, and for the most part looked well, but I fancied they would have liked a little more heat. In a small circular house there is a truly handsome specimen of *Cyathea medullaris* over 20 feet in height; there are also imported plants of *Alsophila australis* and *exelsa* with stems over 8 feet high. What must be the age of Ferns like these? If they do not produce stems more rapidly in their native country than with us, they must be very aged. A plant of *Cyathea debata* over twenty years of age, with Dr. Moore is only now beginning to form a stem: when will it be 20 feet high? This is in tree Fern house No. 2, where we find a large lot of fine fellows, as *Dicksonia antarctica* with a 5-foot stem grown at Glasnevin; another of the same branching into three stems; *Cyathea medullaris*, slender-foliaged; *Alsophila Cooperi*;

Dicksonia squarrosa, *C. Cunninghamii*, *C. Smithii*, and *Leichardtii*, all very distinct and graceful. How very noble these tree Ferns look, and how striking an effect have they in our plant houses when judiciously placed with other things! Outside, against the walls of one of these houses, I observed a very beautiful and, to me, strange plant for the situation. It was no less than *Clerodendron fœtidum*, with its great panicles of reddish purple flowers. It is there a hardy plant. In a little pond by the door I observed some fine examples of the *Limnæcharis Humboldtii* and the curious *Trapa natans*.

At the back of one of these ranges Dr. Moore is now erecting a lean-to having a northern exposure for the growth of *Hymenophyllums*, *Selaginellas*, *Todeas*, &c. There is to be a walk down the front of the house, then the bed about 8 feet wide up to the back wall, on which the plants will be placed in a slightly rustic style, and this then is enclosed by a glass partition formed of sliding moveable sashes, so that the plants are in a close glass case. This will be far better than the tiresome bell and hand-glasses, through which no one can ever see the plants. Dr. Moore has a choice collection of the above plants, which, when once properly displayed, will prove very attractive. In some low propagating pits I noticed many choice little things, and in particular a new *Anthurium* named *pedatum repandum*, and the pretty *Drosophyllums* and *Droceras*, or *Sundews*, wonderful in the extreme.

In the open ground I was pleased to find our old mixed border of herbaceous plants, which is always so full of interest. Here I noticed many choice gems which I should have liked to have called. The pretty little Daisy-like *Vittadenia trilobata* I had not before met with, although it is no new thing. In the front of the chief range of houses, and along each side of one of the main walks, this mixed border of herbaceous plants was continued, along with a very large and fine collection of *Saxifrages*.

Coniferae occupy a prominent place, and there are many interesting and fine specimens. *Abies Smithiana* was 25 feet high. There was a very large and fine plant of the *Golden Yew*, as well as a curious naked-growing form of *Cupressus californica* which I had not before met with. A Cedar of Goa had been raised from seeds which had been kept eighteen years—rather a remarkable instance of vitality in resinous seeds.

More and yet more I could tell of the treasures of this place, but I would just notice the fine collection of trees, Oaks especially, and one variety in particular, *Quercus Louettii*, truly a charming tree. In the nursery grounds attached, where Dr. Moore first proves the value of the trees and shrubs before putting them out in the grounds permanently, I observed many fine trees; one a Chestnut—*Castanea vesca pumila heterophylla*, was particularly striking. My attention was called here to an example of the *Orobanche* growing on the Ivy—not naturally, however, but, as Dr. Moore informed me, grafted on it purposely by Dr. Moore himself. It was growing with its usual character. I have never heard of this being done before. I look upon it as rather a horticultural triumph.

I hold Glasnevin in great estimation. It stands high in the list of botanical gardens, and it is pre-eminently a beautiful and enjoyable spot. Dublin may well be, as she is, proud of her Glasnevin, and of the high, honourable, and just estimation in which is held its talented director, Dr. Moore.—B.

THE NEW GLADIOLUSES OF 1870.

As several communications have reached me relative to our prospects of new Gladioli, I am sure that those few who know my excellent friend M. Sonchet will be glad to have some intelligence of him and his bulbs. I therefore subjoin a translation of some extracts from a letter I have just received from him.

“Up to this time our city has not suffered from the presence of the enemy in our country. Many columns of Prussian artillery, cavalry, and infantry have passed through our town without stopping there. They have not done us any injury, but all the country comprised within a radius of twenty leagues around Paris has been devastated. Our communications are often interrupted; but doubtless you are better informed concerning the events of the war than we are. We have no news of our friends living in the suburbs of Paris, especially of those who have left their homes. Where they are or what has happened to them we are utterly ignorant of. This anxiety, added to that of the final result of the bloody strife which we are now engaged in, and the cessation of the ravages wrought by the Prussians, sadly distress us. At the same time we have not

lost all spirit. Our courage, though shaken, will be restored, and, if time be given to us to complete and utilise our armament, men of earnestness will not be wanting to take the offensive. Unhappily our beautiful country is so disorganised and divided by party that our efforts are often paralysed.

"As for myself, I cannot regain my strength, and I had great difficulty in marking my Gladioli. I esteem myself very fortunate in having been able to take them up and store them in good time and in capital condition. Unfortunately, the war hinders our orders. We have been so harassed that I do not know whether I have sent you a list of my novelties, and therefore send one in this letter.

"If after the war we are enabled to execute any orders I shall be able to send out these novelties; but if not, I shall be obliged to call the novelties prepared for 1870-71 those for 1871-72.

"We hear that an armistice has been proposed by England. May God grant that it may be accepted, and that peace may be soon concluded."

He sends me a list with descriptions of the novelties coming out this autumn. There are in all twenty, bearing the following names:—

1. Aramis.—Rose, slightly shaded with orange and margined with cerise.
2. Athalie.—Violet, slightly shaded with rose; flamed purple.
3. Colbert.—Red cerise, slightly shaded orange.
4. Conde.—Reddish orange.
5. Coralie.—White, shaded rose and yellow.
6. Edith Dombriau.—White, very largely flamed with deep carmine, stained carmine purple.
7. Horace Vernet.—Brilliant red purple; pure large white stain, striped red.
8. Ida.—White ground, very slightly tinted with rose; flamed rose carmine.
9. Lamarek.—Cerise, slightly shaded orange.
- 10.—Nestor.—Clear yellow; lower petals deeper yellow striped with red.
11. Phidias.—Very brilliant purple, slightly tinted violet; large pure white stains, finely striped with carmine cerise.
12. Phire.—Ground pure white, largely bordered and flamed rose.
13. Primature.—Very long spike of rose-coloured flowers, slightly tinted with lilac; flamed bright carmine.
14. Redonete.—Beautiful rose, slightly tinted with violet.
- 15.—Sappho.—Very beautiful cerise colour, shaded orange.
16. Sir J. Franklin.—Very beautiful satiny rose; all the petals lined white.
17. Talisman.—Beautiful violet, largely bordered with bright cerise.
18. Van Spanlowk.—Very striking red.
19. Zelinda.—Very beautiful bright rose; largely flamed deep carmine.
20. Zenobia.—Rose, very slightly tinted with violet; flamed deep carmine.

Of these 6, 7, 11, 12, 13, 15, 16, and 17, seem from their price to be the best; but we must wait, for not seldom we are obliged to reverse the decision come to on the other side of the Channel.—D., *Deal*.

PLANTING WHOLE POTATOES.

A NEIGHBOUR of mine, whom I will call B, and I, each invested last spring in a hundredweight of Paterson's Victoria Potatoes. They were very large, so B decided to cut his in two, but I preferred planting mine whole. I wrote to you on the subject last June, and you replied to me in your number of the 2nd July, page 16, requesting me to let you know the result. I now do so.

The cut and uncut sets were planted in the same field side by side, and equally manured. It was a very long field, and as my uncut sets were sufficient to plant one row, of course B's planted two rows. My row yielded 8 cwt., and B's two rows yielded only 7 cwt. between them. I conclude, therefore, that by cutting his sets instead of buying another cwt. to plant in the second row, that B lost 9 cwt. of Potatoes, or the sum of 40s., calculating them at 5s. per cwt., the price we gave, and allowing for the extra cwt. for sets.

Many of the cut sets missed owing to the dry season, and although B does not think the trial a fair one, he says he means to plant whole ones in future.

Mr. Fenn and most of the authorities on Potato culture advise planting whole Potatoes, but the accounts you have lately been publishing of the yields of the Early Rose and Bovinia Potato sets cut into the smallest pieces are sufficient to shake anyone's faith in the practice. One gentleman cut a Potato of 1 lb. weight into nineteen sets, the produce being

133 lbs. Query, If this Potato had been set whole in a hill with plenty of room, would the produce have been greater? This question wants ventilating. Will some of your correspondents give us the benefit of their experience?—CALCRIA.

MAIDSTONE GARDENERS' IMPROVEMENT ASSOCIATION.

SEVEN or eight years ago a few gardeners in the neighbourhood of Maidstone met, with the view of making arrangements to secure a room in which they might assemble at stated intervals and discuss subjects connected with their calling. A number of members enrolled themselves in what was called the Maidstone Gardeners' Mutual Improvement Society, and a set of simple rules was framed, one of which stated that a general meeting was to be held once a-month, and an ordinary meeting in the intervals between the general meetings. At both plants, fruits, vegetables, or anything connected with gardening might be shown by members and commented upon; or any gardening subject might be brought forward by a member on giving proper notice, and every facility was given for any member disposed to speak, some officer of the Society occupying the chair.

The success which attended these meetings was very great, and the interest taken in the matter by others not connected with gardening led many to become honorary members, so the Society resolved in the winter of the second year of its existence to hold a show, or rather arrange a display of plants, fruits, and vegetables in the Corn Exchange, the largest building in the town. To render it more attractive, the room was decorated with wreaths of evergreen, and other horticultural devices, and a small charge being made for admission to non-members, a handsome sum was added to the funds of the Society. Its importance seemed now to have outgrown the few simple rules at first framed for its guidance, and a new set was prepared, which, amongst other clauses, empowered the Society to afford its members pecuniary assistance to a limited extent when overtaken with sickness, and to grant a sum not exceeding £10 to the representative of a member at his death. In addition, when the funds would allow, the sum of £20 was to be apportioned for the Society having a holiday somewhere once a-year. Now the latter two items seemed large sums from a Society that only required a subscription of 4s. a-year from its members, yet such has been its success that it has always met its engagements, and I believe at the present moment it has between £200 and £300 in hand, although death has called off three or four of its members, each of whom have had the sum I have stated, and the yearly holidays have always been carried out in the summer. Thrice the excursion was to the Crystal Palace, once to Hampton Court, and once to Kew, terms being made with the railway company to take the Society at a stipulated price, the members paying about 1s., and the others 4s. for their tickets, and heavily loaded trains have always been the result.

If this could be done in a town like Maidstone with scarcely 25,000 inhabitants, the question naturally arises, Can it not be done elsewhere? The Society has every spring held a show in the Corn Exchange without giving prizes, it being simply an exhibition in which everything is arranged for effect. Vases, extempore fountains, and other things are fitted up by willing hands under the superintendence of an arrangement committee, and every season a change is made in the arrangement. Music is also provided; and as the exhibition is kept open in the evening, the working classes of Maidstone and its suburbs have an opportunity of seeing it, and are no doubt stimulated by the example, for more than one of the neighbouring villages has its Gardeners' Mutual Improvement Association, where meetings in some degree similar to those of the parent society take place.

The exhibitions generally attract many visitors, and the sum of £100 has been taken at the door on one occasion, but of course there is considerable expense; still, there is always a surplus, which goes to the funds of the Society.

It is, however, the monthly meetings, when matters relating to horticulture are discussed, that appear more than anything to have given the Society so firm a hold of public support. At these meetings it is usual for the President of the Society to take the chair, and as notice has been given at the preceding meeting of what is to be brought forward—generally two or three subjects—one of them is opened up by the person who gave notice of it, and discussion generally follows. It is also not unusual for members to bring fruits and other productions to obtain

the names and other information from more experienced members. These meetings are usually well attended, from forty to double that number being often present, and on special occasions more than that. The Society, I believe, consists of upwards of four hundred members, nearly one-half being immediately connected with gardening, and classed as gardeners; the others are honorary members. Mr. Frost, formerly gardener at Preston Hall, but now a nurseryman in Maidstone, is President. The other officers are chosen from gardeners of good standing in the district, and I believe that all has hitherto worked well, which is much to say of any society. The good feeling shown towards the Society, coupled with the prudent counsels of some of its chief officers, have so far prevented anything like discord, and financially, as well as in other respects, the Society stands in a better position than it ever did.

These observations, explanatory of the working of the Society, are intended to introduce to the readers of THE JOURNAL OF HORTICULTURE another move the Society has made. The previous exhibitions have always been held in the spring, when plants were the principal attraction, and the show of last April certainly exhibited no falling-off from those of former years; but it was thought an autumn fruit show would be an acquisition, and accordingly one was arranged for October 12th, and was in every respect a success, upwards of 1200 dishes of fruit being set up, representing everything of the kind to be met with at a metropolitan show, and many of them in as high a degree of perfection as they well could be. The Apples and Pears were especially fine, as might be expected in a county where so many are grown. One grower sent fifty-two dishes of Pears, all different, and about half that number of Apples; another had upwards of eighty dishes of fruit all carefully named; while smaller contributions were no less commendable by their quality, size, and perfection. Not the least remarkable objects in the Show were the excellent samples of out-door Grapes, and still finer bunches were exhibited from under glass. The Show also comprised Pines, Peaches, Plums, and Damsons, Melons, Figs, Cherries, Strawberries (from the open fields), Raspberries, Gooseberries, Currants, Quinces, and Medlars, as well as Apples, Pears, and Grapes, and some rarities, as Bananas, fruit of the Passion-flower, &c., and two or three exhibitors had dishes of Apples of 1869 in good preservation. Vegetables were equally well represented. Mr. William Luckhurst, at Lord Romney's, The Mote, sent an excellent collection, as also did Mr. Lee, gardener to J. Whatman, Esq., M.P., while the contributions from others were not less remarkable. Plants were but sparingly introduced, only a few being placed along the centre of the tables in the middle of the room to divide the collections. The vegetables occupied the side tables. Taken altogether, the Show might be regarded as one of hardy fruits, such as few districts could furnish, and one of which the members of the Maidstone Gardeners' Mutual Improvement Society felt a little proud, for 1200 dishes of fruit are not collected together every day.—J. ROBSON.

PITCHER-PLANTS.

DIFFERENCE of opinion has been expressed as to the nature and use of the liquid found in the so-called pitchers of various plants, such as *Nepenthes*, *Rafflesia*, and certain *Orchidaceæ*. The popular idea that these curious receptacles collect pure water for the refreshment of the thirsty in arid places, would seem to be set at rest by the consideration of the fact that these plants grow in moist and marshy places. There would seem, moreover, to be some improbability that plants should secrete pure water.

In this country, where these plants are grown under exceptional conditions, there is some difficulty in settling these questions experimentally. In such cases extraneous water often finds its way into the pitchers, so that several ounces may frequently be gathered from a single receptacle of *Nepenthes*, the greater part of which is accidental.

In August last I had an opportunity of collecting the liquid from two flowers of *Coryanthes*, one of the *Orchidaceæ*, which had just opened, in one of the well-known stove houses of Mr. Wilson Saunders.

Though the quantity collected was small, amounting only to about 3 cubic centimetres, or 1.18 cubic inches, an examination showed the following properties:—

Clear and somewhat glutinous in consistence. Possessed of a high refractive power, and a specific gravity of 1.062.

Oudour pleasant but faint, becoming more marked by a gentle heat. Neutral to test papers. Becoming milky, by concentra-

tion on the water-bath, it finally yielded a transparent gum insoluble in alcohol.

Oxalates produced no precipitate of lime, but basic lead acetate gave a curdy reaction. Concentrated hot sulphuric acid blackened the liquid.

Although the taste was not acrid, the mawkish flavour would render it quite unpotable.

This examination therefore proved the liquid to be something else than pure water.

100 parts of liquid contained:—

Water and volatile oils	98.51
Non-volatile residue.....	1.49
	100.00

—G. B. BUCKTON.—(Nature.)

CONSTRUCTING AN ICE-HOUSE.

ABOUT three years ago my employer wanted to do away with the ice-house. It was too near the residence. He thought he should like a square one. I showed him the sketch of that in one of your numbers of July, 1864, and he thought it was just the house he should like. We set to work and had it built, and we have filled it twice, but when we came to open the house, which we do not want to do until about the second week in November, there was not a bit of ice left either time. Of course, it is a great disappointment. I see that the sketch in your Journal is by Mr. Fish; if he would give me his advice I should be obliged. You will see by the accompanying outline of the house (which is 10 feet wide, 14 feet long, and 9 feet deep), that I have had a drain pipe put in at each corner, so that the air may pass all round between the walls. The roof does not come to the ground, for I have the air passing in and out by the sides.—G. Y. M.

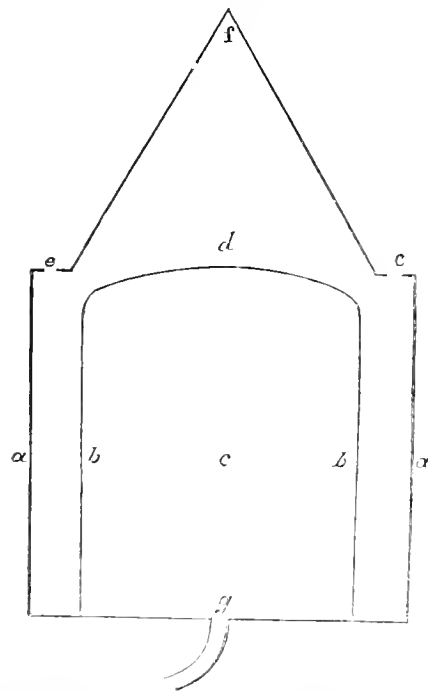

a, a, Outside 9 inch wall.
 b, b, Inside 4½-inch wall.
 c, c, Well all below ground.
 d, Arch.
 e, e, Drain-pipe.
 f, f, Roof.
 g, g, Drain.

[We are sometimes asked the cause of failures, when we can give no better reason than that known to the inquirers, and thus we are often reminded how little we know. In the present case we feel rather pleased, not that there has been a disappointment, but that we think we see how it may be prevented in future.

We may first remark, that it is next to folly to suppose that in wells whether circular or square, or even in stacks above ground, ice can be long kept in small quantities. This is trying to an ice-house not opened until November. The house described is rather small for such late work. We should have

liked it better if it had been 14 feet square, instead of 11 by 10, and as much in depth, instead of 9 feet. However, the size is not the chief cause of failure. That we believe is owing to the free access of the air in summer all round between the outer and the inner wall. The heat of the surrounding ground, and the heat of the warmest air in July and August, have thus had free play on the 9-inch wall surrounding the ice. For practical purposes, the ice-house might almost as well have been a building with a 9-inch wall above ground. The great advantage of the double wall is to enclose a body of *still* air, and then that air is a non-conductor of heat. It loses that quality when it is not confined. We would first, then, shut up *all* the air-openings between the two walls; in fact, be quite as anxious to keep a breath of fresh air from getting there, unless, indeed, it were a severe frost, as you would be to admit air into your own bedroom. It is on the complete isolation of that air that its non-conducting power depends.

Secondly, if the roof does not extend to the ground, bring it over the outside wall so that the drip shall fall considerably beyond it. Thirdly, in such a house we would use no straw for packing, but pack the ice at once against the inside wall. When finished we would place a layer of clean dry straw on the surface. As the days lengthened in spring we would open the house, and if the straw were at all damp we would remove it and replace it with fresher, and do so again if necessary.

If, as the days became very warm, on opening the ice-house there should be any appearance of misty vapour, which sets rapidly on ice, we would have one or two small openings in the top of the doorway, say an inch in diameter, furnished with a cork so as to let this vapour out when present, and keep the holes shut when there was no vapour. A pipe coming out at the roof would even be better to be stopped at pleasure. In a house of the size referred to, keeping ice will greatly depend on having the air over the ice dry, whilst the ice itself is not directly exposed to it. We believe the chief cause of failure is the air moving in the open space between the two walls. We presume the drain from the bottom is trapped.—R. F.

STOKE NEWINGTON CHRYSANTHEMUM SOCIETY.

This Society's twenty-fourth annual Show was held on the 15th and 16th inst., in the New Assembly Rooms, Detoe Road, Stoke Newington. The specimen plants were arranged in the orchestra, and there proved very effective as a whole, while individually they were without exception of high excellence, as may be imagined from the fact of several of them having from seventy to eighty blooms. The best six came from Mr. Drain, Southgate Nursery, De Beauvoir Town, and consisted of Prince Albert, Annie Salter, Christine, Little Harry, Alma, and Mrs. G. Randle. Mr. Forsyth, of the Brunswick Nursery, was second, with fine plants of Golden Christine, Mrs. G. Randle, Dr. Sharpe, Prince of Wales, Lady Harding, and Annie Salter. The third prize went to Mr. Little, Cambridge Park, Twickenham, who had tall-stemmed plants, which are less effective as specimens, but with very fine blooms. For three plants Mr. Drain was again first with Mrs. G. Randle, Dr. Sharpe, and Prince of Wales, Mr. Forsyth being second.

The specimen Pompons shown in Classes 3 and 4, respectively for six and three plants, were also excellent. Mr. North, Manor Lane, Lee, and Mr. Forsyth, had the best sixes, consisting of the different kinds of Cedo Nulli, Bob, Salomon, and Golden Circle. Several of these plants were a yard across, and a mass of bloom. Mr. Monk was third. The prizes for three plants went to Messrs. Monk, Butcher, and Forsyth. Standard Pompons, as shown by Mr. Howe, of Shacklewell, were admirably grown and bloomed. They were about 4 feet high, and with heads nearly a yard across. The varieties were Bob, White and Lilac Cedo Nulli, Mustapha, Golden Aurore, and Antonius. Messrs. Monk and James were respectively second and third.

Cut blooms were very well shown, perhaps on the whole not so large as in some years, with the exception of White Globe, Queen of England, Empress of India, and a few others; but the blooms shown by Messrs. Rowe, Slade, and Monk were not only of remarkable size, but very perfect. The first prize for twenty-four was taken by Mr. Rowe, of Roehampton, with Empress of India, Prince Alfred, Princess of Wales, Bronze Jardin des Plantes, White Globe, John Salter, Queen of England, Prince of Wales, Mr. Gladstone, Plutus, Nonpareil, Lady Slade, and others also fine, though those named were the most conspicuous. The other prizetakers were Mr. Slade, Mr. Sanderson, and Mr. Drain.

For twelve blooms Mr. Rowe was also first with magnificent

examples of Empress of India, White Globe, Queen of England, Prince Alfred, Miss Mary Morgan, Lady Slade, Nonpareil, Rev. Joshua Dix, Empress Eugénie, Prince of Wales, Princess of Teck, and Jardin des Plantes. Mr. Monk, who was second, had also a very fine stand.

SUBSTITUTE FOR GRAFTING WAX.

Not long ago, the Mastic l'homme Lefort, or cold grafting wax, was first brought under our notice, and this we have found exceedingly handy when grafting small things, on account of its being ready for use at all times. Latterly we have been using another material, which for certain purposes is infinitely more handy, superseding, indeed, not only the grafting wax, but the very matting or string by which we tie graft and stock together. This material is nothing more nor less than sheet indiarubber. It was Major Clarke, than whom there is no greater nor more original horticultural experimentalist, who first called our attention to it, and it is really very wonderful how handy it is. Indiarubber may be purchased, in sheets of about the thickness of brown paper at some of the London shops which deal in articles of that class for a mere trifle—6d. or 1s. the square foot. The undressed sheets are the best. Before using it wash it in clean water, and dry it by dabbing it with a handkerchief or cloth.

The sheets are cut as required into pieces of about an inch in length, and about an eighth of an inch in width, according to the space to be covered, and the little band so formed is twisted round in the same way as a piece of matting would be, and, of course, elongates considerably, encompassing the stem two or three times. The end is simply yet securely fastened, by just pressing it firmly into the other with the thumb nail. This forms it into a simple elastic band, which keeps its hold as long as required. For grafting choice little enjoints, and for delicate operations, the small strips of sheet indiarubber are extremely handy and useful, and far more easily fitted than a piece of matting.—A. F. BARRON.—(*Florist and Pomologist.*)

PAULLINIA SORBILIS.—In a recent number of the *Pharmaceutical Journal* a paper appears, by Mr. Cook, on the Guarana, the seeds of a tree termed the Paullinia sorbilis, belonging to the order Sapindaceæ, and abundant in the province of the Amazonas. The fruit is scarcely as large as a walnut, and contains five or six seeds, which are roasted, then mixed with water and moulded into a cylindrical form resembling a large sausage, and finally dried in an oven. Before being used it is grated into a powder, very like powdered cacao in appearance. Two spoonfuls of the powder are mixed in a tumbler of water, and this drink is regarded as a stimulant to the nerves, and like strong tea or coffee, is said to take away the disposition to sleep. The active chemical principle is an alkaloid, which Dr. Stephenson has shown to be identical with theine. Guarana contains more than double as much of this alkaloid as good black tea, and five times as much as coffee, the proportion being 5.07 per cent. in Guarana. It is rather a singular coincidence that the same alkaloid should prevail in all the principal substances employed in a similar manner as beverages in different parts of the world, in the tea of China and India, the coffee of Arabia, the cacao of Central America, the maté of South America, and the Guarana of Brazil. Guarana is a nervous stimulative and restorative.—(*Nature*)

NOVEMBER CATERPILLARS.

The entomologist has many opportunities for verifying the popular proverb, that "in looking for one thing you find another," so often does he go out intent upon discovering some insect, the locality of which he thinks he knows, and while he fails to get this, lights upon other species he did not dream of finding. Also, while searching for insects in one particular stage, specimens turn up in other stages; when hunting for imagos especially we come across caterpillars, and if seeking caterpillars we very frequently discover chrysalides. Amongst other choice chrysalides taken this month, by what we call a fortunate accident, the insect-hunter, between united leaves of Birch, Beech, or Oak, finds the cocoon of the Lobster Moth, the caterpillar of which we described last month. The chrysalis is without any notable singularity.

The cabinet of the entomologist is not likely to derive much advantage from his researches among the caterpillars in November, for though there are a few which may be taken now

nearly full-fed, and do not require much care or attention to bring them through, the bulk of the hibernating individuals, if brought in-doors, or otherwise placed in confinement, are difficult to rear. But still, those who desire to gain a thorough insight into caterpillar history will devote themselves, as opportunity offers, to the work of seeking for colonies, or isolated individuals, even at a season when such a pursuit is less attractive than in the summer season. And there are certain species, it must be remembered, which may be detected in winter, when the trees are bare and herbage is scant, with more facility than when vegetable life is at its height. Ingenious, too, as are the modes of concealment adopted by some hibernating caterpillars, they ought not to baffle the determined collector entirely, though he may require several successive seasons to pass by ere he can say that he has succeeded in fully elucidating the life-history of some one or other of these.

Amongst these hibernators is one to whose peculiarities I have paid much attention, having at various times reared a large number of the caterpillars. This produces the Moth known as the Scarce Vapourer (*Orygia gonostigma*), and the species is highly interesting because it is so closely allied to the very common Vapourer Moth, which we see dashing wildly about in London suburbs, and in the vicinity of other towns during the summer. The other species is confined to a very few localities, one of which is in Surrey, near the metropolis; and as the female moth is destitute of wings, and cannot journey from place to place, it is not likely to become more common. The caterpillar, by the movements of which alone could it be distributed, is not very migratory; and the circumstance that it lives through the winter, exposes it to various dangers which the common species escapes, since through the cold months it is in the egg state. The caterpillars of the Scarce Vapourer are hatched about the end of July, from eggs deposited in a cluster (sometimes as many as four hundred); and at first emergence they keep pretty closely together, separating from each other by degrees as they increase in size, but they grow very slowly, and soon prepare to hibernate. As is the case with other species, they do not always locate themselves for the winter on or near their food plant, which renders a search for them more difficult. According to my observations, they do not form any protection for themselves, usually resting near the ground on a twig near the centre of a bush. In some cases, they have been found actually on the earth, and observers have reported also instances where these caterpillars had sheltered themselves by weaving a web around a leaf or branch, but this is probably exceptional. Remaining without food until the spring, the caterpillars of the Scarce Vapourer are quite ready in April to commence an attack upon the Sallow or Hawthorn buds, taking afterwards to the Oak or Hazel, which they prefer. The ground colour is a beautiful orange with four rows of black spots coalescing so as to form stripes; from the fifth to the eighth segment we find a brown upright tuft of hair arising from each; the second segment has two long pencils of hairs which point forwards; on the last segment there are three tufts of black hairs, directed backwards. A considerable portion of the hairs are used by the caterpillar in forming its cocoon, and the chrysalis is also hairy.

A very local moth is that called by collectors the Reed Leopard (*Microgaster arundinis*), and it is one of those species which beguile the insect-hunter into the uninviting fenny districts of Huntingdonshire and Cambridgeshire. Like the Swallow-tail Butterfly, each year tends to diminish the numbers occurring, through the reclaiming of the fens. The caterpillar lives from summer until the following spring, and probably feeds through the winter unless in severe weather. It is of a dirty white colour, with a horny head, and a plate of similar texture on the next segment, very much resembling a maggot in appearance. The egg is deposited by the mother moth on the stem of the common Reed, only one being laid on each plant. The young caterpillar at once eats its way to the interior of the stem, and generally works its way upward towards the top of the plant, though it has the power of moving up and down. The chrysalis is long, and has rows of minute hooks, by means of which it is able to change its position if needful, giving birth to the moth in June.

The history of the Black-veined White Butterfly (*Aporia crataegi*) is very interesting. Classified, as it is, with the common Whites, and bearing a resemblance to them in some particulars, it is much scarcer, and differs greatly in its habits. The caterpillars, directly they are hatched, construct a sort of tent, under which they feed, but do not attain any considerable size during the autumn. A similar, though thicker, tent serves

them for an abode through the winter season, when the prying eye of the entomologist, scanning the boughs of the Hawthorn or the Pear, may perhaps discover it, and carry off the colony as a prize. Certain districts in Wales and contiguous English counties yield this species most abundantly in some seasons, and it occurs in Kent near Faversham, and also, it is said, in Devonshire. The caterpillar of the Black-veined White, when full grown, has the head of a smoky black, covered with hairs of two different lengths, the shorter being black, the longer white. The body is a rather deeper black, and it has two rust-coloured stripes, which a moderate magnifying power resolves at once into a number of minute spots; in the centre of each of these there is a black dot, from which springs a rust-coloured hair. Underneath, the surface of the body is grey, sprinkled with black dots, and dotted with whitish hairs. When full-fed, this caterpillar spreads a silken web over the twig on which it has been feeding, and, fixing itself thereto, turns to a chrysalis. Sometimes, however, like its relatives the Whites, it will crawl from the tree or shrub to some wall or paling. The butterfly, which appears in July, flies swiftly by day, but at night is easily taken in those places where it occurs as it rests on the flowers in full view.

A particularly local butterfly is that pretty species the Marbled White (*Argo Galathea*), and as it very seldom flies far beyond the meadow where it was bred, there is some encouragement for the collector to look for the caterpillar, which feeds upon various grasses. It is but small when it hibernates, remaining apparently without eating all through the winter, though some species, also grass-feeders, nibble the blades occasionally if the weather is mild. When feeding, at the least annoyance or alarm the caterpillar of the Marbled White falls from the plant in a curved posture, lying without motion for some time. The head is rough, sometimes green, sometimes brown; the hue of the body also varies similarly, but always a little darker than the head; down the middle of the back is a dark stripe, on each side of this is a narrow stripe, pale red, and just below the spiracles (which are deep black) there is a whitish stripe. The body is stout, rather fusiform, and at the anal extremity exhibits two points, in which all the stripes meet; every part is studded with minute warts and short hairs. No preparation for becoming a chrysalis appears to be made by this caterpillar; descending from its food-plant, it settles low down amongst the herbage, and turns to a short brown chrysalis, partly transparent, from which the perfect insect soon emerges.

In places where the common Broom grows plentifully, we are almost sure to find in November, and through the winter, the young caterpillars of the Grass Emerald (*Pseudoteipna ctyisaria*). Hatched during July, they grow but little in the autumn, and then fix themselves upon the stems of the plant, and with the head raised from the surface they remain unmoved in the coldest weather, re-awakening to life about the end of April. When getting near their full size they rest on the twigs in a singular position, with the head bent under and the legs crowded together and brought close to the mouth. The whole body is covered with small points, as if shagreened, the head being deeply notched on the crown, while from the segment behind it rise two blunt protuberances, which point over the head; on the last segment are two points of a pinkish hue. The general colour of both head and body is dull green, with pink on the crown of the head and the protuberances behind it; a very narrow brownish stripe runs down the back, and along each side is a white stripe, edged with red, which is interrupted on the fourth segment; the spiracles show distinctly, being paler than the ground colour. When these caterpillars have ceased to feed they draw two or three leaves loosely together, and under this shelter become chrysalides about the end of June.

Another hibernating geometer caterpillar, which bears some resemblance to the preceding, is that of the Common Marbled Carpet (*Cidaria russata*); unlike it, however, it feeds occasionally during the winter in mild weather, being then found upon or near the wild Strawberry, in the summer it has also been detected on Birch and Sallow. This caterpillar rests usually with the body extended, but, if touched, at once raises its head and bends it under, in the "volute form." The head is of a rather duller colour than the body, the eyes, which are black, showing conspicuously; the body pale yellow-green, with a stripe of dark green down the back. In some specimens there is a beautiful purplish stripe along the sides. All over the body are minute white warts, each giving off a hair; at the anal extremity are two protuberances, usually rose colour; the legs and claspers are of a dull red colour. The individuals of this

species which have lived through the winter turn to chrysalides in May, and there is a second brood of the caterpillars in June and July.

The curious caterpillar of the Scalloped Bar (*Scodiora Belgaria*) occurs on heath, and is rather uncommon. It may be looked for at this time on patches of the common Ling, near the roots of which it remains in a state of hibernation, rousing itself to eat in April. When alarmed it rolls into a ring, and will remain thus coiled up for an hour. In colour it is brown, with indistinct greyish markings, and a short white stripe near the first pair of claspers. On each segment there are two warts on the back, and there is a conical short horn above the anus, behind which are two longer and slender horns, which are usually pressed closely together. The female caterpillars are perceptibly less in size than the males, a rather unusual circumstance. The cocoon is spun upon the ground; it is of slight texture.

On various heaths and commons, though less abundant now than formerly, we find the caterpillar of the Clouded Buff (*Euthemonia russula*), which, though hatched from the egg in July, does not become adult till the following May. Its favourite food-plants are the Monse-ear Hawkweed and the common Dandelion. At this time it is about one-third grown, and is dull brown in colour, with hairs of a reddish brown, and a faintly indicated stripe down the back. When the weather is favourable it appears to feed on various low plants, as does also the caterpillar of its handsome relative, the Wood Tiger (*Chelonia plantagenis*), so named from its partiality to plantain. Clearings in woods yield this species, especially in the south, and the caterpillar may be detected in the winter season by the persevering insect-hunter. It is of a greyish black tint, dotted over with numerous warts, and covered with long hairs, which increase in length towards the anal extremity, being black in colour at the head and tail, and reddish brown on the middle segments. In its habits it appears very sluggish, and is also the moth, which is rarely seen on the wing.—J. R. S. CLIFFORD. —(*English Mechanic and World of Science*.)

PORTRAITS OF PLANTS, FLOWERS, AND FRUITS.

ENOTHERA WHITNEYI (Whitney's Evening Primrose). *Nat. ord.*, *Scrophulariaceae*. *Limn.*, *Ocoteandia Monogynia*.—"The most splendid of all the species." Flowers pale pink, blotched towards the claws of the petals with purplish crimson. Native of Shelter Cove, Humboldt County, California.—(*Bot. Mag.*, t. 5867.)

SERAPIAS CORDIGERA (Heart-lipped Serapias). *SERAPIAS LINGUA* (Tongue-lipped Serapias). *Nat. ord.*, *Orchidaceae*. *Limn.*, *Gynandria Monandria*.—Natives of all the countries bordering the Mediterranean except Egypt. Flowers deep French white; lip of *S. cordigera* dark purple; and of *S. lingua* crimson.—(*Ibid.*, t. 5868.)

ARISTOLOCHIA BARBATA (Bearded Birthwort). *Nat. ord.*, *Aristolochiaceae*. *Limn.*, *Gynandria Hexandria*.—Native of Venezuela. A very graceful twiner. Flowers pale green and reddish brown, lip clothed inside with purple bristles like a beard.—(*Ibid.*, t. 5869.)

GREVILLEA BANKSI (Sir Joseph Banks' Grevillea). *Nat. ord.*, *Proteaceae*. *Limn.*, *Tetrandria Monogynia*.—Native of barren hills in Queensland, Australia. Flowers crimson and yellow.—(*Ibid.*, t. 5870.)

DODECATELON MEADIA var. *FRIGIDUM* (Arctic American Cow-slip, or Shooting Star). *Nat. ord.*, *Primulaceae*. *Limn.*, *Pentandria Monogynia*.—Native of mountain slopes from latitude 35° N., in California to the Arctic seacoast. Its flowers are usually lilac and white, but sometimes crimson and white, and even entirely white.—(*Ibid.*, t. 5871.)

ALPINE AURICULAS.—*John Leech*, *Selina*, and *Monarch*.—"Seedling Alpine Auriculas have been one of the specialties which, during the last three or four years, Mr. Turner, of Slough, has been in the habit of exhibiting at the spring shows at South Kensington; and rich and varied in colouring as they are, it is no matter of wonder that they should generally have acted on the admiring crowd as one of the principal centres of attraction. Certainly, few groups of flowers could have been more truly beautiful, while in their beauty few could have more thoroughly combined the elements of simplicity and gaiety; and when to this is added the fact that improvement is manifestly going on amongst them, form and colour proportions being moulded to the florist's standard, who can wonder that the Alpine Auriculas (with the self, perhaps) should, on ac-

count of their more decided and richer hues, prove more popular, at least in general public assemblies, than their grotesque brethren, the greens, the whites, and the greys?—though even these we are glad to see meet with more attention and more admiration than they did a few years ago, and might probably again become popular, if growers could be induced to cultivate them, and exhibit them more freely.

"*John Leech* is a rich shaded crimson, smooth, and well proportioned, and one of the richest flowers in its class. *Selina* is a velvety shaded purple, with white paste, and in this feature approaching the ordinary self-coloured varieties. *Monarch* is another purple, with rich shading, and of remarkably fine shape and proportions, doubtless one of the best in its class.

"Not only on account of their highly-coloured and richly-shaded flowers, and the lively contrast afforded by the usually yellow colour of the paste, but also on account of their more vigorous constitution and freer habit of growth, these Alpine Auriculas are likely to rise in popular favour."—(*Florist and Pomologist*, 3 s., iii., 241.)

NIGHT SOIL AS A MANURE.

I NOTICED in last week's Journal that, in answer to an inquiry of one of your correspondents, you spoke very highly of night soil as a manure. This induces me to ask your kind assistance to enable me to overcome a difficulty I experienced last summer through using night soil. I purchased one of the recently-patented "earth closets," the soil from which I applied to my Cabbages, a portion of one of my Onion beds, and a row of Scarlet Runners, and nothing could exceed the very favourable appearance of these crops at first, as they were very considerably in advance of crops planted at the same time, to which I had put stable dung only; but on approaching maturity I first noticed several of my Cabbages begin to droop, and on pulling them up to ascertain the cause, found that the whole of the root had been eaten away by a small white maggot, and nearly the whole crop of Cabbages, Onions, and Beans, to which this manure had been applied, was destroyed by them. I should, therefore much esteem any assistance you may be able to afford me with a view to preventing this.—HOWARD.

[We do not think that the night soil caused the occurrence of the white maggots, but the protracted dry season. Watering and mulching over the roots on each side of the Scarlet Runners, and copious waterings of the Cabbages and of the Onions after the bulbs began to swell, would have kept away the maggots. We grow Onions in rows, with a gutter between each two rows, and in those gutters we pour about once a-week house sewage mixed with water.—EDS.]

THE PLANTING AND LAYING-OUT OF THE THAMES EMBANKMENT NORTH.

SOME of our readers may remember that portion of the north bank of the Thames which extended from Whitehall Stairs to Waterloo Bridge; and those of them who are ignorant of the former condition of that now-transformed region will, perhaps, care to be told that it was a wide extent of malarious mud, varied here and there by the hulks of dilapidated barges, the carcasses of dead dogs, and sundry other articles which go to make up the flotsam and jetsam of our great tidal river. Why that great mudbank should have been suffered to exist so long after civilisation was supposed to have been introduced among us some member of the Thames Conservancy Board may, perhaps, be able to enlighten us; but the only apparent object of the mud conservancy was that it might afford a source of fun and recreation to the herd of mudlarks who burrowed in the Adelphi Arches, and sought shelter in the stairs and passages of old Hungerford Market, much as parks and pleasure grounds are reserved in the present day for the health and recreation of the population. What high holiday these little mudlarks enjoyed! It was perpetual holiday with them. It mattered not what heavy thoughts weighed down the careful city man as he passed along the old shaly barge-borne gangway to the "penny boats," the little mudlark, gambolling in what seemed his native element, bailed him with his cheery though inexpressibly dirty face, grinning from ear to ear, and with the winning request, "Chuck us a penny, sir," he melted the moody man into acquiescence. Oh, the effect of that "chuck!" Away went half a dozen ragged little rascals up to the thighs in black ooze, straight as arrows to their mark. Then came the struggle, the pushing, and the wrangling, and at last the coveted

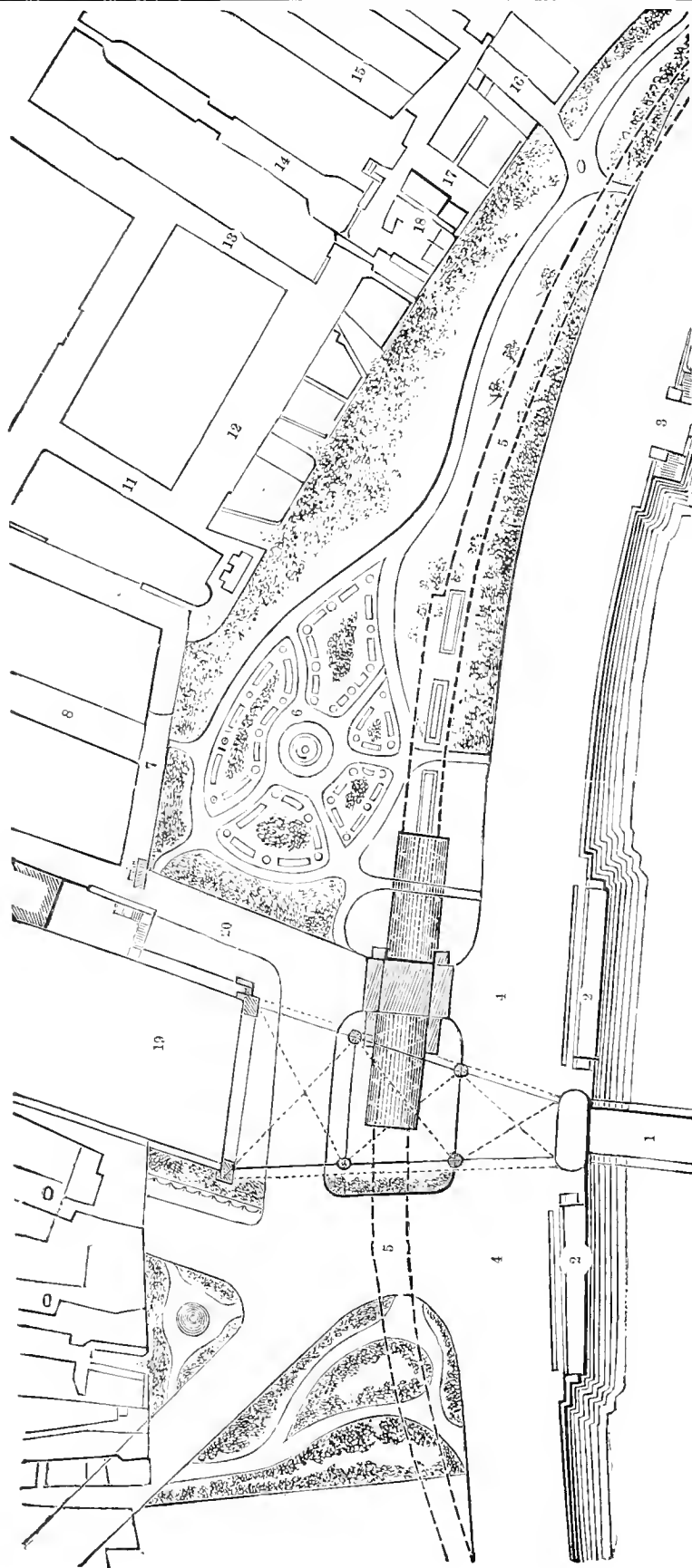

- 1.—Charing Cross Bridge.
- 2.—Steam Boat Pier.
- 3.—Adelphi Stairs.
- 4.—Embankment Roadway.
- 5.—Metropolitan District Railway.
- 6.—Fountain (projected).
- 7.—York Terrace.
- 8.—Buckingham Street.
- 9.—George Street.
- 10.—Adelphi Wharf.
- 11.—Robert Street.
- 12.—Adelphi Terrace.
- 13.—Adam Street.
- 14.—Salisbury Street.
- 15.—Cecil Street.
- 16.—Beaufort Wharf.
- 17.—Salisbury Wharf.
- 18.—Brown's Wharf.
- 19.—Charing Cross Terminus.
- 20.—Villiers Street.

prize was gained frequently not without a disputed ownership which ended in a general scrimmage.

But those days, like all "good old days," are gone, and the mudbank and mud-larks with them. The Metropolitan Board of Works has covered over the mud in making the Thames Embankment, and the mud-larks, let us hope, have either become industrious eboelacks or enterprising colonists. And where the mud was, the genius of gardening has taken possession. Within these few months, under the direction of Mr. McKenzie, and in execution of his design, a garden has been formed, of which we this day furnish a plan, and which already adds to the beauty and ornamentation of the Victoria Embankment. The design, which is Mr. McKenzie's, has been executed by Mr. Meeton, and we congratulate both on the manner in which they have severally carried out the work.

That work has been executed in accordance with the propositions contained in the following report made by Mr. McKenzie on January 27th of the present year:—

"I may state, at the outset, that I have avoided everything in the way of expensive gardening, and where a doubt exists as to the ultimate use of the reclaimed ground, I have endeavoured to submit a plan, which, if carried out will be effective at the present time, and capable of being cut up ultimately without a total disfigurement of the works proposed to be executed at this time. Of course, a much more expensive system of gardening might be introduced, without much alteration to the design, by the introduction of statues, fountains, and vases.

"The walks are so arranged as to give facility to the public from each of the recognised entrances, with a pleasant and diversified plantation on either side, at the same time preserving enough space for grass, which, in all cases ought to be well kept.

"The plantations, although nearly continuous, are sufficiently broken to give glimpses from the embankment roadway at such points as the breadth of the views will justify this being done.

"The nature of the plantations will be more expensive than that at either of the parks [Southwark and Finsbury] for two reasons. First, the nature of the surroundings, so far as the Metropolitan Board of Works is concerned, is so much richer than anything surrounding either of the parks, that a different class of trees and shrubs will be required to dress the ground. Secondly, the variety of trees and shrubs suitable is much reduced, owing to the growth of many varieties being destroyed by the influence of smoke and other causes inseparable from the position.

"The planting should be to a considerable extent of deciduous trees and shrubs; their beauty and brilliancy of foliage in spring will compensate to a great extent for the absence of foliage in winter, which is seldom bright, except after heavy rains. Thus, I should recommend the plantations to consist of groupings of Laburnums, Acacias, flowering Almonds, double-flowering Peaches, and other rosaceous trees; of double and single Thorns in groups of colours: also groups of trees conspicuous for their colour or variety of foliage, such as Copper Beech, Acer Negundo variegatum, &c., and filling up between with evergreens to give variety in winter, so as to afford interest to the plantations at all seasons of the year.

"Generally speaking, the plantations should consist of permanent plants, but I think it will be impossible to give general satisfaction without a few patches of flowers judiciously and sparingly dotted about.

"In dealing with the ground, I have endeavoured as far as possible to adapt the design to future requirements.

"In dealing with the Buckingham Gate, it will be necessary to lower the walk leading to it by throwing up banks on either side, owing to the gate itself being so much below the level. It would, however, very greatly improve the appearance if the gate were brought up to the level of the Buckingham Street roadway.

"In the formation of the ornamental grounds, I think it is of great importance that a water-pipe with hydrants be laid throughout the whole length, so as to be able to water when necessary, and wash and refresh the foliage, as so much depends on the beauty and health of the trees and shrubs in town on this being attended to, and so much depends on the future cost of the keeping, in having arrangements made suitable for the proper performance of these duties in the first instance.

"I should also recommend that all the walks be made of asphalt, so that they may be always clean and dry for use in all weathers. Although this will entail a large expenditure at first, I believe in the end it will be better, and nearly as cheap.

"From the magnificent way in which all the other works in connection with your board (Metropolitan Board of Works), have been carried out, it will be indispensable that the finishing of this portion of the work should be in keeping with what has already been done; for, in the words of the *Builder* of January 1st, 'we must go as far south as Naples to admire, in the magnificent coast roads that fringe that unrivalled bay, a waterside drive and promenade superior to that which London will possess when the Thames Embankment is completed.'

PORTRAIT OF MR. RIVERS.

We have to add the following to the lists of subscribers already given:—

	£	s.	d.
Anderson-Henry, I., Esq., Edinburgh	1	1	0
Anderson, T., Esq., 6, Marine Parade, Brighton	3	0	0
Binns, Richard, Esq., Ulverston	1	0	0
Lane, Messrs. H. & Sons, Berkhamstead	2	2	0
Spivey, Mr. E., Hallingbury Gardens, Bishop Stortford	1	1	0
Young, Mr. G., Audley End Gardens	0	5	0

WORK FOR THE WEEK.

KITCHEN GARDEN.

Now that winter is at hand, it is of importance to have a stock of keeping-roots in the vegetable-shed. Carrots, Parsnips, Turnips, Jerusalem Artichokes, Horseradish, Beet, Scorzonera, and Salsafy should be secured in the vegetable-shed, which ought to be several feet below the ground level, and have a close-fitting door. The above may be merely laid in heaps. If they are apt to shrivel, vegetables of this kind will be better in layers along with clean sand. Let all the *Cabbage* plants still

remaining in the seed beds be pricked-out forthwith. If there is any spare time get *Horsradish*, *Rhubarb*, and *Sea-kale* planted now instead of in the spring. In all cases be sure to trench deeply and loosen the bottom of the ground.

FRUIT GARDEN.

Let the Figs be protected immediately. Nothing is better and more simple than tying wisps of new straw successively along the stems, each overlapping the last. Let all superfluous nails be drawn from wall trees, and proceed at every opportunity with general pruning, the nailing, however, following the knife except on south walls. The trees on these had better remain until the end of January, as the buds are apt to become unseasonably excited.

FLOWER GARDEN.

Little can now be added here at present. Where lawns have not been well attended to through pressure of business, another mowing and rolling may take place. The bulk of the dead leaves should be removed immediately preparatory to a general cleaning. If the shrubs require a compost, it is a much more cleanly plan to bring back some decayed vegetable matter when a digging occurs. After so fine an autumn, during which period all bulbs have been got well into the ground, and the Tulip grower especially has commenced his labours under favourable auspices, it is advisable that every bed, however small, be properly and substantially hooped over, so that by covering with a number of Russian mats sewn together the whole length and breadth of the bed or beds, the collection may be safely defended from an excess of either rain or frost. Most amateurs were taught a severe lesson last season, the serious effects of which on their most choice bulbs will be for some time severely felt. Beds of choice Pansies ought also to be protected, and in mild weather traps should be set for snails, which even at this season of the year will cause great detriment to plants. Perhaps the best blooms of those beautiful spring flowers, the Polyanthus, can be grown in a pit, which may be built of turves from a pasture field, the roots planted in a compost of decayed leaves, loam, and sheep manure. I would advise your readers to try a turf-pit against one made with brick, at least those who are about commencing the cultivation of the Polyanthus; it will be found more secure from frost, and decidedly more congenial to the habits of the plants than growing them in pots in frames. Carnations, Picotees, and Auriculas must be kept clean and the pots not allowed to be soddened with wet; in fact, the less water the better compatible with health. The compost heap is a most important adjunct of good gardening, and in too many cases the management of it is still behind the improved practices of the present day. Such is not always the fault of the gardener, but frequently arises from an inadequate supply of labour at certain periods. I am not an advocate for complicated mixtures, still I must plead for a little loam and some other matters in the compost-yard. At this period one of the important points in this department is to see that the drenching autumn rains have every facility for escape. The best of soils, be they never so well harvested, will become soured in a very short period by the lodgment of stagnant water. A good compost-yard should on this account be a steadily inclined plane, and the soils or composts should invariably run the way of the descent in parallel ridges. Now, although the special mixing of soils a long time beforehand is by no means to be recommended, though dignified by the title of "compost," yet it so happens that in general gardening much surplus soil or vegetable matter comes to hand in the course of the year; such in all cases cannot and need not remain separate, for in the mixed state there will soon arise a demand for it, if only in renewing the beds of the flower garden. Those who have not harvested their loam should lose no time, for assuredly a little should be obtained annually if possible.

GREENHOUSE AND CONSERVATORY.

The winter-blooming *Correas*, *Epacris*, *Polygalas*, *Acacias*, *Pimeleas*, &c., will now begin to make a charming addition to the other inmates of the conservatory. Take care to give attention to judicious watering, more especially to such plants as the *Epacris*; it will not do to trust this process to inexperienced or neglectful workmen. Let all bulbs arising from their dormant state, such as the *Amaryllis* tribe, the *Lachenalia*, *Oxalises*, and others have very moderate supplies of water until the leaves are somewhat expanded. Keep down all decaying leaves, and observe the utmost cleanliness. If any of the stock appear too much crowded endeavour to weed out inferior or half-hardy things, transferring them to the pits or frames, or in case of severe need to a shed or outhouse, provided they

are of the hardy-leaved class, or decidedly deciduous. There is often occasion to employ fires at this period of the year, as much to promote an active ventilation and remove all superabundant moisture, as to make up for the deficiency of heat from external sources. However, assistance of this kind must be used with the utmost circumspection, and no actual interruption given to the system previously commenced of gradually reducing the temperature to correspond with the natural decline of the season, and consequent limitation of solar light and heat; considerable mischief cannot fail to ensue from an injudicious application of fire heat, particularly if used at night, and this should be held in view throughout the season.

STOVE.

Continue former directions in hardening growths, and endeavouring to promote a quiet somewhat dry atmosphere. Keep down all unnatural night heat. Hybrid Perpetual, Tea, and other Roses, as well as Chrysanthemums, if attended to, will render this structure, as well as the conservatory, most interesting for the next two months. Let these have weak manure water perfectly clear; it should be administered about 5° or 10° warmer than the atmosphere of the house. If given at every watering it is almost impossible to give it too weak or too clear; if the water is barely coloured it will be sufficient. An ounce of guano with a handful or two of soot will make a large bucketful or canful strong enough for anything.

FORCING PIT.

Now the leaves are falling fast it will be easy for those who have a pit at liberty to make it up for flower forcing. The leaves should have a portion of well-wrought dung mixed with them, if to spare; this will bring the leaves into perfect action immediately. About 9 inches of tan may be placed over the leaves in order to facilitate the plunging. Let the glass have a thorough cleaning. As soon as this is completed, flowers for forcing, if in proper condition, may be introduced immediately, such as the various Rhododendrons, Azaleas, Mosa or Provence Roses, Persian Lilacs, Sweet Briars, Camellias, &c., taking care at this period especially to introduce nothing unless it has gone through a proper course of culture during the summer, with the view of securing early-made and thoroughly ripened wood, for unless its condition is such it will be in vain to attempt early forcing. The Hyacinths and Narcissi potted in September may now be examined, and may be introduced successively in small quantities to the pit when their buds are 2 inches long. They should be plunged overhead at the front or darkest part of the pit, covering them 4 inches with old tan.

COLD PITS AND FRAMES.

These will now be extremely useful. Sawdust forms a good plunging material if new and dry, and coal ashes are also very good. Whatever material is employed, keep the plants within a foot of the glass unless perfectly dormant. Endeavour to keep the soil in the pot in a somewhat dry state.—W. KEANE.

DOINGS OF THE LAST WEEK.

KITCHEN GARDEN.

We took up the remainder of the Carrots, Beetroot, and Parsnips, and notwithstanding the dryness of the summer, we have never had better nor cleaner roots. We put a little more earth to some Celery, and would have used litter instead if we could have obtained it, but all protecting litter will be scarce this season.

Cauliflowers have a little disappointed us; the mild autumn, with the moist weather, brought it on very fine, but more quickly than we expected, so that we have hardly any worth raising in hails to plant in earth pits to be protected as we generally do. For this purpose the heads must be small, so as to grow. We have, therefore, put a good quantity in a shed, where it can be protected and will last a considerable time, though not so long as it would have done if we could have had smaller heads with good balls under glass, although the sashes were old and somewhat rickety. Fine heads of Cauliflower are easily injured. A few of ours were blackened by the frost on the mornings of the 10th and 12th, even though well protected by their own leaves, yet Geraniums in a raised border were but little injured. The very cold days at the end of the week have forced us to think of protecting and housing, or collecting in masses, to make protection easy. Were there only certain times in which certain things should be considered in season, much labour in protecting would be saved. Young Cauliflowers were saved from severe frost, and ere long we shall fill a frame with young

plants. We often find they do all the better when they grow but little all the winter, if they merely keep alive.

Kidney Beans.—We gathered about the last from an earth pit out of doors protected since the middle of October. These have done well, and clearing them out will enable us to fill the place with good plants of Lettuces and Endive, and very likely Strawberry plants in pots. Many Lettuces received a little protection where they stood, as when large the heart is easily injured. The Beans, Lettuces, &c., are a proof of what may be done late in autumn, with the help of a little protection, by *keeping the heat in the ground from freely radiating*. In this respect there is a great advantage to plants growing in the soil over other plants in similar circumstances growing in pots. To give the latter an equal chance, the pots should be plunged, and the surface mulched with dry litter. Even when rather tender plants are in pots and exposed, it is surprising what an amount of cold they will stand uninjured if the pots are laid down on the ground, and the pots and tops covered with mats or litter. This plan is the most effectual at the end of autumn and early in winter, as then the heat gained from the summer's sun has not quite radiated from the earth. Several times we have saved what otherwise would have been lost, by laying such plants down and piling snow over them when litter could not be had. The sides of exposed pots are good conductors, and soon cool the soil inside when freely exposed to the air. When sure there was not heat enough inside to cause elongation of growth, we have frequently allowed snow to lie on a cold pit for two or three weeks, as we knew it would require a very severe frost to get through it. We were laughed at once for getting a thin fall of snow swept up in a cold night, and lifted by ladder and thrown on the steep roof of a conservatory, when the boiler had given way just when its services were required. We do not recommend snow as a pleasant thing to work amongst, but it often proves one of the greatest boons to the gardener and the farmer. Many a time have we seen snow swept from pits, beds, vegetables, and plants, when it would have been true wisdom to have let well alone. We have scarcely a better non-conductor whilst it remains open and floozy.

A fine Radish bed in an earth pit we covered with some old sashes, &c., that the Radishes might be kept crisp, as those fully exposed and older, though looking well, are inclined to be hard from the cold.

Of Sea-kale and Rhubarb we took up some roots, and protected them with litter in case we should have a severe frost. We shall treat Asparagus in the same way. All these may be forced with propriety now when deemed desirable. All of them have this year ripened their buds earlier than usual. Globe Artichokes, that ripened so much earlier than usual, have now grown so green as to require more protection than if they had faded later and had grown less. Rhubarb and Sea-kale, more especially, will be the better of small mounds of ashes, burnt refuse, &c., placed over the buds as deterrents to snails, birds, and mice. The latter and rats have scooped out the buds for us where unprotected. After clearing away all litter leaves a slight sprinkling of salt between the rows will benefit the plants little, still it will keep many enemies at a distance so long as the earth remains the least saline. A few wide ridges may still be thrown up, on which to plant out young Lettuces in a fine day. If they keep alive they will feel the frost less than those succulent from growing freely.

FRUIT GARDEN.

Put the above plan in operation with our Strawberry pots, covering them slightly with litter on the afternoon of the 12th, as, even with a west wind, there were not wanting signs that we might have a severe frost. Very little protection will keep them all safe. Ere long we hope to place them under shelter. What a fine place a wide shed open to the south would be for all such purposes! There is hardly a place we know where the shed room is half enough, if the most is to be made of everything and labour economised. With Strawberry pots in beds, even out of doors, a little protection will often keep them all right, though if mice and vermin be excluded a cool place under glass is the best. We shall place a lot in frames where there is a little mild heat left, so as to bring them on gradually. They generally do best after the growth of the top has received a slight check, but with little or no check to the root action.

All fruit trees in pots not plunged or partly plunged, should be protected. Even in orchard houses the exposed parts of the pots should be protected with a little litter. When the trees are not large this is best done by setting them as closely as possible together, and then drawing the litter over and among them. By these means a large space can be cleared for winter

vegetables, salads, &c., that will require but little protection even in severe weather, when the house is dry, and the air inside still. When, however, the trees in pots are of considerable size, it is often prejudicial to lift them and pack them closely together, as thus the branches and bearing twigs are often bruised and broken. In their case, if the weather should be severe, a little litter should be put on and hang over the surface of each pot. A little artificial heat in severe weather would render all this unnecessary, but then it would not be an unheated glass case, and the inexperienced are very apt to use too much of this artificial heat in winter. In cold orchard houses such things as Parsley, Wallflowers for early blooming, early-flowering hardy annuals, &c., may be kept in a similar manner, and with but little trouble.

Chiefly to get the glass in better order, but partly to give the Figs a nipping, we have unroofed a low pit or Fig house, as after all our careful washing we still found traces of the dread mealy bug. This has enabled us to give rafters, &c., a coat of anticorrosion paint, which will shut up insects' eggs if there are any. A few degrees of frost will do the Figs no harm, and may settle all the bugs that are alive. We feel more interested, as until lately we had never been annoyed with this troublesome insect. In the hope of having a little frost first, we have forborne smearing the shoots as alluded to lately. We shall now have to look after the mealy bug everywhere, and see that he do not gain a hold. All purchasers of stove plants would act wisely by putting every new plant into a sort of hospital at first to prove it, especially as respects this insect—that is to say, if the general stock is clean. It is very unpleasant to be ever cleaning, as gardeners are obliged to be in many places, and then never be quite sure. But for the work in the Fig house, that, too, would have been filled with plants before now.

ORNAMENTAL DEPARTMENT.

For keeping a clean, smooth lawn nothing is better than a wooden roller, say 1 foot in diameter and 1 feet in length. If a little rough, it will, so far as worm heaps are concerned, dispense with all sweeping. The roller will merely be required to be scraped now and then to get rid of all the earthy matter. For small spaces, to keep down earth heaps there is nothing better than rolling, and then next day following with a good watering of clear lime water, which will thus go freely into the fresh-made holes, and kill the worms. For large lawns we must chiefly depend on the roller alone, as the watering is laborious when the lawn is large, and, besides, the worms are often good helpers to us as cultivators, even though their earth heaps give a little annoyance. By the sides of walks the heaps are often troublesome, and there lime water may be applied, as salt, though rather more effectual as respects deterring or killing the worms, would leave the part salted soft and retentive of moisture for the winter.

Considerable time has been taken up in getting the bedding plants saved in sheds, potted, and packed for the winter as previously stated. We were obliged to smoke some Cinerarias, which we rarely require to do, and we mention this all the more because the insects (green fly) came, we have no doubt, from breaking the rule so often recommended, of (after excluding frost), keeping the plants airy, cool, and moist. These plants had been placed rather close to a hot-water pipe in a pit, and as we were a little apprehensive, the pots stood on moss in a saucer. At one end of this pit there were Cucumbers, and so the pipe that went through was rather warm. The temperature where the Cinerarias were was modified by a little air left on, so as to neutralise the heat, but still the dryness was too much, and the smoking became necessary. Other plants standing cooler in another place, whence these insect-troubled ones were taken, that they might bloom sooner, were as healthy as need be. Many such circumstances open up the wide question—Whether we might not, by knowing better what plants rejoice in, keep away insects altogether, or whether we do not invite these to come by our treatment? It would appear that the juices of a healthy, luxuriant plant are less tempting to insects than the same juices when the plant is less healthy and vigorous. We have no doubt that extra heat will ever be attended with a number of insects.—R. F.

TRADE CATALOGUES RECEIVED.

P. Lawson & Son, Edinburgh, and 20, Budge Row, Cannon Street, London.—*Catalogue of Forest Trees and Shrubs.*

Stuart & Mein, Kelso.—*General Catalogue of Forest and Ornamental Trees and Shrubs, Fruit Trees, Roses, &c.*

James Dickson & Sons, Newton Nurseries, and 102, Eastgate Street, Chester.—*Catalogue of Forest Trees, Fruit Trees, and Ornamental Trees and Shrubs.*

TO CORRESPONDENTS.

* * * We request that no one will write privately to any of the correspondents of the "Journal of Horticulture, Cottage Gardener, and Country Gentleman." By doing so they are subjected to unjustifiable trouble and expense. All communications should therefore be addressed *solely* to *The Editors of the Journal of Horticulture, &c., 171, Fleet Street, London, E.C.*

N.B.—Many questions must remain unanswered until next week.

BOOKS.—A correspondent wishes for the names of books treating on Raisin, Currant, and Fig drying, and on South Australian gardening. (A. Y.).—"The Cottage Gardeners' Dictionary" will give you the information on all the subjects you name. It can be had at our office for 6s. 6d., or post free for 7s. 2d.

CROSSING WOOD.—A *Constant Reader* would be obliged if "UPWARDS AND ONWARDS" would state how and at what cost this process is effected.

LATE PEAS.—A correspondent writes that "Mr. Stephen Castle, of Prestwich, says in his letter in your last publication that to have Peas in October on this side Manchester must be very rare. Peas were gathered and eaten several times (the last time at the very end of the month), in October, at Polefield Hall, Prestwich, the residence of Mr. Howarth Ashton."

POPULARS (W. C.).—The rows of Poplars in the Regent's Park, and near Buckingham Palace, are the common Lombardy Poplar. They will be higher in time.

MASTIC L'HOMME LEFORT (W. C.).—Most of the London seedsmen who advertise in our columns could supply you.

SELECT CHRYSANTHEMUMS (H. E.).—*White*: Beverley and Mrs. George Rundle. *Rose-shades*: Prince Alfred, Christine, and Lady Harding. *Crimson and Purple*: Dr. Sharpe, Alma, and Prince Albert. *Yellow, Orange, and Brown*: Annie Sulter, Golden Beverley, Little Harry, and General Slade. The above are for specimens. *Pompons*.—*White, Golden, and Lilac* Cedo Nulli, *White* Trevanna, *Golden* Aurora, *Bob* (late), *Salomon, Durand, Andromeda, Florence, Prince Victor, and Sainte Thais*. *JAPANESE*.—The *Daimio, James Salter, Red Dragon, The Tycoon, Nagasaki Violet, Wizard, and Negro*; *Comet, Dr. Masters, Meteor, Jupiter, and Chromatella*. The last five are all shades of yellow and orange.

FLOOR OF GREENHOUSE (H. Y.).—We have no objection to the earth being the floor in your small greenhouseinery. There will be no danger of damp if you water carefully in winter. Concrete, or even gravel, and still more, tiles, would be neater; but earth is very well provided you have a pathway, and nothing is better than a narrow trellis of wood crossing in short pieces. Then when you clean the narrow trellis and rake the ground the bottom will always look neat with little trouble.

LAURELS DYING (R. O. F. S.).—We think the dryness may have something to do with your Laurels dying off one branch at a time. There are places, however, where the Laurel will not flourish many years, unless it is frequently cut down or shortened back. It is not quite so safe to cut in midwinter as early in autumn or the middle or end of March; but if work is pressing in spring we would not hesitate to cut back now, say, if the plants are large, cutting them all down from 2½ to 4 feet from the ground. The whole plant must be so treated. If a few branches or limbs are cut and the others left, the plants will most likely die at the points, and then farther back. We have frequently renewed Laurels by thus cutting-back. The cut places should be smeared over; lightish paint is best.

CUCUMBERS SCABBED (Jas. Ashby).—The rind of the fruit is affected by a dry gangrene, a result of the imperfect elaboration of the sap; but we are unable to tell whether it is caused by the roots absorbing some mineral in a soluble state that the leaves and fruit cannot appropriate, or is due to some influence of the atmosphere. All we know about it is that it is most common in limestone soil, or where the plants are supplied with water from limestone; but we have had it from using water from ironstone. It is a subject well worthy of investigation, and we should be obliged by our correspondents giving their experience.

LICHEN ON ARAUCARIA IMBRICATA (Forester).—From your description we think the green moss is a Lichen, which may be destroyed by scrubbing with a brush dipped in strong brine, so as to moisten every part of the bark affected. Equal portions of salt and water will not be too strong, but the solution must be applied to the parts where there are no green leaves, and there only. You may also dust the tree whilst wet with quicklime, which will destroy both the moss and the Lichen, but is more unsightly than brine, which leaves no trace of its application.

COVERING VINES WITH GLASS (H. Vernon).—We should prefer erecting against the wall the glass slating, or having a lean-to about 6 feet wide, and this will allow of space for a walk inside; and you could have Strawberries and Tomatoes on the front without injury to the Vines on the wall, only keep the Tomatoes low so as not to shade the Vines. At the top and bottom have a board 11 inches wide hung with hinges, which you can open or shut as needed. The moisture from the border will not be too much, and when the Grapes are ripening you can secure dryness by withholding water and giving on abundance of air. Upright sashes we do not approve of in your case, for they would be more costly and afford no greater advantages than a lean-to. Besides the Strawberries and Tomatoes you could have Vines on the roof at every 6 or 8 feet; or if you wished for Peaches and Nectarines, you might have two rows of double cordons respectively 1 and 2 feet 6 inches from the front, which in a 6 feet width of house would leave you half the width for the walk and the Vines. The glass frame ought not to be removed in the winter. It would be very useful in winter for growing salads.

VARIOUS (Centurion).—Beurre d'Arenberg would be improved by planting against a south wall, but a west aspect is best, though we have had it fine on a south wall. Cleveland Bigarreau and Werder's Early Black

Cherries succeed well on a south wall. *Rose Céline Forestier* would thrive well against the east side of your house if planted in good soil and watered well both at the root and overhead in dry weather. The varieties of *Gladiolus gandavensis* in heavy soils should be taken up now and be planted again from March to May, but so soon after the middle of March as the soil is in good condition. We know of no Apples that do well on a north wall. The *Morelle Cherry* does exceedingly well on that aspect, and so do *Currants*. We think 10 feet quite high enough for pyramid Pear trees, for when higher they are not only difficult to prune, but the fruit on the upper part is liable to be injured by wind. In exposed situations we consider bushes preferable to pyramids.

FUMES OF COKE AND CHARCOAL (*H. V.*).—They will injure all your plants, and probably destroy some.

WINTERING PLANTS IN A ROOM (*Saint George*).—We do not know of anything for keeping out frost that would serve you so well as the fire grate. You might safely have a fire all night by using a fire-guard. There is no apparatus that would suit the room and be available for a greenhouse. When you have the greenhouse we would have a small boiler, and two 4-inch hot-water pipes along the front and one end, with a stovehole outside.

GURNEY LILIES NOT FLOWERING (*A. F.*).—It is unusual for these to flower the second year, for the roots suffer considerably on being taken up. You did right to keep them growing last winter after flowering, but it was a mistake to keep them quite dry in the pots. You should have set them on pans filled with sand kept wet, even after the foliage was all gone, not, however, giving any water by the surface, but from the wet sand the pots would have derived some moisture. In August you shook out the bulbs and potted in fresh soil—that was a mistake; they ought not to have been repotted, but kept in the same pots until the bulbs had become so large as to burst them, and should have been kept on a shelf in the greenhouse constantly. We advise you to try them that way after this.

GESNERA SPLENDENS SHEDDING ITS FLOWER BUDS (*G. J. B.*).—It is apt to do so when the plants have been grown in a dry heat, and in a moister one the plants are excited into growth, and the buds drop, for the buds being formed in a drier atmosphere, they are incapable of the expansion consequent on the moist one. It is a common error to start these plants in spring and grow them all through the summer, and very often in vineries, where they are brought into a semi-ripened state just when they are forming their flowers, so that when they are placed in the stove for flowering, from the moist genial atmosphere, they start again for growth; the cause is, therefore, a check. We have known it caused by allowing the plants to become too dry, also from too much water, and from sudden changes of temperature. The only way to obviate it is to not start the plants too early. May is soon enough for winter flowering, and they should have a moist genial temperature, with abundance of light in all their stages.

POINSETTIA LOSING ITS LOWER LEAVES (*Idem*).—It is due to the wood ripening. The only way to keep on the lower leaves is to grow the plant in a good temperature, and not have any shoots but those made after June. Dwarf plants, and kept so by growing them near the glass, are less liable to lose their leaves than tall plants. The plant being deciduous, it is not possible to flower it without its losing a portion of its leaves, at least we have not seen it so flowered, except in the case of small plants.

CREeping PLANT FOR COVERING A BANK (*A Hampshire Highlander*).—We do not think you could have anything better than *Cotoneaster microphylla*; it is a neat, close-growing evergreen, producing pretty white flowers in summer, and bright red berries in autumn and winter. *Rægner's Ivy* would also answer well, having fine large leaves. *Vinca elegantissima* is also excellent. It has variegated foliage.

SELECT HERBACEOUS PHLOEXES (*B. B.*).—Comtesse de Chambord, Ange Gardien, L'Avenir, Madame Domage, Madame Barillet, Lierwali, Madame Froment, Madame Lemort, Madame La Marquise de Mironet, Madame La Comtesse de Malart, Monsieur De-lamere, Monsieur Domage, Monsieur Linden, Monsieur Marin Saison, Monsieur Veitch, Monsieur W. Bull, Queen Victoria, Roi des Rosos, Souvenir de Berryer, Vierge Marie, Annablis, Aurantiaca superba, Duc de Montebello, and Admiration.

ANEMONE-FLOWERED CHRYSANTHEMUMS (*Idem*).—Empress, Fleur de Marie, Haniel, King of Arcmones, Lady Margaret, Louis Bonamy, Marguerite d'Anjou, Marguerite de York, Miss Eyre, St. Margaret, Nancy de Sermet, and Mrs. Pethers. The training a standard *Chrysanthemum* requires is to remove all the shoots except one, or cut them away, and keep the plant to one stem until you have the height required, and then take out the point of the shoot. When it makes new shoots remove all but the three uppermost, and stop them when 6 inches long, tying down the shoots, but be careful not to break them. They should again be stopped, but not after the middle of July.

NAMES OF FRUITS (*Centurion*).—1, Much like *Passe Colmar*; 2, *Duchesse d'Angoulême*; 3, *Glou Morceau*; 4, *Consiller de la Cour*; 5, *Easter Beurre*; 6, *Belle de Noël*. (*E. Jones*).—We have no fruit from you, if with your own signature, or merely "J." attached.

POULTRY, BEE, AND PIGEON CHRONICLE.

AWARDS—TRIMMING.

WHATEVER shortcomings may fairly be urged against Mr. J. Wright, everyone will give him credit for his unvarying persistency; and though I have the well-known axiom before me as to "a man convinced against his will," I once more take up my pen in reply to his last letter. It is not difficult to reconcile his first and his second correspondence. On the 20th of October he wishes "an award of very highly commended should be given to all pens, and to those only, which in any ordinary show would be thought worthy of a place in the prize list," adding, "if, besides this, the pens highly commended were arranged in their order of merit, I think all that is necessary would be done," &c., &c.; and on November 10th he proceeds

to say, "that if I will read his remarks again I shall see that his chief suggestion was for a distinct award to be given to all pens, and to those only which in an ordinary competition, or by intrinsic merit, deserved a prize, and that this was the point on which he laid stress, and on which he wished to ask my opinion, and on this Mr. Hewitt says nothing." Evidently finding his ground as to the highly-commended pens untenable, he now leaves them out of the case altogether.

I should myself have been really much pleased if Mr. Wright had carried out his original intention, as stated on October 10th, of asking my opinion privately before mentioning it in these columns, as it would have avoided a vast amount of recapitulation and a rushing into print, contrary to my customary habits and desires. I, however, give every credit that Mr. Wright cannot possibly know the full amount of my poultry correspondence, for it is legion, and oftentimes when I have even written for twelve consecutive hours without scarcely a moment's intermission, and without desire of fee or reward—how frequently, I say, has the very next post delivery placed me in exactly the same fix in respect of poultry querists as that from which I had thus laboriously extricated myself; in fact, it is not long since our postman, when delivering my letters, said half playfully and half earnestly, "If the master's letters go on in this way I shall soon have to bring them to him in a wheelbarrow." Still, as Mr. Wright seems to have started a new transatlantic suggestion, I purpose to give the requested honest opinion as succinctly and plainly as I can do, so as to admit of no misconstruction. I cannot see much difference as to whether pens are very highly commended or simply highly commended, so long as he wishes them "arranged in their order of merit," for, if these words have a meaning at all, any practical judge will at once reply that this is not only awarding the customary three prizes, but also the additional very highly commended and the highly commended pens in "their order of merit"—a task infinitely more difficult and time-taking than the prizes themselves. If the intention of these avowed introductions is simply to give a sufficiently close idea of the state of the competition in the respective classes to would-be purchasers, surely this is as fully met by a glance at the number of pens highly commended. If they appear in numbers the competition is of necessity good, and if the prizes only are awarded, it is equally significant that the competition was at best scanty, or possibly that the prizes themselves were only reluctantly awarded by the judge to the best birds present. I repeat, from conviction, to carry out this new arrangement in the time is utterly impossible.

The American diploma Mr. Wright now substitutes for his former designation is simply placing the same facts under fresh colours. The honorary diploma card, which Mr. Wright suggests should in print state "that in an ordinary competition this pen would be worthy of a prize," will, I fear, meet with as little favour at the hands of committees as at my own, simply from the indisputable fact that poultry judges are already far too overtaxed, and cannot bear the additional feather that to a proverb destroys the powers of endurance of even the camel itself.

Not to recapitulate, I must give one other very cogent reason why increased labours in the same time are most unadvisable. If so many extra adjudications are to be made in the same time, the far more important awards for the customary prizes must of sheer necessity be proportionably hurried over and slighted, which, in my humble opinion, should never for an instant be entertained.

Mr. Wright then reverts to his old theory, "trimming," and states with "the results of his labours he is abundantly satisfied." If he is "abundantly satisfied," far be it from me to interfere with his self-complacency; but still on "trimming" he goes on to say, "Mr. Hewitt will, I think, admit there is some difference, however small, between the present time and two years ago." My admission is complete; some years back I dis-qualified, and by name published the full particulars of a very cobbling job by sticking in the tail feathers of a Bantam cock with cobbler's wax. In the present day we have, on the contrary, quite a scientific refinement on this very primitive mode of procedure: it is now the manipulation of an artist, the desired tail feathers are fixed to a nicety in the barrel of the natural quill with quick-drying varnish. The progress we have made seems to be this, as the eyes of amateurs generally are specially directed to the subject, the really exquisite workmanship of the trimmers of the present time is far more difficult to discover, and afterwards prove to conviction, than that of former days, but the intentions of those who prac-

tise these deceptions remain as unchanged as ever—viz., to obtain by fraud that which they cannot hope to accomplish by honest means.

Mr. Wright remarks, "that the worst, or one of the worst trimmers he ever knew is also a man who sells eggs that hardly ever hatch." I fancy I know several amateurs who were the victims of this individual, now happily removed from this and all other fancies. He used to sell as "eggs from his best hens" (which undoubtedly was true to the letter) eggs that, having been incubated some week or so, on inspection proved unfertilized. He sold them, gloried in his dead robbery, and gained money. In short, there are knaves in all classes of society, and, consequently, in the poultry world as among all orders; such are not poultry-fanciers, but money-getters only, and it behoves all persons to be on their own guard for their individual protection. Somewhat lately a gentleman, a stranger to myself, but who, I am informed, is a young man of very considerable means, wrote me a letter, requesting me to say whether a pen of poultry he had bought at a very long price was the first-prize pen I had before me at the — show, particularly requesting me to give him "my own candid opinion of the affair," for if, as some of his friends told him, "they were not the birds, this would be the third time he had been taken in in the same way, to his great vexation." The hamper being already dispatched, I was, as it were, compelled to see them, and to the best of my knowledge and belief I then saw them for the first time in my life. As to the requested "candid opinion of the affair," I suggested in my reply that I thought "his want of caution proved him to be plucky, but not wise." It may be urged, Why did I not conjointly prosecute? The birds were taken back and the money refunded, the seller saying "they were not the birds he now believed, but must have been exchanged in transit on the railway, and he was a great loser." Surely arbitrators have quite enough to contend with within the respective shows themselves, without being pulled into constant hot water, brought on from the want of care in confiding purchasers; and if buyers will, in direct opposition to the suggestions in my last letter, pursue the almost certain course to such difficulties, however much to be deplored, they must help themselves.

Mr. L. Wright is undoubtedly correct in his advice, "never to deal with a known trimmer;" but I must differ in opinion with that gentleman in his mode of making such an one "feel you despise him;" this cannot be attained simply by the appellations of a "reverend sinner," the "scum," &c. On minds so seared as those to whom I have just alluded, public or individual opinion goes for little; their ill-gotten gains are clutched as the result of their duplicity, and this one object attained, the expression of disgust of the victim and his friends is lost altogether, and is as ineffective where there is no moral shame to "make them feel," as would be a discharge of dust-shot levelled at the back of an alligator or a rhinoceros. Their only really vulnerable part is, in my opinion, a pecuniary one, and should I see the pen of birds alluded to again, that did win, a thorough exposure at my hands will certainly ensue, leading, I trust, to prosecution. I will not infer for a moment, as Mr. Wright appears to do, that every individual who trims is to be avoided as a man capable of even far more atrocious acts than simply trimming, and no one could regret more than I should any instance of disgrace to an exhibitor, "who is in the hands of his servant, and who knows little of his fowl himself;" but judges, of course, cannot adjudicate on the spot as to the actual aggressor, but simply on the act committed, whilst I myself really fear (and I hope not uncharitably) that in most cases of trimming, the proprietor and his man are both rowing in the same boat, pulling together, and have the self-same goal in view.

Mr. Wright asks for the publication of the name of the professor to whom, in my former letter, I alluded as caught with the cocks' combs (for there were two fowls), "sewn through and through to keep them upright;" adding he knew of one of the protestors who stained the Cochin cock's wings, but he thought it (unwittingly on my part), an injustice to refer to such an "enormity," adding "one is not some." I confess that Mr. Lewis Wright and myself differ very widely in our opinions as to the justice or even good taste of publishing an offender's name anew after he has already suffered disqualification for his crime, and consequent punishment. The birds were not disqualified by myself, but by one of the most shrewd, expert, and conscientious of our judges with whom I am acquainted. This gentleman called my attention to them particularly; at a show at which I was his colleague, held shortly

afterwards, he pointed out to me (in hand) the still unhealed punctures—for the judge himself took out the stitches at the former show—where the comb had been "sewn through and through to keep them upright." A catalogue was, after judging, produced, and, as I had been previously apprised, they belonged still to the party stated, and he was a protestor against trimming. Not for publication, as I think it uncalled-for to the offender to personally renew the charge so long time past, but to satisfy the Editors of the Journal, I enclose to them the name of the delinquent, and also that of the very reliable judge who at the time disqualified.

It being evident that Mr. Lewis Wright speaks rather from theory than from practical experience on the matter of judging poultry shows, and is, perhaps, scarcely aware of its present difficulties, irrespective of any further additional labours, I wish, therefore, to offer that gentleman a proposition that if accepted will, I think there is not any doubt, finally settle the question; and let me assure Mr. Wright that I am quite open to conviction, for if I find myself in error I hereby pledge myself to adopt his plans if they work well. We are now getting into the short days, and I have many shows at which I am engaged very shortly to officiate. Pray let me induce Mr. Wright to accept the adjudications in a single instance. I will use my best endeavour to cause some committee to acquiesce in the change. The entries shall not exceed five hundred pens, for if there are more I will cheerfully take all the excess on myself. We can arrange to begin, as promised us, by nine, and the rest of the daylight is before us; but I cannot, contrary to all precedent, promise him a bed of roses with his portion. Interruptions and distractions from the committee asking for advice, and from time to time the already completed awards for the printed catalogue, may possibly occur. But Mr. Wright shall have unrestricted liberty for the exercise to the full of all his shrewdness and practical sagacity, not only to evoke in the first instance the customary triple prizes from the original chaos of the various classes, but also unmolested he may introduce any of the American diplomas, very highly commended, highly commended ("in the order of merit"), commended, and anything further he pleases to do. When he has completed his duties, if he can still say, "I look back on the general results of my labours and am abundantly satisfied," I question whether it may not prove much after the fashion of the schoolboy when he sings—

"Multiplication is a vexation,
Division is as bad;
The rule of three does bother me,
And practice drives me mad."

—EDWARD HEWITT.

AT SOUTHAMPTON SHOW.

No. 2.

"Unto Southampton do we shift our scene."—(Shakespeare's *Henry V., Act 2.*)

TUESDAY one o'clock the Show is opened, and soon after I stand within Carlton Hall, a long building with semi-circular-headed windows on either side, and with an orchestra at the end opposite to the one at which I enter. The bareness of the walls is somewhat relieved by a portrait, bust-shaped, of some one or other of the English poets, being painted above each window, and an oil painting beneath, while the orchestra opposite me has an organ flanked by shrubs and flowers tastefully arranged. All this the eye takes in at once. On a closer look one sees a table facing one covered with the silver prizes, among which conspicuous by their beauty and value are the cups given by Mr. Merrick Hoare, M.P., and his wife. Happily for those who always win silver, there are not only cups but egg stands (how suitable!), candlesticks, a tea urn, a jewel box, spirit stands, the last intimating that the health of the Southampton Committee and the Judge were to be drunk from their contents; and I saw among the prizes that very useful thing, a biscuit tin; indeed, cups were happily not in a majority. Let other committees think of this.

The poultry pens were arranged along the walls, and on each end; and there were two rows down the body of the Hall, where also were the dear little Canaries and their kindred Finches, while Macaws, Parrots, Pheasants, and the larger cage birds, were across the further end; while the Pigeons by an excellent and very effective arrangement, had the orchestra all to themselves.

I am half inclined to fancy that the worthy Committee, by the way in which they numbered the pens, had an eye to the health of all visitors, and especially of reporters, for the numbers dodged about sublimely, and I had to walk hither and

thither, doubtless to the great benefit of my liver, but also to my great bewilderment; so if you please, let the numbers another time run in the order of the pens as they stand in the Hall, and let me also say that pens with open wire backs must be given up. The birds naturally retire back, and doing so push their tails through the wires, as I saw, to the great injury of their plumage. Then, also, if they had whole backs, the central rows could be arranged back to back. With these two exceptions, the first troubling the visitors, the last injuring exhibitors, the Show was conveniently and very tastefully arranged, and Mr. Warren, the Secretary, was, like all his brother secretaries that I have ever come across, kind and courteous. I dislike and wish to discourage unkind criticism, that criticism with a selfish motive which is too often appearing, but a hint to improve it is well to drop. "Who are the critics?" says Mr. Disraeli, in "Lothair." "Those who have failed in science and art," is the answer. Who are the severe, fault-finding, judge-censuring critics in the poultry world? Those who have failed to obtain prizes.

The Spanish class was thin, but good. The first-prize pen contained a cock with a wrinkled face and a suspicion of blindness, the hen was almost tailless (this last remark I make for the special benefit of "SNDROSHIRE RECTOR," who likes matters relating to *de-tail*), but this pen beat, of course, the next prize pen, which contained nice birds but deficient in face. The *Dorkings* (age over one year), were most numerous, but Mr. Martin's rose-combed pen won easily, the moult was on many others. *Dorking* chickens were abundant and excellent, and "commendations" were rightly sown very thick. I handled the second-prize cock, and found him grand in shoulder and back, and very promising. *Cochins* were not numerous. Out of the seventeen pens about a third were Partridge, and one only White. The Dark *Brahmas* were so few that a binocular was needed to find them, while the Light were blazing in front in long rows. The *Game* classes were good, and many were grandly-built birds, the "little bits of things" not, happily, making their appearance. The *Hamburghs* were poor save the winning birds. The *Polish* pleased me much better, and the Judges too, as every pen but one was noticed. Great credit is due to the few tenacious and spirited admirers of these birds. Messrs. Boothby and Hinton have written well on them, and have also won with their pets, though missing the first prize, which was, indeed, most excellent. Then came the *French* classes, which must, indeed, be making way, as they were very numerous. It is easy to see that the silver prizes draw. "Bother the money, I don't want it" (lucky man that!), said an exhibitor, "I want a cup."

The "Any variety" class was not numerous—seven pens only, yet the birds were very nice, witness the Black *Hamburghs* and the prize *Malays*. By the way, "Y. B. A. Z.'s" two pens of *Malays* out of the whole seven, to say nothing of the *Malay* blood that stared at me in the great frames in the Game class. The *Game Bantams* were very numerous, but mostly too Bantam-like. Where were the long legs, the thin forms, the snake heads we want? But I went back again and again to admire the cock in the cup pen; he was, indeed, a Game bird. It was gratifying to see a revival in *Sebrights*, they numbered ten pens, far more than Birmingham could show a few years ago. Of *Ducks*, I must say some were "little ducks;" indeed, those called *Paradise* might have been petted by Eve herself. *Geese* and *Turkeys* apparently stayed at home all but a few.

The "Selling class," that class useful in enlarging the poultry fancy, was numerous, and the prices sensible; the *Pheasants* very beautiful, but very few. I must notice a pair of *African Cranes*, who craned their necks, apparently thinking, "Where in the world have we got to?" The dead poultry and eggs were not ornamental, but certainly in the interest of utility, and should, therefore, always appear at a poultry show.

Mounting the platform-like orchestra I find the *Pigeons*, and here the numbers were so puzzlingly placed that I had to play a game of hide-and-seek to find them. Strange that so few *Pouters* were shown, when *Fantails* numbered so strongly. Is the grand old fancy bird not loved as formerly? As at Glasgow, Bines won, and, except one pen, all were good. Good, too, very good, were the *Tumblers*. Among the *Barbs* all the winners were Blacks. The *Jacobins*, first prize, were very rich in colour, and excellent. The *Fantails* were marked "a very excellent class." Among the *Owls* nothing could exceed the first-prize birds, they were fairy-like; the highly commended birds, white with blue tails, much pleased me. *Turbits* very good. *Carriers* few, and the few pens not full, but good in quality. Among the *Trumpeters* there were a grand pair of

Blacks for first prize. The *Dragoons* produced a novelty, for a pair of *Yellows* were first, beating *Blues*. The "Any distinct variety" class pleased me greatly, and the *Black Florantines*, together with the *Leghorn fowls* and *Paradise Ducks*, were the new things of the Show. Among the "Selling class" were some good birds, and not dear. In short, a better number of fancy *Pigeons*, more advantageously exhibited, it has seldom been my lot to see.

And now descending the orchestra, I go to inspect the *Canaries*, which, to say truth, drew my heart to Southampton. It seems to me that fowls endure a show, and in the evening get excited; that *Pigeons* dislike a show; but that those dear little bits of caged vanity *Canaries* delight in a show, quite revel and glory in it, and think it such an excellent opportunity for getting admiration. How they like the company; how, if healthy, they strut and hop and twitter; how they pop their heads through the hole in front, not by any means always to get water, but to get nearer to you, and to show off their little heads; how each tiny bit of feathered conceit seems to say, "Come now, am I not the very prettiest of all? Say so, there's a good chap." The *Clear Norwich* stood, as they always ought, being *par excellence* the *Canaries*, first and foremost, and more thorough *Jonques* (I prefer that term to *Yellows*), it was impossible to imagine, as may be inferred from eleven being noticed out of twenty. Oh! Why would the breeders make a poor country parson break the tenth commandment? *Clear Buff* (no, I won't have it); *Clear Mealy* followed, and such "intensifying the colour under the meal," as says our "W. A. B.," I never saw exceeded. *Mealy!* why, sir, they were, some of them *Jonques* frosted on the back. *Cleaver* cleft his competitor in twain, and secured second prize. *Marked and Variegated Jonque* and *Mealy* were also good. The *Any variety Norwich* were chiefly *Crested* birds, some of great beauty, the dark full crest in many being as good as possible. Then the *Belgians*, those to my poor untutored mind elongated bits of distortion; but, please, no challenge from your admirers, for I should claim "liberty of clergy." Kindred to *Belgians* clearly are *Scotch Dons*, a few of which appeared; they are *Belgians* sent to a posture-master, and taught to put down their shoulders. Then came the *Lizards*, and I felt What a pity it is that your great and singular beauty does not last more than one season. The first-prize bird was fairly good, and the *Silver-spangled* were also very excellent, all noticed but one. But, perhaps, the gems of gems were the *Goldfinch Mules*. I could not leave them. Think of all being so good as to be noticed. No wonder, when such a perfection of colour, markings, and shape, are possible of attainment that *Mule* breeders, in spite of a hundred disappointments, should still persevere. Here was a *Jonque*, pure in colour, with a *Goldfinch* glow on the head, and even wings. Then the *Mealy* first-prize was cream of the cream, a suitable description for so light a bird. Perhaps this bird was the best of all, and the fine *Goldfinch* beak in place of the shorter *Canary* beak gives a delicate point to the slender shape of *Goldfinch Mules*, and sets off their symmetry. "Any other variety" class produced some singular *Mules* as to breeding, and a first-prize *London Fancy*. I own I was perfectly fascinated by the Southampton *Canary Show*, which exceeded all even that I had heard of it.

The *British Birds* gave variety to the scene, though one pitted the *Larks*, and said to the *Nightingale*, "You bird of the night are indeed out of place here." Then the *Foreign Birds* gave colour to the scene. First-prize *Cockatoo* got off his prize ticket and trampled it under his foot—his estimate of honour! The *Macaes* and *Cardinals* gave a tropical glow to the Show; while *Whidah Finches*, old favourites of mine, whisked their long tails or moved slowly like *Court Ladies*.

Such was Southampton Show, something worth writing about; and why, I ask, should there not be cage birds at all covered shows? An ornithological exhibition must bring more visitors, and be in itself more beautiful than merely a poultry and Pigeon show. Embrace all varieties of birds, and you cater for all varieties of tastes. The man who loves a Game cock despises a *Canary*, but the lady who loves the latter thinks the former a horrible bird. Please them both; do another year at Bristol as is done at Southampton, and then *Clifton Ladies* will send their pets, and many more come into the Drill Hall.—WILTSHIRE RECTOR.

NON-PAYMENT OF PRIZES.

At the Great Horton Show held September 10th, a prize list of which appeared in your columns, we obtained second prize

in Class 13, and having repeatedly applied to the Secretary for the same without meeting with any response, we beg to ask you what steps we should take to obtain payment?—W. & C. BURNISTON.

[Let your solicitor give notice that if the prize is not paid proceedings will be taken in the County Court.—Eds.]

SOUTHAMPTON SHOW.

I PURCHASED a pen of prize poultry at the late Southampton Show, gave my name and address at the Secretary's office, and paid for it by cheque. I was assured that the birds would be sent to me by rail as soon as the exhibition closed. Five days elapsed, and after in vain sending every day, at considerable inconvenience, to the railway station, I wrote to Mr. Philip Warren, the Secretary, demanding the reason for the delay in sending them, but received no reply. I also wrote to my banker, requesting him not to honour my cheque, but found it had been presented and cashed three days previously. I then thought of writing to the exhibitor, and by return of post had a very kind answer, stating that he was not aware the birds had been claimed, as they were sent back to him, and it was fortunate I had written in time, for he was on the point of selling them to another person.

I would on no account charge the Secretary with dishonourable conduct, but I do most unhesitatingly accuse him of gross carelessness and neglect of duty. I am perfectly aware that the secretary of such exhibitions has a most arduous task to perform, and allowances must be made for accidents; but when a man undertakes a duty of the kind, he should feel his responsibilities to the public, and, instead of sending a clerk to the office, endeavour to be there himself.—J. D. HOYSTER, *The Parsonage, Bradenstoke, Chippenham, Wilts.*

P.S.—I have just received (November 12th) the enclosed note from Mr. Philip Warren. Nine days after the Show he has thought proper to reply to my letter.

AYR ORNITHOLOGICAL SOCIETY'S SHOW.

(From a Correspondent.)

THE ninth annual exhibition of this Society was held in the Assembly Rooms, Ayr, on the 12th inst. The Johnstone Show being unfortunately fixed for the same day, there were considerably fewer fancy Pigeons than in former years, but the young Pouter and Fantail classes were the only two which were deficient in quality. The former of these was a complete failure, there having been only three pens on view, none of which in former years would have been considered worthy of mention, the first prize being awarded to a pair of Meales of more than average length, but unmatched for colour and markings, and deficient in carriage, although the absence of blocks in the pens somewhat accounted for the lack of motion. The other two pens, Black and Red, were better in colour and markings, but much inferior in length of feather and form. The Pouters in the class for any age belonged to a much superior grade of birds, and although few in numbers (seven pairs), there were several first class pens. The first-prize Red cock, originally from the loft of Mr. John R. Adam, of Canning Park, is an old winner at this Show, and well deserved his place, although the hen, never his equal, was in bad feather. The second-prize pen (Black) consisted of well-matched fair birds, but I think they would have been better placed after the pen of Whites, which were placed third; but all the others mentioned were so good and level in quality, that I was not surprised to hear many fanciers of different opinions as to the places awarded.

The first-prize Carriers were a magnificent pair of Duns, which judges and the public alike at first sight challenged as both cocks, but they proved their sex, and were universally admitted to be deserving of their place. The second-prize birds in my estimation were much inferior to the very highly commended pen, and the third to several not placed at all.

The Short-faced Tumblers embraced six pens, all of superior quality; amongst them were several English celebrities, and I should have liked to have seen pen 19, a pen of magnificent Blue Beards (hitherto known as Mr. Frank Graham's, if I mistake not), placed higher than very highly commended, but the three prize pens were all splendid Almonds; the first two matched to a feather, and the third, containing an old cock of extraordinary merit in head, beak, and carriage, but too dark, and matched to a hen of comparatively little value. Altogether, however, this class was an honour to the exhibition.

The Barbs filled only four pens, and I rather think that the judges made a mistake in not placing the third first, and *vice versa*, as in everything except bright cere I thought them inferior to all the others exhibited, and, before the Show closed, the cere was considerably faded. I noticed that the very highly commended pen consisted of birds of 1870, and I should have liked to have seen them awarded a prize, as they were of rare quality.

The Fantails, as I have stated, were a sorry lot, for although a few

good birds were shown, there was not a pair of even average merit. The first-prize cock was a grand-tailed bird, but devoid of nerve, and the hen was in my estimation simply a weed. Had the hen in the very next pen belonging to the same exhibitor been shown with the first-prize cock, the pair might have been worthy of a first place, but amongst so many inferior birds the judges could not, perhaps, do better than they did.

The Jacobins, however, were the feature of the Exhibition, the whole class being magnificent in chain and hood, and I believe the judges must have decided the merits of the birds from the single point of size, if I except the second-prize Whites, which for Whites were really good. I think, however, that the first-prize Blacks should have given place to the third-prize Yellows, and the very highly commended Reds, both of the same owner, a very young lady, who is to be envied for her magnificent stud of little short-faced, heavy-hooded, and long-chained Jacks. The Trumpeters were no fewer than I expected in a place celebrated for this breed, and it is not too much to say that the first-prize Blacks cannot be equalled out of Ireland. The Turbits, as a whole, were good, the first-prize Reds and the second-prize Blues being first-rate. In Owls I never saw such close competition—so close, indeed, that fanciers wondered how the judges managed to draw a line, there being only one pen below exhibition merit. Nuns and Magpies were shown together. The former (all coarse except the first-prize pen), monopolised the prize cards; but the Magpies, I think, were far more deserving. The common Tumblers and Selling Class call for no remark, but the three pens placed in "the varieties," were all splendid specimens, and there were many others of great beauty and merit.

The *Canaries* (all of the Scotch Fancy) were admitted to be superior to any ever seen in Ayr, although the local exhibitors did not succeed in keeping many prizes at home. There was a good show of fancy Doves, and conspicuous upon the tablea was a beautiful pure white Robin, the property of Sir Peter Coates, one of the Patrons of the Society, or rather of Miss Coates, which attracted much notice.

Annexed is the prize list.

POUTERS.—*Young*.—1, A. C. Glass, Ayr. 2, D. Munn, Kilmarnock. 3, A. Crawford, Both. *Any age*.—1, J. Mair, Kilmarnock. 2, D. Munn. 3, G. B. Phillips, Ayr. *hc*, Miss E. M. Beveridge, Ayr. *c*, A. H. Imrie, Bourtree Park, Ayr.

CARRIERS.—1, A. Brown, Kilmarnock (Dun). 2, D. Munn (Black). 3, Miss E. M. Beveridge (Black). *hc*, R. Gibson, Kilmarnock. *hc*, J. Mair. *c*, A. C. Glass.

TUMBLERS (Short-faced).—1, T. Wilson, Gas Works, Stewarton (Almonds). 2, J. Mair (Almonds). 3, Miss E. M. Beveridge (Almonds). *hc* and *hc*, Miss Beveridge (Blue Beards and Azates).

BARBS.—1, J. G. Orr, Both (Red). 2, D. Young, Ayr (Black). 3, Miss E. M. Beveridge (Red). *hc*, G. B. Phillips (Black).

FANTAILS.—1, R. McM. Banks, Bromberry (White). 2, T. Wilson (White). 3, R. Gibson (White). *hc*, F. Graham, Birkenhead. *hc*, J. D. Birrell, St. Q. *c*, J. Galt, Kilmarnock.

JACOBS.—1 and 3, Miss E. M. Beveridge (Black and Yellow). 2, J. Galt (White). *hc*, Miss Beveridge (Red). *c*, D. Young (Red).

TRUMPETERS.—1, Miss E. M. Beveridge (Black). 2, D. Munn (White). 3, Miss Beveridge (Mottles). *hc*, J. G. Orr (Mottles). *hc*, G. B. Phillips (White). *c*, J. D. Birrell (White).

TURBIS.—1, Miss E. M. Beveridge (Red). 2, D. Munn (Blue). 3, Mrs. J. Mair, Babry (Silver). *hc*, D. Young (Red). *hc*, R. McM. Banks (Silver). *c*, W. McKinlay, Kilmarnock (Blue).

OWLS.—1, A. H. Imrie (Blue). 2, W. McKinlay (Blue). 3, J. Mair (Blue). *hc*, Miss E. M. Beveridge (Blue). *hc* and *c*, G. B. Phillips (Silver).

NUNS OR MAGPIES.—1, F. Graham (Black Nuns). 2 and *c*, W. McKinlay (Black Nuns and Magpies). 3, T. Imrie, Bourtree Park (Black Nuns). *hc*, G. B. Phillips (Yellow Magpies).

TUMBLERS (Common).—1, G. B. Phillips (Black Balds). 2, W. McKinlay (Blue Beard). 3, A. C. Glass (Yellow). *hc*, R. Kirkland (Black). *hc*, Miss E. M. Beveridge (Mottles). *c*, A. Crawford (Black).

ANY OTHER VARIETY.—1, T. Imrie (Archangel). 2, Miss E. M. Beveridge (Starlings). 3, F. Graham (Lahores). *hc*, J. McCreath, Forehill (Dragoons). *hc*, A. H. Imrie (Antwerps). *c*, G. B. Phillips (Austrian Pouters).

SELLING CLASS.—1 and 3, G. B. Phillips (Pouters and Carriers). 2, T. Imrie (Blue Pouters). *hc* and *c*, A. Crawford (Fantails and White Barbs). *hc*, R. McM. Banks (Priests).

CANARIES.

YELLOW.—*Cock*.—1, R. Hanston, Kilmarnock. 2, D. Dick, Kilmarnock. 3, J. Pattison, Elderslie. *Hen*.—1, J. Wilson, Both. 2, R. Crawford. 3, R. Crane, Dalmeington.

BLUE.—*Cock*.—1, J. Conn, Arnieck Lodge. 2, R. Crawford, Kilmarnock. 3, T. McVie, Kilwinning. *Hen*.—1, H. Davidson, Arnieck Lodge. 2, R. Houston, Kilmarnock. 3, R. Crawford.

PEARLS.—*Yellow*.—*Cock*.—1, H. Johnstone, Johnstone. 2, J. Glasgow, Both. 3, H. Calder, Ayr. *Hen*.—1, A. Crawford. 2, J. Sealuar, Kilmarnock. 3, H. Johnstone. *Buff*.—*Cock*.—1 and 3, A. Foreland, Galston. 2, J. Norris, Ardrossan. *Hen*.—1, A. Crawford. 2, E. Baxter, Both. 3, J. Norris.

GOLDEN-NECK.—*Yellow*.—1 and 2, G. Bryden, Ayr. 3, J. M. Nicol, Pottery, Old Cumnock. *Buff*.—1 and 2, H. Goudie. 3, J. M. Nicol.

PARROTS.—1, R. J. Newton. 2, A. Glass. *Shell*.—1, R. Smith, Ayr.

STOCKTON-ON-TEES ORNITHOLOGICAL SOCIETY'S SHOW.

THE second annual exhibition of Canaries, Moles, and British birds, was held in the Temperance Hall, Stockton, on the 12th inst., when birds of first-rate quality were brought together, but the number was somewhat smaller than last year.

The closest competition was in the Lizard classes, which were remarkably good, the same birds being exhibited as those sent to other shows in the district, although some of them have since changed owners. The Norwich classes were also very well represented. The Variegated Male prize bird was a splendid yellow. The British birds made up the most extensive class in the Show, and embraced a great variety of specimens, some of which, although they did not boast a card on the cage, were very much admired by visitors.

Subjoined are the awards.

BELGIAN.—*Clear Yellow*.—1, J. N. Harrison, Belper. 2, R. Robinson, Middles-

brough. *hc*, R. Corney, Stockton. *Clear Buff*.—1, J. Jackson, Stanhope. 2, R. Robinson. *hc*, J. N. Harrison.

NORWICH.—*Clear Jonque*.—1 and 2, Moore & Wynne, Northampton. *hc*, T. Irons, Darlington. *Clear Buff*.—1 and 2, Moore & Wynne. *hc*, R. Simpson, Whitby. *Evenly-marked Jonque*.—1, R. Hawman, Middlesbrough. 2, Moore & Wynne. *hc*, C. Greenwood, Scarborough. *Evenly-marked Buff*.—1 and 2, Moore & Wynne. *hc*, W. & C. Burniston, Middlesbrough. *Ticked or Unevenly-marked Buff*.—1 and 2, Moore & Wynne. *hc*, R. Hawman. *Crest*.—1, T. Irons. 2, R. Hawman. *hc*, Moore & Wynne.

COPY CREST.—1, Fairclough & Howe, Middlesbrough. 2, W. Cotton, Middlesbrough.

LIZARD.—*Golden-spangled*.—1, R. Hawman. 2, Stevens & Burton, Middlesbrough. *hc*, R. Ritchie, Darlington. *Silver-spangled*.—1 and *hc*, Stephens & Barton. 2, R. Ritchie.

CINNAMON.—*Jonque*.—1, Fryer & McClune, Stockton. 2 and *hc*, T. Irons. *Buff*.—1, T. Irons. 2, Moore & Wynne.

YORKSHIRE.—*Clear Yellow*.—1, J. Rowland, Skelton. 2, H. Ward, Skelton. *Clear Buff*.—1, W. W. Johnson, Northallerton. 2, J. Jackson, Stanhope. *hc*, H. Ward. *Variiegated Yellow*.—1 and 2, Stephens & Burton. *hc*, A. Webster, jun., Kirkstall, Leeds. *Variiegated Buff*.—1, R. Hawman. 2 and *hc*, Stephens & Burton.

CANARY.—*Clear Green*.—1, Stephens & Burton. 2, H. Jordison, Stockton. *hc*, Tenniswood & Brown, North Aclam, Middlesbrough. *Any other Variety*.—1, T. Craigis, Darlington. 2, Moore & Wynne. *Collection of Six, in variety*.—1, Stephens & Burton. 2, R. Layfield, Darlington. *hc*, T. Culvert.

GOLDFINCH.—*Variiegated*.—1, H. Ashton, Prestwich. 2, W. J. Stewart, Darlington. *hc*, W. & H. Winter, Guisborough. *Dark*.—1, Stephens & Burton. 2, W. & H. Winter. *hc*, M. Jackson.

GOLDFINCH.—1, J. N. Harrison. 2, Stephens & Burton. *hc*, Tenniswood and Brown.

LINNET (Brown, moulted).—1, W. & C. Barniston. 2, J. N. Harrison. *hc*, Fairclough & Howe.

BRITISH BIRD (Any other variety).—1, Fryer & McClune. 2, R. Corney, Stockton. *hc*, G. Deighton, Darlington.

SPECIAL CLASS (Brown Linnet Mule).—1, C. Robison, Gainford. 2, W. & C. Barniston. *hc*, R. Hall, Stockton.

JUDGE.—Mr. John Blenkinsop, Darlington.

HATFIELD ORNITHOLOGICAL SOCIETY'S SHOW.

"We had only seven classes last year. Arthur and I got it up. But you see we have done better this year." Verily, Hatfield is a fit illustration of the oft-repeated truism, "Unity is strength." At some places one sometimes finds a want of unanimity, and we hear of splits in the camp. All don't pull the same end of the rope. Such might take a lesson from the Hatfield "Happy Family." Only seven classes last year, but this year twenty-two, with an entry of more than two hundred birds! I think that is doing better; and better will be made better still another year, for a more enthusiastic, energetic set of workers it would be hard to find. "Arthur" is not Secretary, nor was my informant; indeed, it would be difficult to define the relative positions of the various members of the executive, all were so earnest and hearty. Mr. George Stones, the Honorary Secretary, it was evident, was the mainspring of the clock, but the timepiece seemed made of such a happy combination of material, that undue expansion or contraction of parts is next to an impossibility.

"Arthur" met me at the railway station with a dog-cart and fast-stepping horse—that is, when it began to step after the manner of horses generally, for its first performance was on its hind legs. I was afraid it might feel inclined to stand on its other legs, and a thick kicking-strap appeared to me very much like evidence that it would rather like the fun. However, after a few capers, backing, and filling, and trying to go astern, the three-year-old condescended to go on, and soon whisked us into the historical village of Hatfield; not so quickly but that "Arthur" had time to tell me with evident pride that as recently as May last the horse was unbroken, and no one but himself dared open the stable-door. And my life is not insured!

I was so much engaged all day that I had no time to explore the beauties of the place, and contenting myself with the information that a battle was fought in 688 (I won't answer for the date), at Hatfield Rings, that some of the armour dug up on the field of battle is in the grand old church of St. Lawrence; and that in the vestry of the same church there is a Peter's pen-box, of which there are only three in England. Contenting myself with this, I resolved to fall back on the county directory, which, unfortunately, tells me nothing. *Ex nihil, nihil fit* will apply. I did make a few pencil memoranda on the back of my catalogue, but they're all rubbed out, and I can't help it. I can just make out something about the end of Westfield House being covered with beautiful variegated ivy, and that's all.

The Show was held in the Boys' School, an old brick building bearing date 16-something, erected and endowed with a small annual income by some benevolent old gentleman of the period. The room was very tastefully decorated with festoons and wreaths of evergreens, interspersed with delicious autumn flowers, while several very cleverly executed scrolls with appropriate mottoes were traced on the broad whitewashed beams of the ceiling, from which, too, were suspended some vegetable marrows and pumpkins. It was evident that Hatfield meant to

do the thing properly. The whole village—village! it's more like a town, has a market, and is lighted with gas—was laid under contribution for wherewith to cover the walls; and the cases of stuffed animals and birds so obtained were in themselves a most interesting exhibition, and sufficient to stock a decent museum. From the collection I should infer that Hatfield is very prolific in weasels, stoats, polecats, and other scented Digitigrada; that they are found singly, in pairs, and in groups of six, and that they feed on every conceivable form of animal whose blood consists of red sealing-wax; that many varieties of Owls, Hawks, and other Accipitres are indigenous to the neighbourhood; while the Passerine, Scansores, Gallinaceæ, and Grallatorieæ have numerous representatives. Frosty weather, too, sometimes brings visitors from the Palmipedes, and a fat little specimen in a neat glass case was pointed out as having been won as a prize at a bird show at Doncaster. One bird puzzled me sorely. In shape it resembled nothing which ever issued from an egg. Such a Mule would make any man's fortune. A friend with whom I had much pleasant chat during the day, said it was a hen harrier, but I think it should go in the "Any variety" class.

I must not forget the pigs—pigs at a Canary Show? Yes. Why not? Outside of course. Proud the owners were of them, and well they might be, as they lay snugly ensconced in mountains of clean straw, themselves hillocks of fat. I thought them a very useful kind of bird to a cottager on 14s. a-week.

The Show proper was a great success. All the staging was draped à la Crystal Palace and Sunderland, and very pleasing was the general effect. From the prize list underneath the character of the birds will be easily gleaned. Mr. Young appeared for the first time this season, his hitherto matchless Buff Variiegated Goldfinch being much admired. No. 121 in the same class, bred and shown by Mr. W. Chesney, was a remarkably nice Jonque bird. It is of the heavily but evenly-marked class, grand in colour and in splendid condition, but not very large; a bird very bad to beat in anything but first-class company. There was quite a show of Goldfinches and Linnets, about fifty in all. The district abounds in them.

The Show was well attended throughout the day, in fact the room was crowded with ladies and gentlemen in the evening, and moving about was a difficulty. It closed at nine, and then began the packing for Stockton, and well it was done. "Arthur" had conveyances in attendance to run the Stockton lots to Doncaster, and he and I did the journey behind the three-year-old, who repeated his morning waltz with a few new steps. What a glorious drive! a good road, a good nag, a moonlight night, and a beautiful country. Left Doncaster 1.20 A.M., and reached home 6 A.M., half frozen.—W. A. BLAKSTON.

BELGIAN.—*Clear Yellow*.—1, J. N. Harrison, Belper. 2, Ross & White, Attercliffe. *hc*, W. Needler, Hall. *Clear Buff*.—1, W. Needler. 2, J. N. Harrison. *hc*, Ross & White. *hc*, Belk.

NORWICH.—*Clear Yellow*.—1 and 2, Moore & Wynne, Northampton. *hc*, T. Irons, Northampton. *Clear Buff*.—1 and 2, Moore & Wynne. *hc*, J. Thomas. *Evenly-marked Yellow or Buff*.—1, E. Mills, Sunderland (Yellow). 2, H. N. Fosbrooke. *hc*, Moore & Wynne. *Unevenly-marked Yellow or Buff*.—1 and 2, Moore & Wynne. *hc*, J. Thomas (Buff). *hc*, J. H. Clarke.

YORKSHIRE.—*Clear Yellow*.—1, E. Mills. 2, T. Fletcher, Sheffield. *hc*, W. Chesney, G. G. Lister. *Clear Buff*.—1, W. Hutton, Baildon, Leeds. 2, E. Mills. *hc*, O. Macdonald. *hc*, F. Higgins, Pontefract. *hc*, T. Green. *Marked*.—1, W. J. Stewart, Darlington. 2 and *hc*, L. Belk. *hc*, T. Fletcher. *hc*, F. Higgins. CINNAMON.—*Clear Jonque*.—1 and 2, T. Irons. *hc*, J. Spence, Sunderland. *hc*, A. J. Wells. *Clear Buff*.—1, T. Irons. 2 and *hc*, Moore & Wynne. *hc*, J. Young, Monkwearmouth.

LIZARD.—*Golden-spangled*.—1, J. Taylor, Middlesbrough. 2, J. N. Harrison. *hc*, E. Mills. *hc*, L. Belk. *Silver-spangled*.—1, J. N. Harrison. 2, L. Belk. *hc*, J. Taylor.

CRESTED OR TURNCROWN (Any variety).—1, J. Young (Crested Norwich). 2, W. Hutton (Copy Crested). *hc*, J. J. S. Clarke. *hc*, J. Thomas (Clear Crested); T. Johnson.

CANARY (Green or Grey).—1, Atkinson, Gateshead (Clear Green). 2, E. M. Shaw, The Parks.

GOLDFINCH.—1, J. N. Harrison. 2, G. Addy. 3, Miss Birdsall. *Light Mule*.—1, J. Young. 2, W. Chesney. *hc*, W. Needler; J. Stewart; W. & C. Burniston. Middlesbrough. *Dark Mule*.—1, Moore & Wynne. 2, J. Young. *hc*, W. Chesney; W. Hart, Darlington. W. Needler.

LINNET.—1, J. N. Harrison. 2, Miss A. Poskitt, Hatfield.

BRITISH BIRD (Any variety).—1, T. Gunnee, Hatfield (Chaffinch Rockingham). 2, T. E. Fosbrooke (Bullfinch).

FOREIGN BIRD (Any variety).—1, C. E. Fosbrooke (Diamond Sparrow). 2, A. J. Wells (Loobird).

LOCAL CLASS.—*Canary* (Any variety).—1, C. Gunnee, Hatfield. 2, A. Fosbrooke (Marked Norwich).

JUDGE.—Mr. W. A. Blakston, Sunderland.

NORTHAMPTON CANARY SHOW.

If ever a Canary Show merited the support of the fancy, surely that under the management of Mr. G. Moore at Northampton is, of all others, that show. I notice that the entries close on the 19th, that is on Saturday next, and Mr. Moore ought to receive such a bumper as is not often accorded to any Secretary. Moore and Wynne, the Siamese twins, a kind of double-yolk arrangement, are, I think, the greatest supporters of our Canary shows in England, while the town of North-

ampton generally contains more all-England exhibitors than any other place. No catalogue is complete without them, and seldom, indeed, does one appear without their names figuring prominently in the front, and dull would our stages appear unless lighted up by the wonderful birds they send out. I do hope that this short reminder may attract the attention of many an exhibiting committeeman, who has often been cheered by Moore and Wynne's bulky envelope on the eventful day of closing of entries; and that in east, west, north, and south, in every place which Northampton has for years generously patronised, it will be considered a fitting opportunity to pay a graceful compliment to the town by sending entries to *its* Show.—W. A. BLAKSTON.

"WAR ON THE BRAHMAS."

At a meeting of the North-western Poultry Association, held at Chicago some time since, there was a very lively discussion on the standard of excellence of Light Brahma fowls, whether they should possess a single or double comb. Many of the members of the Association expressed themselves dissatisfied with the standard of excellence of the Brahma fowl, now recognised by many breeders.

Daniel Worthington, President of the Association, presented various authorities, showing the original Brahmas to have been quite different, in style and shape, from the present standard; stating they were generally single-combed, the pea comb being the exception; that the form was more round and plump; shorter legs and bodies; not so gawky, and better layers; colour, slightly buff on the back, with a general mixture of grey.

After discussion *pro* and *con*, it was finally decided that as the present Light Brahma fowl was certainly a very superior bird, and the standard now in use was endorsed by all the prominent American and English breeders, the Association would not change the present standard, but rather adopt another for the Light Brahma, with *single* comb and markings in conformity to the authorities quoted by Mr. Worthington, thus enabling exhibitors to show both single and pea-combed fowls.

A late number of the *Prairie Farmer* remarks upon this subject (the war on the Brahmas), as follows:—"It is at last over, and there is peace in the hearts of the combatants. The question of double combs and single combs for Brahmas, is settled in a manner that ought to please both sides, whether it does or not. The decision virtually amounts to this:—That a Brahma fowl may possess either a single comb or a pea comb, according to the taste of the individual breeder; at least such is the decision of the North-western Poultry Association. The protracted discussion among its members has resulted in making two classes of Light Brahmae, and in establishing a standard of excellence for each."

This Society, in its proceedings, ignored the standard of excellence and description of this breed of fowls, as laid down by Tegetmeier, as being "incorrect and not adapted as a safe guide for the judging of" Light Brahma fowls. Whether the action of this Society in this particular will be adopted by others yet remains to be seen.—(*Moore's Rural New Yorker*)

THE YORK RABBIT SHOW.

MR. MILLINGTON takes me to task for commenting on the glowing account given by "CUNICULUS" of the attractive prize list for Rabbits at the approaching York Show, and declares the schedule to be "the very best ever issued by any committee in England." I have not the courage to deny such a positive statement; but as few things under heaven are absolutely perfect, I would ask, Where is the justice of charging the same entrance fee for the Variety classes as for the Lop-ears, and then awarding less prize money? This outrage on common fairness is the more apparent when it is remembered that Rabbits for the Variety classes must (I know not why) be in pairs, entailing more expense in carriage. If the York Committee think this just, I believe the fancy generally will wonder where they learnt logic. Surely the same proportion of entrance fee to prizes ought to be maintained in all classes of Rabbits, unless the Committee wish systematically to discourage the exhibitors in the Variety classes, who, however, cannot easily be dispensed with. The latter cannot see why they must send their specimens in pairs more than the Lop-ear fanciers; but Mr. Millington emphatically says, "I differ from your correspondent; I think they ought to be shown in pairs." but he does not vouchsafe one reason to show the reasonable-

ness of his dictum. Mr. Millington quotes the last Hull Show as proving my inconsistency in thinking a cup might have been given at York for the Varieties, when two cups are to be offered for Lop-ears. I would remind him that ours at Hull was a newly-started Show, and that the Committee had to tread their way very cautiously, which is not the case at York, where there is annually a large surplus. At all events, we did act justly and consistently in our money premiums, giving to Lop-ears £1 and 10s. prizes, entrance fee 2s. 6d.; and for varieties 15s. and 7s. 6d., entrance fee 1s. 6d. This proportioning of the fee to the premium is, I think, an arrangement that must commend itself to all lovers of fair play. It was not I, but another correspondent, animadverting on the injustice of the York schedule, who spoke of pairs being put into one pen, and often presenting disgusting scenes. I, who know how the arrangements are at York, cheerfully admit that in this respect the Show is a model for others; but nobody knows better than Mr. Millington that in nineteen cases out of twenty the Varieties are put in pairs into pens, and that no exhibitor can be certain what state his doe may be in when she comes home.—L. G. HUBSON.

EXPERIMENTS WITH PERMANGANATE OF POTASH AS A CURE FOR FOUL BROOD.

NOTWITHSTANDING the many investigations which have been made, and the different opinions which have been expressed, by men eminent in the apian world of science, the origin and cause of this fatal disease have hitherto baffled all attempts which have been made to discover them, while its cure remains equally shrouded in mystery. Like many other bee-masters, I have suffered very considerably from this plague, hence I am naturally anxious to find out a cure, and ever ready to make any experiments in which there is the smallest possible prospect of success.

A friend of mine received from an English apian a small quantity of the permanganate of potash, with instructions for using it as a cure for foul brood, but he having no diseased colonies sent it to me, and I happening at the time to have a colony affected with this dreadful malady, readily agreed to give it a trial. The following is the mode of proceeding:—The quantity sent (as much as would lie on the point of a table-knife), should be dissolved in a gill of water, of which solution a table-spoonful will be sufficient for each pint of syrup, to be given to the bees whilst in quarantine. As soon as they have all partaken of it, which they will readily do, mix a little essence of peppermint with some of it, and pour it on them in the skep in which they have clustered, so as to insure their being wetted with it, rolling them actually in it, and then they may be turned into a healthy stock or amongst healthy combs. He adds, "It is a simple remedy, but has effectually cured foul brood in two stocks of mine. As far as I can judge, it is only necessary to wet the bees inside and out and the cure is complete." He likewise says, "If the foul bees are driven from a straw skep, they will, of course, require more time than if simply brushed off the combs, as they will have filled their honey sacs with diseased honey; but I do not think they will require more than twenty-four hours, unless the swarm is large."

Having diluted this disinfectant as described, I took the required quantity, mixed it with a pint of syrup, and placed it upon the top of the hive (the bees having been previously transferred to an empty live), but they did not partake of it very willingly, for although I allowed it to remain for two days, they had not wholly consumed it. I now turned my attention to the second part of the prescription, took a quantity more of the solution, adding to it a small quantity of the essence of peppermint, turned the hive upside down, and poured it gently upon them. But, oh, what a calamity! the cure was worse than the disease, as in less time than it takes to write it, the little creatures had wholly forsaken the hive, with the exception of a few who were so wet as to be unable to fly. Never did a despotic monarch abdicate a throne, nor the inhabitants of a plague-stricken city flee, with greater haste than did this royal lady accompanied by her loyal and industrious subjects. I was so paralysed by this unexpected event that it took me some little time to comprehend it; but on recovering from my bewilderment I found my bees clustering on the landing-board of another hive, the inmates of which had set a strong guard lest these panic-stricken emigrants should attempt to find a lodgement in their midst. But where was my queen? After a considerable time spent in fruitless search, I found her lady-

ship with a few attendants on the branch of a currant bush close by. Having secured her, I placed her at the entrance of her home, expecting her to enter, but this she positively declined to do, and again fled; a second and a third time I tried her, but she as often refused, and it was only after I placed a clean hive on the stand that she consented to enter, taking along with her her loyal subjects.

This, then, is a brief account of my latest experiment with a foul-broody stock, and, like many more would-be cures, has entirely failed, as the colony still remains diseased; and as I know of nothing better, nor so effectual, I give my adhesion to the plan known as the purgatorial process.

Immediately on discovering that a colony is affected with foul brood, remove the bees from the infected hive to an empty one, allow them to remain there for a few days in order that they may thoroughly clean themselves, when they may be transferred to their permanent abode. This method I have tried with considerable success.—A STEWARTON APRIANIAN.

THE LONDON POULTRY SHOW.—We are very glad to learn that the entries for this Show have proved so numerous; they amount to nearly 1250 pens of poultry, and about 800 pens of Pigeons. Never before were so many Pigeons entered at one show. The Pouters alone muster 220 pens.

OUR LETTER BOX.

INACTIVE CROP (*Subscriber to the C. G.*).—Your fowls are suffering from stoppage between the crop and gizzard. You must discontinue feeding till you have opened the passage, then give small quantities of water as hot as can be drunk by the birds without injury. Follow up with doses of castor oil till the functions of the body are freely discharged. You must then feed on soft food, as sopped bread, for three days. (*C. J. S.*)—Your case is not an uncommon one. At this time of year the fowls pick up hard and dry grass that will not digest. It causes discomfort, which they try to relieve by drinking. There is a stoppage between the crop and the gizzard. There will be no cure till it is removed. We have given full instructions in a previous answer.

VULTURE-HOOKED BRAHMAS AND COCHRINS (*Mrs. C.*).—Vulture hooks should be eschewed in all breeding stock, as they amount to disqualification. The fault will sometimes appear in the progeny, but in fowls, as in everything else, the perfect birds form the exception, and to have many of them it is necessary to breed well, and kill well. By this process you will get rid of the vulture hook.

FROTH IN HEN'S THROAT (*Inquirer*).—Take the tail feather of a hen, strip it halfway down, pass it down the windpipe, turn it round quickly three or four times, and then withdraw it sharply. After this you may insert feathers dipped in turpentine four or five times per day. This will, we believe, remove the froth; and two pills of camphor, the size of a garden pen each, given for a few days at intervals of twelve hours, will cure. The two pills form one dose. If improvement justify it, diminish the dose half, and if the bird appear well, let well alone, and discontinue all treatment. We are not sure your fowls are not overfed and overfat. When such is the case, cease feeding and cause free action of the bowels. When the intestines become embedded in fat all the functions of the body cease to be performed in a healthy manner. On account of stoppage, that which should pass away returns, and aqueous matter would assume the nature of froth.

SPUR OUTSIDE LEG (*Houdan*).—It is a great disadvantage.

CRÈVE-CŒURS (*Jack*).—It is neither a disqualification nor a serious disadvantage for a Crève-Cœur pullet to lose a toe. If that is her only defect, we should exhibit her confidently. The combs and gills of the pullets depend much on age and condition. When they are about to begin laying, the comb and gills become enlarged and raddy. Some are more precocious than others, and develop these ornaments at an earlier age. It is not a disqualified pen if it consists of one pullet fully furnished and another guileless of comb and gills, but it is a disadvantage, and we should prefer to scud two without any, to sending two of apparently different ages. Large combs and gills are not essential to hens of this breed. The rough appearance about the legs is the "poultry elephantiasis." It is very troublesome, and is incurable in old birds. We have cured it in young ones by keeping the legs constantly lubricated with compound sulphur ointment. The disease came from abroad, and is very eccentric in its attacks. We have, as is duty bound, followed it and given it our best attention. We have never seen an adult cured.

FLOOR OF POULTRY HOUSE (*S. Wells*).—We do not like oyster shells for the bottom of a fowl house. We advise you to cover it thickly with road grit. That filters and is always dry. It is also an excellent dust bath, which is essential to fowls in confinement. Some mortar is very desirable, so is a plot of grass. Cinders are not good, nor is coarse gravel, in a limited space. If your fowls are forward show them, but not unless they are.

LAST YEAR'S HENS (*Hants Henwife*).—It would be a great pity to kill your adult poultry, as some of them will certainly lay as soon as they have moulted. You should now be getting eggs from your pullets. You need not be disappointed if you get but few, as this is the worst time of year, but you should have some. With pullets it is a question of age, not of season.

POWL'S LEGS SCALY (*B. B. A.*).—The only advice we can give you is to keep the fowl's legs always moist with compound sulphur ointment. It is a disease that first appeared a few years since, but has much increased of late.

ROUP IN PIGEONS (*Richard Hilton*).—The diseases of all birds are hard to cure, and no infallible Pigeon doctor has yet arisen. Prevent disease you may, cure disease you seldom can. Roup arises from cold currents of

damp air. A very able Pigeon fancier, who wrote in this Journal under the name of "FOREIGNER," says—"I have tried many remedies for roup, and I find that some Pigeons are recovered by one remedy, and some by another, and the majority recover. Some give a pinch or two of charcoal powder; some a dose of carbonate of soda, or a pinch of alum; or some a dose of flowers of sulphur." Warmth and hampseed we have known as remedies. Mr. Brent records he never had roup in his loft, neither have we, but ours is very warm.

POUTER MANAGEMENT (*Pouter*).—The house you have would do very well for these birds. Let them always have their entire liberty in it, except in very cold or wet weather, when we should advise their not being let out into the open wire aviary. Pigeons delight in sunshine, and Pouters like broad spaces of wood, like children's forms, to promenade on. Cold and wet bring trouble, but cleanliness and care will keep disease out as a rule.

TORTOISE (*Marian*).—If there is a heap of leaves in the garden it will bury itself in that heap; if not, bring it in-doors and place it in a cool cellar or cupboard, covered, but not wrapped up, by a piece of carpet. It will remain torpid until spring.

METEOROLOGICAL OBSERVATIONS

In the Suburbs of London for the week ending November 15th.

DATE.	BAROMETER.		THERMOMETER.				Wind.	Rain.
	Max.	Min.	Air.		Earth.			
			Max.	Min.	1 ft.	2 ft.		
Wed. 9	29.766	29.619	42	32	44	44	N.	.00
Thurs. 10	29.458	29.424	40	32	44	44	N.	.00
Fri. 11	29.482	29.470	40	21	44	44	N.	.00
Sat. 12	29.338	29.235	45	24	42	43	W.	.06
Sun. 13	29.363	29.259	48	26	43	43	W.	.00
Mon. 14	29.247	29.095	49	18	43	43	S.W.	.00
Tues. 15	29.122	29.070	39	20	42	43	N.W.	.00
Mean.	29.394	29.310	43.28	24.71	43.14	43.43	..	[0.06

- 9.—Dense fog; dense fog; densely overcast.
- 10.—Densely overcast; overcast and cold; cloudy.
- 11.—Cloudy and cold; overcast; densely overcast.
- 12.—Sharp frost; very fine; clear and frosty.
- 13.—Snow; overcast; very fine at night.
- 14.—Densely overcast; densely overcast; fine and frosty.
- 15.—Snow; densely overcast; clear and frosty.

COVENT GARDEN MARKET.—NOVEMBER 16.

Good samples of fruit are now in better request, the great bulk of it being inferior, and meeting with a slow demand at low prices. Common Apples and Pears change hands at from 2s. 6d. to 5s. per bushel. English vegetables comprise Brussels Sprouts, Savoy, Spinach, Coleworts, Broccoli, and Cauliflowers, and are better now than they have been for some time.

FRUIT.

	s.	d.	s.	d.	lb.	s.	d.	s.	d.
Apples.	1	0	2	0	Mulberries.	10	0	0	0
Apricots.	doz.	0	0	0	Nectarines.	doz.	0	0	0
Cherries.	lb.	0	0	0	Oranges.	per 100	6	0	10
Chestnuts.	bushel	6	0	14	Peaches.	doz.	0	0	0
Currants.	3 sieve	0	0	0	Pears, kitchen.	doz.	1	0	2
Black.	doz.	0	0	0	dessert.	doz.	1	0	3
Figs.	doz.	0	0	0	Pine Apples.	lb.	4	0	6
Filberts.	lb.	0	2	0	Plums.	per sieve	1	6	3
Cobs.	lb.	1	6	2	Quinces.	doz.	1	0	0
Gooseberries.	quart	0	0	0	Raspberries.	lb.	0	0	0
Grapes, Hothouse.	lb.	2	0	6	Strawberries.	lb.	0	0	0
Lemons.	per 100	8	0	14	Walnuts.	bushel	10	0	16
Melons.	each	1	0	4	do.	per 100	1	0	2

VEGETABLES.

	s.	d.	s.	d.	lb.	s.	d.	s.	d.
Artichokes.	doz.	0	0	0	Leeks.	bunch	4	0	0
Asparagus.	per 100	0	0	0	Lettuce.	doz.	0	9	1
Beans, Kidney.	per sieve.	0	0	0	Mushrooms.	pottle	1	0	2
Broad.	bushel	0	0	0	Mustard & Cress.	punnet	0	2	0
Beet, Red.	doz.	2	0	3	Onions.	bushel	4	0	6
Broccoli.	bundle	0	2	1	Pickling.	quart	4	0	6
Brussels Sprouts.	per sieve	3	0	4	Parley.	sieve	3	0	0
Cabbage.	doz.	1	0	2	Parasipis.	doz.	0	9	1
Capisious.	per 100	1	0	1	Pears.	quart	0	0	0
Carrots.	bunch	0	4	0	Potatoes.	bushel	2	0	4
Cauliflower.	doz.	2	0	6	Kidney.	do.	3	0	4
Celery.	bundle	1	6	2	Radishes.	doz. bunches	0	0	0
Coleworts.	doz. bunches	3	0	6	Rhubarb.	bundle	0	0	0
Cumcubers.	each	6	1	0	Savoy.	doz.	0	0	0
Turnip.	doz.	0	0	0	Sea-kale.	basket	3	0	0
Endive.	doz.	2	0	0	Shallots.	lb.	6	0	0
Fennel.	bunch	0	3	0	Spinach.	bushel	2	0	2
Garlic.	lb.	0	8	0	Tomatoes.	doz.	1	0	1
Herbs.	bunch	0	3	0	Turnips.	bunch	0	6	0
Horseradish.	bundle	3	0	6	Vegetable Marrows.	doz.	2	0	6

POULTRY MARKET.—NOVEMBER 16.

On making inquiry at market how trade was, we were told wretched, Game is having its effect on poultry, and it is difficult to sell either without submitting to a low price.

	s.	d.	s.	d.	lb.	s.	d.	s.	d.
Large Fowls.	2	6	0	8	Pigeons.	0	9	0	10
Smaller ditto.	2	0	2	6	Rabbits.	1	4	1	5
Chickens.	1	9	2	0	Wild ditto.	0	9	0	10
Hens.	1	9	2	0	Hares.	2	6	3	0
Geese.	0	0	7	0	Partridges.	1	9	0	0
Pheasants.	1	9	2	0	Grouse.	2	0	2	6

WEEKLY CALENDAR.

Day of Month.		Day of Week.		NOVEMBER 24—30, 1870.		Average Temperature near London.			Rain in last 43 years.	Sun Rises.		Sun Sets.		Moon Rises.		Moon Sets.		Moon's Age.	Clock after Sun.		Day of Year.
Day	Month	Day	Week	Day	Week	Day.	Night.	Mean.	Days.	m.	h.	m.	h.	m.	h.	m.	h.	Days.	m.	s.	Year.
24	TH					47.4	37.7	39.5	14	34	af 7	0	af 4	8	af 9	23	af 5	1	13	8	328
25	F					46.4	33.7	40.0	22	31	7	58	8	22	10	17	6	2	12	50	329
26	S					47.2	32.9	41.0	23	37	7	57	8	21	11	23	7	3	12	31	330
27	SUN					47.0	33.6	40.3	20	39	7	56	3	after.	35	8	4	4	12	11	331
28	M					48.1	33.9	41.0	22	40	7	55	3	44	0	48	9	5	11	51	332
29	TU					51.3	33.8	42.5	21	42	7	55	3	10	1	1	11	0	11	30	333
30	W					48.0	34.5	41.3	22	44	7	54	3	31	1	moorn.	7	7	11	8	334

From observations taken near London during the last forty-three years, the average day temperature of the week is 47.9°, and its night temperature 33.4°. The greatest heat was 62°, on the 25th, 1803; and the lowest cold 9°, on the 25th, 1-54. The greatest fall of rain was 1.21 inch.

THE POTATO AND ITS CULTURE.—No. 1.
THE SEED.



THE berry of the Potato is commonly called "the Potato apple or plum." When it begins to change from a green to quite a light colour it must be carefully watched, if seed from it is wished, and when it has the slightest tendency to burst it must be picked off, and laid on a dry shelf in a greenhouse; or, if there is not one, place it in any dry warm situation where the pulp will dry rapidly.

This operation requires great care, for if the apple is picked off the haulm before it has arrived at maturity it will rot, and render the seeds useless. On the other hand, if allowed to remain on the haulm too long the seeds will be shed, fall on the ground, and so in all probability the best will be lost. When the pulp has dried sufficiently, remove the seeds from the dry skin of the berry, and lay them on a board or slate, place a square of glass on them, and expose them to the sun to thoroughly dry them previously to putting them into the seed bag or bed.

On the treatment of the seed a great deal depends. If the seed has been gathered off a first-early Potato it may be sown to advantage the same season, but it will require the following treatment. A piece of ground should be selected on a warm south border, and after some good turf has been procured the operator may begin to build the walls according to the size required (of course this must be guided by the amount of seed in stock), but always keeping the front wall at least 1 foot lower than the back wall, so that when the coverings are put on the rain will run off. This done, the enclosure may be carefully cleaned and dug, and if the ground is in "good heart" it will not require manuring, but if not, I recommend the following compost:—Lime one-fourth, wood ashes one-fourth, well-decayed leaf mould one-half, all mixed together. Lime will prevent the approach of worms, which are great pests in the seed bed; wood ashes will improve the growth and the skin of the Potato; and leaf mould will serve as a nutritious manure. This manure should be scattered on the surface of the bed about 2 inches thick, and then dug in, but the quantity, as I have before stated, entirely depends upon the condition of the ground. The surface should be well pointed, and rendered fine with the spade. Drills, about 1 inch deep, may then be drawn, and in these the seed should be sown. If it is in good condition it may be sown very thinly. It is a good plan to sow only about three-fourths of the bed: for if the seed comes up well the plants may be thinned out to a reasonable distance, and transplanted on the remainder of the bed which is unsown. The drills should be about 16 inches apart, and as the young seedlings advance in growth they must be earthed up, although very slightly. The bed should be watered occasionally as the weather may render necessary.

If the autumn is cold and wet, the lights should be put on, or if lights cannot be had, make oblong frames the same length as the bed is wide from outside to outside of

the turf wall, and about 3 feet in breadth; these frames may be covered with canvas, prepared in the following manner:—Mix in a saucepan three pints of linseed oil and 1 oz. of sugar of lead with 4 ozs. of white rosin, place over a gentle fire till the whole is melted, keep it well stirred while it is on the fire, and when cold it will be of the same consistency as paint. It may then be laid on the canvas with a brush, the canvas being stretched on the frames and fastened with zinc tacks (which do not rust) previous to being dressed. The canvas will require one coat on the inside and two coats on the outside, and when dry it will be of a light yellow colour. This ranks next to glass for admitting light and heat. Where there is a cold frame, of course it does away with the foregoing method, but in either case air must be admitted at every opportunity in order to strengthen the young plants.

Seeds which are gathered from late varieties must remain in the seed bag till the following spring, as the seedlings never do well when raised entirely by artificial heat.

When the young seedlings have come to maturity, which may be seen by the haulm becoming yellow, they may be dug up, and their little tubers laid on a dry piece of ground exposed to the sun to become green and harden. When they have been sufficiently hardened and greened, they may be put in a bag and stored in a dry place safe from frost till the following spring. Each of these small tubers is "a set," and some growers say the qualities of the seedlings may be fully tested the same season as grown, but this I deny, knowing from experience that it requires another season to test them fully and accurately.

THE SET.

Next spring, on a warm south border under a wall or fence, dig out trenches about 14 inches wide, a good spade's depth, and about 18 inches from row to row, and lay the soil on the outside or right-hand side of the trench. By so doing the trenches may be placed closer together than if the soil were cast on both sides. This done, prepare an equal quantity of slacked lime, wood ashes, and well-decayed cow dung, the quantity to be applied to the ground entirely depending upon the richness and kind of soil; if very light, with a gravelly subsoil, little or no lime must be used. As this compost is put into the trenches let the soil be mixed with it, and plant the sets from 3 to 4 inches below the level of the surface, and about 9 inches from set to set; then cover the sets up to the level with the soil taken out of the trench. Before planting, every set, small or great, must have a piece cut off the end where there is a cluster of eyes; the reason for this will be found under the heading "General Remarks." If the weather be very dry a little water may be applied. If it should be frosty the soil must be drawn up to the seedlings, leaving just the head or crown exposed, and the following is a very good method of protecting them:—Procure some fir boughs about 3 feet long—the ends of boughs would be best, for they would be well feathered at the bottom—then arch the rows over with the branches, taking care to serve the ends of the rows the same as the sides to prevent

the wind from drawing up the rows. Advantage must be taken of every warm sunny day, and the covering should be taken away, which will enable the operator to flat-hoe and earth-up the rows if necessary, as well as harden and encourage the growth of the young plants. In all cases the covering should be put on while the sun is shining on the rows.

The time for planting entirely depends upon the locality. In the south and south-midland parts of England planting may be commenced in March, but in the north and north-midland counties planting must be deferred a fortnight or three weeks, but in either case the time must be left to the judgment of the operator.

As the tubers ripen, which will be seen by the haulm or tops becoming yellow, they may be forked up. Those which are ripe about the beginning of June may be termed "first earlies;" then those which ripen about July, "second earlies;" and those ripening subsequently are "late" varieties.

In examining the Potatoes, the large ones must not always be considered the best, nor the small ones the worst, but in both cases let a fair-sized, clear-skinned, shallow-eyed Potato be chosen, and let each root which is deemed worthy of being saved for culinary proof be kept separate from the rest, and let a private mark by which it may be identified be put on it. When the cooking is over, those which have a favourable report and prove first-rate in all points may be brought out as new varieties after a stock has been raised. It is a good plan to detail the characters and different qualities of every such variety, and whether it is a first early, second early, or late kind, for this prevents disappointment to the purchaser.—*J. C. Lewis, Gardener and Bailiff, Sudbury Rectory, Derby.*

CUTTING LAUREL BANKS AND HEDGES.

An inquiry was lately made about cutting Laurels, and the best time to plant them; and as in these matters many errors have at times been committed, some further details than those given in the reply may be entered into. Few plants bear the knife and saw better than the common Laurel, but it is advisable to point out when the pruning may be performed with the least amount of injury to the plant, as well as to the appearance of the shrubbery or group. There are but few shrubs so accommodating as the common Laurel in regard to the sites in which they are found to thrive; in a dry sand or a bed of the stiffest clay the plant equally continues in a healthy growing state, so it does in the black peat of a moorland waste, and in the decomposed chalk which overlies an immense depth of that material. In all these soils it remains, unlike many other plants, in a healthy state, and it will endure an amount of rude treatment under which others would succumb. At the same time it is certainly not the hardiest evergreen we have; on the contrary, some winters tell a tale on it in some places. From injury in these winters it sometimes takes years to recover, and sometimes it perishes entirely.

Planting Common Laurels.—So much depends on the character of the weather and other conditions, that it is difficult to say with certainty which is the best time to plant; for although I have planted Laurels—rather extensively too—in, I believe, every month of the year, the success and failure have been so confounding owing to circumstances, that it is no easy matter to say what time is best; but I may say that the time too often chosen for the work is about the worst, and that is the dry withering weather which often occurs in March. Better wait till May; the losses will then not be so great, as we then do not, as a rule, experience the parching east and north-east winds so prevalent in March. If showery weather occur in May, I would as readily plant in that month as in any. September is also a good time for the operation, and is better than later in the season, provided the ground is moist enough, or made so artificially. The long heavy dews, so common towards the end of that month, serve to moisten the foliage so well that the change is then less felt than, perhaps, at any other season, if in transplanting an abundance of good roots has been secured. But so accommodating is the Laurel that it is often planted in mid-winter, and, in fact, at all seasons, and in some districts it is a common saying that if planted upside down it will still grow. I recollect making many years ago a sort of fernery with the roots of trees and shrubs of various kinds, including those of Laurels, that had been grubbed-up. Many of them after having lain about a long time, grew where they were partly covered with earth; but it is not uncommon to witness large bushes taken up from a shrubbery where they had luxuriated for years, and used to stop a gap or hide an unsightly

object, turn rusty and die off soon after planting. Yet the plant does not always die when it puts on its red garb; a certain amount of life still lingers in it, and if treated patiently and left alone it would often recover in time, but the knife is too frequently called into play, and the plant dies further back than it would have done if left alone. Whenever the planting can be accomplished in September let it be done then, and the same may be said of April and May; but, if possible, avoid the dry north-east winds of early spring, as they do much harm to all newly-planted shrubs. It is, however, frequently necessary to plant at this time, and we must then be careful to secure to each plant as many roots as we can, and let them be well secured in the ground if that be at all dry and lumpy.

Cutting and Pruning.—Cutting, I consider, signifies a more extensive mutilation than pruning, as it now and then means the total cutting down of the plant. This I generally try to do in March, and sometimes as late as April; not that I advise doing the work so late, but as the shrubs operated upon are often in conspicuous places and seen every day, whatever may be the ultimate benefit, a severe cutting of evergreens disfigures them for a time, and the later it is performed the shorter time they are unsightly. With this object I seldom cut them till the middle of April, and then rarely cut them down entirely all at once, although the requirements of the plant may render this desirable; still whenever possible, a branch or two left on each plant will be of great service in securing an early and healthy growth, even if the branch left must be cut at a later period. As they act as nurses, their presence even if unsightly must be endured. I have on several occasions cut down large bushes (almost trees), of *Arbutus* which had become naked at the bottom, and by leaving a side branch or two a good bushy head was soon formed again by the growth which took place at the cut-down part, and Laurels are more prolific in buds than the *Arbutus*; but when the cutting down does not involve such severe amputations, the work can be done at another season if necessary. Much, however, must be left to the judgment of the operator, and I must content myself by saying it is rarely the plant is improved in appearance the moment it is cut; it is the better shape it is likely to assume when it has grown again that prompts the cutting, as the graceful character of the plant in its natural state cannot well be improved upon excepting when it is made to conform to a certain artificial arrangement. This brings me to another feature of the plant's utility, but before entering into it I will remark that those who have naked-bottomed overgrown Laurels that no longer fulfil the purpose they were intended for, which was to screen some unsightly object behind them, should cut them down at the proper time, and the young healthy after-growth will soon effect the object the older ones have, in fact, grown too old to do.

Pruning Laurel Hedges, Banks, &c.—Although I am not an advocate for much of this kind of work, it is, nevertheless, one of the features in many places which it would not be easy to improve; and as we have here, perhaps, as much cut Laurel to deal with as can be met with in most places, the experience of a number of years has enabled me to perform the operation in a more expeditious manner than was thought of at first, and the result is satisfactory. We have sloping banks and upright surfaces of Laurel to trim, as well as large breadths nearly flat. We have found out that to get the operation done in the quickest manner is better than taking more pains and letting the job linger for some time. Instead, therefore, of cutting over all the surface with the knife, we apply the shears, and so get over a large breadth in a short time; but it would not do to resort to clipping at all times, and I do not affirm it is better than the knife, but it is infinitely quicker, and it is important to get it all done in a short time. In our case we begin about the second week in July, and generally finish the same month, the whole being sometimes completed by the 25th. My object is as follows—Having an aversion to a closely-shaven surface, I have the Laurels cut over in time to insure a short growth afterwards of 3 or 4 inches or more, which growth hides all rawness caused by the cutting, and at the same time conceals the leaves that were cut in two by the shears. This cannot always be depended upon in many places, but with us it answers admirably, the second growth seldom exceeding the above length; and late in the autumn, when the growth is finished for the year, it is easy to go over with the knife and cut off very long pieces that stand above the general run of short leafy shoots which clothe the whole for the winter; and as these almost all ripen with us, the appearance is all that can be desired, as fully formed leaves terminate every shoot.

The whole thus presents the shape of the object it is meant to represent. The looking over in the autumn to cut away any irregular growth is really so very little, that the July clipping may be said to be all the Laurels get, and more is not required. A later period of cutting may suit certain places, but this one can find out after the first season, for if cut too early the after-growth is more than is required, and if too late there is not sufficient growth before winter, or what there is may not be ripened.

To those who have the time and inclination to cut Laurels with the knife, I may say that to do so nearly all the shoots below the eye ought to be severed in such a manner that their cut surface may be concealed, and not staring on in the face. A little practice will enable anyone to cut them so as to conceal all the cuts made, the cuts looking downwards instead of upwards. In this case no leaves need be cut through, but we have never had time to use the knife. Those who have but little Laurel-cutting to do, and have let the time pass for using the shears as described, and still wish to have a suitable second growth, had better adopt the knife-and-thumb practice. They will then with a little care make very good work.

I always treat Box edgings in the same way as the Laurel hanks—viz., cutting them so as to get a suitable second growth again to stand the winter; only in the case of the Box-edging I try to get the work done in showery weather if possible, as it becomes very brown if clipped in dry hot weather. The Laurels, however, from their more robust growth withstand the drought better.—J. RONSON.

GROUND LEVELLING AND PRACTICAL GARDEN PLOTTING.—No. 6.

DRAWING PLANS.

Fig. 24.—Form a square on the diagonal line *AB*, which is done by bisecting the lines as described in fig. 6. Make line *CD* equal to line *AB*, which can be done by taking the length of one side of the line *AB* from the centre, and dotting out the same length on each side of the centre of the line *CD*. Then draw the square *ADBC*. From the sides of the square form isosceles triangles *e, f, g, h*, which is done by drawing an arc in *e* with the radius *Ac*; also with the same radius from *c* draw an arc cutting the former one in *e*; and draw lines *Ac* and *Ce*, as shown by the dotted line. Find angles *f, g, h*, and *h* in the same way. Divide lines *Ac* and *Ce* into two equal parts; with radii *es, gr*, and *nm* draw the arcs as shown in the figure; also with radius *At* draw the arc as shown in *t*. Then draw the small portion of a straight line between arcs *r* and *t*. Draw the other parts of the figure in the same manner.

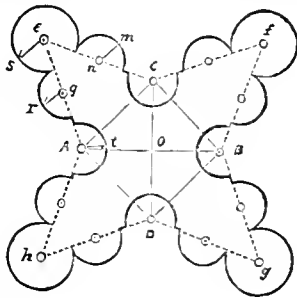

Fig. 24.

Fig. 25 is another application of the square and isosceles triangle. Draw the square and isosceles triangle as before described and shown in angle *A* *c* and *r*. Draw the diameter lines *EFGH*; from point *A*, with radius *AO*, draw arc *o* until it meets the sideline of the triangle, as shown where the line is cut. From point *m*, with radius *mn* draw arc *n*, uniting with arc *AO* where the line is cut, and touching diameter line *EFG* in *u*. The other parts of the figure are drawn in the same way when centre *m* is found, so that arc *n* unites with arc *o*, and touches the diameter line in *u*. All that is necessary is to draw a circle from the centre of the square, as shown by the dotted circular line, and cutting point *m*; find the distance from *u* to *m*, point out the same distance on the other side, as shown in point *g*;

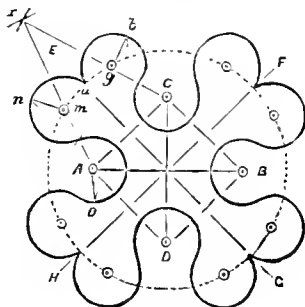

Fig. 25.

with radius *gb* draw arc *b*, which will unite with the arc drawn from *c*; and so on, until the figure is complete.

Fig. 26 is drawn from line *AB*. Draw line *An* any length; find the centre of the line, as point *c*; and on each side of *c* point off two equal parts, as *aa*. With radius *ab* draw arc *b*; with the same radius from point *c*, which is where arc *ab* cuts

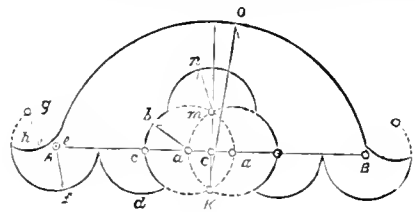

Fig. 26.

the base line *AB*, draw arc *d*; with the same radius from *e* draw arc *f*; with radius *gh* draw arc *h*. Where the arcs drawn from *aa* cut each other, as shown by the dotted lines, are the centres from which arcs *n* and *o* are drawn, as shown by the radii *ko* and *mn*.

Fig. 27 is drawn from rectangle *ABCD*. The rectangle is found in the following manner:—Draw line *DA* and erect perpendicular *AB*. With *D* as a centre and the radius *AB*, describe an arc. With *B* as a centre, and the radius *DA*, describe another arc, cutting the former one in *c*. Draw the lines *BC* and *CD*, and the rectangle will be complete. Divide line *AB* into two equal parts, also lines *BC*, *CD*, and *DA*. From point *c*, with radius *ef*, draw arc *f*; from *D*, with radius *DC*, draw arc *c*; from *g*, with radius *gh*, draw arc *h*; and so on with the other sides. Draw the straight lines as shown between arcs *c* and *f*.

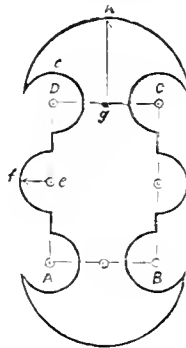

Fig. 27.

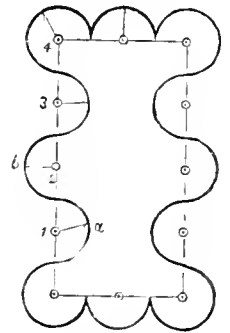

Fig. 28.

Fig. 28 is another application of the rectangle. The sides are divided into four equal parts, as 1 2 3 4, and the arcs drawn as shown by radii *1a* and *b2*.—M. O'DONNELL, Gardener to E. Lecming, Esq., Spring Grove, Richmond.

PEAS.

RECENT numbers of the Journal have given us some interesting matter on Peas. The subject of Peas seems ever welcome, and there is an old saw amongst gardeners, that to have plenty of Peas is never to be scarce of vegetables. If this is not all truth there is much of that virtue in it. Transpose the axiom and we see what cannot be denied, that to be scarce of Peas is to be terribly scarce of vegetables. Any information, then, which can ward off this ugly scarcity and insure a better supply and a better selection of this, the most esteemed of summer vegetables, is sure to command attention.

It may not be profitable, perhaps, to discuss the identity of Ringleader and First Crop Peas. The fact of both the eminent firms of Sutton and Carter having decided the question, one might think sufficient authority. The fact that other cultivators find a difference may reasonably be accounted for in their failing to secure pure stocks of seed. My experience is clearly in favour of the identity. I have grown them side by side, and, indeed, both kinds in the same row, the seed having been procured direct from the respective firms, and it was impossible to detect the slightest difference in any one point.

As to the heights of Peas, it would be as well if dealers would banish orthodox heights. First Crop and Laxton's Supreme

have both proved themselves ignorant of the statute of limitations. Three years ago I had the First Crop and Ringleader above noticed fully 3½ feet high. I know this is above the ordinary height. Peas, like other things, are affected by circumstances, hence it is as well to speak approximately.

It is generally admitted that this variety of Pea, whichever name it bears, is the earliest Pea known. It is also one of the most productive, and in some localities is all that can be desired as an early Pea. Another early Pea of the first order is Dickson's First and Best. In the particular soil I have to deal with, I find it the most satisfactory of all early Peas I have tried. It is not so early as Ringleader by three or four days, but for good pods and plenty of them, and for robust growth and constitution, it is unsurpassed by any Pea of its season.

I do not propose to take in review a long list of varieties. It is easy to err in growing a multiplicity of kinds. A useful and reliable variety for general cropping I find in Princess Royal. It is a good hardy sort and never fails to do its duty. Sown at the same time, or a day or two before the early ones, it comes in well in succession, and so does Champion of England, which is a few days earlier than Princess Royal and Veitch's Perfection, two Peas which have few superiors.

I grew Maclean's Premier last year for the first time. I am satisfied it is a Pea of sterling merit. It is very robust and stood the hot weather of last summer better, far better, than any Pea in the garden. It was sown at the same time as the others above mentioned, and proved the most really serviceable of any. It is a few days later than Veitch's Perfection.

Premier and Ne Plus Ultra are capable of doing all that is required of late Peas. For very late pickings, early ones sown in July are the best to be depended on. This year I let a few of the First and Best ripen on the haulm. I gathered and sowed them on the 13th of July. They have proved very useful. I gathered the last dish on November 7th.

The nature of my soil is very light, and the district is visited with a low rainfall; indeed, on an average, if it has not the lowest rainfall in England, there is only one exception. I have under these circumstances found it no child's play to keep up a regular supply of Peas during the past two seasons. Deep trenching alone would not have done it. Supplementary to deep trenching of the ground, I resorted to sowing in trenches, and leaving the Peas to grow as it were in miniature ditches, which once a-week were filled with water. By these trenches I could effectually irrigate the crop. I mixed a little salt in the water, sufficient to give it a distinct saline taste, and was rewarded with a fair supply of Peas, and not a vestige of mildew. After watering I gave the trenches a dusting over with dry soil to arrest evaporation. I had a few rows sown on the level and earthed-up, but found it absolutely impossible to get sufficient water to the roots, and they did little or no good.

I have reason to speak well of the furrow-system of growing Peas, and not Peas only—Beans, Carlinflowers, and almost all other crops were similarly treated, and the plan passed me through two very trying seasons in a far more comfortable manner than if I had not adopted it. My advice to those similarly circumstanced to myself is, Trench deeply, and sow and leave the rows in hollows, instead of sowing on the level and earthing up. I sow none on the level but the earliest crop.
—J. WRIGHT, *Gardener to Hon. J. L. Melville.*

GRAPES IN DALKEITH GARDENS.

On reading the report of Dalkeith Gardens by a correspondent in your number of October 27th, I observe that there is no mention made of the White Lady Downe's Grape. Having paid a visit to these gardens on October 28th, I saw this Grape in great perfection, growing side by side with its parent, the black Lady Downe's. I feel satisfied that when this fine Grape shall have become more generally known, it will be the favourite late white Grape. I can confirm all that your correspondent has said relative to Pines, seedling Grapes, &c. I noticed some of the latter showing immense sized bunches and berries. The Golden Champion is there growing strongly; it is a grand-looking Grape, and is of excellent flavour. I also saw some excellent bunches of the Alicante. I grow the Calabrian Baisin Grape noticed by your correspondent; it is a good late Grape.—ROBERT FLEMING, *Gardener to Richard Houghton, Esq., Sandheys, Liverpool.*

DECEIVED ROOKS AND VIOLETS.—Letters have been published lately speaking of rooks in various parts of the country re-

pairing their nests at this unusual period of the year. The Violets in the hedgerows in this neighbourhood seem also to have been misled and induced to believe that spring had arrived, as they are now in full bud, and if the weather should continue open, will be in flower in a fortnight, as they are already showing colour.—E. C., *Oakham.*

NOTES MADE DURING A TOUR IN IRELAND.

No. 3.

THE PHOENIX PARK, DUBLIN.

MAGNIFICENT, in truth! Wonderfully grand and expansive is Phoenix Park, Dublin! All Ireland is justly proud of it. In comparison with it our great London parks sink into insignificance in all the elements of natural beauty and grandeur; and, as regards extent, the Phoenix might engulf any two of them, and there would still be room to spare. The Phoenix Park forms the west-end of Dublin, on the north side of the muddy Liffey. It is here all the great officers of the state reside. Within the park various portions are enclosed—splendid domains indeed, for the residences of the Lord-Lieutenant, the Chief Secretary, the Under Secretary, and the Ranger, my friend Mr. Charles McDonald (all of which will be separately noticed), besides many other government establishments; also the police barracks, where some eight hundred young Irish police are trained, and the Hibernian Schools, where many hundreds of young Irish boys, the orphan sons of soldiers, &c., are educated and trained for soldiers again. This is a noble institution. There are churches, and schools, and teachers for the Catholic boys, as well as for the Protestants. On the Sunday, in company with Mr. McDonald, I attended the church of the latter, and was much pleased with the demeanour of the boys. What a boon it is for these poor boys to be educated and cared for thus, instead of being allowed to grow up in idleness, misery, and crime! After deducting all these enclosed policies, the extent of Phoenix Park is somewhat more than 1700 acres.

From the Dublin end to the other is a grand avenue, nearly three miles in length, and almost straight. About the centre, where several avenues intersect each other, is an imposing pillar with a figure representing the phoenix—that mythical bird. This was erected by the celebrated Lord Chesterfield, who laid out the principal parts of the park, and did so much generally for Ireland. The avenue is one of Decimus Burton's, and much more modern; it is nobly and well proportioned, marred greatly, however, in my opinion by the stiff and formal style of the planting of the trees in round groups, placed opposite each other. Many of the trees, too, are evidently ill-suited for their position, being chiefly American Limes, which, although they have been planted many years, are yet low and stunted. Limes are very much over-rated avenue trees; excepting in good moist soils and sheltered situations, they should never be planted. How immeasurably inferior to the Planes and Elms! Just alongside there are large, old, and magnificent specimens of the Dutch English Elm, forming part of the old avenue. How grandly they look, and how beautifully they have been planted in blocks of eight, forming an irregular yet continuous line, giving one an idea of immense extent. The planter of these trees was a true artist. The style of the planting of these trees completely puts into the shade the more modern attempt. With the exception of these splendid Elms, the trees of the park are in no way remarkable. Numerous attempts at planting groups and masses of trees here and there have been made, but in general with little success. The situations where trees are wanted are somewhat exposed, and the soil is dry and gravelly, so that it is a work of some difficulty to get the trees established. Several lamentable errors of judgment in the selection of the suitable varieties of trees in recent plantations were apparent; Ash, Larch, &c., being frequently planted on the dry gravelly banks, where such trees are as likely to grow as if they were planted roots uppermost. It would also be far better to plant smaller trees in such exposed places. Long spindly subjects planted in such situations never succeed. The natural tree of the park is the Hawthorn. There are thousands upon thousands of them, splendid trees too. In September they were covered with their red berries. How exquisitely sweet and charming they must be in their white dress of May and June; the whole air must be loaded with their perfume. Here, then, is the tree to plant in the exposed places; at all events, as nurses, until they become established, to others greater and finer. Much, however, may be

done with the many beautiful varieties of Thorns. There is ample room for Mr. McDonald to display his skill in planting, and earn himself a name in Ireland. I should advise him to take in hand our great London tree, the Occidental Plane, by far the finest, and noblest, and most suitable of all our park trees. I was told that the Planes had been tried and found wanting. I did not observe a single specimen anywhere in the park proper, yet in the Chief Secretary's grounds there is a large and fine example, proving that it will succeed if planted properly and cared for in its young state. Conifers might also be introduced in some of the dells and hollows to give variety. That they will succeed is proved by the numerous fine specimens round Mr. McDonald's own residence at Whitefield Lodge, which were the pet trees of the late Mr. Wilkie, for so many years chief ranger.

Of the general features of the park it is difficult to give any very correct idea. The extent, as already stated, is very great, affording excellent pasturage for numbers of deer and cattle. In the park, also, grand military reviews are held, and it is a noble place for them, there being open spaces of many acres where troops can manoeuvre to much advantage. On the southern side the ground undulates considerably, and here there are many naturally pretty spots with splendid views of the surrounding country, and the Wicklow hills in the distance. This is the place to roam and wander on sunny knolls and in shady dells—

"Beneath the milk-white Thorns
That scent the evening gale;"

yet, singularly enough, it is the least frequented. But then the Irish people do not walk or wander about; they all ride in their everlasting cars. This is a singular feature of the Irish character; they take all their exercise riding and driving, not walking. Near the principal entrance on the left-hand side stands a massive monument in granite to Ireland's greatest hero—Wellington; it is not by any means handsome, yet is attractive by its very ponderosity and hugeness, resembling, as the Irish critics say, "an overgrown milestone," and by no means a bad comparison.

Opposite to this monument on the right-hand side of the entrance lies the People's Garden, "a rare pretty place," as the carman told me, "with lots of flowers." "That was made in Lord Abercorn's time. He was a good man; he was the man for Ireland," he continued to observe, finding I was a stranger. This People's Garden is a small enclosed portion of some few acres, where a first attempt has been made to introduce the ornamentation of flowers, &c., as in our London parks. It is but an attempt, and as such it is scarcely fair to criticise it too severely. It would be scarcely possible, however, to conceive anything in worse taste. The situation is the top of a high ridge, and the principal features consist of several patches or mounds of loose stones with soil representing rocky mounds; on these many expensive plants have been placed, which of course soon die. These mounds have a very paltry appearance, and Mr. McDonald should lose no time in sweeping them away. In the hollow by the water close at hand something very pleasing might be effected with the stones referred to. A few flower beds are cut out here and there on the grass, but without any style or order, and these were planted with Pelargoniums, Calceolarias, &c., in an equally biggledy-piggledy fashion. I must except several magnificent beds of the dwarf Chrysanthemum-flowered Aster, which were the most effective beds of Asters I have ever seen; but the Aster is a plant not at all suited for such a prominent position, as it is so late in flowering, and lasts but a short time. There were one good group of the dwarf Dahlias, some good Gladioli, and a bed or two of Mrs. Pollock Pelargonium with *Centaura ragusina*; but of the general arrangement of the design as a whole the less said the better. I thought, if this is "rarely pretty" I am a poor judge, or the Irish people are easy to please. There is a grand opportunity for Mr. McDonald to remodel this, the People's Garden. What splendid scope there is, too, in the lower ground between it and the zoological gardens. A fine broad walk should here be formed straight through, and groups of Rhododendrons and other shrubs introduced. This part could be formed with great ease into one of the loveliest of spots, and at no great expense. A few of the trees, which are here pretty numerous, tall, and fine, would perhaps have to be removed, but that would be no loss, but the contrary.

Phoenix Park as a public park stands almost unrivalled, but it wants embellishments. More trees are required to afford shelter and enhance its beauty; and of the People's Garden, if it is to be worthy of the name of the park in which it is

placed, and of the good people of Dublin for whose pleasure it is maintained and was created, it must be greatly altered and extended. It rests with Mr. McDonald to suggest and plan for all this, and for a liberal government to enable him to do his duty to the good people of Dublin.—B.

BLANCHING CELERY.

THERE are many people who take vast pains to grow Celery, but beyond throwing a little earth up to it towards autumn the blanching for the most part has to take its chance. Preparing for table, or what I call putting on the finishing touch, is regarded too lightly, for there is no comparison between a well-blanching head of Celery and one that is not so. The former has a transparency which recommends it, for it looks well on the table; one may be tolerably sure it is tender and sweet; and its crispness shows plainly that the cultivator knows what he is growing it for. The latter is almost certain to prove more or less rank-tasted and tough, with only a small portion of the heart at all palatable, the remainder being only fit for soups or to be thrown away. I need hardly point out the waste of time and labour when the crop is in the condition I have just noticed, but I may remind those careless in such matters that there is probably no kitchen-garden crop more creditable than a thoroughly well-blanching lot of Celery.

In a deeply-trenched and well-worked soil earthing Celery is not much trouble, because there is no lack of fine earth to place round the plants; this should be pressed to them with one hand, while the other hand should be used to hold the plant upright and keep the leafstalks straight and close, so that no earth may penetrate to the heart of the plant. Afterwards the bulk of the earth may be added with a spade. In heavy stubborn soils the work of preparing the soil for earthing-up must be carried on regularly during the summer, and, if at earthing-up time it is not sufficiently broken up to apply next the plants, some soil must be prepared. I have used burnt earth and old potting soil with advantage, but it must only be very moderately moist, or finely sifted coal ashes are remarkably good substitutes; these will also keep the stems free being marked by worms, slugs, &c.

It is very rare to find Celery taken out of the earth so clean and free from the markings of wireworm, and the like as it is this autumn. I attribute this to the dry weather having either killed such pests, or sent them down into the earth, where there is more moisture, and from whence they have not yet returned.—THOS. REED, *Hatfield Park.*

THE BOVINIA POTATO.

MUCH has been written about that monstrous Potato, Pater-son's Bovinia. I procured 1 lb. last spring, which consisted of one large and one very small Potato. I carved these into bits with one eye to each, which were planted April 4th under by no means favourable circumstances, being, for lack of a better available site at the time, planted between two rows of Raspberries, the spreading roots of which must have drained the soil of much that might have gone to the support of the Potatoes. Nevertheless, on taking up and weighing the crop a few days ago I found the weight of Potatoes to be 84 lbs., some of the tubers weighing over 3 lbs. each. The largest Potatoes were the oddest and most wonderful-looking objects imaginable, the oddness of their appearance being greatly enhanced by their having supertuberculated to a considerable extent, the clusters of young Potatoes (some of which were of a large size) sticking about these monster tubers in all imaginable forms and shapes. I think it will prove essentially a cattle Potato, being so deep and many-eyed, and by no means handsome, though on trial the flavour was found to be very tolerable.—W. HURSON, *Chase Cliffe, Derby.*

WORMS IN POTS.

FLORISTS are very anxious to exclude worms from pots, but orchard-house cultivators seem to consider them as of no moment; yet one must suppose that they are as injurious to the roots of Strawberries and Pines as to other plants. Where pots stand on the bare earth it is impossible to keep out the worms, which foul the drainage, in addition to disturbing the roots; for this reason I always now set my pots on tiles. But worms or their eggs still get inside the pots in the compost, and I should be glad to banish them altogether; also the large yellow slug, which I often find among the crows. Now, lime

water is the remedy commonly recommended, but I observe that the Rev. J. Wood ("Garden Friends and Foes") says that lime is by no means so effectual as the carbonate of ammonia. He further urges the advantage of the ammonia as a manure. Of the efficiency of this remedy, if the solution be strong, I cannot doubt; but I should be glad to know from any of your readers who have actually made the experiment what is the extreme strength which the roots of ordinary plants, say the Strawberry, will bear. Would 2 ozs. to the gallon be excessive? I have tried carbonate of soda at this strength, but only to see its effects on worms. It did not seem better than lime water.—G. S.

FRUIT TREES FOR SMALL GARDENS.—No. 2.

As to the form of fruit trees for small gardens there can be no two opinions. Standards may be all very well for orchards, and where the cultivator does not set much value on his land, or has no eye to an early profitable return. If he care not for quality, and for planting for another generation, he will have an orchard. He may have fruit in seven years that will, perhaps, pay the rent of the ground, fruit that must be sold by measure, for it is not of a quality to have a value individually, and which if it is to be disposed of must be parted with at a cheap rate. It is not of orchards, however, that I wish to write at present; they are good in their place—for those who have ground to spare and can afford to wait—but I may state my conviction (undoubtedly a strange one for a gardener who has planted and is planting orchards), that orchards are not the most profitable and best means of growing fruit, quality as well as quantity being taken into consideration. It is all very well to look at an orchard in autumn when the trees are laden with fruit, but no one takes into account the time the trees were planted before any return was made, and it seldom occurs to many that the crop is always at the mercy of a gale of wind. There is much uncertainty from frosts destroying the blossoms, from the wind blowing off the fruit just when it is fit to gather; or if not, the danger of one branch laden with fruit rubbing against another causing much damaged fruit; besides, the trees are beyond easy control.

For gardens of whatever size, great or small, the peer's or the peasant's, there can be no question as to the form of trees. Standards, we know, usurp the whole of the ground in which they are planted, and render not only the ground over which their branches extend, but that for a distance beyond, wholly unfit for the successful cultivation of anything else. In a garden we expect something more than fruit trees, everything to stand on its own footing, everything to be good of its kind, everything to yield a good return for the ground devoted to it. I can recollect passing my first year as master gardener in a place where standard Apple, Pear, and Plum trees were at no very great distance apart, and my having to grow bush fruit (often under the standard tree) and vegetables in the spaces getting a gleam of sun. There could be no excuse for retaining them, as there was a capital orchard, and the walls were covered with good and useful trees. To ask the proprietor to clear out the standard trees would have been equivalent to asking him to cut down the fine old Oaks in the park. He had his old notions. It was folly to advise dwarfs or espaliers; the former would grow quite as big, it was only a question of time, and the espaliers would need to be so cut-in that they would not bear. He neither believed in root-pruning, nor in summer-pruning. Is not this applicable to our farm and cottage gardens? Are they not as a rule orchards, not gardens? Fruit there may be from the forest-like trees, but what of the quality and of the value of the ground for garden purposes? Large quantities of some kinds of fruit are in some establishments only useful in gratifying a class who care not whence a thing they like is obtained if they get it, or such fruit is left to decay in the fruit-room. In farm and cottage gardens this may not be the case. The fruit may be disposed of as the owners think profitably.

The objections I have to urge against standard trees in gardens, and especially small gardens are—1st, They take up too much room. 2nd, Their shade, the drip from them, and the roots, render the ground unfit for anything else. 3rd, Often a larger quantity of one kind of fruit is produced than is sufficient to meet all the demands required. 4th, There must be a want of variety which is always pleasing when good, as well as an inferior quality of produce in everything, for standard trees do not yield nearly so good fruit as espaliers, bushes, and pyramids. In these days quantity is of no use unless combined with quality. I might go further and say standards are

not profitable, or if they are, less so than pyramid and bush trees.

For gardens I am convinced of the inutility of standard trees, and in no case would I grow anything larger than a pyramid. I may be thought peculiar in my views, but I say that in this country pyramids of over 7 feet 6 inches, or, at the extreme, 8 feet, have their days numbered. Above that height they are too large for gardens and shade the ground, and they have a tendency to lean to one side, especially those on the Quince stock, and the fruit on the upper part is liable to get damaged by wind and the blossoms by frost if the situation is at all exposed. In an exposed situation I consider bushes preferable to pyramids, though there is no objection to pyramids of 7 to 8 feet high.

Pyramids and bushes of Pears, Plums, Apples, and Cherries are what I think most suitable for small gardens. Walks there must be in every garden; and on both sides of them I would have in all cases a row of pyramid or bush fruit trees in kitchen gardens, and even in the ornamental part of farmhouse gardens I would introduce them as specimens, whether on grass or in borders. On grass they would do well with a space of 4 feet round each kept clear of grass, and for applying top-dressings of rich compost so necessary for pyramid and bush fruit trees. A row of Pears, Apples, Plums, and Cherries on both sides of a main walk, planted at 9 feet apart, and standing in 4-foot circles at 6 feet from the walk, would have a fine effect—all blossom in spring, and laden with delicious fruit in summer and autumn. In a kitchen garden the trees need not be so far apart: 6 feet would be ample, but not too far. Nor would I stop there. In the place where the Box or other edging was I would have a galvanised wire (No. 6) strained exactly 1 foot from the ground; and if I had an edging at all it would be of tiles; equally distant from the trees on the other side I would have another wire strained. For training on those wires I would plant double cordon Apple or Pear trees 12 feet apart, so that each cordon would have 6 feet length of wire to occupy. The cordons might be either Apples or Pears according to the wishes of the occupier, but as Apples are the more useful fruit I would prefer them. By thus disposing the borders along the sides of the walks and planting with pyramid and bush fruit trees, there would be a sufficient supply for a family. It is presumed the garden beyond this is sufficiently large to afford space for a proper supply of vegetables. As a rule, the space devoted to fruit will be about one-third that of a vegetable and fruit garden combined.

Of course in gentlemen's gardens the walls must be taken into consideration, but taken altogether, the trees against walls, and those in borders and in the quarters occupy about one-third of the kitchen-garden ground. For farm and cottage gardens, however, I consider borders on both sides of the walks, or, it may be, one walk would afford a sufficient supply of fruit; but if not, and there were more ground than was wanted for vegetables, the part not required could be planted with bush and pyramid Apple, Pear, Plum, or Cherry trees at 6 feet apart every way to bear fruit either for family use or for sale, for it is only right that those occupying garden ground should make it profitable to themselves, what is not required being sold.

But who would advise planting bush and pyramid Apple, Pear, Plum, and Cherry trees as a paying speculation? Every one who has the scales of prejudice removed from his eyes, as he will have if he plant an equal extent of ground with standard trees, and with bushes and pyramids for comparison. It is usual to compare the produce of a few bush and pyramid trees but a few years old with those of standard orchard trees that occupy the whole of the ground devoted to the bushes and pyramids, and vegetables as well. Some have an idea that a small tree should bear as much as a giant, but take no account of the ground occupied in each case, nor do they consider the difference in the ages of the subjects. They expect a pyramid or bush tree, requiring at the most 4 square yards, to give as much fruit as a standard on from 36 to 64 square yards. Nothing is expected from a standard for the first two or three years; but a bush or pyramid is expected to do wonders the first year, and, if it do not, those whose advice prompted its planting suffer.

The only satisfactory way to come to a conclusion is to plant a piece of ground with standard trees, and an equal extent with bushes or pyramids, and note the annual produce of each. That is what I have done, and I advise others to do the same if they wish to become acquainted with the most profitable mode of growing fruit of superior quality. Let them prepare an acre of ground for bush and pyramid fruit trees. It ought

to be trenched; that will cost—say 1d per yard, or £10 1s. 8d., and the cost of the trees (1210) at 6 feet apart will be, for Apples, £99 15s., at 1s. 6d. each; also for Pears and Plums; but for a quantity like that they may be had for considerably less money. For properly planting, £3 will be required, for there is a great difference between planting and cramming a tree in the ground. The total expense will be £103 16s. 8d.—an outlay at first equal to the value of the ground, and for the first year we shall require manure for mulching, and for enriching the soil—say £5. The return the first year I will pass over, though the trees will do something. The ground being occupied with Potatoes will pay for the manure, and the cost of trenching will be returned as well as the labour of attending to the trees; but I will be moderate, and say the cost of the planting instead of the trenching will be repaid. This will bring the first cost down to £100, pay 5 per cent. on that for the outlay and rent, for both of which we require £10, £5 for manure, £5 for labour, or £20 from an acre of Potatoes. In trenched ground the Potato crop will do that and much more. The fruit, as said before is given in, though I have known the trees average half a dozen, which would give 7260 for an acre, or 100 pecks that would sell anywhere for £7 10s.

The second year we drop with Potatoes, they are excellent for keeping down weeds, and require "muck," the very thing wanted. They would pay the wear and tear, rent, interest of outlay, and leave the fruit for repaying the expenditure on the capital account, though we have paid the interest on it. Well, the second year they will average a dozen fruit each. I will put them down at 300 pecks at 1s. 6d., £22 10s., and our capital stands at £77 10s.

The third year we have the Potatoes for the last time, pay interest, rent, and labour, &c., as before, and will have a produce of fruit equal to a peck per tree. Where can we see trees at three years after planting giving a peck of fruit? I had such this year, and have the fruit now of Cox's Orange Pippin, for example, in Apples, and Marie Louise and Beurré Hardy among Pears, and I had Plums, also Cherries, at three years old, which, if not yielding a peck of fruit, have given as many pounds as there are quarts in a peck. This may be an exceptional year, but I have for the second time found what I have stated correct of trees at three years after planting. I will say 1210 pecks, at 1s. 6d., £90 15s., which will clear off the outstanding capital of £77 10s.

From three to seven years after planting the produce will rise from 1 to 2 pecks, many trees at seven years producing a bushel of fruit; but from three to seven years I will average the produce per tree at 1½ peck, or 1815 pecks per annum, which at 1s. 6d. will amount to £136 2s. 6d.; after paying all expenses this is cent. per cent. profit. At seven years they will bear 2 pecks each—2420 pecks at 1s. 6d., £181 10s.; the seven years' produce will be:—first year, 100 pecks, £7 10s.; second, 300 pecks, £22 10s.; third, 3210 pecks, £99 15s.; fourth, fifth, and sixth, 1815 pecks, £136 2s. 6d. each year, or collectively £108 7s. 6d.; and seventh, £181 10s. The whole value of the seven years stands at £710 12s. 6d.! Cent. per cent. on the outlay, and but a fraction short of 10 per cent. on the land, which is never calculated at more than 3 per cent. [We think our correspondent has made too little allowance for failures owing to season and other causes, and has placed too high a value on the produce.—EDS.]

The produce will increase from the 2 pecks at seven years to a bushel at ten years and often twice that, and, as far as I know, will endure a generation, for the short duration of Apples on the Paradise, and Pears on the Quince I believe to be purely imaginary.

Let us plant an acre of orchard, which at 21 feet apart will take about a hundred trees; these at 1s. 6d. each will be £7 10s., planting about £1, or £8 10s. in all. The first, second, and third years there will be grass, paying the rent perhaps; but as for fruit they will be few and far between. Nor is the produce in the fourth, fifth, or even sixth year much better; seven years must elapse before we can calculate on a peck, and that is quite as much as can safely be done, and then we have just the first cost of the trees. Another seven years will be needed to bring them level in produce with pyramids and bushes at three years, and another seven years will be required to get them into a condition to give as many pecks of fruit as are produced by the others at seven years. The produce of an acre of orchard trees is thought something extraordinary when it reaches 2000 pecks, representing a value of £150, which must not be looked for under twenty-one years, and that is less by 40 pecks than the pyramids and bushes will give at seven years.

There is one more point—the fruit from standard trees is not so fine as that of pyramids and bushes, and not produced with such certainty. It would be difficult to explain why this should be, but I find the nearer the ground any fruit is, there being no higher branches usurping all the vigour, the finer is the fruit. Cordons at 1 foot give finer fruit than espaliers at 4, 5, or 6 feet, and the fruit of pyramids is more uniformly large and good than that of standards.—G. ABBEY.

SALVIA VIOLACEA.

This annual is commonly known in our gardens under the name of Purple-topped Clay. Most lovers of a garden know the plant, yet how seldom do we see it grown, except in some out-of-the-way corner!

Treat it well, and bring it to the front of the borders and shrubberies, and it will be justly admired.

The culture of this *Salvia* is most simple. Sow the seed early in spring in any light garden soil, and transplant the seedlings, when they have made a few rough leaves, into the flower borders or fronts of the shrubberies. Everyone must admire the beautiful purple leaves on the tops of the flower shoots. It has also the great merit of lasting a very long time in perfection. The enclosed shoots are from the open borders, so you will see the plant, although a native of Mexico, is not at all a tender subject.—J. SMITH, *Exton Park, Rutland*.

THE PILLAR ROSE.

PERHAPS there is no form of the Rose more effective than the pillar Rose, and if this method of fashioning the Queen of Flowers was more thoroughly understood, Pillar Roses would probably be more plentiful in our gardens.

A pillar Rose when fully grown should be 8 feet high, broader at the base than at the summit, and in the blooming season it should be clothed with flowers over its entire height. The Hybrid Chinese and Hybrid Bourbon are the best kinds for the purpose, on account of the masses of large brilliant flowers which they produce. The Ayrshires, Sempervirens, and Bourbons stand next in order of merit, and these will attain the height of 10 feet or 12 feet if required; while the strong-growing Hybrid Perpetuals, Noisettes, and Bourbons, are available in positions where a maximum height of 6 feet suffices. The three latter groups, however, offer fine varieties that will form well-furnished pillars more than 6 feet high, and they bloom only by dribbles after the first flowering; still, where it is desired to have flowers in the autumn, rather than in the summer, they may be preferable, and they form by no means inelegant objects.

Pillar Roses may be planted singly on lawns, in groups, or in avenues, and in the latter case, if the walk is of grass the effect is materially heightened.

It is by no means difficult to form a pillar Rose; time and patience are the chief requisites. Choose from the nurseries the tallest and strongest plants, whether on their own roots or otherwise, and here, as elsewhere, be sure to obtain suitable sorts. This is a point of primary importance, and no amount of skill and patience will avail if it be neglected.

After the plants are fairly set in the ground, some recommend cutting back the shoots to one or two eyes, to induce the formation of a few strong shoots the first year. I have no grave objections to urge against this practice, and if the roots have been injured or curtailed in removal I recommend it; but under other circumstances my experience is in favour of leaving the plant unpruned the first year, or at the most restricting the operation of pruning to the removal of the weak, misplaced, and ill-ripened wood. Tie up the shoots to a neat stake immediately after transplanting, and the first growth springing from the top will further extend the height of the plant. This completed, the second or summer growth will probably arise from eyes nearer the base hitherto dormant; and while the former were weak and short, terminated with flowers, the latter will be vigorous wood-shoots, available for forming the plant, and giving flowers the next year. Pruning and training are the principal means by which we expect to carry forward our operations with success; but manuring must not be neglected. Be it remembered that a pillar Rose has more to support and develop than a dwarf or standard, and a liberal diet should be accorded to it. Manure twice annually in February and July; and if convenient, water frequently with weak liquid manure in the growing season, especially in dry weather.

But we have something to say on pruning and training. When

the plant has been a year or more in the ground (in the spring of the second year) pruning is absolutely necessary. Cut all weak, ill-placed, and crowded shoots, and shorten back such as are indifferently ripened to the first solid eye, taking care not to lower the height of the plant more than is necessary in carrying out these principles. The well-placed and well-ripened shoots should be pruned sparingly or moderately, in no case severely. After pruning, tie the branches round the stake with willow-twigs or tar-twine.

The operations of manuring, pruning, and tying, are to be repeated from year to year. About the third year the stake may be replaced by a small birch pole, with the snags left protruding some 6 inches from the sides, which have a pretty rustic appearance, and serve to protect the branches from the action of the wind. Thus is the pillar Rose formed, and few objects in the garden present a more gorgeous appearance.

When the pillar is five or six years old, now and then an original and main stem will show signs of debility. Such should be cut away close to the ground, and replaced by the young shoots which occasionally spring up at or near to the ground line. By this practice the plant is rejuvenated and retained in perfect keeping over an indefinite period.—WILLIAM PAUL, *Paul's Nurseries, Waltham Cross, N.*

USING FRUIT HOUSES AS PLANT HOUSES IN WINTER.

NOTWITHSTANDING the importance of the rule, "Have a place for everything, and keep everything in its place," there are few gardens, even the most extensive, where such a rule is not continually, and as a matter of course, broken. All sorts of summer and autumn fruiting houses are too much crammed with bedding and greenhouse plants in the winter months. Our earliest Peach house has now all its shelves filled, also every available space from wall to wall, except about 1 foot in width left as a pathway. We consider it better that before this thorough cramming with small plants, the Peach trees should have had a touch of frost, as they had this season, but frequently the trees have never felt frost, which is chiefly useful as helping to destroy insects, though we have little faith in even a severe frost doing much injury to the eggs of the insects which generally annoy us. We have some hope that the eggs of tropical insects may suffer, though, as lately stated, we have known instances where exposure to a keen frost did not destroy the mealy bug of our stoves. We may say the same of vineries; as soon as the fruit is cut and the houses cleaned, they are generally filled up with plants to be brought on for other places. These places being heated, very little heat applied keeps the plants safe, and saves a vast amount of labour if the plants must otherwise be kept in cold pits and frames during the winter, and a considerable amount of fuel if such plants must be kept in small houses or pits heated artificially. It is true, very large and lofty houses are rather difficult and costly to heat, but our common-sized vineries and Peach houses are much more easily managed as regards uniformity of artificial heat than smaller structures, and that from the greater amount of light, and the greater body of enclosed air being not so quickly heated nor so quickly cooled, and the plants thrive better. In a house with a lean-to roof—say at an angle of not more than 45°, even small plants will do far better in winter than in a rather flat-roofed pit. They will do well in a lean-to with rather a flat roof but with upright sashes in front; and they will do best of all in a span-roofed house with upright glass at the sides, provided just enough of heat can be given without making any part of the heating medium too warm.

There can be no doubt that many of us cram our glass houses far too much, and never allow a house to be empty summer nor winter. On the other hand, many who possess a nice little vinery or Peach house are so frightened to use it for anything else, that they keep it almost empty in winter, and give themselves endless trouble in keeping bedding and window plants, and even greenhouse plants, in cold pits, frames, empty rooms, &c., when all would have done so much better in the empty fruit houses during the most trying months of the year. They tell us they have too good reasons for their extra carefulness; for instance, one time their vinery was overspread with insects brought from the plants; at another time the plants themselves became too forward and weak before they could be moved; and at another time the heat given in winter caused the Vines and Peaches to break too soon and very irregularly, and thus they suffered during the season for the sake

of the plants even badly kept in winter. We can believe all this, and even much more. We know that a little over-firing and a little neglect in ventilating will bring on all these and kindred evils, even though such houses should be quite empty all the winter months. It is very easy to overdo or underdo anything, and thus the blame is often laid upon a system when the fault ought to be laid on the mode of working that system. For instance, a small fire will keep bedding plants safe in a large house; a large fire, as for Vines in February, will injure them. For those who want to make the most of their single vinery or Peach house in winter we would give the following rules:—

First, Use no plants that will not keep healthy and grow slowly in an artificial temperature of from 38° to 45°, with a rise of from 5° to 15° from sunshine.

Secondly, As a general principle do not thus fill a house until the crop is gathered, the wood ripened, the leaves fallen, and the house cleaned.

Thirdly, Do not keep such plants in a fruiting house long after you have raised the temperature for the benefit of the fruit trees—say a Peach house much above 45°, and a vinery above 50°. By, or before that time, the hardiest may be removed. Such plants as Geraniums may remain longer, if you can place them afterwards where they will experience no check.

Thus in a single vinery to which you give little heat until the buds swell and break of their own accord, you might keep your bedding plants from October to the end of March or the middle of April, and then place them under calico and mats out of doors. Camellias and Epacrises would bloom all the winter, Chinese Primulas, &c., and the Camellias would like the heat given to the Vines early in summer.

The last rule will apply to the welfare of the fruit trees, and they will not be unduly or irregularly excited into growth if the artificial heat in a Peach house be not raised above 40°, and in a vinery to more than 45°. Many plants may be kept safe and bloom at and under these temperatures, for with air early given, mere sun heat of from 10° to 15° more in a bright day will not unduly excite the trees. Whoever tries the matter carefully will find that such houses are more easily kept at a regular low healthy temperature than small pits even when heated. The very smallness renders more attention necessary, otherwise it is easy to have them freezing at one time and burning hot at another.

One great advantage of using fruiting houses for protecting purposes in the most severe months of winter is, that one can examine, pick over, surface-stir the plants, &c., in the worst or weather, when you could do nothing to plants wintered in pits. This advantage is so obvious that we advise all amateurs, when they resolve on having a pit all above or partly under the ground level, to have it wide enough to allow of a small pathway, so that all this necessary work can be done in rain, sun, or frost.

Some time ago we saw a small unheated orchard house standing empty, with good trees against the back wall, and six lights of frames outside, covered with lots of mats and litter in frosty weather. These frames, if made to take to pieces at the corners, would have stood in the little house—and what a saving there would have been in covering! whilst all the attendance and examination might have been given in the dry and comfortable house. A mat in severe weather would probably keep all secure, and more genial air could be given under such circumstances. A small iron stove in such a house would have kept all comfortable. For mild heat in small single houses nothing approaches the stove as respects economy of fuel.—R. F.

NIGHT SOIL AS MANURE.

I EMPLOYED, two years ago, as manure in my garden, night soil from an earth closet, and experienced exactly the same result from it as that complained of by Mr. Howard. The Cabbages, Cauliflowers, Carrots, Onions, Peas, and Beans treated with this manure were almost all destroyed by small white maggots at their roots. The earth as employed in the earth closets does not actually arrest or absorb the nitrogenous matter in the night soil, but only divides it very minutely; consequently when exposed to the effect of the sun and a moderate amount of moisture insect life is fostered, and the insects for their sustenance attack the roots of plants. To obviate this effect nothing is required but a more effectual means than dry earth to arrest the nitrogenous matter in the night soil. This I thought charcoal would afford. Having ready access to peat charcoal, I availed myself of it to treat the night soil with it

instead of with dry earth, and the result was all that I had anticipated. The crops were finer than I ever had them before, and no maggots, wireworms, nor slugs attacked them. I have employed night soil treated with charcoal the summer of this and of last year with perfect success, but with this difference, that the crops of the last summer, in spite of the dry season, were far more abundant than those of the preceding year.—CROMPTON.

THE STRAWBERRY ACTINIA.

The "Natural History of Redear" is an interesting little book, and certainly shows that that place abounds in every sort of marine life. It is a droll thing that our commonest Actinone (the Strawberry) is not to be found there. Mr. Ferguson mentions an attempt to acclimatise it, made by placing a couple of hundred *Fragarias* about among the rocks, but it did not seem to answer, for they all disappeared in a short time. I have noticed that this variety thrives best in rather fresher water than other kinds like, but that theory is at once knocked on the head when we look at a map and find Redear close to the mouth of a river.—KENNETH McKEAN.

[The mouth of the river is two miles away from the Sears on which the Actiniae are found.—Eds.]

PORTRAIT OF MR. RIVERS.

We have received the following testimony from a foreign admirer of Mr. Rivers:—"My gardening pursuits in fruit and orchard-house culture have always been guided by Mr. Rivers's instructions in his handbooks and periodical writings; so I have to thank him alone for success and the manifold pleasures derived from such gardening for many years. Perhaps these few lines from abroad will show that Mr. Rivers's great merits about popular fruit culture principally are appreciated not in his own country only."

The following additional subscriptions have been received:—

	£	s.	d.
Bass, A., Esq., Moat Bank, Burton-on-Trent ..	1	1	0
Bromfield, Rev. R. O., Sprouston, Kelso	1	1	0
Burnell, Mr. E., Chappel, near Halstead	0	10	0
Moody, Mr. H., Bury, Lancashire	0	10	6
Saltmarsh & Sou, Messrs., Chelmsford	1	1	0
Tweedale, Mr. W., Bury, Lancashire	0	10	6
Wesselhaeft, Mr. John, Hamburg	2	0	0

ENTOMOLOGICAL SOCIETY'S MEETING.

The first meeting of this Society for the present season was held at Burlington House on the 7th inst., the chair being occupied by Mr. H. W. Bates in the absence of the President. A very extensive series of donations to the Society's library from many American, continental, and English Societies of Natural History, and private donors, was announced, and thanks ordered to be given for them. Amongst these works were especially to be noticed a new general work upon the different orders of insects, beautifully illustrated by Mr. Packard, a rising American naturalist; a life of the late Thaddeus W. Harris, an American entomologist of great merit; and a memoir by Mr. Horne on the habits of a number of Indian Hymenopterous insects, illustrated with figures of their nests and transformations, with notes by Mr. F. Smith. A new part of the Society's Transactions was announced as ready for distribution.

Mr. MacLachlan exhibited a series of coloured drawings, representing the caterpillars of *Sphinx Galli* and *Ivornica* in all their states, executed by Mr. Buckler. Mr. F. Bond exhibited specimens of *Noagria brevilinea*; also a male *Caradrina cubicularis*, taken in company with a female *Senta Ulve*; also the small fly *Chlorops lineata*, found in the autumn in vast swarms on the ceilings of chambers at Cambridge, in which situation it is often elsewhere noticed, although no observation has hitherto been made as to the cause of its appearance there. Mr. Edward Saunders exhibited a gigantic Longicorn Beetle, *Xixanthrus Heros*, from the Feejee islands. Mr. F. Smith exhibited specimens of the rare *Meleoe rugosus*, found by him in some numbers at Prettlewell, near Southend, in the autumn, at the roots of grass. The males fight furiously even when at large, and two females which he had confined buried themselves in the earth of a flower pot, probably in order to deposit their eggs.

Mr. E. H. Vaughan exhibited various new or rare British Moths, including three new Phycids—*Trachonitis Pryrella*, *Homoeosoma Senecionis*, and *H. saxicola*. Mr. A. Muller exhibited some reniform gall spangles on the under side of Oak leaves, caused by *Cynips renum*, and some Pea-like galls in the same situation on Oak leaves, formed by *Cynips agana*.

The Secretary exhibited drawings and read notes on various insects—namely, *Anobium paniceum*, both larvæ and beetles, found feeding

on cayenne pepper—this insect had been confounded with *Lasioderma testaceum*, which had been found eating *Capsicum*—notes by Mr. Shoolbred on the silk cocoons of *Bombyx Peruyi*; notes and drawings by Mr. Holdsworth, of Shanghai, on various Lepidoptera and their transformations observed in China; and a note by the Rev. Mr. Warne on the black slimy larvæ of *Blennocampa Cerasi*. The following memoirs were also read:—On Butterflies from Basuto Land, by Mr. R. Trimen; conclusion of a memoir on the Longicorn Coleoptera of the Amazon Valley by Mr. Bates; on new Australian Curculionide, by Mr. Pascoe; and Notes on the Barytomine, by Mr. F. Walker.

INSECTS INJURIOUS TO THE PEAR TREE.

No. 6.

ANTHONOMUS POMORUM.

This little weevil has been named by entomologists *Curculio pomorum* and *Balaninus pomorum*. At this season of the year, and especially during frosty weather, the rough bark of Apple and Pear tree stems should be scraped off, for the purpose of destroying this insect. It shelters itself beneath the scurfy bark during the winter, awaiting the return of spring to renew its attacks upon the blossom-buds. "This insect" says Mr. Curtis, "commits great devastation in Apple and Pear orchards, by destroying the stamens, pistil, and receptacle of the flower. As soon as the blossom-buds swell the female beetle begins to deposit her eggs. In calm weather she selects a good bud, and makes a hole in it with her rostrum (long beak); she fixes herself at the hole, lays one egg, and goes on till she has deposited a considerable number of eggs in separate buds. The bud continues to swell, and the petals (flower leaves) nearly expand, when suddenly the growth ceases, and the petals wither and assume a shrivelled appearance. If one of these flower buds be examined when nearly expanded, a small white grub, with a black head, will be found in the centre, which begins to assume a yellowish colour; a few days later, the grub will be found either wholly or partially changed to a beetle—and should there be a small hole on the side of the receptacle, the beetle will have escaped; the transformation from the egg to the perfect state not having occupied more than a month. When this beetle or weevil leaves the receptacle, it feeds during the summer on the leaves of the trees, and is seldom to be seen. In the autumn the weevils leave the trees, and search for convenient hiding-places under stones about the trees or under the rough bark, in which they pass the winter. Consequently, as they commence their operations early in the spring, care should be taken to remove all stones, dead leaves, and other litter, from under the trees, as well as to scrape off the rough dead bark from them in the winter season." This beetle, or weevil, is scarcely one line and a half long; its wing-cases are dark brown, with whitish-grey stripes, its antennæ (horns or feelers) spring from the middle of its beak, and all these parts, as well as its eyes and the under part of the body, are black.

WORK FOR THE WEEK.

KITCHEN GARDEN.

WHEELING out manures, composts, earth, mud, &c., and trenching, draining, making new walks and repairing old ones, are amongst the principal operations at the present season in this department. Always make choice of suitable weather for them, with a view to cleanliness and good order. Take care to pot or lay in a sheltered situation *Cape Broccoli* and *Grange's White Broccoli*. *Celery* must be carefully earthed-up in suitable weather, and a supply of *Endive* must be blanched. *Jerusalem Artichokes* keep well and in good condition for use in the soil, and can be taken up as required; to keep the frost from injuring them, the stalks may be cut off within 5 or 6 inches of the surface of the soil and laid between the rows, or a quantity of leaves, mulching, or vegetable refuse may be wheeled amongst them to cover the surface of the ground. The best plan with *Parsnips* is to let them remain in the ground and trench them out fresh as required for use. At this season of the year, it is advisable to have wheeled on and spread over them a good coating of manure or mulching material, so that if frost set in it may always be easy to get at them. Clear away dead leaves from all growing crops, and fill up blanks as they occur.

FRUIT GARDEN.

Continue to prepare for fruit-tree planting by draining, trenching, and pulverising the soil; and after planting, stake, tie, and mulch them securely in good time. Clear away all dead leaves from the wall trees, and remove the green fruit from the Figs. The established strong-growing fruit trees that

are tardy in producing fruit should be root pruned. This operation must be performed according to circumstances; if the trees are planted too deeply, or the soil has been raised above or about them since planting, by all means fork the roots out carefully, and plant them again with care on the surface, spreading them out judiciously, and then mulching them. If trees to be operated upon are planted high and dry, fork about them at a reasonable distance, and prune back the main or strongest roots as you discover them. Very beneficial results follow from such an operation when performed judiciously. Raspberry plantations may be cleared of the dead canes and superfluous wood; the suckers should be taken off, and where required the strongest should at once be planted for succession.

FLOWER GARDEN.

Dahlias temporarily placed heels upwards under cover to dry, should now be carefully stored away for the winter. See that coarse-growing plants which may be encroaching upon their weaker neighbours are reduced, so as to occupy their proper places. Gladioli may still be planted, but most kinds of bulbs are now better in the ground than out of it. For Gladioli choose a warm, thoroughly-drained situation, work the soil well by deep digging, and add plenty of rotten manure. Elevate the bed or patch a few inches above the general level, plant the bulbs 5 or 6 inches deep and 6 inches apart, surrounding them with 1 inch of sand before covering with mould, and protect them during the winter against excessive wet and frost by means of a thick layer of sawdust, old tan, dry litter, and old carpet, thatched frames, or tarpaulin. The last three coverings must be removed during favourable weather, and the former covering entirely cleared off when the plants appear. Ranunculuses may also still be planted. The situation of the beds should be cool and somewhat moist; at the same time there should be good drainage. The most suitable soil is a hazelly loam. If, therefore, the natural soil is unsuitable, remove it to about the depth of 2 feet, and 4 feet in width, replacing it with rich loam from an old pasture; this ought to be rather firmly trodden in, and should form the foundation and principal portion of the bed. On this should be laid a liberal dressing of well-decayed manure, mixing it a little with the under soil, and over all, for the top of the bed, should be laid a layer of soil 6 inches deep for planting the tubers in; this soil should be stiffish loam, fibry, and mixed with well-decayed cow dung and leaf soil. Draw drills 6 inches apart and 2 inches deep with a small hoe, and plant the tubers 4 inches apart, with the claws downwards, gently pressing them into the soil. The crowns of the tubers should be at least 1½ inch under the surface of the bed. The beds and borders intended for Roses should be thoroughly trenched and turned, at the same time adding plenty of rotten dung, which should be well incorporated with the soil as the work goes on. This is considered to be the grand secret in Rose-growing, as without attention to this it would be vain to expect umbrageous trees or, indeed, an abundance of bloom. Of all months in the year the present is decidedly the best suited for the removal and planting of hardy summer Roses. In lifting the plants great care should be exercised to preserve as many roots as possible; avoid wrenching or straining the roots in lifting. Prune the ends of broken roots, and cut away all suckers. Deep planting is to be deprecated. Standards should be secured to stakes as soon as planted. When all this is finished fork up the surface as roughly as possible, get protecting materials in readiness, such as Spruce boughs or Furze, also dry Fern or Moss, to be applied to the most tender sorts when severe weather sets in. If possible, keep the material dry till required. To save time at another season old-established shrubs should now be gone over and pruned by shortening or removing all uncouth or straggling branches, taking care to cut in such a manner that the foliage will conceal the incision made in the branch. Proceed with the planting of evergreen and deciduous trees and shrubs. Devote any spare time or bad weather to preparing protecting material, which will be required for delicate trees and shrubs that cannot fully withstand the severity of our winters.

GREENHOUSE AND CONSERVATORY.

If the different varieties of half-hardy Lilliums are subjected to a successful mode of pot culture, they will prove most desirable objects during the summer and autumn months for the decoration of either the conservatory or greenhouse. The sorts most in repute at present for this purpose are the splendid varieties of recent introduction from Japan. The present is the best period of the season for the general potting or transplanting of Lilliums; their flower-stems are now sufficiently withered

to allow of their safe removal without injury to the bulbs, and potting thus early will enable them to thoroughly establish themselves previous to the flower-stems making a start. That they should be so established is very necessary, and of much more importance in the cultivation of this class of bulbous plants than is generally supposed. Of scarce sorts any small bulbs that may have formed on the flower-stems should be saved, and be potted separately in small pots, or planted out in a pit or frame in suitable soil, where in a year or two they will make strong flowering bulbs. If the object of the cultivator be to grow the old plants into fine large specimens, the bulbs must not be divided too much, but remove carefully as much of the old soil as can be conveniently done without disturbing the roots, and then let them be placed at once in the pots in which it is intended to flower them, which ought to be thoroughly drained, and of a deeper form than those in general use. The soil most suitable for the cultivation of Lilliums is a rich fibrous heath soil used in a rough state, and without any admixture of other soils, with the exception, should the nature of the heath soil require it, of a portion of silver sand. After potting let them be placed in a cool part of the greenhouse or in a cold pit, protecting them from severe frost only, and giving them a very limited supply of water until next season's flower-stems appear above ground, when a gradual increase will be requisite.

COLD PITS.

Cold pits afford the best possible accommodation for the culture of all greenhouse plants in summer, but unless they are furnished with pipes so that a little heat can be had to dry the atmosphere occasionally, and also to exclude frost, they are not fit quarters for many plants in winter; and although in mild winters most greenhouse plants can with care be wintered in cold pits, such as *Boronia*s, *Leschenaultias*, *Gompholobium*s, &c., if not already done, should be removed to safer quarters at once.—W. KEANE.

DOINGS OF THE LAST WEEK.

The prognostics as to the weather have been fully realised. On Sunday, the 13th, we had from 3 to 4 inches of snow, which rapidly thawed and disappeared, but almost every night we have had a sharp frost, getting more keen towards morning. These frosts from the 12th to the 19th destroyed our flower garden display. The *Colenees* succumbed three weeks ago. The *Irenee* was splendid until the 12th, or rather the 15th, for it stood the snow well. *Calceolarias* are as yet but little affected, though of course the flowering is nearly over. Some scarlet *Geranium*s elevated and rather dry in vases seem, with all the frost, to be yet sound to their points. No doubt the dry summer helped to make them more firm, and therefore less liable afterwards to suffer from the extremes of heat and cold.

Some years ago, as hints to young gardeners in managing fires, &c., we remarked that the state of the moon ought to form a part of their considerations. As a general rule the greatest cold in winter is felt just before daybreak. A brisk sharp fire in the morning will, therefore, often supersede the necessity for having large fires at night. Another secondary rule may be deduced from the state of the moon. When the moon is growing to the full the coldest temperature is generally experienced in the evening and onwards until the moon sets. At new or full moon we can scarcely calculate on much difference from sunset to sunrise, but when the moon is waning and giving its light in the early morning, it is well to provide for a fall of temperature then, especially if the sky is unclouded. During the last week, with a west and even a south-west wind prevailing up to this day, the 18th, we have had with rather mild evenings sharp frosts every morning. Most likely this will change as the moon changes. We by no means assert that such a rule is at all general: no doubt every reader could give us plenty of exceptions, but still the bulk of facts would seem to say that in a waning moon we have the lowest temperature in the morning, and that therefore a sharp fire, or a little protection before it is quite daylight, is of more importance than piling on fire or extra protection in an evening comparatively mild.

In many places it is getting customary for garden assistants to get up and take their breakfast before going out to work in the winter months. This not only makes a long period between breakfast and dinner, and puts men who live at a distance to an additional expense for fuel in the morning, but keeps them away from the garden early in the morning, when a little firing and protection would be not only most serviceable,

but most economical. A considerable amount of observation leads us to the conclusion, that men who can get a comfortable warm breakfast at 8 or 8.30 a.m., and whose comfort is otherwise cared for, will work better and wear better than other men who scarcely have a comfortable meal in summer, except the one they get in the evening; and if they have an early breakfast at home in winter, it is attended with extra early rising, and extra expense for fuel if they have everything comfortable and warm as they ought to have.

In these times it may be too true that working men may have been too selfish in studying what they thought were their own interests; but on the other hand, it is also too true that many employers do not pay so much attention to the comfort and health of their workmen as they do to the cleanliness and dryness of necessary machinery. We know of cases where, even as a matter of making the most of the hours of labour, garden men are expected to be at their work at seven in the winter and early spring months, and to have breakfasted previously. Now, work can be very well managed on this plan, but where economy in labour and in fuel are to be considerations, not to speak of the comfort of the men, we have a strong belief that from half an hour to an hour earlier at times in the morning, even though stopping for breakfast afterwards, would be the most economical mode in the end.

KITCHEN GARDEN.

The work has been to a great extent a repetition of that recorded in the previous week's notice. We pricked out more Cauliflowers, Lettuces, &c., and protected Lettuces and Endive, not covered up, for present use.

Wheeling Manure, &c.—In the frosty mornings the contents of the rubbish-heap that had been well mixed and heated, were wheeled on to empty ground; we also wheeled the remains of hotbeds into heaps, whence the material could be moved where wanted afterwards, without breaking-up walks. All wheeling on walks should be done either in frosty or dry weather. We have felt as if a blow had been given us, on noticing men pushing and striving with all their might to get a barrow along with the wheel up to the axil in mud and slush. Much depends on choosing the right time for work, if the work is to be done comfortably and economically. In particular cases such continuous work cannot be avoided, but, as a general rule, no work should be attempted which cannot be done at the time without making other work. When for short distances we are obliged to wheel in unsuitable circumstances, a great preservative from injury will be found in thinly sprinkling the place to be wheeled over with longish litter. Even under the most favourable circumstances, a similar sprinkling for some yards from the rubbish or dung heap keeps the wheel of the barrow and the feet of the wheeler clean, and thus the walks and ground wheeled over are kept comparatively unbroken. It is true they might be scraped and swept, but the less the better. Much of it is just doing work so as to make other work, a matter to be avoided when economy in resources is to be considered. A dry frosty morning is, therefore, very suitable for general wheeling; but if the frost is very sharp, and the ground hard, it is not desirable to wheel over lawns, as under such circumstances the grass under the wheel of the barrow will long retain a dark injured appearance, when the rest of the lawn looks like a fine green carpet. We have known several cases in which beautiful small lawns have thus been greatly injured in their appearance far into the summer. Nothing would take out the wheel marks. Where wheeling must be done in such cases, it would be well to use boards and planks to wheel on, and thus save the grass.

Ice.—As we stated some time ago, it is very easy to use too much ice in hot weather in summer. What is very pleasing is not always conducive to health. Still, without ice many would have found the last season very trying to the temper if nothing else. In our common sunk well, with only a single wall, we have had and still have abundance; this is all the more gratifying, as, from our ponds having still little water, we should have far to go for ice, even if the frost were coming sharp enough to give us plenty on clean water. We are reminded by the short statement at pages 390 and 391, that we promised some dozen of our correspondents to say a few words before another season as to the causes of their failures. Well, in eight cases made known to us, where ice heaps had been made above ground, chiefly for milk, cream, and butter purposes, the ice had thawed when most wanted—in July, and later. In these cases the ice had been well broken, but it was left too wide and flat, and there was too little of it to give hopes of keeping. In the largest heap there were not above fifteen good cartloads. Now, though we do not wish to dis-

courage anyone, still we could not recommend the forming a heap expected to last over the summer, unless there were from thirty to forty good cartloads. It requires very great care to keep a few loads over the late spring and early summer months. In six cases made known to us, the failure, we think, was owing to using dryish litter, but not dry, to cover the heap out of doors; and the litter banked together, heated enough to melt the ice. When the ice is packed firmly where no water or ice-meltings can stay, and where, if possible, the ice has been watered outside and frozen into a lump, nothing is better for covering than, say, 6 inches of dry straw, more being added by degrees, so as to keep out heat, and yet not heat by fermentation. For the outside covering we have found nothing better than dry tree leaves, for if put on with a few branches over them the wind has little effect on them, and the heat of the sun scarcely any. Without these wheat straw neatly secured is the next best, put on so as to throw all wet from the inside covering. Such dry covering put on by degrees should not be less than 18 inches thick to keep out effectually the heat of summer.

In several cases where ice wells have been made under ground the failure was owing either to not having a drain at all, or having a drain, but untrapped with standing water, and therefore admitting the air of the general atmosphere in summer to the bottom of the well. A moist foggy atmosphere would thus be formed in the place, and nothing tends to melt ice more quickly. The more cool and dry the air over and about the ice the better it will keep. The moister and warmer the air is the sooner it will melt.

Reverting to the notice at page 390, we observe that a mistake was made, inasmuch as the inside wall was 9 inches thick instead of 4½ inches, the thickness of the outer wall. Be that as it may, we revert to the subject again because, from several notes, we find that though most people have an idea that double walls would alike keep out heat and cold, they cannot see, except through a sort of mist, that the most thorough acting of such double walls depends on the air enclosed being still—thoroughly shut in, and having no connection with the external atmosphere. We have been asked how it is, and as we never could satisfy ourselves as to the how, it is not likely that any answer we could give could satisfy others; nevertheless, the fact remains that whilst moving air is a good conductor of heat and cold, confined air is one of the best of non-conductors.

We will adduce a few facts in corroboration. First, A few years ago a doubter as to this property of confined air called upon us during a keen frost in January, after 2 or 3 inches of snow had fallen the previous night. He looked at a low house about 11 a.m. One half of it had a cloth run along the front lights, the inside temperature ranging from 45° to 50°; the other half had neat straw covers placed on the lower sashes instead of the cloth. There was not a ray of direct sun that day, but a cold clouded atmosphere. Well, as there was not much reason for uncovering early, at that hour the snow on the cloth lying against the glass was all melted and gone, and the cloth could be easily rolled up. But above the warmer house the snow lay on the straw covers just as it had fallen, not a bit of it showed any signs of melting. We attributed this to the air enclosed imperfectly between the glass and the cover, and the air so far shut up in every tube of straw. For such a purpose, the less mutilated the straw by flail or machine the more suitable it would be for such a purpose. We regret we are getting out of straw covers. Made as recommended in former volumes, there is no protection cheaper and more effective.

Secondly, We have a pit which we had built with hollow walls—that is, a 14-inch wall used-up little more bricks than a 9-inch wall. In the most severe frost we have never known the inside wall at all frosted. In the hottest summer weather the inside wall, unless where the sun beats upon it, is comparatively cool.

Thirdly, A gentleman was obliged to build a dairy in a rather exposed place. As far as we recollect there were double walls, but we forget whether they were 14-inch or 18-inch, double ceilings, and a double roof; but like our correspondent, "G. Y. M.," he would insist on there being a thorough circulation between the walls, ceilings, &c. The circulation of the air was to keep all right, and in the hot summer the milk soured, the cream moulded, and the butter run to oil. When the air became thoroughly confined, visitors on going into the pretty place in August and September exclaimed, "Oh, how nice and cool! so like an ice house!"

Lastly, for the present. Few who travel by rail between thirty to fifty and more miles of the metropolis could fail to notice, chiefly in the morning and evening, trucks and vans filled with long upright tin cans, which help to supply our great metropolis with milk, cream, &c., from the country. The chief difficulty is to get it sweet and fresh by rail from rather long distances. A friend of ours who does a large trade has, we believe, not had a single complaint for several of the last dry and hot summers. He first tried double-sided vessels, and filled the space between with ice and iced water; then, as ice failed, he tried cold spring water; then, like "G. Y. M.," page 390, he thought if there were openings at top and bottom for the air to circulate between the outer and the inner case, all would be well; but it was not well. The simple mode has been returned to of leaving well alone. The holes are securely corked up. The air in the space between the cases, say from 1 to 1½ inch in width, is kept still and confined, and with the good results above specified. That body of confined air would prevent the hottest sun acting on the milk inside far more effectually than if the space had been filled with the coldest iced water. Confined air might be used with good effect for many purposes in gardening, as well as for keeping ice houses cool.

We can only now find room for three hints. First, in such weather as that which we now have let air-giving be moderate, and chiefly at the top of the house, and that after the heat is rising. Air given at the top gets mollified before it reaches and refreshes the plants. Letting cold blasts of cold air into plant or tropical houses is all a delusion. Secondly, be cautious of firing, so as not to give too much heat in dull, cold, cloudy weather. Less cold air will be necessary if there is less use of the furnace. Study the weather, and give a little brisk fire early in the morning in preference to a high temperature at night. Thirdly, for most plants under glass use water from which the chill has been taken, say not colder than 50°; for tropical plants not under 60° or 70°; and in cool greenhouses, &c., especially avoid spilling any.—R. F.

TRADE CATALOGUES RECEIVED.

W. Cutbush & Son, Highgate, London, N.—*Descriptive Catalogue of Stove and Greenhouse Plants, Fruit Trees, &c.*

F. & A. Dickson and Sons, 106, Eastgate Street, and Upton Nurseries, Chester.—*Catalogue of Forest Trees, and Hardy and Ornamental Trees and Shrubs, &c.*

TO CORRESPONDENTS.

* * * We request that no one will write privately to any of the correspondents of the "Journal of Horticulture, Cottage Gardener, and Country Gentleman." By doing so they are subjected to unjustifiable trouble and expense. All communications should therefore be addressed *solely* to *The Editors of the Journal of Horticulture, &c.*, 171, Fleet Street, London, E.C.

We also request that correspondents will not mix up on the same sheet questions relating to Gardening and those on Poultry and Bee subjects, if they expect to get them answered promptly and conveniently, but write them on separate communications. Also never to send more than two or three questions at once.

N.B.—Many questions must remain unanswered until next week.

BOOKS (*A Young Gardener*).—Chambers's "Arithmetic, First Course." (*Anxious*).—Hogg's "Fruit Manual" is out of print. Another and enlarged edition is preparing. (*A. H.*)—Upon the receipt of thirty-two post-office stamps with your direction, the "Pine-Apple Manual" will be sent to you post free. The "Florist and Pomologist" is published monthly.

ITALIAN SPRING GARDEN (*Huzlehurst*).—We have no doubt that the proposed planting of the Italian spring garden will look very well. We are rather surprised that you have no Crocuses, which would have told well. We would use all your 4's alike—yellow Tulips with blue Pansy edgings. The four 7's, white Hyacinths, we would surround with blue and purple Crocuses, or the Swiss Forget-me-not. The four 5's, scarlet Tulips, we would surround with white Crocuses, and striped blue Crocuses. The four 8's, Nemophila beds, we would border with yellow Crocuses; 9, beds of Rhododendrons, we would border with Snowdrops, and carpet with Silene pendula. The four 10 beds, border with Daisies; the four 11 beds, border with yellow Crocus.

PANS for AN ORCHARD (*Wyeside*).—In addition to the Seckle and Chamontel, which you have, plant Jargonelle, Louise Bonne of Jersey, and Winter Nells.

FRUIT TREES FOR EAST AND NORTH ASPECTS (*Warburton*).—A wall with an east aspect will suit a Chamontel and Beurré de Rance Pear, but for the former a warm soil and situation are necessary. Pears for the east well—Bergamotte Esperen, Beurré Bose, Marie Louise, Glon Morveau,

Joséphine de Malines, Passe Colmar, Crassane, Van Mons Léon Leclerc, and Ne plus Meuris. Of Plums you may have Green Gage, Jefferson, Coe's Golden Drop, Kirke's, Transparent Gage, Prince Englebert, Victoria, and Oullin's Golden. The north wall will only suit the Morello Cherry.

BLACK ALCANTHE GRAPE SMALL AND STONELESS (*Wyeside*).—The Alcanthe requires rather more heat than the Black Hamburgh. To make the berries stone and swell, before doing anything else to the Vine, we would pull the dry hand gently over the bunches when in bloom. If the hand were well powdered with the farina from other kinds, all the better. If afraid to use the hand, which answers admirably, use a soft camel-hair pencil, and have a little of the dust of other kinds on clean paper held below, and you can scatter it over the bunch in bloom.

VINE (*X. Sidmouth*).—It is a species, *Vitis laciniata*, the Parsley-leaved or Clotat Grape Vine.

PLANTING A SMALL COOL VINERY (*A Poor Working Man*).—We think the proposed construction of the vineery good. You can grow Grapes very well in an unheated house, but it should have a south aspect. We would so contrive that the border should be partly above the surrounding ground level, and entirely so if the situation is wet. Plant inside at about 1 foot from the front. You will have room for six Vines; plant the two end ones 15 inches from the ends, and divide the space equally into five parts, which will show you where the four Vines should be planted. Plant in spring just when the Vines are beginning to grow, or in March. Of kinds, we would have one Black Champion, two Black Hamburghs, one Foster's White Seedling, one Buckland Sweetwater, and one Trent-ham Black.

ARRANGING A FRUIT GARDEN (*A Cottage Gardener*).—We think your former plan much the best—i.e., a 12-foot border and a walk 3½ feet wide all round, with a centre bed or border of 12 feet. This we would dispose as follows: Take off at one end what you require for the ground vineries, leaving them with their ends north and south; but irrespective of them, we would have a row of cordon Apples all around, and then two rows of pyramid Pear, Apple, Plum, and Cherry trees, and devote the space between to Strawberries. You can devote the ground to bedding plants and Roses. To grow both well the centre bed would not be too large; but to mix flowers and fruit trees together is to have neither good, and we thought your original intention was to make your garden profitable. Flowers take from, instead of putting in the pocket.

GREENHOUSE ON EAST ASPECT—HYACINTHUS IN POTS (*H. H. M.*).—A greenhouse will answer on a site that gets all the morning sun up to one o'clock. To forward Hyacinths which have been potted some time they may be placed in a mild hothed; but if they are only newly potted they would do best plunged in sawdust in a cold frame.

SOIL FOR A MAGNOLIA (*J.*).—We have seen the Exmouth variety doing well in a compost of loam from rotted turves, the turf being pared off about 3 inches thick and laid up for six months. The turf was taken from a pasture where the soil was a strong or heavy loam. This we consider the best of soil for the plant, though it may sometimes be seen doing well in a peaty soil. For top-dressing nothing is so good as cow dung, but sheep droppings answer well.

HIDING BUILDINGS (*Leadbeater*).—We think the proposed poles and covering them with climbers would not be effectual. The finest screen we know would be of *Cupressus Lawsoniana*. A double row of this—the plants being 6 feet and the rows 3 feet apart, planting them in quincunx order—would give you a complete and beautiful screen in a few years. To form one more rapidly you might have a double row of *Thuja Lobbi*, as advised for the *Cupressus*; or you could obtain strong plants of the American *Arbor-Vitæ* that would be a block at once, and they may be planted so as to form a hedge. Plants 6 and 8 feet high can be safely moved.

PERIS SERRULATA VARIETIES—FILMY FERNS (*Fanny Fern*).—*Pteris serrulata cristata*, *P. serrulata polydactylon*, and *Pteris umbrosa* are all as hardy as *Pteris serrulata*. *Trichomanes radicans* will succeed in a moist atmosphere without watering over the fronds, and it will also succeed when the water is given over the foliage. Constant moisture is the first object to be aimed at, and we think it well not to water over the foliage. We have found it do best in a position where it is kept moist by a little water constantly dripping on the stone or near where it is growing. *Hymenophyllum tunbridgense* does not require so much moisture as *Trichomanes radicans*. It is best covered with a bell-glass and water given below. It also does not require to be so dark, but should be kept from bright sun.

EARLY TULIPS IN POTS (*D. M.*).—If you wish the Van Thol Tulips in pots to flower early, you may place them in the house, now that they are pushing above ground; give them a temperature of from 55° to 60°, and a position near the glass; when the flowers show colour, remove the pots to the house with a temperature of 49° to 45°, and the flowers will be finer and last longer than in the higher temperature. If the Tulips are not wanted for blooming early, they would do better in the last named temperature, in which they would flower from the middle of February.

TOP-DRESSING LAWN (*H. Fox*).—Cocoa-nut fibre, turf-parings and phosphate of lime would be an excellent top-dressing for a lawn. The phosphate we should prefer to salt. We would now have equal parts of the cocoa-nut fibre and turf-parings well mixed and turned over in a heap, and we would at the end of February turn the heap again, adding to it one part in ten of phosphate of lime. You may give the dressing at the rate of twenty cartloads per acre. Put it on in March, let it lie until the beginning of April, then rake the lawn well, and sow the lawn grass seeds as you propose, not being sparing of the Suckling Clover (*Trifolium minus*). Roll well after sowing.

CENTAUREA CANDIDISSIMA CULTURE (*Idem*).—That is the name of the plant of which you enclosed a leaf, one of the best white or silver-leaved plants for bedding. It requires to be taken up before frost, to be potted in light sandy soil, and to have a light airy position in a greenhouse, not giving much water—only enough to keep the foliage fresh. If safe from frost it is sufficient.

PLANTING LILIUM AURATUM OUT OF DOORS (*C. E.*).—You may now plant bulbs in the open ground, in good, rich, light soil well drained. A peaty soil is most suitable. Surround the bulbs with sand, and cover them with 2 or 3 inches of light soil.

PLANT FOR A SHADED WALL (*A. B.*).—Having tried Cotonaster, we fear your only hope is Ivy. The variegated kinds are, as a rule, of weaker

growth than the green-leaved. We would try *Hedera rhombœa variegata*, and argentea major, two of the most free-growing variegated sorts. The New Silver-striped is, however, one of the finest. We should plant the Irish Ivy and Regner's Ivy (*H. Regneriana*), the finest of all the green-leaved sorts.

ROSES IN POTS (G. B.).—The Roses having been potted in spring we would not now shake them out and repot them, but we would see that the drainage was good, making it so if it did not prove satisfactory. Then remove the surface soil down to the roots, and replace it with fresh rich compost. The Vines in pots, not of a size fit for fruiting, we would at once cut down, shake out, and place in pots suitably large to hold the roots without cramping. Of course, you will shift the Vines into larger pots when they have started into free growth, giving the fruiting size by May.

BRIARS FOR ROSE STOCKS (Marchal Niel).—The Briar for budding is not the Sweet Briar, but the Dog-Rose Briar. Select out of the hedges stems with clean, healthy bark and firm spines. Take them up carefully with a mattock, and cut the jagged ends of the roots to a uniform radius. Cut off all the branches, and head the Briar back to the required height. They should not be, except for pendulous or drooping trees, more than 3 feet high, as if the sort budded should grow well you cannot see the blooms without pulling the twig down. Eighteen inches or 2 feet I think the best height. If the sort budded do not grow well, one of two things will happen—either the Rose will deteriorate the Briar, or the Briar will deteriorate the Rose. Briars with bad growers on them are soon covered with Lichens or Moss. A wash of fresh-slaked lime and a little salt dissolved in water is the best cure for this. After planting the stocks mulch them, and keep them mulched next summer, and well water the roots two or three days before budding, also occasionally afterwards. After budding the Briar, tie a leaf over the bud for a day or so. Nurserymen do not usually sell Manetti cuttings.—W. F. RADCLIFFE.

ROSE CUTTINGS (Capt. G.).—Some of the hardiest Hybrid Perpetuals will strike from cuttings taken off the tree and put into the open ground in November, but it requires a favourable soil and situation. The wood should be well ripened, and with a heel to it—i.e., a side shoot of the current year's growth taken with a piece of the branch from which it sprang. The soil must not be too heavy, and the rows where the cuttings are planted should not be exposed to the full sun. The percentage, however, of failure is in most places very great, and far more satisfactory results can be obtained by taking off cuttings in August and September, and striking them in an old spent lotted or Cucumber frame, putting a layer of fresh soil with a little sharp sand at the top, and keeping the frame shaded and close at first. Protect in winter, and allow the cuttings to remain till spring, when they can either be potted off or planted out in nursery rows. Cuttings will also strike in pots in a cold frame with proper attention to shading and watering. Roses can likewise be obtained on their own roots by layering, where they are grown as dwarfs on the Manetti.

SELECT ROSES—TRANSPLANTING THEM (Spatius).—I do not know why Compe d'Hebe was called the "Queen's Rose." The thirteen Roses which you gave your friend are a good collection. As you wish to give another dozen or so I name Madame Victor Verdier, brilliant red; Pierre Notting, purple red; William Griffiths, salmon rose; Madame Clémence Jougou, deep rose; Marie Radé, carmine crimson; Felix Genere, redish rose in the centre, with silvery liliaceons reverse to the petals; Dr. Andry, brilliant red; Maurice Bernardin, deep vermilion red; Abel Grand, silvery rose; Duc de Caen, crimson purple; Victor Verdier, warm rose; Triomphe de Rennes, canary or golden yellow; Jules Margottin, crimson. I add two rather new Roses, both good growers on the Manetti (as, indeed, all the above are), which gave me great satisfaction last season: they are Edouard Morron, deep rose, and Souvenir de M. Poiteau, soft rose. As long as Roses do well I do not move them. If they do not flower, or if they produce long blind wood, root-prune or remove them. If you remove them to your semicircular mound, put the tallest in the centre, and graduate the others. In some soils Manetti-stocked Roses require to be moved biennially, or they do not bloom well in the autumn. At once remove what you mean to move, mulch them over the roots, and draw the earth over the mulching like a mool-hill. Mine are served so every winter. I lost only one Rose last winter and one this trying summer, out of 2000. I kept on two waterers for ten weeks, or I should have lost, as others have done, hundreds of my Roses. You can train your vigorous Charles Lefebvre as a pole Rose. Do not cut away altogether the lower portion; shorten the main stem one-third. Charles Lefebvre breaks chiefly from the top of the shoot; you must therefore encourage the wood that is now at the base of the plant. If you have no low furniture you had better cut the Rose down to within 12 inches of the base. The best two dark Hybrid Perpetuals for pole Roses are Empereur de Maroc and Pierre Notting.—W. F. RADCLIFFE.

WILLOW WITH CURLED LEAVES.—"Several years since I had in my garden a species of drooping Willow, in growth and size like the common Weeping Willow. It had, however, a peculiarity in regard to the leaf, the upper surface of which was of a beautiful shining dark green, the under surface being covered with a short, white, fine cottony down. These leaves were dependent, and each made two or three spiral turns, thus showing alternately a varnished green surface and a downy light one. This tree I possessed many years, but an early frost entangled in it the spray of a fountain beneath while my tree was in full foliage, thus loading the Willow with thousands of icicles, the weight of which split the tree in quarters, and utterly destroyed it. I should like to know something more of this species of Willow; perhaps some of your many readers could give me a few words of information. I should also be very glad to become a purchaser of a young plant, and so repair my loss.—C. BAILEY, *The Cliff, Chippinham*." [We think that the Willow was *Salix babylonica*, var. *crispata*. It is described, and the leaves figured, in London's "Encyclopedia of Trees and Shrubs," and in Forbes's "Salix Woburnensis."]]

HOSE SWEAGE (E. B.).—Mix the sewage with the soapuds. Pipes would convey the mixture to any part of the garden, as there is a considerable fall. A tank to which a vulcanised Indianrubber hose could be attached would probably be available.

HOT WATER NOT CIRCULATING IN PIPES (J. S. Milton).—For anything we can perceive to the contrary, the feeding cistern to your boiler is all right, and so is the flow-pipe attached to the top of your boiler; but that is of but little importance compared with having an air pipe at that

corner where you have marked the rise of the pipe as being 3 inches from the boiler, and the rest of the pipe on a level, until coming near the boiler it drops 2 feet. The first thing, therefore, to do, is to drill a hole at the highest point of your pipe, and fit there a gas pipe from one quarter to three-eighths of an inch in diameter, leaving the upper end open, and 2 or 3 feet higher than the supply cistern, and with the end bent over and downwards. This will be your great safety valve. But, secondly, in such a small house, it is easy to make the water very hot, and there must be room for expansion. Careful firing is, therefore, necessary, so as not to give the water too much heat. We would rather have more piping in a house than have limited piping over hot. You will do no good without the air-pipe. If the top end go outside the house all the better.

FIXING HOT-WATER PIPES (A Constant Reader).—On the whole, perhaps, there is no plan better than filling the joints with iron filings and salts of ammonia. If filled too tight and full the joints are apt to crack. If a base of tow or lint is used we question if anything is much better than red or white lead. With a similar base at the socket of the joint, we are sure that Portland cement will answer well if properly put on, where there is no extra heat nor pressure. We think you will find they will answer in your greenhouses. The pipes in most, if not all, the forcing houses at Woodhall, were jointed by Mr. Beales with such cement, and no pipes could be sounder nor stand better.

HOT-WATER PIPES FOR VINEY (T. H.).—We see nothing to prevent the proposed plan answering, only to have Grapes ripe in May we would not be satisfied with less than four 3-inch pipes—two as flows along the front, round the further end, and then as returns along the back. We would prefer the flows to go along the front as you propose, and the returns at the top of the raised border at back, instead of the bottom of the passage. See answers to a correspondent about having the pipes near the soil, an advantage in your case, also as to air pipes at the highest point of the pipes.

HOT-WATER PIPES ON VINE BORDER (T. H. D.).—We see no inconvenience in having your heating pipes merely the thickness of a brick above the inside Vine border. They would not heat the soil too much. They will tend to dry it, it is true, but all the better for the border filled with roots, as then you can water the often with weak clear manure water. If you would rather lessen heat in your border, and as a consequence lessen evaporation from it, place a thin board below the pipes, or common slates, painted white on the exposed surface. Were we in your case, however, we would let well alone, and just use a little more water than would otherwise be necessary.

DESTROYING WORMS ON LAWN (G. S. I.).—As you have tried lime water it is useless for us to advise that, though we think you have applied it much too weak. 12 lbs. of slacked lime to 33 gallons of water stirred well up and allowed to stand two days, and the clear liquid applied to the lawn in moist weather, the lawn being well rolled the previous evening, will mostly prove effectual. Ammoniacal liquor from the gasworks diluted with six times its volume of water will also destroy them, but has the disadvantage of making the lawn look rather bare for a time afterwards.

NAMES OF FRUITS (Cumbria).—Cox's Orange Pippin. (*H. Harpur*).—Emper Alexander. (*J. H.*).—1, Passe Colmar; 2, Red Doyenne. (*A Subscriber*).—1, Joséphine de Malines; 2, the clear of Winkfield; 3, Triomphe de Jodogne; 4, Vicar of Winkfield; 5, Doyenné Boussoch; 7, Van Mons Leon Leclere; 8, Chaumontel.

NAMES OF PLANTS (Gambetta).—1, *Salaginella apus*; 2, *Brannii* (the *S. pubescens* or *S. Willd.-novii* of gardens); 3, *S. Kraussiana* (*S. hortensis*); 4, (*E. Emera*).—*Tecoma radicans*. (*E. S. C.*).—1, *Polystichum angulare*; 2, *Cystopteris fragilis*; 3, *C. fragilis*, var. *dentata*; 4, *Athyrium Filix-femina*. (*M. R.*).—1, *Lastrea spinulosa*; 2, *L. diitata*; 3, *Adiantum hispidulum*; 4, *Nephrodium molle*; 5, *Pteris longifolia*. (*St. Kenon*).—*Eucynurus europæus*, the common Spindle tree or Prick-wood, so called because skewers are made of it.

POULTRY, BEE, AND PIGEON CHRONICLE.

THIS SEASON'S MOULT—PREVENTING PULLETS FROM LAYING.

My experience with regard to the moulting of my birds has this year been rather peculiar, several of them, both old and young, having moulted twice over. One or two Brahma hens, which moulted very well and quickly rather early in the autumn, are now in the midst of a second and much more lingering renovation, while nearly all show more or less signs of it. One or two have suffered severely, not from any complaint, but having lost many pounds in weight through the drain upon the system, they became almost like skeletons, a rather fine hen being at one time reduced to little more than 4 lbs. weight. Others, again, appear to have only gone through the usual process in an average manner; but these are chiefly hens which commenced late in the year.

Chickens, as is well known, do not experience a regular "moult" the first year, but the chicken feathers are gradually and imperceptibly exchanged for the adult plumage. This autumn, however, several, both of my pullets and cockerels, after nearly completing this normal process, are now in the midst of a regular moult, which entirely spoils them for showing. I have often found such a thing occur with early pullets which have become broody; but none of my birds were hatched before April 9th, and except one, which I sold some time since, not one has yet laid an egg. The best marked pullet I have, hatched in the middle of April, was in full plumage a month

sine, but has now about half replaced her hackle and breast-feathering, her leg-feathering also having almost disappeared. Two more are nearly in the same condition; and a very large cockerel, the largest I think I ever reared, is moulting all over the breast, fluff, hocks, and saddle, though the neck hackle is not yet grown. The flights also have nearly all dropped, and are being replaced by new ones. Another cockerel partakes of the same process, though not to such an extent, whilst the other three show no sign of it whatever.

It may be that the very hot and dry summer we had has caused the phenomenon I speak of; but as it is new to me, I should like to know whether any other readers have had a similar experience, and, if so, whether any of them have found any successful means of prevention.

I have already remarked that, with one exception, none out of a dozen pullets has laid an egg. I mention it because it is often said that there is no means of postponing the period of laying, while my experience leads me to think differently. Last year I fully satisfied myself that change of scene, combined with non-stimulating food, would postpone the period, if desired, for nearly two months, and this season I tried the experiment for the first time on all my birds. In such summers as that of 1870, a Brahma hatched in April will generally lay some time in September, or even before. About the middle of August I changed them all from one pen to another, moving each lot to a run entirely out of sight of the former one, repeating the process about every four weeks, and giving no meat nor other stimulating food. Only one has laid, though several are almost seven months and a half old; whilst last year I had pullets laying by this time which were hatched in May. I know another fancier who uses the same means with the same results, and, indeed, I believe it is no secret among experienced exhibitors; but some who may, like myself, have to gain their own experience at their own expense, may perhaps be glad of the hint.—L. WRIGHT.

TRIMMING—PRIZES, &c.

THE number of November 10th was so full of subjects of interest to us poultry lovers that it must be my excuse for inflicting rather a long epistle. So at once to Mr. L. Wright's capital communication about trimming and other deceitful practices. I must quite agree with him that his efforts have borne much fruit. Several shows have made a marked regulation about trimming and similar practices. It may be said they did this before, and this is true, only that before it was worded in such a way that the judges took little notice of it. Now I know one or two instances this year where Mr. E. Hewitt disqualified birds painted, &c., and there is certainly in the prize schedules a general tone of improvement in this respect which augurs well; but as long as we allow that in Game and Spanish art can improve nature, we are leaving a loophole for these practices in other breeds.

I may hazard the opinion that these gross cases grow upon us, and that the beginnings of the evil are small. I have at the present time a bird that I could wish would learn to paint itself on one or two feathers, but I am afraid there is no hope for this! I showed this bird as he was, and Mr. Hewitt awarded him a prize, looking, I presume, at his general goodness, and ignoring the blemish as possibly accidental, and I feel certain that with such a judge the honestly-shown bird with the blemish unaltered stands a better chance than with attempts at deception. It would be well if all exhibitors would feel this and act upon it, exhibiting their specimens without attempts at removing the foul spot. It is, however, certain that the usual washing and cleaning of some birds before exhibition makes it very difficult to draw a distinction between the removal of a soiled, half-broken, or injured feather which, I imagine, all of us would consider admissible, and the removal of a blemish or the painting over such a spot. I should much like to learn whether any exhibitor does consider this illegitimate; if so, it strikes me all washing must be given up, and then many of our specimens which are out-of-door livers would show up very indifferently, and white birds which are town-dwellers could never hope for distinction.

I quite agree with Mr. E. Hewitt, that it must be impossible to distinguish in order more than three or four pens in a closely-contested class with the present number of judges; it is amongst the highly commended pens that the great difficulty exists, where, in fact, one pen is as good as another, and not as our friend Pat remarks, "Yes, and a great deal better"—where "Caesar and Pompey are so very much alike." I do not

know that a "diploma" would be any easier matter. More prizes—there's the rub, and I for one would willingly say the first prize less in amount. The difference between first and second pens is really often nominal, the difference in prizes a reality to the tune of 50s., as at Birmingham this year. I am certain that an equalisation of prize money would meet with favour from exhibitors—I mean from "the million," if there be such a quantity amongst us. My old friend "E. M. B. A." is perfectly right in this. Silver cups are a very useful thing to dangle before exhibitors' eyes, but only a limited number get hold of them, and a fourth prize of the value of 10s. would do more to pay railway carriage than a dozen distant reflections of silver cups. During the past twelvemonth I have exhibited thirty-three pens of poultry, with, perhaps, a larger share of success than was my due, but anyway with decided success. Only four pens escaped honourable mention, and one of these was in a selling class. The railway carriage of these pens has amounted to £8. 7s. 6d., the entries to about the same amount. Taking this in round numbers, every pen I have exhibited has been at the cost of about 10s. Now, to those who have pockets, as a good friend of mine says, into which there is always a little stream of golden or silver hue flowing, this drain may be of slight importance, and may have many advantages and pleasures (irrespective of prizes), that make amends for the loss; but there are very many amongst us—I can answer for myself—who wish, with all our love for our hobby, that it should at least pay its way, and to this large class the smaller prizes are a great help. Diplomas, and embossed cards, and high commendations I personally value very much, and am often content with them, provided there is also a fair sprinkling of prize money. When, however, the dose is too frequently repeated I confess to feeling something like my poor old man Friday, who missed his slice of prize money, and honestly confessed "He could see no good in recommending them." This was always the word he employed. I am quite certain as regards myself, that 30s., 20s., and 10s., would induce me to enter a pen more than two prizes of £3 and £1. Of course, there is the honour and all that sort of thing, but I do not find that the railway people consider it any honour to convey my baskets. They spell honourable, if I may coin a word, "onerable," and charge for the burden accordingly.

Whilst on the subject of prizes, let me notice your remarks about the President's cup at Southampton. There it was offered to the best pen, and this gives a chance to the smallest exhibitor; but if, as you suggest, it is offered to the best collection, all the small exhibitors must be hopelessly out of the competition. If such a cup is necessary I think it most fair that the best pen should have it; at the same time I confess that personally I should prefer seeing the £10 given to increase the prizes generally, or to make new classes for other breeds not in the schedule. To make it open to the best collection would probably throw it into the hands of some local exhibitor who, without a fear of railway expenses, could flood the show. However, possibly in this view of the matter I may be singular.

Lastly, as regards the Crystal Palace Show, we southrons have now some reason to be proud—the prize schedule is greatly improved; in some of the classes it eclipses Birmingham, but "E. M. B. A.," in the concluding portion of his letter, notes a serious defect about the wire sides of the pens. I hope no such horrible affairs are to enclose the specimens. They entail great injury on the tails, and often actually loss of sickle feathers, and as in our protest on trimming we certainly meant also to object to re-tailing specimens which had lost this ornament, I trust the committee will carefully consider this detail of the show.—Y. B. A. Z.

IMPORTS.

	1868.	1869.
Eggs	253,969,040	412,175,040
Apples (bushels)	1,075,415	491,680
Potatoes (cwt.)	2,041,474	1,660,189

MUCH to the discredit of our countrymen is it that these imports are so large, and yet at the date of this publication new-laid eggs are 3d. each in London, and in Winchester and other country towns 2d. each.

SCOTTISH COLUMBIAN SOCIETY.—We commend the advertisement of the coming Show of this Society to our readers' attention. We have the prize list and the rules before us, and are well pleased with both—they are liberal and judicious.

There are twelve medals for Ponters, and eight medals for Carriers, as well as money prizes. Money prizes of 20s., 10s., and 5s. are offered for all the other well-known varieties, and an "Aoy other" class besides.

THE BIRMINGHAM CATTLE AND POULTRY SHOW.

THE preparations for the approaching great Exhibition in Bingley Hall are steadily progressing, with every prospect of a satisfactory result. The entries in all departments are 3130 against 2823 in 1869; an increase of more than 300. For the information of poultry fanciers, we have to announce that numerous entries of American varieties, including Dominique fowls and crested Turkeys, have been made, and that the birds are on their way to Birmingham from the United States. The roost department is expected to be unusually interesting. Besides the midland districts it will include specimens grown in localities so wide apart as Wales, the New Forest, and north of Aberdeen. The collection of potatoes will be very extensive, and in all probability exceedingly fine. The new American sorts will be well represented; as will also the Bovinia, the merits of which for feeding stock have for some time been attracting increased attention from agriculturists.

CARE OF BIRDS AT POULTRY SHOWS.

"SHROPSHIRE RECTOR" revives a painful recollection of the Hanley Show of this year's January. I sent, with other stock, a Mandarin drake, and had the misfortune to receive it home dead; nor can this be wondered at if, as "SHROPSHIRE RECTOR" says, "they were just set out in a row, on the floor of a desolate building, in the hampers in which they had travelled," &c. And although the bird might be in a tiny hamper in which it could barely move, the hamper was large enough for one Mandarin drake to travel in, it being quite 13 inches long and 10 inches wide, yet by no means large enough for the bird to be exhibited in.

On referring to my file of correspondence I find the secretary, Mr. J. B. Piercy, says, "I regret to have to inform you that your Mandarin drake was found dead in its pen this morning. I am at a loss to account for it, as the bird had been well fed and cared for." I think Mr. Piercy might have eaved himself the trouble of writing the latter part of this paragraph. How could a bird be well cared for when confined for three or four days in a small travelling hamper? I wish I had known the fact earlier, for I think I should have tried the case in the County Court for compensation. Exhibitors ought to know, before sending valuable specimens, whether or not pens will be provided; nor can there be any excuse for secretaries and committeemen not providing them, as the number required is known long before the birds arrive. Surely exhibitors have some claim upon secretaries and committees for considerate and humane treatment of their stock. It is enough to deter any one from exhibiting when such facts as these occur.—CHAS. BAKER, *Long Street, Atherstone.*

DEALERS, AMATEURS, AND PROFESSIONAL FANCIERS, AND PRIZE-HOLDERS.

In your number of the 10th inst. I see you have a brief notification of the formation of a new society, to be called the Croydon Columbarian Society. If it can be successfully and properly carried out, no doubt it will afford much amusement and instruction, and tend to elevate the theory and practice of breeding Pigeons. The officers appointed for the present, and it may be the last year if a certain rule be carried out to the meaning implied, are gentlemen eminently adapted for the purpose, but who do not seem to know how far the words, "denomination of dealers," extend. The offending rule in my opinion is, that all persons who come under the designation of "the denomination of dealers," are to be excluded as members and even visitors to the Society's Freemason-sort of meetings. I maintain that if this rule be adhered to, it is, strictly speaking, excluding two-thirds of the fanciers in this country, but I daresay the Society is not so ambitious as to require so large a number, still the proportion in the district supposed to be worked by the Society remains the same. Amateur fanciers only are allowed to become members; therefore professional fanciers are left out in the cold, in company with the despised dealers. I would ask, Where is the line to be drawn

between amateur fanciers, and dealers and professional fanciers? Take for instance any fancier who has a number or even a few Pigeons; does he not, as a rule, sell his surplus stock or exchange, or by selling realise a profit on a former purchase? A fancier who wishes to be successful must buy, sell, or exchange to the best of his advantage, and naturally enough he does not forget the pecuniary sense of the affair, and those coming under "the denomination of dealers" do no more than this. Most of your readers will know that several dealers are often selected as judges at the shows; therefore, the carrying out this rule is excluding men of knowledge that would benefit the fancy that the Society aims at improving. I do not suppose I should be wrong in using the words professional fanciers so long as others are styled amateurs; in any pursuit whenever one term is used the other is always applicable, as a distinction between the two classes. Therefore, a judge or a writer on Pigeons must be a professional fancier, and surely the former of the two, if not the latter, would be allowed to join; and if I am not mistaken, one, if not more, of the officers of the Croydon Columbarian Society have officiated as judges—certainly their authority on Pigeons is often quoted. Not wishing to occupy too much of your valuable space on this subject, I must say that this rule is wrongly worded, and if read and adhered to in its true sense of meaning, it will materially affect the prospects of a Society which might give valuable aid in popularising the breeding and management of Pigeons.

Now that I am writing, I hope a few remarks on another subject will not be transgressing too much on your columns. In looking over lists of awards and entries, I rarely see more than one of the names of, say, half a dozen of our greatest owners of prize-winning Pigeons exhibiting in one class, or in any way competing against others. As a strategic method of winning prizes it acts successfully to themselves, but does incalculable injury to the exchequer of a Pigeon exhibition. Having a somewhat large correspondence amongst fanciers, I have frequently found that a kind of timidity seizes upon a would-be exhibitor if he imagines or discovers that one of a certain few has entered in the class in which he intended to show. If these positive prize-winners could be persuaded to practise a little self-denial and refrain from showing their birds for, say, at least one season, then in my opinion new exhibitors would spring up, and hitherto-partly-successful exhibitors would combine together, and considerably augment the number of entries at different shows. The temporary retirement of these great owners might be turned to advantage, and when again they entered the field they would find more competitors to contend against, and any honours then won would be of more value. I would go further and say, that having won as they a set some thousands of prizes, it would be a feature of self-sacrifice that would cause the gratitude of other fanciers to name them saints and martyrs of the Pigeon world.—DAVID P. GOODING, *Colchester.*

THE NORTHERN COUNTIES COLUMBARIAN SOCIETY.

(From a Correspondent.)

THE first Exhibition of this promising Society was held at Belle Vue, Manchester, on the 19th inst. The classes were numerous and well represented, making allowance for the fact that members only were eligible to compete. The names of the prize-winners are sufficient demonstration of the quality of the stock exhibited, but the Trumpeters of Mr. Firth, which he exhibited not for competition, are worthy of a word of praise, though it be simply to say they were wonderfully good.

The Society is much indebted to Messrs. Peter Eden and William Smith, who awarded the prizes, and to the Messrs. Jennison for their general courtesy and good arrangements. Subjoined is the prize list.

CARRIERS—*Cocks*—1, J. B. Pinder, Harpurhey, Manchester. 2, H. Smith, Skipton. *Hens*—1, J. B. Pinder. *Young*—1, H. Smith.
PONTERS—*Cocks*—1, T. H. Ridpath, Outwood Hall, Cheadle (Yellow). 2, H. Smith (Yellow). *Hens*—1, T. H. Ridpath (Blue). 2, H. Smith (Yellow).
TUMBLERS—*Short-faced Kittles, Kites, and Self-colours*—1, T. H. Ridpath (Yellow). *Long-faced Mottles, Kittes, and Self-colours*—1, 2, and *hc*, R. Marshall, Lower Broughton. *Beards and Balbs*—1 and 2, T. H. Ridpath. *Long-faced Beards and Balbs*—1 and 2, W. Havercraft, Lower Broughton (Black Balbs). *hc*, T. H. Ridpath (Blue Balbs). *c*, R. Marshall (Blue Beards).
TRUMPETERS—1, 2, and *hc*, Capt. Heaton, Worsley, Manchester (Dun). *c*, W. Justice, Salford (Yellow). *Young*—1, W. Justice. 2, A. Mangnall, Lower Broughton. *c*, A. Mangnall (Dun).
JACOBINS—*Black*—1, 2, and *hc*, E. E. M. Royds, Greenhill, Rochdale. *c*, J. F. Pinder. *Any other colour*—1, T. H. Ridpath (Red). 2, E. E. M. Royds (Red). *hc*, T. H. Ridpath (Yellow). *c*, E. E. M. Royds (Red). *Young*—1 and 2, E. E. M. Royds (Black and Red). *hc* and *c*, T. H. Ridpath (Yellow and Red).
TERRITS—1 and 2, F. Marshall, Hatfield, Cheshire (Blue and Yellow). *hc*, T. H. Ridpath (Red). *c*, J. B. Pinder (Blue). *Young*—1, T. H. Ridpath (Red).
OWLS—*Foreign*—1, Capt. Heaton. 2, *hc*, and *c*, Major Crier (Southport).

English.—1, Capt. Henton (Silver), 2, W. Justice, *hc* and c, A. Mannall (Blue), Young (English).—1, W. Justice (Blue), 2, E. Slack, Manchester (Blue), *hc*, T. H. Ridpath.
 DRACOONS.—1 and 2, J. Holland, Manchester, *hc*, W. Justice, c, T. H. Ridpath (Yellow), Young.—1 and 2, J. Holland (Yellow), c, R. Marshall.
 FANTAILS.—1 and 2, T. H. Ridpath.
 ANTWERPS.—1, T. H. Ridpath, 2, R. Marshall, Young.—1 and 2, R. Anthonson, Manchester.
 ANY OTHER VARIETY.—1 and 2, E. E. M. Roysds (Black Swallows and Black Magpies).
 EXTRA STOCK.—1 and 2, Capt. Henton (Black Barb, Owls, and Yellow Barbs), 2, F. Mannall (6 Fantails, 1 White, 1 Blue, 1 Red, 1 Black, 1 Yellow, and 1 Silver), *hc*, E. E. M. Roysds (Bine Jacobins); A. Mannall (Dun Barb); R. Marshall (Antwerp), c, E. E. M. Roysds (Blue Magpies); R. Marshall.

IPSWICH POULTRY SHOW.

THIS, as a whole, was no doubt the best Show ever held in Ipswich, the number of pens showing an advance, and the quality of the bulk of the birds was unexceptionable.

Dorkings and *Spanish* formed very fine classes, and a pen of White Dorkings that were in open competition with Dorkings generally were such as would add credit to almost any show where White Dorkings have separate classes. The *Game* most certainly have never been shown so numerous and so well at Ipswich as on this occasion, the condition of the majority of the pens being extraordinarily good. A very considerable time was occupied by the judge in determining the cup-winners between the first-prize birds in the *Game* classes, which was valuable time wasted when so short a period of daylight remained, for it was afterwards proved that both pens were the property of Mr. Matthew, of Stowmarket. *Brahmas* were good, but the hen in the first-prize pen was much too light in the throat-feathers for a really first-rate bird, the cock being very good. Mr. Dowsett had all his own way in the Light *Brahmas*, with superior birds to those commonly met with. The only really well-conditioned pens in the Buff *Cochins* were the two pens belonging to Lady Gwydyr. Mr. Cattell, of Birmingham, however, exhibited a Buff hen that was by far the best *Cochin* of any kind in the Show, but her male companion was literally "nowhere," though the extraordinary merit of the hen earned a highly commended. The Partridge-coloured and the White *Cochins* were excellent, but scarcely monted out. *Hamburgs* were of the general quality throughout, the hen in the cup pen being the best barred on the tail we have seen for a long time past. The *French* fowls were well shown. A large entry of *Game Bantams* competed in a general class, Mr. Jeffries taking the cup for this variety. A very capital entry of *Ducks* added much to the interest of the Show.

Among the annual exhibitions at such meetings were a pair of Crested Carasows in magnificent plumage, and so tame as to be perfect pets; a pair of Rock Mynots, a very remarkable talking variety of bird; but unquestionably one of the most humorous of these oddities was a Green Parakeet, shown by J. Ransome, Esq. It amused bystanders by its words, "Ellen bring the baby," "Polly will kiss you," "Gentlemen fill your glasses," "three cheers for the Queen," "hip, hip, hurrah! hurrah!" "one more, hip hurrah!" in first-rate style.

In the *Canaries* the competition for the silver cup was very close. That exhibitors should not trust to the last available train in their dispatch of birds to a Show, is advice often given and continually forgotten; perhaps to simply detail facts and leave people to their own deductions might be more to the purpose. Upwards of four dozen pens were empty at the time of the adjudications: when any fresh baskets came during the afternoon by rail they were received and penned, if in classes not yet judged, to take their chances of success, but if in the classes where judging was already completed they were treated as empty pens. Many pens came in during the afternoon, some late in the evening, after the Show was closed for the night, and Mr. Crosland's *Game Bantams* came at nearly nine the next morning.

GAME.—*Black-breasted and other Birds.*—1 and *hc*, S. Matthew, Stowmarket (Black Red), 2, W. Raven, Ipswich (Brown Red), *hc*, H. C. Martin, Southorpe (Brown Red), Any other Variety.—1, Cup, and *hc*, S. Matthew (Duckwings and Piles), 2, W. Boyes, Beverley (Duckwings), c, W. Fenn, Ipswich (Duckwings); G. Knights, Ipswich (Duckwing).

DORKING.—1, J. Martin, Claines, Worcester, 2, O. E. Cresswell, Hanworth, *hc*, Rev. F. Tearle, Gazeley Vicarage, Newmarket; F. Parlett, Great Baddow; H. Lingwood, Barking, Needham Market, *hc*, F. Parlett, c, J. O. Fison, Stoke Hill, Ipswich; H. Lingwood.

SPANISH.—1 and Cup, Howard & Nichols, Peckham, 2, F. James, Peckham, *hc*, W. K. Bull, Newport Pagnell; H. Griss, Ipswich.

BRAHMAS.—*Dark.*—1, Horace Lingwood, Cretingham, Needham Market, 2, Lady Gwydyr, Stoke Park, Ipswich, *hc*, Horace Lingwood; Lady Gwydyr, c, Mrs. Kirkman, Woodbridge; C. Tindall, Ipswich. *Light.*—1 and 2, H. Dowsett, Pleasley, Chelmsford, *hc*, S. Pelgate, Ipswich.

COCHINS.—*Common or Buff.*—1, Cup, and 2, Lady Gwydyr, *hc*, J. Duffan, Ipswich; J. Cattell, Birmingham, *hc*, J. Boye, Northampton, Any other variety.—1 and 2, Horace Lingwood (Partridge), *hc*, H. H. Blitsoe, Barnswell, Oundle (White); H. Dowsett (White).

HAMBURGS.—*Pencilled.*—1 and Cup, W. K. Tiekner, Ipswich (Gold), 2, E. Clayton (Gold), *hc*, W. K. Tiekner (Gold); R. R. Parker, Ipswich (Gold); A. Coles, Long Sutton (Gold), *hc*, H. Marriott, Boston (Gold), Spangled.—1, W. K. Tiekner (Gold), 2, J. Wright, Melton Mowbray (Silver), c, J. F. Loversidge, Newark (Gold).

BANTAMS.—*Game.*—1, Cup, and 2, W. B. Jeffries, *hc*, Hon. Mrs. Paget, Hoxne, Sole; Rev. E. S. Tiddeman; W. B. Jeffries; J. Wright, *hc*, P. H. Jones, Fulham, c, W. H. Wallis, Frawlingham; P. H. Jones; H. P. Leach; J. Dove, Any other Variety.—1, C. Drake (Black), 2, Rev. F. Tearle (Black), *hc*, H. Dutton (Gold Sebrights); S. & R. Ashton (Black).

FRENCH FOWLS.—1, C. H. Smith, Esheridge-on-Trent (Chèvre-Cornu), 2, A. Taylor, Stansted, Norfolk (La Fische), *hc*, J. Boye, Northampton, Notting Hill (Chevre-Cornu); W. Tippler, Roxwell, Chelmsford (Houdans); Lady L. Charters, Attleborough (Houdans).

ANY OTHER VARIETY.—1 and Cup, H. Pickles, jun., Early (Polands), 2, Mason and Walker, Denton, Manchester (Black Hamburgs), *hc*, W. J. Woodhouse, West Wick, Lynn (Silver Polands).

SELLING CLASS.—*Pairs.*—1, H. Pickles, jun. (Polands), 2, Howard & Nichols

(Spanish), *hc*, Rev. F. Tearle (Black Bantams); F. Parlett (Dorkings); W. Dring, Faversham (Creve-Coeurs); Miss E. J. N. Hawker, Wyeliffe, Tisbury Wells (Silkies); J. Frost, Parham (Dorkings); Rev. E. S. Tiddeman, Childerich Vicarage (Game Bantams); Lady L. Charters (Houdans), c, Rev. F. Tearle (White Bantams); Rev. E. S. Tiddeman (Brahmas), *hc*, T. J. Salsmarsh, Chelmsford (Partridge Cochins), 2, W. B. Jeffries, Ipswich (Black Red Game Bantam), *hc*, Howard & Nichols (Spanish); W. B. Jeffries (Black Red Game Bantam); T. W. Watling, Ipswich (White Cochins), *hc*, J. Frost (Dorkings); W. Rayner (Duckwing Game); Lady Gwydyr; S. H. Stott (Dorkings); W. K. Tiekner (Golden-pencilled Hamburg).

DUCKS.—*Winn.*—1, F. Parlett, 2, Rev. G. Gilbert, *hc*, H. Dowsett; S. H. Stott, Aylesbury.—1 and 2, Lady Gwydyr, Any other Variety.—1, T. Roper, Parham (Carolina), 2, C. N. Baker, Chelsea (Carolina), *hc*, S. & R. Ashton, Mottram.

PIGEONS.
CARRIERS.—1 and *hc*, W. Massey, 2, C. H. Clarke, Nottingham, *hc*, C. H. Clarke; W. Massey (2), c, H. Yardley, Birmingham.

BARBS.—1, H. Yardley, 2, P. H. Jones, *hc*, W. Massey, Spalding.
POUTERS.—1, P. H. Jones, 2, H. Yardley, *hc*, J. A. Ransome, Ipswich.
TURTLES.—1, J. H. Brad, Cambridge, 2, P. H. Jones, *hc*, W. J. Woodhouse.
FANTAILS.—1, J. F. Loversidge, 2, P. H. Jones, *hc*, W. Massey; H. Yardley.
TRUMPETERS.—1, P. H. Jones, 2, E. Sheerman, Chelmsford, *hc*, E. M. L. Cocksedge.

TURBITS.—1, O. E. Cresswell, 2, H. Yardley.
 ANY OTHER VARIETY.—1, J. A. Ransome (Icol), 2, H. T. Frere, Burton Rectory, Doss (Yellow Dracoons), *hc*, H. Lyon, Ipswich (Carriers); W. Bird, Ipswich (Blue Owls); J. A. Ransome (Silver Antweps), *hc*, C. T. Higgins, Northampton (Blue Owls); H. Green, Ipswich (Blue Owls and Black Magpies); J. A. Ransome (Silver and Scarlet Bantam).

SELLING CLASS.—1, Sheerman (Trumpeter), 2, W. Bird (Blue Owls), *hc*, H. Yardley; T. Roper (Barbs), *hc*, H. Lyon (Silver Dun Carrier) (2); H. Green (Jacobins); A. Coles (Carriers); H. T. Frere (Yellow Beards), c, H. F. Nalder; W. Massey (Barbs).

CANARIES.
Yellow-Clear.—1 and 2, Moore & Wynne, Northampton, *hc*, T. Mann, Cambridge New Road; E. Loose, T. Fenn, c, T. Fenn, Ipswich (2); G. J. Barnesby, Derby (2), Mottled.—1 and 2, Moore & Wynne, *hc*, R. Mackley; G. J. Barnesby; T. Mann; T. Fenn; F. Gayton, c, G. J. Barnesby; T. Mann; Cockle & Watson, Mottled Crested.—1, 2, and *hc*, T. Fenn, c, G. Gayton; Moore & Wynne.
Nealy.—*Clear.*—1 and 2, Moore & Wynne, *hc*, R. Mackley, Norwich (2); G. J. Barnesby, c, T. Fenn; G. J. Barnesby (2); Cockle & Watson, Tennington St. John, Mottled.—1 and 2, Moore & Wynne, *hc*, G. J. Barnesby; T. Fenn; G. Gayton, c, R. Mackley, Mottled Crested.—1, R. Mackley, 2, T. Fenn, *hc*, R. Mackley; G. J. Barnesby; T. Fenn, c, H. Green.
LIZARD.—1, R. Mackley, 2, G. J. Barnesby, *hc*, T. Fenn; R. Mackley; Cockle & Watson, c, G. J. Barnesby; T. Fenn.
GOLDFINCH MULE.—1 and c, R. Mackley, 2, and *hc*, G. J. Barnesby.
 ANY OTHER VARIETY.—1, T. Mann (London Fancy Canary), 2, G. J. Barnesby, *hc*, R. Mackley (Linnit Mule); G. J. Barnesby; Cockle & Watson (Cinnamon), c, G. J. Barnesby; T. Fenn; G. Gayton (Cinnamon Crested).
SELLING CLASS.—1 and 2, T. Fenn, *hc*, T. Fenn; K. Loose, c, R. Loose, Stoke, Ipswich.

Mr. Edward Hewitt, of Birmingham, judged the Fowls and Pigeons; and Mr. J. Willmore, of London, the Canaries and Singing Birds.

A GREAT mistake was made by requiring all specimens to be in the Show on November 16th, before twelve o'clock. Now the Show is to take place on Thursday and Friday, the 17th and 18th, so that we at a distance of about five hundred miles have to send our birds off on the 15th to be there in time. This could easily have been avoided if 10 P.M. instead of 12 A.M. had been the hour named, so that the birds could have gone in one day's journey. I have entered for the above Show, but had I seen it sooner I most certainly should not have wasted my entry money. The birds shall remain at home, as I consider it a cruelty to send birds to stay all night in hampers, besides being without food and water. I write this merely as a caution to others situated like myself to carefully examine the rules before they send their entrance money.—GAME BANTAM.

NEWCASTLE-UPON-TYNE ORNITHOLOGICAL SOCIETY'S SHOW.

If thirty-six classes of Pigeons, with prizes of 20s. and 10s., four cups, and one gold medal will yield 443 entries, how many entries will twenty-three classes of Canaries yield, with a prize list of 10s. and 5s., four silver medals, and one copper kettle? Answer, 209. A comprehensive schedule with a liberal prize scale, is another name for a large show. Each class has its own particular admirers, and if a prize list be framed to suit all classes of exhibitors, support will come from where least anticipated, provided always there be sufficient inducement to compete. Bronze medals, laurel wreaths, and purely honorary prizes are most excellent in their way; but there is a medal bearing Her Majesty's profile which has stronger attractions. It helps to pay entry fees and railway expenses. There is something of which it is predicated in roundhand in our childhood's copybook, that it is its own reward; but poultry, Pigeon, and cage bird exhibitionising, has become so much a business, that only a favoured few can afford to compete *con amore*.

I have been among the upper walks of life—among the Pigeons. They must hold a higher place than Canaries in the show world, for they seem to me to represent a larger amount of real capital, and does not the title page of the Journal say, "Pigeons, Aviary Birds, &c.?" Don't you think it is almost that stereotyped little centrepiece were altered, and that "Canaries" became the first word of a line? Would it not

read better, "Pigeons, 'WILTSHIRE RECTOR,'" and then give Canaries and Aviary Birds a line to themselves? A little spacing-out, and a piece of "furniture" here and there would do it without destroying the symmetry of the page. Don't you think so?

Yes, I was among the Pigeons at Newcastle, and Mr. Fulton kindly went round and did all he could to lead me astray, and tempt me into his fancy. He explained the distinctive points of the different varieties in a most interesting manner; and with such apparently faultless standards of perfection before us to illustrate his lecture, he had no difficulty in pointing out what constituted a first-class and what a second-class bird. But I am afraid I was not a very apt pupil, though I can recognise a Pouter, a balloon-looking gentleman on a half brick, a Barb, a Dragoon (and you must not try to deceive me with a half-bred Carrier after Mr. Fulton's lesson), a Fantail, a Carrier, and a Trumpeter. The general appearance of the Show was very imposing, the arrangement perfect; and I am sure there was but one opinion that Mr. Blenkinsop, the Honorary Secretary, and his coadjutors are men well up in their business, and fit custodians of the reputation of Newcastle as regards the exhibition of Pigeons and cage birds. The Corn Exchange in which the Show was held covers an immense area, but the lighted gas kept it at a comfortable temperature, and not even the most delicate specimens experienced any inconvenience.

In the Canaries Mr. Rutter took all the Belgian prizes, the only specimen approximating to the quality of his being No. 452 (J. N. Harrison), a remarkably fine bird, showing true Belgian contour and "position." The silver medal for the best bird in the Belgian classes was won by No. 453, a yellow hen. Norwich were strong, Moore & Wynne taking the lion's share of prizes, and Mr. Mills the silver medal with No. 495, Evenly-marked Jonque, exhibited in faultless trim. The Glasgow Dove, the bird of Scotland, formed a prominent feature of the Show, Mr. Clark, of Newcastle, winning the medal with a remarkably neat bird. In Goldfinch Males, Mr. Young's well-known buff bird won the silver medal easily, disposing of all comers, Jonque and Mealy, including divers birds "clipped and trimmed." The Judge's opinion was duly handed in, but as I observed no intimation of the same affixed to the cages, I do not feel in a position, as reporter of a show, to mention names. I have elsewhere expressed my opinion as to what should be done in such cases, and what are the relative duties of judge and committee.

It was a cruel thing to ask any judges to decide between Mr. Spence's Brown Linnets and Mr. Stansfield's Bullfinch and Goldfinch Male. Perhaps the equal of each never was seen. Mr. Irons took the medal for the best birds among the Cinnamon, Greens, and Any variety with one of his fine Jonques, and Mr. Baxter, of Newcastle, was able to add a copper kettle to his stock of kitchen utensils through the aid of a good Goldfinch; and a fine Linnets won the silver medal for Mr. Briggs, also of "canny Newcastle." Among the Foreign Birds, a Mocking Bird, shown by Captain J. F. B. Dodds in splendid plumage, occupied much attention, and took first honours.

Judging over, I with Mr. Corker, of Croydon, one of the Judges of Pigeons; Mr. Horner, of Leeds; and Mr. Firth, of Dewsbury, both well-known successful exhibitors of Pigeons, were the guests of W. B. Van Haansbergen, Esq., who taxed the dining resources of the Union Club on our behalf in a way which they and I will not soon forget. We had already lunched with the Secretary, but hospitality appears to be one of the "rules and regulations" of the Newcastle-on-Tyne Ornithological Association.—W. A. BLAKSTON.

THERE were nearly five hundred pens of Pigeons, and of a quality never before seen at Newcastle; the liberal prize list and indefatigable exertions of the Honorary Secretary, Mr. H. O. Blenkinsop, having brought about this desirable result. The Corn Exchange in which the Exhibition was held is, perhaps, unequalled for the purpose, being convenient, capable of accommodating several hundreds of visitors, with ample room for the pens, which were all on one level, and on this occasion the temperature was well regulated by the use of numerous gas jets. Not a single mishap occurred either to the Pigeons or Canaries, and too much praise cannot be given to the attendants, who looked well after the feeding, &c., of the birds.

In Carriers, Messrs. Fulton, Massey, and Horner monopolised the prizes. Mr. Massey's birds took our fancy very much; their fresh, healthy, genuine appearance, combined with properties of head, beak, eye, and figure, render it more than probable that they may turn the

tables on their more aged and better-furnished competitors at some future shows.

In Pouters, the most noticeable birds were Mr. Fulton's Yellow, Blue, and Black cocks, and Yellow and Blue hens, all of which were excellent. We must not omit to mention the second-prize Blue cock and hen shown by local exhibitors, Messrs. Thomson & Simpson, who well merited the position they attained. The White Pouters were a fine lot, several pens being worthy of a prize.

Almond Tumblers were a show of themselves—nineteen pens, and at least fourteen very good. Mr. Blenkinsop's pair were deservedly first. The cock in this pen and that in Mr. Van's pen were the two best head-and-beak birds in the Show. Messrs. Ford, Horner, and Adams, also showed very good birds. Mr. Ford won with beautiful Black Mottles in the "other" Tumbler class. Yellow, whole feathers, were second. No other pen was good.

In the Barbs Mr. J. Firth was first with a magnificent pair of Blacks in the class of that colour. The cup in this section was awarded to this pen, the cock being unquestionably one of the very best birds of the day. Mr. Firth was also first with a good pair of young Yellow Barbs. Mr. Fielding showed a good pair of Yellows, but they were much out of condition, and Mr. Fulton had a pretty pair of Whites, the best we have seen for some time.

Foreign Owls were a good class. English Owls had a large entry, but many pens were obviously passed over.

Of Jacobins there were twenty-three entries, some of the best birds were in deep moult. The winners were good Reds. In this class several pens contained an excellent and an indifferent bird; mostly the Yellows were too coarse, excepting those of Mr. Van Haansbergen and Mr. Fulton, and both their pens were out of condition. For Jacobins of any other colour Mr. Van Haansbergen took both prizes, his Whites being the best we ever saw, his fine pair of Blacks also taking the sectional cup.

Fantails were a splendid class; five or six pens seemed almost equally good, and each worthy of a first prize. It would be very desirable to give this variety a little more room.

Trumpeters were a good class; Mr. Horner's birds the best in rose and crest, but deficient in feet and marking. Mr. J. Firth's pair took first, the cock a grand bird; Mr. Van Haansbergen was second with a splendidly bodied and rosed pair, but too light in mottle. Whites were first in the "Any other" Trumpeter class; Blacks second, both good. A novelty was shown in a pair of Reds, good in properties, but sooty in colour.

The Thrift classes contained good birds of every colour. The same may be said of the Magpies.

Nuns were a good class. Yellows, Duns, and Blacks were shown. Chequered Dragons were first in their class, Yellows second; good Blues, Yellows, and Whites also competed.

Antwerps were an average collection.

Common Tumblers were not particularly noticeable, excepting that many pens were evidently left out on account of not answering the requirements of the schedule.

The prizes for Any other variety were won by good Letz. Good Swiss were shown, and pigmy Austrian Pouters; also a pair of white birds, which looked something like a cross between a Runt and a Fantail, runtishly-made birds with short bob tails.

In the Selling class many pens were claimed.

The following is the prize list:—

CARRIERS.—Black.—Cock.—1, E. Horner, Harwood, Leeds. 2, W. Massey Spalding, *hec*, R. Fulton, Deptford, *hec*, R. Fulton; T. Colley, Walsley, Sheffield; G. J. Taylor, Earlown, Ruddersfield, *c*, F. Smith, Selley Oak, Birmingham. Hen.—1 and Cup, R. Fulton. 2, G. J. Taylor, *hec*, F. Smith, *hec*, R. Fulton; E. Horner, *c*, E. Horner. *Dun*, or *any other colour* except Black.—Cock.—1 and *c*, R. Fulton. 2, W. Massey, *hec*, G. J. Taylor. Hen.—1, J. Thompson, Bingley. 2 and *hec*, R. Fulton, *hec*, T. Colley.
POUTERS.—Blue or Black.—Cock.—1, Cup, and *hec*, R. Fulton (Black and Blue). 2, Thompson & Simpson, Widenow, Newcastle. *hec*, R. Fulton (Blue) and A. Wintour, Edinburgh (Blue) (2); E. Horner. Hen.—1 and *hec*, R. Fulton (Black). 2, Thompson & Simpson (Blue). *hec*, R. Fulton (Black); E. Horner, *c*, E. Horner. Red or Yellow.—Cock.—1 and *hec*, R. Fulton (Red and Yellow). 2, J. Walker, Newark (Red). *c*, A. Wright, Eden Side, Edinburgh (Red); W. Harvey, Sheffield (Yellow); H. Brown, Walsley, Sheffield (Red); J. Bell, Newcastle (Red). Hen.—1 and 2, R. Fulton (Yellow). *hec*, H. Brown, *hec*, A. Wright (Red); C. Vaux, F. T. Boldon, Sunderland. White.—Cock.—1, W. Harvey. 2, E. Horner, *hec*, R. Fulton (2); J. Morrison, Morning Side, Edinburgh (2). Hen.—1, E. Fulton. 2, W. Harvey; H. Cuckton, Middlesbrough; R. Fulton; J. Hawley, Bingley. *Any other Colour*.—Cock.—1, W. Moon, Edinburgh (Chequer). 2, H. Brown. *hec*, W. B. Van Haansbergen, Newcastle (Ash). *hec*, R. Fulton (Mealy). Hen.—1, J. Morrison (Chequer). 2, W. Moon, Edinburgh (Splash).
TUMBLERS.—Short-faced.—Almond.—1 and Medal, W. R. & H. O. Blenkinsop, Newcastle. 2, J. Ford, London. *hec*, E. Horner, *hec*, E. T. Dew, Weston-super-Mare; C. Vaux; H. Adams, Beverley. *Any other Colour*.—1, J. Ford (Black Mottles). 2, G. J. Taylor, *hec*, W. R. & H. O. Blenkinsop.
BARS.—Black.—1 and Cup, J. Firth, Dewsbury. 2 and *c*, R. Fulton, *hec*, R. Fulton; F. Horner. *Any other colour* except Black.—1, J. Firth. 2, R. Fulton, *hec*, J. Fielding, jun., Rochdale; W. Massey (Red); C. Vaux; J. King, Newcastle (Red).
FOLDS (Foreign).—1, R. Fulton, Fulham. 2, W. R. & H. O. Blenkinsop. *hec*, J. Fielding, jun.; P. H. Jones.
JACOBS.—Red or Yellow.—1, E. Horner. 2, N. F. Nalder, Croydon (Red), *hec*, T. C. & E. Newbitt, Epworth; R. Fulton; W. B. Van Haansbergen (Red and Yellow); W. Harvey. *Any other Colour*.—1, Cup, 2 and *hec*, W. B. Van Haansbergen (Black and White).
FANTAILS.—White.—1, R. Fulton. 2, J. F. Lovelandside, Newark-on-Trent, *hec*, E. Lovelandside; J. Walker, T. Rule, Furlham; W. R. Park, Melrose; W. Henry, Aberdeen. *Any other Colour*.—1, P. H. Jones. 2, H. Yardley.
TRUMPETERS.—Mottled.—1, J. Firth. 2, W. B. Van Haansbergen. *hec*, W. Harvey. *Any other Colour*.—1, W. H. C. Oates, Desterbore, Newark (White). 2, T. Rule, *hec*, J. Firth; W. R. & H. O. Blenkinsop.
THRIFTS.—Red or Yellow.—1, P. H. Jones. 2, J. Fielding, jun. (Red). Blue, or *any other colour*.—1, W. R. & H. O. Blenkinsop. 2, T. Rule, *hec*, E. T. Dew (Silver).

MAGPIES.—1, E. Horner. 2, P. H. Jones. *hc*, E. Horner; Miss E. Beldon, Goutaker, Pingley.
 SIBS.—1, P. H. Jones. 2, F. Graham, Birkenhead. *hc*, F. Graham; E. T. Dew.
 OWLS (English).—1, J. King. 2, A. Jackson, Heaton, Bolton-le-Moors. *hc*, J. Wilson, Darlington; E. Horner; W. Goddard, Earleton.
 DRAGONS.—1, S. N. Challoner, Newcastle. 2, A. Ashton, Parkfield, Middleton. *hc*, J. Ford; J. Watts, King's Heath, Birmingham; F. Graham (2); J. Stanley, Salford.
 ANTS.—1, J. A. Collinson. 2, E. Horner. *hc*, J. Hawley; J. Candale, Carlisle.
 TUMBLERS (Common).—1, J. Dye, Newcastle. 2, P. Stephenson, *Bald Pates*.—1, R. Grey, Gateshead. 2, R. & J. F. Baldwin, Newcastle. *Breeds*.—1, J. Dye. 2, Miss E. Beldon. *Any other Colour*.—1, W. Harvey (Stottles). 2, J. Hawley (Red Mottles). *hc*, J. A. Collinson (Red).
 ANY OTHER VARIETY.—1, W. R. Park (Lutz). 2, H. Yardley. *hc*, J. Watts; E. Horner; W. Harvey (Poreclain); W. Goddard (Black Austrian Pointers).
 SELLING CLASS.—1, J. Fairley, Edinburgh. 2, Miss E. Beldon. 3, S. N. Challoner. *hc*, N. P. Noller (Jacobins); J. Hawley; W. B. Van Haansbergen; E. Horner; W. R. & H. O. Blenkinsop; C. Anton, Jun., York.

CANARIES.

BELGIANS.—*Clear Yellow*.—1, 2, and Medal. J. Ratter, Bishopwearmouth. *hc*, J. N. Harrison, Belper. *c*, J. Baxter, Newcastle. *Clear Buff*.—1 and 2, J. Ratter. *Ticked or Variegated*.—1 and 2, J. Ratter. *c*, T. Bennett, Seaton Burn Colliery, Northumberland.
 NOAVICH.—*Clear Yellow*.—1 and 2, Moore & Wynne, Northampton. *hc*, R. Hawman. *c*, J. Briggs, Newcastle. *Clear Buff*.—1 and 2, Moore & Wynne. *Marked or Variegated*.—1 and Medal, E. Mills, Sunderland. 2 and *hc*, Moore and Wynne. *hc*, R. Hawman. *Crested Yellow or Yellow Marked*.—1, R. Hawman. 2, Moore & Wynne. *hc*, T. Irons, Northampton. *hc*, G. C. Brown, Newcastle. *c*, J. Rutter. *Crested Buff or Buff Marked*.—1, J. Young. 2 and *hc*, Moore & Wynne. *c*, J. Ratter.
 GLASSGOW DONS.—*Clear Yellow*.—1 and Medal, W. Clark, Newcastle. 2, R. Ruddick. *c*, J. Gaskins. *Clear Buff*.—1 and *hc*, (2) W. Clark. 2, J. Langhead, Kilmarnock. *Marked or Variegated*.—1, J. Baxter. 2, C. Smith. *hc*, W. Clark.
 GOLDFINCH MULES.—*Yellow*.—1, Stephens & Burton. 2 and *c*, E. Stansfield. *Buff*.—1 and Medal, J. Young, Monkwearmouth. 2 and *hc*, J. Baxter. *c*, R. Pearson, Newcastle. *Marked or Tipped*.—1, Stephens & Burton. 2, Moore & Wynne. *hc*, J. Carter, Newcastle. *c*, J. T. Dobson; J. Young.
 MULE (Any other variety).—1, E. Stansfield. 2, J. Spence, New Hendon, Sunderland. *hc*, J. Baxter. *hc*, J. Young. *c*, J. Baxter; G. Atkinson, Gateshead.
 CINNAMON.—*Jonque*.—1 and Medal, T. Irons. 2, J. Spence. *hc*, T. Irons. 3, T. Jones, Northampton (2). *c*, J. Wilson, Newcastle; E. Mills. *Buff*.—1 and *hc*, W. Gumble, Northampton. 2, T. Irons. *hc*, J. Young. 3, T. Jones. *c*, J. Spence; E. Mills. *Marked or Tipped*.—1, S. Tomes. 2, R. Hawman, Middleburgh. *hc*, Stephens & Burton. *hc*, Moore & Wynne. *c*, J. Young; S. Tomes.
 GREEN.—1, Stephens & Burton. 2, G. Atkinson. *hc*, J. & T. Dohson, Newcastle. 1, L. Billcliffe, Newcastle. *hc*, J. Eland, Newcastle; J. King. *c*, J. Carter; W. T. Mein, Newcastle.
 ANY OTHER VARIETY OF CAGE BIRD.—1, E. Mills (Golden-spangled Lizard). 2, J. N. Harrison. *c*, P. Stephenson; J. Baxter; E. Stansfield, Bradford.
 GOLDFINCH.—1, Baxter. 2, Stephens & Burton. *hc*, J. Harrison. *c*, W. Richardson, South Shields.
 LINNET (Brown).—1, J. Caprig, Newcastle. 2, J. Baxter. *hc*, J. N. Harrison.
 FOREIGN BIRDS.—1, Capt. J. F. B. Dods, Newcastle. 2, G. A. Tate, North Shields. *hc*, J. Atkinson. *c*, T. J. Pickett, Newcastle (Bishop); M. Brown, Gateshead (Austrian Parrots); P. Guthrie; W. B. Van Haansbergen; W. R. & H. O. Blenkinsop.

JUDGES.—For Pigeons: Mr. Corker, Croydon, and Mr. T. J. Charlton, Trafalgar Street, Bradford. Canaries: Mr. W. A. Blakston, Sanderland, and Mr. T. Lawrey, Gateshead.

JOHNSTONE POULTRY AND PIGEON SOCIETY.

THE third annual Exhibition and competition of poultry and Pigeons under the auspices of this Society, took place on Saturday the 12th inst., in the New Town Hall, Johnstone, Renfrewshire. The first glance round the well-filled Hall assured us that our trip to this busy town was to be amply repaid. Some grand specimens of birds in both departments at once attracted our attention, and there was only nine empty pens, owing to birds not being forwarded.

In the poultry department, Black Spanish were a small but good class; the protracted dryness of the season having retarded the moult, few birds in the west of Scotland of this class were ready for exhibition. The first and second-prize pens were particularly fine. Game were well represented, many fine and powerful birds being present. Among the *Dorkings* stood some noble massive-looking birds. But the great feature of this department was the *Humberghs*—Silver, Golden-pencilled, and Spangled. There was a fair turn-out of the old *Scottish Geys*, homely, solid, useful-looking birds; also very pretty class of *Game Bantams*, quite a show of themselves. Bantams, "Any other variety," included most of the colours bred in this class, the first prize being awarded to Mr. Yardley, Birmingham, for a pair of very handsome Golden Sebrights. Ducks, both Aylesbury and Rouen, were very fine. This department was so well judged that the awards, which we give below, speak for themselves.

The poultry were placed in large roomy pens; sides sheet iron, front, top, and back wire, giving at once plenty of light and air.

The Pigeon department surpassed last year's entries at this Show, partly in numbers, but particularly in quality. We had not crossed the doorway of the main entrance to the Hall before we were satisfied of this. A finer line of Pouters are seldom seen out of a city show than stood in this Hall. The Blues in particular were fine, many of them very valuable birds, showing not only great size and length of limb and feather, but also perfect marking. We thought the first and second prizes belonging to the same exhibitor might have been safely reversed, though, without doubt, they were very close. The best Blue Rock in the Show stood in pen 259, entered by Mr. James Butler, Glasgow, but, unfortunately, he was wretchedly matched and could have no chance. The Blacks were hardly up to the Blues in some points, particularly as to colour and length of limb. Among the "Any other colour" were many very handsomely formed and large birds. Carriers formed a splendid class; the first and second-prize birds

were very fine, but rather broad in the head. We admired the third-prize pen (young), they possessed that style and form so ably represented in Mr. Wolstenholme's celebrated portrait of this bird. Of Short-faced Tumblers there was the best class ever shown by this Society, comprising Almonds, Mottles, and Kites. Barbs were a very fine class; the first-prize pen were wonderful birds, carrying also the extra prize. Fantails formed a large class, containing many birds in most respects perfect; the true Indian type was displayed—the perfect tail, but above all, the motion. Mr. Reid, Lochwinnoch, pen No. 254, showed a cock, extra fine, but badly matched; Mr. Murdoch, Johnstone, a very fine hen, badly matched; and Mr. Sharp a pair of Black Saddles—cock perfect, but rather large. Jacobins were an extra good class; as Jacobins are generally to be seen, there seems to be too much regard paid to the colour of eye in this bird; the small, thin, swallow-shaped bird is now seldom met with. Jacobins do not seem to improve much. Common Tumblers were a pretty class, comprising Red and Black Mottles, Red and Black Baldheads, Black and Blue Beards, &c. In the "Other distinct variety" class, the first and extra prizes were carried off by a pair of those sweet little Pigeons, African Owls.

The Pigeon department was judged with great care and skill; it would have been a difficult matter for anyone to have detected a flaw.

The whole arrangements of this Show were managed with great taste and judgment, and reflect no small credit on the Committee. The weather was very fine, and the visitors numerous, rather too numerous as the day advanced.

SPANISH.—1, J. Gray, Airdrie. 2, W. Barr, Avon Braes, Hamilton. 3, J. Crawford, Scotch, Beith. *hc* and *c*, A. Robertson, Kilmarnock.

DORKINGS.—1 and Timepiece, J. Gray. 2, H. Pickles, Jun., Early, York-Lire 3, J. Malcolm, Langton, Falkirk. *hc*, D. Gellatly, Meikle. *c*, A. Grant, Jun., Kilbarclach.

GAME.—*Black or Brown Reds*.—1, J. Waddell, Airdrie Hill, Airdrie. 2, R. Arbnuckle, Parkhead, Glasgow. 3, J. Gray. *hc*, J. Gow, Kilbarclach. *c*, J. Sueddon, Linwood. *Any other Colour*.—1, J. Gray. 2, *hc* and *c*, R. Andrew, Grahamstown, Barhead. 3, D. Hurley.

HAMBURGERS.—*Golden-spangled*.—1, H. L. Horne, Whiterigg. 2, R. Tyson, Longlow, Carlisle. 3, J. Mair, Kilmarnock. *hc*, J. Sloan, Glasgow. *c*, J. Jardine, Kilmarnock. *Silver-spangled*.—1, J. Bruce, Barhead. 2, D. Gilmore, Kilmarnock. 3, A. Glen, Paisley. *hc*, J. Wilson. *c*, A. Grant, Glemtyan Mill. *Golden-pencilled*.—1 and Timepiece, S. & R. Ashton, Mottram. 2, A. Wallace, Paisley. 3, G. Calthness, Carnoustie. *hc*, W. Nelson, Johnstone. *c*, W. Bachop, Paisley. *Silver-pencilled*.—1, W. Bachop. 2, J. Sharp. 3 and *c*, H. Ayrle. *hc*, H. Colligan, M.D., Paisley.

BRAMA POOTRA or COCHIN-CHINA.—1, J. Pollock, Bushy. 2, A. Robertson, Kilmarnock. 3, A. Carswell, Turbith. *hc*, J. Carswell, Neilston. *c*, D. Gellatly, Meikle.

SCOTCH GREYS.—1 and 3, A. Grant. 2, R. Smith, Holmes. *hc*, J. Meiklem. *c*, J. Sueddon, Paisley.

BANTAMS.—*Game*.—1, J. Gray. 2 and Timepiece, J. Gow. 3, D. Johnstone, Jun., Dalry. *hc*, T. C. & E. Newbitt, Epworth. *c*, J. Sharp. *Any other Variety*.—1, H. Yardley, Birmingham. 2, A. Mitchell (Black). 3 and *c*, H. L. Horne, Whiterigg (White and Black). *hc*, J. G. Orr, Beith (Silver-faced).

DUCK.—1, J. Pollock, Bushy. 2, A. Robertson, Kilmarnock. *Any other Variety*.—1, Timepiece and 2, A. Robertson. 3, S. & R. Ashton. *hc*, J. Meiklem. *c*, S. H. Stott, Quarry Hill, Rochdale.

SELLING CLASS.—1, J. Waddell. 2, T. Jackson, Elderslie. 3, B. M. Knox. *hc*, J. Aitken, Johnstone (Silver-spangled Hamburgs). *c*, J. Gow. *Hens* (Any Breed).—1, J. Campbell, Johnstone (Black Red Game). 2, H. Pickles, Jun. 3, J. Waddell (Brown Red Game). *hc*, W. Bachop. *c*, D. Gellatly (Dorkings).

PIGEONS.

POUTERS.—*Blue*.—1, 2, and Timepiece, J. Miller, Glasgow. 3, J. Mitchell, Glasgow. *hc*, J. Sharp. *c*, W. Nelson. *Black*.—1, Miller, Glasgow. 2, W. Nelson. 3, J. Mitchell. *hc*, J. Sharp. *c*, J. Mitchell. *Any other Colour*.—1, J. Miller. 2, J. Sharp. 3, J. Mitchell. *hc*, J. Muir, Kilmarnock. *c*, W. Nelson.

CARRIERS.—1 and 2, J. Miller. 3, G. White. *hc*, H. Yardley. *c*, J. & W. Towerson, Egremont.

TUMBLERS.—*Short-faced*.—1 and 2, J. Miller. 2, J. Paton, Rigg, Stewarton. *hc*, J. Fielding, Jun., Rochdale. *c*, J. Sharp. *Common*.—1, W. Reid, Lochwinnoch. 2, J. Mackay, Glasgow. 3, J. Aitken. *hc*, J. A. Collinson, Halifax. *c*, W. Webster, Birchenhead.

BARBS.—1 and Timepiece, M. Miller, Glasgow. 2, J. Miller, Glasgow. 3, H. Yardley. *hc*, J. Fielding, Jun. *c*, G. White, Paisley.

FANTAILS.—1, J. Galt. 2 and 3, J. Sharp. *hc*, C. Murdoch, Johnstone. *c*, H. Yardley.

JACOBINS.—1, G. White. 2 and *hc*, J. Sharp. 3 and *c*, J. & W. Towerson. *COMMON*.—1, W. G. Kerr, Glenclart, Dalry. 2, 3, and *hc*, J. Sueddon, Birse Knowe, Beith. *c*, J. Galt, Kirribride.

ANY OTHER VARIETY.—1, 2, and Timepiece, J. Sharp. 3, J. Fielding, Jun. *hc*, H. Yardley. *c*, G. White, Paisley (Trumpeters).

SELLING CLASS.—1, J. Sharp. 2, T. C. & E. Newbitt. 3, G. White. *hc*, R. Blair, Johnstone. *c*, W. Genuell, Johnstone.

JUDGES.—Poultry: Mr. T. Williamson, Grangemouth; Mr. A. Paterson, Airdrie; Mr. W. Creelman, Kilmarnock; and Mr. J. Green, Glasgow. Pigeons: Mr. J. Wallace, Glasgow; and Mr. M. Stewart, Glasgow.

DRONES IN NOVEMBER.

Much as they may differ in some of their theories and conclusions respecting the economy of their favourite insect, most, if not all, bee authorities, I believe, agree in asserting that all drones are destroyed or driven forth early in the autumn of each year, frequently as soon as the middle of June. The only exception I see noticed is when a Live becomes deprived of its queen in the drone season, when the instinct of the bees demands that the drones shall, in most cases, not be expelled, but tolerated and fed as long as they will naturally exist. Having read many of the works of these bee authorities with perhaps less profit than might be expected, and fully accepted this massacre of the drones at all events as an un-

doubted fact, I was somewhat surprised to learn that drones were heard flying one day last week (the 3rd inst.), in the front of two of our stocks of black bees. These were two very strong colonies, which were eagerly taking advantage of every instant of the beautiful week which here ushered in the opening of November. Early and late they poured forth in one continuous stream, the return of which was bees laden heavily with bright yellow farina or with honey. I concluded there must be some mistake, and gave the matter no further consideration, until, on coming to open the two hives a day or so later, drones were undoubtedly in both of them.

This being to me an uncommon phenomenon, I should be glad to know if drones have been observed by others so late in the year and under similar circumstances; for I should say that the hives, when opened, showed themselves to be chokelaf of bees, with sheet after sheet of brood in all stages, a fine store of honey, apparently daily increasing, and active and laying queens. None of the conditions are here apparent that would induce a colony to keep its drones alive, and the circumstance presents to my mind one of those cases where the instinct of bees goes beyond human comprehension.—I-DRONE.

PERMANGANATE OF POTASH AS A CURE FOR FOUL BROOD.

THE disease called foul brood has long ago been banished from every stock in what I call my apiary; but that I might be able to resuscitate the plague whenever occasion demanded, I carefully laid aside a few tainted combs in a place to which bees could not possibly gain access. With these combs I inoculated a small Woodbury box in the autumn of 1869, for the purpose of observing what influence muriatic acid would exert upon collapsed larvae. The acid when poured into foul cells sensibly checked the progress of disease, but it failed to restore health.

Whilst meditating upon other agents that might be employed, a request was made to me to try a remedy which a gentleman in London had found successful in curing two of his foul stocks. To this request I at once responded, and towards the middle of December I was favoured with a small packet containing crystals, which, when used in solution, were said to be a very powerful "disinfectant and deodoriser." The instructions given were to the effect that on the infected bees being driven into an empty skep they were to be allowed a tablespoonful of the solution in a pint of syrup, and not only to be fed with it, but to be rolled in it, so that they might be literally wetted with it, both within and without. Then, after a quarantine of about twenty-four hours, the bees so treated were to be united to a healthy stock, or turned amongst healthy bees. The value of the discovery, it thus appeared, was limited to the purifying of infected bees, and as I believed that quarantine *per se* could effect this, I inquired of the author whether his prescription would not also deodorise and disinfect tainted combs and boxes. To this he replied, "I cannot be sure that the disinfectant I sent you will cure the tainted combs, not having tried it with them; but I am quite sanguine about it if care be taken, for the solution will positively disinfect any and every thing in a sanitary sense."

The solution, being permanganate of potash, was not to be despised, and I proceeded with pleasure to the preparation of hives for testing its virtue. In due course three small Woodbury boxes were contaminated with disease, and about the beginning of August last one was virulently foul, all of its combs being well filled with brood. To allow the healthy progeny to mature, and prevent any more eggs being laid, as well as to facilitate future manipulation, I removed the queen, and left the hive unopened for the next two weeks or longer. On the 29th of the month I made an inspection, and finding that the healthy brood had nearly all hatched out, I swept the bees and a young queen they had managed to rear from the combs into an empty hive. Carrying off the combs to an empty room, I, after much labour with the spoon end of tweezers, cleaned out every foul cell. The next step was to wash all the combs with the disinfectant, special care being taken that every diseased cell should be filled with it.

The saturated combs having been replaced in the box, which was also washed with the solution, attention was directed to the bees. These I gave to a clean hive containing comb and eggs but no brood, and though not purified in any way, they have not given any evidence as yet of having carried disease along with them. Into the box which received the combs

washed with the disinfectant, a strong colony with a fertile queen at the head was introduced, but care was taken first to feed and roll these new tenants in the solution minus the essence of peppermint, which I fancied might well enough be dispensed with. My disinfected hive now became an object of interest, and I was very hopeful that the permanganate of potash, from its well known and powerful qualities, would effect what apiarians so much desire to find out.

In a few days the queen had deposited several eggs, and on the 23rd of September the two centre combs were well filled with sealed brood. To see whether they would all hatch out I took the queen away, but on making an examination on October 13th one-half still remained sealed, the covers of several being flattened and perforated. On probing them the treacherous contents showed their repulsive form, and proved that the complaint, instead of having abated, had been considerably aggravated. This was a disappointment. Like the author of the cure, I was sanguine of success before I had tried it, but failure only has followed, and I am sorry for it. No one, however, need be afraid of being mastered by foul brood so long as chloride of lime in conjunction with quarantine retains its undoubted and well-attested virtue.—R. S.

APIARIAN NOTES—CAUTION AS TO BUYING SECOND SWARMS OF LIGURIANS.

THE year 1869 was singularly unfortunate as regards the success of my apiary, so much so that, although I commenced the year with five stocks, at its close I had only two. The whole of my Ligurians perished; all my attempts to multiply them by artificial means proved futile; and I only saved one natural swarm in a Woodbury straw, and a driven swarm in a Woodbury cork hive. I bought another stock in a straw hive, and so commenced this year with three stocks. We had a very long, cold winter, no warm weather until April, and the first two weeks in May were very cold, with frosty nights, the temperature falling as low as 20°. Very few showers fell during April, and the bees in my two Woodbury hives seemed very weak; the natural swarm of 1869, owing, perhaps, to the age of the queen, was the weakest.

On the 20th of May, about 2.20 p.m., my first swarm went off from the straw stock. There was a strong wind blowing at the time, and I feared the bees would be lost, as they were driven about in all directions, but they fortunately settled upon a thorn bush over the hedge, where they were protected from the wind, and although it was in a very awkward position, and not a nice one for handling, owing to the thorns, I managed to hive them safely, and in a few minutes placed them in a Woodbury hive upon their old stand, removing the stock to a new position. The swarm worked away right merrily, and in about three weeks filled the hive; and as I did not wish for a virgin swarm, I placed a super upon it, but they never worked in it, although many of them were obliged from want of room in the hive to occupy it during the night. The stock in the cork hive soon recovered itself, and, as I did not wish it to swarm, I placed a super upon it also, but with exactly the same result; no honey was ever stored in it. The natural swarm never seemed to recover from the effects of the trying winter, and had enough to do to live.

Wishing to give the Ligurians another trial, I purchased a swarm in June, thinking I should manage better with it than with buying queens; but I found after I had agreed to take a swarm, that the party advertising them in your columns only sent out second swarms, keeping all the prime swarms himself. I thought this a very doubtful matter when I received such a message; thinking first that they would not be so strong, and secondly that it would be a doubtful case whether the queen would be properly impregnated, as she would have no opportunity except during the issue of the swarm, and the odds were at least ten to one that she would not be impregnated then. I wrote to the party, and he assured me that he had had seven swarms from one Ligurian stock in 1869, and they were all strong, so much so, that he expected the seventh would swarm the first this season. That seemed to settle the first difficulty; and as to the second, I thought I could at any rate try Mrs. Tupper's scheme for securing the impregnation of queens, and so decided to have them. They arrived all right, and were a very fair swarm, and had a fine queen; but I was doubtful she was not impregnated, and as I could not see any drones I concluded she could not be. However, after searching the combs over more narrowly, I managed to find about a dozen drones,

so made a large queen cage as directed, and placed them in it along with the queen, and then put them upon the bars of the hive, where they remained the allotted time, after which they were liberated.

A day or two afterwards I was unfortunately taken ill, and could not leave my room for some weeks, and no other eye but mine could detect anything that might be wrong. The first time I could get into the garden, of course I went to look at the Ligurians, and standing a minute before the hive remarked at once, "There's something wrong here." I was too weak to examine them that day, but a day or two afterwards I went, and taking off the crown board, saw at once that my fears were but too well founded; the swarm had evidently decreased, and I could only account for that on the assumption that the queen was lost. I carefully examined every comb, but could find no queen, nor a single egg or grub; so concluded she must have gone on her wedding flight, and either been lost or killed. I immediately placed a brood comb from a black stock in the hive, and they raised a fine queen, and she proved prolific enough, but the swarm never recovered itself sufficiently to stand the winter, and so has lately been united to the next. I think this should be a caution to others not to buy second swarms of Ligurians in the expectation of thereby securing a pure strain. Many—I may say all—who have not frame hives would be quite unable to manipulate the swarm in any way on its arrival; and as I feel sure that in nine cases out of ten (if I am wrong I hope Mr. Woodbury will correct me), the queen would not be impregnated before starting, and the buyer would at best only get a stock of hybrids, and the whole affair end in vexation and disappointment.

I have united the weak stock before mentioned to the swarm of this year, and so have made up two strong stocks in Woodbury hives; and as I never like to be beaten, I have two fine imported Ligurian queens, and placed them at their head, and so hope, if spared another season, to be successful yet in establishing Ligurians in my spary. I have also the black stock in the old straw hive, which I trust will prove useful in spring, as I intend to let the Ligurians swarm and then remove the stock to the stand of the black stock, removing it to a new one, and thus multiply the Italians while I try to keep down the black race. My honey harvest only consisted of four combs (the outside ones in the Woodbury hives), but they were moderately well filled, weighing nearly 14 lbs.—J. R. J.

* Presuming the swarm to be shut up on the evening of the day of issue and despatched to its place of destination, I should say you would be right in the tenth case also.—A DEVONSHIRE BEE-KEEPER.

OUR LETTER BOX.

GREAT HORTON SHOW.—The Secretary informs us that Messrs. W. and C. Burroston's prize was the only one overlooked, and has now been paid.

AWARDS—TRIMMING (Fair Play).—Your remarks are far too personal—both parties are writing to establish truth, not merely to have the last word. We are informed that Mr. Wright purposes a rejoinder.

TURKEYS' HEADS SWOLLEN (Constant Reader).—When the weather is fine, especially if it is sunny, let the Turkeys be out a longer time. If their run be one where they can get under ricks or into out-houses, let them be out all day. Grind some oats with the barley, mix green onion tops chopped fine with them, and if you can do it, mix with milk instead of water. Wash the swelled face with cold water and vinegar, and give to the affected birds two pills of camphor night and morning, each pill the size of a horse bean. If you can separate the sick from the healthy birds you will be wise to do so.

BANTAMS DYING (F. M.).—What sort of roosting house have your Bantams? What is the nature of the flooring? If it is brick, stone, wood, or asphaltum, it is probably the cause of your birds being out of condition. If not, then the birds are suffering from severe cold or roup. Wash their faces and nostrils with cold water and vinegar. Supply them scantily with water, give them lettuce and growing grass, with plenty of fresh mould, feed only on soft food, discontinue the meat and Indian corn. Give Baily's pills. If you have them not, or till you get them, give pills of camphor night and morning, two for a dose, each the size of a garden pea. If they seem sinking, give them some bread steeped in strong ale. The floors of poultry houses must be of earth.

BLACK RED AND GRAY DUCKWING GAME CROSSING (C. W.).—The cross you mention is often used, and serves to throw much brilliancy of colour into the progeny. In silver Duckwings it adds the copper saddle. The best way to breed either Black Reds or Duckwings pure, is to breed from pure parents on both sides. There is always more certainty in Black Reds than Duckwings, because experiments such as you speak of are often tried with the latter. You are quite right in setting eggs in February, and will have no trouble in rearing the chickens.

BRAHMA MOULTING (T. F. A.).—If it is only the buckle that is at fault, and all the rest of his plumage is perfect, you may safely shoo the cock. Give him a few peas, and every evening give him a little bread steeped in strong beer.

KILLING DUCKS ANNUALLY (A. D.).—We do not think it necessary to change the Ducks every year, but we are strong advocates for fresh blood every alternate year. Your question bears on age only. It is always well to put adults of one sex with juniors of the other. The advantage of breeding from young Ducks and an older drake is that they are earlier

layers than older birds; but the first eggs of any bird are not, as a rule, preferred. We believe you may safely breed from the same Ducks two, if not three years. Change the drake every alternate year; that is all the change you require.

POULTRY-HOUSE FLOOR—NUMBER OF STOCK (P. H. S.).—We do not think you gain anything by covering the floor of your poultry house with ashes; leave it as it is, as it is of earth. You may keep a cock and six or seven hens in such a place as you describe. You must, however, provide them on a small scale with that which they would meet with on a larger run. You must give them large sods of growing grass, cut with plenty of mould adhering. They must have some bricklayers' rubbish and some road grit. Both these should be put under the roofed part of the run. You may keep Brahmas, Crève-Coeurs, Houdans, or Cochins. The first and last are good sitters, the others are not. You cannot rear chickens without a run for them. As to feeding, why do you mix bran with barley-meal? It adds only to bulk, and is about as useful as the addition of sawdust to the quarter loaf. Fowls do not like buckwheat nor oats, nor are they good food for fowls. You will do well to confine your feeding in the morning to barley or oatmeal, mixed with milk or water; soaked bread and scraps of meat at mid-day, enough for a meal, and in the evening soft food as in the morning. You must recollect potatoes do not count for much in feeding poultry.

PIGEONS, RABBITS, &c. (Rustic).—Keep both very clean, and there will be no harm. We have seen both kept in a coach-house, the Pigeons breeding in boxes above, and the Rabbits in hutches on the floor. In the doors of the coach-house were large windows of wire netting. The owner told that both did well. In our number for October 27th we figured and described in full the Barb, to which we refer you. We never recommend dealers. Buy your birds of successful exhibitors who advertise their spare stock in our columns. Buy both your birds of the same person, or you may get one bad and one good, or one of an inferior strain.

DISEASED CARRIER (R. H. Keble).—It is difficult to judge of your bird by description only. If the lump is a hard corary wart, it might be cut out and the place dressed with caustic. If it be a hot and inflamed place, we should think soothing remedies would be best, such as bathing frequently with warm water.

METEOROLOGICAL OBSERVATIONS

In the Suburbs of London for the week ending November 22nd.

DATE.	BAROMETER.		THERMOMETER.				Wind.	Rain
	Max.	Min.	Air.		Earth.			
			Max.	Min.	1 ft.	2 ft.		
Wed... 16	29.826	29.286	48	20	41	41	S.W.	.00
Thurs... 17	29.597	29.415	47	18	41	41	W.	.00
Fri... 18	29.640	29.590	49	19	41	40	W.	.03
Sat... 19	29.334	29.212	49	24	49	40	S.	.10
Sun... 20	29.455	29.264	55	33	42	40	S.W.	.38
Mon... 21	29.308	29.265	51	34	45	42	S.	.12
Tues... 22	29.352	29.226	55	38	43	42	S.	.50
Mean..	29.415	29.265	50.29	26.57	41.85	40.85	..	0.90

- 16.—Fine; very fine; frosty fog at night.
- 17.—Frosty fog; very fine; frosty fog.
- 18.—Densely overcast; very fine; frosty fog.
- 19.—Sharp frost; cloudy but fine; rain at night.
- 20.—Clear and fine; very fine; heavy rain.
- 21.—Overcast; showery; heavy showers.
- 22.—Fine, very damp; showery; boisterous with thunder and lightning.

COVENT GARDEN MARKET.—NOVEMBER 23.

We have very little alteration to notice; there is still a large supply of inferior goods in the market, and prices are stationary. The importation of produce from the Channel Islands, however, has much fallen off, that of Pears particularly, and they are not of the usual good quality.

FRUIT.

	s.	d.	s.	d.		s.	d.	s.	d.
Apples.....	1	0	0	0	Mulberries.....	lb.	0	0	0
Apricots.....	doz.	0	0	0	Nectarines.....	doz.	0	0	0
Cherries.....	lb.	0	0	0	Oranges.....	per 100	6	0	10
Chestnuts.....	bushel	0	0	0	Peaches.....	doz.	0	0	0
Currants.....	doz.	0	0	0	Pears, kitchen.....	doz.	1	0	2
Black.....	do.	0	0	0	dessert.....	doz.	1	0	3
Figs.....	doz.	0	0	0	Pine Apples.....	lb.	3	0	6
Filberts.....	lb.	0	0	2	Plums.....	per 100	1	6	3
Cobs.....	lb.	1	6	2	Quinces.....	doz.	1	0	0
Gooseberries.....	quart	0	0	0	Raspberries.....	doz.	0	0	0
Grapes, Hothouse.....	lb.	2	0	6	Strawberries.....	lb.	0	0	0
Lemons.....	per 100	8	14	0	Walnuts.....	bushel	1	0	16
Melons.....	each	1	0	4	do.....	per 100	1	0	2

VEGETABLES.

	s.	d.	s.	d.		s.	d.	s.	d.
Artichokes.....	doz.	0	0	0	Leeks.....	bunch	0	4	0
Asparagus.....	per 100	0	0	0	Lettuce.....	doz.	0	9	1
Beans, Kidney.....	per sieve.	0	0	0	Mushrooms.....	per 100	1	0	2
Broad.....	bushel	0	0	0	Mustard & Cress, punnet	0	2	0	0
Beet, Red.....	doz.	2	0	0	Onions.....	bushel	4	0	0
Broccoli.....	bundle	0	9	1	pickling.....	quart	0	4	0
Brussels Sprouts.....	per sieve	3	0	4	Parsley.....	sieve	3	0	0
Cabbage.....	doz.	1	0	2	Parsnips.....	doz.	0	9	1
Capisiums.....	per 100	1	0	1	Peas.....	quart	0	0	0
Carrots.....	bunch	0	4	0	Potatoes.....	bushel	2	0	4
Cauliflower.....	doz.	2	0	0	Kidney.....	doz.	3	0	4
Celery.....	bundle	1	6	2	Ranishes.....	doz. bunches	0	0	0
Coleworts.....	doz. bunches	8	0	0	Rhubarb.....	bundle	0	0	0
Cucumbers.....	each	0	6	1	Savoys.....	doz.	0	0	0
pickling.....	doz.	0	0	0	Sea-kale.....	basket	3	0	5
Endive.....	doz.	2	0	0	Shallots.....	lb.	6	0	0
Fennel.....	bunch	0	3	0	Spinach.....	bushel	2	0	2
Garlic.....	lb.	0	8	0	Tomatoes.....	doz.	0	0	0
Herbs.....	bunch	0	3	0	Turnips.....	bunch	0	6	0
Horse-radish.....	bundle	3	0	0	Vegetable Marrows.....	doz.	2	0	3

WEEKLY CALENDAR.

Day of Month	Day of Week	DECEMBER 1-7, 1870.	Average Temperature near London.			Rain in last 43 years.	Sun Rises.		Sun Sets.		Moon Rises.		Moon Sets.		Moon's Age.	Clock after Sun.	Day of Year.
			Day.	Night.	Mean.		Days.	m.	h.	m.	h.	m.	h.	m.			
1	TH	PRINCESS OF WALES BORN, 1844. Linnæan	48.5	34.9	41.7	23	46	7	53	af 3	49	af 1	8	10	46	335	
2	F	[Society's Meeting.	47.4	33.7	40.5	19	47	7	52	3	7	2	20	af 1	9	10	23
3	S		47.0	35.8	41.4	24	48	7	52	3	23	2	28	2	10	10	0
4	SUN	2 SUNDAY IN ADVENT.	48.1	36.4	42.2	20	49	7	51	3	42	2	33	2	11	9	35
5	M		49.0	35.2	42.1	25	51	7	51	3	0	3	40	4	12	9	11
6	TU		48.2	35.7	42.4	23	52	7	51	3	22	3	46	5	13	8	45
7	W	Royal Horticultural Society, Fruit, Floral, and General Meeting.	48.4	38.5	43.5	21	53	7	50	3	49	3	52	6	14	8	20

From observations taken near London during the last forty-three years, the average day temperature of the week is 48.1°, and its night temperature 35.9°. The greatest heat was 62°, on the 1st, 1857; and the lowest cold 14°, on the 5th and 6th, 1844. The greatest fall of rain was 1.02 inch.

THE NEW PELARGONIUMS OF 1869.



HOWEVER much we may deplore the fact that the Pelargonium does not occupy the position in public estimation that it once did, it is, nevertheless, true that for some time the magnificent collections with which Turner, Bailey, Fraser, and others used to astonish the horticultural world have disappeared from our exhibitions. Mr. Hoyle, one of our most successful raisers, has given them up *in toto*; and the vendors of Pelar-

goniums tell us that they are not sought after as they used to be. I, whose earliest floral associations are connected with this lovely flower, cannot but deplore this, and must only hope that better times may come, and the Zonal tribe be obliged to give place to its more aristocratic relative; at present democracy carries the day. It is something, however, to be able to see that improvements are still being made in the flower, and although the usual complaint of sameness will doubtless be made concerning them as concerning others of our favourites, yet the improvement is gradual. Having had the opportunity of again growing the new varieties under my own eye, I subjoin the following notes made concerning them as they have flowered, taking first the LARGE-FLOWERING or Show section:—

Attraction.—A very pretty rosy lilac flower, quite a new colour; small maroon spot, and a clear white throat.

Bonnie Charlie.—Rosy crimson, the upper petals intense black or with a narrow edge of bright crimson; clear white throat.

Claribel.—Very pure white, with a small spot of very bright crimson. Most chaste flower, and quite distinct from other varieties in the same class.

Corsair.—Bright purple, pure white centre; top petals black, shaded. Good habit. This is also novel, and a very attractive flower.

Cycle.—Rosy purple, maroon top petals. Smooth.

Gratulation.—Rose petals, top dark crimson, with black spot, shaded; a pale rose edge.

Harold.—Crimson, pencilled lower petals; top petals black, with crimson edge. Free flowering.

Her Majesty.—A very bright pale pink flower, small black spot on the top petals, clear white eye.

Heroine.—A very beautiful flower, in the style of Mary Hoyle, small maroon spot on the top petals, orange rose edge, white centre. Good, dwarf habit.

Jerome.—Dark flower, in the style of John Hoyle; thin wiry foliage.

Llewellyn.—Rich deep crimson. Splendid colour, and a very striking flower.

Marion Wilkie.—Pale rosy pink, the same style as Her Majesty, but not so good a flower.

Maid of Honour.—Light rosy pink, small dark maroon blotch on top petals. A very fine flower, and by far the best of the pink varieties that we have.

Plantagenet.—Light rosy pink. A good flower, in the same style as the preceding, but not so fine.

Regent.—Crimson, with dark maroon top petals. A wiry habit of growth.

Velutina.—Purple, small spot on the lower petals, top black, shading to a purple edge. Bad habit.

Of these, then, I consider *Attraction*, *Bonnie Charlie*, *Claribel*, *Corsair*, *Her Majesty*, *Heroine*, *Maid of Honour*, and *Llewellyn* as the best.

The FANCIES sent out at the same time were very superior, and especially remarkable for the greater vigour of habit and the freedom of their blooming; in fact, the Fancies may now be considered almost as robust as the Show varieties.

Agrippa.—White, large pale lilac spot. A distinct and good show flower.

East Lynn.—White ground, crimson top petals, lower petals heavily marked with crimson purple, shaded; white eye.

Excelsior.—A very bright flower. Deep rose; white eye and centre. A beautifully-shaped flower.

Lady Carrington.—Soft pale peach, top petals shaded with pink; white centre.

Leopard.—A very strong grower, similar in colour to Lord of the Isles. Very good.

Marmion.—Rich crimson top petals, shaded with purple. Large and good.

Of these I should prefer *Excelsior*, *Leopard*, and *Marmion*, particularly on the point of habit.—D., Deal.

NOTES ON OUR NATIVE TREES.

WHATEVER merit the fashionable plantsman of the present day may take to himself or be accorded, there can be but one opinion, that Nature presents us with much grander objects in the magnificent trees of various kinds occasionally to be met with—trees which strike the beholder with admiration either at their size or antiquity, or perhaps both combined. It is mostly in the parks of our great landed nobility and gentry that such are to be found, with now and then a tree on some piece of common land which owed its preservation to the fact of no one having had authority to cut it.

In some of our natural forests, which, however, are now few, large trees are to be met with, and I believe the large trees in Welbeck Park are to be traced as originally forming a part of Sherwood Forest; whether those now remaining were coeval with the celebrated outlaw Robin Hood it would be difficult to say, but I believe there are authentic records of other Oaks having lived a period nearly as long. The Oak trees in Cadzow Park, adjoining Hamilton Palace, in Scotland, were, I believe, planted by royal charter some four hundred years ago, and certainly had not a more ancient look in 1865, when I saw them, than many others to be met with; neither were they such noble-looking trees as those which many parks in England contain. Some years ago a fine healthy Oak tree of large size was pointed out to me in the grounds of Earl Cowper, in Hertfordshire; it promised to be a noble specimen for centuries—it was so healthy, and it covered an immense space of ground. A still larger tree was cut down in the

park of the Marquis of Anglesey, at Beaudesert, in Staffordshire, in 1869. It contained upwards of 900 cubic feet of timber, mostly, if not all, sound. This tree was growing in the open park on ground far from what the farmer would call good, yet it had attained the size above-stated. Very fine Oak trees were also in great numbers a few years ago, and I believe are still, in the park of the Earl of Stamford and Warrington in North Cheshire. These, though not perhaps so old as some of the others I have mentioned, were excellent specimens of timber trees, and instead of being sparingly scattered about were almost too thick, portions of the park having the character of a forest. Knole Park, in Kent, is more remarkable for its Beeches than its Oaks, although both are well represented, and most other parks contain fine specimens of this noble tree. I remember some years ago measuring one in a hedge-row in Buckinghamshire upwards of 25 feet in girth, and having a fine, healthy, spreading top.

One of the most remarkable Oak trees in England, if it be still alive, and it was so twenty years ago, is the Glendale Oak in Welbeck Park, Notts. This noble tree was described by Evelyn in 1662 and measured by him, and its circumference at that time was as under:—

At 1 foot from the ground	33 feet 1 inch in diameter.
At 2 feet from the ground	28 " 5 "
At 5 feet from the ground	25 " 7 "

In 1724 this tree was hollowed out into an arch to allow a carriage to pass through it, and it became the common object of a drive for tourists and others to go through it. I expect, however, if it be still alive, that it will be taken proper care of. An engraving of it made some twenty-five years ago represented its top as very small compared with its trunk, and in all probability it may have ceased to put forth leaves, but I have not heard of its death. Other large trees are also said to adorn this park. The Great Porter is said to contain about 1300 feet of solid timber in its trunk and branches, the trunk alone containing 1100 feet. The girth of this tree at 4 feet from the ground is 27 feet 8 inches. The Little Porter, I apprehend, is smaller than its neighbour; but we are told there are other remarkably large trees in that noble park.

Beech trees of similar age to the Oaks are not uncommon, but seldom so large. I am told the Burnham Beeches, in Buckinghamshire, present a venerable appearance, but I have never had the opportunity of seeing them. Fine old trees are to be seen in the park of Sir Percival Dyke, Bart., of Lullingstone, in Kent, trees considerably more than 20 feet in circumference, I believe one as much as 25 feet. Large old trees are also met with in several parks in Hertfordshire, where Oaks are not so plentiful, the Beech being better adapted for the dry chalky soils common in those parts. Knole and Eastwell Parks, in Kent, are also remarkable for their Beeches, some avenues in the first-named park being very fine, but they have not yet assumed that antiquated appearance which the artist delights in, yet their large size promises that when that day shall arrive, there will be something magnificent to look upon.

Elms seem less enduring trees, arriving at quite as large a size as either of the others above named, but decay seems to set in at the root as soon as in the stem, and they blow down. Elms seem to take possession of the best of soil, and drive other trees from it, usurping, or nearly so, the whole to themselves, as shrubs or undergrowth seem to have a greater difficulty to maintain an existence under an Elm tree than anywhere else. Their roots also extend a long distance, and send suckers up every season in great numbers, to be cut down with the scythe if the field is a meadow, but the tree attains a great size. A timber dealer in this county once told me he cut down in East Malling Park, Kent, a tree that measured upwards of 1000 cubic feet, and was tolerably sound. It was, I believe, applied to some purpose in the Royal Navy. There are also some very large Elms in the park at Barham Court, not far distant from the park just alluded to, that are said to contain several hundred cubic feet of timber; and one in the grounds here, Linton Park, must contain upwards of 400 cubic feet, and many others are nearly as large. Nevertheless, the Elm is not a long-lived tree; rapid in its growth, and handsome in outline, especially in autumn, when its bright yellow foliage contrasts so well with the dark-coloured bark of its rugged limbs and branches, it is, however, a treacherous tree, large limbs dropping off on calm fine days without any warning. Still it must be regarded as one of the most important of our native trees.

Ash trees are, in general, more disposed to run upwards than spread, and trees with very stout trunks are not numerous; but we find now and then one of the latter class. In the

fine park of Sir Edmund Filmer, Bart., East Sutton, Kent, are several fine broad-topped trees, the circumference of the bole of one that I measured being upwards of 22 feet, but it speedily broke into branches, and the number of cubic feet it contained would not equal that of some Elms. Ash trees are prone to decay, but as an ornamental object the merits of the Ash have been unjustly decried, for when allowed fair play the outline of old specimens is very graceful, while the compound foliage and singular but handsome fruit would have more admirers, could the fact of its extreme commonness be forgotten.

Thorns, although not competing with the trees above named for size, nor utility as timber, are invariably favourites, and impart a feature of no mean importance to many parks containing good examples of other trees. A large broad-headed White Thorn in full bloom is not easily matched by anything we have, and I could point to several places where such trees form a most important item in the landscape. They are usually met with in the greatest luxuriance in dry stony places, where the subsoil is accessible to their roots for a considerable depth.—J. ROSSON.

(To be continued.)

IS ARALIA SIEBOLDI HARDY

WHEN this plant was first introduced into the country it was said to be quite hardy, but I am doubtful if it is so, for I have seen it injured by frost after having been grown for a few weeks as a cool greenhouse plant. This I know is not a fair way of proving its hardiness, but since I have been in the country I have heard more than one gardener say that it is not safe to trust it out of doors all winter without ample protection. I, and many others no doubt, would be glad to have more definite information upon this point, and if from correspondents living northwards so much the better. It will not only make a material difference in the value of the plant, but it would considerably increase its sphere of usefulness, should it prove hardy, for who would then be without the plant for the winter decoration of their gardens? Already its noble appearance, arising principally from its luxuriant growth and its large shining dark green foliage, which clothes the plant to the ground, have rendered it popular with most of those who have grown it for out-door summer decoration. It is a noble and most suitable object for planting in large vases, and possesses an advantage over many plants used for that purpose, as it stands the wind remarkably well. For sub-tropical gardens it is a very effective plant, and only requires to be more known to be appreciated.

So far I have only spoken of this beautiful plant when grown for its foliage alone, but its bloom is worth consideration. I do not think it is the least attraction the plant possesses, for even a plant from 2 to 3 feet high will throw up a pyramidal spike of flowers from 1 to 2 feet long, and as much in diameter at its base. The whole of the stem and bloom is almost a pure white, forming a very effective contrast to the dark green foliage. The plant produces fruit very freely, but I do not know what their colour is when they are ripe, nor how long they remain on the plant, as I am describing a couple of plants that are in flower at this place, and which are only now setting their fruit. These plants are planted out in the conservatory, so it is evident that my predecessor did not think them hardy enough to grow and flower out-doors as permanent specimens. I should not advise such a course to be taken unless the plant should flower early enough to get clear of winter weather, for assuredly the bloom would be destroyed, and the grower would lose a treat well worth the trouble of taking extra pains to secure. When I came here, three months ago, the plants were forming their flower buds; they soon afterwards threw up a spike and opened flowers, and have now been in bloom for some weeks. I have before this grown the plant in pots, and have found them do well in a rich loam, rather heavy but turfy, and with sand added. At this place the plants are growing in a mixture of light gitty loam, leaf mould, and rotten manure, and I think the foliage is darker in consequence.—THOS. RECORD, Hatfield Park.

GROUND LEVELLING AND PRACTICAL GARDEN PLOTTING.—No. 7.

DRAWING PLANS.

Fig. 29 is formed in a different manner from any of the former illustrations, so far as it is not based on any geometrical figure, such as a square, triangle, &c. It is the first in-

roduction to the way of transferring a plan from paper to the ground. Here it is transferred from one side of line *A B*, to the other side. With radius 1 *a*, draw arc *a a*; with radius 2 *b*, draw arc *b*; with radius 3 *c*, draw arc *c*; with radius 4 *d*, draw arc *d*, meeting arc *c* where the line is cut; with radius 5 *e*, draw arc *e*; and with radius 6 *f*, draw arc *f*, and *fig. A B C* is complete.

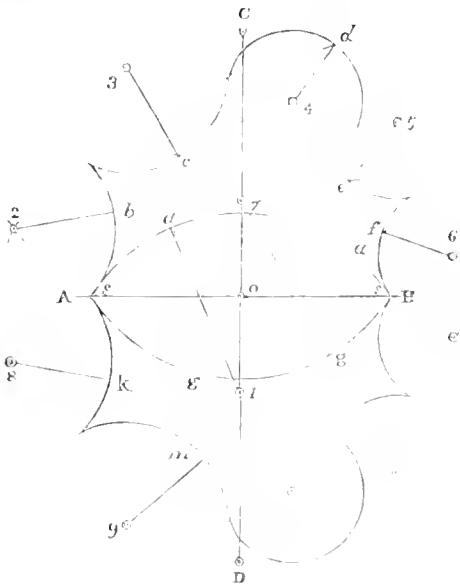

Fig. 29.

To draw a corresponding figure, it will be necessary to have recourse to other means than those employed in the formation of the foregoing examples. From the points of the bed *A B C*, as shown in *s s*, draw line *A B*, bisect line *A B*, and draw line *c D*, passing through point 1. Centre *o* is the principal point. With the dividers find the distance from centre *o* to point 1 on line *c D*, turn the dividers round and find the same distance on the other side, as point 7; from point 7, with the same radius as 1 *a*, draw *g g*, which is equal to arc *a a*. Here a pair of compasses with a pencil-leg will be necessary. Place the steel point of the compasses on centre *o*; extend the pencil-leg to point 2; place the pencil on the exact point, then turn the compasses round, and draw an arc as in point 8. Next shift the steel end of the compasses to point *c*; extend the pencil to point 2 as before, placing the pencil exactly on

end of the compasses to point *c*, and place the pencil on point 3. Remove the compasses to point *n*; with the same radius as *c 3*, draw an arc in point 9, cutting the former arc drawn from centre *o*. *D 9* is equal to *c 3*. From point 9, with radius 9 *m*, draw arc *m*. Arc *m* and *c* are equal. Find the corresponding centres to 4, 5, 6 in the same manner, and draw the corresponding arcs. When finished, *A B D* will be equal to *A B C*.

Fig. 30 is another exercise in the application of the above method of forming a complicated figure. The left-hand side of the figure, as *A C D*, is drawn without any reference to points *c* and *D*. But to draw the corresponding part, *B C D*, it is necessary to draw line *A B*, and erect the perpendicular line *n c*. Points *D* and *c* are the principal points from which the centres are taken from the left and transferred to the right-hand side, *B D C*. Put the steel end of the compasses down on point *D*; open the compasses and place the pencil on centre *I*, from which arc *c* is drawn, turn the compasses towards *a*, and draw an arc as in point *a*. Shift the steel end of the compasses to point *c*, open the compasses, and put the pencil down on centre *I* as before; turn the compasses towards *a*, and draw an arc, cutting the former one drawn from point *n*, as shown in *a*. Centre *a* is equal to centre *I*. From centre *a*, draw arc *b*, which corresponds with arc *c*. Find centres 2, 3, 4, 5, 6, 7, and 8 in the same manner, and transfer them to the right-hand side. Draw the corresponding arcs *d, e, f, g, h, k, and n*. From point *c*, draw arc *s*, uniting arcs *e c*, where the lines are cut, as in *t t*.—*M. O'DONNELL, Gardener to E. Leeming, Esq., Spring Grove, Richmond.*

THE POTATO AND ITS CULTURE.—No. 2.
PLANTING THE GENERAL CROP.

THE time for planting cannot be exactly predetermined, and I leave it as a period to be influenced by locality, position, and season. There are great diversities of opinion as to different methods of planting, and I will briefly state two of them, and then detail the way which I consider and have proved to be the best.

Some dig the ground and plant it as they go on; when a space about a foot wide has been dug, a line is cut across, and a small trench is cast out, manure is put into the trench, and the set is placed on the manure (in some instances the manure is placed on the sets); enough ground is then dug for another row, and so on.

The second mode is to manure and dig the ground required for Potatoes, and insert the set by means of an iron-shod dibber; the holes are then covered in with a rake.

I will now narrate my own plan. In the first place, the plot of ground which is selected for the crop, if very light, will need nothing except some well-decayed manure to make it more retentive of moisture; but should the ground be stiff, mix well-chopped meadow turf, not riddled or sifted, with a little lime and leaf mould, and dig it in a full spade's depth. The sets should be whole Potatoes, about the size of a small hen's egg; the end having a cluster of small eyes should then be cut off each Potato, and those which are larger may be cut into pieces, leaving on every set not less than two eyes. In planting cast a line from one end of the ground to the other. A man should then open a hole with a small spade, or, which is better, a grafting tool, such as drainers use; a lad should then be placed in front of the man, and drop the sets into the holes as they are made, and before the spade is withdrawn, so that the withdrawal of the tool may cover the set.

When the young shoots make their appearance above ground care must be taken to keep it hoed, to subdue the weeds, and to keep the surface from caking. If the weather be very cold and wet, finely-sifted ashes may be put over the rows (just as the young shoots make their appearance above ground) in the shape of a ridge, this will facilitate the growth and protect the young plants.

All early kinds of Potatoes may be earthed-up, but late varieties do best not earthed-up, but observe they must be planted more deeply than the earlier. This is not applicable to the Potato in the field, for in many cases the soil does not run deep enough.

TAKING UP AND STORING THE PRODUCE.

The keeping of the Potato greatly depends upon the condition

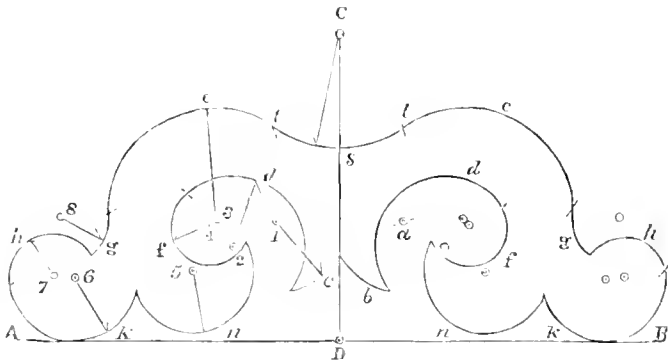

Fig. 33.

the point. Shift the steel end of the compasses to point *n*. Seeing that points *D* and *c* are exactly the same distance from centre *o*, draw an arc in point 8, cutting the former arc drawn from centre *o*. Points *D* and 8, are equal to points *c* and 2. From point 8, with the same radius as 2 *b*, draw arc *k*. Arcs *k* and *b* are equal. Again place the steel end of the compasses on the centre *o*, and place the pencil in point 3; turn the compasses round, and draw an arc as in point 9. Shift the steel

of the crop when it is dug up. The tubers for keeping must be ripe. If ripe their skin will not rub off if exposed to friction, but ripeness is first shown by the haulm turning yellow, with an inclination to dry up.

The Potatoes which are intended for culinary purposes should not, after being forked up, remain on the ground any longer than to dry thoroughly, which, if the weather be fine, would not take any longer than one day. On the other hand, the Potatoes for planting should remain on the ground, placed on boards, or something of the kind, to become green and hardened—the boards prevent the tubers getting damp, which they would do if laid on the bare ground. It is indispensable to let the Potatoes be well greened, for they are then far less likely to produce a crop liable to disease.

A dry warm day should be chosen for the operation of forking up the produce. There are several ways of storing Potatoes; some have houses, others use cellars, and others pit or clamp them in the open ground; and this last is the most common mode, and not the worst—indeed, I like it the best, and I will endeavour to substantiate my preference. The Potato requires to be kept moist and cool—moist, because if allowed to get very dry it loses its flavour and firmness; cool, because if heated by fermenting in a heap it will usually become soft, and eventually decay, or will sprout unseasonably. Care must be taken, by covering the pit or clamp at least with a foot's depth of earth, to exclude cold and rain.

To secure good sound Potatoes, if the crop is large the pit should be made long, but if limited a round pit is best. Let the soil be dug out a good spit deep, lying the earth and the crumbs around the hole. Place at the bottom some dry straw, fern, or leaves, but fern is the best, and on this litter place the Potatoes in a pyramidal heap. When a sufficient quantity has been put in cover them thickly with dry litter, and on this place a coating of soil fully a foot in thickness, and well beat it with the spade, to keep it in its place and to shoot off the rain. If the pit is long and large, wisps of straw tightly bound round should be built in as the pit advances, at about 10 or 12 feet apart, and project through the earth covering—this prevents heating; if the pit is round one wisp will be sufficient.

In storing Potatoes for seed, I have always found it best to pack the Potatoes in straw, both at the bottom and on the top, placing them on a stone or plaster floor, in any position where there is a current of air passing underneath. The Potatoes must be watched, and if inclined to shoot or sprout they must be laid out thinner, and in no case should the sproutings be rubbed off, for if they are watched, and the tubers laid thinly, they will not advance sufficiently to require removing, and instead of throwing out long, weak shoots, stiff, healthy, shoots will be produced.—J. C. LEWIS, *Gardener and Bailiff, Sudbury Rectory, Derby.*

FRUIT TREES FOR SMALL GARDENS.—No. 3.

After planting, bush and pyramidal fruit trees certainly require more attention than standards, for they will need summer pruning, and top-dressings of manure; but whilst the annual attention and labour will be greater, there is an ample compensation in the greater and earlier produce of bush and pyramid, as compared with standard trees. I need not further dilate on the advantages of growing fruit on pyramids and bushes, but will close these papers with a few hints on the varieties to cultivate.

I must thank Mr. Rivers for his short article in reply to my request for a list of fruit trees suitable by their productiveness and good quality for small gardens. The selection given at page 322, by Mr. Rivers, I consider excellent in every respect, good bearers, and good in quality. I have grown in the west most of the kinds named by Mr. Rivers, and many of them have I seen doing well at a considerable elevation in Wales on the hillsides o'er which Yvel Yamma flows. I was particularly anxious to have his advice on this subject, because he could bring to bear an amount of experience which few or none of the fruit growers of this or any country possess; and secondly, he, as a nurseryman, has opportunities of testing a far greater number of varieties than most fruit cultivators in private establishments; also he has experience in a more southerly situation than I have been. My experience has been north of the Humber and a line drawn straight across to the Irish Sea. Now, I am in the north-east corner of North Yorkshire, about 300 feet above the sea, and perhaps three miles from it as the crow flies, exposed to its full effects when the wind blows from the east. South, and to a great extent west-

ward, there are miles of moor. What succeeds here will do so almost anywhere. I must, however, state, we are well sheltered to the north by plantations.

PEARS.—1, Williams's Bon Chrétien does well, being very prolific, large, and good; end of September. 2, Beurré Giffard, forms a tree-growing pyramid, fruit medium size; beginning of September. 3, Bergamotte Esperen, extraordinarily prolific, medium size; February onwards. 4, Beurré Hardy, vigorous pyramid, fruit large; beginning of November. 5, Alexandre Lumière, good bearer, medium size; November this year, but generally December and later. 6, Fondante d'Automne, medium size; October. 7, Beurré d'Areberg, prolific, medium sized; beginning of November this year, generally December. 8, Seckle, small, great bearer; October. 9, Beurré Diel, large, prolific; November. 10, Marie Louise, large; October and November. 11, Zéphirin Grégoire, medium size, great bearer; December and January. 12, Comte de Lamy, medium size, good bearer; October.

These are all very hardy, fine, and healthy both in tree and fruit. Passe Colmer bears abundantly, but the fruit is small; November. But for (than any for growth and fruiting is Beurré de Capiaumont, yet it is not of first-rate quality; October. Louise Bonne of Jersey is very prolific, but the fruit is small and much pitted. Against a wooden fence (open trellis), it was excellent; October. Etienne de Mello, good bearer, fruit small; November. Beurré d'Anjou, Winter Nolis, and Beurré Superfin generally bear well, and are pitted. Beurré Bachelier, large, good bearer; December. Beurré d'Amanlis, large; September. Joséphine de Malines is a great bearer and good; February. The last three I would add to the first twelve, but I have no pyramid trees of them. I have found they generally succeed in the north. I might extend the list by noting some that occasionally do well, but from the uncertainty I think it well to leave them unnoticed.

APPLES.—*Kitchen*—1, Lord Safford, very large; October and November. 2, Cox's Pomona, large; December. 3, Dumelow's Seedling, large; December to March. 4, Northern Greening, large; December to April; 5, Gooseberry Apple, large; December to beyond May. 6, Rymer, large; December to April. Those six I can confidently recommend as the best for a cold or, indeed, any climate, as kitchen Apples, either for private use or growing for sale. 7, Norfolk Bearer, large; December to February. 8, New Hartborden, large; December and January. 9, Keswick Codlin, good for jelly, and the best early kitchen Apple. 10, Tower of Glamis, large; November to February; 11, Blenheim Pippin, or Orange, large; November to February. 12, Winter M-jeting, large; November to March. The above are all good kitchen Apples, great and certain bearers. Apples, in my opinion, are best as bushes, especially those with large fruits, as all the kitchen Apples should be, and as the preceding are.

Dessert.—1, Cox's Orange Pippin, medium-sized, very handsome; November to January. 2, Early Harvest, medium-sized; August. 3, Kerry Pippin, medium-sized; October. 4, Kedleston Pippin, small; December to March. 5, Red Astrachan, medium-sized; September. 6, Scarlet Nonpareil, medium-sized; January to April. 7, Sturmer Pippin, medium-sized; January to May. 8, Melon Apple, medium-sized; December to February. 9, Mannington's Pearmain, medium-sized; November to March. 10, Reinette du Canada, large; March to May. 11, Nonpareil, Old, medium; April. 12, Pitmaston Nonpareil, medium-sized; December to February.

Desert Apples having, as a rule, smaller fruit than kitchen Apples, are better adapted for pyramids. I ought to name Margil, medium-size, as a good bearer; November. It has a smack of the Ribston flavour. Court-Pendü-Plat, medium-sized, January to April, is excellent.

PLUMS—*Kitchen*—1, Early Orleans, red; end of August. 2, Oullin's Golden, yellow; early in September; very vigorous, a marvel of productiveness. 3, Prince Eaglebert, purple, large; September. 4, Early Prolific (Rivers's), purple; beginning of August. 5, Autumn Comète, red, large; not unlike Victoria, but later. 6, Yellow Magnum Bonum, large; end of September. 7, Damsou, Cluster or Prolific, bears profusely as a pyramid. 8, Victoria, red, large; end of September.

All the preceding are good kitchen Plums.

Dessert—1, July Green Gage, medium-sized, greenish yellow; August. 2, Belgian Purple, rather large, purple; end of August and beginning of September. 3, Jefferson, large, yellow; September. 4, Green Gage; September. 5, Kirke's, large, purple; end of September. 6, Angelina Burdett, medium-sized, purple; September.

These are all good bearers, but the fruit does not attain a high degree of excellence, yet is good. Transparent Gage does not ripen, nor does Coe's Golden Drop; and Reine Claude de Bayar cracks and splits up into all kinds of forms, besides not ripening. In some sheltered situations in the north they may do. Where they will, they should have a place, for they are most excellent.

CHERRIES.—Kentish, medium-sized; Morello, large. These two are for kitchen purposes. The trees are very prolific as pyramids. Archduke, later by ten days than May Duke, bush; Empress Eugénie, large, ten days earlier than May Duke; May Duke; Transparent. These are all of the Duke race. Bigarreau, and Bigarreau Napoleon, of the Bigarreau race; Werder's Early Black, and Governor Wood, one of the Hearts. The last eight are good bearers, and dessert fruit.

For those that have only room for a very few trees, I give a selection of three of each—viz., *Pears*: Williams's Bon Chrétien, Beurri Hardy, and Zébulin G'égoire, or if a late one, Bergamotte Esperen. *Kitchen Apples*: Lord Suffield, Cox's Pomona, Damelow's Seedling. *Dessert Apples*: Early Harvest, Cox's Orange Pippin, Pitmaston Nonpareil. *Kitchen Plums*: Early Prohibe (Rivers's), Prince Englebert, Oalhn's Golden. *Dessert Plums*: July Green Gage, Belgian Purple, Jefferson. *Cherries*: Empress Eugénie, May Duke, Archduke; and Kentish for tarts.

The Pears should be on the Quince stock, the Apples on the English Paradise stock, and the Cherries on the Mahaleb or Cerasus Mahaleb.—G. ARREY.

A HORTICULTURAL SOCIETY FOR ULSTER.

It is in the great manufacturing centres of England and Scotland that horticultural exhibitions are most appreciated and successful, and horticultural science finds its most devoted and enthusiastic votaries. It was, therefore, anomalous and not at all flattering to such a city as Belfast to be without an established institution of that kind, and that its efforts hitherto in this direction should be merely spasmodic and intermittent. It is pleasant to record the fact of energetic measures being now taken to remove the reproach. During the present year a movement was instituted, and a two-days exhibition, on a large scale, held in the Belfast Botanic Garden, in the first week in September. Though on that occasion the second day was far from favourable, the affair was a success, and encouraged the promoters to go a step further, and establish a North of Ireland Horticultural Society, with the view—as the prospectus now before us states—of promoting “the pursuit of horticulture in all its branches, in every part of the province, and in some degree (since its exhibitions will be open to exhibitors from every quarter) in every part of the island, and even of the United Kingdom, and among every class of people.” With this object, it is proposed to hold exhibitions every year in Belfast, “not fewer than two, nor more than three,” at which prizes shall be given for every description of garden produce, and at each of which special prizes will be offered for specimens grown by cottagers and artisans.

This last is an important point as regards a town like Belfast, where, among its operative classes, one should look for the same horticultural enthusiasm as exists among the “stockingers” of Nottingham. We trust the new society will make its influence widely felt in this direction. It is evidently the intention of the Committee that this should be the case, for they tell us there is nothing which they “look upon as more desirable or more really beneficial to the community at large than to encourage a taste for gardening among the classes who depend on daily wages, and who in this way, it is hoped, may be led to find a healthy employment for their hours of recreation, and to take an honest pride in the embellishment and comfort of their homes.” The young Society hopes one day to be able to extend its operations beyond Belfast, and in course of time, if the funds permit, to be able either to hold exhibitions in other towns which may wish it to do so, or to aid those exhibitions which are already established, by subscribing to their funds or by giving additional prizes at them.

His Excellency the Lord Lieutenant has kindly consented to be the patron of the Society, and, with characteristic liberality, he further gives a cup, value ten guineas, which will be competed for at the first show, to be held in the Royal Botanic Gardens, Belfast, on Thursday, May 18th, 1871. It will be remembered that his Excellency also gave a cup of the same value to be competed for at the show held last September. The schedule of prizes for the first or May show, next year, is already issued; and from a copy now before us we are glad to perceive the prizes are

sufficiently liberal to tempt some of our metropolitan exhibitors to a trial of skill with our northern friends. Grapes, Peaches, and Pine Apples are, at all events, portable enough; and for two bunches of the first-named the first prize is £3, the second £1 10s.; for Peaches, £2 and £1; and the same for Pine Apples. Four new plants sent out since January 1st, 1870, are not likely to be over-large—nay, perhaps they would go in a very small space; and yet for such a class the spirited proprietor of the *Belfast News-Letter*, J. H. Henderson, Esq., J.P., offers a cup value five guineas, with a second prize of two sovereigns.

Copies of the schedule, as well as of the regulations for the exhibitions, may be had on application to Mr. J. F. Johnson, Botanic Gardens, Belfast; or C. D. Yonge, Esq., Honorary Secretary, Notting Hill, Belfast. It is, we believe, to the latter gentleman, who is no less enthusiastic a horticulturist than he is distinguished as a scholar, that horticulture in Belfast owes in a great measure the impetus and, thus far, the carrying to a successful issue of the movement for establishing on a firm basis the North of Ireland Horticultural Society, and thus wiping away what has been so long something very like a reproach to the good taste and spirit of the metropolis of Ulster.—(*Irish Farmer's Gazette*)

LABELS FOR FRUIT TREES.

A CORRESPONDENT, “C. C. E.” (page 350), takes exception to the method of labelling fruit trees advocated in page 329. He believes “chemical action takes place between the label and the wire, besides the harder edge of the zinc cutting the softer lead wire, so that in twelve months all his labels were on the ground.” Now, I believe, and I have studied chemistry a little, that all the chemical action incited between a zinc label and a lead wire never could have cut through the latter in the short space of a year, if at all, especially as the inciting fluid could seldom have been more potent than rain, and even that only occasionally. Had the chemical action been referred to the zinc label and the copper wire, I should more readily have trusted in his belief, as these are the very metals most generally used to induce chemical action, or, I may say more appropriately, galvanic action.

But gum and canker are referred to the use of these labels. Now, pomologists allege that the latter is caused by tap-roots striking deeply into cold crusty soil, and producing soft unripened wood, which has its tissue ruptured by intervening frosts, and consequently canker is the result. At the same time I will not deny that cutting the bark of stone fruit trees will produce gumming, if the labels be hung on loosely, but that branch only on which the label is hung will be so affected. But why allow the bark to be cut at all? A little attention acts as a preventive. Punch a sufficiently large hole in your label, and use thick lead wire for very obvious reasons. Pass the wire through the hole, give it a twist or two to make it tight, then encircle a branch near the stem, or a smaller one near a main branch, with the two ends, which twist round each other till they clasp the branch pretty firmly; then bend the label close to the stem or main branch, where the wire, soft and easily manipulated though it be, is yet quite strong enough to keep it, and prevent its being “a sport of winds and the ruin of the bark.” As the wood and bark are seen to swell slacken the wire a little, so as to prevent the bark from cutting, and the remedy for a time is complete.

The above method is not new. It has been recommended to me by an uncle, a gardener by profession, a most successful and intelligent pomologist as well as floriculturist, who applied it for years without evil results.

“C. C. E.” is now using a strip of lead stamped with the number which corresponds to the particular tree in his orchard book: allow me to suggest to him the stamping of the name instead of the number. A set of letters will, no doubt, cost more than a set of numbers, but consider the gain to pomological learning that may thus ensue. Who has not felt the disappointment of examining a tally to learn the name of a plant, and finding only a number? Let fruit-growers adopt any plan they please, but with all earnestness let me say to them, Attach names to your fruit trees.—A. R.

NAPOLEON'S FLOWER.—The Violet is the emblematic flower of the Buonapartes, as the Lily is of the Bourbons. When Eugénie agreed to accept Napoleon's offer of marriage, she expressed it only by appearing one evening dressed in an exquisite Violet toilet—Violet in her hair, in her dress, even to a branch

in her hand. Louis Napoleon understood, and it was his only answer. Napoleon while consul selected this as his flower. It was through Josephine asking him to bring her a bouquet of them on her birthday—a desire he was only able to serve after very great difficulty. He cultivated them assiduously while a prisoner at St. Helena; and they were profusely planted over the grave of Josephine. After his death his coffin was covered with the humble flowers he loved. It is even said that in the earlier days of Louis Napoleon, he was silently made acquainted with who his secret friends were, by a cautious display of Violets.

THE ROYAL BERKSHIRE ROOT SHOW.

The twenty-first Exhibition of roots, annually held in Reading, and which is now generally known as the Royal Berkshire Root Show, took place on the 26th ult. in Messrs. Sutton's large stores in the Market-place. This Exhibition is conducted at the expense, and under the management of Messrs. Sutton & Sons. The competition is not confined to the immediate district of Reading, but is open to all comers; and from England, Scotland, Wales, and Ireland, we here find brought together such a collection of roots, that the Show may fairly be termed extraordinary when the unusually dry summer is taken into consideration. The number of entries this year exceed those of any other, being nearly 400 against 270 in 1869, and 250 in 1868. There are also very fine collections of Turnips, Kohl Rabi, Carrots, Cabbage, and Potatoes; among the latter we noticed the Bovinia or Cattle-Feeder, and Suttons' Red-skin Flour Ball, of extraordinary size and fine quality. The following is a list of awards for roots cultivated in gardens:—

12 Parsnips, R. W. Hall Dare, Esq., Newtownbarry, Ireland; 2nd, Mr. B. Lane.

12 Red Carrots, Messrs. Virgo & Son; 2nd, J. Bates, Esq.

12 Reading Onions, Mr. Thomas Naschy, Banbury; 2nd, Mr. J. Cave, Rickmanworth.

24 Kidney Potatoes, P. McKinlay, Esq. (Early Rose); 2nd, John Bates, Esq. (King's).

24 Round Potatoes, F. G. Jones, Esq., Bala (Suttons' Red-skinned Flour Ball); 2nd, the Reading Union.

Extra Prize, for collection of seedling Potatoes, Mrs. Betsy M. Paterson, Dundee.

The Judges were Messrs. Wilkins (Mortimer), J. B. Spearing, and Jenkin Davies, whose decisions appeared to give general satisfaction.

We understand that some of the finest specimens will be exhibited on Messrs. Sutton's stand at the Smithfield Club Cattle Show.

THE LAW OF FASCIATION AND ITS RELATION TO SEX IN PLANTS.

[Read before the American Association for the Advancement of Science.]

At the last meeting of the Association Dr. Sterry Hunt handed me a fasciated branch of *Picea balsamea*, in which the branchlets of the fascicle presented a very distinct appearance from the normal form. In the language of the person who directed Dr. Hunt's attention to it, it seemed as if a Norway Spruce was being developed from the Balsam Fir. From facts I had previously observed, and embodied in my paper on Adnation in Coniferae, read at Chicago, it was clear that these branchlets did not possess the adnating power which I showed in that paper to be characteristic of the highest vigour. The leaves were not distichous, but scattered around the weak stems, terete, and in every respect like those on plants in the young seedling state; and corresponding in this character with the free leaves in *Arbor Vita*, *Juniper*, and similar plants, when the branches are forced to grow in shady places, or under other conditions unfavourable to perfect nutrition. I was astonished at the suggestion that fasciation could possibly be a weakness of development; because, though very little has been written about this phenomenon, all that I have read refers to over-nutrition as the probable cause. I believe I can now offer some facts which will show that there may be two distinct causes of fasciation—one an abundant supply of nutrition, which consolidates together parts normally free, as we often see in *Asparagus*, *Plantains*, *Dandelions*, and other common things; the other a weakened flow of vitality, which is not able to combine parts together, which usually go to make up the integrate structure, and which then take the form known among the people generally as "Crow's-nest branches."

That the last cause was probable in the case before me, I saw, as I have already stated. I found several specimens on living trees of Balsam Firs near me similar to the one given to me by Dr. Hunt, and watched them frequently. That they were weak developments was clear from the fact that they made little more than an inch of growth every year—that the leaves, usually of a dark green, were of a paler hue—they were destroyed by the first frosts of autumn, becoming as deciduous

as the Larch, while the regular leaves continued evergreen—and many of the fasciated shoots died during the course of the winter. The pale tint was evidence of defective nutrition, as it is well known to every practical gardener that when, from any cause, the fibres of a plant become injured, and the free supply of sap is from any cause, as by ringing the bark, cut off from the leaves, they become of a pale sickly hue. It was also evident from the inability of the fascicle to keep its leaf green, and some of its branchlets alive during winter, that vitality was at a low stage.

I examined the fasciated branches on other kinds of trees, and found these general results in all; but in none so well illustrated as in a *Sassafras* tree, which had nearly all of its branches in this condition, one of which I exhibit. Another tree was alongside of it quite free from this character. The one with the fasciated branches was not nearly as large as the other, although there appeared no reason in soil or other circumstances why it should not be. A great number of the branchlets in the fascicles also died out every winter.

I was very anxious to find how these fasciated branches would behave in a state of inflorescence, but could not find any case of one bearing flowers. At length I discovered them in the common Blackberry, *Rubus villosus*, and was pleased to find that they not only confirmed the view I had taken of the cause of this kind of fasciation, but also furnished in the most unexpected manner new facts in favour of my theory of last year respecting sex—namely, that the male is the offspring of a declining vitality. These fasciated branches in *Rubus* I am inclined to think common, and it will be very easy to verify the following facts:—In these fasciated branches the number of branchlets varies from five to fifteen.

The pale tint characteristic of failing nutrition is particularly marked, while the lower leaves die away earlier than in those branches on the same cane produced in the regular way. That the whole of these leaves will fall first I anticipate, but cannot speak from actual knowledge. Here are perfect evidences of failure of nutrition, decreased vitality, and fasciation all going along together.

Now in its relation to sex. I pointed out in my paper on this subject last year, that the flower-bearing parts of plants were weak in proportion as they diverged from the feminine condition. In a polygamous plant the pistillate flower is on the stoutest axis—the hermaphrodite the next—the male the weakest. So also in the grades of masculine weakness. When the male flowers had their stamens reduced to petals, the plant or axis of the plant was weaker than before; and when the sepals took on the character of leaves, or the leaves lost their chlorophyllous character and simulated petals, vitality was well known to horticulturists to be in a weaker state than in other cases.

Here are the same illustrations. As you see in this specimen, the lower branches, pushing in the usual way, have the regular calyx segments; but in the upper set of fasciated ones the segments have taken on a leaf-like form, the stamens have increased in size, and the pistils, as shown by the great number in some flowers which have failed to swell out their ovaries, are proportionately defective. A tendency to masculinity is clearly in connection with defective nutrition, decreased vitality, and fasciation.

I saw this, however, still more clearly demonstrated in a field of a cultivated variety of Blackberry—the *Wilson's Early*, on the farm of Mr. W. Parry, of Cinnaminson, New Jersey. His son Levi, an intelligent and observing young man, called my attention to the fact that wherever these fascicles occurred the flowers were nearly double, and no fruit followed. I found this to be the case so far as the flowers were concerned. In some there were as many as twenty petals, and the calyx segments were largely foliaceous. There could not be clearer illustrations of masculinity and fasciation going along together.

Returning to fasciations of the "Crow's-nest" kind, we may then safely say that they are bundles of branches formed from germs, which, if nutrition had been sufficient to provide the required vitality, would have adnated together and formed one vigorous united axis, instead of as now, each struggling on in its own weak way. I am aware that this conclusion may conflict with received theories as to the formation of axis or stem. It would seem to imply that one perfect branch is but a collection of smaller homogenous ones. I sometimes see cases which indicate that this may be so. I have here a portion of a cane of *Rubus occidentalis*. At the base it is no thicker than the average of other canes; but near the middle of its length it has separated into four smaller canes. It has been usual to

regard these cases as the result of an easy and accidental union of several points; but in this case there is no increase in bulk—nothing but clear assumption to warrant any such a theory. On the contrary, every appearance suggests, not that the union of branches is the accident, but that that is the normal condition; and that it is the division into the fasciated branchlets which is the departure from the rule.

I do not, however, wish to ask for this suggestion anything more than it may be worth. Others more able than I can interpret the circumstances. The main object I have had in this paper, is to show that all the circumstances which accompany fasciation are those connected with a low stage of vitality. On this I think there can be no mistake.—THOMAS MEEHAN.

[At the conclusion of the reading, Mr. Meehan said that as he had already observed in the paper, he had not been able to find fasciated bunches with flowers, except in *Rubus*, so as to draw many facts from sex as to the causes of fasciation. But while with the excursion of the Society to Albany the day before, he had found a plant of *Atriplex rosea* with a fasciated branch. He exhibited this specimen, and showed that it had eight branchlets from the fasciae and all had male flowers only, while each of the other branches of the plant bore male and female flowers, separate, and according to the law he had already pointed out in his paper on sex—namely, with the male flowers on the weakest axes, and the female on the stronger ones.]—(*American Gardener's Monthly*.)

We lately were shown a very remarkable example of a fasciated stem of the *Tropæolum majus*. It was about a yard long, fasciated throughout, and sprinkled over with diminutive leaves. It grew in the garden of Capt. Hall, Notting Hill, Kensington Park.—EDS.]

KEEPING ICE.

I THINK there are many disappointed in the keeping of ice as well as "G. Y. M.," for I have the supplying of a large establishment through the summer, autumn, and winter. I think the way I manage my ice houses may be of interest to some of the readers of this Journal, for I met with many disappointments till I hit on the present way of managing it.

I have two houses in the shrubbery close to the lake, where the sunshine never intrudes. It is completely enclosed with large trees. My largest house is 20 feet deep by 15 wide at the top, gradually narrowing to the bottom. My other house is not quite so large; it is 15 feet by 9. This smaller house does not keep the ice nearly so long as the larger one—the larger the stack the longer it keeps. In filling the houses I make a large stack in the shade close by, which lasts till July. Generally when the ice is an inch thick I set to work, have it well broken on the bank, then put it in the houses, and have it very heavily malleted inside, using large mallets of about a stone weight each, thus forcing it very firmly together. Then I pour some boiling water on it, which makes it unite very well into a mass. I pour on the boiling water about ten times during the filling of one house. I find straw a very bad cover for ice. I have also tried sawdust, but I prefer clean dry leaves. Of course too much of leaves must not be put on, so as to cause heating. I put on about 3 inches thick all over the stack, then I add a little more in the summer to keep it cool. If it be freezing after filling the houses, I leave the doors open, and put nothing over the ice till the frost is gone.

By thus managing I have still plenty of ice in the larger house. I never cover up the doorway, but by shutting it closely there is just room left for the foul air to pass away. I need to have it latched, and then when I opened it there was a steam or vapour in the house, which caused the ice to melt very fast. By this management I am able to supply two barrows daily, and have enough to last till next February. The ice always melts from the sides a little, but it is in such a hard block that it requires a crowbar to loosen it. By making a large stack outside it prevents the need of opening the houses, except to see how they are going on, till July.—E. E.

[We consider these results of practice very reasonable, as frost and ice may be expected ere long. Beginners may compare them with the note at page 415. Too much strew cannot be laid on having ice houses and ice heaps of a good size. One thing we do not understand—using boiling water to consolidate the ice. When the ice is very hard and thick in severe frost, and therefore difficult to pound, watering with ordinary water would be an advantage. Lately our ice was too slushy to need watering. It may be the most scientific mode to use boiling

water, though we do not see why and how. We gave up using salt for consolidating ice, because we saw it proved of little or no benefit, though to this day the general reasons assigned are rather more puzzling to us than the use of boiling water.]

MUSHROOM-HOUSE MANAGEMENT.

We have had recently to depend on our open shed, and have gone on very fairly. We have thrown some stable dung into a heap, watering when necessary, and will turn it several times to have it rather sweet, to form the first piece of a bed in our Mushroom house. As the house is getting out of order, we are putting in fresh-sparred wooden platforms. Where platforms are used, brick, stone, and slate are better than board, but oak and even 1½-inch deal last a long time. With all the attendant steam we think our last beds lasted about fifteen years, and a good many of the uprights and bearers were sound even then. In a low house, wide enough to have a bed 4 or 5 feet in breadth on each side, it is the most economical mode to have no platforms. In the winter months, however, if anything, our platform-beds generally succeed best. Of course, if there is a bed coming on below, the bed above it has the benefit of the heat, and nothing suits the Mushroom better than the moist heat from decomposing rather sweet dung, and without the dung in some shape we can do little with the Mushroom.

There are two drawbacks to the free use of this moist heat in a Mushroom house. If the roof is not very smooth and airtight, the moisture will act upon it, and cause it to decay prematurely. Then, again, the moisture condensed on the roof—and that moisture, if from dung, not always clear and sweet—is apt to drip on the Mushrooms and rather injure their colour. This could to a great extent be remedied by having ventilators placed at the highest point in lantern fashion; but then whatever the Mushroom may delight-in in the open pasture, it does not like keen draughts under cultivation. The chief antidote for both these evils is to have a smooth-plastered ceiling, and then to paint that ceiling when dry with boiled oil, or oil with some anti-corrosion paint, not enough to make the ceiling at all rough. The moisture that condenses against the ceiling will have no chance to penetrate the plaster, and the drops, instead of falling on the beds, will run down the smooth ceiling to the side wall.

In our practice and observation we have met with a good many instances in which roofs of Mushroom houses nicely plastered have fallen piece by piece over the beds, because damp had acted on the plaster, and thence extended to and rotted the laths and rafters. It is sixteen or eighteen years since the ceiling of the roof of our lean-to house was brushed over with oil, and though it has looked rather dingy ever since, we believe that the roof is perfectly sound.

As stated above, our house is just a close lean-to shed behind a vinery, with a common 9-inch wall, a small brick ventilator at each end at the apex, and ventilation also in the outside wall. We have often had good Mushrooms in that house all the year round, but frequently in very hot weather in summer they would be thin, and would be soon attacked by maggots in spite of everything we could do, and very likely just when we wanted them to be particularly good. This led us years ago chiefly to depend for a summer supply on small beds in a shady shed, open on one side to the west. Here they gave good returns, and with little trouble. All sorts of places are used successfully for growing Mushrooms. For doing so all the year round, no place is better than a deep cool cellar, a cavern, or any place under ground, where a rather equable mild temperature is maintained all through the season. There is hardly any great advantage, however, which has not its counter-veiling disadvantage, as in the cellar, the cavern, &c., there is some trouble in taking the dung down and back again—more trouble than when a barrow can do all that is wanted. A correspondent wants a neat Mushroom house, that must be built in rather an exposed place, but so that company may go into it summer and winter. We would rather like some shade, and have a prejudice for a lean-to roof facing the north; yet we would not greatly object to an open position and a span-roof facing east and west, or even south and north, if deemed more suitable, provided we were allowed to have double walls, a double roof, and a confined body of air between such walls and roofs, so that even the ventilation should have no access to that confined air. Then, by painting or otherwise rendering the outside walls and roof as white as possible, we should have

a house that would never be very warm in summer or very cold in winter. In such a house artificial heat would be little needed, still it is a help when quick returns are wanted at times, and if the house were from 12 to 14 feet wide there would be room for a bed on each side, and a path of 3 feet wide in the centre, and that pathway of stone, slate, or gravel, could have a hot-water pipe on each side of it. If in the house one or two platforms should be deemed necessary, then to be in character the uprights and bearers should be of iron, and the bottoms and sides of slate. The house would always look neat, except when a bed was being made, and when shallow beds are used this might be too often to prevent, except to the interested, a Mushroom house being a show house.

Some small windows would be necessary, if merely for light, so that visitors should see the crops; the windows, too, had better be double, otherwise they might admit too much heat in summer. The question of light is rather too large as respects the Mushroom to be entered on here, farther than to state our conviction that Mushrooms grow as well in the dark as in the light, and that so grown they are as firm, sweet, and healthy, as those exposed to free light and air. We have no objection whatever to the light if it do not interfere with the desirable equal temperature; but no one need be afraid to use Mushroom-houses that never were exposed to a direct beam of light. With the requisite temperature of from about 70° in the bed, and from 55° to 60° in the atmosphere over it, even ventilation is of very little consequence, except to get rid of superfluous vapour when a new bed is being formed. It is in a close, muggy, warm night that the Mushroom grows most rapidly out of doors, and we can hardly err to take a lesson from Nature to guide us in our practice. It will only be by doing so that we shall succeed in cultivating other valuable fungi.—R. F.

PORTRAIT OF MR. RIVERS.

THE following subscriptions have been received, in addition to those already announced:—

	£	s.	d.
Ellison, Rev. C. C., Bracebridge Vicarage, Lincoln	1	0	0
Pennell, Mr. Charles, Lincoln	1	1	0
Walton, Mr., Camfield Gardens, Hatfield	0	5	0

ESSAYS ON FLORAL CRITICISM.—The prize offered by Lieut.-Col. Scott, R.E., Secretary to the Royal Horticultural Society, for the best Essay on Floral Criticism, has been awarded to Mr. Alfred Bradley, 8, Salisbury Road, Highgate Hill.

THE AMERICAN PEACH TRADE.

THE *New York Times* says, that in the season "every man, woman, and child luxuriates at a small expense in the most delicious fruit known to humanity." But the Peach of the southern counties of England is superior to the American, and Covent Garden Peaches are from four to eight and ten times as large as Washington market Peaches. New York draws its supply chiefly from Delaware, Maryland, and part of Pennsylvania. Most of the fruit is sent by railroad in through cars; in favourable weather it arrives in much better condition by water, but weather cannot be relied on. The supply which reached New York and Philadelphia last year exceeded four million baskets, a basket averaging 200 Peaches; but this year there is hardly half a crop, owing to an "eastern blight." The method of the Peach trade in New York in the season is this:—A trip to Jersey City about 1 A.M. will show a shabby-looking unwashed crowd awaiting the cars. As soon as they arrive, no time is lost in selling, and 100 000 baskets are gobbled up very quickly, in quantities varying from 50 to 500 baskets at a time, by middle men. Now comes the turn of the first-class retailers, who often spend 3 dols. to 5 dols. a basket for choice lots; then the grocers, a hard lot to nit, but good buyers, make a large hole in a consignment; after them come the apple women, pretty hard at driving a bargain, but profitable customers in the main. The shippers and preservers come in later, and generally get fruit cheap. The last customer is the worst—the huckster. Be Peaches ever so good or ever so rotten, he hides his time, and never misses a chance of pouncing on some unfortunate dealer mad with anger at being "stuck," and anxious to get back some of his money. Rarely, however, does this class of retailers get anything but the very worst article, or pay more than 75 cents. a basket for it. When it is considered, that on

a moderate computation there are over 10 000,000 dols. embarked in the Eastern Peach trade, the profit on which exceeds 35,000 dols. per annum to the growers, labourers, and mechanics of the region, nearly 250 000 dols. per annum to the New York commission houses, 1,400,000 dols. to the railroad and freight companies, and perhaps another 3 000,000 to the vendors in New York, an idea of the importance of the trade may be had.—(*American Gardener's Monthly*.)

FRUIT TREES FOR SMALL GARDENS.

THOUGH much obliged to Mr. Abbey for his articles on the above subject, I was glad to see the editorial comment on his calculations of prices and productiveness, for an acre of such trees as he refers to have never given me anything at all approaching to the return he would lead one to expect. What with frost and drought, winds and weevils, the £ s. d. of fact is a very different thing from the £ s. d. of theory; and Mr. Abbey will add much to his favours if he will say whether his conclusions have been arrived at by actual experiment with a strict cash account, or whether they are merely an inference from his great general knowledge of fruit culture.

Mr. Abbey certainly has a large margin in his estimated cost of trees—viz., Apples at 1s. 6d. each; for many large firms—for instance, Fisher & Holmes, of Sheffield, supply splendid trees at 5s. per dozen; and I am told by market gardeners that some firms offer their maiden plants at 2d. each; and even that price, a grower informs me, affords a good profit, the land being £6 per acre.

I have no desire to throw cold water on bush fruit-tree culture, quite the reverse; it is a source of increasing interest and pleasure; but cent. per cent. at the end of seven years is a result I have never seen nor expect to see; and if an income of £180 per annum could be educed so pleasantly from an acre of land in seven years, men would not so freely risk their necks in grubbing for diamonds at the Cape.—C. C. E.

CHATSWORTH.—No. 1.

GLORIOUS Chatsworth! the crown and pride of Derbyshire, the best and most enduring memorial of the genius of Sir Joseph Paxton, is one of those rare places where harmony of aspect everywhere prevails. The wide expanse of the park, which in its circumference of eleven miles embraces more of natural beauty than can be found in almost any other county, the lofty mountain from whose summit the hillside comes down with a majestic sweep into the valley, through which the bright Derwent has its course—now gliding smoothly along, and now brawling over beautiful cascades, its waters agitated by the masses of rock over which it descends seething and foaming with a pleasing cadence—the gentle eminences, and the magnificent trees—all these features are in fine keeping with the princely mansion, which occupies an important position overlooking much of the fine scenery surrounding it.

But it is to the gardens I must turn my attention, as belonging more to my peculiar province, and which are so worthy of the great master whose hand designed their principal features. From the grand conservatory down to the kitchen garden all is on a scale of magnificence, and every part is enriched with the choicest treasures of the vegetable kingdom. Many are the striking features which the gardens generally, and the pleasure grounds particularly present; each of these features is on so vast a scale that it is developed in the highest degree of excellence. Here noble deciduous trees display the full beauty of their magnificent proportions, and vast spreading branches sweep the closely-mown turf, and in grounds so extensive and so beautifully kept they have an air of dignity and refinement very different from that which they present when crowded together in groups or shut in among thickets of wild underwood.

The masses of rocks forming the rockery are so disposed as to cause one to fancy they are the result of some terrible convulsion of Nature; so boldly and wildly are they arranged, that it seems hardly possible that the hand of man could have scattered these mighty fragments with as much ease as though they were so many pebbles. These rocks occupy a considerable space, at some places standing out boldly in all the might of their rugged majesty, and at others partly concealed among the shrubs with which they are interspersed, and as walks wind among them one is enabled to thoroughly enjoy this curious

and interesting scene. Close by the rocks, near an immense block, so carefully balanced that a slight push causes it to revolve on its centre, is the model of a tree called the Weeping Willow, standing in a circular enclosure with a narrow entrance. This tree is undoubtedly more worthy of its name than any natural specimen, for by turning a valve it is made to shed a copious shower of water, as many an unwary tourist has discovered.

The grand conservatory is a magnificent structure, covering an acre of ground; it is 277 feet long by 123 wide, and the central transept is 67 feet high with a span of 70 feet. It is heated by hot water, which traverses six miles of pipes, and to these statistics may be added the interesting fact that upwards of 70,000 feet of glass were used in glazing the roofs. Entering from the north end under an elegant Grecian portico, a sight of rare magnificence presents itself. Along each side of the central walk there are Palms growing in all the wild freedom of Nature, with wide-spreading frondage, light, elegant, and exquisitely graceful; some, as in *Corypha australis*, springing from the ground, while others, as in *Corypha umbraclifera*, borne aloft on stems so smooth and hard as to appear more like columns of stone than living trunks. At one part of the building we come upon an avenue of Bananas so luxuriant as to quite shut in the path along each side of which they are growing; their great leaves bend gracefully, high overhead, so that one can enjoy the full beauty of their delicate texture, and fancy oneself really strolling in a tropical jungle, the huge vegetation of which probably attains as high a development here, and a more exquisite finish than it does in its native habitat; for here no winds obtain the mastery and lacerate this splendid mass of foliage, which, from its large size, must be peculiarly susceptible of injury, especially when so violently agitated as it must be by the terrific storms which at times rage near the equator. At another part is a thicket of Bamboo (*Bambusa arundinacea*), then one of Sugar Cane, Cinnamon trees, and *Papyrus antiquorum*, the Paper Plant of the ancients.

At one corner of the building a singular effect is produced by a group of Aloes with their spinous leaves of the deepest shade of green, and on the opposite side to these quaint-looking plants is a splendid fernery formed of rocks, among which grow in the wildest luxuriance a host of the most beautiful varieties of exotic Ferns. Steps winding among the rocks give access to the gallery which runs round the building, so that the Ferns may be closely inspected, and their full beauty thoroughly appreciated. Very different is the aspect of such a fernery from that of the ordinary Fern house with its formal flat stages and with the Ferns growing in pots. I do not, of course, suppose it to be possible for many gardens to have such a huge and costly mass of material for such a purpose, but surely it might be modified in such a way as to suit the capacity of the smallest house. I lay some stress upon this, because there can be no doubt that when Ferns are cultivated in so natural a manner they are not only more luxuriant in growth, but much more beautiful in appearance than they can ever be in pots, however well they may be arranged.

From the gallery we have a fine view of this splendid collection of tropical plants displaying themselves in all their varied beauty of form and colour—the elegant forms of the foliage gracefully springing up and mingling together so charmingly that each leaf serves to draw attention to its neighbour. The vast extent of the building, and the immense number of choice plants spread about it so lavishly, produce an effect of incomparable grace and magnificence.

Such a sight might very well content one, even if there were no other objects of interest to be seen, but this is merely one among many others, of which the fine span-roofed Orchid houses worthily rank high. The whole of the Orchids were in the finest order and condition. In the cool house, besides the Orchids, was a fine collection of *Sarracenia*s, *S. purpurea* and *psittacina* being especially good. The *Dendrobium*s were also very fine, as were some remarkable pans of *Miltonia spectabilis*, *Clowesii*, and *virginialis* in fine flower. Of other plants in this house worthy of notice I may select a fine *Lycaste Skinneri*, *Cologyna cristata* very fine, *Calanthe vestita*, *Calanthe Wallichi*, and beautiful plants of those fine Ferns *Gymnogramma peruviana* and *Gleichenia semivestita*. In the Mexican house were splendid pans of *Cattleya crispera superba*, a very fine *Vanda teres*, *Dendrobium densiflorum*, and a very good *Lomaria gibba*. This is one of the most popular of Ferns, and it certainly deserves its high position, for it is extremely useful.

In the East Indian house my attention was at once attracted

by the magnificent collection of *Vandas*; many of them must be fully 6 feet high, and all of them were in fine health. Another striking object in this house was a noble plant of *Nepenthes Rafflesiana*. The *Aërides* were also very fine, especially a beautiful plant of *snaviissimum* in flower; nor must I omit a *Platanopsis Schilleriana*, a *Calanthe Veitchii*, and a grand *Anthurium cordifolium*. I have named only very few specimens out of this splendid collection, but the whole of them were in a high state of health, and their cleanliness and beautiful arrangement betokened the exercise of great care and skill in their culture.

Of another range of four span-roofed houses, two contained *Azaleas*, another some flourishing *Heaths* and *Epacris*e, and the fourth a fine collection of stove plants. Here was an enormous *Eucharis amazonica* 5 feet in diameter, a striking plant of the dark-leaved *Dracena ferrea*, and a fine *Alsophila exalca*.

The plants in three other stoves were all in a creditable condition, but none of them call for special mention, excepting a magnificent plant of *Maranta Veitchii*, by far the finest specimen of it that I have seen.

A long corridor or glass case leading up to these houses was very interesting from the fine climbing plants clothing the back wall throughout its length. Many large plants of *Fuchsia*s were trained up the wall, with *Tea Roses*, *Azaleas*, *Acacias*, *Veronicas*, *Bruceansias*, *Solanum Capsicastrum*, *Clianthus puniceus*, *Camellias*, and such plants as *Eutaxia myrtifolia*, *Chorozems cordatum*, *Mimosa prostrata*, and a very fine *Citrus decumana* (the *Shaddock*), laden with large fruit. A novel and striking effect is produced halfway along the corridor, where there is an alcove in the back wall, on each side of which is a large plant of *Camellia reticulata*, and the alcove itself contains a magnificent *Camellia alba plena*, which, though it grows against the wall, does not present a flat surface like the others, but is so trained that the centre of the plant stands out some distance from the wall, and from this raised centre the branches are beautifully graduated backwards to the sides, which are close to the wall. High overhead a beautiful fringe of the flowers of *Fuchsia corymbiflora* hung pendant along the top of the alcove.

The orangery is 108 feet long and 27 wide—it is an apartment of *Chatsworth House*; it contains some fine *Orange* trees, many of which originally belonged to the collection of the *Empress Joséphine*, at *Malmaison*. A pair of huge white *Camellias* nearly 20 feet high, had beautiful healthy foliage and an abundance of flower-buds. Some very large *Rhododendrons*, a fine *Lomaria gibba*, a lofty *Asplenium fontanum*, a *Phyllocladus trichomanoides*, with its singular pendulous branches and many fine pyramidal *Camellias*, are the principal plants. Among the plants I noticed a beautiful marble copy of the *Medicean vase*, and a charming group of statuary of *Venus* and *Cupid* at play; but these sink into insignificance as one obtains a glimpse of the magnificent art treasures in the sculpture gallery, which opens into the orangery. Here are marble figures possessing all the graceful symmetry which the hands of such masters as *Canova*, *Gibson*, *Campbell*, *Schadow*, and many other famous artists could impart, and in the centre of the gallery is an immense vase of polished granite, known as the *Mecklenburgh vase*, which was cut out of a single block, and is 20 feet in circumference.

A broad flight of steps leads down from the orangery to a gravel walk, whence other steps ascend to the *Camellia* house. On each side of this walk was a broad ribbon border of nine rows arranged in the following order—1, *Cerastium tomentosum*; 2, blue *Lobelia*; 3, Golden *Pyrethrum*; 4, *Iresine Herbstitii*; 5, Flower of the Day *Pelargonium*; 6, *Pelargonium Christine*; 7, *Stella*; 8, *Cineraria maritima*; and 9, a purple *Pentstemon*. These were two very handsome borders. The plants were in full beauty, and the arrangement most satisfactory, with the exception of Flower of the Day, for which I would substitute Flower of Spring. One was puzzled at a little distance off to know what the *Pentstemon* could be, for its rich deep colour was very peculiar and attractive; it was just high enough to form a capital back row.

The principal masses of flowers are displayed in a series of raised beds with stone facings, which have a fine effect viewed from the terrace walk along the west front. The style of colouring was massive and very effective. The appearance of the whole of the beds was altogether good, for these raised beds seemed to me to possess an air of dignity very suitable for the important position they occupy; and what, perhaps, helps as much as anything to impart this is that they are so far apart that each is a complete and finished feature in itself.

Their large size, too, and the ample breadth of turf on which they stand, all add to their importance.

I must not conclude this part of my report without alluding to the renowned Emperor Fountain. From the south front a

fine vista opens out between masses of lofty trees to some of the hills in the distance; in the centre of the space between the trees up springs this noble fountain, a single jet of 260 feet high forming a glistening cone of falling spray, depending on

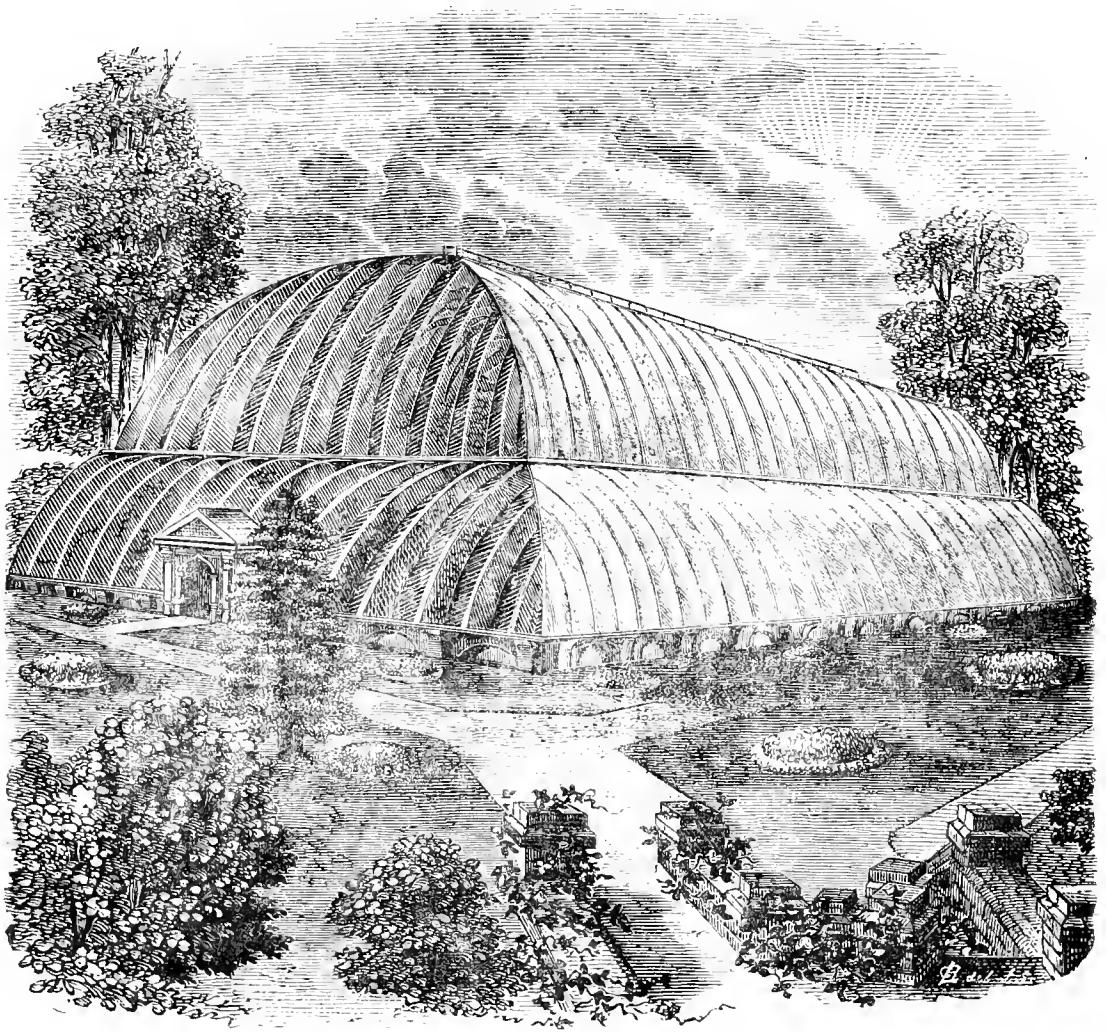

Conservatory at Chatsworth.

no statuary nor architectural accessories to add to its effect, but by its grand simplicity and mighty force alone it dazzles

and astonishes all who see it.—EDWARD LUCKHURST, *Old Lands, Buxted, Sussex.*

NEW BOOK.

Sea-side Walks of a Naturalist with his Children. By the Rev. W. HOUGHTON, &c. Groombridge & Sons.

THIS is one of that very useful class of books—popularly written yet accurate—composed by men of science who could write authoritatively on its deep things, yet who can descend to write alluringly for the young, like Faraday, who in the morning was tearing compounds into their elements by the galvanic power, and in the evening rivetting the attention of children by lecturing on a candle. One extract illustrative of Mr. Houghton's style must suffice:—

“‘Papa,’ said May, ‘there are some large stones near the water; do you not think we might find some Sea Anemones attached to these stones?’ Off we all scamper, and Jack very soon tells us he has discovered what he thinks must be a Sea-Anemone. At once I recognise the animal as a specimen of the common Smooth Anemone (*Actinia mesembryanthemum*); we will wait by this large stone and examine the creature. It is fixed by its broad fleshy base to this bit of rock, its numerous tentacles spread out in the little pool the tide has left; the

mouth is situated in the centre of the disc. I dare say we can tempt the creature to use it for our instruction. I will catch a small fish and offer it to the Anemone. See the tentacles have caught hold of it, and are bringing it to its mouth; in about two minutes the fish is swallowed.”

“Here is another Sea Anemone, a much finer specimen than the one Jack found. ‘Oh,’ said May, ‘it is a beautiful specimen; is it the same species?’ It is generally considered to be a variety of the other one; it is called the Strawberry Anemone, from its resemblance to the fruit of that name. If I touch its tentacles, it immediately closes itself up. These creatures have no eyes, yet are so susceptible of light, that they will often show they are aware of a passing cloud by shrinking. Should an unlucky crab, though stronger far apparently and much more active than the zoophyte, touch the expanded arms, activity and strength avail it little; with slow, but pertinacious and unflinching grasp, the *Actinia seizes* hold of it,

and soon involving all its limbs with the tentacula around the mouth, the victim is gradually dragged into the polyp's stomach, there to perish. All its softer parts, all that can be nutritious, is digested and dissolved, until at length the Actinia, being satisfied with its abundant meal, opens again its mouth, and then regurgitates the shell and what is indigestible. Nor does a little food suffice to satisfy its appetite. The Actinia is voracious, harmless and flower-like though it seems; sometimes, for instance, it will swallow whole three or four mussels for a breakfast, and dissolve them all except the shells. Mr. Gosse calls this species the 'beadlet,' from its possessing a number of blue bead-like tubercles around its mouth. The scientific name of Actinia is from a Greek word, meaning 'a ray,' in allusion to the tentacles. This is a very variable species as to colour, and the commonest of all the Sea Anemone family. The Actiniae resemble their relatives the Hydræ, in their power of reproducing lost portions of their bodies. If

one be cut in two with a sharp knife or razor, each half will grow to a whole animal."

We wish to arouse more attention to the marine aquarium, and, therefore, will republish the following which appeared in our columns about twelve years since:—

"In the subjoined cut are represented four of the best Sea Anemones, whether for a beginner or an adept. In the richest collection the common 'Mes,' or *Actinia mesembryanthemum*, is as valuable as the rarest, on account of its intrinsic beauty; and as to hardiness and longevity, no creature of the deep ever yet brought within domesticating influences, can equal it. When all goes wrong, and the pretty creatures drop from their stony pinnacles and perish;—when the water gets putrid, and, perhaps, half a dozen degrees of specific gravity too dense—'Mes' will still be found alive and unhurt, and will display its coral fingers and bright blue beads the moment he is lifted into a purer element. This is known by many popular names, of

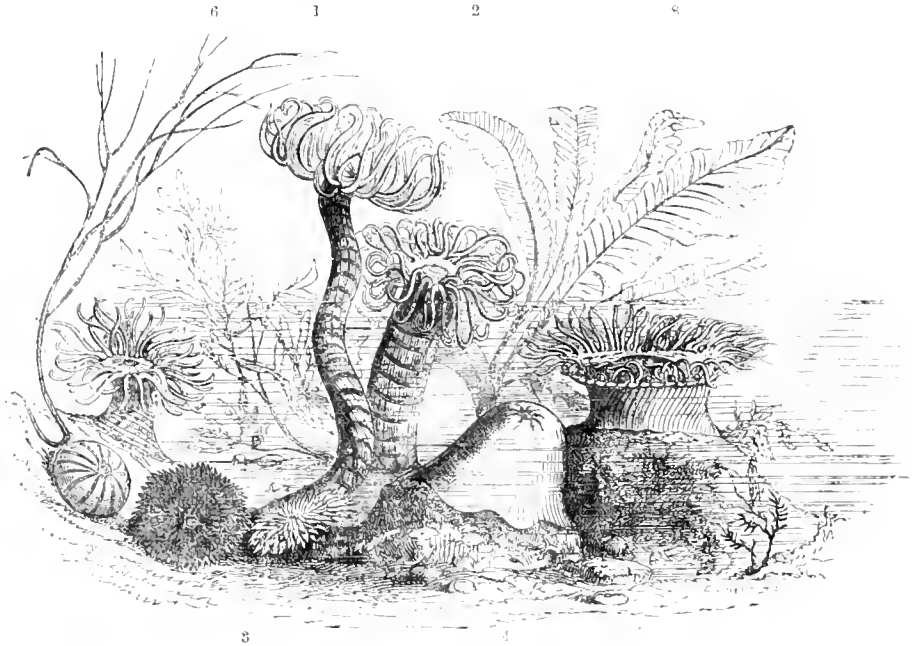

which the most common is 'Strawberry Anemone,' for the most plentiful form of it is that which strongly resembles, when closed, a well-grown Sir Harry. But it has so many varieties, that for mere effect this species is, in itself, sufficient for a small tank. In its most common form it is spotted on a crimson ground, Strawberry fashion; in another it is of a deep maroon, without spots. There is another variety of a deep quiet chestnut; another of a dark olive green, and a rarer and exquisitely beautiful one of a very bright, almost grass green.

"The numbers on the cut refer to the specimens as follows:

—1, 2, 3, *Sagartia anguicomma*, or snaky-locked Anemone, in three different states, the last being shrunk up; 4, *Bunodes clavata* in its ordinary force of expansion; 5, the common 'Mes' expanded, and closed; the row of heads resembling torquises which surrounds the tentacles, is peculiar to this species, and adds vastly to its beauty, especially in the rose and coral-coloured specimens; 7, *Actinia bellis*, the sea Daisy; 8, the lovely red *Alga*, *Delesseria sanguinea*, drawn from a very fine specimen; the plant on the other side is *Furcellaria fastigiata*; 6, one of the few purple *Alge* that may be preserved in small collections."

WORK FOR THE WEEK.

KITCHEN GARDEN.

VARIOUS are the schemes of rotation practised by different gardeners, many of them being based on no better foundation than the convenience of the hour; where, however, the kitchen garden is sufficiently extensive, and where much produce is required, the rotation of crops should be carefully studied. Calendrical limits will not permit me to offer more than a few words of advice, which, however, will, as far as they go, be a tolerably safe guide. The great difficulty is to procure fresh ground for the Cabbage tribe, so numerous are the kinds as well as successions in cultivation. Broken-up plantations of Strawberries, Raspberries, and bush fruit, with Celery ground, should at all times, as a leading principle, be set apart for some of the Cabbage family. The ground from which Celery has been grown, especially in the Scotch or bed fashion, is also

ready-made ground for new Asparagus beds. Potatoes prepare well for almost every crop. Deep or tap-rooted crops should be succeeded by shallow or fibrous-rooted ones. When the course of cropping has been decided on for the ensuing year, and duly entered with numbers in the garden book, the practice is to set up laths opposite to the space appropriated to each crop, with the number corresponding with the book, and the name of the crop on one side, and on the other the manure, where from, and the quantity, with the mode of cultivation—digging or trenching. This done, a labourer who can read the label can set out or proceed with the work at any spare time. Winter has at last commenced, and it behoves every one possessing a garden to cast his eyes once more round in order to see whether its rigours can be further softened with regard to anything tender. An opportunity will now occur of covering

the roots of *Asparagus* with a good coat of the best rotten manure. Hard frosts frequently do serious injury to this root from want of such covering. The Celery ground, as before observed, will answer well for a new plantation; it should be ridged to mellow as the crop is taken up. Cover *Endive* plants with a slate or tile laid on each side, and cover the whole with dry leaves, finishing with some stable litter; in this way they will blanch well and be fit for use throughout the winter. The best policy with *Lettuces* intended for supply next spring is to allow them to freeze tolerably firmly before covering them up. A very light screen of straw should be shaken over them at first, and when this is frozen add a little more, the object being to keep them frozen as long as possible; above all, do not uncover them when a thaw arrives; let them remain until completely thawed. These remarks will bear equally on all other vegetables of a tender character. On dry, well-drained ground on a south aspect, a sowing of Peas may now be made. The Double-Blossomed Early Frame is the most profitable for this purpose; Prince Albert is earlier, but is apt to suffer much from cold winds and wet, and succeeds better when started in heat and transplanted in February. Where there are not pits adapted for forcing *Sea-kale* and *Rhubarb*, let a quantity of each be covered over with pots or wooden boxes, or hooped over with rods, and have fermenting material placed round them—leaves are preferable to any other, and by covering them with some long stable dung, they are prevented from being blown about the garden. It is beneficial to water the soil in which the plants to be forced are growing with water heated to 130°, covering the ground immediately with leaves.

FRUIT GARDEN.

Fig trees must now have some dry Fern or Spruce boughs nailed over them to prevent injury from severe frost, though damage is less likely to occur this season, as, from the fine warm summer we have had, the wood of every description of tree is well ripened, and consequently will resist the effects of severe weather with impunity, whereas, if ill-matured it would suffer severely. If I dared to prophesy I should say that next season would be more than usually abundant in fruit of all sorts.

FLOWER GARDEN.

The late slight frosts will have brought vegetation generally to a state of inactivity, and finally destroyed the lingering floral beauty of the declining year. Let, therefore, the clearing-off of the decaying stems be at once proceeded with, as also the general removal of the fallen leaves. In this uncertain climate it is all-important to have a reserve of protecting material at hand in case of need, but it is best not to apply it till there be some indications of severe weather. If we protect carefully and the season prove mild and growing we may do harm. Complete all planting, and forward all alterations, particularly the removal of objectionable trees, which, if cut down now, may be taken away in frosty mornings without much damage to the turf and walks. Now that the flowers have departed it will be necessary to endeavour to compensate for their absence by the perfect order and neatness of the surface of the garden, the gravel, the turf, and the soil. It is advisable to keep all Carnations and Pinks which may have been potted during the past month from the action of frost, as they are unable to withstand it so well as those which have established themselves from being potted earlier in the season. They should not, however, be shut down when damp, for though extremely hardy, no flower suffers so much from want of a free circulation of air as the Carnation. Tulip beds, as a matter of course, have been covered as previously directed. The lesson taught to florists generally last season will not soon be forgotten, and from the loss then sustained I anticipate greater attention will be paid to protection for the future. It is a good plan to place young shoots of Gorse between the rows of Pinks where rabbits are apt to come, and it will prevent cats from taking liberties with the beds, independently of protecting the plants from the cutting winds of the winter months. Look well to the turning of compost heaps, &c.

GREENHOUSE AND CONSERVATORY.

The Camellias will now be making a fine display in the conservatory; they should receive careful attention as to watering with very weak tepid liquid manure. Let them not, however, receive a drop until they are really dry, and then supply them liberally. If in such cases any air bubbles arise, continue to fill up with water until they cease. Let not a drop of water bespilled on the conservatory floor at this period, and keep on a very little air at back all night in order to let atmospheric humidity pass off.

Be very cautious in the use of fire heat, the less the better if 45° to 50° can be secured. In the greenhouse, see that the early-flowering Cinerarias have the lightest place in the house, close to the glass; crowding is very prejudicial to this plant. Let plants of *Eranthemum pulchellum* coming in bloom have abundance of water and a warm situation. The *Veltheimias*, *Tritonias*, *Stenolynchus speciosus*, *Lachenalias*, &c., are delightful winter plants; see that they receive due attention. Follow up the directions for the conservatory as to heat and general management.

FORCING PIT.

This structure will now daily become of increasing interest. Early-prepared forcing kinds of Geraniums should be at once introduced into the most airy situation, or on shelves near the glass. Plants of the beautiful kinds of Azalea indica in variety, which have also been well prepared, and have made early sturdy growth, and formed abundance of strong, plump, well-set flower buds, with *Rhododendron* in variety, *Ledums*, *Kalmias*, *Roses*, a few *Pinks*, *Wallflowers*, and bulbs in variety may be placed in succession in a gentle kindly bottom heat, afforded either by means of a tank or prepared fermented material, and moderate syringings with tepid water applied on suitable occasions. Fire heat should be principally applied by day, with a good portion of air. The pit should be shut up early, and night heat applied very cautiously indeed at this season, and still reduce its amount as the solar light decreases. Apply frequent but very moderate fumes of tobacco smoke to destroy the aphid; and slight applications of sulphur vivum liquid to the heating apparatus when nearly cold prevent the attacks of the red spider. Syringe occasionally with well-prepared clarified liquid from chimney soot, to be applied on the principle of "little and often."—W. KEANE.

DOINGS OF THE LAST WEEK.

KITCHEN GARDEN.

In wet days looked over roots, as Potatoes, Carrots, &c., and found all in good order. Shed room is of great importance, especially for seedling Potatoes, that they may be spread out thinly. Other roots may be built in banks, with dry soil or small dry twigs between the layers.

A few fine deep-coloured Beet leaves are useful for decorating flower-vases. We are less likely to think of the fine purple leaves being connected with the salad at this season than in the summer time. We have seen rows of deep crimson dwarf Beet far more beautiful than *Peilla* or *Amaranthus*, or even *Iresine*; and where ground is scarce the double purpose of decoration and utility may thus be served, though we confess to a prejudice against using Beet, or the finest variegated Scotch Kale or Borecole in the flower garden. One advantage of the latter is that they lift well with good balls, and as they do not show their colour thoroughly until late in the autumn, they are thus better fitted for moving to make a show in prominent places in the winter months.

The mention of these variegated Kales leads us to notice a prejudice against their use for culinary purposes, as several friends have told us that they are more difficult to boil, are harder when boiled than the green varieties, and that generally when boiled they lose their distinctive colour and become of a dirty sickly yellow. We cannot tell how this can be. In boiling them ourselves we have never used anything but a little carbonate of soda in the water, and in almost every case the white, purple, and crimson variegated Kales keep their colour, and are quite as sweet and tender as the best sprouts of the dwarf Cabbaging Kale. We think all Kales and Cabbages boil softest when put into boiling water. We have known fine vegetables made neither pleasant to look at nor pleasant to eat from being left to soak in merely warm water. Boiling in cookery is but little understood among the humblest, who ought to be best acquainted with it. We knew of a case some time ago where some very strong mutton broth was desirable, but considering the meat used the broth was very poor. The meat was put in when the liquid was boiling furiously. If to boil the meat and keep as much as possible of its good properties from going into the water, then the plan adopted was correct, but quite the reverse when soup or broth was the chief object. The very best vegetables are anything but attractive when spoiled in the cooking. The variegated Kales, when they keep their colour, make a nice variety on the table, and the white-variegated we have often found as delicate and good as Sea-kale.

On a dry day we gathered *Asparagus* seed before clearing the

haulm away. We took up Sea-kale and Rhubarb for forcing, and as Globe Artichokes have grown more than usual, owing to the heat of the summer and the mildness of the first part of the winter, we put some litter round the stools to save them from frost, and if frost should be severe, we have some laurel branches close at hand to stick in round the stools, as the tender growth will make them all the more sensitive to severe cold, and where such things are much run upon a scarcity cannot be easily got over. Pricked-out lots of Lettuces and even Endive, in beds, and at the front of fences, as the trouble is little, and if they stand they will be useful when the warm days of spring and early summer come. Those sown late are looking well, just a little too well, from growing rather much. It is well to have some of these growing thickly under a little protection in case the weather should be severe. We have often found little plants turned out now in soil just surface-pricked over, and a little dry a-hes, or burnt earth, or charcoal-dust sprinkled among them, do better than plants pricked out a month or six weeks ago.

FRUIT GARDEN.

We must refer the reader to what was said in previous weeks as to root-pruning, pruning, planting, top-mulching, &c. We should have been pruning and planting but for a prose of other work. Leaves now fallen from fruit trees in borders should be cleared up or pointed in, to prevent their blowing about. It is impossible to prevent for some time these signs of decay meeting the eye at every turn. You may sweep and roll walks and lawns, but ere long the winds will bring lots of tree leaves, so that until they are all down frequent sweeping is like washing a negro to make him white. Still, in all principal places leaves should be frequently picked up, as to some minds that revel in the beauty of the autumnal tints of the foliage the drifting and fallen leaves always cause melancholy.

We would like to impress on those who resort to root-pruning fruit trees now, in order to make those that are growing too luxuriantly more fruitful for the future, that root-pruning now, whether it is slight or rather extensive, though it will tell on the more stunted growth, will not increase the fertility in the following season. No pruning at the root now will make a fruit bud more mature, or turn a wood bud into a fruit bud. This must be waited for until the summer of 1872. When root-pruning is performed to affect the fertility of the next season it should be so done that the sun of September and October will act on the wood and buds, curtailed of the previous supply of crude sap. With shallow planting and surface-dressing, root-pruning and root-lifting may be reduced to a minimum; though facts tend to prove that many of the finer sorts of Apples and Pears, for instance, that will not grow healthily, nor produce good fruit in unfavourable circumstances, will do both when the trees are kept small and a mass of buds, by frequently lifting and replanting. The summer sun has then more power to thoroughly mature the buds and consolidate the wood. Where the Ribston Pippin could hardly live for canker, even when planted carefully, it has become healthy when the growth was limited by frequent re-budding or root-pruning. We may mention here that the Margil Apple, a miniature Ribston, will often thrive and bear heavily where the Ribston Pippin would hardly live without root-pruning.

ORNAMENTAL DEPARTMENT.

Mowed for the last time, we trust, this season some outlying parts of the pleasure grounds, that grass and leaves may be swept up together. Such material, and especially tree leaves, will be valuable at all times, and more particularly now, for giving a help to many things in the way of bottom heat. One great advantage of tree leaves when thus collected a little damp is that they heat quickly, but the vapour from them is so sweet that it will never injure the most tender plant; so different in this respect from the fumes of fermenting dung before it becomes sweet. When we use dung in rather a rank estate we like to have from 6 inches of these sweet leaves over it, as thus they will arrest all the noxious vapours and prevent them tainting the atmosphere. Let us say, however, to beginners that in using tree leaves, so as to obtain a genial heat from them in a bed or house, it is advisable to let them heat well in a heap first, as such a heat either kills or drives away myriads of small elugs and snails, which otherwise might make great havoc. Decayed leaves, as sweet leaf mould, are so useful that no one with a garden can save leaves with too much care. When intended to be kept for future use for heating purposes they can hardly be collected too dry. For present use it is of no importance though they be damp, and

any grass that may be raked up with them will not at this season make the heat too rank for immediate use.

As just stated, a few leaves will disfigure the finest green-carpet lawn. It is often a good plan to pick these up by hand and place them in a bag or apron. We have seen lawns swept over to get a handful of leaves, when each leaf could have been picked up in a tithe of the time. Of course, when numerous, the broom should be used, but unless very thick no heap should ever be made, nor much ever kept before the broom. After this season the roller is the best friend to the lawn, making all smooth, and keeping wormcasts out of sight.

With planting, ground work, turfing, &c., we shall be busy. The last if done now will give no trouble afterwards. For houses, pot plants, &c., we must refer to recent notices.—R. F.

TRADE CATALOGUES RECEIVED.

P. J. Perry, The Nurseries, Banbury.—*Catalogue of Ornamental Trees, Hardy Shrubs, Conifers, Fruit Trees, &c.*
George Edwards, 1, King Street, Castlegate, York.—*Catalogue of Roses, Fruit Trees, Pelargoniums, Carnations and Picotees.*

TO CORRESPONDENTS.

* * * We request that no one will write privately to any of the correspondents of the "Journal of Horticulture, Cottage Gardener, and Country Gentleman." By doing so they are subjected to unjustifiable trouble and expense. All communications should therefore be addressed solely to *The Editors of the Journal of Horticulture, &c., 171, Fleet Street, London, E.C.*

N.B.—Many questions must remain unanswered until next week.

LOOKS (*A Subscriber*).—"The Cottage Gardeners' Dictionary," gives the names, nature, and culture of plants of all kinds. (*J. B. Boyd*).—"The Orchid Manual;" you can have it post free from our office, if you enclose thirty-two stamps, with your address. (*R. Lamb*).—We do not know the book you mention. Mr. O'Donnell's notes we are now publishing in this Journal, will contain what you seem to need.

JOURNAL OF HORTICULTURE (*A. L.*).—It is published to monthly parts as well as in weekly numbers.

DISCORDANT THERMOMETERS (*Tyro*).—You ought to have no such discordance (four thermometers all registering differently, one as much as 8 from another), as you paid good prices for them. Your best resource is to send them to Kew Observatory, enclosing 1s. for each. They will be returned rectified.

GARDEN PLOTTING (*M. E.*).—Apply to Mr. Gibson, jun., 29, Eridge Road West, Battersca, S.W.

GARDEN MATTING WHOLESALE (*Agent*).—Apply to Messrs. Murray and Paterson, 46, Cbnrth Street, Minorities, E.C.

BRICKS (*Self-help*).—A brick is 9 inches long, 4½ inches wide, and 2½ inches thick, and as there are five hundred bricks in a load, you can easily calculate how many loads you will require to build the wall. You must allow some over for breakage and waste. "The Gardener's Year Book" for 1871, gives full information on the subject.

FUELLESS STOVE (*A. G.*).—No stove that could be devised, no fuel, whether coke, charcoal, gas, oil, or paraffin, unless the fumes produced by their combustion are conveyed away by a flue, can be employed among plants without injuring them.

PARADISE PIPPIN (*A. Q.*).—The Paradise Pippin is not a bad bearer, and is not generally long before it comes into bearing. Your tree on the Crab stock is probably in good soil, and too closely pruned. This will induce the formation of wood, notwithstanding the root-pruning you have subjected the tree to. The variety is not of such excellence that you need inconvenience yourself with it. Let the tree have more play, and perhaps it will do better.

APPLE PIPS SOWING (*Andrew Robertson*).—To keep the Apple pips fresh till the spring, leave them in the fruit; or, if this should decay, mix some sand with them, and in March sow the pips either in pots or pans if the quantity is small, or in the open ground in ordinary garden soil if there is a large quantity of them. We think Golden Leadington a good name for the large Apple. It is well worth propagating.

BUDDING CAMELLIAS ON ORANGE AND LEMON-TREE STOCKS (*C. J. S.*).—Budding or grafting Camellias on Orange or Lemon stocks is not likely to prove successful. Why not graft the stocks with Orange and Lemon scions? They would then give you both flowers and fruit.

SOWING TOM THUMB TROPEOLUM SEEDS (*Idem*).—Now is not a good time to sow the seed, and, indeed, it would be useless doing so, as the plants are more tender than Geraniums. March is quite soon enough to sow the seed out of doors. The *Viola cornuta* we would not sow until February, and then in pots or pans in the greenhouse.

RIVERS' VICTORIA NECTARINE AND PRINCESS OF WALES PEACH (*C. R.*).—Though a horse with fire heat is considered to improve the flavour, we have known them grown fine in a cool house, and that we consider is all they require.

GRAPES RIPENING IN A VINERY WITHOUT FIRE HEAT (*Idem*).—Of the kinds you name, Gros Colmar, Lady Downe's, and Black Muscat of Alexandria require fire heat; the others will do in an ordinary vinery.

EVERGREEN FOR SCREEN (*W. B.*).—The Austrian Pine is the hardest and quickest-growing evergreen tree we know; but to have an effectual screen of it you will need two rows instead of one. American Arbor-Vitæ is a quick, close-growing evergreen, that would serve your purpose, only you will need to get large plants to begin with, or wait a considerable time, and if the place be much exposed there is a danger of the tops being

destroyed after the shoots overlap the wall. It is, however, very hardy. You may safely plant it when 6 or 8 feet high, and it should not be more than 3 feet apart. They need no attention beyond planting now or early in March, watering during dry weather in summer.

SELECT TEA-SCENTED ROSES FOR OUT-DOOR CULTURE.—Gloire de Dijon, Abri-côté, Vicomtesse de Cazes, Devoniensis, Adam, La Boule d'Or, Madame Levet, Janne d'Or, Belle Lyonnaise, Adrienne Christophe, Monplaisir, and Madame Damazin. Kenne's "In-door Gardening" will suit you for the management of the greenhouse; and for florists' flowers, "Florists' Flowers for the Many." The former can be had post free from our office for twenty postage stamps, and the latter for 4jd.

PLANT FOR COVERING A SLOPING SOUTH-WEST BOWER (A. Z.).—Plant *Cotoneaster microphylla*. Ivy is very fine for such purposes, but in our opinion does not equal the *Cotoneaster*, which has pretty white flowers in May, followed by bright red berries in autumn, and it is of close dwarf growth. The irregular growths should be removed in August.

DISA GRANDIFLORA NOT THRIVING (J. G.).—We think your plant is becoming unhealthy. We should advise you at once examining the soil, and if that is at all saturated or sour replace it with fresh, and let the drainage be thoroughly effective. Water carefully, but keep the soil regularly moist. It is well to set the pot in a saucer of water, raising the pot on three pieces of sandstone. At this season the water should not reach the pot. A cool airy greenhouse is the most suitable position; the temperature ought not to fall much below 45°. Spring is the best time to shift the plant into a larger pot. We think your plant is suffering from want of heat. Avoid a close atmosphere.

OAK-LEAVED PELARGONIUM LEAVES YELLOW (Yellow Oak Leaves).—The present condition of the plants is probably due to the great heat to which you are subjecting them; 50 to 60° is quite hot enough for a stove. The old leaves that are bronzed now will soon fall, the heat having caused their ripening; and the golden colour, which we presume is on the young leaves, is caused by their growing so quickly at this unnatural season. Probably they will come to their natural colour when placed in a light airy position in a house with a temperature of 40 to 45°. The old leaves, however, will all fall.

TRANSPLANTING VINES (J.).—It is not too late for removing your Vines. We have not found the fruits sent. Are you sure they were left at our office?

TRAINING VINES (M. H.).—Your proposed plan will answer very well. You might take a part crop from the top part of the two Frontignans the first year or two, until the new rods from the Black Prince became strong enough. You might also utilize the stems of the Frontignans, if you thought proper, by grafting the other young shoots on them. We have no doubt the rods will soon be strong enough without that trouble. It is seldom that the White Frontignan shrivels up. It is, though small, one of the best-flavoured Grapes, and a free bearer.

MOVING VINES (M. H.).—The Vines planted twelve years ago may be removed, but we do not advise your doing so. It is better to plant young Vines, which will be better and come into bearing nearly as soon as those which are lifted. The best time to lift them is early in March, taking them up carefully and covering the roots with mats to protect them from sun and wind. In planting spread out the roots carefully. No shortening of the Vines is necessary beyond the usual pruning, which ought to be done in December. The best compost for Vines is the top 2 or 3 inches of an old pasture where the soil is a good light loam; that of chopped up rather roughly nine cartloads, old lime rubbish one cart-load, eight bushels of half-inch bones, a like quantity of charcoal as lumpy as possible, and two bushels of calcined oyster shells, the whole well mixed. The sods are best used fresh. The Vines will not fruit next season.

VINES (J. Mackenzie, M.D.).—All the Vines you mention, with the exception of Chasselas Vibert, Furtado, and Royal Ascot, require a high temperature. These will do in a house with the heat ordinarily given to the Black Hamburg. The foliage of Mrs. Pince is deeply and finely cut.

VINES WITH ENDS GROWING (G. F. B.).—In your case, as you must cut the rods of your Vines back, we would either remove the part of the ends with green leaves now, or take away the leaves. The wood, we have no doubt, is ripe enough, and a period of comparative rest will suit the Vines now. As to keeping plants in the house, see note in page 412. Clear lime water is the best thing you can use, and the safest means you can try for dislodging worms from pots plants. If you cork-up the drain-hole for a few hours and saturate the soil, the application will be more effectual. Do not, however, allow the cork to remain.

MANURING VINES (M. B.).—Vines with their roots entirely inside the house need manuring, and it is best given as surface-dressing. We would use an inch of your poultry-yard manure all over now, and when that is pretty well washed in, by the early part of the summer, you could add a little more. If the roots are all inside, they will have no watering except what you give them. If the soil is rather dry now and you mean to start in December, we would use water at from 61° to 70° in temperature.

DESTROYING FAIRY RINGS ON LAWNS (C. H.).—See No. 499, October 20th, page 315.

SELECT POTATOES AND THEIR CULTURE (One wishing to improve himself and others).—Four varieties of Kidney Potatoes—Ashleaf, Rivers's Royal, Veitch's Improved, and Myatt's Prolific are good varieties; Lapstone, Milky White, and Berkshire Kidney; and of Round—Early Oxford, Dalmahoy, Flour Ball, and Bovinia for size, though it is inferior to Victoria. Your soil being very stiff we advise your manning it at once, and having it deeply turned up, and as roughly as possible, for the winter. The mixing with road scrapings would be advantageous. We would not give the dressing of bone dust until planting time, and then you may sow it broadcast. It is good, but for Potatoes we consider Peruvian guano preferable, 2 to 3 cwt. per acre being a good dressing.

LICUID MANURE FOR GERANIUMS AND CAMELLIAS (Idem).—Guano water is beneficial to any kind of plants needing vigour; it should be given of the strength of 2 ozs. to the gallon once or twice a week. At this season, however, it is not required. For Camellias swelling their buds, liquid manure formed of sheep's droppings is best—one peck to 30 gallons of water; cowdung, one peck to 20 gallons of water answers well.

COMPOST FOR MRS. POLLOCK GERANIUM (Agnes).—When it can be had fresh loam from turf is undoubtedly the best compost when enriched

with a fourth of well-rotted manure, adding a sixth of silver sand. To your strong loam add one-fourth of leaf soil, and a like quantity of sharp sand. This compost, with good drainage ought to grow them well. The most likely cause of the greenhouse *Pelargoniums* having but few flowers in a truss is weakness, which may be a result of poor soil, and quite as likely of a weak growth occasioned by growing them too far from the glass, and not giving a sufficient amount of air. They can hardly have too much air and light.

EUCHARIAS AMAZONICA (B. P.).—By plunging the pots in a brisk bottom heat it is likely they would start for flower or throw out flower scapes, but the flowering will be entirely dependant on the previous treatment. The essentials are to give the plants plenty of heat, and an abundant supply of water and moisture when making new growths, and then place them in a light airy position, but in a good heat, giving no more water than is useful to keep the leaves from flagging. This treatment continued for three or four months, and the plants then returned to bottom heat and moisture, will generally ensure a good bloom; but keeping them constantly growing seldom results in anything but the production of leaves. To have Strawberries ripe at the end of March, forcing should be commenced early in January, and the plants should now be under cover in a cold frame or cool house.

VALVE OF HOT-WATER PIPES (H.).—We do not think it matters whether the valve in your pipes is on the level or between two pipes, the one perpendicular to the other, or in a slanting direction, provided no impediment is given to the free circulation. Valves are chiefly necessary for flow-pipes to different places, leaving the returns to look after themselves.

NAMES OF FRUITS (C. R.).—1, Winter Greening; 2, Vicar of Winkfield; 3, Devonshire Buckland; 4, Ghou Morcau; 5, Chester Pearmain; 6, Old Colmar; 7, Robinson's Pippin; 10, Downton Pippin. (A. S. D. H.).—Pears—1, Meuris Permain; 2, Princess Charlotte; 3, Lewis; 5, Ne Plus Meuris; 6, Beurre Dufais; 7, Old Colmar; 8, Worm-ley Grange. Apples—1, Toker's Incomparable; 2, Waltham Abbey Seedling; 3, Herefordshire Pearmain; 4, Golden Winter Pearmain; 5, Golden Reinette; 6, Court-pendu plat; 7, Reinette Frauche; 8, Orange's Pearmain. (F. J.). 1, Margit; 2, Golden Nonpareil; 4, Braedick's Nonpareil; 5, Golden Russet; 6, Fasse Colmar. (John J. Harper).—Golden Russet.

POULTRY, BEE, AND PIGEON CHRONICLE.

BIRMINGHAM POULTRY AND PIGEON SHOW.

THIS, the twenty-second Exhibition, was superior in numbers of poultry, but inferior in numbers of Pigeons, to its predecessor. It commenced on the 26th of November, and concludes to-day. In quality, though there were some grand exceptions, the birds were much inferior to those of last year. There were 1971 entries of poultry last year, and 2125 this year; 482 entries of Pigeons last year, and 453 this year.

The following is a comparative statement of the entries in this and last year:—

	1869.	1870.		1869.	1870.
Dorking	331	294	Other distinct breeds..	23	12
Spanish	79	72	Game	396	374
Cochin-China	260	323	Bantams	142	174
Brahma Poutra	233	261	Ducks	116	120
Mohay	18	27	Geese	34	36
Crève-Cœur, Houdan, and La Fleche	97	107	Turkeys	50	67
Hamburg	181	195	Pigeons	482	453
Polish Fowl	56	63		2453	2578

The first-prize Rouen Ducks were again heavier than the Aylesbury, the drake and Duck weighing 19½ lbs., being 6 ozs. more than last year. Mrs. Seamons's prize Goose and gander weighed 62½ lbs., just 5 lbs. heavier than the heaviest last year. But America whipped us in Turkeys, Mr. Simpson's bird, of New York, weighing 36½ lbs., which was just 1 lb. 2 ozs. heavier than the second-prize cock belonging to Mr. F. Lythall. The heaviest last year weighed 34½ lbs.

DORKINGS.

1. The old Grey cocks numbered twenty-two, exactly the same as last year. Mrs. Arkwright came first with a grand old cock, weighing 13 lbs.; he had one foot deformed, but in spite of this fault no other bird came near him. The second prize was a very fine dark bird, with good legs. Third prize a very dark cock, with a good body, but very bad feet and toes. Fourth prize a fair average bird, but out of condition. The last entry in the class (22) was a bird of fine frame, but very tender on the feet; indeed, nearly all the class seemed much afflicted in this way, and, except the prize birds, very moderate in quality.

2. The cap cockerel was a very neat bird with remarkably perfect feet, but would not have been large even for a Silver-Grey; he was only entered at three guineas, and the award was generally thought an error. Second prize a fair, good bird, but toes rather faulty. Third also a good bird with imperfect feet. Fourth prize deserved the position well, and ought perhaps to have been higher. Fifth prize a fine-framed bird, but one foot very bad indeed. We liked the sixth prize much better, and thought it more deserving than the cap bird. The greatest error in this class, however, was in passing over (34) a beautiful bird every way, and which ought to have had at least the second prize, if not the cap. This was a good class.

3. The first prize here were a grand pen, good in frame, legs, and feet. The second prize scarcely deserved the honour, one hen having

feet very much deformed. Third prize a good pair every way, and well placed. Fourth very middling, not nearly so good as pen 122. The fifth prize we liked far better than the second. This class was moderately good, and we thought darkness of colour seemed to have governed the awards a good deal.

4. The cup pullets, a noble pen, and in their place; one pullet perhaps a little down in the fifth toe, but hardly any other fault could be found. Second prize a good pen, but not so good as several others, particularly pen 157. The third prize contained one remarkably fine bird, but the other far too weedy for a prize pen. The same may be said of the fourth, which we thought better of than the third, one bird being unusually fine. Fifth prize were also very unequal in both size and quality, or most have been higher, and the same may be said of the sixth prize. Indeed there were grand single pullets all through the class, but except the cup pen there was hardly a pullet good year to be seen.

5. The first and second Silver-Gray cocks were good birds and well judged, regular Dorking frames, and much style. The third good in size and colour, but both feet in a frightful state. The fourth had a deal of white in the throat, and several specks on the breast; the next pen (228) we thought better of. The fifth a pretty bird, with good feet but yellow. Pen 216 contained a beautiful and large bird, and most have been second but for some white mottling on the breast; as it was we fancied him better than the fourth. On the whole this was a fair class, but several of the birds had no business in it.

6. The pullets we thought not nearly so good as last year. First prize a very nice pen, and deserving the honour. Third prize, a pen of good average excellence; also fifth; but we should have made the second and fourth prize exchange positions, the fourth prize being much finer.

7. The first prize White cock was a really grand one. Second also good, and but for a rather fanly comb would have run the other hard for place. Third prize very handsome and stylish, but rather wanting in substance. Pen 264 contained a massive bird, but with imperfect feet, which probably kept him from displacing the third prize. This class showed much progress.

8. The prize White hens were good birds, and correctly placed, but the rest of the class was far from equal to the cocks.

COCHINS.

9. The Buff cocks did not answer our expectation. The cup was a fine massive dark bird, rather clumsy, but a little mealy in the quills of his wings. Second prize and third prize much better in shape and colour, but smaller, and the third prize scaly on the feet. Both these birds had lost their tails, either naturally or by artificial means. As they belonged to the same exhibitor, we fear the latter. The fourth we did not like, being small, and mealy on the saddle. Fifth very large, but not well set up, and Buff several shades darker than the breast. Mr. Barnell's, No. 313, was a fine bird, and we thought worth more than he got. The rest were inferior for a Birmingham class.

10. The cup cockerel was magnificent, and only wanted a little more leg feather to make him perfect. He showed that fine even deep gold colour which is now getting rare. The second prize was almost a cinnamon, splendidly feathered, and fine shape. He would have been better had his wings been carried better; but as he was, no other bird could have been given his place. Third, a fine Cinnamon, honestly shown, and also deserving of his position. Fourth, rather light for breeding, but very even in colour, as was also the fifth prize. The sixth had a mealy wing, but good in other points. Pen 365 was a remarkably good cockerel, but rather light in colour. The four pens last mentioned had an uncommonly short allowance of tail.

11. The cup Buff hens were fair, but one was far inferior to the others, and we thought them far inferior to Mr. Cattell's third-prize pen, which were a long way the best in the class. One hen in the second-prize pen had a badly slipped wing. The fourth and fifth were good average pens, and we rather thought the highly commended pen, 404, ought to have displaced the latter pair. We did not think this class nearly so well judged as the preceding.

12. The cup pullets were badly matched—the larker a grand bird, but the other mealy in colour, and weedy in shape. We thought the second prize better. Third prize a decided error, the birds having no fluff or cushion, and very little of the Cochin about them. Mr. Alfred Stretch's pen, 416, should, we think, have had this position. The fourth, fifth, and sixth promised well, but needed a deal of filling out yet, and we greatly missed the fine-shaped birds Mr. Mapplebeck used to show in this class.

13. Except the prize birds, Partridge cocks were a poor class. First prize a very fine bird, but we liked the third prize better than Mr. Tudman's second, the latter showing the least possible suspicion of being round in the back.

14. In the cockerel class we did not much like any but the first prize bird.

15. The first prize hens were fine, but not so good as Mr. Tudman has shown before. The second prize contained one beautiful hen, but we preferred the same exhibitor's highly commended pen, 529.

16. The first prize pullets were a very nicely-marked pair, with specially neat heads. It would be rather a hard choice between them and second, which were very like them. The third prize were small, and did not look their age. Fourth very middling, and hardly any of the birds equal to the winners of last year.

17. Of the White cocks we liked the second prize best, the first being very yellow; the third very large, but almost bare-legged.

18. The first prize cockerel well shaped and clear, but small. The rest nowhere. In both these classes the birds seem to us to be losing fluff and shape.

19. The first and second prize hens were good pens, and nicely shown. Third prize very large, but exceedingly dirty. The highly commended pen, 595, almost deserved an extra prize.

20. Of the pullets, the second prize was certainly better than the first; both pens being very neat, but all the White Cochins decidedly need more attention to be given to shape.

BRAHMAS.

21. The old Dark Brahma cocks were exceedingly well judged, the first prize, especially, being magnificent. The second prize was the same as won second at Bristol in January while the cup-winner at Bristol and Birmingham was unnoticed on the present occasion, having moulted very light.

22. The cockerels were very inferior to last year's lot taken as a whole. The cup was taken by a very fine bird, but much too dark. Second and third good shape and colour, but small. Fourth a beautiful bird, and we think he ought to have had the cup. The fifth was inferior to several highly commended birds, and the sixth prize was much too narrow for a Brahma.

23. We think that the hens also were mistakingly judged, Mr. Lacey's third prize hens being the best in the class. The second prize was correctly placed, but Miss Pennant's highly commended pen (731) ought to have been third, in spite of rather a brown tinge.

24. The greatest mistake of all, however, we consider, was in the cup for dark pullets, which was given to a pen absolutely worthless, either for shape, size, or marking, and badly streaked with white. They were infinitely inferior to Lady Gwydyr's pen 763. The second and third pens were fine large dark birds. The second prize should have been first. The sixth prize were remarkable for fluff, but in other respects only middling. The best pair by far were dreadfully out of condition, and deservedly obtained only a highly commended, notwithstanding which they were bought by a well-known breeder at a good price. There were several other very good pens up and down, but the total value of the class would not be half that of last year.

25. The Light cocks showed progress, the first prize only needing rather more feather, while the second would have run him hard but the huckle been better striped. The third had a Cochin style of tail we did not like.

26. The first prize for cockerels went to a "pretty" bird of fine shape, but with wattles much longer than earlobes, which we did not like, and tail too much sickled. The second prize belonged to the same exhibitor, and was very similar, but better in tail. The third was a splendid bird for size, and in wonderful condition, considering he had crossed the Atlantic, but short of feather. Fourth, a nice clear bird, but rather too heavy hooks for the amount of feather his legs carried. We thought Mr. Pares' highly commended pen, 829, ought to have displaced one of the first two prizes, while a highly commended pen, 819, was the best-shaped of the lot, but small and dark in surface colour. This last bird will show far better as a cock next year.

27. The first prize Light hens were fine birds, very fairly feathered, and with good fluff. The second wanted cushion. The third prize were grand birds, and but for their Atlantic voyage must have been second. The best single hen was in pen 847, but her companion was nowhere.

28. The first prize pullets were very fine and rightly placed, though one would be better with more cushion. The second heavily feathered, but dirty, and with a strong suspicion of being hooked. Third prize uncommonly weak, but small. Fourth prize very fair, with dark but cloudy hackles. There was an American pair of pullets also, very large, but poorly feathered, and out of condition. There were several pens deservedly highly commended, and on the whole all the Light Brahma classes showed marked improvement in contrast to the deterioration of their dark relatives.

MALAYS.

29—32. There were twenty-seven entries of Malaya, and the classes contained several birds much better than usual. Being small classes they were, as a whole, well judged, but the first prize cockerel was quite destitute of the characteristic prominent Malay shoulders, and we thought the pullet, No. 903, better than that in the second prize pen.

CREVE-COEURS.

33. The Crève-Cœur cocks were of pretty fair quality, and the first prize a grand bird; second also a fine bird, but very much out of condition. Mr. Blinkhorn's pen, 919, was very fine, and also pen 907. The latter we thought might have had second prize.

34. We did not like the first prize hens, and thought the third prize pair the best in the class in all but the crest, in which the second prize surpassed them.

HOUDANS.

35. The Houdan cocks were a good class and well judged. Pen 956 must have been in the prize list but for his feet, which were very bad. Several birds, indeed, showed signs of bumble foot.

36. Both first and second prize hens were beautiful birds; third prize rather small but nicely shaped, and very dark. In both classes the colour was much improved, coloured feathers being rare.

LA FLECHE.

37. Of La Flèche cocks there were only four entries, and one of these was not sent. The third bird was shockingly out of condition, which made winning very easy.

38. The hens were in better order, but the second prize was a manifest error, being half-bred with Minorcas. This was evident all over, the birds having Spanish bodies, red faces, and one an actually flapping comb.

SPANISH.

39. The first and second prize cocks very good, but very full over the eye. Third free from this fault, and would probably have been second, but he was out of condition.

40. First prize cockerel a very good bird with nice comb, but not nearly so good as the third, which ought to have been first. Second prize very rough, and will soon be nearly blind. Fourth and fifth pretty good. Sixth prize a regular pullet's face, very cleanly shaved.

41. None of the hens in really good condition, but the second deserves mention as being shown and winning in the natural condition.

42. Much interest was exhibited in the Spanish pullet class from eight breeders having entered into a sweepstakes of £5 each, in addition to the prize list, which was divided into three prizes of £20, £12, and £8 respectively. The first prize were a splendid pair, but the second were, we think, not nearly so good as the third; and Mr. Barry's pen, 1079, third, putting the second prize as fourth. All the Spanish classes were as a whole inferior, though with some beautiful birds.

HAMBURGHIS.

43. BLACK.—The first Black Hamburg cock was magnificent, the second very good, but the third had a flabby comb which spoilt him.

44. The prize hens all good pens, but one in the third prize pen had a very bad comb, and we liked pen 1113 better.

45. GOLD-PENCILLED.—The second Gold-pencilled cock was better in tail than the first, but worse in comb; the third better than either but for many foul feathers in the under parts.

46. Hens were very middling. Third prize in bad health, and on Monday had decided roup. This class seemed losing colour.

47. SILVER-PENCILLED.—The first prize cock had a large comb, but his tail was beautifully edged. The second prize bird was a beauty. The third and fourth were fairly good.

48. In hens the first and second were well marked, but the third rather poor.

49. GOLD-SPANGLED.—The first prize cock was a magnificent bird; the rest very good, and on the whole well placed. This was a good class.

50. Hens also good, and first two prizes very accurately marked on the cushion.

51. SILVER-SPANGLED.—The first prize bird had a bad breast, but by far the most perfect tail we ever remember seeing. The second had a beautiful breast, but otherwise much inferior. Rest fair average prize birds.

52. In the hens many were too dark, and of those which were not, several had moulted considerably. All the prize pens were good, but we thought the third as good as any.

POLANDS.

53—58. The Polish classes were very much better than usual. The prize Golden pens were particularly fine in marking, and made it very easy to see where the Sebright Bantams came from.

ANY OTHER VARIETY.

59. In ANY OTHER VARIETY the third prize was a great error, the Creeper hen having feathered legs and also a Cochinchina head—in fact, a cross-bred bird. Much interest was awakened by Mr. Simpson's pen of Dominiques, which happened to be next to a pen of Cuckoo Dorkings. The marking and general appearance are precisely similar, but they had yellow legs, single toes, and rose combs. But for there being two hens this pen ought to have been third.

GAME.

60. The Black Red cocks did not seem a remarkable class, and many birds showed defect in the hock toe. The first prize was a beautiful bird in good condition, but we thought Mr. Challoner's, 1355, ought not to have been far off. Second prize rather darker in colour, and both second and third seemed a little long in the thigh, but we heard little fault found with the judgment. Many of the prize and other birds in the Game classes showed this tendency, which seems to us increasing.

61. The cup cockerel was really a beauty, and no one could quarrel with his position. The second prize of the same owner was nearly as good. Third prize a very tight, compact bird. The fourth prize looked to us rather more of a "cocker's" bird than some of the others. Fifth prize too long in thigh for our fancy, but hard in feather and body. Sixth prize a particularly good head, sharp and thin. The highly commended bird, 1401, had thighs at least 4 inches long. Several cockerels in this class looked to us too large for Game fowls, and at least one showed a very strong cross with the Malay. The judgment in these two classes we thought very fair on the whole, but to go, perhaps, a little too much by the tail's.

62. The first Black Red hen was a fine gamey bird, but we thought her a little too plump. Second prize very neat and trim, and third ditto, but apparently with rather less than her share of hackle. The rest of the class hardly up to the mark.

63. The pullets were far better. First prize a beauty, just the size, and head, neck, legs, and body, alike good. The second prize a good medium-sized bird, with fine spreading toes. Third prize very good in all but one point, a very sharp angle between the head and the beak, which a Game bird ought not to have. The fourth we did not like much, and the fifth, which was a beautiful gamey bird, ought to have taken her place, if not put third, which might have been better still. Sixth, rather too much flesh to our liking, but for which we think she would have cut the work out for at least two or three of the others to heat her.

64. The first prize Brown Red cock was rather large, but both this and the second prize were fine thorough Game fowls, and however they settled it, ought to have had the first two prizes. Third prize nearly, if not quite as good as the first. Fourth, a little too big, and we are not sure we should not have changed fourth with fifth, which we liked much. Pen 1527, was also a fine bird, but this class was admitted to be well judged.

65. The cup Brown Red cockerel seemed to us only a fair bird, but was shown in capital feather. The second and third must have been hard to choose with him. Fourth prize rather too dark in colour for a Brown Red. Fifth and sixth deserved their places. Not a very good general class.

66. Mr. Brierley's Crown Red first prize hen was perfection, but we thought the second prize weedy and had. Third a very nice bird, particularly good in the neck. Fourth prize also a very good hen.

67. In the pullet class, Mr. Brierley repeated his success with a super-excellent bird, hardly a fault about her. Second prize good, but a little red in the face. The rest of the first prize birds we thought well placed, in a really fine class.

68 and 69. The Duckwing cocks were a rather small class. We think pen 1620 should have displaced at least the third prize, but otherwise they were admitted to be well judged, as were the cockerels, except the fifth prize bird, who carried his wings very high, almost over his back. There were several birds, especially pen 1646, which might have had his place with advantage.

70. Two prize Duckwing hens were good, but except one of Mr. Fritill's, the rest were poor, and the entries were only seven in number.

71. The pullets were better, and the first was a beauty. We thought the third about as good, but did not like the second much, and cannot call it a remarkably good class for Birmingham.

72. The Black Game cocks and cockerels appeared rather heavy, which has been a fault of late years. The first prize was a long way ahead, but had to be removed elsewhere for the welfare of his next-door neighbour.

73. In hens or pullets, the first-prize bird was a beauty in every way. Second was of good shape, but as red in the face as a Minorca.

74. In the White and Pile cocks, the first two birds were unusually good, and rightly placed, but we thought either 1705 or 1710 better than the third prize.

75. The first-prize bird in the female department struck us as one of the very best-shaped birds in all the Game classes. Second and third good fair birds, but the rest of class we thought poor.

BANTAMS.

76—82. The Sebrights were numerous and good, the Silvers particularly fine. They are again getting white. The White Bantams were mostly too large, but it was a large and good class, the first prize being gems. Black also very good, the fourth prize rather wanting in style. In the "Any variety," the first prize went to a good pair of Pekins, the second to a pen of Japanese, with the most perfectly marked tail ever, perhaps, seen. Black Red Game Bantams were a grand class. In the first prize pen, the cock and one hen were perfection, the other not so good. We were sorry to see that some disappointed miscreant had pulled out one of the cock's sickle feathers. Many of the birds in this class carried their wings low. In the Brown Reds, the second-prize pen contained a poor cock, but the hens were much the best in the class. These two classes were, however, very hard to judge, there being so many good pens.

83. In the "Any variety" Game Bantam class, the first and second were both good pens, but the third prize pen of Piles was a great error, there being another pen of Piles worth fifty of them. In fact, this pen (1855) of Mr. Easton's was said by many to be the best in the class; and though the hens did not quite match, the birds were so unusually "gamey," as well to deserve that position.

84. In the Black-breasted cock class, the first prize was a fair bird, but too much hackle; second a middling bird, but in magnificent condition. Third, fourth, and fifth a good average, but we thought several pens rather better. In the "Any other variety" (85), the first was a Pile of very good quality; the third also a Pile, but not so good; the second a Duckwing rather too dark in colour.

DUCKS, GESE, AND TURKEYS.

Aylesbury Ducks were large and fine, the weight of the four prizes respectively being 18 lbs. 9 ozs., 18 lbs. 10 ozs., 17 lbs. 10 ozs., and 18 lbs. 4 ozs. Rouens were again heavier, weighing 19 lbs. 4 ozs., 18 lbs. 6 ozs., 18 lbs. 2 ozs., 17 lbs. 11 ozs., 17 lbs. 4 ozs., and 17 lbs. 5 ozs. respectively. The first prize pen of the latter breed was magnificent, and it is worth remark that twenty pens were noticed by the Judges. The Blacks were a very nice class and in good condition. In the "Any variety" Duck class the Mandarins and Carolinas showed in great force, and the prize birds were more perfect

in marking than ever. The ladies lingered round this class. 2015 was a beautiful pen.

The White Geese weighed 58 lbs. 12 ozs., and 56 lbs. 5 ozs.; the young ones 19 lbs. 1 oz., and 19 lbs. Grey, 62 lbs. 6 ozs., and 51 lbs. 6 oz.; young ones, 33 lbs. 6 ozs., and 49 lbs. 1 oz. The first prize old Greys were really enormous, as the weight will show.

The first prize for all Turkey cocks was won by a splendid bird sent over by Mr. Simpson. Notwithstanding the voyage he was in the best order of any in the class, and weighed 36 lbs. 4 ozs., being said to have gained several pounds on the passage. The same gentleman was very highly commended for a crested bird. The second prize weighed 35 lbs. 2 ozs. The young cocks were 21 lbs. 6 ozs., and 23 lbs. 12 ozs. respectively, and seventeen pens were distinguished by the Judges. Old hens weighed 35 lbs. and 31 lbs.; young ones 31 lbs. 4 ozs., and 29 lbs. 1 oz. These weights have been somewhat exceeded, but are very good.

Looking over the whole Show, in spite of many individual exceptions, we were struck with its great inferiority in quality to the usual Birmingham average, which may probably be accounted for by the Crystal Palace Show next week. Greater dissatisfaction than usual of late was also expressed with the awards. This may partly be accounted for by the great waste of judging power caused by dividing the Judges into parties of three each; but much more, it seems to us, by the extremely bad light this year, which told severely on the lower tier of birds. If by any other order of the classes the lower rank could be filled by those breeds which bear a bad light best, we are convinced many otherwise unaccountable errors would be avoided.

In point of attendance, and also of sales, the 1870 meeting was very successful.

[We hope to give notes on the Pigeons next week.]

DORINGS (Coloured, except Silver-Gray).—Cocks.—1, Mrs. Arkwright, Sutton Scariside, Chesterfield. 2, Gunson & Jefferson, Whitehaven. 3, J. Faulmer, Burton-on-Trent. 4, Admiral W. Horn's, Poole. 5, Admiral W. Purney, H. Yardley, Birmingham. Rev. E. Colclough, Wal on Parsonage, Warwick.

DORINGS (Coloured, except Silver-Gray).—Cocks. 1, and Cup, Glessall and Waller, Milnthorpe. 2, and 4, Mrs. F. Wheatley, Belper. 3, Proves, Ingatestone. 5, R. B. Wood, Woodburners. 6, J. White, Warrington, Norththorp. 7, Henry Woodcock, Warkington, Goodham Marlow. 8, Rev. J. A. Baker, Old Warden, Biggleswade. 9, Andrews, Tuxford, Newark. 10, Parlett, Great Baddow, Chelmsford. 11, Gunson & J. Beeson, Whit haven. 12, Countess of Dartmouth, Pat-bull, Alburgh. 13, Wolchampton, Gunson & Jefferson (2); Mrs. Scamons, Hartwell, Aylesbury. 14, White, Warley, Northampton. 15, W. Rutledge, Shortland, Kendal. 16, E. Shaw, Plas Wilnot, Oswestry. R. Wood, Clapton, Thrapston.

DORINGS (Coloured, except Silver-Gray).—Hens.—1, J. White. 2, Rev. E. Colclough. 3, and 5, L. Patton, Hillmore, Tamworth. 4, Gunson & Jefferson. 6, T. Statter, Watfield. 7, Mrs. Arkwright. 8, Watta, King's Heath, Birmingham. Earl of Chesterfield, Prestly Hall, Burton-on-Trent.

DORINGS (Coloured, except Silver-Gray).—Pullets.—1 and Cup, L. Patton. 2, Mrs. E. Wheatley. 3, R. W. Beachy, Blunder House, King's-croft. 4, J. Fox, St. Eves. 5, Mrs. Arkwright. 6, L. Patton. 7, Mrs. Hart, Alderley-joy. 8, H. Wingwood. 9, Gunson & Jefferson (3). 10, J. White; Mrs. Bird; Mrs. Scamons, Hartwell. 11, Silver. 12, Hon. Lady Bazel, Blithfield Hall, Epsley.

DORINGS (Silver-Gray).—Cocks.—1, Hon. Lady Bazel, Blithfield Hall, Epsley. 2, Gunson & Jefferson. 3, O. E. Cresswell, Bagworth Rectory, Rotham. 4, T. Statter. 5, R. Smalley, Lam Milla, Loughborough. 6, Gunson & Jefferson.

DORINGS (Silver-Gray).—Hens or Pullets.—1, R. D. Orr, Otter Head, Windermere. 2, J. Horton, Shirley. 3, W. W. Rutledge, Shortland, Kendal. 4, R. Smalley. 5, W. A. Beach, Shirley. 6, J. Watta, St. W. W. Wood, J. Gordon.

DORINGS (White).—Hens or Pullets.—1, Mrs. E. Farnham, Walsby. 2, J. Choyce, Pinball Garage, Atherton. 3, and 4, Rev. T. Peake, Gazeley Vicarage, Newark.

DORING (White).—Hens or Pullets.—1, S. Robinson, Gunstang. 2, Hon. Lord Sudley, Tuddington, Wiltshire. 3, J. Choyce. 4, Rev. T. Peake; O. E. Cresswell. 5, Miss Fairhurst, Choyce.

COCHIN-CHINA (Cinnamon and Buff).—Cocks.—1, Cup, and Extra, Mrs. R. White. 2, and 3, W. A. Taylor, Manselwood. 4, C. Felton, Birmingham. 5, H. Bondman, Mosley. 6, H. Farley, H. Bondman.

COCHIN-CHINA (Cinnamon and Buff).—Cocks.—1, Cup, and Extra, and 5 and 6, W. A. Taylor. 2, G. H. Proctor, Durham. 3, Mrs. R. White. 4, Hon. Lady Gwydyr, Ipswich. 5, Mrs. Wilkin, Boodle, Carnforth. 6, Cheeky and Dove, Mouldon, Northampton. 7, Mrs. Allsopp, Bindly Hall, Worcester. 8, W. Sankey, R. Kelleton, Trent, Nottingham. 9, Lady Gwydyr, C. Felton.

COCHIN-CHINA (Cinnamon and Buff).—Hens.—1, Cup, and Extra, W. A. Taylor. 2, and 3, C. Felton. 4, and 5, J. C. Atwell, Bristol Road, Birmingham. 6, W. Sankey.

COCHIN-CHINA (Cinnamon and Buff).—Pullets.—1, Cup, and Extra, Hon. Lady Gwydyr. 2, and 5, Henry L. Wood. 3, R. Hall, Great Barford, Deddington. 4, W. Sankey. 5, W. A. Taylor. 6, C. Felton. 7, Cheeky & Dove.

COCHIN-CHINA (Brown and Partridge-colored).—Cocks.—1, and 2, E. Tudman, Whitechurch, Salop. 3, Horace Lingwood, Crocing, Needham Market.

COCHIN-CHINA (Brown and Partridge-colored).—Cocks.—1, H. Crossley, Bramhall, 2, R. B. Wood, 3, C. Sidwick, Kingley. 4, F. E. Hayward, Southam. 5, W. A. Taylor.

COCHIN-CHINA (Brown and Partridge-colored).—Hens.—1, E. Tudman. 2, and 3, W. A. Taylor. 4, H. Crossley, Walsall.

COCHIN-CHINA (Brown and Partridge-colored).—Pullets.—1, W. A. Taylor. 2, and 3, H. Crossley, Broadfield, Halifax. 4, Mrs. R. White. 5, J. Goulden, jun., Altrincham. 6, W. Stretch, Olmick.

COCHIN-CHINA (White).—Cocks.—1, F. E. Farnham, Whitehaven. 2, G. Shrimpton, London Road. 3, Miss Hales, Canterbury.

COCHIN-CHINA (White).—Cocks.—1, R. Chase, White Green, Birmingham. 2, E. Fearon, Whitehaven. 3, A. D. Cochrane, Stourbridge. 4, R. Smalley. 5, A. J. E. Swindell, Heathland, Kinver, Stourbridge. 6, Dowsett, Pleshey, Chelmsford.

COCHIN-CHINA (White).—Hens.—1, R. Smalley. 2, J. Sichel, Timperley, Cheshire. 3, F. & C. Haworth, Newfield, Hampshire. 4, E. Fearon.

COCHIN-CHINA (White).—Pullets.—1 and Cup, Hon. Mrs. A. B. Hamilton. 2 and 4, Mrs. Hart. 3, Lady Gwydyr. 5 and 6, H. B. Morrell, Gae Mawr, Clyro. 7, Mrs. Hart. 8, Wright, Kingsdown, Bristol. Rev. F. Alder, Etwall Vicarage, Derby. 9, W. Sims, Strout; Hon. Lady Gwydyr; H. B. Morrell; Rev. J. Bowen, Henry's Moor Rectory, Havortfordwest. 10, Rev. J. J. Evans; H. Lacy; Mrs. Hart; G. F. Whitehouse; Rev. F. Alder.

COCHIN-CHINA (White).—Cocks.—1, J. J. Pares, Guildford. 2, F. Crook, Forest B. H. London. 3, H. M. Maynard, Holmwood, Ryde, Isle of Wight. 4, Mrs. Williamson. 5, Dowsett; J. Pares. 6, Miss Hales; Mrs. Williamson.

COCHIN-CHINA (White).—Cocks.—1 and 2, W. T. Storer, Shutt Green, Crewdson, Stafford. 3, W. Simpson, jun., New York. 4, H. M. Maynard. 5, F. Crook; J. Pares. 6, Rev. N. J. Ridley, Newbury.

COCHIN-CHINA (Light).—Hens.—1, J. R. Rodbard, Altwick Court, Wrington, Bristol. 2, J. Pares. 3, W. Simpson, jun., West Farms, New York. 4, H. Dowsett. 5, F. Crook.

COCHIN-CHINA (Light).—Pullets.—1 and Cup, F. Crook. 2, C. Morris, Holmleigh, Grassendale, Liverpool. 3, M. Leno, Markyate Street, Danstable. 4, J. Pares. 5, Mrs. Williamson; Miss Hales, Canterbury. 6, Morris; J. F. White, Birmingham; W. T. Storer; H. Dowsett. 7, J. R. Rodbard; M. Leno; A. D. Worthington, Burton-on-Trent.

COCHIN-CHINA (Light).—Cocks.—1, T. Hollis, Twyford, Berks. 2, A. D. Payne, Lyth Hill, Shrewsbury.

COCHIN-CHINA (Light).—Cocks.—1, J. S. South, Chesterfield. 2, Rev. A. G. Brooke, The Rectory, Shrawburne, Salop. 3, Hon. J. Massy, Limerick.

COCHIN-CHINA (Light).—Hens.—1, Rev. A. G. Brooke. 2, T. Hollis. 3, J. J. Wilton, Ryhope, Sunderland.

COCHIN-CHINA (Light).—Pullets.—1, Rev. A. G. Brooke. 2, J. S. South. 3, Rev. A. G. Brooke; A. D. Payne.

COCHIN-CHINA (Light).—Cocks.—1, W. R. Park, Abbot-meadway, Melrose, N.B. 2, H. Beldon, Goldcock, Pimlico. 3, Hon. H. M. Fitzwilliam, Wentworth Woodhouse, Rotherham. 4, Hon. J. Massy; C. Morris; J. Watta. 5, A. D. A. care of Mr. Swan, Birches Green, Birmingham.

COCHIN-CHINA (Light).—Hens or Pullets.—1, J. K. Fowler, Aylesbury. 2, W. R. Park. 3, W. Blunkhorn, Waterdale, St. Helens. 4, Mrs. Wilkin, Boodle, Carnforth, Cumbreland; R. B. Wood; C. H. Smith, Ratchiffon-Tren.

COCHIN-CHINA (Light).—Cocks.—1 and 3, R. B. Wood. 2, P. Lane, Hanwick, Gloucester. 4, R. B. Wood. 5, E. W. Stratford, Nailstone, Kent; Mrs. Wilkin.

COCHIN-CHINA (Light).—Hens or Pullets.—1, W. G. Quibel. 2, R. B. Wood. 3, D. Lane. 4, W. Tippler, Boxwell, Chelmsford, Essex. 5, Morris; Rev. C. B. Rowland, Lighthorne, Watwick; W. Dring, Eversham, Kent; J. Dreyry, Drakelow, Burton-on-Trent; F. W. Stratford.

COCHIN-CHINA (Light).—Cocks.—1, G. A. Stephens, Dublin. 2, Rev. N. J. Ridley, Newbury.

COCHIN-CHINA (Light).—Hens or Pullets.—1 and 2, Hon. C. W. Fitzwilliam.

COCHIN-CHINA (Light).—Cocks.—1 and 2, Hon. C. W. Fitzwilliam. 3, R. Teebay, Fulwood. 4, Hon. Miss D. Pennant; Mrs. Allsopp.

COCHIN-CHINA (Light).—Cocks.—1 and Cup, G. W. Brierley, M. Jellison, Manchester. 2, T. Bamfield, Brandon Hill, Giffon. 3, E. Jones, Clifton, Bristol. 4, Mrs. Allsopp. 5, E. Jackson, Finch St. Wolverhampton. 6, J. Walker, Wolverhampton. 7, Hon. Miss D. Pennant; J. Walker; E. Jones; E. Jackson; W. R. Bull, Newport Pagnell, Bucks.

COCHIN-CHINA (Light).—Hens.—1, Hon. Miss D. Pennant. 2, J. Watta. 3, H. Beldon. 4, Mrs. Allsopp. 5, E. Jones. 6, T. Bamfield. 7, Mrs. Hyde, Bedminster, Bristol. 8, H. Lane, Ashley Road, Bristol. 9, H. T. C. & E. Newth, Epworth; J. Barry, Tetterdown, Bristol. 10, W. R. Bull. 11, T. Bamfield.

COCHIN-CHINA (Light).—Cocks.—1, Rev. W. Serjeantson, Acton Burnell Rectory, Shrewsbury. 2, D. Lord, St. Luke's, Manchester. 3, E. Brierley, Heywood, Manchester. 4, Duke of Sutherland, Stoke-on-Trent; Rev. W. Serjeantson; C. Sidwick; J. Smith, Gilshead, Bingley; J. Knott & Co., Slatwhate. 5, A. Woods, St. John, Liverpool; Rev. W. Serjeantson.

COCHIN-CHINA (Light).—Hens or Pullets.—1, Rev. W. Serjeantson. 2, J. M. Khyrt, Wm. Sabo. 3, S. Shaw, Standish, Halifax. 4, Rev. W. Serjeantson; C. Sidwick; A. Woods. 5, E. Briarty; W. Birch, Barnacre, Coventry; Mason and Walker, Denton, Manchester.

COCHIN-CHINA (Light).—Cocks.—1, J. Preston, Allerton, Bradford. 2, H. B. Don. 3, Duke of Sutherland; 4, Duke of Sutherland; J. W. Will, Eyed, Scotland.

COCHIN-CHINA (Light).—Hens or Pullets.—1 and 2, F. Perrin, Ashley Vale, Bristol. 3, H. Beldon. 4, W. R. Park.

COCHIN-CHINA (Light).—Cocks.—1, H. B. Don. 2, H. Pickles, jun. 3, F. & C. Haworth, Newfield. 4, Duke of Sutherland. 5, Duke of Sutherland; F. & C. Haworth. 6, H. Bee, Gosmanthorp, Preston.

COCHIN-CHINA (Light).—Hens or Pullets.—1, Duke of Sutherland. 2, F. & C. Haworth. 3, H. B. Don. 4, W. Bainslow, Farncliffe, Bingley.

COCHIN-CHINA (Light).—Cocks.—1, H. Beldon. 2, and 4, J. Buckley, Tanton, Ashburnham, Wiltshire. 3, Mrs. Brierley, Denton, Manchester. 5 and 6, W. A. Taylor, Great Ashton and R. Lyne. 7, J. Ogden, Hollinwood, Manchester. 8, Brierley. 9, Miss C. E. Palmer, Lighthorne, Warwick. 10, A. Woods.

COCHIN-CHINA (Light).—Hens or Pullets.—1, J. Chalderton, Hollinwood, Manchester. 2, J. Ogden. 3, A. Woods. 4, Mason & Walker. 5, W. A. Hyde. 6, N. Marlor; E. Brierley; J. Buckley; J. Ogden. 7, J. Buckley.

COCHIN-CHINA (Light).—Cocks.—1, H. Pickles, inn. 2 and 4, J. Fielding. 3, W. McMellon, Glossop. 5, Ashton & Booth, Broadbottom, Mottram, Cheshire. 6, H. Beldon. 7, W. Bainslow.

COCHIN-CHINA (Light).—Hens or Pullets.—1, Ashton & Booth. 2, J. Fielding. 3, H. Beldon. 4, W. McMellon. 5, Miss E. Brown, Chardleigh Green, Chard. 6, J. W. Will, Errol, Perthshire; Ashton & Booth. 7, C. J. Fielding.

COCHIN-CHINA (Light).—Cocks.—1, W. Gamon, Chester. 2, S. Shaw, Standish, Halifax. 3, T. Dean, Kingley; T. P. Edwards, Lyndhurst.

COCHIN-CHINA (Light).—Hens or Pullets.—1 and 2, S. Shaw. 3, T. P. Edwards.

COCHIN-CHINA (Light).—Cocks.—1, M. Nicholls, Peel, Isle of Man. 2, W. R. Patrick, West Wyalong, Wiltshire. 3, G. W. Boothby, Louisa; M. Nicholls; P. Unsworth, Lewton, Newton-le-Willows.

COCHIN-CHINA (Light).—Hens or Pullets.—1, H. Beldon. 2, W. R. Patrick. 3, W. R. Patrick. 4, S. Shaw; G. W. Boothby; J. Watta.

COCHIN-CHINA (Light).—Cocks.—1, W. Gamon. 2, H. Beldon. 3, F. Pickles. 4, W. Gamon; P. Unsworth; G. C. Adams, The Lightwoods, Birmingham.

COCHIN-CHINA (Light).—Hens or Pullets.—1, G. C. Adams. 2, H. Pickles, jun. 3, G. C. Adams (2); J. Scotson, Little Byrom, Lewton, Newton-le-Willows; H. Beldon.

ANY OTHER VARIETY.—1, Hon. C. W. Finch, Coventry. 2, Mrs. Wilkin. 3, Miss C. H. Palmer. 4, G. Barnell, Kingley; C. F. Montresor, Hiersnell, Slough. 5, H. Saville, Ollerton.

GAME (Black-breasted Reds).—Cocks.—1 and Cup, J. H. Macnab, South Arthur, Barrow. 2, J. Douglas, Clumber Aviares, Worksop. 3, C. E. Smith, Scarborough. 4, S. M. G. H. W. Crowe, Doncaster. 5 and 6, J. Fryth, Wetherhampton. 7, E. C. Gilbert, Penkridge (3).

GAME (Black-breasted Reds).—1, 2, and Cup, J. Mason, St. John's, Worcester. 3, S. Beighton, Farnsfield, Nottingham. 4, G. Bagnall, Draycott, Cheshire. 5, W. H. Stag, Netheravon, Povey. 6, E. Aykroyd, Eccleshill, Leeds. 7, W. Spencer, Haworth; E. Mann, Wallfield, Stand, Pilkington; Capt. G. Price, Taynton, Gloucester; S. Deacon, jun., Oudick. 8, C. J. Halsall, Eccleston, St. Helens; S. Matthews.

GAME (Black-headed Reds).—Hens.—1, C. Chaloner, Steely, Whitwell, Chesham. 2, W. D. Pope, Biggleswade. 3, T. Mason, Green Ayr, Luncheon.

GAME (Black-headed Reds).—Pullets.—1, 3, and Cup, W. J. Pope. 2, C. Chaloner. 4, G. Cottle, West Felton, Salop. 5, J. Sunderland, Hippelshelm, Halifax. 6, C. W. Brierley. 7, C. Chaloner; J. Frith; G. E. Peach, Wellington, Salop. 8, W. Spencer, Haworth; W. Johnson, Stanley, Liverpool. 9, G. C. Clements, Birmingham. 10, S. Beighton, Farnsfield; J. Laming, Spalding; G. Cottle; J. Sunderland.

GAME (Brown and other Reds, except Black-breasted).—Cocks—1, 3, and 4, J. Wood, Wigan. 2, C. W. Brierley. 5, T. Burgess, Burleydam, Whitechurch, Salop.

GAME (Brown and other Reds, except Black-breasted).—Cockrels—1, E. Mann. 2, J. Wood. 3, C. Chaloner. 4, R. Swift, Southwell, Notts. 5, W. Boulton, Dalton-in-Furness. 6, W. Dunning, Newport, Salop. *hc*, T. Burgess.

GAME (Brown and other Reds, except Black-breasted).—Hens—1, C. W. Brierley. 2, T. Burgess. 3, J. Wood. 4, J. Frith. *hc*, J. Wood; J. H. Wilson, St. Bees.

GAME (Brown and other Reds, except Black-breasted).—Pullets—1, C. W. Brierley. 2, S. Matthew. 3 and 4, J. Wood. 5, W. Boulton, Dalton-in-Furness. *hc*, T. Burgess; W. Boulton, c. J. Wood.

GAME (Duckings, and other Greys and Blues).—Cocks—1, S. Matthew. 2, C. Chaloner. 3, J. H. Wilson. 4, J. H. Bradwell, Southwell, Notts. *hc*, J. Mason. 5, W. Bradley, Severn Navigation, Worcester.

GAME (Duckings, and other Greys and Blues).—Cockrels—1, J. Frith. 2 and 4, S. Matthew. 3, G. Dingley, Shustoke, Colehill. 5, W. Dunning, Newport, Salop. *hc*, W. C. Phillips, Worcester; C. Chaloner. 6, W. H. L. Clare, Twycross, Atherstone.

GAME (Duckings, and other Greys and Blues).—Hens—1, J. W. Thompson, St. Ann's, Southwram, Halifax. 2, J. Mason. *hc*, C. Chaloner.

GAME (Duckings, and other Greys and Blues).—Pullets—1, W. Johnson, Stanley, Liverpool. 2, W. Bradley. 3, J. Frith.

GAME (Blacks and Brass-winged, except Greys).—Cocks—1 and 3, Capt. W. G. Webb, Totton. 2, R. Robbins, Kenilworth.

GAME (Blacks and Brass-winged, except Greys).—Hens or Pullets—1, Rev. G. S. Crawley. 2, R. Robbins. 3, Capt. W. G. Webb. 4, J. H. Dawes.

GAME (White and Piles).—Cocks—1, C. W. Brierley. 2 and 3, J. Sunderland, Hipperholme, Halifax. *hc*, J. H. Salter, Tullshunt Darcy, Kelvedon, Essex. 4, F. Sales, Crowle, Doncaster.

GAME (White and Piles).—Hens or Pullets—1, C. W. Brierley. 2, J. Frith. 3, W. H. L. Clare, Twycross, Atherstone. *hc*, J. W. Thompson, St. Ann's, Southwram, Halifax; W. Jones, Malpas, Newport.

BANTAMS (Gold-laced).—Cocks—1, 2, M. Leno. *hc*, Rev. G. S. Crawley; S. A. Wyllie, East Monksley, Surrey.

BANTAMS (Silver-laced).—M. Leno. 2, Rev. G. S. Crawley. *hc*, M. Leno; J. Watts. c. H. Draycott, Humberstone, Leicester.

BANTAMS (White, Clean-legged).—1, Rev. F. Tearle, Gazeley Vicarage, Newark, Notts. *hc*, Rev. F. Tearle; H. Beldon. c. Bell & Thorpe, Padlock North, Stratford-on-Avon.

BANTAMS (Black, Clean-legged).—1 and 3, E. Cambridge. 2, H. Beldon. 4, J. Walker, Pelton Lane, Halifax. *hc*, S. & R. Ashton; T. Dean, Keighley; J. Walker.

BANTAMS (Any other variety, except Game).—1, W. J. Cope, Bamsley, 2, Mrs. Woodcock, Leicester. *hc*, Countess of Aylesford, Coventry; W. W. Lord, Birmingham; H. Draycott (2).

GAME BANTAMS (Black-breasted Reds).—1 and Cup, H. Shumach, Southwell. 2, W. Hodgson, Darthong. 3, Williams & Straw, Farnsheld, Southwell. 4, G. Maples, jun., Waverley, Liverpool. 5, J. W. Morris, Rochdale. *hc*, R. Swift, Southwell; J. Crossland, jun., Wakefield; H. J. Edge, Bassford, Nottingham. c. Miss E. Crawford, Farnsheld, Southwell; J. Palmer, Longford, Coventry.

GAME BANTAMS (Brown and other Reds, except Black-breasted).—1, J. Palmer. 2 and c, H. Shumach, Southwell.

GAME BANTAMS (Any other variety).—1, Miss E. Crawford. 2, Williams and Straw. 3, G. Smith, Staveley, Chesterfield.

GAME BANTAMS (Black-breasted and other Reds).—Cocks—1, Williams and Straw. 2, W. Hinchliff, Farnsheld. 3, G. Smith. 4, E. Hudson, Ulverston. 5, H. Shumach, *hc*, H. P. Fowler, Bury St. Edmunds; J. Frith, Chatsworth, Bakewell; G. Maples, jun., Waverley, Liverpool; E. Hudson. c. F. H. Jones, Fulham, London; J. Rhodes, Accrington.

GAME BANTAMS (Any other variety).—Cocks—1, T. C. & E. Newbitt. 2, Miss E. Crawford. 3, G. Smith. c. J. Rhodes; H. Shumach; Mason & Charlesworth, Chesterfield.

DUCKS (White Aylesbury).—1, E. Leech, Rochdale. 2, H. Jones, Dinton, Aylesbury. 3, Mrs. Seamons. 4, Lady Gwydyr. *hc*, Mrs. Seamons (3); J. K. Fowler. *hc*, J. K. Fowler.

DUCKS (Rouen).—1 and Cup, and 2, T. Staller. 2, L. Patton. 4, A. Dickinson, Westcott, Whitehaven. 5, W. Gamon. 6, J. Scotland, Little Byrom, Lowton, Newton-le-Willows. *hc*, Ganson & Jefferson; T. Burns, Abham, Wigan; S. H. Stott, Quarry Hill, Rochdale; L. Patton (2); R. Gladstone, jun., Courthey, Broad Green, Liverpool; The Countess of Dartmouth, Patchell, Wolverhampton; A. Woods; J. K. Fowler. c. L. H. Ricketts, Banwell; A. Woods (2); Ganson & Jefferson (2).

DUCKS (Black Easton).—1 and Plate. Rev. W. Serjeantson. 2, W. E. George, Downside, Bristol. 3, S. Burn, Whitby. *hc*, Mrs. M. A. Hayne, Fortington, Dorchester (2); S. Barn.

DUCKS (Any other variety).—1, M. Leno. 2, C. Baker, Long Street, Atherstone. *hc*, H. Mapplebeck (2); J. Watts; C. Baker; J. K. Fowler; S. H. Stott; Rev. W. Serjeantson; T. C. Harrison, Beverley Road, Hull. c. M. Leno; E. L. Cleeve, Chad Hill, Edbaston.

GESE (White).—1, Rev. G. H. Huxter, Stillingfleet Vicarage, York. 2, E. Leech. *hc*, Mrs. Seamons. c. J. Lyett.

GESE (Grey).—1, Rev. G. H. Huxter, Stillingfleet Vicarage, York. 2, E. Leech. *hc*, Mrs. Seamons. 3, J. Lyett. *hc*, Mrs. Seamons; Rev. G. Huxter (2); J. K. Fowler; W. E. George. c. A. Roxburgh.

GESE (Grey and Mottled).—1, Mrs. Seamons. 2, J. K. Fowler. *hc*, Rev. G. Huxter; J. Lyett. c. W. Lort, King's Norton, Birmingham.

GESE (Grey and Mottled).—1, J. K. Fowler. 2, J. Lyett. *hc*, Hon. Ladies W. Fitzwilliam, Wellington; J. K. Fowler; W. Lort; Rev. G. Huxter; Mrs. Seamons; S. H. Stott.

TURKEYS—Adult Hens. 1 and *hc*, W. Simpson, jun., New York. 2, F. Lythall, Banbury. *hc*, Hon. Mrs. A. B. Hamilton; Mrs. Parsons, Bridgnorth; Miss M. Brown, Docester; Rev. H. G. Baily, Swindon; L. Patton; J. Burgess; J. Fox, St. Bees, Camberland; F. Lythall; W. Wykes, Wolvey, Hincley, c. Miss C. E. Palmer; J. N. Beasley, Northampton; Rev. N. J. Ridley, Newbury; N. J. Jenaway, Crayfield, Kenilworth; R. Hall.

TURKEYS—Young Cocks. 1 and 2, F. Lythall. *hc*, Miss J. Milward, Newton St. Loge, Bristol; W. Tipper, Roxwell, Chelmsford; J. Burgess; F. Lythall (2); E. Kendrick, jun., Westford, Litchfield. c. Hon. Mrs. Colville, Lullington, Burton-on-Trent; E. Kendrick, jun.; W. Wykes.

TURKEYS—Adult Hens. 1, F. S. Rawson, Thorpe, Halifax. 2, F. Lythall. *hc*, Rev. N. J. Ridley; J. Burgess.

TURKEYS—Young Hens. 1 and 2, E. Leech. *hc*, Mrs. Winterton, Hincley; F. Lythall; Rev. G. Gilbey, Claxton, Norwich; W. Wykes; E. Kendrick, jun.

MAIDS, Ladd, Calne. c. A. Heath, Calne. Hens—1 and 2, R. Fulton. *hc*, Mrs. Ladd; A. Heath.

POUTERS (Any other colour).—Cocks—1, R. Fulton. 2, A. H. Stewart. *Hens*—1 and 2, R. Fulton. c. A. H. Stewart.

BARDS OR BARDS—1 and 3, W. H. C. Oates, Resthorpe, Newark, Notts. 2, J. Fielding, jun. *hc*, R. Fulton.

TUMBLERS (Short-faced).—1, J. Ford. 2, R. Fulton. *hc*, R. Minnitt, jun., Huxley Vicarage, Rochdale; R. Fulton.

TUMBLERS (Long-nosed).—1 and 2, E. D. Careless, Birmingham.

TUMBLERS (Any other variety).—1, J. Hawley. 2, J. Watts.

RUFFS—1 and Cup, H. Yardley. 2, P. H. Jones. *hc*, Lady F. Eshby, Kingstons Hill, Surrey.

JACOBS (Red or Yellow).—1 and 2, R. Fulton. *hc*, S. Shaw. *hc*, J. Williams, Manchester. c. A. H. Stewart.

JACOBS (Any other colour).—1, E. E. M. Royds, Greenhill, Rochdale. 2, W. B. Van Haansbergen, Newcastle-on-Tyne.

FANTAILS (White).—1, J. F. Loversidge, Newark-on-Trent. 2, W. Choyce. 3, C. Bulpin, Riverside, Bridgewater. *hc*, Rev. W. Serjeantson; J. F. White; C. Bulpin (2). c. J. F. Loversidge.

FANTAILS (Any other colour).—1, J. W. Edge. 2, H. Yardley. *hc*, W. Choyce.

TRUMPETERS (Mottled).—1 and 2, E. Horner. *hc*, J. Frith. c. W. B. Van Haansbergen.

TRUMPETERS (Any other colour).—1, P. H. Jones. 2, W. H. C. Oates. *hc*, J. Hawley; J. Frith.

OWLS (Foreign).—1, J. Fielding, jun. 2, R. Fulton. *hc*, W. Harvey.

OWLS (English).—1, J. W. Edge, Birmingham. 2, E. D. Careless. *hc*, C. Bulpin; G. F. Whitehouse. c. S. A. Wyllie; J. Crossland, jun.

NEWS—1, W. Banks, Runcorn, Cheshire. 2, F. Graham, Birkenhead. 3, H. Yardley. *hc*, W. Robinson, Northwich.

TROTSITS (Red or Yellow).—1, O. E. Cresswell. 2, J. Fielding, jun. *hc*, S. Shaw, Halifax. c. J. W. Edge; H. Yardley.

TURBIS (Any other colour).—1, E. T. Dew, Weston-super-Mare. 2, W. Bankes. H. T. C. & E. Newbitt; W. Bankes. c. E. Horner.

BARDS (Black).—1, J. Frith. 2 and *hc*, R. Fulton. c. S. Shaw.

BARDS (Any other colour).—1, J. Frith. 2, R. Fulton. *hc*, J. Fielding; W. King, North, Surrey.

DRAGONS (Blue).—1, T. Waddington, Feniscowles, Blackburn. 2, F. Graham.

DRAGONS (Red or Yellow).—1, W. Gamon. 2, F. Graham. *hc*, J. Watts.

DRAGONS (Any other colour).—1, F. Graham. 2 and *hc*, H. Allison, Birmingham.

MAJORS—1 and 2, E. Horner, Leeds.

ANTWERPS (Silver Dun).—1, H. P. Ryland, The Redlands, Erdington, Birmingham. 2, H. Yardley, Birmingham. *hc*, H. K. Wright, Birmingham; E. Horner; H. Yardley.

ANTWERPS (Blue).—1 and Cup, W. H. Mitchell, Moseley, Birmingham. 2, H. R. Wright.

ANTWERPS (Red Chequered).—1, J. W. Ludlow, Birmingham. 2, H. K. Wright.

ANTWERPS (Blue Chequered).—1 and 2, J. W. Ludlow. *hc*, J. W. Ludlow; J. Crossland, jun.; H. Yardley; J. Williams, Manchester.

ARCHANGELS—1, W. Harvey. 2, C. Bulpin.

SWA LOWS—1, W. Choyce. 2, F. H. Paget, Birstall, Leicester. *hc*, E. Horner; J. Watts.

ANY OTHER NEW OR DISTINCT VARIETY—1, Rev. A. G. Brooks, Shrawardine, Salop; W. Bankes. 2, F. H. Paget; H. Allison. 3, F. H. Paget (2). *hc*, F. H. Paget; S. A. Wyllie.

CHIPPENHAM POULTRY SHOW.

This Show is always held in connection with a show for breeding and fat stock, coupled with one of the best competitions for cheese in the country. With the most excellent accommodation for a show of limited numbers it has for many years been remarkable for the perfection of the poultry entered. A few years ago its strength seemed to be centred rather in the useful breeds of poultry than the strictly fancy varieties now so much sought after by amateurs. Even to this show for Geese, Turkeys, and Ducks, few of even the most popular shows can contrive that at Chippenham, and the crossbreeds for table purposes were as well shown as heretofore.

This year, however, the *Game* fowls were of superior character, the *Buenos Ayrean Ducks* were extraordinarily good, and the *Dorkings* and *Cochins* were scarcely less commendable. *Hamburgs* were good, and the *Polands* shown by Mr. Hinton, of Warmistone, were among the most perfect we have seen for a long time past. A beautiful hybrid, bred between the wild English Pheasant and a *Game* hen, was one of the most attractive features to general visitors. From the weather proving most favourable, in the admissions at the gates this surpassed any former show.

DUCKINGS—1, Rev. J. C. Hoysted, Bradenstoke. 2, Miss J. Milward, Newton St. Loge. c. G. Hanks, Malmsbury; J. Butler, Tetbury.

SPANISH—1, G. Tonkin, Bristol. 2, G. Hanks. *hc*, R. C. Forster, Freshford.

GAME—Black-breasted and other Reds—1, W. H. Stagg, Netheravon. 2, O. Viveash, Berwick Bassett. *hc*, W. H. Stagg. c. E. Baily, Chippenham. *Any other variety*.—1 and 2, G. S. Sainsbury, Devizes. c. G. S. Sainsbury; E. C. Phillips, Brecon.

COCHINS—1, Miss Milward. 2, D. W. Thomas, Brecon. c. J. S. Maggs, Tetbury.

DORKINGS—1, W. Hanks, Somerset. 2, H. P. Moor, Langley Burrell. c. Rev. J. D. Hoysted (2); J. Kiogdon, Calne.

HAMBURGERS—Gold or Silver-pencilled—1, H. H. Thompson, Colehill. 2, T. Sealey, Somerset. c. J. W. W. Hubert, Chippenham. *Gold or Silver-spangled*.—1, C. Maggs, Melksham. 2, J. Powney, Calne. *hc*, J. Orledge, Chippenham.

POLANDS—1 and 2, J. Hinton, Warmistone.

BANTAMS—Game—1 and 2, Rev. F. Cooper, Amney Crucis. c. J. May, Southwell, Bristol; E. C. Phillips. *Any other variety*.—1, 2, and *hc*, Rev. F. Cooper.

ANY OTHER DISTINCT BREED—1, J. Hinton. 2 and *hc*, R. C. Forster, Freshford. c. J. S. Maggs.

CROSS BREED—1, J. S. Maggs. 2, D. Colleen, Chippenham. c. J. C. Fry, Marshfield; Mrs. W. A. Large, Cliftonav.

TURKEYS—1, Miss J. Milward. 2, H. Brinkworth, Corsham. *hc*, I. Smith.

GESE—1, G. Hanks. 2, J. Baker, Allington. *hc*, H. Say, Lacey (2). c. R. P. Rich, Chippenham.

DUCKS—Rouen.—1, J. S. Maggs. 2, J. C. Fry. *hc*, G. Hanks; G. M. Hulbert; c. G. Hanks; G. M. Hulbert; J. R. Kodnar, Aidwick Court, Wrington. *Aylesbury*.—1 and 2, G. Hanks. *hc*, J. S. Maggs. *Any other variety*.—1, G. S. Sainsbury. 2, G. Hanks. c. R. J. Fuller, Bremhill.

SWEETSTARE (Game Cock),—1 and *hc*, W. H. Stagg. 2 and 3, G. S. Sainsbury.

Mr. Edward Hewitt, of Birmingham, was the Judge.

OKAHM POULTRY SHOW.

The weather during this Show was unfavourable to the attendance of visitors, as well as to the poultry exhibited, for although it was stated in the printed catalogue that the exhibition was to be held in the Riding School, all except the Pigeons and Bantams, which had the shelter of a large barn, were placed under a large tent, through which the rain penetrated so much as to make it a question whether it was any protection or not. The only difference at first sight was that a portion of the birds were perfectly dry, whilst others were subjected to even a greater downpour than had they been shown without any covering whatever. Tents are never to be depended upon at this season, and we trust that on future occasions an improved plan may be resorted to, as, certainly, the high value of most of the birds shown demanded more favourable quarters. Considerably more than five hundred pens of poultry and Pigeons were in themselves a very good collection; many of our first-rate exhibitors were competing, and the show pen of Messrs. Turner, of Sheffield, left nothing that could be bettered on that head.

It is beyond question that the Rutland Show just held contained by far the best collection of *Cochins* that has ever been seen in the district; Partridge, Buff, and White proving excellent. The *Game* classes were remarkably good, the Brown Red cocks and Ducking Game hens being of far higher merit than usual. Some very well matched Pekin Bantams were shown, and we noticed some first-rate *Malays* and *Silky* fowls. *Turkeys* were far beyond the average, and in the *Duck* classes were to be found contributions from the best breeders in the kingdom. The Selling class was one of more merit by far than usual, a silver cop for the best pen causing first-rate specimens to be entered. It was taken by a well-shown young White Cochins, which will probably again secure similar trophies. *French* fowls were entered in far larger numbers than have been hitherto known in Rutland, and most of them were excellent. It is impossible to give more than a very rough estimate of the *Hamburghs*, as they were so perfectly saturated in some instances that the markings were indistinguishable. The *Pigeons* were a fine collection, and had, as before said, luck on their side, being secure from cold draughts and driving rain. We are assured that the Riding School, or some similar building, will be secured for future *Okahm* shows.

DORRINGS.—Coloured.—Cock.—1 and Cup, C. Speed. 2, E. Wood, Clapton. Thrapsen, J. Hornshy, Grantham; J. Stott, Healey, Rochdale; Marchioness of Exeter, Burghley Park, Stamford; J. Longland, Grendon (2); H. Lingwood, Barking, Needham Market (2); J. M. Wellington, Okahm, c. G. A. Crewe, Etwell, Derby. Hens or Pullets.—1, H. Lingwood. 2, L. Patton, Hillmore, Taunton. *hc*, Lady Aveland, Okahm; J. Hornshy; R. Wood; J. Stott. Silver.—Hens or Pullets.—1, O. E. Cresawell, Hanworth Rectory, Feltham. 2, J. Longland. *hc*, D. E. Campbell, Brentwood, c. Marchioness of Exeter; Mrs. Lowther, Barleythorpe Hall, Okahm. White.—Cock.—1, Miss E. Williams, Henllys Berriew, Montgomeryshire. 2, C. Boye, Kettering. *hc*, Marchioness of Exeter. Hens or Pullets.—1, Miss E. Williams. 2, Marchioness of Exeter, *hc*, Marchioness of Exeter; O. E. Cresawell. SPANISH.—Black.—1, J. F. Dixon, Cotgrave, Nottingham. 2, J. F. Sillitoe, Wolverhampton. *hc*, H. J. Wilkinson, Earby. Chickens.—1 and Cup, J. Boniton, Boreham. 2, J. F. Dixon, Cotgrave, Nottingham. *hc*, H. Yardley, Birmingham; J. F. Sillitoe; H. Walker, Kettering. WOLVERHAMPTON. COCHIN-CHINA.—Cinnamon, Buff, or Partridge.—Cock.—1 and Cup, R. B. Wood, Uttoxeter. 2, T. Rogers, Walsall. *hc*, H. Lingwood; W. A. Taylor, Manchester; C. Sidwick, Ryddesden Hall, Keighley; J. M. Wellington; G. A. Crewe. c. Horace Lingwood, Croeting, Needham Market; H. V. Storey, Lockington, Derby. Hens or Pullets.—1, J. Cattell, Birmingham. 2, W. A. Taylor. *hc*, H. Lingwood; Mrs. Woodcock, Rearsby House, Leicester; H. Lingwood; W. A. Burnell, Kettering; H. Derry, Gedney; J. K. Fowler, Aylesbury; H. V. Storey. c. T. Rogers, Walsall. Black.—Cock.—1, Mrs. A. Williamson, Queenborough Hall, 2, H. H. Bletsoe. 2 and *hc*, Mrs. A. Williamson. Hens or Pullets.—1, H. H. Bletsoe. 2 and *hc*, Mrs. A. Williamson. BRAHMA POOTRA.—Cock.—1, W. Adams, St. Clement, Ipswich. 2, W. T. Storer, Shull Green, Brewood. *hc*, W. A. Taylor. c. J. Thomson, Sheffield; Mrs. A. Williamson. Hens or Pullets.—1, W. Adams. 2, Rev. D. Peake, Laleham Staines. *hc*, Mrs. A. Williamson. FLEMISH FOWLS.—1 and Cup, C. H. Smith, Radcliffe-on-Trent (Crève-Cours), 2, J. K. Fowler (Houdans). 3, W. Dring, Faversham (Houdans). *hc*, J. Maiden, Biggleswade (Crève-Cours); Mrs. J. Cross, Appleby Vicarage, Brig (Crève Cours); R. B. Wood (Houdans); M. Kew (Houdans). c. J. Maiden (Crève-Cours).

HAMBURGH.—Silver-spangled.—1, C. Parsons, Wolverhampton. 2, G. Walters, Worcester. *hc*, J. Wright, Melton Mowbray. Silver-penciled.—1, T. Hambleton, Keighley. 2, W. Golly, c. Co., Duhb, Bingley. Gold-spangled.—1 and Cup, T. Hambleton, Tottenham. 2, W. Golly, c. Co., Duhb, Bingley. *hc*, W. K. Tickner, Ipswich; L. Wren, Lowestoft. Golden-Cuckoo.—1, R. R. Parker, Ipswich. 2, W. K. Tickner. *hc*, A. Coles, Long Sutton, Wisbeach. c. H. Marriott, Skirbeck, Boston.

GAME.—Red and other Dark Colour.—Cock.—1, W. Adams. 2, A. J. Flyder, *hc*, A. J. Flyder; F. Bell, Burton-on-Trent; S. Matthew, Stowmarket. c. T. H. Heafford, Melton Mowbray; G. Heafford, Loughborough (2). Hens or Pullets.—1, G. Heafford. 2, W. J. Jones, Barleythorpe Hall. *hc*, Messrs. Collyer and Co., T. Whitaker, W. J. Jones, Barleythorpe Hall. *hc*, Messrs. Collyer and Co., T. Garton, Okahm. White Piles, and Light Colour.—Cock.—1, S. Matthew. 2, E. Winwood, Worcester. *hc*, T. Whitaker; G. Heafford; J. Jekin. Hens or Pullets.—1 and Cup, S. Matthew. 2, E. Winwood.

BANTAMS.—White, clean legs.—1, B. Painter, Burley-on-the-Hill. c. S. & R. Ashton, Mottrick; H. L. Bradshaw, Wakerley, Stamford. Black, clean legs.—1 and Cup, S. M. Storer, Long Sutton. 2 and *hc*, E. Ashton. Gold or Silver-laced.—1, H. Draycott, Hambro, 2 and *hc*, H. H. Bletsoe. *hc*, Mrs. M. Finch. Any other Variety.—1, B. S. Lowndes, Stony Stratford (Pekin Bantams). *hc*, Mrs. Woodcock, Leicester. 2, E. Winwood, Worcester (White-bodied Bantams). H. S. Moscrop. 2, G. Hall, Kendal. *hc*, T. Whitaker, Melton Mowbray; Rev. E. S. Toddman, Childerley Vicarage, Brentwood; W. Knight, Maplebeck, Newark; W. C. E. Newbitt, Epworth; F. H. Jones, Fulham. c. E. Barker, Stokely. Hens or Pullets.—1, B. S. Lowndes, Stony Stratford; H. H. Bletsoe, c. J. Jekin, Pagnell. *hc*, Rev. E. S. Toddman. 2, H. C. Rogers, Newport. 3, J. G. Jeffrey. c. J. Smith, E. Lingley Hill, Southwell; H. Ashmore, Brimington, Chesterfield; J. M. Wellington, Okahm.

POLANDS.—1, G. W. Boothby, Louth. *hc*, A. Almond, Oakham. c. A. Almond; M. Kew.

ANY OTHER VARIETY.—1, M. Kew (Malays). 2, Miss E. J. N. Hawker, Turleigh, Tadbrough Wells (Japanese Silkies). TURKEY.—Old Bush.—Cock.—1 and Cup, G. R. Pearson, Witham Common, Grantham. 2, L. Patton, Hillmore, Taunton. *hc*, G. R. Pearson; — Hughes; F. E. Richardson; M. Kew; Misses G. & L. Traish, Potheringham, Oundle; Mrs. A. Guy, Eaton, Grantham; E. Leech, Rochdale, c. F. Palmer; Marchioness of Exeter. Hens.—1, Mrs. A. Guy. 2, G. R. Pearson, *hc*, L. Patton; M. Kew. c. F. Palmer; E. J. Richardson, Bramshall, Uttoxeter. Young Birds.—Cock.—1, Mrs. A. Mayhew, Great Baddow. 2, G. R. Pearson. *hc*, W. Hughes; Mrs. A. Guy. c. G. R. Pearson; E. Leech. Hens.—1, G. R. Pearson. 2, F. Leech. *hc*, L. Patton; W. Hughes.

DUCKS.—White Aylesbury.—1, Mrs. C. P. E. Leech. 2, Mrs. M. Seamons, Aylesbury. *hc*, Mrs. M. Seamons; S. Deacon, jun., Polebrook Hall, Oundle; J. K. Fowler, Aylesbury; H. H. Bletsoe. c. G. H. Finch, M.P. (3). Rouen.—1, J. W. White, Netherton. 2, Mrs. M. Seamons. *hc*, L. Patton; J. W. White; J. Dickinson, Leigh, Manchester. c. R. Wood. Any other Variety.—1, Mrs. Louthers (East Indian). 2, H. H. Bletsoe, Barwell, Oundle (Wild). *hc*, S. H. Stott; H. C. Deacon, jun. (East Indian). White Peruvians. c. M. Kew (Buenos Ayres); S. Deacon, jun. (East Indian). Cross-bred or Common.—Young.—1 and *hc*, C. J. Bradshaw. 2, G. R. Pearson.

GESE.—Pure White.—1 and Cup, Mrs. M. Seamons. *hc*, E. Leech. Goslings.—1, J. K. Fowler. *hc*, G. H. Finch, M.P. (2). Grey.—1, Rev. C. H. Lucas, Edith Weston, Stamford. *hc*, M. Kew. c. S. H. Stott; E. Leech. Goslings.—1, E. Leech. *hc*, J. K. Fowler. c. Rev. C. H. Lucas; S. Deacon, jun. SELLING CLASS.—1 and Cup, T. Rogers, Walsall. 2, J. F. Sillitoe, Wolverhampton (Spanish Cocks). *hc*, J. Longland, Grendon, Northampton (Dorking Pullets); W. B. Jeffries (Bantam); G. Boye, Kettering (Dorkings); Mrs. Burridge, Burley-on-the-Hill (Ira Fowls); J. K. Fowler (Aylesbury Ducks). c. J. F. Sillitoe (Spanish Cocks); W. Dring (Crève-Cours); J. M. Wellington (Black-breasted Reds); L. Wren, Lowestoft (Golden-spangled Hamburgh Cocks); W. A. Burnell (Buff Cochins Pullets); G. A. Crewe (Partridge Cochins).

LOCAL CLASSES.

DORRINGS.—Chickens.—*hc*, C. Speed, Exton; G. H. Finch, M.P., Burley-on-the-Hill. GAME.—Chickens.—Cup, A. J. Flyder, Aylesbury Hall Uppingham. FARMYARD.—Chickens.—1 and 2, M. Kew. 3, B. Painter, Burley-on-the-Hill.

PIGEONS.

TOMBELERS.—1, H. Yardley, Birmingham. 2, P. H. Jones, Folham. *hc*, G. Brentland, Burton-on-Trent. c. H. Headley. CARRIERS.—1 and 2, E. Walker, Leicester. c. H. Yardley. POUTERS.—1, W. R. Rose, Kettering. 2, E. Walker. *hc*, R. F. Payling, Peterborough. JOHNS.—1 and 2, H. Headley, Thurmaston, Leicester. CANTAILS.—1, J. F. Lovelace, Newark-on-Trent. 2, F. H. Paget, Birkstall, Leicester. *hc*, H. Vaughan, Wolverhampton; P. H. Jones, Folham. c. H. Yardley, Birmingham. TRUMPETERS.—1, Withheld. 2, W. Gamble, Thorpe Satchville, Melton. NUNCS.—1, P. H. Jones. 2, H. Vaughan. *hc*, W. E. Easton, Hull. c. A. B. Bagley, Shooter's Hill, Longton. SHARPS.—1, P. H. Jones. 2, W. E. Easton. *hc*, O. E. Cresawell; F. H. Paget. c. A. B. Bagley. KENTS.—1, H. Yardley. 2, T. D. Green, Safron Walden. c. H. Yardley; P. H. Jones. ANY OTHER VARIETY.—1, H. Yardley. 2 and c. F. H. Paget. *hc*, H. Headley (Labels).

The Judges were Mr. Hewitt and Mr. Tegetmeier,

NORTHAMPTON ORNITHOLOGICAL SOCIETY

This Society's Show of Canaries, British birds, and Pigeons, was held November 26th and 28th. The following are the awards:—

PIGEONS.—Three of Distinct Varieties.—1 and Cup, Mrs. Hall, Northampton. 2, W. Nottage, Northampton. c. T. Chambers. Pouters or Carriers.—1 and c. T. Chambers, jun., Northampton. 2, T. Adams, Northampton. *hc*, B. B. Farber, Northampton. 1, W. Morbey. 2, W. Nottage. *hc*, C. Tassell, Northampton. Orls, Turbits, or Jacobins.—1, W. Morbey, Northampton. 2, W. Lepper, Northampton. *hc*, F. Farber, Northampton; W. Lepper. Any other Variety.—1, W. Lepper. 2, W. Morbey. *hc*, Green, Northampton.

CANARIES.

NEWBORN.—Clear Jonque.—1, T. Irons, Northampton. 2, Moore & Wynne, Northampton. *hc*, T. Mann, Cannewell New Road; Bemrose & Orme, Derby. *hc*, T. Irons; G. Gayton, Northampton; W. Gamble, Northampton. c. S. Bunting, Derby; Moore & Wynne (2). Clear Mealy.—1, Moore & Wynne. 2, Bemrose & Orme. *hc*, S. Bunting; Chapman. *hc*, Moore & Wynne; Bemrose & Orme. c. G. Clifton, Northampton; Moore & Wynne. Equal 2, R. Hawley, Derby. Evenly-marked Jonque.—1, W. Gamble. 2, T. Irons, Northampton. *hc*, Bemrose & Orme, H. A. Apled, Worthing; J. Bexson, Derby. c. S. Bunting; T. Irons. Evenly-marked Mealy.—1, Moore & Wynne. 2, G. Gayton. *hc*, Moore & Wynne; Bemrose & Orme. *hc*, W. Gamble. c. H. Apled; J. Bexson.

NEWBORN.—Ticked or Unevenly-marked Jonque.—1, Bemrose & Orme. 2 and *hc*, Moore & Wynne. *hc*, T. Mann; R. Hawman; c. H. Apled; T. Irons. *hc*, Bemrose & Wynne; Bemrose & Orme. *hc*, H. Apled; W. Gamble.

NEWBORN.—Any variety of Crested Jonque.—1, R. Hawman. 2, T. Irons. *hc*, Moore & Wynne; T. Irons. *hc*, Moore & Wynne; W. Barwell, Northampton. c. J. Turner, Birmingham; G. Smith, Northampton. Any variety of Crested Buff.—1, T. Irons. 2, J. Turner. *hc*, S. Bunting; T. Irons. *hc*, Cox; T. Irons. c. W. Holmes, Nottingham; — Hyllier.

NEWBORN.—Clear Yellow.—1, J. Turner. 2, J. N. Harrison, Belper. *hc*, S. Spinke, Chippenham; J. N. Harrison. c. W. Neidler, Hull; J. Close, Derby. *hc*, S. Spinke. 1, J. Turner. 2, W. Bexson. *hc*, S. Spinke (2). *hc*, J. N. Harrison. Marked or Variegated.—1, J. Turner. 2, S. Spinke. *hc*, S. Bunting. c. J. N. Harrison.

LIZARDS.—Golden-spangled.—1, T. W. Fairbairn, Canterbury. 2, G. Tuckwood, Northampton. *hc*, J. N. Harrison; Stevens & Burton, Middlesbrough. *hc*, T. W. Fairbairn; H. Ashton, Polefield Hall, Prestwick. c. Stevens and Burton. H. Hawman, Silver-spangled.—1, H. Ashton. 3, Stevens & Burton. *hc*, R. Hawman; Stevens & Burton. *hc*, S. Bunting. c. G. Tuckwood; J. N. Harrison.

CINNAMON.—Jonque.—1, 2, and *hc*, T. Irons. *hc*, — Tomes; S. Bunting; G. Clifton. c. Moore & Wynne; H. Apled. Buff.—1 and *hc*, T. Irons. 2, W. Gamble. *hc*, H. Apled; — Tear, Northampton. c. W. Gamble; H. Apled. Marked or Variegated.—1, Stevens & Burton; 2 and c. Moore & Wynne. *hc*, — Tomes.

ANY OTHER VARIETY.—1, H. Ashton. 2, A. Webster, Kirkstall, Leeds. *hc*, G. Gayton; W. Hutton, Baidon. *hc*, W. Holmes; — Tear, Northampton; W. Hutton. c. Stevens & Burton; H. Ashton.

GOLDFINCH MULE.—Jonque.—1 and 2, B. Ashton. *hc*, Stevens & Burton; W. L. Chapman; W. Neidler. Mealy.—1, Fairclough & Howe. 2, S. Bunting. *hc*, W. C. Burniston, Middlesbrough; S. Bunting. *hc*, H. Ashton (2). c. W. Neidler; W. L. Chapman. Dark.—1, Moore & Wynne. 2, Cox. *hc*, Stevens & Burton; Moore & Wynne. *hc*, W. Cattell, Northampton; A. Webster; W. L. Chapman. c. Cox; — Hyllier.

GOLDFINCH.—I, Fairclough & Howe, vnc. J. N. Harrison; Stevens & Burton, nc. W. King, Wellingborough. c. Moore & Wynne; — Knibb.
BULLFINCH.—J. W. & C. Barniston, vnc. F. Haddon, Northampton; Fryer and McCrae, Stockton. nc. Moore & Wynne. c. A. Webster.
JUDGE.—Mr. W. Wilmore, London.

EGG-EATING BEES.

THE fact of bees eating or removing eggs from their combs when queens are being reared artificially, as described by your correspondent "R. S." in page 383, has been noticed by me for a number of years, and I once sent an article on the subject to the Journal, but for some reason it never appeared. I have, however, experimented much both before and since on this point, and may here describe under what circumstances I have found the egg-eating propensity become manifest, and show also how I have cured it. Like "R. S.," I am prepared to say that it often happens, but I do not believe that it occurs in every instance.

Many bee-keepers, I doubt not, have noticed during spring the case of a formerly-proven fertile queen where the hive in which she is regnant makes no progress, no young bees appearing, and yet if this queen were transferred to another hive it would at once become prosperous. When I made this discovery I noticed that in such dwindling hives where they had taken to egg-eating the bees were invariably old. Knowing, therefore, the fact that if the queen were transferred to another hive her progeny would be matured, I tried the experiment of inserting a frame of brood in the heart of the hive; this had the desired result and acted like a charm, and I have often since repeated the experiment with success. Subsequently, when I discovered that eggs and larvæ were eaten by the bees when raising queens, I conjectured and was about to affirm that bees required eggs or larvæ for the production of royal jelly, but I exploded this idea, having found from further experiments that many destroyed not a single egg.

Although I am satisfied that eggs are not invariably destroyed, still the mystery is far from being solved. I may, however, be allowed to ask the question, What is the reason that old bees devour eggs and that young ones do not? Can it be owing to their stomachs? We know there is a difference in the stomachs of the old and young of some animals; can there then be an inability in the stomach of the old bee to produce royal jelly? and is that organ in the young bee, whose duty it appears to be to become a nurse when but a few hours old, capable of producing a different compound from that of old ones?—A LANARKSHIRE BEE-KEEPER.

BEEES BREEDING LATE.

YESTERDAY, November 30th, being a very warm and fine day, my bees all turned out in numbers, and upon inspecting one of the hives I was astonished to see a number of young bees before the entrance, evidently just come out of their cells. Now you will allow this is rather an unusual time of year for young bees—either exceedingly early or very late, and as there is no chance of there being any pollen for two months at least, I wish to know what will become of any grubs there may be in the cells, and whether there is any means of providing artificial pollen, such as meal, what is the best way to give it to them, and the best to use?—CAROLUS.

[Your bees have been breeding late in the season, but this circumstance is not so remarkable as you appear to imagine. Young bees (Ligurians) were taking wing for the first time in considerable numbers from one of our own hives five days later than in your case, whilst pollen was being carried into others at the same time. You need not apprehend any failure in the supply of the last-mentioned substance, which we have always found bees able to accumulate in excess of their actual requirements.]

OUR LETTER BOX.

NOTICE.—Most of our authorities are at Birmingham, so that we must defer answering many poultry queries until our next number.

HAMBURGH (S. D. C.).—It is pronounced as if spelt "Hamborough." A dark pullet, though lighter-plumaged this season, is not unlikely to produce dark chickens next year. We do not know anything about the preferences you name.

BLACK-BREADED RED GAME MOULTING UNTRUE TO COLOUR Puzled One).—It is not very uncommon for a bird to moult as you describe yours to have done. If you exhibit, he is still fit to show in the class for "Black-breasted and other Reds." He will not do for Black-breasted Reds. He is now a Brown Red, but not less valuable. There is a stain in him to which he has thrown back.

FEEDING BRAHMAS FOR EXHIBITION (A Duffr).—We like your feeding

better than the advice of your friends. If your fowls have good constitutions do not destroy them with physic. Give them ground oats slaked with milk in the morning, a little barley or maize at midday, and ground oats again in the evening; add thereto some table scraps daily, and some heavy sods of growing grass cut with plenty of fresh mould. Give as much lettuce as you please. You need do nothing more.

FEEDING POULTRY (Poultry Food).—Ground oats are excellent food, but not essential to the well-doing of fowls. Feed as we have advised in our preceding answer, substituting barley meal for ground oats. (A Ten-years Subscriber).—It is almost impossible to name any quantity of food for a given number of poultry. Your food is not good; instead of Indian corn meal, give ground oats, which in Ireland you should get cheaper. The Ducks should be fed on oats, the Turkeys on meal mixed with milk. It will always be difficult to fatten chickens, Ducks, or Turkeys brought from cottagers, as they are so poorly fed. As a rule, that which is necessary for the formation of the fat, is for a long time absorbed in the production of flesh. We advise you to let all the chickens run at liberty, to shut up the Turkeys in a small shed where they can be fed from a trough with fo-d made of oatmeal slaked with milk; but they must be put up as they are likely to be wanted, two or three at a time. The Ducks should be shut up in an old pig-sty or similar place, and fed on oats put in a trough with water. You must recollect birds cannot be kept artificially fattened in a state of confinement. They will lose flesh and die. We advise you to shut up only Ducks and Turkeys. Feed the chickens as well as you can at liberty. You will never get eggs in the winter by keeping hens, you must have pullets for that purpose. Birds will starve to death on one food, however good it may be. They must have change. Most poultry women waste half the food by throwing down the same quantity in the same place every day without reference to circumstances. To throw down food, is not to feed. When the first is only partly eaten, the second should not be given. Fowls do not like Indian meal, nor is it profitable food. It would be a much better arrangement for the poultry woman to buy her own food. In a large family the scraps, properly managed, should play an important part in feeding the birds, and lessening the expense.

EXHIBITING SPANISH FOWLS—COCHIN UNTHRIVING (Scotus).—The small defect in the face of your Spanish cock being an accident, and bearing the proof of it, will not be a disqualification. It is only a disadvantage, and not a serious one. The White Cochins are unwell. He must be thoroughly purged with castor oil, a table-spoonful every day till his evacuations, which are, doubtless, now green and watery, become figured and brown and white. If after some days' purging this does not take place, try Baily's pills, and add to them two pills of camphor, each the size of a garden pea. These may be given with castor oil, allowing two hours between the oil and camphor. If benefit show itself, the dose of camphor may be increased.

FATTENING FOWLS FOR TABLE (N. C.).—Cramming is unnecessary, unless it is desired to make fowls fit for the London market. Fowls can be kept fat enough for table when running about, and always are so in a good farmyard; but where all the food has to be bought it is very expensive to feed all alike. The birds intended for the table should be shut up in a fattening coop, and fed three times per day with ground oats or barley meal mixed with milk. The process is too long to be described here, you will find it at length in "Fowls," by Baily. In that work there is a chapter devoted to it.

PIGEONS AND CHAFFINCH (E. S. Polkinghorne).—Your Pigeons have roun; we gave the most likely means of cure in our number for November 17th. A great number of articles appeared in this Journal in the early part of this year about Flying Tumblers and Birmingham Rollers, and more, alas! was said of them than was true, both as to length of flight and supposed delicacy. In the words of Mr Breat, "Flying Tumblers give less trouble in breeding than any other variety of Pigeon, where any pretension to fancy is desired." In the long articles we printed the subject was exhausted. The tauneness of your Chaffinch is as pleasing as it is unusual.

FISH IN GLASS GLOBE (H. H.).—Give them a little raw meat shredded very fine every day. Vallisneria spiralis, Rannunculus aquatilis, and Apongetoo distachyon are plants you might grow in the globe.

PICKLED MUSHROOMS—"C. Y." has pickled mushrooms; all turned black. She wishes to know how this is caused and to be avoided.

METEOROLOGICAL OBSERVATIONS

In the Suburbs of London for the week ending November 29th.

DATE.	BAROMETER.		THERMOMETER.				Wind.	Rain.
	Max.	Min.	Air.		Earth.			
			Max.	Min.	1 ft.	2 ft.		
Wed. . . 23	29.414	29.188	58	34	48	44	S.W.	.12
Thurs. . 24	29.339	29.202	59	48	50	45	S.	.24
Fri. . . . 25	29.641	29.327	60	31	47	45	S.	.02
Sat. . . . 26	29.919	29.765	57	31	47	45	S.	.00
Sun. . . . 27	30.275	30.137	48	39	48	46	S.E.	.00
Mon. . . . 28	30.227	30.177	54	27	46	44	S.E.	.00
Tues. . . . 29	30.217	30.175	48	39	45	45	S.E.	.00
Mean. .	29.853	29.710	54.86	35.57	47.43	44.86	..	0.88

- 23.—Foggy; very fine; fine, starlight.
- 24.—Boisterous; very fine; drizzling rain.
- 25.—Clear and fine; cloudy; fine starlight.
- 26.—Dense fog; very fine; dense fog.
- 27.—Cloudy but fine; very fine; dense fog.
- 28.—Foggy; dense fog; densely overcast.
- 29.—Densely overcast; overcast; densely overcast.

COVENT GARDEN MARKET.—NOVEMBER 30.

THERE has been a limited attendance of buyers during the week, and a general dullness prevails. Hothouse Grapes are good and plentiful, comprising Black Hamburgs, Alicante, Lady Down's, and Muscats, Pines are as plentiful as they were scarce at the beginning of the month, and prices are receding. Large supplies of Potatoes have come to hand both coastwise and by rail.

WEEKLY CALENDAR.

Day of Month		Day of Week		DECEMBER 8-14, 70.			Average Temperature near London.			Rain in last 43 years.	Sun Rises.		Sun Sets.		Moon Rises.		Moon Sets.		Moon's Age.	Clock after Sun.		Day of Year.
							Day. Night. Mean.			Days.	m. h.		m. h.		m. h.		m. h.		Days.	m. s.		
8		Th		46.0	33.6	40.3	19	54	af 7	50	af 3	24	af 4	55	af 7	0			7	54	842	
9		F		46.7	34.9	40.8	17	56	7	50	3	4	5	56	8	16			7	27	843	
10		S		47.0	32.8	39.9	26	57	7	49	3	5	5	50	9	17			7	0	844	
11		SN	3 SUNDAY IN ADVENT.	46.5	32.6	39.5	17	58	7	49	3	5	5	50	16	18			6	32	845	
12		M	[of Gardeners.	45.0	37.0	42.5	18	59	7	49	3	1	8	15	11	19			6	4	846	
13		Tu	Royal Horticultural Society's examination	47.5	36.5	42.0	23	0	8	49	3	13	9			21			5	36	847	
14		W	Meeting of Royal Microscopical Society.	46.0	34.3	40.6	21	0	8	49	3	27	10	12	0	21			5	8	848	

From observations taken near London during the last forty-three years, the average day temperature of the week is 47.1, and its night temperature 34.5. The greatest heat was 63°, on the 11th, 1841; and the lowest cold 13°, on the 8th and 19th, 1867. The greatest fall of rain was 1.92 inch.

PRUNING ORNAMENTAL TREES AND SHRUBS.

No. 6.



PRUNING being subsequent to planting, I purpose at this stage to offer to the notice of intending planters some suggestions on the distribution of trees and shrubs in parks and pleasure grounds.

The best and the true mode of arranging trees, shrubs, and other plants so as to produce effect is, without dispute, massing them. Art may dispose them in lines and a variety of ways that will result in a good effect, but

though art is essential it will ever prove abortive if not founded on those broad, well-defined principles that give art its life. The ideal of the painter is Nature. If his picture has not Nature it will never immortalise him, and the planter disposing plants in a confused manner will have a very confused, undefined landscape. Some have an idea that the best effect is attained by a promiscuous assemblage of the different species and varieties of trees, shrubs, and other plants. Probably acting on what they consider Nature's disposition, at irregular distances and in an irregular style, a great diversity of plants are placed in a manner which is in no way superior to a confused distribution that in the end must produce a bad effect. This is termed imitating Nature. As a mixture the planting may be all very well; it may serve every purpose of shelter, and afford the gratification trees and shrubs with their allies always give, but it has nothing of Nature, for in this the trees, &c., form objects in the landscape; there are masses of evergreens in one spot, and masses of deciduous subjects in another, the whole having varied gradations of height, depth, and size; uniformity is nowhere apparent, and yet the whole is blended into one scene or picture, though composed of several parts or objects individually well marked and distinct, yet bearing a correlation to each other, producing in effect that harmony and contrast most pleasing to the eye.

Nature's principle of planting is in masses. In no case is Oak intermixed with Ash, much less do we find a clump of Pines mingled with Elms. The soil, situation, and climate give a degree of fitness for a certain class of plants in one place, and for a very different kind in another; hence we have that distinctness of view with diversity of features always pleasing to the eye, and a completeness that characterises Nature's works, showing them different from art or the work of man. Though in the best examples of natural scenery there is seldom the solitary tree, yet there is a very great difference in the subjects forming the landscape. A mass of Oak prevails in one place, there is Ash or Elm in another, Pines surmount the eminences, Gorse will show itself here and there, the Willow will be where there is water, the Dog-wood and Guelder Rose in moist situations, and in all there are masses of some particular tree; not that there are no detached specimens and small groups, but they seem rather as having escaped from the main groups, forming connecting links between the latter and what they

adjoin, than as being characteristic of Nature's disposition of plants.

I will not further note Nature's distribution of plants. It has been pooh-poohed in our gardens, but what would be said if we were to mix our flowering plants in beds and borders in a style like that we adopt in ninety-nine out of every hundred plantations of trees that are formed in this country? Supposing we arrange our plants in a bed or border one or more of each kind, having due regard to height and colour both of bloom and foliage, striving to make a bed as much mixed or diversified as possible, what will be the result? A fine bed it may be as regards foliage and flowers, but the effect is poor. What a different effect would have been produced had all the plants of one hue of flower or foliage been disposed in a mass! The parts then become distinct—a feature in itself, though it comprises but a part of the bed or border, yet combining with the other parts to form a whole. It is the same with trees, though on a larger scale; the mixed system must give place to the massing or natural system.

In planting trees and shrubs on the massing principle groups may be formed of one species or variety of tree, or very effective groups may be formed of a species and its varieties, and finer still when the most distinct species of a genus are collected into a group; in no case mixing them promiscuously, but disposing each in a mass, so as to show its character, and by dotting a few on the margin of the group, yet near enough to form or appear a part of the group at a distance, though on close inspection they have the characteristics of the isolated tree. In this way we secure the beauty of the specimen as well as that of the mass. The dotting will also serve to break the not unfrequently monotonous smoothness of artificial outlines.

The groups may comprise any number of parts—in extensive arrangements be large enough to contain examples of every species and variety of a genus; but very effective groups may be formed of a few of the most distinct kinds.

Let us suppose *a* to be a group intended for three species or kinds. Oaks are desired. In this case—*a*, Turkey Oak (*Quercus Cerris*); *b*, English Oak (*Quercus pedunculata*); *c*, Scarlet Oak (*Quercus coccinea*); whilst for dotting on the margin the same kinds may be employed as those in the mass adjoining; or *e* may be the variegated Lucombe Oak (*Quercus Cerris Lucombeana variegata argentea*); *d*, Lucombe Oak (*Quercus Cerris Lucombeana*); *f*, Fern-leaved variety of the English Oak (*Quercus pedunculata asplenifolia*); *g*, Variegated English Oak (*Quercus pedunculata variegata*); *h*, Cork Oak (*Quercus Suber*); *i*, Evergreen Oak (*Quercus Ilex*).

In a similar way with Chestnuts, *a*, may be the common Horse Chestnut (*Aesculus Hippocastanum*); *b*, Pink Horse Chestnut (*Aesculus H. carneum*); *c*, Scarlet Horse Chestnut (*Aesculus H. coccineum*); whilst *d* could be the Variegated (*Aesculus H. variegatum argenteum*); *e*, Double White Horse Chestnut (*Aesculus H. flore-pleno albo*); *f*, Double Red (*Aesculus H. flore-pleno rubro*); *g*, *Aesculus H. præcox*; *h*, *Aesculus H. crispum*; *i*, *Aesculus rubicandus*.

In a similar way it might be planted with Elms, Limes,

Maples, &c., and so on to evergreens: for instance Pines, *a*, Austrian (*Pinus austriaca*); *b*, *Pinus excelsa* or Weymouth (*Pinus Strobus*); *c*, Corsican (*Pinus Laricio*), or Scotch (*Pinus sylvestris*); and *d*, *Pinus Cembra*; *e*, *Pinus Benthamiana*; *f*, *Pinus macrocarpa*; *g*, *Pinus Lambertiana*; *h*, *Pinus Jeffreyi*; and *i*, *Pinus pyrenaica*.

Spruce Firs form an imposing group; as *a*, Norway Spruce (*Abies excelsa*); *b*, Douglas (*Abies Douglasii*); *c*, White Spruce (*Abies alba*); then *d*, *Abies excelsa elegans*; *e*, Hemlock Spruce (*Abies canadensis*); *f*, *Abies Menziesii*; *g*, *Abies orientalis*; *h*, *Abies Douglasii taxifolia*; *i*, *Abies Hookeriana*.



Silver Fir would be even finer. *a*, *Picea Frazerii*; *b*, *Picea peetinifolia*; *c*, *Picea lasamea*; and *d*, *Picea Nordmanniana*; *e*, *Picea cephalonica*; *f*, *Picea nobilis*; *g*, *Picea Pinsapo*; *h*, *Picea grandis*; and *i*, *Picea magnifica*.

If not convenient to have groups of one genus, very effective masses would be formed by planting different species or varieties of several genera. For instance, 1 may be composed of Beech; 2, Scotch Fir; 3, White American Spruce; 4, Scarlet Oak; 5, Scotch Elm; 6, Scarlet Maple; 7, Lime; 8, Austrian Pine; 9, Sycamore; 10, Horse Chestnut; and for dotting, *d*, Purple Beech; *e*, Turkey Oak; *f*, Scarlet Horse Chestnut; *g*, Variegated Sycamore; *h*, Variegated Maple; *i*, Exeter Elm.

In case it were near the pleasure grounds it might be desirable to employ shrubs, then 1 may be *Cupressus Lawsoniana*; 2, common Holly, with Mountain Ash interspersed among the Hollies at about 15 feet apart; 3, Portugal Laurel; 4, English Yew; 5, *Laurustinus*, with a few *Laburnums* at the back and interspersed; 6, *Thujopsis borealis*; 7, *Coldie Laurel*, with Bird Cherry interspersed; 8, *Rhus Cotinus*, with *Berberis Aquifolium* and *B. Darwinii* in masses in front, or just within the margin; 9, Lilacs, with a mass of tree Box at the right-hand corner; 10, *Thuja Lobbi*; and *c*, *Scarlet Thorns*; *d*, *Double Gorse*; *f*, *Salisburia adiantifolia*; *g*, *Double White Thorns*; *h*, *Tulip tree*; *i*, *Scarlet Thorns*.

The above may not be the best modes of arrangement, nor are they given as such, but any mode of planting is better than a confused one; they may lead to better modes of planting in future, for I cannot perceive anything more at variance with our ideas of the beautiful than what we meet with in nearly all parks adjoining pleasure grounds in the three kingdoms.—G. ABBEY.

THE PINE APPLE.

THE summer of 1870 has been one of the very best, in my experience, for the cultivation and fruiting of the Pine Apple; so, too, was that of 1868. We can and have done much by artificial means, but we cannot compete with Nature. The fruits have not only swelled better but the flavon is richer; in some instances the juice was dropping from the fruit before cutting. This took place in June and July. I have cut several Queens of 1 lbs. in weight and one Queen of 6 lbs., and with crowns 2 to 3 inches long. I have not had such a glut as in some seasons. I cut the first fruit in March, and the others have come in two and three a-month ever since. I had two

or three Smooth Cayennes, one of 4 lbs., the other of 5 lbs., but the last-named had a crown 8 inches long. Thirty plants were put into our fruiting Pine stove in August, 1869, being then twelve months old, and, as stated above, the first fruit ripened in March, 1870. I have cut twenty-four Queens and two Smooth Cayennes. Four Queens are now, while I write, November 28th, swelling off. It will, therefore, be observed that the first fruit cut was in nineteen months, and it weighed 4 lbs. The fruit, which weighed 6 lbs., was cut November 5th from a plant two years and three months old, and by far the finest plant in the house; it fruited in a 13-inch pot. I had ten plants in 13-inch pots, and twenty plants in 11-inch pots. Those in 11-inch pots, with the exception of that which bore the 6-lbs. fruit, gave, if anything, larger fruits; though at the time of potting, of course the largest plants were potted in the 13-inch pots. Nothing has been gained in the above instance by large pots.

Will some others give their experience? I shall be very glad to hear what has been the heaviest Old Queen ever ripened. I am aware there are several varieties of Queens; some produce larger fruits than the Old Queen, but none equal it in flavour. I shall also be glad to know the size of crown, as I have seen fruits shown with crowns more than a foot long. This, I consider, ought at all times to be stated when weight is given; then we can form an idea of what the produce is like. To those who have fruit with large crowns let me say—Moderate your top and bottom temperatures, place your plants near the glass, give abundance of light and air; then less crowns will be the result.—C. M. McC.

FITZROYA PATAGONICA.

SINCE the introduction of the above species of Conifer into this country a few years ago I have not heard anything about it. If I remember rightly it was reported as growing in its native country to the height of 70 or 80 feet, and if it is ever likely to attain that height in England, those who planted it on its introduction will by this time be able to form an opinion.

I have planted it in both light and heavy soils, in sheltered and in exposed situations, and the conclusions I have drawn from its appearance have not been favourable to its ever becoming a popular tree in this country; and after four years' trial I could not see any sign of its ever reaching even 10 feet high. The plants remained in perfect health, but they did not increase in height more than 1 inch per year. The side branches, however, made better use of their time, as they grew twice as fast as the leader; but they were so slender as not to be able to support themselves, and the whole plant presented such a shabby appearance and its habit was so straggling as to lead me to conclude it was not worth growing. I may, however, be mistaken, and if any correspondent has succeeded in growing it into anything like a specimen, a few details respecting its treatment will, I feel sure, be acceptable to many others as well as to—THOMAS RECORD, *Hatfield Park*.

A VERMIFUGE NOT OFTEN OBTAINABLE.

THE place in which I lived before the present I had to lock after the farm. A distillery being connected with the place, and there being more wash than the cattle could use, we had it brought to the grazing fields, and emptied over them as liquid manure. Next morning Mr. P.— and I were passing that way, when there were so many worms dead that Mr. P.— exclaimed, "Is it not wonderful how it kills the worms?" Had he been that way a fortnight after he might have said, "Is it not wonderful how it makes the grass grow?"—W. W., *Gardener, Adamstown Glebe*.

GROUND LEVELLING AND PRACTICAL GARDEN PLOTTING.—No. 8.

DRAWING PLANS.

IT is unnecessary to give any more examples of single figures; the foregoing, well understood, will be found sufficient to lead on those whose education has not enabled them to understand the theory and practice of geometrical drawing, and will enable them to design and execute other figures, also to transfer them from paper to the ground. Perseverance alone is required.

The beginner must not be satisfied with his work if it is only "nearly" right; he should try again and again with increased care, and success will soon attend his efforts. It is evident that the foregoing figures would be of comparatively little use without some definite method for their arrangement in groups, &c.

The mode described of transferring a single bed to the ground will not be found sufficient for the transference of a well-designed plan. To transfer intricate designs to the ground it is necessary to find the principal points to work from, and other points of reference, which will be explained practically by aid of the following directions more clearly than by any number of mere descriptive words.

Figs. 29 and 30 are more difficult either to draw on paper or to trace upon the ground than any other of the foregoing examples, but when once the method and practice are clearly understood, difficulties that before appeared as mountains to the uninitiated will soon pass away.

Fig. 31 is the first example composed of a number of beds, and constituting a complete design. From the figures and instructions already given it will be obvious to any person how to draw the design on paper, but how to transfer it to the ground is not so easily understood without some practice. Before beginning to trace a design on the ground, it is necessary to be provided with a line, and two or three pieces of string (whip cord is the best) to use for finding certain points; also some stakes about 10 or 12 inches long, and about 1 inch thick, some pegs 5 or 6 inches long of about the same thickness, and a measuring tape.

To transfer the design to the ground, draw line *A B*, which is 42 feet 6 inches long; describe the square *ABCD* as in fig. 7 (page 344); draw the diameter lines *B R* and *C H*, also the diagonal lines *A C* and *B D*; draw the inside square, allowing 4 feet for the width of the beds; divide the square as in *g g*, leaving 3 feet for an entrance. From centre *o* draw circle *r*, also circles *s* and *t*, as shown by the entire and dotted lines, then draw the four angular beds as shown.

To transfer the design to the ground it is necessary to have the scale at the foot of the plan, or, better still, to have a rule with the scale marked upon it. It is also necessary to have the ground prepared as before described. Insert a stake firmly at point *A*; get a line with a loop at one end, and drop the loop over the stake in point *A*. Stretch the line straight along, say to the length of 50 feet; fix the line there by means of a peg; with the measuring tape from stake *A* measure 42 feet 6 inches on the line to *B*. Insert a stake at point *B*. Lay line *B C* at right angles with line *A B*, which is done in the following manner:—From the stake at point *B* on each side measure any two equal distances, as *f f*; insert a peg at each point; get a string with a loop at one end, drop the loop round one of the pegs, take the other end of the string toward *c*, double the string round a peg, and trace an arc as in *n*. Shift the loop to the other peg, and with the same length of string trace an arc cutting the former one; where the two arcs cut each other is exactly

perpendicular to stake *B*. Lay the line from stake *B* to point *n*, measure 42 feet 6 inches along the line from stake *B*, and insert a stake as at point *c*; get the string and drop the loop round the stake in point *A*, measure 42 feet 6 inches on the string, which is the length of the side. With the radius of 42 feet 6 inches trace an arc as in point *n*; shift the loop to stake *c*, and with the same radius trace another arc, cutting the former one. Where the two arcs cut each other insert a stake as at point *n*, lay the line from stake *c* to stake *n*, and from stake *n* to stake *A*, which is the starting point. Then lay a line from stake *A* to stake *c*, and from stake *B* to stake *D*. These are called diagonal lines; if these two lines are of equal length the square is perfect; if not, it must be made so before proceeding further.

If the lines on the ground do not correspond with the lines on the paper, the plan is of little use; it will only be a guide, and not a working plan, and when traced on the ground it will be found the design is crippled and entirely unsatisfactory.

If the diagonal lines are equal, lay the middle or diameter

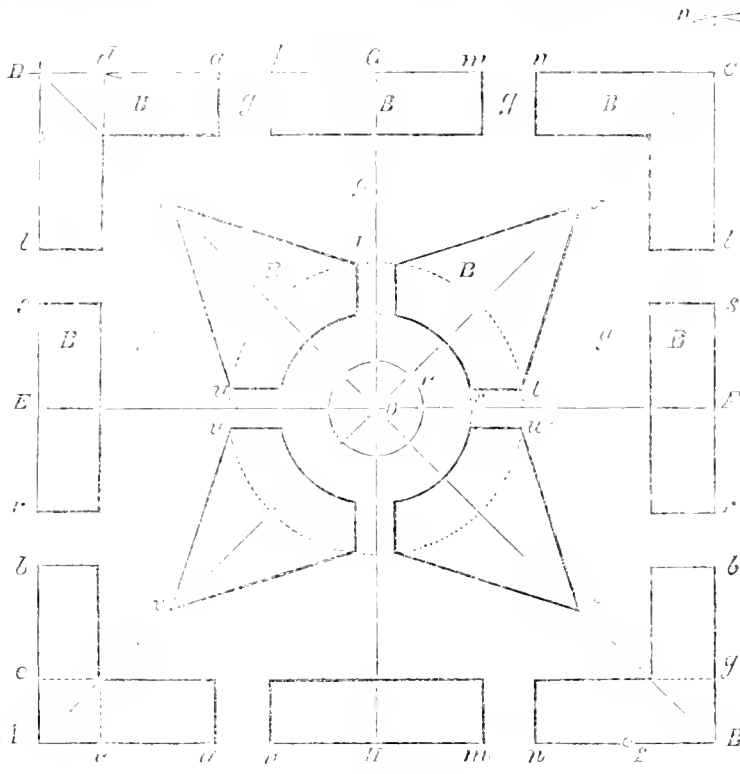

Fig. 31.

lines *B R* and *C H*; where these lines cross each other is the centre *o*. The outside beds are 4 feet wide, according to scale; these are the four corner beds and the four oblong beds. From the stake at point *A* on each side measure 4 feet, and in each point insert a peg as at *e, e*; from each peg measure 4 feet inwards, meeting on the diagonal line; there insert a stake, which is the inner angle of the bed. Find the corresponding points in the same manner. The inside lines can be found by measuring 4 feet on each side of stakes *B C D* in the same manner as from stake *A*. Lay lines, as from *c* to *d*, and from *e* to *g*; where the lines cross each other are the inner angles of

the four corner beds; insert a stake at each point, and lay a line from stake to stake. From stake *A* on the line towards *E* measure 11 feet 6 inches. Insert a peg as at point *a*; from the last peg measure 3 feet on the same line, and insert a peg as at *h*; from peg *h* measure 13 feet 6 inches, and insert a peg as at point *m*; from the peg at point *m* measure 3 feet, and insert a peg as at point *n*; find the corresponding points on line *A* and *B*, also on line *B* and *C*, and on line *C* and *D*, then lay lines between pegs *a a, h h, m m, n n, b b, r r, s s, and t t*. Thus the eight outside beds are lined, and can be cut out. Insert a stake in centre *o*, with a string 9 feet 6 inches long, trace a circle as shown by the dotted circle *t*, insert pegs in the diameter lines *E R* and *G H* where the circle crosses them; on each side of these pegs measure 18 inches, insert a peg at each point as at *u n*. From the stake in centre *o*, with a string 6 feet long, trace circle *s* as shown; reduce the string 3 feet, and trace the inside circle *r*, and insert pegs 6 or 7 inches apart. Then lay lines between the pegs in the outside circle, as from *u* to *t* and from *u* to *v*, and insert pegs about 6 or 7 inches apart in circle *s*, bearing in mind to have a peg at each angle of the bed. Then lay a line round the pegs, also round the pegs in circle *r*. On each side of the stake in centre *o* measure 18 feet 4 inches on the diagonal lines *A C* and *B D*, insert a peg at each point, as in

v r v r, then lay lines as from the peg at point *u* to the peg at point *v*, and from peg *v* to peg *l*, and so on, until the four angular beds are lined; then cut out the beds, and the design fig. 31 is accurately transferred from paper to the ground to a scale of 12 feet to the inch.—M. O'DONNELL, *Gardener to E. Leeming, Esq., Spring Grove, Richmond.*

CHRYSANTHEMUMS.

On the principle that too much cannot be said of a good thing, and the Chrysanthemum affording the chief supply of flowers, both for decoration and for cut blooms, when other flowers are scarce in November and December—even later than that with a few of the Japanese varieties—I now give a list of those which proved here to be good this year, leaving for a future paper a few varieties I saw good at Liverpool.

The proper time for putting in cuttings is November and December, though they may frequently be struck till March; still, I have proved that spring striking does not do for this part of England. Spring-struck cuttings find favour with many, on the ground that they are not so liable to be neglected as those struck in November, but there seems that then there is no time to make them flowering plants.

I say, Strike as early in November as possible, putting in the cuttings round the edges of 3-inch pots, potting them off singly into the same sized pots when rooted, and never allowing them to become pot-bound nor short of water from the time of the first potting till they flower. Water being very beneficial to the tops, either syringe or water overhead in the summer evenings.

I will take the large-flowering varieties alphabetically, beginning with *Amé*: *Fenêre*, which has generally proved good, but is rather loose and off-centred this time with me; *Autonelli* is very good and fine; *Ariadne* is second to none, being very free-blooming, of a pleasing colour, very effective, and late; *Aureum multiflorum*, a very bright good yellow, is very fine and good; *Bacley*, very early and good, pure white. *Bronze Jardin des Hêtales* is one of the best late tall varieties; *Cassandra*, a good early white, but the worst for mildew; *Florence Nightingale*, an excellent free-blooming though small-flowered variety; *General Bainbrigg*, a beautiful large flower and very effective; *Gloria Mundi*, an early, dwarf, free-flowering, good yellow; *Golden Beverley*, the best of the tall early yellow varieties; *Golden Dr. Beck*, a light yellow, very good and bright; *Golden Eagle*, first-rate, red and orange; *Guernsey Nugget*, very prolific and fine, rather late; *Jardin des Plantes*, a well-known tall late, rich yellow variety; *Lady Harding*, a very compact dwarf variety, very good and fine; *Lady Talland*, one of the most telling varieties of its colour; this is really good. *Lady Slade* is a very useful variety. *Little Harry* is, I may say, the finest early golden dwarf flower grown; *Lord Palmerston*, very fine and free, but late; *Mr. Cullingford*, a very fine dark purple variety; *Mr. Gladstone*, a very fine red chestnut, now beautiful; *Mrs. Hallburton*, an extra good flower, almost like a *Pollia*; *Orange Annie Salter*, a decided acquisition in its colour; *Prince Alfred*, a late, tall-growing, good variety; *Pelagia*, a fine flower of dwarf habit, and to be depended on; *Pink Perfection* I have seen good this season, but it is rather shy with me, which I attribute to its being struck late in the spring; *Rev. J. Dix*, a very good late orange red flower; *Robert James*, very striking, superior to *General Bainbrigg*; *White Eve*, the finest white grown. This should be in every collection.

In concluding the list of the large-flowering varieties, I wish it to be distinctly understood that I do not say that those I have named are the only good sorts, or that they are always good, but I believe they may be depended on.

Of the Japanese, which are very grotesque in their appearance, *James Salter* stands first; this is an extraordinarily free variety, and looks more like an artificial than a natural flower. It is an early variety, flowering in November. *Red Dragon* is a good variety; and *The Daimio*, a very effective sort, concludes my list of the Japanese Chrysanthemums.

Of the *Anemone* large-flowered kinds, I only number two—*Fleur de Marie*, a good, large white; and *Gluck*, a very fine golden orange.

Next come the *Pompon* *Anemone*-flowered. *Cedo Nulli* is the first, it being a very early useful variety; in fact, I may say the same of the other varieties of *Cedo Nulli*, *Golden Lilac*, which are very desirable for cutting. There are, doubtless, many desirable varieties of both the large and small-

flowered *Anemone* *Chrysanthemums* worth growing, but I content myself with the few named above.

Of the *Pompoms*, *Bijou de l'Horticulture* is very good and useful; *Bob*, well known, as it comes out better than ever; the same of *Drin Diun*. *Général Canrobert* is early and good; *Lizzie Holmes*, a very beautiful variety; *Lucinda*, very fine; *Rosa Travenna* is very early, and so is *White Travenna*.

The above list, I am aware, contains the names of many old varieties, but they are none the less desirable on that account. When speaking of the row sorts, I think the first year should not be finally decisive on their merits or demerits, as I have seen flowers condemned one year, and the following season they could not be too highly spoken of. My object in writing these notes is to place in the hands of the amateur or working gardener a short list of really good varieties suitable for conservatory and greenhouse decoration.

The culture of the *Chrysanthemum* being so generally known, it is not necessary to say more than that, to have good healthy plants, strike the cuttings in November or December in a cool house; one the same as that in which the plants are to grow. Pot the cuttings as soon as rooted, and repot them when the roots touch the sides; give them their final shift in August. Supply abundance of water both at the roots and top, but keep all manure water from them till they have set their flower buds. I do not plunge the pots, considering the plants healthier if not plunged, though requiring when unplunged more attention in the watering and repotting.—STEPHEN CASTLE, *Bent Hill Gardens, Frestwich, Manchester.*

THE POTATO AND ITS CULTURE.—No. 3.

FIELD CULTURE.

After the crop has been cleared off the ground allotted for Potato planting in the spring, it should be well cleaned previous to manuring, advantage being taken of a fine day or two, and the manure drawn on and spread over the surface; it should be next ploughed up as deeply as possible, and then left till planting time, when it will have to be cross-ploughed, that the rows may range north and south, so that the sun can most effectually fall upon them.

As soon as the preceding crop is off the ground, if this is poor and weedy, surface-dress it with a heavy scuffle, and heavy harrows to follow it, and let the weeds be picked off and burnt; and if one good scuffling do not clean the ground thoroughly, go over it again previous to manuring it. A fine, dry day or two should be chosen, and the dung drawn on and spread over the surface; and let the ground be ploughed up as deeply and as roughly as possible, reversing the furrows each time. The more roughly it is ploughed the better, for the frost can get into and through it better than if ploughed more evenly, and thereby kill vermin and pulverise the soil, and it will be far easier to turn over in the spring at planting time.

The reason I recommend manuring early in winter is that the manure should be better decomposed, and to further this object good mellow dung should be used.

The best way to plant the Potato in the field is to plough in the sets. Send the plough up the field, making a furrow about 1 inch deep. In this furrow the sets should be placed about 9 inches apart. A sufficient number of hands should be employed in planting, so that the plough may not be hindered. To obtain the proper distance from row to row the second furrow should not be planted, but it requires ploughing, or else the planted one will not be covered in. The rows will be a good distance asunder, so that the operations of earthing and digging or raising the crop will not interfere with the rows in the least. The Potato-earther in field culture is an instrument very much resembling a plough, the chief difference being that it is double-breasted, and the breasts are made of wood. I have seen wooden breasts made to fit to the plough. It will be seen that by the earther going one bout (as the ploughmen term it), or once up the field and down again, the plough cuts or leads up four rows.

The raising implement has a beam similar to a plough; in fact, the breast can be taken off the plough to admit the raiser, so that it saves the expense of a beam, &c. This raiser is sent up the centre of the rows, the horses walking in the furrow on each side of the row which is being raised; and it not only raises—that is, digs them up very much quicker, but very much better, for I have seen Potatoes come up amongst the succeeding crops, although they had been dug with the fork with the utmost care; but it is plainly seen that when the root is being

lifted with the fork the soil trickles back into the hole, and the fork has to be thrust in twice, and sometimes thrice, and then tubers are left behind; but the raiser goes to the bottom of the row and lifts every one to the surface. The ground must be flat-hoed once or twice, according as its weediness requires, previously to earthing. When the hantun is of sufficient height and strength the earther should be introduced, and when this task is accomplished nothing more is necessary to be done to the plants, except in cases where they have to be earthed-up a second time, but this is very rare.—J. C. LEWIS, *Gardener and Bailiff, Sulbury Rectory, Derby.*

MY AURICULAS IN 1870.

ALTHOUGH it was an unfavourable season for exhibiting in the neighbourhood of the metropolis, but few flowers being in bloom in the middle of April when the spring exhibitions of the Royal Horticultural and Botanic Societies were held, and on the 20th of May at the Crystal Palace nearly all were over, yet some of us about the beginning of May had an excellent bloom; and as all lovers of the flower are ever glad to get news concerning it, a few notes on my own blooms may not be unacceptable. It is one of the comforts—although, perhaps, also a disadvantage—connected with this flower, that we cannot give lists of the “new flowers of the last season,” not one-fifth of which will survive a couple of years. The flowers of days long ago are the favourites now, and we may only seem to be repeating an oft-told tale.

GREEN-EDGED VARIETIES.

Ashton's Prince of Wales.—Not by any means a large flower. The green of the edge pure; truss somewhat short.

Campbell's Admiral Napier.—A neat flower of good proportions.

Dickson's Duke of Wellington.—A flower much appreciated in the neighbourhood of London, but with too much colour in it to suit the particular taste of a connoisseur. In Ireland, where the taste is, I think, purer, it is not much thought of, neither is it in Lancashire.

Dickson's Earl of Errol.—A small grower. The edge very green, and the colour brilliant.

Leigh's Colonel Taylor.—I had one excellent bloom of this, perhaps the most noted of all Auriculas, from the high price it used to hold. The edge is a beautiful grass green, the paste is thin, and the plant is not a strong grower.

Hudson's Apollo.—A very refined flower. The ground colour is almost a chestnut, and the edge a light and pure green.

Littin's Imperator.—Flower-stems too tall. The plant is small, and the flower somewhat pointed; still it is good and useful.

Oliver's Lovely Anne.—Another very favourite flower in the neighbourhood of London, but it is very uncertain; sometimes, indeed more frequently, it is a grey edge—since were so this year.

Dickson's Matilda.—Another of Dickson's beautifully coloured flowers. It has a good constitution, but is rather short in the stalk at times. It makes a good exhibition plant, and very often can be shown as a grey edge.

Traill's General Neill.—A very pretty and neat flower, at times giving a capital truss, and a good exhibition plant.

Traill's Mayflower.—Another neat and good flower, and of fair constitution.

GREY EDGES.

Barlow's Morning Star.—A clean and good flower, and at times, as it did with me this year, forming a good truss.

Chapman's Maria.—I had a truss of this the present year, which in some points was unapproachable. The ground colour is one which is met with in no other Auricula, nor, as far as I remember, in any flower—a beautiful violet black; but the eye is too pale, the edge too dubious, and the petals too pointed, to rank it as a first-class flower, although for its colour it must be grown.

Chapman's Sophia.—A flower of the same style, but not so good; still, brilliant in colour and very pretty.

Clark's Mary.—A good flower, neat, and even in shape, and it ought to be in every collection.

Cheetham's Lancashire Hero.—A very beautifully shaped flower, apparently a seedling from General Bolivar. At one time it might have held the premier place in grey edges, but it is now surpassed, I think, by

Headly's George Lightbody.—A splendid flower, associated with the names of two of our very best florists. It is beauti-

fully shaped; a clear and distinct grey; ground colour dark; eye orange, and apparently a good-constitutional plant. Altogether perhaps the best Auricula in growth.

Fletcher's Mary Ann.—A good flower, with, however, the defect of having too small an eye. A small-habited plant, but not an unhealthy one.

Fletcher's No Plus Ultra.—A very large flower, probably the largest of any Auricula grown, but the constitution of the plant does not seem equally vigorous; still, it is not a bad grower, and it is always a desirable flower owing to its great size.

Lightbody's Richard Healdly.—A very pleasing flower, of good habit and refined in character. It generally blooms late—too late for the early shows held in April.

McLean's Unique.—A very fine flower when caught at its best, but the colour is apt to become soxy after it has been a little time in bloom.

Syde's Complete.—A very beautiful flower and very constant. It shows a very large truss, and hence it is necessary to thin the pipe in time, otherwise they are too small.

Waterhouse's Conqueror of Europe.—One of the most useful flowers we have. Very constant, pipe large, edge very decided grey, and habit of plant excellent.

WHITE EDGES.

This is the most defective of the four classes of Auriculas, there being few really good flowers in it, and, unfortunately, the very best of all is gradually becoming more and more difficult to obtain.

Heap's Smiling Beauty.—A very fine flower, but uncertain; in some seasons very fine, and in others indifferent. Its chief fault is that at times the white of the edge has a greyish colour;

Hepworth's True Briton.—A very fine flower. The pipe is perfect in shape, but it is difficult to get it flat. The plum ground colour contrasts well with the edge. The foliage is green and heavy.

Lightbody's Countess of Dumore.—A fairish flower, but not possessed of first-rate qualities.

Taylor's Glory.—The best of all white-edged flowers. What trusses I remember of it with my friend Dr. Plant! but now, alas! it seems to be dying out—so much so, that I find Mr. Lightbody has eliminated it from his list, and Mr. Meiklejohn has but small plants of it. It is a pure white edge, and has a well-shaped and smooth pip.

Traill's White Rival.—A good flower, but not equal to some of those already named.

Smith's No Plus Ultra.—Another very good flower, and of good constitution.

Popplewell's Conqueror.—Not strictly speaking a first-class flower, but always sure, throwing a good truss, and having very handsome deeply serrated foliage.

SELFS.

A very favourite class with outsiders, who will always pick out the rich-coloured flowers with which it abounds in preference to the edged varieties; although in the eyes of a fancier they do not hold so conspicuous a place, still they are very beautiful, and help greatly to relieve a stage.

Spalding's Blackbird.—Nearly black. Good round petal, and a good trusser.

Netherwood's Othello.—A first-class flower. Long stem, deep colour, and always good.

Campbell's Pizarro.—A deep, rich maroon, fine flower. The colour very rich, and the foliage quite white.

Smith's Formosa.—Small flower, of a most peculiar shade of light blue. Very effective for contrast with the deeper-coloured flowers.

Smith's Mrs. Smith.—A very constant deep-coloured flower, rarely disappointing, and of good habit. Indeed, the selfs are much more vigorous, as a rule, than the edged flowers.—D., Deal.

FLORAL CRITICISM.

[THE following is the paper to which was awarded Lieut.-Col. Scott's prize of £5 5s., for the best essay on the Principles of Floral Criticism, May 4th, 1870. Two other papers were sent in.]

THIS is a subject at once broad and comprehensive, affording scope for much more copious discussion than can be given in an essay as concise as this must of necessity be; for to enter into every detail of the subject—especially with regard to the standards of perfection set up for the different members of the floral world—would necessitate the writing of a good-sized volume. It is incumbent upon a writer of an essay of this description to be brief and to the point, and this I have studied to be; and in so doing I have endeavoured to discuss the matter from a natural and not artificial point of view, commencing

with the newly-introduced individual, and passing thence to the training thereof.

Newly-introduced plants should possess in some degree the following properties, which form the points upon which they should be judged:—1, Novelty in bloom or foliage; 2, Hardiness; 3, Vigour; 4, Blooming Capabilities.

1. *Novelty*.—Diversity in shape or colour of foliage is as essential to the production of effect as diversity in colour or form of bloom, or in habit or mode of growth. Novelty in either respect should, therefore, be considered as forming a very essential point.

2. *Hardiness*, or adaptability to the climate of this country with as little protection as possible, is undoubtedly of the greatest importance to horticulturists generally, in consequence of the great expense attached to the cultivation of plants which do not bear up against our changeable climate and low temperature. The chief aim of collectors and introducers of plants should be to intraduce such things as will involve the smallest possible amount of expense in their cultivation.

3. *Vigour*.—Hardiness and vigour of constitution are essential properties, for while we want hardiness we also require quick or vigorous growth and maturation, in consequence of the short and uncertain season wherein plants have to perform these operations.

4. *Blooming Capabilities*.—In addition to profusion we want duration and persistency, and more especially do we require persistency in conjunction with profusion. For if the plant be ever so profuse a bloomer, and the bloom drop as soon as it expands, it is comparatively worthless for decorative purposes.

Having considered the essential points from which a plant should be judged, I now pass to the consideration of the principles upon which the flower should be criticised. It is of the first importance that regard should be had to the chief characteristics of the order, class, or genus to which the individual may belong, and especially is this of importance with respect to double flowers; for to expect duplication to be as complete in a representative of the Geraniaceæ as in Rosaceæ or Composite, is unreasonable, in consequence of the difference existing between the number of stamens in the two first-named, and the composite nature of the latter. Neither can we expect it to be as complete or full in a flower whose aestivation is valvate, as in one in which the aestivation is imbricate. The forms assumed by flowers should also be considered in accordance with these general characteristics, whether they be regular or irregular.

The colour of the flower should in all cases be distinct from any previously known variety, except where it has other qualities of superior merit to commend it to notice, the resemblance of colour in many varieties of the same species being so considerable as to cause the greatest confusion. With colour, the stability of the same is essentially necessary, as is also good substance in the component parts; and more especially is this of importance in florists' flowers, for what presents a worse appearance with regard to flowers than a washy and flimsy flower? As in plants, so with their bloom; we want such flowers as will stand, without losing their colour, a good drenching rain or syringing—to one of which they will undoubtedly be in most cases made subject, especially the former, if the plants be hardy enough to be placed out of doors.

Odour is a property or qualification to be possessed in order to come near to perfection. Such odour to commend itself should be delicate and fragrant, for where the odour is strong, if placed in a confined atmosphere it becomes overpowering, and consequently obnoxious; strong-scented flowers are consequently comparatively worthless for use in the decoration of the sitting-room, where the air is undoubtedly confined.

To set up a standard by which flowers should be judged universally would be impossible, each species having a standard peculiar to itself. The point should be to ascertain what would make a plant or flower perfect, although there may be no chance of ever reaching such perfection; and then the comparative merits of all plants might be judged by the degree in which they approached the imaginary standard of perfection.

Having thus considered the principles to be observed in the criticism of newly introduced plants, I pass to the most important of all, with respect to a plant to be grown as a specimen of good cultivation—viz., its training.

The effect produced by plants, either individually or collectively, is regulated by the form they assume, or are made to assume. It is evident, therefore, that such forms only should be adopted as will produce good effects without in any way impairing the health, and consequently the beauty, of the individual. The modes of training of the present day are undoubtedly too conventional. Not only, in very many instances, is natural beauty sacrificed, but shapes and forms are adopted in which the greatest possible amount of distortion is necessary to obtain a given result, and detrimental alike to health and beauty, and very often diametrically opposed to natural disposition. Such modes of training should be discountenanced by censors, and only those admitted or encouraged that are most in harmony with natural disposition. Only just as much of the conventional should be admitted or allowed as may assist Nature in producing symmetry of form. The forms thus produced would not only be in harmony with Nature, but would produce an effect altogether ornamental, which would be much in advance of the tight-lacing system, of which we see so much.

There is no doubt that the loss of foliage from which so many

trained specimens suffer before their blooming season arrives, is attributable, in a great measure, to tight lacing, as is so often the case with Azaleas. The pyramid, or some modification of that form, is no doubt the form best suited to those plants, as well as to the majority of flowering plants, being more in accordance with natural disposition; but to tie in every twig so as to prevent the appearance of its having been cast in a mould, or glued to a shape made for the purpose, is not only unnatural, but injurious. Plants thus grown or exhibited are far from the standard of perfection set up by Nature. A plant denuded of the greater portion of its foliage, if ever so well bloomed, cannot justly be adjudged an example of perfection; and a plant tied so as to hide the foliage in endeavouring to expose the greatest possible amount of bloom to the eye at a glance, is an example of bad taste, and a direct violation of the principles daily exemplified in nature. To give prominence to bloom is unquestionably correct, but not to the exclusion of foliage. Foliage is as essential as bloom to the production of effect. There are exceptions, where plants naturally produce bloom in advance of foliage. In such cases bad training or cultivation is not the cause, but natural disposition. Plants, to show their beauty either individually or collectively, should not be made to assume anything like stiffness or formality. To produce in plants for exhibition the greatest possible amount of bloom and foliage in the smallest possible space as regards pot room, should be held as most essential, thereby shutting out from our exhibitions large and cumbersome pots.

The whole matter seems to resolve itself into the principle of setting up an ideal standard of perfection, consonant with the habits and general characteristics of different species, and deciding the merits of the plants by the degree in which they approach it.—A. BRADLEY, S. Salisbury Road, Highbury Hill, late of Stowlangtyn Hall, Bury St. Edmund's.

ROYAL HORTICULTURAL SOCIETY.

DECEMBER 7.

FRUIT COMMITTEE.—G. F. Wilson, Esq., F.R.S., in the chair. Mr. Thomas Simpson, of Froonfield, Chelmsford, sent a Cauliflower, called "New Autumn Cauliflower," which, in the opinion of the Committee, was the same as Walsheeren. Mr. T. Bray, gardener to E. A. Sanford, Esq., Nynohed, Wellington, sent a bundle of forced Asparagus of great merit, which received a special certificate. Mr. Calder, Luton Hoe, Beds, sent a seedling Cucumber, raised from seen Berkshire Challenge and Lord Kenyon's Favourite, but it was not regarded as a desirable acquisition. Messrs. Rutley & Silverlock sent specimens of Banbury Improved White Spanish Onion, grown by Mr. P. J. Perry, Banbury, which received a special certificate as superior specimens of the true White Spanish Onion. Mr. M. Hibblethwaite, gardener Aukland Hall, sent fine specimens of the true Lapstone Kidney Potato.

Rev. T. C. Brabant, of Guernsey, sent cobs of thirty-four distinct varieties of Indian Corn, grown in Guernsey. Some of these were of the ordinary yellow colour, others red, white, brown, and mottled, and all were as perfectly ripened as imported Indian Corn.

Mr. R. T. Pince, of Exeter, sent a bunch of a seedling Grape, raised from a seed taken from the same berry as that from which Mrs. Pince's Black Muscat was obtained. The bunch was of large size and tapering, exactly similar in shape to that of the Black Muscat. The Committee did not think the quality sufficiently good to merit a first-class certificate.

Mr. William Paul, of Waltham Cross, sent three seedling Grapes. One, called Waltham Cross, was very large, the berry being one of the largest of the whites in cultivation. The bunch is large and long, the berries long-oval, and of an amber colour, fully 1½ inch long, and 1 inch wide, like a good-sized Plum, and the flesh firm and solid, with an excellent flavour. It received a first-class certificate, and was considered a valuable late-hanging and good show variety. Mr. T. Clements, gardener to G. G. Hall, Esq., Blackwell Hall, Chesham, sent three good bunches of Black Alicante Grapes, which were rather deficient in colour. Mr. Wells, of Southend, sent five fine and remarkably well-coloured bunches of Black Alicante, grown in his ground vineries. They were well grown, but deficient in flavour. Mr. Sage, of Asbridge, sent a bunch each of Black Alicante, Lady Downe's, and Mrs. Pince, all of which were very well grown, and excellent in flavour. They were awarded a special certificate. Mr. Ellis, gardener to R. Lewis, Esq., Greenford Hall, Southall, sent Barbarossa, very deficient in colour.

Mr. McLean, gardener to W. P. Herrick, Esq., Beau Manor Park, Loughborough, sent a fine and handsome specimen of Smooth-leaved Cayenne Pine Apple, which received a first-class certificate. Messrs. Standish, of Ascot, sent a seedling Apple, called Painted Lady, a beautifully coloured variety, being rich bright crimson streaked with yellow. It is highly ornamental, and, the flavour being acid, it was commended for its beauty.

Mr. Gilbert, of Bangleby Gardens, sent a seedling Apple, called Mea's Seedling, which was past its best. Mr. Turner, of Slough, sent a basket of Cornish Aromatic Apple, fine in colour, and excellent in flavour. It was awarded a special certificate. Mr. Cox, of Redleaf,

* Mr. Bradley obtained a first class certificate in Floriculture, and a second class certificate in Fruit and Vegetable Culture, at the Royal Horticultural Society's examination in December, 1870.

sent a dish of highly-coloured Blenheim Pippins, which were much admired.

Mr. Chaff, gardener to Alfred Smee, Esq., F.R.S., sent a collection of twelve varieties of Kitchen Apples and twelve of dessert, to each of which a special certificate was awarded. Mr. Hibbelthwaite, of Acklum Hall Gardens, sent a collection of Apples and Pears, to which a special certificate was awarded. Mr. J. Hepper, gardener to C. P. Millard, Esq., The Elms, Acton, sent a quantity of fine specimens of Chamoisette Pears, which received a special certificate. Mr. Turner, of Slough, sent a seedling Pear, called International. G. F. Wilson, Esq., sent a basket of Josephine de Malines Pears of extraordinary size and beauty, to which a special certificate was awarded. Mr. Gilbert, of Burghley Gardens, sent a stand on which to exhibit fine Apples, which was approved by the Committee.

Messrs. Carter & Co., of Holborn, exhibited specimens of the New Red-skinned Flour Ball, and the Red American Potatoes, for the purpose of deciding whether they are synonymous; but the Committee declined to decide till they were seen growing. Mr. William Thomson, Blantyre, sent two seedling Potatoes, Hero and Favourite. Both were boiled, and Hero was found to be very mealy and of good flavour.

Messrs. Carter & Co. sent very large specimens of White Belgian, Altrisham, and Long Red Carrot, which received a special certificate.

Prizes were offered on this occasion for the best collection of Salads, and were taken by Mr. Hepper, gardener to C. P. Millard, Esq., The Elms, Acton, and Mr. Gilbert, gardener to the Marquis of Exeter, Burghley Park. Mr. Hepper had Mustard, Curled Cress, Australian Cress, Corn Salad, Red Turnip Radish, Water Cress, two kinds of Cucumbers, Cos and Cabbage Lettices, White and Green Curled and Batavian Endive, Red and White Celery, Beet, and Onions. Mr. Gilbert, who was second, had Mustard and Cress, Cucumbers, Celery, Lettuce, Batavian and Curled Endive, Beet, &c. Both collections were neatly set up—that of Mr. Gilbert in a box made for the purpose of exhibiting Salads.

Mr. Lee, of Windlesham, sent a fine super of honey, weighing 35 lbs., and one of his new octagon straw hives.

This was the last meeting of the year, and the Committee was therefore dissolved, in accordance with the resolution of last year, and a vote of thanks to the Chairman was passed unanimously.

FLORAL COMMITTEE.—W. Beattie Booth, Esq., in the chair. From Mr. Williams, Holloway, came a collection of Orchids, in which were good specimens of *Lelia anceps* with six spikes, *Calanthe Veitchii*, *Odontoglossum cariniferum* and *Rosii*, *Cattleya Skaueri*, and *Maxillaria nigrescens*. Mr. Williams likewise sent a collection of his fine ornamental-fruited Solanums. A special certificate was given for the two collections.

Mr. Robins, gardener to Sir E. Kerrison, Bart., Oakley Park, Basingstake, exhibited a plant of *Capsicum Yellow Gem* trained as a dwarf standard, with a rather flat head, and bearing numerous yellow pods, giving the plant a very ornamental appearance for decorative purposes. For this a special certificate was awarded.

Messrs. Veitch sent *Amaryllis Spotted Gem*, a hybrid between *paradinum* and another sort, with the white ground beautifully dotted with red.

From Dr. Ainsworth, Lower Broughton, Manchester, came a very fine spike of what was called *Oncidium Barkeri*, and which was the *O. tigrinum* of La Llave. For this a special certificate was given; and a similar award was made to Messrs. J. Brooke & Co., Fairfield Nursery, Manchester, for *Dendrobium bigibbum* with a spike of eleven flowers, six of which were in great beauty, the rest not being as yet expanded, and for a very large-flowered *Odontoglossum Rosii* with two fine blooms.

Mr. Trusler, Farnham, Surrey, sent seedling Carnation Sensation with variegated leaves, and Mr. Drover, Farnham, a seedling Zonal Pelargonium, and *Selaginella leptophylla*, the Resurrection Plant.

Mr. Green, gardener to W. Wilson Saunders, Esq., Hillfield, Reigate, had a first-class certificate for a *Mormodes* with three spikes resembling those of a Hyacinth; the flowers red with deeper-coloured spots, the column white, but in a younger state they are of a rich orange. There is some doubt as to the species—it bears considerable resemblance to *Mormodes Cartoni*, figured in the "Botanical Magazine," t. 1211, but differs from it in colour.

Mr. W. Lee, Arundel, Sussex, had a first-class certificate for seedling Carnation White Nan, and a second-class certificate for Maiden's Blush, both free-blooming varieties. Mr. G. Goddard, gardener to H. Little, Esq., Cambridge Park, Twickenham, sent a collection of Fern-leaved Primulas; and from Mr. Wiggins, gardener to W. Beck, Esq., Isleworth, came a fine collection of the same, including fine white and crimson varieties, for which a special certificate was given. Mr. Wiggins also sent some varieties in which the flowers were streaked and dotted, and in one instance half white, half purple. Mr. Brown, florist, Hendon, had a special certificate for collections of seedling *Cinerarias* and Chinese *Primulas*, both very bright in colour.

Messrs. Perkins & Sons, Coventry, had a first-class certificate for a seedling *Selaginella* called *albo-lineata*, tipped and lined with yellow, a very ornamental variety.

From Messrs. E. G. Henderson, St. John's Wood, came a collection of 30 Sedums, 113 species and varieties of Saxifrages, 70 Sempervivums, and several *Echeverias*, Aloes, and similar plants. A special certificate was awarded, and a like award was made to the same firm for a very attractive group of winter-flowering tree Carnations.

Mr. Stevens, Ealing, exhibited a basket of Ealing Rival Tricolor Pelargonium, which has been frequently noticed, with finely-coloured leaves. Mr. Goddard, gardener to H. Little, Esq., Cambridge Park, Twickenham, had a first-class certificate for *Cyclamen persicum purpureum*, a beautiful purple-coloured variety. A special certificate was given to Mr. Clarke, Twickenham, for a fine collection of *Cyclamens* raised from seed sown on January 22nd of the present year.

Prizes were offered for twenty-four cut blooms of Japanese and late *Chrysanthemums*. The first prize was taken by Mr. Douglas, gardener to F. Whitbourn, Esq., Loxford Hall, Ilford, with a stand in which were fine examples of *Miss Marechaux*, *Princess of Teck*, *Yolande*, *Plutus*, *Blonde Beauty*, *Virgin Queen*, *Lady Talford*; and of Japanese varieties, *Comet*, *Dr. Masters*, and *The Mikado*. There were also very good blooms of several others of the large-flowering varieties. Mr. Goddard had the second prize for a stand of twenty-four—viz., twelve Japanese kinds, of which *The Sultan*, *The Daimio*, *Madame Godillot*, *Dr. Masters*, and *Aurantium* were the most conspicuous, and twelve large-flowering kinds.

Class 2, was for the best collection of hardy evergreens bearing berries; in this class there was no entry, but Messrs. Standish & Co., of Ascot, sent a beautiful collection of green-leaved and variegated Hollies, consisting of *Hex balcarica hybrida*, and *I. Handsworthii pendula*, the yellow-berried Holly, a number of *Aucubas* in berry, *Skimmia oblata*, and the black-purple-berried *Raphiolepis ovata*. This collection, containing so many plants bearing a profusion of scarlet berries, had a fine effect. A special certificate was awarded.

Class 3 was for the best collection of herbaceous plants suitable for out-door winter decoration. The first prize went to Messrs. E. G. Henderson, who were the only exhibitors, for a collection in which were *Statice Armeria*, *Centaurea rousina*, *Festuca glauca*, *Achyrocline Saundersii*, *Statice pseudo-Arueria*, var. *dianthoides*, *Thymus strictus*, *Cimeraria acanthifolia*, *Veronica Andersoni variegata*, *Centaurea asplenifolia*, variegated *Thymes*, *Stachys lanata*, *Arenaria balcarica*, *Ajuga genevensis rubra*, *Ambly alpina variegata*, *Veronica candida*, *Aceua microphylla*, *Lilium candidum aureo-variegatum*, *Hebebra rubra*, and some others.

A prize of £5 was offered by J. Bateman, Esq., for the best collection of cut blooms of *Cattleyas*, the flowers to become the property of the Society, but no exhibitor came forward.

GENERAL MEETING.—W. Marshall, Esq., in the chair. After the preliminary business and the election of eleven new Fellows, the Rev. M. J. Berkeley remarked with regard to the *Mormodes* exhibited by Mr. Green, gardener to W. Wilson Saunders, Esq., that he believed Mr. Green very properly considered it to be a variety of *Mormodes Cartoni*. At one time he (Mr. Berkeley) had a notion that it belonged to *M. igneum*, figured in the third volume of "Paxton's Flower Garden;" but in the same plate as *igneum* were two sorts, marked B and C, which Dr. Lindley considered to be mere varieties of *M. Cartoni*, and Mr. Berkeley had no doubt that Mr. Green's *Mormodes* was identical with that distinguished as B. A Grape, of which the bunches were parti-coloured, next came under notice, and it was remarked that the same peculiarity extended to the leaves.

Mr. Meacham's remarks on fasciation were then referred to, and Mr. Berkeley said there had been some confusion between fasciation and polyclady, in which, from the attacks of Fungi and other causes, an extraordinary number of branches are produced. Mr. Berkeley, after reading a paper from the Rev. T. C. Brabant on the varieties of Maize exhibited, remarked that the experience at Chiswick had not been favourable to the cultivation of Maize as a vegetable.

The Chairman announced that as there had been no exhibition for Mr. Bateman's *Cattleya* prize, that gentleman had decided to again offer the same amount, but divided into a prize of £3, and one of £2, at the next meeting, January 15th. It was also stated that the Rev. G. Kemp had again offered his prize for out-door Grapes for next year, but to be competed for in November instead of October, as it was this year.

NOTES AND GLEANINGS.

It is gratifying to know that there is now an establishment for the EXPORT OF JAPANESE PLANTS, SEEDS, AND BULBS. The head of the establishment is Mr. C. Kramer, Yokohama, Japan.

As an instance of the RAPIDITY WITH WHICH INTRODUCED PLANTS SPREAD, when soil and climate are congenial to their habits, we may point to the *Euphorbia prostrata*, *Lit.*, a little annual weed in Jamaica and Trinidad, which became introduced by chance about ten years since into a garden in Madeira, situated some 400 feet above the sea; from this spot it has rapidly spread down the steep road to the town; while up the other hills, separated by deep ravines from that down which it came, it has scarcely crawled at all, a downward course apparently being far easier for it than an upward one. It has, however, slowly crept up another hill at the rate of about 10 feet a-year. The seeds, which are described as eamunculate, with sharply tetragonal paleæ, transversely keeled, are well adapted for sticking to the clothes of travellers, and to be

carried about, so that we might well expect the plant to crop up in all directions. Mr. Lowe says that it is now to be found everywhere in Funchal below 500 feet.—(Nature.)

CHATSWORTH.—No. 2.

The kitchen garden is across the park, and at a considerable distance from Chatsworth House; it is very extensive. In addition to the fine crops of vegetables on all sides, the ranges of glass houses and their contents are a most interesting and instructive sight. Many of them rest against the cross walls which intersect the garden at regular distances; but there are other ranges and separate houses near the entrance to the gardens first claiming notice. The first in order of these is the Amherstia house, containing the large plant of *Amherstia nobilis*. The plant, I was told, had produced this season nearly a hundred of its gorgeous racemes; it certainly ought to present an appearance of uncommon magnificence when in flower to compensate for its very dull aspect at other times. A variety of Pitcher Plants growing in this house were very fine, especially *Nepenthes Hookeriana* and *Rafflesiana*. Here was also a striking group of the large-leaved *Theophrasta imperialis*.

In pleasing contrast to the dullness of this house, the Victoria house strikes one as a peculiarly light and attractive structure; its contents were all objects of interest, and every plant was in fine health. Of course, the regal Lily in the central tank is the first object for which one looks; the foliage was good, but there were no very extraordinary flowers visible at the time of my visit, September 1st. Some fine specimen *Achimenes*, intermixed with Ferns and dwarf Palms, formed a graceful and attractive margin to the Lily tank. The rippling cadence of the water falling on the little revolving wheels, which are ingeniously made to constantly agitate the water in the tanks, has a novel and pleasing effect. Growing in the corner tanks and around the sides were fine plants of the huge-leaved *Caladium esculentum*, *Nymphaea dentata*; *Nymphaea stellata*, with blue and yellow flowers; *Nymphaea Devoniana*, with deep pink flowers; the singular pendent Rush-like *Bonapartea juncea*; the beautiful *Pandanus utilis*; *Clerodendron coccineum*, a perfect mass of bright scarlet flowers; and *Nelumbium speciosum*, with deep green peltate foliage borne on long slender stalks. The building is 68 feet long by 48 feet wide; it has a ridge-and-farrow roof, supported by light iron pillars, which are painted blue and white.

The New Holland house is about 100 feet long by 30 wide. Some *Fuchsias* trained to the roof, and laden with flowers, had a pretty effect. The body of this house was filled with magnificent specimen hardwooded plants; some Heath, pictures of health, must have been quite 5 feet in diameter; the *Azaleas* and *Camellias* were also very fine.

A drive leads past this house to Lady Paxton's villa; it was covered with the white spar for which Derbyshire is so famous. From its chaste appearance this material is admirably adapted for walks in many parts of ornamental grounds; in the flower garden some caution must be exercised in its use, but among the greenery of shrubs it is very effective. A winding flower border on one side of the drive struck me as contrasting very favourably with the formality of the ordinary straight ribbon border. All the borders were planted with much taste; one of eight rows was particularly fine; the front row was *Cerastium tomentosum*, the second *Lobelia speciosa*, the third *Golden Purothrum*, the fourth *Iresine Herbstii*, the fifth a variegated *Veronica*, the sixth a brown *Calceolaria*, the seventh *Stella Pelargonium*, and the eighth *Cineraria maritima*.

A span-roofed stove contained a fine collection of plants, such as *Clerodendrons*, *Dracenas*, *Caladiums*, a fine *Allamanda nobilis*, the pretty *Meyenia creta*, *Bougainvillea glabra* laden with its pretty pink bracts, and the beautiful *Echites rabecvosa* climbing under the roof. Next this were two very light houses of a similar form, used principally for forcing Vines in pots. Some Cucumber plants were being started in one house for a winter supply, and in the other were Kidney Beans in pots, the young plants being just visible above the soil. These useful houses are also employed for forcing Strawberries and a variety of other purposes.

Of the other miscellaneous houses, an old stove contained some fine plants of *Pandanus elegantissimus* and *Javanicus variegatus*, and in a greenhouse were some immense pyramidal *Azaleas* 8 feet high, and a very fine stock of healthy young plants of large-flowered *Pelargoniums* trained to the usual flat surface, also a fine batch of *Primulas*.

Turning now to the vineries, the Vines in the early house

were already pruned and in readiness for work. In the next house were the Vines from which were cut the Grapes that were exhibited at Oxford. The young wood of these Vines was not particularly large, but it was thoroughly firm and well-ripened, with plenty of fine plump buds; the foliage was large and very healthy. There were plenty of bunches still hanging to show how fine the crop must have been. The varieties were Black Hamburg, Black Prince, and Mill Hill Hamburg; the last-named kind had magnificent well-shouldered bunches of very large deep black berries, which had that hammered appearance usually developed in well-grown Grapes of this class.

In the first of the lean-to ranges, which I was told were about 200 feet long, the first and second houses were both wholly occupied with Black Hamburg Vines, all carrying a splendid crop of high-coloured fruit. The third division was a mixed house of Black Prince, Charlesworth Tokay [*Muscat of Alexandria*], small in bunch but fine in berry, and Frankenthal with magnificent bunches splendidly coloured. In the fourth house were more fine bunches of Frankenthal, Royal Vineyard with tolerably large bunches and with very vigorous wood, some very fine Black Tripoli, and some excellent examples of the delicious Black Frontignan. Frankenthal appears to be a favourite here, for in the fifth house it was in full force with immense bunches splendidly finished. Black Alicante also had a grand crop of fruit, and Lady Downe's was equally fine; its wood of the current year was very stout and vigorous. The sight of these fine houses of Grapes was a treat, the condition of the Vines, and the very fine crops which they bore intact when I saw them, were most satisfactory. The sixth and seventh divisions were early and succession Peach houses, with a healthy lot of trees; and the last house was a mixed vinery, the sorts being principally Muscats.

In the next range, which is a new one, the first and second divisions contained flourishing young Peach trees planted in the borders, and a number of Fig trees in pots. The third division is an orchard house; the trees, which are Peaches and Nectarines, were planted in the border at regular distances, thus forming a plantation all through the body of the house. The form of the trees was that of a tall bush; all of them were very healthy, and bearing full crops of very fine fruit. The other division of this range is a Plum house, with trees of a similar form, and disposed in the same way as the Peaches; the crop of fruit was so abundant that many of the branches were bending beneath their luscious load. Some Apricots trained to the back wall had also been cropping well.

The third range presented as interesting a sight in fruit-culture as any in the garden, in the two enormous old Peach trees which occupy a large compartment of upwards of 100 feet in length. The trees are trained to the roof, one of them has a spread of fully 50 feet, and the other is larger still; I did not measure them, but I am confident I am within bounds. Both were in robust health, and well furnished with young wood from the bottom upwards; they also had an even crop of fruit, not so large, perhaps, as that on some of the younger trees, but quite large enough to be useful for furnishing hundreds of dishes for table.

In another range in the first division there were splendid young Vines with some fine fruit; the sorts were *Muscat of Alexandria*, *Gros Colman* with fruit of an extraordinary size, and *Black Alicante* fine. The second house also contained young Vines equally vigorous. With the exception of an even crop of *Muscat of Alexandria*, the Vines in the other divisions call for no special mention.

Several ranges of fruiting and succession Pine pits contained a magnificent lot of Pines; in one, especially, there was a batch of *Cayenne* all with very fine fruit. The whole of the plants appeared to be as clean and vigorous as could be wished. All the pits had simple sliding sashes about 9 or 10 feet long, and they are overlooked from raised platforms at the back of each range, so that it will be understood there is no door nor passage to any of them. In fact, their appearance is just that of ordinary brick pits, very different from the costly glass structures for this purpose so frequently to be met with, yet I very much question if the grandest modern Pine house ever contained a better average crop of fruit than was to be seen in these very humble-looking but most efficient pits.

Taken as a whole the fruit-culture under glass at Chatsworth merits the highest praise, for not only were the crops of all kinds of fruit most abundant, but from the way in which all points of excellence were developed it was evident that skill of a very high order had been brought to bear upon their management. This remark applies with equal force to every depart-

ment of the gardens; wherever one turned, order and an appearance of exquisite finish and neatness prevailed. Very rarely indeed is it that one sees a garden in which there is so little to which exception could be taken; no object appeared to be cared for at the expense of others, but all were alike most satisfactory.

To anyone travelling from Derby as I did, a visit to Chatsworth implies a most interesting and enjoyable trip, for the railway from Derby to Rowsley winds through some of the most beautiful scenery of Derbyshire, the bold character of which is very striking. Hills in endless variety present themselves to the eye; some destitute of vegetation, excepting the closely cropped turf, stand out boldly and clearly, rearing their lofty crests in most picturesque contrast to others clothed from base to summit with a compact mass of trees. Now a magnificent vista opens out along some pleasant dale, affording glimpses of other hills, with their bold outlines softened into grace by the distance; and then, as at Matlock Bath, the hills rise in lofty majesty, towering high overhead, clothed in some parts with dense foliage, among which glimpses are caught of picturesque cottages snugly perched on the steep hillside, and of places where the face of the cliff exposes the craggy strata as they dip downwards to the valley. Passing through such scenery as this the mind is prepared to thoroughly enjoy and appreciate the refinement and magnificence of Chatsworth, which impresses one as being altogether worthy of its exalted position in a county so rich in the beauties of Nature.—*EDWARD LUCHNERST, Old Lands, Buxted, Sussex.*

HEATING BUILDINGS BY HOT WATER.

THE proverbially fickle climate of the British Islands (says the *Mechanic's Magazine*), and the frequent recurrence of a damp and cold atmosphere, make the application of artificial heat to our dwellings and public buildings a positive necessity. Contrivances for producing an equable temperature within doors are consequently numerous, and in many instances they are of an ingenious character. Perhaps the best mode of accomplishing the desired end, as well as the simplest, is that of causing the circulation of hot water through iron pipes conveniently disposed for the purpose. Up to a very recent period, however, a considerable amount of hostile prejudice existed in regard to the use of hot-water apparatus, and even now the plan of heating buildings by such agencies is not fully appreciated. Imagining that antipathy to the system arises in many cases from a lack of acquaintance with its peculiar merits, we shall endeavour to explain the principles which govern the action of hot-water apparatus generally, and furnish some information as to their best form and proportions. In order to do this effectually, we must first glance at one or two of the natural laws which affect the circulation of fluids and gases. That all falling bodies gravitate with the same velocity and therefore descend through a certain definite space in a given time, is an effect of which gravity is the cause. It is from this cause that we obtain the unerring action of the pendulum. To the same source may be distinctly traced the phenomena attending the circulation of hot water through pipes, and this circulation, once created, forces all the water in the apparatus to pass successfully through the boiler by which it is primarily heated. It is upon the continuous and uniform movement of the water along the pipes that the efficacy of the hot-water apparatus immediately depends. Let us, then, inquire as to the power which insures this vitality, for without a clear perception of its nature there will ever be uncertainty as to the working of any apparatus of the kind in question. The force which produces circulation arises from the fact that the water in the descending pipe is heavier than that which is in the boiler, or, to put it differently, when heat is applied to the boiler a dilatation of the water within it ensues. The heated particles ascend through the colder ones, whilst the latter descend by reason of their greater specific gravity, and in turn become also heated. Expansion follows, and this species of action and reaction proceeds until all the particles are equally heated. It follows that the colder the water is in the descending pipe, relatively with that in the boiler, the more rapid will be its motion through the circulating pipes, and hence the diffusion of heat through their pores and into the atmosphere surrounding them.

Thus much of the general principles which control the action of hot-water apparatus as applied to the heating of buildings, and now as to their particular dimensions and details. These will naturally have to be varied with the character and size of the buildings to be heated. For churches and large structures

of a similar kind, and which have an ordinary number of doors and windows, it will be necessary in devising hot-water apparatus to ascertain, first, the cubic contents of the auditorium. Having obtained this knowledge, let the number gained be divided by 200. The quotient will yield the length in feet of 4-inch pipe required to maintain something like a steady temperature of 55°. For smaller apartments, as, for example, dwelling houses, &c., the cubic measurement divided by 150 will furnish the proper length of 4-inch pipe. These simple rules, which are the result of extensive practice and careful observation, may be safely relied upon, unless under very exceptional circumstances, and which, of course, would have to be duly considered by the constructor of an apparatus intended to meet them.

In reference to greenhouses, conservatories, and buildings of a like character, where the temperature should reach a mean of 60°, the sum of the cubic contents divided by 30 will give the length in feet of 4-inch pipe required to produce the desired effect. Forcing houses, again, must have special calculations made for properly heating them. Nothing short of a uniform temperature of 70° to 75° will suffice for such places. In order to insure this the measurement, as before suggested, must be divided by 20, the quotient being the length of circulating pipe required. For gaining yet higher temperatures, lower divisors will have to be employed, and if smaller pipes be determined upon, the length must be proportionately increased. These are points of detail, however, which may be safely left to the skilled manufacturer who may be intrusted with the making of hot-water apparatus for special purposes. Our own data may be taken as the base of calculations for economically and effectually heating buildings by means of hot water.

We are aware that some horticulturists have adopted the plan of heating their forcing-houses to a much higher temperature than that indicated above, and of allowing a greater amount of ventilation than is usual. By aid of such arrangements, it is said, a fiercer fire is obtained, but there is no doubt that this course involves increased expense in the first cost of the heating apparatus, together with a large augmentation in the subsequent daily consumption of fuel for working it.

An important consideration to the horticulturist and floriculturist is the waste of heat through glass roofs and walls. It has been found, from a course of carefully-made experiments, that 1 square foot of glass will cool 1,279 cubic feet of air as many degrees per minute as the internal temperature of the house exceeds the external temperature. Thus, if the difference between the internal and the external temperature be 30°, 1,279 cubic feet of air will be cooled 30° by each square foot of glass in the building which is exposed also to the outer atmosphere. It will be admitted that this fact should be allowed its due weight in contriving hot-water apparatus for houses wholly or partly constructed of glass. Of course, in estimating the area of glass, due deductions must be made for the sash frames and woodwork by which the panes are surrounded. If the frames and sashes be made of metal, the radiation and consequent loss of heat through them will be equal in extent to that which results from the glass itself.

The quantity of air to be heated per minute, so far as conservatories and forcing houses are concerned, should not be less than 1½ cubic feet for each square foot of glass which the building contains. When the quantity of heated air required has been thus ascertained, the length of pipe may be determined by the following formula:—viz., Multiply 125 by the difference between the temperature at which the house is proposed to be kept (when at its maximum) and the temperature of the external air, and divide the product by the difference between the temperature of the pipes (200°) and the proposed temperature of the room. Then the quotient multiplied by the number of cubic feet of air to be heated per minute, and its product divided by 222, will give the number of feet of 4-inch pipe to yield the desired effect.

CLIMBING FERNS.—No. 4. STENOCHLENA.

A FAMILY of Ferns comprising but few species, and nearly allied to Lomaria. They have long, smooth, creeping rhizomes, which fasten themselves to the stems of trees or other objects, and by which, in a state of nature, they climb to considerable heights. They produce fronds of two forms having free-forke veins, which spring from an obscure vein running parallel with the midrib, and on which in the fertile fronds the sori are situated, but, through their being so much contracted, these appear

to cover the whole under side. When placed in genial situations these plants are a great acquisition to a Fern house.

S. SCANDENS.—A noble plant, with large pinnate fronds from 2 to 3 feet in length. The pinnae are 6 or 8 inches in length, somewhat pendent, broad, oblong-acuminate, and dark shining green, the edges furnished with spiny teeth. The fertile fronds

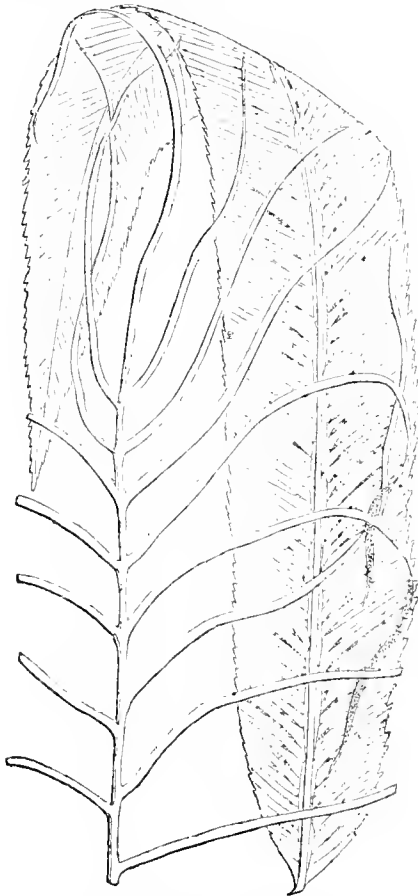

Stenochlaena scandens.—Pinna of barren frond and part of a pinna of fertile frond, medium size.

are also pinnate with linear pinnae. The latter, however, are rarely produced. It requires stove heat, and is a native of the East Indies.

S. MEYERIANA, sometimes called *S. tenuifolia*, is another very handsome scandent species, producing pinnate barren fronds; the pinnae being somewhat distant, thin in texture, serrate at the edges, and bright light green. The fertile fronds are contracted and bipinnate. It thrives in a lower temperature than the preceding, and is a native of South Africa.

S. HETEROMORPHA.—A plant of somewhat recent introduction, and too much neglected by Fern-growers. It is a very neat-growing species, producing from its thin wiry rhizomes pinnate fronds some 6 or 8 inches in length, the rhizome and rachis being clothed with reddish brown chafly scales. The pinnae are sub-rotund, becoming oblong in old plants, petiolate, and have the margins deeply dentate. The fact of its being a small-growing plant and succeeding well in a cool house, should recommend it to the favourable notice of all Fern-cultivators. Its fertile fronds I have never seen. Native of New Zealand.

NEPHROLEPIS.

This genus contains some very handsome species which should recommend themselves to the notice of lovers of Ferns, from the rapidity with which their long wiry rhizomes climb over and about the walls or any rough surface in the fernery, and soon give the house a furnished and established appearance by draping them with beautiful, pendent, dark green fronds. The genus *Nephrolepis* is distinguished by its long, creeping, wiry rhizomes and pinnate fronds, the pinnae of which are articulated and sessile; they have free-forked veins and round sori, which are furnished with a reniform or orbicular indusium.

The species of *Nephrolepis* are stove Ferns of remarkably rapid growth; they produce long stolons which form young plants at short intervals, and these again produce others, so that in ferneries of limited extent, in which the plants are not grown in pots, some care will be necessary to prevent their overrunning and destroying other and more slow-growing kinds. I am not an advocate for withholding water from Ferns, and neither will this genus suffer such treatment with impunity, for on account of the pinnae being articulated with the rachis they readily fall out of their joints if neglected, and the consequence is the cultivator is rewarded by bare stems instead of bright green cheerful fronds. When grown as pot plants a mixture of loam, peat, and sand suits them well; but when planted out in the rockwork of a natural fernery they are by no means particular, but attach themselves in any moist crevices, and send down roots until they reach a genial soil.

N. HIRSUTULA.—This is an exceedingly interesting and elegant species, yet somewhat rare. The fronds measure from 18 to 36 inches in length, lanceolate in shape, pinnate, and sparingly clothed with reddish brown hairy scales; the pinnae are about 3 inches in length and full green. It is a native of the East Indies.

N. PECTINATA.—An elegant slender-growing kind, which quickly drapes a wall or pillar with its light green pendent fronds. These are from 18 to 30 inches in length and pinnate, with the pinnae much crowded, oblong, and dentate at the edges. Although this plant is somewhat common, on account of its being so readily increased, it is, nevertheless, very handsome either planted in the open fernery or grown in a pot. It is a native of various parts of tropical America.

N. DAVALLIODES.—This is the largest and strongest-growing species in the whole genus; the fronds are from 1 to 4 feet in length, pinnate, with beautifully curved pinnae from 3 to 6 inches in length. The barren pinnae are slightly dentate at the edges, much broader than the fertile ones, and dark green; the fertile pinnae are narrow, deeply lobed at the edges. Upon the apex of each lobe the sori are situated, producing an effect somewhat similar to that of *Lygodium*. In a young state the plant produces only sterile fronds, but as it attains maturity the upper portions become fertile, and ultimately a few barren pinnae are only developed at the base. It is a very fine plant, and a native of the Malayan Archipelago.

N. UNDULATA is a tuberous-rooted plant, producing fronds from 12 to 18 inches in length. The pinnae are narrow, oblong-acuminate, and at the base slightly cored on the upper margin, and crenate; colour light green. This is a very elegant dwarf-growing species. It sheds its fronds in winter, and care must be

taken that the tubers are not dried too much, or they will be found in spring quite dead. Native of West Africa.

N. ENSIFOLIA.—A robust handsome plant. Fronds pinnate, from 12 to 30 ins. in length, and somewhat pendulous. Pinnae about 4 inches long, sword-shaped, and bright green. It forms a beautiful specimen in a pot, but displays its full beauty when climbing over rockwork or upon an artificial pillar in the stove fernery. Native of the East Indies and South America.

N. EXALTATA.—This is perhaps the commonest species of the whole genus, but at the same time one of the handsomest. It succeeds admirably in almost any situation, but if planted out it must be checked from extending itself to the detriment of the other plants. Its fronds are from 1 to 3 feet in length, or even more, and some 3 inches broad, linear lanceolate, serrate at the margins, cored at the base on the upper

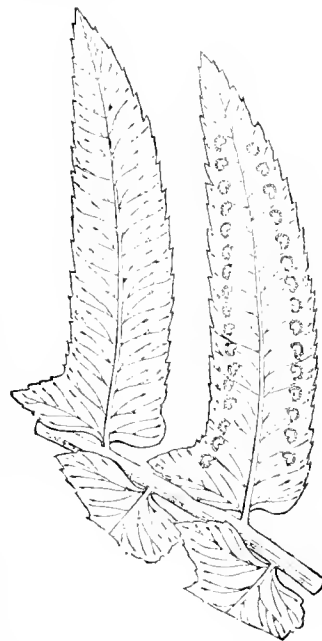

Nephrolepis exaltata.—Part of frond full size.

lanceolate, serrate at the margins, cored at the base on the upper

side, and bright green. It seems to be widely distributed throughout tropical America and the West Indies, and is also found in the Sandwich Islands.

N. FALCIFORMIS.—A rare species, and its rarity is much to be regretted, for it is robust and handsome. The fronds are from 2 to 3 feet long, erect, and arching. The pinnae are broad and falcate, slightly corded at the base, and dark green; the sori are nearly round, and situated in a single row close to the margin. It cannot be too highly recommended for climbing over rock-work, and it also makes a fine specimen as a pot plant. Native of Borneo.—**ESPERO CREBIA.**

WORK FOR THE WEEK.

KITCHEN GARDEN.

DURING frosty weather wheel manure on to the different quarters that require it; throw it into convenient heaps, and cover it with earth like a Potato pit, so as to prevent waste from evaporation. It greatly facilitates spring cropping to have the manure at hand, instead of having to wheel it when wanted. Soil that has been ridged up would be benefited by the ridges being turned over with a fork, the more fully to expose it to the action of frost. Turn compost heaps of all descriptions; one turning in frosty weather is worth three in the absence of frost. The occupation of the ground by crops suitable as food for a variety of insects, in the course of a series of years brings a vast number of such depredators into a garden. The invention of methods for their extirpation often taxes the ingenuity of a gardener to a considerable extent, and caution must be exercised in the choice of material. There is, however, one substance not open to any objection, and which may now be used with advantage to land whence the crop has been removed—viz., lime. Ground cropped in the preceding season with Carrots, Parsnips, or Potatoes, and found, as is frequently the case at this time, infested with insects, should have a good dressing of lime dug in; or if that cannot be afforded, the soil should be turned up in ridges for the winter. Birds are the natural enemies of grubs. The services of a few rooks or sea gulls, where they can be secured, would be found of no inconsiderable value. Take advantage of dry days to tie advancing *Endive* to blanch. *Globe Artichokes* should be thought of. Examine young *Lettuces* frequently, and dust with lime or soot to check the attacks of slugs. A stock of leaves should be variously distributed amongst those crops requiring protection. A reserve of leaves should be kept on hand for *Sea-kale* covering, linings, &c.; in fact, a good heap of leaves is one of the requisites of a kitchen garden. As this is the season alterations in estates are generally in progress, the opportunity of collecting soil or material suitable for storing for the garden should be taken advantage of. Turf, road sand, and brick rubbish, are all valuable, and the chance of making a reserve of such should be eagerly taken.

FRUIT GARDEN.

Proceed with the planting of fruit trees in open weather, and if the soil is old let each tree have a good portion of new soil about its roots. Pruning and nailing all kinds of wall trees, except Peaches and Apricots, must now be vigorously prosecuted. Leave nothing for the spring which can be done now; every day gained at this season will give greater liberty for extended operations in the spring.

FLOWER GARDEN.

A little labour will secure a valuable supply of material for enriching the flower beds and borders. Leaves are everywhere at hand; they should be sedulously collected and stacked in some out-of-the-way place with a mixture of road sand or light soil, rotten sticks, and decaying vegetable matter, and left to ferment. In a season or two a most valuable compost will be the result, especially suitable for many of the shrubs and plants which decorate our gardens, whose original position was probably near some primeval forest, the ever-accumulating leaves of which would naturally give a character to the surrounding soil, and encourage the propagation of *Rhododendrons*, *Azaleas*, *Magnolias*, &c. A thorough cleaning should once more take place in all pleasure grounds, as by this time all the decayed leaves are down. Rose stocks may now be procured and planted; they will transplant safely at this period, provided the roots are kept damp. *Fuchsias* in beds or borders may be cut down and mulched over; if it is desired to preserve any large specimens with their tops, a row of stakes may be driven round in a circle and surrounded by a mat, the interior being stuffed loosely with clean new straw. The top of this

may be thatched to exclude wet. Before enclosing, however, it will be well to pluck off the leaves, as these encourage mouldiness.

GREENHOUSE AND CONSERVATORY.

In frosty weather the conservatory will require very careful management, for some rather difficult problems have to be worked out. Atmospheric humidity cannot by any means be entirely dispensed with, yet if not well managed it will produce damp, which is very prejudicial to the delicate texture of *Camellias* and other gay flowers. Of course, if the exterior of the roof has no eaveing ice will gather on the glass, and in melting will drop from the laps. The best plan is to keep as low a temperature as can be allowed—say, 40° to 45° at night, and to give a little back air at night, also a little at front, but it must be very moderate, as the atmospheric moisture, instead of passing quietly away by the back apertures, will be condensed as it rises. With a good roof-covering, 40° would be quite sufficient, and then there would be enough atmospheric moisture at all times without the special application of water. See that the young stock of *Heliotropes*, *Scarlet Pelargoniums*, *Persian Cyclamens*, with other flowers grown especially for winter, have light situations, and regular, close attention as to watering. Let *Eucyas* also have attention in watering; if they stand near flues or pipes they may become suddenly very dry. Keep up a quiet ventilation in the greenhouse day and night if possible; let the air steal in moderately, and dispense with strong fires, or, indeed, fires of any kind when the temperature can be kept within the limits without them. Do not water the *Pelargoniums* until they are thoroughly dry, and take care to fumigate frequently and slightly.

FORCING PIT.

This is a good time to introduce the following plants, provided, as before observed, they have received the necessary treatment through the summer:—*Rhododendrons*, *Azaleas*, both American and Chinese, *Persian Lilacs*, *Sweet Briars*, *Moss* and *Provence Roses*, *crimson* and *Perpetual Roses*, *Lebanus*, *Kalmias*, *Anne Blyen Pinks*, *Wallflowers*, *Sweet Williams*, and *Dutch bulbs*. Unless, however, they are in proper trim, it will be labour in vain, and no mode of forcing nor form of pit can compensate for this. If the heat is wholly produced by fermenting materials, keep down accumulating damp and mouldiness by an almost constant ventilation, increasing the linings in order to raise the necessary temperature. Those who possess tank-heated pits will pursue a somewhat different process; such will scarcely need my advice. If there is any prospect of a scarcity of bloom next May, a portion of the *Achimenes* and *Gloxinias* should be repotted at once and placed in the forcing pit, choosing such as have been the longest at rest. A few *Clerodendrons*, *Allamandas*, and *Eclites splendens* may also be started, but unless plants of those with well-ripened wood are at command, and that have been some time at rest, there will be nothing gained by attempting to start them into growth at present, for in most cases it is difficult at this season to maintain a sufficiently warm temperature to secure anything like free growth from these unless the plants have been well prepared for an early start. A gentle bottom heat of about 80° or 85° will be of great service to such plants, in inducing a healthy root-action.

PITS AND FRAMES.

If former directions have been carried out the plants in these structures will present a dwarf and robust appearance, thus being well fitted to bear deprivation of light for some time, if severe weather should ensue. Damp has accumulated very much of late, owing to the heavy rains and the dense fogs with which we have been visited. This may be removed by giving air at the front and back on sunny days, but where the pits are heated with flues or pipes, a dry atmosphere may be obtained by putting on slight fires, at the same time allowing a free circulation of air amongst the plants.—**W. KEANE.**

DOINGS OF THE LAST WEEK.

KITCHEN GARDEN.

OUR work was very much the same as in previous weeks' notices, in the way of protection, forcing *Sea-kale*, &c.—wheeling during frosty mornings, preparing heaps of fermented material, digging, trenching, and covering *Asparagus* with a light layer of dung and litter, as the roots are rather near the surface.

As yet the frost has not been so severe as to render *protecting Celery* necessary, but after such mildness of weather it will

be more easily injured. What we planted late has gone on better than we expected, owing to the mild weather. We could not plant earlier, having no water to give. Our earliest beds, protected from the drought by shading, have done very well, not showing a single bad or bolted head.

Large Lettuces are so placed that protection can be given; younger ones and smaller Endive are doing well, especially on ridges. Young Lettuces sown late often stand the winter well, when sown rather thickly on ground merely-scratched over, not dug or forked-up; the firmness of the ground is a great means of giving firmness and hardness to the young plants.

FRUIT GARDEN.

More care than usual is required in the *fruit-room* this year. Apples, on the whole, keep remarkably well. Pears keep worse than usual, and ripe earlier. One fruit allowed to rot will soon injure a lot more in its vicinity, especially when the room a command will not permit of the fruit being laid down separately. Why should there be such a difference in the keeping of Apples and Pears this season? We might suppose in the case of the Pears, that after swelling but little in the dry hot weather, they swelled too rapidly after the damper weather came, and were thus overcharged with watery juice, and early ripening and decay were the consequences. But, then, why would not a similar cause act on the Apples, which, on the whole, are keeping as well if not better than usual?

Late Grapes we find want frequent looking over, as each tuted berry is likely to taint the next to it. As soon as the leaves turn yellow they should be removed, at first the most yellow ones, as whilst any green remains they keep up a slow up-movement, and in orchard houses where there are late Grapes, the leaves above the bunches, though the leaves are turning yellow, act as a protection to the bunches in sudden changes of weather. Unless, however, where there is some simple mode of heating so as to keep out frost, it would be well to clear orchard houses of fruit by the beginning or middle of November, as a little frost soon injures a bunch of Grapes. There is no difficulty in this respect in a heated house, as a little fire will easily keep the temperature at about 40° at night. At this season a little fire with a fair amount of air will be desirable every day, except in bright sunshine. Unless frosty, very little firing should be given at night, and unless the frost is severe, a little air should be left on the house all night. Very little air will prevent the enclosed atmosphere becoming stagnant. If a fire has been put on in the morning and burns brightly, and the sun is also bright, the air of the house may become too dry, so as to scorch and shrivel the berries. In such a case, instead of admitting too much cold air, if frosty it may be advisable gently to dew the paths, stages, &c., from a fine syringe, so as to counteract the extra dryness. This will seldom be needed except in such a case as the above, where bright sun heat and strong fire heat are allowed to meet and work together, which should in every case be avoided. As a general rule damp is the thing to be avoided, and hence Grapes will always keep best where no plants are put in the house, with their necessary and attendant waterings. Where plants had to be put, as in a greenhouse, with Vines on the roof, and where it was desirable to keep some bunches as late as possible, we have seen this well managed by enclosing the bunches in bags, large for the size of the bunch, made of silk paper, or book-muslin, so glazed with starch, &c., as to keep out the damp. A small opening in the bag was left at the stalk of the bunch, so that the air round the bunch should be in movement, whilst the damp of the house could not act freely upon it.

Many will now be thinking of commencing to force Vines, Peaches, &c., but the majority of those for whom we write will do little in this way until the turn of the day, or until January and February are pretty well gone. In all such cases there will not be such a difference in the ripening time as would in an economical point of view compensate for the greater trouble and outlay. There will be some, however, who will grudge no expense to obtain early results, and they cannot commence too soon after the houses are thoroughly cleaned, as lately advised and commented on. It must be kept in mind, especially at this dark season, that the temperature of such houses should be raised very gradually, and rather more moisture should be given in the house by syringing than would be actually required by the increased temperature until the buds have not only swelled but burst. Some persons boast of doing their forcing in a slap-dash manner, raising the temperature quickly, and acting somewhat in derision of the slowcoaches, who are frightened at a good heat. Slow and sure, we would advise all beginners to take as their motto. If they begin with a vine

at 45°, let them take a week to raise it to 50°, another week to 55°, and keep the house ranging from that to 63°, until the buds have swelled and broken.

Pruning the hardier fruit trees, nailing, &c., may be proceeded with now in all favourable weather; we dare not prune so much as we wish, owing to the ravages made on our fruit buds by birds and other fourlopers. We suppose that there are always some disadvantages to be met with everywhere. Trying to preserve the buds of fruit trees has been a serious matter with us for years. Even now some fine pyramid Plum trees, bristling a fortnight ago with fruit buds, are already greatly injured. Wherever feeding game largely close to a garden is followed there will be multitudes of four-footed and winged depredators when the most telling means of defence are prohibited. During the summer we visited a garden nearly as much surrounded with wood as this is, but where we know as a fact that scarcely a fruit bud or a fruit is ever touched. On our visit ventilators, close to the ground, of vineries were left open night and day. Had we done so for a single night we should have expected a scene of desolation in the morning from mice, rats, and birds, not to speak of less birds, even thrushes and blackbirds delight to get at a bunch of Grapes. Whence the difference? Partly because there was no attempt to feed or bring up game in the neighbourhood of the garden, but chiefly owing to a number of cats, that were eating their allowances of scraps from the kitchen behind one of the sheds. The cats were so fed that they had little temptation to go beyond the garden, and at the same time were not so overfed but their presence and walking about kept even birds at a distance, whilst mice were kept out of sight. The claws of a cat or two are the best of all vermin traps in a garden; but in many a garden cats, however tamed, domesticated, or even ringed or chained, must be denied a home. There is no doubt that when given to wander, the cat is a sad rover in a game preserve, but well treated, as in the garden just referred to, we have known them help for years without staying much beyond their allotted boundaries. Besides, when kept, as a matter of course, it would be easy when used to it to shut them up at night. Although no doubt there are many exceptions, yet it may be laid down as a general rule, that when a cat is disposed to wander, it abuses those hours for its purpose when its master or mistress has gone to bed. A cat is not all gain; even in a garden it will search a little at times; but for catching and deterring in a kitchen and fruit garden, a good cat is worth its weight in silver. How many of our readers are now distressed about their buds in their little gardens being destroyed? They may trap and poison as they will, but there is no such security to be found as in a watchful cat.

On the same day that we saw the cats in one garden, we saw a sight in another garden which we shall never forget. Mr. Sage, at A-bridge, had taken off the lights from a large lofty beam-to Peach house. The Peaches were a fine crop, all nicely arranged, and fully exposed on the upper side of the trellis, swelling, colouring, and ripening well. With such a complete exposure we could fancy how rich the flavour would be. Had we had a similar house, we should not have ventured on similar treatment. In a single day we should have expected every fruit to have had a hole in it. Even on leaving a door open for more air, not to speak of less intruders, we have had pheasants visiting, thinking, no doubt, they might have a taste as well as their betters, and smashing the glass to escape when discovered. In that large kitchen garden we did not observe a single bird. We could recollect of a garden where you could scarcely traverse a walk without a dozen blackbirds screening out defiance, and vaulting over a wall only to come again when your back was turned.

ORNAMENTAL DEPARTMENT.

We must here content ourselves with a few hints. First, to window gardeners. Keep leaves and stems thoroughly clean by freeing them from dust, and softly washing with clear water at from 60° to 65° in temperature. If you try Chinese Primroses, do not over-water them, and keep the water from the collar of the plant. If the water gets into the saucer empty it out. As respects Scarlet Geraniums, unless in bloom, they will need little water. If you try Cinerarias, if you do not put a little moss in the saucer, you may allow about the eighth of an inch, if not more, of water to remain in the bottom, and you cannot sprinkle the foliage too often if there is fire in the room. If you use bulbs, keep them in the dark until roots are freely formed, and the flower-stems showing, then the more light they have the better. True, they will come all the sooner if kept on the chimney-piece, or near the fireplace, and they will even

bloom there, or on a table, or any corner where you choose to set them; but all this will be done chiefly at the expense of the stores laid up in the bulb. Would you enjoy the beauty of the bulbs in connection with the feeling that you are doing what you can to make them comfortable, then let them expand their blooms in all the direct light you can give them.

Plants in frames and cold pits will scarcely need a drop of water. In particular cases take the plant out, water, and when drained replace it.

In plant houses avoid over-watering and over-heating, and spill as little water as possible. In dull cold days a little fire heat with air will be more useful than much fire heat at night, when it can be avoided. Unless where plants are to be forced, proportion heat to light as a great rule not to be departed from.

Laurels and Emergents.—We pruned and cut these down, as the leopius were wanted for a particular purpose. As in the case of a correspondent the other week, the Laurels here, to be kept healthy and vigorous, require frequent lopping and cutting. In ordinary winters all such work may be done safely now. If we were sure of a very severe winter we would prefer doing such work rather late in spring, just before the sap begins to rise freely. In cutting large limbs now it is advisable to dab up the cut parts to prevent frost exposure and cracking. Clay and a little lime as a thick paint do very well, a little oil paint does better. When the fresh shoots break from beneath the cut part all danger is over, but we have seen stems of Laurels from 4 to 6 inches across killed to the ground from wet and severe frost acting on the exposed cut end.—R. F.

TRADE CATALOGUE RECEIVED.

Dick Reade & Co., 129, High Holborn, London, W.C.—*Illustrated Sheet of Horticultural Decorations.*

TO CORRESPONDENTS.

*** We request that no one will write privately to any of the correspondents of the "Journal of Horticulture, Cottage Gardener, and Country Gentleman." By doing so they are subjected to unjustifiable trouble and expense. All communications should therefore be addressed *solely to The Editors of the Journal of Horticulture, &c.*, 171, Fleet Street, London, E.C.

Books (C. Bell's).—Lowe's "Ornamental-foliated Plants," contains coloured plates; any bookseller can obtain the volume for you.

REMOVING PEAR TREE (Amateur).—Remove it immediately, injuring the roots as little as may be, mulch over the roots. Graft a portion of the branches next spring, and the remaining branches the year following.

PYRAMIDAL TREES (J. Lawson).—If you write to Messrs. Rivers & Son, Nurseries, Sawbridgeforth, they will tell you.

LEAVING GERANIUM CUTTINGS IN THE OPEN GROUND (C. J. S.).—We do not think the cuttings will survive the winter, though they grow in a sheltered spot, and are to be covered with fern or hay in severe weather. It is, however, worth a trial—that is, if you can spare the plants.

AZALEA LEAVES TURNING YELLOW (Julie).—Do not despair. The plants at this season usually lose a portion of their leaves, and there is no great harm in it, only keep them cool so that the injury will be needlessly started into fresh growth before the flowers expand. The Madame Saundersii, for which you have no stove, keep in the warmest part of the greenhouse, and give but little water—only a little occasionally to keep it fresh. We have it now in fine bloom in a stove.

TRANSPLANTING LARGE MAGNOLIA (W. W. M.).—We think you have done all that could be done, all that we consider needful to ensure success, which we think you have good reason to hope. Much larger Magnolias have been moved successfully. See that the wires you employ for keeping the plant steady do not chafe the stem. Protect the stem with hay, and wrap it in one from the base upwards, fully two-thirds of its length. It will help to assist the flow of the sap in spring.

ASPARAGUS KALE (L. M.).—The part that gives the name of Asparagus to this desirable vegetable are the side shoots, that will by-and-by make their appearance, and when 3 to 6 inches long they are broken off like Brussels Sprouts; and when cooked whole and kept in brine in the dish have a nice appearance, and are very delicate with a slight Asparagus flavour. The heads you now think of cutting are very good cooked like other kinds of Borecole. There is no substitute for Asparagus, nothing that has an appearance like it, or can be mistaken for it in flavour.

PREPARING GROUND FOR ONIONS (Idem).—The soil being poor, give a good dressing of manure and dig it in deeply and well now, throwing the ground up roughly for the winter. In February throw the ground level, forking it over on dry frosty mornings; early in March mark out spaces 4 feet wide with 1-foot alleys between, and give the beds a coating of very rotten manure about an inch or two thick, and pack it in with a fork. If you think fit you may give each bed of 13 yards in length a bushel of pounded charcoal; then throw out the alleys over the beds, rake level, and sow in drills about 6 inches apart in the second week in March.

LEAVING SALSIFY IN THE GROUND (Idem).—It will not injure Salsify to leave it in the ground, but it is much better taken up and stored in sand in a dry shed. It is then always at hand for use as required. The

soil cut and stacked last March will be better than that fresh cut for many purposes, but for border-making and plants not requiring frequent shifting we like turf fresh.

PLANTING HOLLIES (Commander).—The height of stem to be covered with soil is simply no more than is required in covering the roots with soil—not more than 3 inches. That depth of soil over the roots is quite sufficient, more is injurious.

PLANTS FOR A STOVE (Idem).—There is scarcely any plant that will not succeed in a stove with a temperature in winter as low as 55°. We give a few names of the most select, both for foliage and also for their flowering. For foliage: *Abocasia metallica*, *Ananas sativa variegata*, *Arceuthobium*, *A. Verschaffeltii*; *Clanum asperatum*, *China borea* Ernstii-Angustii, *Cocos coronata*, *Cissus discolor*, *Croton bicoloratum variegatum*, *C. irregularis*, *C. intertrupta*; *Craonophyllum maculiferum*, *Cycas circinalis*, *Dialium Pearcei*, *D. Weltri superba*; *Draena ferrea*, *D. stricta*, *D. Cheisoni*, *D. regia*; *Ficus dubautia*, *Maranta illustris*, *M. roseo-picta*, *M. Veitchii*; *Musa Cavendishi*, *M. En-ete*; *Pandanus javanicus variegatus*, *P. elegantissimus*; *Synedrella nobilis variegata*, *Terminalia elegans*, *Thrinax elegans*, and *Verschaffeltii splendens*. For flowering plants: *Allananda grandiflora*, *A. S. Schottii*; *Anthurium Schimperianum*, *Ardisia crispifolia*, *Bougainvillea planicaulis*, *Burchardia major*, *C. robustiorum* Polakianum, *Cyatula lucida*, *Cyatocarpus richardsonii*, *Calceolaria R. Robinsonii*, *Eucalyptus amabilis*, *Euphorbia japonica*, *Fraxinea confertiflora*, *Gardenia cuthbertii*, *G. fluida*, *G. radicans major*; *Gesneria exoniensis*, *Hoya bella*, *H. carnea*; *Ipomoea Horsfallii*, *Ipomoea caroliniana*, *I. coccinea* Zapfen, *I. fluida*, *I. javanica*; *Jasminum gracilis*, *Mexantia erecta*, *Medinilla magnifica*, *Rosea gracilissima*, *Rondeletia speciosa major*, *Stephanotis floribunda*, *Tournefortia asiatica*, *Vibea alba* and *Vibea rosea*.

PERLWARTIA LEAVES SPOTTED (Thos D.).—The only remedy for the spot on *Perlwartia* leaves is to remove the diseased part, moisture on the leaves. The moisture may be wintered a close thin glass or condensation. Your only remedy is to give them a position near the glass and a slight abundance of air, keeping the atmosphere as dry as possible; indeed a little air at night, so as to keep the moisture from condensing on the leaves, is good. Water carefully. A temperature of 41 to 45 is sufficient at this season.

CLEMATIS AND PETERRA PLANTS LIVERY (Thos D.).—V's would keep the Clematis at the root from now until February, not, however, so dry, to cause all the leaves to fall, and then we would cut it back, giving as a much better time to heal back than at the present. The Peterra, but we would not root, though you may do so, and secure more plants. We would let the shoots grow until long enough to be detached, in order to make new plants.

FRANSES FOR LATE USE (J. T.).—Your Peach tree, from the description, is probably Late Admirable. The stringing earth is as late, if not a later kind. Barrington is also good, but not so late. Waltham Admirable is late, but is a shy bearer. Lord Palmerston and Lady Palmerston are first-rate late sorts, new kinds raised by Mr. Rivers.

BLENDS FOR A GREENHOUSE (C. B. M.).—The samples sent are more suited for protecting well trees than for blimes for a greenhouse. If you want to keep it cold, we should prefer No. 1. For placing inside as blime, we should like the picture; they look so snug. Merely to break the force of the sun nothing is better for the inside of a house than black-melina, hoisted and stretched in pieces by rings. Such blimes would require to be removed from October to April. Perhaps we do not quite understand your aim.

GREEN VINERY (C. B. M.).—There can be no doubt of ground vineries being a success. From 7 to 9 feet is a good height for one Vinery; by adding several you can make what length you like. By raising the frame or pillars in the ground, you can make the ground enclosed so partly at least for the roots. Covering the ground with dirt is useful for retaining heat, and if the slate be painted with sulphur it will keep the Vinery free of some enemies. We care little as to the different merits of wood and brick, only in stony weather the brick retains and gives out the heat longer. One Vinery would do for a length of from 7 to 9 feet. If we were to plant in the second manner, we would cut back the Vinery to, say, a foot or so after planting, and grow to the roof the first summer. You can easily purchase strong Vines that would beat the first summer, but to succeed you had better plunge the pot, then break it all round, and surround with the good compost; or if you plant in, do not disengage the roots much. The hardest sorts are the best—such as the Black Hamburgh and the white Royal Muscadine. All the hardy kinds will succeed. The simplest mode, as in the earthen's Vinery, is to leave the ventilation on all the summer. The partitions between the Vines might be partially shut up in winter, if you prefer to other things inside or outside. You will get information on these little places, and on growing Vines generally, in the "Vine Manual," published at our office by G. S. We would by no means think of having a row of your entrance in a row of ground vineries, but if we had a wall or wall facing the south, and that fence was 7 feet or more in height, we would sooner plant it with glass, and then you could walk inside and tend to the Vines in all weathers.

PLANTING VINES IN A HOUSE (L. Poor Working Man).—By planting inside you will avoid many evils which we are forced to contend with. You may have all the border inside if you like. You may let the roots outside to, if it is suitable to have a border there, by having the front sill on planks or benches. The method of forming the border is correct, only you should have a drain beneath the rubble. You need not sink down much, if you can easily raise the border above the ground level. If it were to be a wall to have a border outside, and you were under the necessity of having the roots all inside—a cool plan when watering and rich substances and being attended to—then, even if we used the whole of the floor for a border alternately, we should be satisfied with the present proposed arrangements, and in three or four years we would add a bit more to the border inside, and that would be the giving cattle a fresh pasturage. If you have room enough above, there will be no benefit in taking out a deep hole for the border. You must do so to a certain extent, we presume, to secure the drainage.

FUEL FOR FIRELESS STOVE (M. L.).—Neither that you mention nor any other can be burnt in a conservatory, greenhouse, or any structure containing plants without burning those plants. All fuel when burnt produces carbonic acid gas, and this in excess causes the leaves to turn yellow, and to some plants brings death.

IRISH PEAT CHARCOAL.—Several correspondents ask where they can purchase Irish peat charcoal, so strongly recommended in Mr. Cuttill's manual of market gardening. Anyone who can supply it would be repaid for advertising it, stating price, &c.

TAKING UP GLADIOLI (Bertram).—Your soil being "black loam, subsoil sand, on the Mansfield stone," there will not be any danger of leaving them in the ground, but we would top-dress with partially decayed leaves.

VARIOUS (Amateur).—1. The cause of the Calceolarias, Tom Thumb Geraniums, and Lobelias doing so badly in your soil, is no doubt want of limans. Give it as much leaf soil or well-rotted manure as you can now, and work it well into the ground, digging to a good depth. 2. The glass placed before the Calville Blanche cordon Apple trees should be removed from now until spring. 3. Having no greenhouse, your only plan of forwarding Tomatoes and Celery is to sow the seeds in February, and growing the plants in a hotbed, pricking off the Celery into pans when large enough to handle, and potting-off the Tomatoes in small pots, growing them in a hotbed, and hardening them off by May. 4. Budded and grafted Pines, Pear, and Apple trees may be moved in the autumn succeeding their working, and in the case of grafted trees, will be maiden trees, but the budded ones will not be maidens until the autumn following, and it is well not to move them until they have made a year's growth. 5. Quince stocks are propagated from cuttings and layers, and also suckers, choosing young wood for both the cuttings and layers, and planting or laying off once. The Paradise Apple stocks are raised from cuttings, putting in in February cuttings of about 10 inches in length, with a short heel of the previous year's wood.

POUNDED OYSTER SHELLS FOR CINERARIAS (One Anxious to Learn).—It is well to mix them with the compost in the proportion of about one-sixth, but they should be calcined. They are not equal to watering with liquid manure; but watering often with that is not good for anything, unless the liquid is very weak. Giving it twice or thrice a week is quite often enough, and we find one good watering better than constant applications. The plants require time to elaborate the food given them. It is necessary to give both the oyster shells and liquid manure, the latter when the pots are filled with roots, at every alternate watering, or once or twice a week. Oyster shells are good for mixing with the soil for Chrysanthemums, also Felargoniums, and almost, if not all, pot plants, except those, perhaps, that require peat soil.

CHRYSANTHEMUM SEED SOWING (Berthampstead Subscriber).—Sow in March in pans of light sandy rich soil, and place in a hotbed. When the plants appear give abundance of air, and keep them near the glass. When large enough to handle prick them off about an inch apart in pans, and return them to the hotbed or a cold frame. Shade them for a few days, then harden them off, plant out in June in an open situation, and water them in dry weather. In autumn the plants may be taken up and potted, and be wintered in a cool house or frame. They will need to be potted and then growth encouraged the second year, and in the autumn they will flower. The "Encyclopedia of Gardening" is published by Messrs. Longman, price 3s. 6d.

CLEANING NEGLECTED GARDEN—FRUIT TREES UNPRUNED (E. M. J.).—As the soil is good we would not burn the top spit, but at once trench fully two spits deep if the soil is good to that depth, or as deeply as you can without bringing too much of the bad soil to the top. If this were done between now and February, the ground would be in first-rate order for planting with Potatoes. The leaf soil will answer very well as manure, placing it over the Potatoes in the drills, and we would supplement it with guano, at the rate of about 3 cwt. per acre. It would give them a start. Sow it broadcast. The wall trees thirty-five years old we would grub up, and replace with younger trees. There is poor chance of your cutting them into form after being so long neglected. We would not plant fruit trees after February, if we could help it, but have planted very successfully in March. We would trench the borders, and clear out all the old roots we could find. It would be well to dig a hole for each tree, and pave the bottom; it would cause the roots to spread, but would not prevent their going down; to prevent their doing so the interstices between the stones should be filled up with concrete. The planting with chopped sods and fresh soil is good, top-dressing with rich manure. For a south and east aspect in the north midlands of Ireland, we advise for the south wall:—*Apricots*—Hemskirk, Kaisha, and Moorpark. *Peaches*—Noblesse, Grosse Mignonne, Violette Hâtive, Malla, Barrington, and Early York. *Plums*—Early Favourite (Rivers's), July Green Gage, Green Gage, Jefferson, Transparent Gage, and Angelina Burdett. *Of Pears*, for the east wall, *Beurré d'Amaldis*, *Calebasse d'Été*, *Marie Louise*, *Gloa Moreau*, *Dr. Troussseau*, *Beurré Diez*, *Beurré Bachelier*, *Beurré d'Arcenberg*, *Beurré de Rance*, *Winter Nclis*, *Joséphine de Malines*, *Van Mons Leon le-Clerc*, and *Ne Plus Meuris*. If you wish for more *Plums*, *Belgian Purple*, *Prince Englebert*, *Ondlin's Golden*, *Victoria*, *Kirke's*, and *Coc's Golden Drop*, will suit; and if for *Nectarines*, *Etrange*, and *Violette Hâtive*, will succeed on the south wall.

PRUNING DWARF FRUIT TREES (An Amateur).—We should not prune more than is necessary to give them the required shape. The less pruning bush and pyramid fruit trees have in winter the better. Of your two plans, we consider the pruning but little the better, and we think the notching over the buds will not interfere with their breaking. The inverted \cup is the proper way to cut the notches; the straight cut, or directly across, is more likely to result in the shoot being broken above the bud at the cut. We question very much the soundness of the notching system. In the end we fear it will lead to gumming and canker, and if not, the shoots will ever be liable to breakage.

HELIOPTROPE LOSING ITS LEAVES (Arlins).—It is usual for the Heliotrope to lose its leaves at this season, and it is well to give no more water than a little occasionally to keep the wood firm. The plant ought to have a temperature of not less than 35°, and if you require flowers at this season, 45° to 50° are necessary, the soil being kept moist, and in favourable weather abundance of air given. The plant, however, ought to have rest by being kept cool, yet safe from frost, and comparatively dry at the roots, pruning before it is again excited into growth. Thus treated, it will grow and flower more freely and strongly than when otherwise managed. We are unable to account for the Roses in pots throwing out shoots about half an inch long and then withering. Are they not potted with the junction of the stock and scion above the soil? It ought in all cases to be covered with soil.

CORREA LEAVES FALLING (Delta).—It is a result of imperfect root-

action, and may be caused by bad drainage, giving too much water, and so saturating the soil, and sometimes by want of water in summer. The chief cause, however, is scale, which, by its secretion, causes honeydew on the leaves, and their pores being closed they fall. The temperature in which the plants are is too high; 40° to 45° will be sufficient at this season, and with that, a light, airy situation, and water enough to keep the soil moist, the plant does well. The hot dry season has been very trying to all plants of this class. In summer it is desirable to grow them in a cold pit. Keep your plant dry, giving no water except when the soil becomes dry, then supply enough to show itself at the drainage, and we think it will recover. Repot in March, and keep the plant cool with plenty of air.

FORCING SPIRÆA JAPONICA (G. O.).—The plants will flower early in February if placed, at the beginning of December, in a house with a temperature of 45°, increased to 50° in a fortnight, and then to 55° in another fortnight, if afforded a moist atmosphere and the needful supplies of water. The temperatures named are from fire heat.

SNOWBERRY AND CORCHORUS JAPONICUS PAUNING (E. M. J.).—It is scarcely possible to prune these so as to look well. The only plan that we know is to well cut out the old wood, and then prune the parts remaining, so as to form compact bushes. The long shoots of the current year may be cut in one-half or two-thirds their length, and the side shoots shortened much in the same way as Roses. The Snowberry, however, need not have the side shoots shortened; thinning them and shortening the long and straggling shoots will be sufficient. If they have spread considerably from the main plant by suckers grub these up, leaving the most compact bushes. Spring is the best time to prune the Corchorus. Just before it begins to grow, and any time during the winter, will suit the Snowberry.

PEACH TREES INFESTED WITH BROWN SCALE (J. R. D.).—The trees being at rest, paint them with a solution of 8 ozs. of soft soap in the gallon of water, applying it with a brush at a temperature of 120°, and being careful not to dislodge the fruit buds. A few syringings with water at a temperature of 100° will answer quite as well, but the soft soap is a great antidote to the attacks of red spider. Allowing the house to be open when frosts prevail is a capital means of keeping down insects. Clarke's and Gisburt Compound will also destroy the scale.

STARTING PINES (Idem).—The plants you wish to start for fruit in spring ought now to be kept dry, if for no other reason than the low temperature you are giving them; but that, with the dryness, will hasten their starting for fruit in spring. We would not place them in the cucumber house before the beginning of February, keeping them dry until then. It is likely they will fruit as you wish.

POULTRY, BEE, AND PIGEON CHRONICLE.

THIS SEASON'S MOULT.

MANY of my Dorking chickens have gone entirely through the moult, having changed, I believe, every feather. This has especially been the case with a very fine cockerel that I intended exhibiting, so that as it prevented my doing so when I wanted, I took especial notice of him, and I do not think he has a chicken's feather left. I never saw chickens in such a naked state before, and have often wondered at the cause. They have had no stimulating food for months.

I am afraid Mr. Wright's plan to stop pullets laying will be in many cases very difficult to carry out; at least, it will be so in mine, as I have only one large grass run over which all my fowls stray; therefore, I do not see how I can vary the scene; but, nevertheless, the idea seems very good, and is borne out to some extent by the very common fact of a laying hen being removed to a fresh place; in many cases this will at once stop her laying, and if the change will stop a hen laying, it is very likely to put off the laying of pullets. My plan hitherto for this purpose has been to leave off stimulating food as soon as possible after the chickens leave the hen. Of course, this must be done gradually.—T. E. KELL.

CRYSTAL PALACE POULTRY SHOW.

THIS Show was opened yesterday, and whether for numbers, or in some of the classes, for quality of the birds, must be ranked this year as one of the best, whilst in Pigeons it has eclipsed every other. The darkness of the day, and the late hour at which the awards were concluded, prevent our criticising the later classes as we could wish, but of the main classes we are able to give something like a correct description. In going through the Show we recognised many of the Birmingham competitors, and the condition in which these birds were shown reflects the highest credit both on the Birmingham and London Committees. We were also much struck with the suitability of the Palace for a poultry show, the diffused character of the light showing nearly all the classes to good advantage. In only a few was the light bad; and the very worst-placed tiers could be far better seen and judged than many ranks at Birmingham. Partly owing to this, and partly to the smaller classes, there was on the whole much more satisfaction with the judging.

DORKINGS.

1.—The cap for old Grey Dorkings was taken by Mr. Martin's well-known Rose-combed pen, combining grand size with remarkably good legs and feet. Though not yet quite at their best, these birds seem hard to beat. Second and third, good framed single-combed birds

and deserving their honours. One of the highly commended pens hardly deserved notice, and pen 7 contained a good pair of birds, but not yet through the moult.

2.—First and second prizes for cockerels were taken by same exhibitor, with fine birds in good condition, fully bearing out our remarks at Birmingham. Both in better order than at the latter show, but promise better still. Third, a tolerably-framed and very dark bird. The highly commended mostly well given, but 28 must have been meant for 29. Dorkings are decidedly not equal to former years, but this was a very fair class.

3.—First-prize pullets had large frames, but not at all matched in colour. Second contained one very fine bird, but the other much inferior. Third only middling. This class not nearly equal to the cockerels. Pen 64 contained one very fine pullet, and pen 67 appeared likely to make a good pair of hens. Several birds in this class appeared uncommonly much out for pullets, but we could not thoroughly satisfy ourselves of any deception.

4.—First-prize Silver-Greys were a medium size, but very handsome cock, with a hen of massive frame, but hardly clear enough in colour. In the second and third prizes the best cock was with the worst hen and vice versa.

5.—The cockerel class confirmed the opinion we formed at Birmingham, that this breed is advancing. The prizes were very well indeed, but pens 85 and 87 deserved mention before either of the highly commended pens.

6.—The pullets were again not equal to the cockerels, the colour appearing more difficult to breed.

7.—The first-prize White Dorkings were in truth a fine pair, both large and white. The second cock very yellow, and hen very dirty, and on the whole we preferred the third prize. The highly commended pens, except 117, struck us as very poor.

COCHINS.

8.—The old Buff Cochins were only five entries, and the third prize was deservedly withheld, only two pens being good. Cup pen a grand shaped cock, but with rather doubtful hocks, and all the tail pulled out; hen too long in the leg. Second wanting in shape.

9.—First prize a fine bird, but again all the tail gone, and rather neatly in wing. Second would also look better with more canal appendage, but in his case the deficiency appeared natural, the feather being only half grown; we liked this bird much, and were his wings quite small, and himself a month older, we question if he would not have had the honours. Third a dark bird, very promising for his age, and honestly shown. No other bird very first rate.

10.—In Buff pullets the Birmingham decisions were reversed, Lady Gwydyr's cup pen there being now put second, and first given to the Birmingham fifth-prize. We did not like the alteration, for though Lady Gwydyr's pen was as we said, anything but a match, and one bird not so even in colour as might be, they were both far better in shape than the others. Third-prize and all the rest very poor, and we repeat our remark, that the Cochins as a whole are deteriorating sadly.

11.—First-prize old Partridges very good, but nearly all the birds in this class very poorly feathered, except one bird with a suspicion of hocks.

12.—First-prize cockerel a grand shaped bird, but not quite pure in colour in under parts, and rather heavy hocks. Second not nearly equal to him, and the other birds poor.

13.—Both first and second-prize pullets good pairs, the first best in size, shape, and marking, but rather yellow. Had third been larger, we would as soon have had them as any.

14.—First-prize White Cochins a little hocked, but honestly shown, and we were glad to see them both so shown and so winning. Second well shaped and large, but the cock yellow. Two or three other fair pens highly commended with judgment, but the rest poor.

BRAMMAS.

15.—In the old Dark Brahmas the cup pen contained the first-prize Birmingham bird, whose only fault was some white in the tail, with a very middling hen. Second also had the second Birmingham cock, with a much better coloured but smaller hen in bad health. Had she been in condition it would have been hard judging. Third, a middling pen, the hen much wanting depth of colour. Pen 217, also a good pen.

16.—First-prize Dark cockerel a medium-sized bird, perfect in colour, but not standing well on his legs, and saddle rather too low. His head also struck us as coarse and heavy. Second-prize a decidedly hocked bird honestly shown, and quite as good as the first. Third, a very white-tailed bird, and full of white streaks in the buff. There were several very good highly-commended birds, but in one case (247), the commendation was a farce, the bird's hock having given way outwards, so that he could not bear his weight on one leg at all.

17.—First-prize pullets a very fine pair, third at Birmingham, and not yet at their best. Second-prize middling in colour, but very high on leg. Third, a very passable pen, one bird being really fine, and in our opinion should have been second.

18.—The cup pen of old Light Brahmas was a doubtful award. The hen was very good, but the cock had a great deal of black in his buff, and in a month will be hocked, the quills being half grown. His backle was, however, beautifully striped. Second, a good pen, but looked overdone. Third, a good pen, perhaps a little hocked, with not the slank feathering a hock should carry.

19.—The cup Light cockerel was a small but pretty bird, with long

wattles, very much the same style as the Birmingham winners. Second, a rather woody bird, cleaner, but not so good as pen 316 next door. Third-prize best striped of any in the class, but short of leg feathers. Pen 300 well deserved being added to the list of commendations.

20.—The cup pullets were very nearly perfect, whether in shape, feather, colour, or other points. Second very bare of leg-feathers; and third had faulty backles. Pens 335, 345, and 347 were all good pairs. Again the Lights showed much better than the Dark, and Light pullets were, perhaps, the best of all the Brahma classes.

SPANISH.

21.—The Spanish classes all looked much better than at Birmingham, the temperature and light appearing to suit them. Old cocks very fair and well placed. Pen 374 had a capital face, but comb gone half over. Hens also in very good order, the winner in the preceding class repeating his success with a very good pair. There were one or two pens in this class we could not understand being passed over.

22.—The cup Spanish cockerel had an immense face, but rather too coarse. Second-prize also a very wide face of better quality, and, on the whole, we preferred him to the other. The rest of the class we would not like to have the placing of. This and the pullets seemed to us the best classes in the show.

24.—The cup pullets were thought by many not deserving their honours. They were a good pair unquestionably, but either of Mr. Jones's second and third prize pairs were better in our opinion. All the birds were, however, so good that judging was hard. Miss Penman's pens came too late for competition.

FRENCH FOWLS.

25—28.—The classes for French fowls were very fair, many of the Birmingham birds competing. It appears certain now that the only varieties which can stand their ground in England are the Houdan and the Crève-Cœur.

HAMBURGHIS.

29, 30.—Golden-spangled Hamburgs were, as a class, hardly up to the mark, but the prize pens were very good. Silvers were decidedly a better class, the cup cock having a beautiful tail, which was a treat for any Hamburg fancier to see. The same may be said of pen 522.

31—33.—The Golden-pencilled were richer in marking than Silver. The light was too bad when we examined these classes to say much as to the judging, but we thought Mr. Beldon's pen 559 ought to have been in the prize list. The first-prize Blacks were a really magnificent pair, and second and third were very good, but we liked third best. This breed is advancing still year by year.

GAME.

34.—The cup Black Red Game cock had the best head and upper works generally of any in the class, and was a good specimen Game fowl. Second, a tight looking bird enough; third not quite so large, but, if anything, better style. 66 was a good bird spoilt by being too fat.

35.—First-prize hen was an only middling bird with bad carriage, the commended pen 648 being far better. Third-prize a neat gamey hen, but on the whole the second-prize was about the best in the class. Pen 637 contained also a very good hen.

36.—The first-prize Brown Red cock, a very hard bird, and well-shaped all but head, which was long and weak. Third much the same style of body, but better head. Second a middling bird. The best bird in this class (645), very unfortunately arrived too late for competition; he was almost a copy of the first-prize, but with the advantage of a perfect head, and must have headed the class but for the delay, which was owing to the railway company.

37.—The first-prize Brown Red hen was very good. Second-prize a good body, but far too red in the face. Third-prize too heavy; a little starving would improve her.

38.—Duckwings were a fair class, and all the prize birds were good. It was little more than a toss up between first and second.

39.—First-prize Duckwing hen a neat and sharp-looking bird, but on the whole we would rather have seen the second-prize in her place. Third-prize a rather large but otherwise good bird, not in her best condition. Many of the Game birds were severely trimmed.

POLISH.

40—42.—The Polish classes were fully equal to Birmingham, and again the Golden-spangled were both the most numerous and best of the lot. We were very glad to see this splendid variety again so strong in numbers and quality. The Blacks were rather poor.

MALAYS.

43.—Malays were a bare average for a separate class. Most of the birds had been at Birmingham, and appeared in rather low spirits.

ANY OTHER VARIETY.

44.—In the "Any other variety" class the first prize went to a fine pair of Black Cochins, the second to Negro Friesles (what ever will people breed mere abortions for?), and third to a very large pair of Cuckoo Cochins. The fourth prize was an error, not creditable to the discernment of the Judges, as it did not need any description in the catalogue to stamp them at once as a cross between Dorking and Dark Brahma. We much regretted not to see Mr. Tegetmeier's pen (729) of White Leghorns in place of this latter pen.

GAME BANTAMS.

45.—The cup Black Red Bantam cock was a beauty—the same

which won first in the pen at Birmingham, and with sincere satisfaction we chronicle the fact that he was shown *without* the new tail some would have put in, and that Mr. Smith gave him first prize as he was. Second a very neat been-looking bird; but third carried his wings very low, and struck us as more a Fantom than a Game bird. This class was middling, and far inferior to Birmingham.

46.—First-prize Black Red hens a really fine pair, but the second we did not like at all; the light was bad by this time, but they seemed to us very "stumpy" Beauties. Third-prize carried their wings far better.

47.—The cup Brown Red cock a Game bird, and second ditto. The third rather too heavy, perhaps, but otherwise good.

48.—First-prize hens in their place. The second we could hardly see, being in the darkest corner of the Palace, but they also seemed a pretty pen. Third fair, but we have known Mr. Crossland show far better.

49.—The first and second Duckwing cocks very good, but third much too fat.

50.—First prize in this class went to a good pair of Duckwings. The second far inferior. Third was a middling pair of Poles, to our liking not so good as another pair, but again the light was so bad we would hardly venture to quarrel with the award.

51.—In the Blacks, first was a first-class pen. The first-prize Birmingham winners were left out in the cold, and might certainly have displaced either of the others with advantage, if not the first.

52.—In this class the Judges acted on the principle, after awarding one prize, of giving the next to "Any other variety," the first going to a nice pen of Salmagundis, the second to Pheasants, third to a very middling pen of Japanese, and fourth to Whites.

SELLING CLASSES.

53-57.—The Selling classes were one of the most remarkable features of this Show, the three classes between them numbering only three less than two hundred pens! Many of the pens were of a quality that defied very good prices. In cocks, first prize went to a Bantam. In hens, the same breed carried off the honours, the second going to Partridge Cochins of very good value, and the third to a really good pair of Buffs. This last pen we thought should have been first, and had it been entered in the Buff class would have run the winners hard. In the "Husband and wife" class, variety was again studied, the first being Dorking, second White Cochins, third Sulphur, and fourth Black Red Game.

DUCKS, GEESE, TURKEYS, &c.

58-57.—We cannot give the weight of the Ducks or anything else, for the simple reason that no pens were weighed. The first Aylesburys were a good pair, but decidedly not so good as several others; neither did we much like the second. Third was very fair. In Bantams, the first was better placed, but Ducks are poultry that we think ought to be weighed.

58-59.—In Black Ducks the awards gave nothing to complain of, and all the prize pens were remarkably good. In the "Other variety" class, Mandarin and Carolinas were again conspicuous and good, and males being for a large garden that we might keep them ourselves.

60.—In the Goose class, both first and second were taken by Whites. We think had they been weighed, there was a pair of Greys would have taken at least one of these two places, but we cannot say.

61.—The first prize for Turkeys went to a pair priced at 5s. Mr. Patton's grand pen going third. Second was a good pair; but in this class again the scales were missed, probably as much by the Judges as by ourselves.

62.—The Pheasants were shown in exquisite order, and may be suggested to other shows as a most attractive feature, as far as the visitors are concerned.

63.—In the dead poultry class, Mr. Dowett's celebrated cross-bred were beaten by the Coloured Dorkings of Mr. Ellis. In Ducks, the first-named exhibitor carried off both prizes in a style which would make some hints on feeding from him most acceptable to all readers of this Journal.

As a whole the Show was a treat to inspect; but with the exception of Eight Brahmas, Spanish, and Polish, it seems to us that the birds of this season generally are not equal to those of former years. We noticed this at Birmingham, and we must confirm it now. In Cochins the falling-off is deplorable except in a very few cases both shape, size, and colour seem gone "all to pieces." Dorkings also, as a class, losing both frame and weight. Game are not so bad, a few breeders still keeping up the old standard; but the "ruck" are losing ground, getting both heavy in body and stilly in leg.

We have only to add, as will have been gathered from some of our remarks, that several excellent pens arrived too late to be noticed by the Judges. Some of the birds to our own knowledge arrived in London in time, so that the fault would appear to rest with the local line.

THE PIGEONS.

Few Pigeons were ever before exhibited in such numbers, such excellence, and under such favourable circumstances as I beheld them in the Crystal Palace this day (Tuesday). As to numbers, there were above 800 pens; as to excellence, the first fanciers in England, Scotland, and Ireland had sent their birds; and as to the position and surroundings of the Pigeons, I must ask those of my readers who know

the Crystal Palace—and I suppose those are almost all my readers—but who, unfortunately for themselves, were not present, to imagine the centre of the nave of the Palace devoted to the Pigeons, and to the Pigeons only (so far removed from the gentle Doves were the fowls, Geese, Ducks, Turkeys, &c.), 120 yards of the length of which were occupied by the pens, which were four wide. Thus, had there been but a single row, there would have been 450 yards of Pigeon pens. The majority of the cages were the Glasgow bell-shaped open-wired kind—excellent, save that each wants a sliding door for the safe handling of the birds, one of which, owing to this want, I saw escape. The rest of the cages, the square ones, had this accommodation of a door. And then, forming a very marked feature of the Show, were the large and elegant Peristeric pens, containing the collections of four pairs of birds. I must add that great care was taken of the Pigeons, and I saw members of the Committee themselves attending actively to the birds' wants. Taken altogether, the oldest fancier living had never seen such a show as was gathered beneath the central arch of the palace of glass, almost, indeed, making true the remark of an ardent fancier from the Emerald Isle, "There never was a show before." However, let us not forget former exhibitions, notably that of Glasgow in 1868.

But now for the classes. Of Pouters there were above 200 pens. This great cluster of these birds struck one forcibly at once, for in England Pouters had always before been few; but Scotland had invaded us, and an Irish Pouter (not a Fenian one), had come over; also we must remember the many articles which of late years have appeared on this noble bird. First came Blue-pied cocks. Mr. Fulton's bird, the first prize, was 7½ inches in limb, and 19½ in length. Mr. Gresham took second with a very fine showy bird. There were nineteen entries in this class. Among the eight Black-pied cocks Mr. Gresham's first was 7½ inches in limb and 20 inches in length, and flat and the other two winners were perfectly clean in thigh. The Red-pied were a mixed lot. Mr. Rose's (second-prize) I greatly admired. Yellow-pied were beautiful, and Mr. Montgomery secured two of the prizes. The White cocks, twenty-seven in number, were many of them very dirty, now a White Pouter loses half its beauty unless it is perfectly clean. The second-prize was a splendid bird. The "Any colour and marking" were true to those designations. "Mottley was their wear"—washed-out Yellows, Sandies, Mealies, Whites with a smatch of colour, Chequers, &c., but size and shape redeemed colour. Among the standard colours bred in 1870 three Blues won. The Blue-pied hen Pouters were not inferior to the cocks; the Black-pied scarcely equal. The Red-pied showed a first-prize very sound in colour; the second a fine bird, but with a white forehead. Yellow-pied, Whites, Any colour, and standards of 1870 followed.

The Black Carrier cocks were remarked on for their great excellence. The first-prize was a grand bird, showing strength and beauty combined. The first-prize hen was pretty, the second very strongly built. The Dun Carriers were fewer and not so good; the first-prize hen pleased me best. In Carriers, any colour, the prizes went to the Blues, the colour of which, to get the head good, showed much mixture with the Black birds. The Carriers bred in 1870 showed many birds of great promise.

The Almond Tumblers were, I believe, easily judged. The colour of the prize birds was extremely rich, and the first-prize among those bred in 1870 were excellent in head and beak.

The Baldheads, those birds so difficult to breed good, were but few, and save the prize birds, not good and a little large, yet there were some respectable in cut and feather.

Beards were more numerous, blue their prevailing colour, but the third prize went to fair Blacks.

Barbs—the is, old ones, were not numerous, but there were eighteen pens of those bred in 1870.

The Jacobins were very numerous, but they ran somewhat large; among them a singular and very striking looking pair entirely black—that is, head, flight, and tail black as the body. Unfortunately one was a very inferior Black, or I suppose the birds would have had a prize. Close to them was a nice pen of pure White, but not for competition.

The White Fantails were very good, but English judges still cling to tail rather than motion, for two pairs of Glasgow birds, small in size and superb in motion, were unnoticed. Blue Fantails of much excellence took a first prize.

Nuns were fewer than should have been, but the first-prize birds were super-excellent. It was gratifying to see two pens of Yellow Nuns.

The Black Trumpeters were admirable, and three pairs of the Irish brigade vanquished all opponents. It is well to remember that Trumpeters, any other colour, were not won by Mottles, as they, though grand in head and points, were too light for Mottles.

The English Owls were stronger in numbers than they have been recently, and it is well, for the Foreign Owls should not push the older favourites to the wall. Each variety has special attractions.

Turbits, Blue and Silver, were few. The Magpies were a little coarse in some specimens. Red, Yellow, and Black won in the order of the colours.

The Dragons were very numerous, and the other colours appear determined to overturn the Blue supremacy.

Tomars were large enough, and I had almost said ngly enough, to please their admirers, but the awards to this class and the Dragons had not been given when I left.

The Any other variety class, beautiful in feather and fanciful in

E. Horner; H. F. Noller; E. B. M. Boyd; J. Thompson; C. P. Fulton; T. C. Boyd; E. Schmitt.
ANY OTHER COLOURS (Any other colour).—1, W. E. Van Haasbergen; 2, E. F. M. Royd; 3, J. P. Tudor.
FANTAILS (White).—1, A. A. V. Meersch; 2 and 3, J. F. Loversidge; *hc*, W. Choyce.
FANTAILS (Any other colour).—1 and Cup, P. H. Jones; 2, H. Yardley; 3, W. Choyce; *hc*, H. Yorker.
FANS.—1 and 2, W. Banks; 3, J. Dowling; *hc*, W. E. Easton; 6, F. Williams.
TRUMPETERS (Black).—1, 2, and 3, J. Montgomery.
TRUMPETERS (Any other colour).—1, E. Hooper; 2 and 3, J. Montgomery.
CHEQUEERS (Blue).—*hc*, J. Montgomery; W. H. C. Odgers; J. Bull.
OWLS (Hulbush).—1, P. H. Jones; 2, J. Goodden; *pr*, S. J. Crawford; *hc*, S. A. V. Alice; Capt. H. Henton.
OWLS (Porten).—1 and Cup, P. H. Jones; 2, R. Hulton.
TEALERS (Blue and Silver).—1, G. H. Gregory; 2, P. H. Jones; 3, J. Dowling.
TEALERS (Any other colour).—1, Fickling; *jun*, A. A. V. Meersch; 3, P. H. Jones; *hc*, H. Yardley.
MAGPIES.—1, E. Horner (Gold); 2, H. Yardley (Yellow); 3, P. H. Jones (Black); *hc*, E. Horner.
DRAGONS (Blue or Silver).—Cup, 1 and 2, J. Holland; 3, W. R. Tegelmeier; *hc*, J. Holland.
DRAGONS (Any other colour).—Cup, 1, 2, and *hc*, S. C. Betty; 3, J. Watts (White).
ANY OTHER VARIETY (Short-faced).—1, J. W. Bradley; 2 and 3, H. R. Wright; *hc*, E. Horner; H. F. Wray; J. A. Colburn.
BUNTS.—1, Lady E. Buxby; 2, P. H. Jones; 3, S. A. Wyllie; *hc*, T. D. Gray; H. Yardley.
ANY OTHER VARIETY.—1, J. Wallace; 3, W. F. Tegelmeier (Ice Pigeons); 4, E. Horner; *hc*, Rev. A. G. Brooke (Mottled); W. B. Tegelmeier (Flour-bush); J. Wallace; P. H. Jones.
SELLING CLASS.—1 and 2, J. Ford (Almond Tumbler); 3, H. J. Dwelly (Swiss Tush); 4, J. Guthrie (Almond Tumbler); *hc*, H. Brown; T. Chavry (Blue Dragon); J. Ford (Dragon); J. A. Greenhall; H. Gellert; G. H. Gregory (White Foulback); Hon. Mrs. Paget; G. Hooper; W. B. Tegelmeier; S. A. Wyllie;—Thompson; C. W. Price; *jun*.
BEST COLLECTION OF FOUR PAIRS (Exclusive of Carriers, Pouters, and Tumblers).—Cup and 1, W. Banks; 2, P. H. Jones; 3, B. Fulton.
BEST COLLECTION OF FOUR PAIRS OF SIMILAR TUMBLERS (Distinct Varieties).—1, 2, and 3, J. Ford (pair Black Tumblers, pair Blue Tumblers, pair Red Tumblers, and pair Yellow Tumblers).
BEST PAIR OF SIX WINGED SINGLES.—1, J. J. Sparrow (Blue Chequer); 2, W. Lund (Red Chequer); 3, J. Crawford (Red Chequer); *hc*, G. Grinsell; G. Mathewson; C. L. Sutherland; T. Cook.
POULTRY.—*Poultry*: Mr. E. H. Witt, Mr. R. Tealy, and Mr. J. H. Smith. *Pigeons*: Mr. E. Esquillant, Mr. Jones Percival, and Mr. E. Corker.

THE PIGEONS AT THE BIRMINGHAM SHOW.

(Extracted from Notes by Members of the Birmingham Columbarian Society.)

We regret to see so great a falling-off in the entries, and it would have been more conspicuous but for the spirited entries in the Antwerp classes—a result due to the liberality of the Committee and the Birmingham Columbarian Society. The management was good, as evidenced by not a bird dying, and we know the majority of the birds went home in as good condition as they left it. We should like to see all the pens supplied with the tin water vessels, and think a little dry red sand mixed with that now used would keep the pens drier, and pleasanter to look at.

TUMBLERS.—The post of honour was, as usual, held by the *Almonds*, who were represented by eight entries of far more than average merit. The first-prize pair in colour were superb, the hen as rich as the cock. We have seen a finer beak and wattle than the cock carried, and cleaner, better than the hen's eye or lash. The second-prize pair were not so good a match as the first, the cock again rather coarse in beak and wattle. Of the third-prize birds the cock, like the first-prize hen, was blotchy in the eye.

In the class for *Balds* and *Beards* the first-prize pen were a pair of Blue Beards; good match and colour. The second-prize birds were a pair of Yellow Balds, a nice pair. The third-prize takers were Beards. Mr. Fulton was highly commended with a pair of Black Balds, that would have looked much better of a little oil. In the *Short-face* class the first were a pair of Black Mottles, that wanted a little less or more oil.

We were pleased to see a class for *Muffed Tumblers*, but greatly disappointed that it was so meanly supported, as we know the town has a number of fanciers of the Muffed birds, and we expected them to support the first class made for them, for if well supported it would be an attractive class. The first-prize birds were a pair of Red Rose-wings, and the second a pair of Black Mottles.

We were still more surprised that the class for *Glean-logs' Tumblers* was no better supported, a bird that nearly all understand and would take an interest in. We can only account for it by their having been so long neglected by show committees, and their owners now not being generally aware of the honour conferred upon them.

ANY OTHERS.—Since it was admitted into the competitive lists of public shows, this class of Pigeons has attained such popularity as to be regarded as an important auxiliary to Pigeon exhibitions. More especially is this the case at Birmingham, where they are bred in great numbers, and the Council of Bingley Hall Show agreed to the subdivision of the Antwerps into four classes—Silver Duns, Blue Duns, Red Chequers, and Blue Chequers.

The success of the experiment will be best shown by the number of entries, which amounted to sixty-one—viz., Silver Duns twenty-three, Blue thirteen, Red Chequers fourteen, Blue Chequers eleven. The classes were well represented by good birds, though there is room yet for great improvement, which we hope, by careful breeding, will soon be achieved. In several cases the awards were not in accordance with general opinion; we believe that in one or two instances higher qualities were thrown aside, simply on account of colours not matching

exactly; this was especially the case in *Silver Duns*, in which class every other point of excellence was sacrificed—as an instance, the best pair in the whole of the classes shown by Mr. Wright, which possessed all the required properties of standard birds. Mr. Yardley's best pair shared the same fate. It is strange, after the judgment of the Silver Dun class, to find that colour was disregarded altogether in the case of the *Blues*. The hen bird of the pair which gained the first prize was darker than its mate, and its head was flat—a thing unpardonable in a show bird. Why the cup was given to this pair we cannot conjecture, when we see a pair of birds in the *Red Chequer* class, though only gaining a second prize, vastly superior. The *Blue Chequers* were skilfully judged, as the most meritorious birds received the awards, and the whole deserved praise.

CARRIERS.—The highly commended *Black* cock bird of Mr. Siddons we think was far superior to either of the prizetakers. This class was not well judged. The prize Black hens had been artistically trimmed; they ought to have been disqualified. The best Black hen (No. 2151) was passed over, though good in all points and honestly shown. All the specimens were sadly deficient in colour, the Carriers, as a rule, being inferior to what have been seen in Bingley Hall for some years.

POUTERS.—The *Red* cocks were a very inferior class, with only six entries. The hens were also a poor class of five entries only. The Pouters had ten classes apportioned to them, and £30 prize money for seventy-two entries. Unless fanciers help the committee they must expect these classes cut down. When the Whites were taken out and the first-prize birds in the other classes, a more meagre lot never appeared at any show.

REDS.—Only five entries to compete for £3 prize money and a silver cup, value £5, generously given by Mr. Green, which was won by Mr. Yardley with birds weighing 1 lbs. 6 ozs., Mr. Jones being second. Feather in this variety ought to be taken into consideration, so as to make it attractive, as well as mere weight. The winning birds were ill matched; such will always be the case as long as the scales have to decide.

JACOONS.—In *Red or Yellow* Mr. Fulton was first with a pair of Yellows bad in colour; the cock very coarse in every point. The hen's hood was completely broken—scarcely a feather left in the hood. The same gentleman was second with a pair of Reds—coarse; the cock foul-flighted and very long in feather, anything but good birds. Both these pairs of birds had been well greased either by accident or design.

In the class for *Any other colour*, of Mr. Van Haasbergen's pair of Blacks the hen was good; the cock was very coarse, open-frilled, no hood, and cut very low the same as a Bald. Mr. Royd's should have been second with pen 2294, a good pair of Blacks well matched. Mr. Percival also showed a good pair of Whites, with pearl eyes, in splendid condition, and fully deserving a high commendation.

FANTAILS.—In *Whites* Mr. Choyce was second with a pair of birds of good carriage, the tails having the centre feathers broken, which permitted their head to project through them. This was a good class, numbering twenty pens.

TRUMPETERS.—In *Mottled* Mr. Horner obtained both prizes. The first prize pair had good caps, rose, and muffs, with no mottle on the wing; had it not been for a few spangles on the head they would have had to compete in the "Any other colour" class. So long as this class is for "Mottled" birds ought to be mottled, or be disqualified. The second-prize pair were good, with the exception of white feathers in their flights. Mr. Erth's highly commended pair was decidedly the best in the class, though deficient in colour.

OWLS, ENGLISH.—Mr. Page was first with a very good pair of Whites, the same birds that obtained this position last year. Mr. Careless was second with a pair of Silvers, the best birds in this class. Had the owner done a little "weeding" he would have obtained the first prize, there being a small white feather on the face not larger than a pin's head. The Judges themselves acknowledged had this been drawn the position of the birds would have been reversed—encouraging this, for an honest exhibitor.

BUNTS.—At a future show it will be admissible to class Black and Dun together, so as to give the Yellows and Reds a chance, as the Duns are nearer perfection than either Yellow or Red.

BLUE DRAGONS.—The whole class was highly commended by the Judges. With this we cannot agree, as many of the birds were coarse, far too coarse to be admitted as Dragons.

ANY OTHER NEW OR DISTINCT VARIETY.—Mr. Banks was first with a pair of birds recently imported into England by the Secretary of the Birmingham Columbarian Society. They are dark-headed, tufted, and well frilled, very short in bill and head; every feather is spangled on their body; each flight feather has a spot of white on the end about the size of a sixpence; dark tails, with spots on each feather the size of a shilling, and grouse-muffed. These well deserved the award. The Rev. A. G. Brooke was equal first with a pair of Norwegians; Mr. Ailsop second with a pair of Damascenes, imported at the same time as Mr. Banks's. These were a good and well-matched pair of birds, of a light powdered blue colour, with distinct black bars, short in bill, and round-headed, the lash round the eye of a deep blue colour. Mr. Paget was equal second with a pair of Scandaroons, a variety of bird that possesses no particular merit, being large and coarse. Mr. Paget also obtained both third prizes with a good pair of Satinettes and a pair of Blunettes. These are good, and deserve a higher place. They are a blue-sided bird with a pink bar, every feather of which is edged with black, a blue tail with spots the same

as in the *Satinette*, the remainder of the body white; a good frill, and grouse-muffed. If this bird could be bred as short in bill and as round in head as the *Satinette*, nothing could surpass it. Swifts were highly commended. Mr. Watts and Mr. Banks also showed birds that were worthy of a prize, and were supported with the aforementioned varieties; they were good in feather and pencilling, and will be heard of at a future day. This was a remarkably good and strong class, numbering twenty-three pens.

BRECON SHOW.

Will you allow me to ask through your columns if any of the prizes awarded at the Brecon Show, on September 21st and 22nd, have been paid? I have not received the sum to which I am entitled, and on writing to the Secretary got no reply.—A CONSTANT READER.

[Give the Secretary notice that if payment be not made by a day you name, you will sue him in the County Court.—Eos.]

BALDHEADS AND BEARDS.

I THINK it is high time my cooing should be heard, for I consider I am a neglected bird, and have quite as much right to be seen and admired at shows as other Saut-faced Tumblers. Nine out of ten prize lists do not contain a class for me. I think the number of entries at the Palace Show affords a clear proof that a separate class for Baldheads and Beards will pay.—AN OLD BEARD.

FOUL BROOD.

ABOUT this time last year I sent you an account of the successful introduction of six Ligurian queens into as many stocks of black bees (in Ireland), and looked forward to being able to report a favourable return for the trouble this season. So far from this, however, if I would "a tale unfold," it must be one of unmitigated disaster; and as the misfortune of our neighbours will generally convey a lesson, if rightly viewed, I am induced to send you the following account of my apianian troubles.

It may be, and I think probably is, the case, that some of your bee-keeping readers are in the same unconscious state of blissful ignorance in which I have been in; and whilst reading plenty about the horribly infectious foul brood, and even seeing their stocks dying unaccountably before their eyes, never for an instant suspect that they have the contagion in full force in their own apiary. As my experience may put such as these on their guard, and lead them to a careful examination of their stocks, or may somewhat interest your more fortunate bee-keeping readers, you may, perhaps, think it worth a place in your columns.

At the fall of the season of 1869 my apiary boasted of ten stocks—viz., the six black ones with Italian queens (mentioned above), two pure Ligurian stocks, and two hives of black bees, with queens of the same colour. All were strong with good stores of honey, and although, when examining the six stocks to find the black queens, I saw through all patches of dead brood, these did not attract any special attention. I made all up snug for the winter, well satisfied as to the state of my colonies, and with bright anticipations of a fine return from the next honey season.

March of the present year was fine and mild, and the bees began to show outside early; the black stocks in the smallest numbers, the pure Italians much stronger, and the Ligurianised ones sending out a goodly number, among which a large proportion were well marked Italians. By the middle of April a complete examination was thought advisable, resulting, much to my disgust, in the discovery that the two black stocks were dead, not a bee being found alive in them, but there were large stores of honey; most of the other hives were very weak, while a few were tolerably strong, but none in the condition that their strength in the fall and the so far favourable season would have led one to anticipate. At last the dark suspicion forced itself on my mind, that for two seasons I had been nursing the dreaded foul brood, and by every possible means spreading it through my apiary. A piece of brood comb sent to Mr. Woodbury elicited an opinion that but too strongly confirmed my worst fears, which all the valuable information in your Journal had before failed to arouse. Many things before so mysterious were made at once clear, and the cause of the devastating influences which had in 1868 reduced the number of stocks from eighteen to ten, and again in 1869 still further reduced the toll, was apparent.

However, I resolved on trying Dr. Preuss's system of cure,

and having laid in a stock of new hives, frames, and bottom-boards, with a supply of carbolic acid and lime, I set to work to try to get rid of the plague off-hand. Every colony was diseased, so going through them all I changed the hives (soaking them, as taken away, with carbolic acid), cutting out all the diseased brood I could find, washing each frame with carbolic acid, and laying down lime in front of the stands. In ten days I had to repeat these operations, the stocks being as bad as if I had done nothing, and at this time I also found two of the hives queenless, and so weak that I had to join them to two others in order to save the remaining bees. Ten days later being in no better condition, and finding the season slipping over without any result being obtained, I decided to resort to the more vigorous measures recommended by Mr. Woodbury; and fresh hives, &c., being again procured, I brushed all the bees into them, and left them to begin the world again.*

An inspection in another fortnight showed me that once more the plague was doing its work, and two more of the stocks were queenless. This left me but four stocks, as the last two I also added to others.

Finding now the powerful enemy I had to contend against, I gave up almost all hope of saving any of my stocks, and turned my thoughts to the preservation of the Ligurian queens. Two black stocks were therefore purchased in old-fashioned straw hives, and placed in position about two miles from my original apiary, and having driven them I fixed the combs in frame hives, and transferred the bees into them. A few days afterwards I took the black queens out of these hives, and introduced the Ligurian queens from two of my original, and now diseased stocks, leaving them to raise new queens, which they soon did. By constant examination, and cutting out every foul cell as it appeared, I was able to strengthen the four infected colonies, but not to get rid of the disease. At the end of September I obtained two more stocks in straw hives, and doing the same as before with the combs and bees, I exchanged their queens for the two raised in the Ligurian hives.

I was now in possession of four Ligurian stocks in good health, and four diseased ones; of these I have since moved two to another part of the country, and having purchased a quantity of honey in the comb, have fitted up new frame hives with it, and transferred the bees into the hives so furnished. The one longest done is now working well as far as the weather permits, and when last examined seemed free from disease.

The other is only recently done, so I cannot say how it will turn out, but if it succeed we purpose doing the same with the remaining two infected hives, and so leaving the original apianian site without a stock, so to continue for some time. This is, I believe, the next best thing to burning the diseased stocks and all belonging to them in the first instance, which is, after all, I am convinced, the cheapest thing to do wherever this disease gains any way in an apiary. Had we done so when we became aware of its existence in our stocks, we should have been saved an immensity of care and anxiety, and would be now fully as well off as we are.

I think you will admit that few apianians would take anything like the same trouble that I have done (nor indeed would I advise them to do so, when the disease has obtained full possession of most of the stocks, as in my case), yet you see that all the results I have to show are two stocks saved (if saved at all) at the very end of the season, and at the expense of an entire new outfit and fresh combs of honey.—HIBERNIAN BEE.

* You appear to have omitted the three or four days "penal discipline and banishment," in an infested hive, which is a most essential feature in the only mode of treatment which I found at all efficacious in curing foul brood.—A DEVONSHIRE BEE-KEEPER.

OUR LETTER BOX.

FOWLS DYING.—FEEDING (E. P.).—The purple comb, loss of appetite, moping, and then dying, indicate poison, and I write thirty die off we should be disposed to attribute the destruction to that cause. Your feeding is very bad; it is good enough to keep your fowls alive, but not in good condition. The only good food you give is the crushed barley, and you qualify that with bran. Give at daybreak a feed of half-peas or of ground oats slaked. Give table and house scraps and whole corn at mid-day, and again in the evening. Eaten potatoes, Indian corn, and bran. If you have another foul attack I give immediately three pills of camphor each the size of a pea, and about a table-spoonful of brandy and water, half and half. We have known this very successful in restoring a condition, and shall be glad to hear the result in your case.

HENS GOING TO THE NEST, BUT NO EGGS (Eggs).—There is mis-

management somewhere. We believe your fowls laid and ate their eggs. The Brahmas are not only good layers, but they are useful fowls in every way. Fourths flour and bran, and Indian meal, are all bad food. Feed as we have advised "E. P." above. Watch your fowls, or let them be watched when they go to nest, and do not give them the opportunity of eating the eggs they have laid. If they continue to lay soft eggs it is because their secretions are at fault, and we attribute it principally to their food. We have no doubt more attention to that point will remove all cause for complaint.

COCHIN-CHINAS (I. B.).—Your first case is not a disqualification, but it is a disadvantage. In the second case we should send the finer bird.

DARK COLOURED DORKINGS (M. B. D.).—There is so much difficulty in breeding the Silver-Grey Dorkings, that we advise you to adopt the "Dark Dorking." You will occasionally breed Silver-Greys from Dark, and Dark from Silver-Greys. From the mixture of colour you mention you will breed handsome birds partaking of the feather of both parents, but the probability is you will not breed either pure. You will not injure your dark birds by mixing them with light, but you would spoil your light by mixing with dark. As you say your fowls are for family uses, we advise you to breed perfectly pure Dorkings without troubling yourself about colour. The only work entirely devoted to Dorkings was one published some years ago by Baily, and called "The Dorking Fowl." It is now only to be had bound up with the rest of his work on poultry.

CHICKENS NOT TRUE IN COLOUR (E. D.).—You must choose your Brahma breeders next year without a suspicion of brown. The chestnut patch on the wing of the cock is often seen, but it is not desirable. We do not think the Light Brahmas breed more truly than the Dark. Both are subject to the difficulties and disappointments that belong to all breeding to feather. The best of every breed are the sexerest and the most difficult to breed. Your buff shade is a disappointment to you, and a disadvantage at a show. It is not a disqualification.

RUÉ AS A MEDICINE (Barkhamstead).—Rué is a very old-fashioned poultry medicine. It is given chopped fine and mixed with butter. Embryo eggs can always be found in a hen from the time she begins to lay till she is past it. When in full laying they are more developed, and show the order in which they will be laid.

EXPERTISE BRAHMAS (Worcester).—It is not usual to wash the feathers on the legs of a Brahma cock, but there is no difficulty in doing it. Take some warm water, and for white feathers some soap, rub the dirty feathers with a piece of flannel and dry before a fire or in a basket of clean soft straw. As only the outer and exposed part of the feather is dirty, you must be careful to see only that part, and the cleansing must be done by wiping the feather down. If this plucking be hurried and wetted you will have done harm rather than good. If the Brahma price was justified at a small show, either the bird had lost condition or the judges were at fault.

BRAHMAS (H. C.).—Your Dark Brahma weighs well (9) lbs. at seven months old, and may be exhibited with good hope of success. Your Light Brahma with a single comb is worthless to breed from, as he would be sure to disappoint you. So far from breeding from a party-feathered cock to improve any black breed, the difficulty is to breed cocks without foul feathers. Buy a cock and two or three hens of the best you can get, and cross them with your own. A Spanish bird often helps, but it requires a good deal of comb-comb line-bone-out.

BLACK BIRD GAME FOWLS (Sub-criber, Teol-in).—Wherever all the points of a breed are required, we, with all good feeling, advise our readers to buy one of the many books published on the subject. Our hints will not permit us to repeat. One essential in a Black Red Game cock is a thoroughly black bill and feet, any white is a defect. The hens should be brown all over; they may have wheaten breasts, and must have yellow striped hackles. All preceding in and in is in our opinion injurious. We prefer breeding from hens with young cocks to young hens or pullets with an older mate. The Cambridge Turkey should be spangled all over. The cocks may be kept three seasons, and one bird will be enough for twenty, thirty, or more hens. It is usual to run three Geese with a gander. Build n Geese are average breeders, but not so prolific as the Toulouse.

FEEDING TO INCREASE WEIGHT (G. M.).—Your food is not good enough for hens to attain up weight at this season of the year. In your morning feed put in parings and soil of the road. In your afternoon feed you will get more that will do well on bread and barley-mixed. Bran is absorbed by fowls. They do not assimilate, they are obliged to swallow it whole; if they do and imbibe flesh, and they drink too much, they will have the kitchen scraps and the Potato parings and the rice. Let them have them in a shed with hay-mat. At midday give them whole barley and in the afternoon dry. In the evening feed as in the morning. If there be not enough of the kitchen scraps to make two or three meals, divide the quantity equally. It is of no use to give oats to fowls. Ground oats are the best food, and barley-mat the next best.

BRAHMA COCKS REELING IN HIS FEATHERS (T. A. D.).—Your bird is heated, but if all your birds are heated alike, and thus only loses its feathers, it cannot be the result of their food. The skin is so heated that the feathers are not fed, and the root itches; this causes the bird to pull them out. The cure is to purge freely with castor oil—a table-spoonful every day, to give lettuce freely, and to follow up with Baily's pills. If you must catch the bird, and keep him quiet, till he be cured, and it will not be long.

POULTRY FEEDER (I. T. G.).—The feeder you mention is called a "hopper." The bird jumps on to a table, which, falling with the weight of the bird, opens the box that contains the food. It is made by Baily and Son, Mount Street, and is very durable and inexpensive. We do not think such feeders good for poultry, as the exact theory is that fowls should not eat more than what at a time, but pick it up grain by grain, with blades of grass, chopped weeds, small stones, and many other things good for health, and necessary for digestion. The plan we adopt is to give in the corn, which is too large for small birds. We have many, but not enough for a mouse, till the bird weathers it in.

PULLETS AND CARRIERS (Sub-criber).—If you only need eggs, the carrier need not be kept.

CARRIER'S HEAD (G. G.).—The head of a prize Carrier Pigeon must be long, narrow, and flat, the top having a slight depression in the centre. Length, narrowness, and flatness, are the great points in the head; if it be round, it is called barrel-headed, which is a great fault. Length of

skull and beak should be, in a cock, 2½ inches, in a hen 2 inches. The width of the skull should not exceed half an inch, measured at the back of the head behind the eye-wattle.

DRESSING RABBIT SKINS.—Wellwisher has sent us the following in answer to a query from another correspondent—"Rabbits' skins may be cured so as to remain soft and pliable, by the following method:—Soak them for a short time in water, and then, if they require it, trim them on the inside by scraping. Then place them for three or four days in a bath made by mixing 2 lbs. of bran in a gallon of water. Next a paste made with 1 lb. of alum, and 3 ozs. of common salt, moistened with water and worked together, is spread on the inside of the skin and left for about eighteen hours. Then hang up the skins to dry, with the fleece or hair outermost, and, if possible, in the sun. After this smooth the inside with pumice-stone, then stretch or brush the outside."

CENTRIFUGAL HONEY-EXTRACTING MACHINE.—"Have any of your readers tried the above-named machine? If so, with what result? Is it easy to make from the directions given in 'our Journal?' and is it efficient?"—J. R. J.

PERRY.—"I. B." wishes to know how to manage perry so that it will be sparkling in the bottle.

METEOROLOGICAL OBSERVATIONS

In the Suburbs of London for the week ending December 6th.

Table with columns: DATE, BAROMETER (Max, Min), THERMOMETER (Air: Max, Min; Earth: 1 ft, 2 ft), Wind, Rain. Rows include Wed., Thurs., Fri., Sat., Sun., Mon., Tues., and Mean.

- 31.—Clear and fine; densely overcast; cloudy and cold.
1.—Fine and frosty; overcast; cold wind, overcast.
2.—Densely overcast; overcast; fine, frosty air.
3.—Sharp frost; overcast, slight rain; densely overcast.
4.—Clear and frosty; cloudy and cold; fine, frosty.
5.—Sharp frost; densely overcast; overcast.
6.—Drizzling rain; rain; heavy rain.

COVENT GARDEN MARKET.—DECEMBER 7.

The markets generally are supplied in excess of the demand, and many stands remain uncleared at lower prices, any improvement upon which must not be expected for a week or two. The first season afforded an abundant crop, and the imports of fruit continue heavy, and good prices can only be obtained for choice parcels. The Potato trade is somewhat better, choice Regents bringing 70s. to 8's. per ton.

FRUIT.

Table listing various fruits and their prices, including Apples, Cherries, Chestnuts, Currants, Blackberries, Raspberries, Strawberries, and Walnuts.

VEGETABLES.

Table listing various vegetables and their prices, including Asparagus, Beans, Broad, Cabbages, Carrots, Cauliflowers, Celery, Cucumbers, Endives, Kidney, Lettuce, Mushrooms, Onions, Parsnips, Peas, Potatoes, Radishes, Rhubarb, Spinach, Tomatoes, Turnips, and Vegetable Marrows.

POULTRY MARKET.—DECEMBER 7.

The cold weather and the approach of Christmas have somewhat improved the tone of the market in all but Game.

Table listing various poultry and their prices, including Linnets, Small ditto, Cuckoos, Ducks, Hens, Pheasants, Pigeons, Rabbits, Wild ditto, Hares, Partridges, and Grouse.

WEEKLY CALENDAR.

Day of Month		Day of Week	DECEMBER 15—21, 1870.			Average Tempera- ture near London.			Rain in last 43 years.		Sun Rises.		Sun Sets.		Moon Rises.		Moon Sets.		Moon's Age.	Clock after Sun.	Day of Year.
			Day.	Night.	Mean.	Days.	m.	h.	m.	h.	m.	h.	m.	h.	Days.	m.	s.				
15	Th	Meeting of Linnean Society, 8 P.M.	47.9	33.6	40.3	19	1	41 8	4	41 8	43	41 11	53	41 0	0	4	39	349			
16	F	Cambridge Michaelmas Term ends.	46.5	32.9	39.7	15	2	8 48	2	48 2	4	48 2	54	48 0	23	4	9	359			
17	S	Oxford Michaelmas Term ends.	45.9	34.0	39.9	29	3	8 49	3	49 3	0	1 14	1	14 1	24	3	40	351			
18	SUN	4 Sunday in Advent.	45.8	33.7	39.7	20	4	8 50	3	50 3	22	2 37	1	37 1	25	3	11	352			
19	M	Length of Day 7h. 15m.	45.4	32.5	39.5	16	5	8 51	3	51 3	44	3 1	2	1 2	26	2	41	353			
20	Tr		44.1	33.6	38.9	18	5	8 50	3	50 3	10	5 31	2	31 2	27	2	11	354			
21	W	Shortest Day.	44.1	34.9	39.0	17	6	8 51	3	51 3	35	6 19	3	19 3	28	1	41	355			

From observations taken near London during the last forty-three years, the average day temperature of the week is 55.4°, and its night temperature 33.7°. The greatest heat was 59°, on the 15th, 1868; and the lowest, cold 7°, on the 16th, 1853. The greatest fall of rain was 0.87 inch.

THE EVERGREEN OAK.



SINCE the rage for Pinuses has set in with so much ardour, it is to be feared that many of our choice evergreens have been neglected, and orders sent to nurserymen for Phillyreas, Alaternus, Arbutus, and the like are so limited that it is not unlikely some of these trees and shrubs will by-and-by be regarded as rare. There is also another tree deserving to be more frequently planted than it is, and that is the Evergreen Oak; for although old gar-

dens and grounds present us with many fine examples of this tree, it is seldom met with in a young state. It seems to have somehow lost favour with the working gardener, for it sheds its leaves at a time when the garden is expected to put on its best garb, and a tree of this kind on the lawn causes a continual sweeping-up of leaves for about two months of the busiest part of summer. Another cause of disfavour is the small number of subjects that promise to become well-shaped trees, most of them taking the shrub or bush form. The latter evil is a difficult one to prevent, for it occurs in plants raised from seed as well as in those from cuttings and layers. To these drawbacks another important one may be added—the Evergreen Oak transplants badly, being in this respect, perhaps, the very worst tree we have to deal with. These united evils no doubt exercise their influence on planters, and lessen the number of trees planted. On the other hand, the fine examples occasionally met with excite a feeling of another kind, and the wish is expressed to have as fine a specimen as that which has been seen.

In reference, therefore, to the planting of this tree, I believe the most successful results have been accomplished by planting in May, and even at the end of that month, but I only give this advice on the authority of a friend, as I have not personally transplanted at that time. Young trees are also recommended. If the weather is dry and bright, some shading is desirable for a few days, and a shower of rain will work wonders: by the end of summer the tree will have assumed its proper costume, and all will go on well. If I had a plantation of this tree to make in the autumn, I would be disposed to adopt the most primitive mode of all, and that would be to put in the acorn where the tree was to grow, and if the soil and subsoil were all right, I would leave the rest in a great measure to Nature.

I must here state what I have already said in other places—that I am no enemy to tap roots of any kind, excepting as regards some fruit trees, and I am not sure they are injurious to the latter: but with respect to all deciduous forest trees, Pinuses, shrubs, and the like, I have first to learn the harm such roots do ere I condemn them. On the other hand, there can be no question of their utility, or Nature would not furnish them: they give the tree a sort of anchorage in the ground, so necessary for resisting the winds, and we may rest pretty well assured that tap roots are only formed on such trees as want them. We must consequently act directly at variance with

Nature's laws if we remove roots so necessary to the tree or shrub: therefore, by sowing the seed where the plant has to grow, every facility is given to its roots extending in any direction which may be most beneficial. I have a shrewd guess that in half a dozen years a plant so reared will be larger than one transplanted at the same time as the seed was sown, providing fair treatment be accorded in both cases, and the healthy vigorous appearance of the young seedling would be much in its favour: and possibly some interest might attach to it by some juvenile member of the family putting the seed in the ground, and in after life being able to point out a large fine tree that he remembered sowing. The Evergreen Oak affords as good a memento as anything, and from the appearance of old specimens, seems likely to retain its vitality for a much longer period than many Pinuses.

Having in some degree described the mode by which ill success in planting may be easily prevented, for seed is plentiful enough, I will next take in hand the more difficult problem of inducing shrub looking plants to become trees. Here, it must be confessed, a great departure from Nature must be made, and the knife and stake put in requisition, but they may be used with better hopes of success on this tree than on many others, for I do not know of anything deciduous or evergreen that bears a severe pruning with less injury than the Evergreen Oak: even trees of large size may be half-cut away without injury when it is necessary to improve their shape, and they speedily feather out and recover a furnished appearance on the side which has been cut. Trees of 30 feet high, or more, and provided with three or four leaders, may have them reduced to one with a good prospect of that doing well; and whatever beauty there may be in a fine spreading head, there is more when that head emanates from a bole of some length. In all cases, therefore, I would advise a certain amount of clear stem if it can be had, and in most instances this can be secured by timely and judicious pruning: or should this happen to have been neglected till late, even then, as stated above, the tree, if healthy, will endure it with less injury than most others of a like kind.

Fine specimens of Evergreen Oaks are often met with. Witness the fine trees about Fulham. One in the nursery of the Messrs. Osborn, where there are also several remarkable trees, is very fine, as are also some others in the same neighbourhood: while one of the finest I ever saw was in the grounds of Yotes Court, the seat of Lord Torrington, in Kent. This tree, however, scarcely showed any stem, but had a fine spreading head of upwards of 80 feet in diameter, exhibiting foliage of the deepest green. Differing from this in everything excepting vigorous health was one I met with not many days ago in the grounds at Barham Court, a fine old place, where there are other remarkable trees, including many of recent introduction, the present proprietor, R. Leigh, Esq., having directed much attention to them. The Oak referred to is more upright than usual, there being a clear bole of 10 or 12 feet without a branch, and the girth of this bole at about 5 feet from the ground, where the stem is as smooth

almost as a ship-mast, is 10 feet. The height I could not ascertain, but it equalled that of some neighbouring Limes and other trees, and, standing in front of them, the fine green foliage offered a strong contrast to the autumn tints these trees had assumed.

While on this subject I may mention that at the same place, Mr. Ewing, the able gardener, pointed out to me a Willow-leaved Oak of the deciduous kind that seemed to be growing as quickly as the common one generally does. I did not ascertain how long it had been planted, but its fine straight stem surmounted by a vigorous head, having a sort of elliptical outline, indicated that at a period not long distant it would be a fine tree. As it was, the girth of the bole at about 5 feet from the ground was 5 feet 8 inches—a good size for a tree that, I believe, has not been so very long known to cultivators. The soil, I may add, was good, overlying the Kentish rag and its accompaniments—a soil in general favourable to the growth of trees of most kinds, and shrubs also, the Rhododendron and its congeners alone excepted.—J. Robson.

GOOD AND BAD STOKING.

It is curious, but none the less true, that the influence of the stoker on the economy of fuel is systematically neglected by engineers. In estimating the relative merits of different engines, it is always assumed that the fuel is burned under conditions with which the men who supply coal to the furnaces have nothing whatever to do—in short, that any man who can throw coals on a fire and keep his bars clean must be as good as any other man who can do, apparently, the same thing, and, apparently, nothing more. But it is certain that this conclusion is totally erroneous. The steam engine has been so far improved that it is only by the utmost refinement of skill that small economies can be effected in the consumption of fuel; and the brains of the best men of the day are taxed to the utmost to design these refinements, and apply them properly to their intended purpose. But all the while the influence of the skill of the stoker is overlooked, and, at the same time that we are moving heaven and earth to save an ounce of coal per horse per hour, we employ men without question who may waste through ignorance ten times as much fuel as we try to save, or neglect men who might save ten times as much by their skill as the engineer can hope to save by his. This matter was never brought into a clear light until the recent engine trials at Oxford, when for the first time the judges measured the water evaporated. The results were startling in the extreme. Frederick Moody, one of the best firemen in England, succeeded in obtaining an evaporation of 1.87 lbs. of water per pound of coal from the society's boiler, the Reading Ironworks Company's engine running for three hours nineteen minutes. Messrs. Marshall's man got from the same boiler, and with the same coal, an evaporation of only 8 lbs. of water per pound of coal. Messrs. Marshall's engine ran but two hours forty-four minutes, and consumed 5.18 lbs. of coal per horse per hour. If Moody had fired for Messrs. Marshall with as much skill as he fired for the Reading Iron Company, the consumption of fuel would have been but 1.22 lbs. We thus find that a difference in the skill of two stokers, both very good—Messrs. Marshall's man was far above the average of stokers—may cause a difference of nearly a pound of coal per horse per hour in the relative consumption of two very good engines. Surely it is time to think of the stoker when we find that he can save or waste 20 per cent. of the whole weight of fuel required to do a given amount of work. We have gone on improving boilers and engines for years—suppose that, just for a change, we try to improve the stoker.

In conclusion, we may point out that the anomalous results obtained from boilers of the same type under different circumstances are probably due to varying skill on the part of the stokers. No trial can in future be considered satisfactory which does not take this consideration into account.—(*Engineer.*)

We fear that if the word gardener were substituted for engineer it would be easy to find more fault with the mode in which gardening stoking of furnaces is too generally conducted. Even the most simple considerations are frequently neglected, and what ought to be a matter of thought becomes too often a mere matter of course.

The following precautions will never be neglected by a good furnace man. Before a fire is put on or mended for a hot-house the sky will be scanned, so as to form an idea whether the air is likely to remain as it is, or to become warmer or colder. The wind of the day is then to be consulted, and

note taken as to whether the mercury is rising or falling. The inside thermometer should next be examined, and its rise or fall noted; and then where a fire has been burning the heating medium, be it stove, flue, or hot-water pipe, should be felt by the bare hand, so as to be sure of the heat there, and thence, from practice, the stoker forms an idea of how that heat is likely to influence the confined air in the house. All these little matters will be attended to, as a mere necessity, by every good fireman before he goes to the furnace. Are they attended to as they ought to be? Is it not too common for a man to jump down into the stokehole and pile on the fuel? And if these little matters are attended to at all, it is after the fire is all right and blazing away with a vengeance, and sending the greater part of the heat, in the case of a boiler, up the chimney. Need we wonder that houses become too cold at night, or too warm in a morning, or the contrary? that when there is too much heat the furnace doors are left open, with the attendant waste? that dampers might as well be a thing unknown for the use that is made of them? or that in a cold morning fuel is piled on quite regardless of the fact that the keen air is accompanied with a clear sky, and in a few hours there will be such a meeting of sun heat and fire heat as to try severely everything at all tender, and where the very free admission of cold air will act almost as prejudicially as the extra dry heat? A very small fire in a cold morning, or no fire at all when the sun may be expected to act in a couple of hours, would often be much better than putting on much fuel; at least all the above little matters should be noted before doing so.

Much economy may also be effected by so managing the fire that the brightest part is always farthest from the furnace door, so that the smoke and steam may be burned by passing over the live coal. The more these matters are insisted on the greater will be the economy in heating.

In this respect there is no comparison, as to the fact and observation required from the best stoker to a steam engine, and the best stoker to the furnace of a tropical or forcing house, or a house where frost is merely excluded. The first has chiefly to husband the heat from the fuel as to get the greatest amount of steam from the water. The gardening stoker, if he would excel, has not only to study and practise how to get the most heat, but he has to study all the attendant circumstances of atmospheric changes, as too much heat in his case is often more dangerous than too little heat. Except where the frost is allowed to enter, we have no hesitation in saying that more harm is done by overheating at times than by frequent underheating.

Where much furnace work has to be attended to, a good thoughtful stoker will be one of the most valuable men about a place. The fuel he saves by consideration will tell largely in an economical point of view. So much have we felt this, that without calling in question the wonders that the boilers advertised in our columns are to accomplish with such an economy of fuel—and no doubt the inventors and patentees honestly believe all that is said of any particular boiler—we have little doubt that such a stoker would make one, or other, or each of them, the most wonderful for doing so much with so little fuel. How is it, then, that stoking the furnaces in a garden has frequently received so little attention? First, because the matter has not been deemed sufficiently important; second, because good stoking has not been sufficiently appreciated; and thirdly, because many proprietors of gardens, from some short-sighted considerations, make economical firing impossible. We do not so much allude to such a case as that referred to the other week, where a gentleman would prefer the joints of his pipes to be injured rather than insert an air-pipe, and care nothing about the heat round a boiler getting freely up the chimney, provided the damper was always drawn out; we allude more particularly to those gardens where, though there are several glass houses, no one lives near them to attend to them; and to keep them safe large fires must be put on before the men leave, and these must act whatever the change of the weather. In such a case economy in fuel is out of the question.—F.]

PASSIFLORA QUADRANGULARIS AS A CONSERVATORY CLIMBER.

THERE is a growing inclination among gardeners to plant some of the hardier kinds of stove climbers as permanent decorative plants in the conservatory, and one of their first favourites is the above-named Passion-flower. I do not object to their choice, for, as far as the building goes, I consider a

offly and otherwise roomy conservatory one of the best places in which to show off and to enjoy the beauty of this noble and grand flower; but then I find from experience that even if ample space be allotted to it, it is not in every conservatory that it will thrive; and when it does not succeed I think it is the most unsightly of plants for such places. Besides, it is almost certain to be doing badly when all other plants are thriving. On the other hand, with favourable conditions and treatment, it will succeed admirably as a conservatory plant.

I would say to those who are about to plant *Passiflora quadrangularis*, Well consider your plans before doing so, for the term conservatory gives a wide range of temperature—from that of a cool greenhouse up to that of the stove. Some employers like these structures kept at one heat and some at another, and I would not advise anyone to plant this Passion-flower where the temperature is likely to be for any length of time below 55°; for although it will flower in a comparatively low temperature, it is a stove plant, and requires a certain degree of warmth quite equal to the above, even when at rest, and when growing it will be better of a considerably higher temperature. I have grown the plant for conservatory ornamentation, and with 50° of heat it may thrive for a season or two, according to the severity of the winter, &c., but it has afterwards failed to maintain a healthy appearance, and to get the wood well ripened off in winter was impossible; the foliage, likewise, was sickly-looking; consequently in the following spring the plant was too weak to afford much bloom, and gradually became weakened in constitution, total failure being the result.

Nevertheless, if the temperature is not lower than that above stated, and a higher one can be given at favourable times in the year, I should not hesitate to give this *Passiflora* a prominent position in the conservatory. I have found the plant succeed well in a rich and moderately-heavy turfy loam two-thirds, and one-third sandy fibrous peat. I am not sure that this is the best compost to grow it in, but I know of none than one or two places where this Passion-flower is growing well in a similar soil. A very successful cultivator of this plant for conservatory decoration is Mr. Stalker, the able gardener at Hemsted Park, Staplehurst, Kent. I have several times visited that place within the last two years, and I have always found this beautiful plant in flower more or less, and I believe Mr. Stalker has told me that he grows it in a similar soil to the above; and he gives an abundance of tepid manure water when the plant is growing freely, and it flowers with him as late in the year as the present time.—THOMAS REARD, *Hatfield Park.*

A FEW JOTTINGS AT THE DECEMBER EXHIBITION

OF THE ROYAL HORTICULTURAL SOCIETY.

We have had, many of us, our causes of complaint and grumbling at the Royal Horticultural Society's sayings and doings, but I think no one will deny that the Wednesday exhibitions are a great boon, especially in the dreary winter months. It is not merely that they bring together whatever is worth seeing at the season, but that you are sure to meet some one with whom you can have a chat on subjects dear to you, and talk of plans and projects, of future meetings and past successes or failures; so I for one felt grateful on Wednesday last (December 7th), when, after that dreary miserable Tuesday, I found the Council room gay with Cyclamens, Primulas, Orchids, out blooms of *Chrysanthemums*, &c. I am not, however, going to venture upon ground which has already been so well trodden by your reporter, let me note a few things more in detail than has been done, and first

Mr. Douglas's Stand of Chrysanthemums.—Two things were to be noticed in this: First, that there were some of the most perfect blooms of *Chrysanthemums* that could be staged. I very much question whether his bloom of Miss Marechaux has ever been equalled. Fine, too, were Lady Talford, Guernsey Nugget, and other good sorts. And then it was notable that he had ventured upon the innovation of introducing some of the Japanese varieties amongst them, and very well did Comet and the Mikado, with their curious sea-anemone-like forms, contrast with the more perfectly formed show varieties. Whatever Mr. Douglas does he does well.

Mr. Clarke's Cyclamens.—Who that remembers what the culture of this very beautiful flower used to be does not feel astonished at the improvement that has taken place in it? It used to take three or four years to make a good-sized corm, while here were some of really good size grown from seed sown

on January 22nd of this year, so that ten months are sufficient to make good flowering corms. We have succeeded in making our beves and sheep in half the time they used to take, and now we are able to do the same with our Cyclamens. What next? Can anyone contrive to make Auriculas throw offsets and increase more rapidly? Who knows? I pass on from flowers to two inventions which I think deserve notice.

Mr. Chapman's Exhibition Stand for Salads.—Intimations of Mr. Chapman's intention to essay something of this kind had been already given, and his ingenuity in the construction of the flower and fruit cases and other inventions led me to believe that his promise would be fulfilled, and so it was. A very neat tray for exhibiting them is the result. Round the edge is a narrow trough in which Mustard and Cress were growing, while the salad was temptingly displayed in the middle space. This will doubtless be a boon to those who are fortunate enough to be able to exhibit such things.

Mr. B. Looker's Acme Garden Frame and Ground Vinery.—I have already expressed my opinion, formed from personal experience, of the value of Mr. Rendle's plant-protectors, although several have thought they are not so valuable as I believe them to be; but when I think of my Lettuces covered up with a good bed of leaves, I feel that by-and-by I shall have opinions strengthened. Mr. Looker's invention is a combination of wood, earthenware, and glass. The earthenware is very light, something in the form of chains, while the light wooden frame is so contrived that, though light, it gives great stability to the whole structure; and ventilation is provided for along the top, the little earthenware case of which the ridge is composed taking off easily, while the glass can be readily taken out for the purposes of watering. I am inclined to think that this little span-roofed frame will be found a great benefit to the owners of small gardens, as its neatness is quite equal to its usefulness.—D. Dool.

THE POTATO AND ITS CULTURE.—No. 4.

MISCELLANEOUS NOTES.

In sorting seed Potatoes, care should be taken to pick out the weakest eyes, leaving two or three strong ones. One good stiff shoot is sufficient, but one eye is not to be depended upon, for it may be destroyed. This applies to those varieties which have numerous eyes, and to those that are not large enough to make two or more sets.

A new and most excellent variety has lately been introduced into this country under the name of the King of the Sea. About February in the present year I purchased 1 lb. of this Potato, comprising three fair-sized tubers. Of these I made thirteen sets, each set having one eye, and I planted them in a warm border under a south wall about 14 feet wide. I drew out a trench 18 inches wide, and the same depth, laying the soil on each side of the trench. I then applied a compost of wood ashes, leaf mould, very old cow dung, and some well-chopped turf, and as my man threw it into the trench I mixed with it some of the soil which had come out of the trench, and which was very light. I planted the sets rather less than a foot apart, and then covered them with 4 inches in depth of soil. As it was very dry I watered the row. The weather continued very dry, and having little or no water, no more notice was taken of the plants till they began to come up. I then watered them with liquid manure (formed from sheep and fowls' dung), and a week later again with clear water. When they were dry I earthed them up a little, and as they advanced I continued to do so till they attained their full growth. On the crop being taken up the produce weighed 30 lbs. of very large and middle-sized Potatoes. I firmly believe if it had been a favourable season the 1 lb. would have produced 80 lbs. It is an excellent Potato for culinary purposes, and when it becomes more known no doubt it will be very largely cultivated.

Myatt's Prolific Ashleaf Kidney stands next in my estimation both for cropping and for flavour, and is more suitable for dry summers than any variety I know. I grew it extensively this season in a very dry situation, where the soil is of such a texture that it may be termed as light as ashes; I had a very good crop, and the tubers were of fair size.

It is a very bad plan to grow year after year the same kinds of Potato, and in the same situation, for they will assuredly degenerate, and if this course be persisted in will dwindle away. I should recommend after the Potato of one sort has been grown in the same garden or field for two years, it should be removed for a time, and grown in just the opposite kind of soil. In some instances the soil varies even in the same garden. I have

known peat to exist in one part of the garden, and quite a sandy soil in another; and, again, on our farm, there is one field of eight acres, a part of which is very stiff marl or loam, while the top end is very light; the Potato can be grown to every possible advantage where the soil is so divided. I quite agree with the late Mr. Paterson, in saying that maiden soil is the best for Potatoes, especially that which was meadow land previous to breaking up.

I will give an instance of what I did with a small plot of ground which had been used as a cottage garden for, I may say, centuries, and which had been condemned for Potato-growing. I trenched the ground as deeply as possible, sometimes turning up quite a yellow soil, I then planted the sets just as I have recommended under the head of planting, allowing about 14 inches from row to row, and 8 inches from set to set. I flat-hoed once, and never touched the ground again till I took up the crop, when I obtained twelve bushels of good-sized tubers, and two bushels of seed Potatoes. The ground was 12 yards long, and 10½ wide.

I recommend getting the crop in early, and then there is more likelihood of obtaining the produce before the wet and bad weather sets in, whereby decay of the tubers is promoted. The exact time for planting must be left to the discretion of the grower, who will be guided by the weather.—J. C. Lewis, *Gardener and Bailiff, Sudbury Rectory, Derby.*

NOTES ON THE CHRYSANTHEMUMS AT LIVERPOOL.

THERE was at the show nothing to speak of among the Japanese varieties, which was a matter of surprise to me; though their being later in blooming than the other varieties may have been the reason of so few having been exhibited, and the same reason in all probability will lead to their being grown for decoration and cut blooms.

Of the cut blooms, Eva, white, was undoubtedly the first on the list, being followed by Mrs. Heale, Golden John Salter, and John Salter, very good. Bronze Jardin des Plantes was of astonishing size and beauty. Mr. Gladstone was beautiful in colour, but smaller than it might have been. Of Prince of Wales I am sorry to see there are distinct varieties sent out by two different firms, causing confusion among growers. I give the preference to the light red variety, though the other is very fine. Rev. J. Dix showed well up to the front, as did also General Slade and Baron Baust. Yellow Perfection was a very pleasing good variety. Guernsey Nurset and Princess Beatrice were very fine; also Oasian. Of others I noticed Empress of India, a fine bloom, but open in the centre; Isabella Boff, a charming variety; Alma, also a good show flower; Cherub, a very fine bloom; Sir Stafford Carey, which, though placed last on my list, is by no means the worst, but, on the contrary, one of the most striking blooms. The above were the cream of the show in cut flowers.

The plants in the large-flowered section I will take in alphabetical order, Annie Salter being first. This is a well-known variety, and should be in every collection. Aisidne I was sorry to see come out so badly, as it is very fine with Mr. Bronze Jardin des Plantes, very fine, is an extremely useful variety, and Cherub pleasing. Cleopatra also came out well. The Christines, White and Golden, were good, but have, to my taste, too rough an appearance. Faust was very telling. Fingal was also fine, but rather loose and open-centered. Florence Nightingale, a very useful, good variety, was shown in good condition. General Bainbridge is a very fine late variety. Gloria Mundi, fine free variety, was rather too far gone. Hereward, a very fine flower, is very effective. Jardin des Plantes was one of the finest. John Salter is likely to be generally grown. Julie Lagravère was about the only one of its colour shown very good. Lady Harding and Lady Slade were both very fine, and are two very useful varieties; but Lady Talford is grand; it struck me at once, and was shown well in several collections. Lord Derby is a very good dark purple; Mr. Brunlees a very large flower and good; Mr. Cullingford, though one of the best, I do not remember seeing. Mrs. G. Randle was very fine in one collection only. I found it was faulty in several collections, as it is with me. Mrs. Hulburton was more like a Dahlia than a Chrysanthemum; this is a good variety, and is to be depended on. Pink Pearl was very good, but I have not Pink Perfection down in my notes. Prince Alfred was very fine, but inclined to be open in the centre. Sir Stafford Carey seemed to be a favourite with several ex-

hibitors. Fleur de Marie, a large, white Anemone flower, was very effective.

Coming to the Pompons, Adèle Bisette was very beautiful; the same is true of Andromeda. Aurore Boreale was charming, the colour being so varying. Bijou de l'Horticulture (a long name, truly), an odd variety, was very good, and Bob was better than usual. Dina Dina was smaller than I am accustomed to see it. Hélène, a fine rose-coloured flower, showed out well; but Lizzie Holmes was better. Middle, Marthe was also fine and effective. Of the Anemone-flowered Pompons Cado Nulli was very fine—in fact, the most perfect specimen in the Hall; and Mrs. Wyness, a very fine free-flowering variety, came out in the front rank.—STEPHEN CASWELL, *Bent Hill Gardens, Prestwich, Manchester.*

PLANTING.

No time could be better than this for planting and re-planting all kinds of evergreens, and planting for shelter, for profit, and for cover. The ground is now almost moist enough for common purposes, and still, notwithstanding the late frosts, retains much of its summer warmth. We are rather pleased that some remarkably on planting have drawn considerable attention to the subject, and more especially to the importance of planters in exposed places paying more attention to the number of times the plants have been moved, and the distance they stand apart, than to their mere size or height. In nothing more than in planting will it often occur that the cheapest goods are by far the dearest, if not worthless and useless in the end. It is not the fault of our tradesmen who deal in trees and shrubs. People will have things cheap, and the nurserymen to live must occupy as little ground with them as possible. They would only be too glad to send out sturdier hardier plants if purchasers would consider that it was to their interest to give a better price for a better article. As a case in point, we may mention that two or three years ago a lot of Larch was taken to an exposed place. The sight of the nice trees, with their smooth bark and slender twigs, would have shown us, even if we had not otherwise known, that these trees were taken from nursery rows where each stem pretty well rubbed its neighbour stem, so thickly did they stand, one thus protecting the other. To turn out such close-packed trees in an exposed place at 4 feet apart and like turning one out of a cosy room into the clear sky of a cold night. Very few of these plants survive—none thoroughly healthy—and the life of a valid or a care was sufficient to kill them. At the same time and place other Larch trees were planted, not taller, but much more bushy, and with rough hardy stems, the plants having stood 15 inches or more apart in the rows. Not one of these plants gave way, even in the bad seasons which destroyed the others; and the other day we noticed that many made long leading shoots last summer, and no Larches could look more healthy and flourishing. They cost about double the price of the trees first alluded to. For a definite, sure, pleasant result, they were well worth from three to four times the money of the others; and as we think they had been at least twice replanted, of course the work and the extra ground would have to be paid for. One thing in their favour was, they were carefully taken up and quickly and carefully planted.

This leads us to restate—and the planting time is our excuse—that if we were to plant largely in the way of woods and cover, we would not trouble ourselves with seeds or raising young plants, as the seedmen and nurserymen would thoroughly bear us in that, but we would have a little nursery of our own in which we would keep the trees a year or two after receiving them from the nurseryman, and by giving them more room than the dealer could be expected to afford, we would thus prepare them for more exposed positions. Another great benefit we should derive would be our being able to lift our plants just as we wanted them, and not too many at a time. When trees that come from a distance do not succeed over-well, we are apt to forget how the roots may suffer in trucks and waggons during the uncertainty of the winter months; and when, from the vast numbers obtained at a time, a considerable period must elapse before they are all planted, those who have no such home-store to go to, and resolve to plant this season, will act wisely, in our opinion, when ordering from their nurseryman to make inquiries, not merely as to the height of the plants, but as to the times they have been moved, and the distance they stand from each other. Great disappointments often take place because mere height and price are the only considerations; many a man would give a

double price to have a triple assurance of success. The thinner plants stand, so as to so far *un-nursery* them, the more they must be paid for, and the more fitted will they be for exposed cold situations.—R. F.

PLANTS IN FLOWER DURING NOVEMBER.

- Nov. 2. Hedera Helix arborescens
- Hedera digitata
- Jasminum nudiflorum
- Asplenium adnigratum
- Potentilla alba
- Collinsia bicolor
- Dianthus Caryophyllus
- Lactuca
- Aster
- Moric Pare
- Spiraea
- Petraeus
- Crucifera stylosa
- Monarda purpurea
- Primula acuminata
- Arenaria hirsuta
- Claytonia perfoliata
- Eragrostis alpinus
- Villarsii
- Andria deltoidea
- Mooriana
- Delphinium Belladonna
- formosa
- Cyclamen europaeum
- Jasminum puberulum
- Phlox Drummondii
- Ebermeierianus scabell
- Lonicera Douglasii
- Aconitum autumnale
- Villarsii
- Pyrethrum roseum
- Panthium plenum
- Golden Feather
- Escallonia rubra
- Lycocotria formosa
- Callirhoe platyglotta
- Rudbeckia fulgens
- Saponaria tuberosa
- Ecklonia metallica
- glauca
- secunda
- Echinops bunnianus
- Aster grandiflorus
- Tropaeum
- Myosotis poliflorus
- Antirrhinum majus
- Tactes patula
- Crocus scirvus
- Beyci
- Hammulis virginica
- Garrya elliptica
- Aporosa umbellata
- Saponaria tuberosa
- Centaura scabellifera
- pinnatifida
- 5. Nepeta violacea
- Godalia rosea
- Colebitum autumnale plenum
- Festuca ovina
- Vernonia
- Rose Glabre de Bion
- Mentha China
- Cerasus China
- Chrysanthemum
- Fuchsia coccinea
- globosa
- Anagallis speciosissima
- Phlox procumbens
- various
- Konica maritima
- Hydrangea hortensis
- Polygona Sibboldii
- Thymus compactum
- Gilia tricolor
- Ornithoglossum
- Cedronella
- Hesperis matronalis
- Nictandra gracilis
- Pumilio Larente
- capensis
- Anagallis alata
- Clematis Jackmanni
- Clematis fruticosa
- maritima
- Sylvia coccinea
- fulgens
- Aragal's grandiflora
- Tricyrtis hirta
- Verbena venosa
- Hollyhock grandiflorum
- Verbena pulchella
- Malope grandiflora

- Nov. 5. Campanula pentagona
- mirabilis
- carpatia
- pyramidalis
- Daisies, double
- Gynerium argenteum
- Blachycome ibidifolia
- Erinus alpinus
- Tropaeum majus
- Ceratium tomentosum
- Aster chinensis
- Tropaeolum pererinum
- Coronilla varia
- Mirabilis Jalapa
- Eubicus atrosanguinea
- Andrilla major
- Anemone japonica
- Dracopisium moldavicum
- Chrysanthemum nanum
- Salvia Herbimaria rubrum
- purpureum
- Centaura Cyanus
- Nigella hispanica
- Veronica dentata
- incana
- speciosa
- spicata
- Rose Mrs. Bosanquet
- Arenaria alpina
- Gum rivale
- Solanum paniculatum
- Solanum nigrum
- Oxalis rosea
- Petunia grandiflora
- Tetradlea arvensis
- Hibiscus africanus
- Leptodermis
- Nemorola inodora
- Lupinus novus
- inamabilis
- Celsus eretica
- Linaria hepatica
- Centaura virgata
- Ochlocha pulcherrima
- Polygona truncata
- Lobelia spicata
- 14. Arbutus Uxelo
- Meconopsis aurea
- Hypocistis edycinum
- Xeranthemum purpureum
- Mithella annua
- Convolvulus mauritanicus
- 15. Adonis autumnalis
- Linum catharticum
- olium
- Lysimachia ciliata
- vulgari
- Centranthus cyathiflorus
- Althaea chinensis
- Coccyopsis erantiora
- Asteris nana coronaria
- Clarkii pulchella
- Delphinium Ajacis
- Consida
- Armeria maritima rosea
- vulgari
- Calandrinia officinalis
- Gnaphalium fontinale
- Zinnia americana
- Calyceanthus dentatus
- Erica stricta
- ramiflora
- Calandrinia speciosa
- Alyssum compactum
- Clematis florida
- Vilba
- 25. Athanasia annua
- Apatina celestis
- Lupinus polyphollos
- Achillea Ptarmica fl.
- Viburnum Tinia
- lucidum
- 26. Vinca major
- minor
- Viola odorata
- tricolor
- Statice Linochora
- Chelone barbata
- Linaria alpina
- Cymbalaria
- purpurea
- Daphne Genkwa
- Laureola

—M. H., Achlam Hall, Middlebrough-on-Tees.

WONDERS OF AN AMATEUR.

I wonder why, among all the remedies suggested for worms in pots, the simple one of mustard and water is never mentioned. I have used these ingredients—a teaspoonful of mustard to a gallon or so of water—applied when the soil in the pot is somewhat dry, and have found the result most successful. Not only is the enemy dislodged, but the looker-on has the gratification of seeing him come to the surface as soon as the liquid is applied. I may add, that I have never observed

any injury result to the plants from this treatment, though I have tried it both in the case of bulbs and of hard and soft-wooded greenhouse plants.

I wonder why we amateur gardeners are so often advised to turn out our Camellias into hot pits while they are making wood, and then to keep them out of doors till late in the summer. For two years I have treated half of my Camellias in this way, and have kept the remaining half in a shady part of the conservatory with little other attention than watering and syringing, and have found those treated in the latter method greener and healthier in appearance, earlier in their blossom, and equally full of bloom buds—buds, too, which are not so liable to fall off as they are from plants which have been exposed to change of temperature.—R. S.

HOT-WATER CIRCULATING DOWNWARDS.

I have read the letter written by "POOR GARDENER" (page 370), in which he laments the water not circulating in his fernery owing to the pipes being a trifle lower at the end farthest from the boiler. He will not believe that water will go down hill in pipes; therefore, it may interest some of your readers, as well as "POOR GARDENER," to know that water will easily flow down pipes. We have a greenhouse where the flow-pipe enters at one end, and in the entire length of the pipe the fall is 22 feet, the rate of the fall being 10 inches in every 4 feet. There is an air-pipe fixed in the top of the fall of pipes, and another at the elbow at the other end of the house. The return-pipe goes back to the boiler on a level, and I have not found any difficulty in keeping out the sharpest frost we have had during the last two winters.—R. GIDDINGS, Gardener to W. H. Michael, Esq., Cholmeley Park, Highgate.

[There can be no question as to heated water going down if the proper conditions are attended to. We never like a hot-water pipe to go lower than the boiler, but we understand the present Mr. Weeks and his veteran father, who paved the way for all improved heating by hot water, got over that difficulty likewise. Meanwhile we would rather have every hot-water pipe above the level of the boiler, except where the pipe returns to the bottom of the boiler. At the same time we do not consider the arrangement of heating you have in your greenhouse, and that which a "POOR GARDENER" has to contend with, as at all desirable, because additional air-pipes are necessary. With your air-pipes you need have no difficulty, but the "POOR GARDENER" is not allowed to have an air-pipe, and in such a case, in general, free circulation would be impossible. The more, from different causes, that the water varies and sinks in level in the pipes, the greater will be the tendency of air to accumulate at the highest point, where the piping enters the house; and if the air there should fill the pipe from top to bottom, even though the length of the tube of air should only be a few inches, a strong fire would be more apt to burst the pipe than make the heated water pass through the air. A small body of air thus shut in between two bodies of water becomes pretty well as impassable as a firm wedge of marble. Have an air-pipe there and always open, and there will be no confined air, no stoppage to the water's circulation. The late Mr. Weeks had taps and pegs in such places. We are not sure who first used the small open pipe. Your kind statement would have been in unison with the answer given at page 370, but for the mistake of leaving out the word "not." A period should read thus—"The air-pipes might be tried before lifting the water-pipes, but if even that be 'not' done, the heating will never be properly effected," &c. Where there is much pressure, it is as well to have the end of the air-pipe outside the house, and the end bent a little downwards, as then it is less likely to get clogged with dust, or from insects lodging in it. A small gas-pipe answers admirably.]

NEW BOOKS.

The Miniature Fruit Garden, or the Culture of Pyramidal and Bush Fruit Trees, &c. By THOMAS RIVERS. Longman & Co. Sixteenth Edition.

We do not usually notice new editions, but of such a popular work as is this, and its being the sixteenth edition, we make an exception, though only to quote the following from its preface:—

"As a prominent but not new feature in this enlarged edition, I may refer to the management, and above all the protection of low luteran cordun fruit trees. I have also pointed out more forcibly than in former editions the capability of growing choice Pears and Apples

in any low cheap walls, and also against walls in kitchen gardens not fully furnished with trees,—in short, in all bare spaces so often found between wall trees in old gardens. These methods of cultivating Noisette Peas and the finer kinds of American Apples are worthy of much more attention than they have hitherto received.

"The method of cultivating the Prince Engelbert, and one or two other kinds of Plums as vertical single cordons, has been practised here for some few years; it is original, highly worthy of attention, and may be made a profitable venture, not only for the amateur but for the market-gardener.

"The management of those charming structures—ground vinerias, in this edition more fully gone into than before; in short, all the modes of culture hitherto recommended have been revised and made as perfect as practice can make them, for it must be recollected that all the modes of culture here recommended have been well tested, and no foreign practice recommended till found adapted to our wet English climate, the mean temperature of which is just about two degrees too low for the choice kinds of fruits to ripen without assistance."

The Lectest Sugar Question. By E. F. DE MAN. London: Ridgway.

We warn our readers against throwing away 3s. 6d. on this ill-written, unpractical pamphlet. There is not a suggestion in it that is useful, and long French quotations are given for no better reason than that they "will read more gracefully, especially for the fair sex."

DECEMBER CATERPILLARS.

It is a little remarkable that the caterpillar of the Butterfly, which claims the highest rank amongst our "Britishers," passes the winter in a torpid state. For this reason it may be considered remarkable, that to an extent it may be assumed that there is a certain check to the increase of a species, for in some winters many of these hibernating caterpillars must perish from various causes. Few have been so fortunate as to find the caterpillar of the Purple Emperor (*Apatura Iris*) at any stage of its growth; and for an account of its early history in particular we are indebted to the researches of Dr. Maclean. The egg is very much like a fossil Echinus in miniature denuded of its spines, and the little Emperor (to be) quits his shell about the end of July. Changing its skin in a week's time, it then exhibits two curious horns attached to the head, each of which is seen to be slightly cleft. Dark brown, too, when first hatched, it has now assumed just the tint of the Sallow on which it prefers to feed, though occasionally it is found on the Oak, according to the oldest observers. The mode of aiding digestion adopted by the young caterpillar is curious: having eaten its fill off some leaf, it then marches to the tip, and fixing itself there, remains motionless, raising its head in the air in the manner of the Peas Moth caterpillar. Some time in November it seeks out a twig to its taste, and forms a slight silken web on the bark, and on this it rests extended at full length, with the horns pressed together, and awaits the favourable influences of spring. When larger, this caterpillar rests in an almost straight position, though Mr. Newman observes that "when feeding, it bends its somewhat obese body with the facility, and I would almost say elegance, of a slug; but I fear many of my readers will scarcely appreciate the comparison. If annoyed, it contracts its body, assuming a very lumpy appearance." The peculiar horns on the crown are now established in their matured state, and are seen to be roughened over with small points. They have no separate power of motion, waving to and fro with the head. In colour they are greenish blue, with black tips. The whole body is slug-shaped, tapering at both extremities, and crossed by several transverse rows of warts. At the anal extremity are two points nearly parallel. The general colour is green, white on each side, in the line of the spiracles, there runs a slender yellow stripe; starting from this are seven oblique yellowish-white stripes, which slope upwards, but do not reach the middle of the back. The under surface is also green. The head of the chrysalis, which is seldom found, terminates in two short joints, and the body of it shows faintly the oblique stripes which adorn the caterpillar. The nearly adult caterpillar of the Marbled White Butterfly referred to last month, lives solitarily near or on the surface of the ground through the winter. There is a species much inferior in size to the preceding, but an entomologist records that he has several times observed, in the woods of Northamptonshire the attacks made by the Marbled White on his imperial relative, when he descends to the lower regions of the air, or settles in some damp spot.

A pleasant sight is it in a woodland walk to see the graceful

movements of the Speckled Wood Butterfly (*Pyrarga Egeria*) as it passes along the "ridings" or skims over them. The caterpillar producing it may be found in December, as also in other winter months. The eggs from which the winter brood emerges are laid in July or August. The young caterpillar feeds on various grasses, and does not grow much before it hibernates. Sepp, a continental naturalist, reports that specimens he had, changed their skins five times before winter. The head is black when the caterpillar is first hatched, but with the first moult it becomes green. With the growth of the early grasses in spring this little creature begins again to feed, and rapidly increasing in size, is generally full grown by the end of March. The body of it is shuttle-shaped, the divisions of the segments being clearly marked, and each being slightly wrinkled, which gives the appearance of their being again divided; at the anal extremity are two parallel points. The whole surface is covered with small raised points, from each of which there rises a stiff bristle. The general colour is sometimes olive-green, sometimes an umber-brown; in both kinds we have three stripes, each of which is triple, being composed of a dark smoke-coloured central stripe and two yellowish or whitish stripes. The chrysalis is fastened to a silken web on a grass stem, or some plant near the food of the caterpillar. There is also supposed to be a summer brood of the caterpillars of the Speckled Wood. The caterpillar of the Wall Butterfly is closely allied to the preceding, and the two Butterflies resemble each other in one singular particular—they have the eyes hairy. Hibernating individuals of the autumn brood of the caterpillars of the Wall (*Pyrarga Megara*) rest upon low herbage, close to the ground from September till March usually, nor do they appear to eat during that time, as is the case with some grass-feeding caterpillars amongst the moth tribes. The caterpillar of the Wall feeds chiefly by night, remaining through the day with its body extended along a blade of Grass. In many respects it resembles the one just described, having a similarly shaped body, with anal points, and being also studded with minute warts. The colour, however, is apple-green, the head being of a deeper and duller tint, and also a narrow stripe down the back; there is a pale greenish-white stripe along the sides; the legs are almost colourless, and half transparent, the claspers being of the same colour as the body; the points at the extremity are tipped with pink. When of full size, this caterpillar suspends itself by the tail, and becomes a chrysalis, the Butterfly emerging in May.

A good many of the caterpillars belonging to the extensive family of the Noctua live from autumn on to the spring or summer. Amongst these are several belonging to the genus Noctua, individuals of which turn up occasionally when the entomologist is digging round the roots of trees in fields, or when he is examining the sparse herbage along the hedge-banks. The caterpillar of the Double Dart (*Noctua Augur*), though a feeder upon Whitethorn and Sallow, usually passes the winter near the roots of low plants. The head in this species is small and slightly notched, and Mr. Newman observes that when crawling it "stretches the head forward, and moves it about in a leech-like manner." This caterpillar has a very smooth body, of a dull purple lue, varied with darker markings, and along the line of the spiracles there runs a stripe of rich brown; upon the back there are some white spots arranged in pairs, part of these being indistinct; the legs and claspers are pale and look nearly transparent. It attains maturity in the month of May. A rare and pretty species is that known as the Lesser Ingailed (*Noctua confusa*), in England apparently occurring only near Darlington, and being restricted in Scotland to two or three localities. The eggs are laid in the summer upon low plants indiscriminately, though the caterpillar seems most partial to the leaves of the Moss Campion. Unlike some of its brethren, it attains a good size before hibernation. The head is smaller than the second segment, almost round, having upon the face two crescentic marks, placed back to back. The body is greenish-yellow, with fine lines of brown distributed over it. The straight stripe, nearly white, runs down the middle of the back, while on each side of this, from the fourth to the tenth segment, is another stripe, and between this and the upper one there is a black spot on each segment. The spiracles are black, surrounded with white; the feet are black at the tips, the claspers much paler than the body. The cocoon is ingeniously constructed by the adult caterpillar of particles of leaves, mixed with earth, and interwoven with silk. A very rare British moth is that called the Feathered Ear (*Pachetra leucophaea*), apparently confined entirely to one locality in Surrey (near Mickleham), where it might be worth the while of collectors to hunt

for the caterpillar, which has been described by Guenée, the acute German entomologist. He has found it feeding on "tufts of grass on commons, and in dry woods." The head is large and light brown, giving the caterpillar an odd appearance; the claspers are small and short. The body is velvety, and yellowish grey; along the back there is a very conspicuous stripe, and below this on each side, a faint stripe, and another, also indistinct, in the line of the spiracles; in the second segment there is a brown plate, with a shining surface. Abroad, the cocoon is made amongst Moss in April, the moth appearing in July.

The caterpillars of the Mottled Rustie (Caradrina Morpheus) feed throughout the winter at intervals when the weather is open; at other times they rest on the under side of decayed leaves, or even enter the earth for a short distance. They may be sought on Docks and other plants which are green through part of the cold season. The body is very plump, the head less, and over both these are numerous short bristles. The colour is brown, varying in tint, with markings along the sides of a wedge-like appearance, of a darker hue, and a pale line below these. The species occurs in many places throughout England. Another in this genus has a singular history. This is the Pale Mottled Willow (Caradrina cubicularis); the name, from cubiculum some have believed to have been given because it occurs in outhouses or barns; Mr. Newman believes that the authors of the name gave it "in allusion to the familiar habit of the caterpillar residing in a little cubiculum or lodging-room of its own construction." The moth lays its eggs in June on Peas or Beans growing in fields, and still more frequently on the growing Wheat. When these crops are cut down and housed, the caterpillars of this moth are, much to the disadvantage of the farmer, carried in with them. Here they feed through the winter, forming the temporary cocoons already referred to, as they move from place to place, being nearly full grown in early spring. These caterpillars have the body studded with warts, each giving off a hair; the body being short and thick, and the head rather small, and capable of being withdrawn beneath the second segment, the surface being shining and black. The upper surface of the body is a dull grey, sometimes greenish, the sides are smoky grey, the under side and claspers much paler. The Froated Orange Moth (*Gortyna flavago*) would probably become very common, were it not that the caterpillars are many of them destroyed before they are full grown by the attacks of an insect enemy. It has afforded matter for some speculation as to the mode in which the egg of this parasite is introduced, since the caterpillar lives entirely concealed in the stems of plants, such as the different species of Thistle, Burdock, Mullein, and Hemp Agrimony. When removed from this retreat, it does not roll up, but crawls off rapidly to seek some concealment. The stems of some of these may be examined for this caterpillar in December, though as yet it has been mostly found in this summer; if taken it must be transferred of course to some transplanted specimen of its particular food. The formation of the body is admirably adapted to its life as a feeder upon the pith of plants, being soft, maggot-like, and pliant. The head is horny, flattened, of a yellow colour; there is also a horny plate on the second and one on the last segment; these plates are brown, the rest of the body being dull white, tinged slightly with pink. There are a number of dots arranged more or less regularly on the back and a few on the sides; the legs are horny but not the claspers. The chrysalis has a curious projection in front of the head, and two sharp spines at the tail, by means of which it extricates itself from the stem when about to become a moth.—J. R. S. CLIFFORD.—(*English Mechanic and Mirror of Science*.)

PORTRAITS OF PLANTS, FLOWERS, AND FRUITS.

STENOGLOTTIS FIMBRIATA (Spotted Natal Orchid). *Nat. ord.*, Orchidaceæ. *Lin.*, *Gynandria Monandria*.—Native of Natal and other Cape of Good Hope districts. Flowers lilac, with purple blotches.—(*Bot. Mag.*, t. 5872.)

GLADIOLUS SAUNDERSII (Mr. Wilson Saunders's Gladiolus). *Nat. ord.*, Iridaceæ. *Lin.*, *Hexandria Monogynia*.—Native of Cape of Good Hope. Flowers scarlet and white.—(*Ibid.*, t. 5873.)

CASSIA MIMOSOIDES var. TELFAIRIANA (Telfair's Mimosa-leaved Cassia). *Nat. ord.*, Leguminosæ. *Lin.*, *Decandria Monogynia*.—Native of Zanzibar, and elsewhere on Africa's eastern coast. Flowers yellow.—(*Ibid.*, t. 5874.)

EULOPHIA HELLEBORINA (Helleborine Eulophia). *Nat. ord.*, Orchidaceæ. *Lin.*, *Gynandria Monandria*.—Native of Sierra Leone. Flowers white tinted with pink.—(*Ibid.*, t. 5875.)

TACSONIA QUITENSIS (Quito Tacsonia). *Nat. ord.*, Passifloræ. *Lin.*, *Pentandria Trigynia*.—Native of the Andes in New Grenada and Ecuador. Flowers pink inside, crimson outside.—(*Ibid.*, t. 5876.)

GEISSORHIZA GRANDIS (Large-flowered Tile-root). *Nat. ord.*, Iridaceæ. *Lin.*, *Triandria Monogynia*.—Native of the Cape of Good Hope. Flowers pale straw-coloured.—(*Ibid.*, t. 5877.)

GLOXINIAS—*Scarlet Gem*, *Negro*, and *Mlle. Jeanne Prevost*.—"Few genera of ornamental plants are more useful in their way for general decorative purposes than the *Gloxinia*, which to facility of culture adds the recommendations of convenience of size, variety of form and tint, profuseness of flowers, and a velvety richness of colouring which is almost unapproached. Need we wonder, then, that they are largely grown both for house decoration and for exhibition—though not much encouraged at the great London shows; and, moreover, that the varieties are very numerous?"

"Their culture is so simple and well understood, that we need not here devote space to explain it. Suffice it, then, to say that the variety *Scarlet Gem* is one of the richest and brightest flowers we have ever seen, and one which unanimously won a first-class award when exhibited last spring. The colour at the deepest parts is of a rich bright velvety tint of carmine scarlet, beautifully blended with a soft violaceous hue at the throat. This novelty was shown by Mr. Williams, of Holloway. *Negro* is a richly shaded violet purple, raised last spring by the Messrs. Veitch & Sons, amongst many others of great beauty and merit; and *Mlle. Jeanne Prevost*, a French variety of recent introduction, is a deep rosy lilac tint, beautifully spotted and rayed with violet in the month and throat. They all belong to the erect-flowered section of *Gloxinias*."—(*Florist and Pomologist*, 3 s., iii., 265.)

"A PENNORTH O' POT-HERBS."

"HERE'S your pot-herbs, a penny a lot!" Such is the announcement addressed, in stentorian tones, to the discerning public, by the proprietors of numerous stalls ranged on either side of Whitecross Street, St. Luke's.

My readers may probably not be acquainted with this locality. It is overshadowed by the vestige of the old prison, but adorned by public baths and wash-houses for the labouring poor, and illumined by the "Tabernacle," in which are held meetings for the moral and intellectual improvement of the costermongers and their families, and in which hundreds of their children are daily taught how to tread the path of life here, so that it may lead to realms of love and light hereafter.

Some people call this a "low neighbourhood," but I do not. I recognise the principle that where there is an up-hill there must be a down-hill. Wherever there is a high light, there must be a deep shadow; and therefore, as surely as the Pyramids have reared their summits for ages above the ground, even so surely did the nummulites, of which their structure is formed, work for countless ages in the depths of the sea; and as certainly as the mighty-winged albatross sails high above the ocean at a thousand miles from shore, even as certainly does the humble earth-worm penetrate the ground deeper than man can reach, so enabling the rain from heaven to sink and fertilise the soil. There is no occupation low so long as is honest; and thus we realise the words of the poet—

"Let every work be hallowed
That man performs for man;
And have its share of honour,
As part of one great plan."

Along the kerb on either side of this and the neighbouring streets are all sorts of arrangements for selling goods. These alone furnish, as it were, a complete record of the progress of shopkeeping; and, as the history of architecture has been called the history of the world, so in the gradual development of these stalls may be found the history of the growth of our magnificent shops, with their plate glass fronts reaching up to the second floor—even as it has been said, the hovel grew into the palace, and the cave became the temple.

Here is to be seen the most primitive form of stall—the supports being the legs of the proprietor, around whose neck an old tea-tray is slung. On this are sometimes displayed a few sheets of note paper and envelopes, a stick or two of very thin sealing wax, some pencils and pen-holders. Sometimes the edge of the tray is bent perpendicularly upwards, so as to form a wall; and in this case the article exposed for sale is a little pair of wheels made of wire; on the axle is fixed a small doll, which is wheeled along on this primitive bicycle by jerks on

either side of the tray, to the infinite delight of the juvenile population, who look up to these toys as the realisation of all that money can purchase. Sometimes the tray graces the neck of a woman, and contains a few yards of edging or insertion, wound round a blue card; a cap or two of her own make; a kettle-holder made of patchwork; a few yards of tape; a card of looks and eyes; and a strip of plus;—the whole stock worth so little—yet by this alone must the poor creature maintain herself and children!

Next comes a tray, supported on a pair of slight trestles, usually the centre from which is distributed a composition for cleaning cloth, &c. The use of this requires a basin of water, and necessitates that the eloquent vendor should have the free use of his hands, so as to be able to prove the efficacy of his preparation by removing stains of paint, grease, &c., from the jackets of all "believers."

Now we have the costermonger's barrow, piled up with vegetables, of which an extraordinary supply may have turned up in Covent Garden in the morning—Cabbages, Cauliflowers, Lettuces, &c. This is essentially a locomotive stall; the proprietor does not find it to his advantage to remain long on one spot, knowing that many of the women cannot come out to buy their vegetables, having work at home—shoobinding, machine working, and above all "the children" to look after. My informant told me that, rising at 3 A.M., he gets early to Covent Garden—buys Cabbages, Turnips, Rhubarb, Cauliflowers, or other vegetables, which he hawks during the morning; usually getting rid of his stock by about 12 o'clock. He then invests in Cherries, Apples, or such fruit as may be in season, which he sells during the afternoon, generally taking up his position (if the police allow him) somewhere near a school, just before 12 or 2, or from 4 to 5. In the evening he stocks his barrow with bloaters for supper, or oysters when in season.

Thus are the man's entire faculties, mental and physical, devoted to earning an honest subsistence, requiring as much watchfulness as to supply and demand, and the rise and fall in prices, as do the merchant and stockbroker; for, said my hopeful "coster," "Mr. —, and many others now in a large way of business, only begun as I did." He told me, too, that several costermongers not only use their own donkeys, but have bought others with their savings, and let them out by the day.

These vegetable stalls may be said to keep up a certain amount of business all day and all the evening; for when the whole stock has not been sold before dinner, the remainder is disposed of as night approaches at lower prices; little heaps are made, consisting of a few Turnips, Carrots, Leeks, Onions, a small Celery or part of one, a little Parsley; and these are the "lots" forming the subject of the proclamation which is the keynote of this paper.

And now let us see the purpose which these "pot-herbs" serve in the preparation of food; and I hope to show that they not only contain in themselves a certain amount of nourishment, but that they increase the value of the small quantity of meat which the wife of a working man may be able to place on her family table.

Everybody knows that fat and water will not mix; but that, whilst the water is hot, the globules of fat are separated and held in suspension in it; and as the water cools they unite again, and form a cake at the top.

Take a glass bottle, and partially fill it with warm water; add to this some melted fat, gradually heat, and stir it. Whilst the water is hot the fat will seem to mix with it, but as it cools it will rise to the top and form a cake. Again apply heat, and this time add a teaspoonful of brown sugar, stir it, and allow it to cool; behold, the cake of fat at the top will be just half its previous thickness. But follow up the experiment: apply heat a third time, add a teaspoonful of gum—allow it to cool—and you will find that the cake of fat will almost entirely disappear. Where has it gone to? The answer must necessarily be, that it has entirely mixed with the water.

Here then, is the secret of the use of the "penn'orth o' pot-herbs."

If we analyse 1 lb. of Carrots, we shall find amongst the ingredients of which the vegetable is composed, 1 oz. 11 grains of sugar, and 70 grains of gum. In 1 lb. of Turnips we shall find 280 grains of sugar, and 107 grains of gum. So that, we see, these two vegetables perform exactly the same office as the sugar and gum in the experiment, and thus utilise the fat in the food by causing it to mix with the other ingredients, and so enabling us to take it without the disagreeable effects previously alluded to.

But this is not all; these pot-herbs (and I have selected

these two as types of the class) not only serve as mediators, but bring in themselves a certain amount of capital into the concern; for we find in 1 lb. of Carrots 42 grains of albumen, and in the same quantity of Turnips 77 grains of albumen and casein. Further, in Carrots we find 1 grain, and in Turnips 35 grains of mineral matter; and the comparative importance of this will be recognised when we remember that in the body of a man weighing 154 lbs. there are 8 lbs. of mineral matter. But even this is not all; were every particle of the substances that we put into our stomach really digestible, the mass would become so closely pressed together that it could not be penetrated by the gastric or intestinal juice. Nature has guarded against this by giving us in our vegetable food a substance called cellulose, or woody fibre. This forms the walls of the little bags in which the starch and sugar in the plant are packed up; it is this which, when the sugar has dried away or rotted, causes the vegetables to become what is called "stringy" or "woody." Of this woody fibre we find in Carrots 231, and in Turnips 168 grains per lb.

The limits of this paper preclude my pursuing the subject any further. I can only just mention the tastiness which these plants impart to food. Who does not know the exquisite flavour added by the simple spike of Parsley, or blade of Celery? Who does not recognise the pungency of the Onion (in itself a nutritious and most healthy vegetable) or of the Shallot? And one word more—who does not look with wonder and admiration on the beautiful colours of the Beet and Carrot, and on the exquisite form of the leaves of the Parsley and Celery? And who is there that would say that a poor man would not enjoy his meal all the more, if the little piece of meat which has been boiled in his soup were served up nicely garnished with the gold and scarlet slices of Carrot, the silvery wedges of Turnip, and the emerald foliage of the Celery and Parsley? Thus to economy may be added beauty—beauty leads to refinement—and who shall say where refinement may lead? Need we, then, any more ask, What is the use of "A penn'orth o' pot-herbs?"—*ELLIS A. DAVIDSON.—(Food Journal.)*

ROYAL HORTICULTURAL SOCIETY'S SHOW AT NOTTINGHAM.

The preliminaries of the great provincial meeting of the Royal Horticultural Society at Nottingham, are now settled. The Show is fixed for the 27th of June next, and is to be held in the Castle Park, quite in the centre of the best part of the town. The special prizes already amount to £380; many more are yet expected, and the guarantee fund is complete. Well done Nottingham! If this meeting is not a success, it will not be for want of the will and energy of those who have undertaken the initiative to make it so.

CHRYSANTHEMUM CULTURE.

Your correspondent's remarks in your last issue seem calculated to mislead, for my experience teaches me that to produce creditable specimens manure water is indispensable. My practice is to give weak liquid manure at every watering, from the time they are placed in 8-inch pots till I can discern the colour of the flower buds, when I gradually withhold it. I also attach great importance to plunging the pots in some waste material—such as cinder ashes or old tan. Nature has, with few exceptions, provided the roots of vegetation with an equable temperature. Surely, then, it must be beneficial to the Chrysanthemum to protect its roots from solar influences. I have found the middle of July quite late enough for the last potting. It is generally admitted by experienced plant growers, that flowering plants should well fill their pots with roots previous to the formation of flower buds, in order to induce a greater profusion of bloom. This rule is applicable to the Chrysanthemum, but the plant must fail to accomplish this object if potting be deferred till August, as recommended by your correspondent.—*H. BENHAM, Upper Holloway.*

NOTES AND GLEANINGS.

The pods of the Ground Nut (*Arachis hypogea*) are frequently to be seen in the windows of small shops in the poor neighbourhoods of our large towns, where they are chiefly purchased by children, and are known to them as "monkey nuts." Their chief use, however, remarks *Nature* is for the expression from the seeds of a light-coloured bland oil, said to be extensively used for mixing with olive oil; and we have

even heard of the seeds being parched and used as a substitute for coffee, but we now read that in America they are used for making chocolate (so called); for this purpose they are beaten up in a mortar, and the mass compressed into cakes, and it is said to form a most agreeable chocolate without a particle of true cocoa. More than this, the Americans prepare the seeds as a dessert sweetmeat by parching them and beating them up with sugar.

PORTRAIT OF MR. RIVERS.

The following additional subscriptions have been received:—

	£	s.	d.
Grundy, Robert, Esq., Bury, Lancashire	0	10	6
Lee, Mr. George, Clvedon, Bristol	0	5	0
Prout, John, Esq., Sasbridgeworth	1	1	0
Sponcer, John, Esq., Boscawen	1	1	0
S'eggart, F. C. Esq., Weymouth	1	1	0
Wise, Thomas, Esq., Boston	1	1	0

NOTES MADE DURING A TOUR IN IRELAND.

No. 4.

THE VICE-REGAL LODGE, PHENIX PARK.

NEXT to royalty—royalty itself in Ireland—is the Lord-Lieutenant, and it is meet he should enjoy a royal abode. Such is the Vice-Regal Lodge, situated in the middle of the noble Phoenix Park; no better spot could be found, for it commands fine and extensive views of the Park in all its varied beauty, and of the surrounding country, with the Dublin mountains and other hills in the distance. The building is plain but elegant, substantial, and large. The private policies and gardens are of considerable extent, nicely furnished with trees, tastefully laid out, and pretty well maintained.

In the immediate front of the Lodge a square portion of about two acres bounded on three sides, south, east, and west, by a low balustrade wall, is very beautifully designed as an ornamental flower garden. There is a massiveness, a width, and a character about this in perfect harmony with the building that I liked very much; moreover, it was skilfully and tastefully planted, and in perfect keeping, which made it quite pleasing to look upon, and it reflected much credit on Mr. Smith, the very excellent and intelligent gardener.

The accompanying sketch, for which I am indebted to Mr. Smith, will give a far better idea of it than any mere description. Only one half of the design is here shown, as the other is precisely the same.

The Vice-Regal Lodge (A), a photograph of which is shown, stands on a flat plateau of grass, with a long broad gravel walk in front, and another walk leading from the portico, B, through the centre to another broad raised terrace walk against the low balustrade wall on the opposite side, which forms a beautiful promenade, overlooking the Park on the one side, and the flower garden, with the Lodge, on the other. That which makes this so extremely pleasant to look upon is the great breadth of open and well-kept green grass, and the simplicity of the design. How much more effective are these plain oblong beds when planted, and how much more easily and effectively can they be planted, than those narrow, sharp-pointed figures that look so pretty on paper! The great number of pillar Irish Yews placed at regular distances along the sides of the main walks, as represented by the little circles, also give the design a very distinct and rather elegant character. Along the balustrade walls numerous vases are placed, which were beautifully filled with Scarlet Pelargoniums and other flowers. Mr. Smith, in order to make the plants in the vases produce an immediate effect, adopts a practice which is worthy of being more generally known. It is this—tins are made to fit exactly into the interior of the vase, and are filled early in the season with plants, which are kept in-doors until established; consequently when put in their places the plants produce an immediate effect.

It will be understood that the design is on grass; c denotes gravel walks, which cut it up into squares; d represents a grass slope; E, vases; r, a sundial in the centre.

At the risk of being somewhat tedious, I shall attempt to give some idea of the admirable manner in which this garden was planted. Commencing at the portico, the oblong beds immediately in front and stretching round the extremity of the ground, measure about 30 feet by 15 feet. These have all a very neat, trim, and beautiful edging of *Cerastium tomentosum*. This cuts the connection, as Mr. Smith observed, between the

green foliage of the plants and the grass, and gives the beds a very dresy appearance, and a kind of uniform framework throughout, which tells well from the windows, the proper stand-point to judge from. These beds were all planted with a considerable degree of uniformity, and yet in excellent contrast with one another. After the *Cerastium* in each bed was a belt 2½ feet wide all round of some suitable plant; then the centres, 24 feet by 8, were planted with something else. For example—No. 20, which has its brother on the other side of the walk, was planted thus—after the *Cerastium*, a belt of *Lobelia speciosa*, dotted with plants of *Echeveria metallica*, then another thin line of *Cerastium*, and the centre Mrs. Pollock *Pelargonium*. This was very fine. No. 30 had for the centre *Pelargonium* Amy Hogg, one of the most pleasing and effective of all, and greatly admired in Ireland; then a belt of Mangles's Variegated, mixed with a few pink *Verbenas*, and the grey edging. No. 31, centre *Pelargonium* Madame Rudersdorff, a belt of Golden Chain, and the grey edge. No. 32, centre *Pelargonium* Cybister, and a belt of Flower of Spring, with the grey edging. From No. 33 to No. 41 the style of planting the beds was somewhat different. The centres were planted with one colour as in the others, the belt portion in oblique bands of colour at about the angle of 15° from the grass, so selected as to contrast well with each other. When the materials are well chosen as to colour, &c., and both grow of a uniform height, this looks well, otherwise it has a very untidy irregular appearance. One or two examples may suffice. Take No. 41.—Centre *Pelargonium* Excellent, then diagonal or oblique bands alternately of *Calceolaria Aurea floribunda* and *Iresine Herbistii*. This looked well, but *Calceolarias* being such "cattle" now, it is hardly safe to trust to them. No. 40.—Centre *Pelargonium* Christine, diagonal bands alternately of the silvery *Centaurea candidissima*, and a good variety of dark-leaved *Bet*; these contrasted admirably, and both colours harmonised well with the pink *Pelargoniums* in the centre. No. 36 had in the centre *Calceolaria amplexicaulis*, and diagonal bands of the dark-leaved *Pellia* and *Pelargonium* Lord Roxbury, with the grey edge of *Cerastium*, as in each of the others. No. 37.—The two extreme corner beds were planted with a few sub-tropical plants by way of trial, such as *Wigandia*, *Solanums*, *Cannas*, and *Custard-plant*. These, although they had grown pretty well, had but a shabby appearance; the situation is far too exposed for these plants. Glancing now at the centre, or at the centre of either side, where the beds form three concentric circles, there was a very pretty display, although not so pleasing on the whole as the other parts. Nos. 1 and 3 were planted thus—*Calceolaria amplexicaulis*, edged with *Pelargonium* Crystal Palace Scarlet. Nos. 2 and 4, *Governor*, edged with *Centaurea candidissima*, which was very effective. No. 5, *Indian Yellow*, edged with a light-coloured *Pansy*. No. 6, *Calceolaria* Prince of Orange, edged with *Calceolaria Aurea floribunda*. No. 7, *Pelargonium* Lady Constance Grosvenor, edged with *Flower of Spring*. No. 9, *Clipper*, edged with a yellow *Pansy*. In the outer circle, Nos. 17 and 25, *Verbena* Purple King, edged with *Cerastium tomentosum*; 18 and 26, *Pelargonium* Silver Nosegay, edged with *Iresine Herbistii*; and No. 22, *Pelargonium* Madame Barré, edged with *Centaurea candidissima compacta*, were only attractive. Several of the others were filled with such as *Pelargonium* Lady Collum edged with *Lady Plymouth*, and *Flower of Spring* edged with *Iresine Herbistii*, the plant which in Ireland takes the place of the *Colons Verschaffeltii*. In the vases, which were chiefly filled with *Pelargoniums*, *Governor* proved the most effective scarlet. This is a decided improvement on Pauch. Excellent is also very effective and suitable.

Such was the arrangement during the past summer, and it was a good one, doing Mr. Smith much credit. A great improvement might, however, be easily effected here, which would materially enhance the appearance, and that would be by the addition of a couple of fountains placed in the centre of the circular part. The appearance of water in a hot summer day, with the green grass and pretty flowers, has a most pleasing effect on the senses. Let us hope that some liberal Lord-Lieutenant may make the trial.

After these summer occupants have gone, the beds and vases are immediately filled with spring-flowering plants, such as edgings of *Cerastium* and *Silene pendula*, *Hyacinths*, *Crocuses*, *Myosotis dissitiflora*, *Calandrinia*, *Pansies*, *Wallflowers*, *Aubrietias*, *Narcissus poeticus*, *Tulips* of all shades, *Nemophilas*, *Saponaria calabrica*, and *Daisies*. On this part, however, it is not my purpose to dilate at present, but I hope to return to it on some future occasion. Judging by the splendid materials in preparation for next spring's display, I should say it will be

very fine. Mr. Smith informs me that the beds are already planted, so that I would advise all who may have the opportunity to pay the Vics-Regal Lodge a visit.

plant house having a three-ridged roof. This is used also for entertainments of various kinds. During the time of my visit it was filled with some fine plants of *Crotons*, and two large plants of *Cycas revoluta* and *circularis*. A little way off, again,

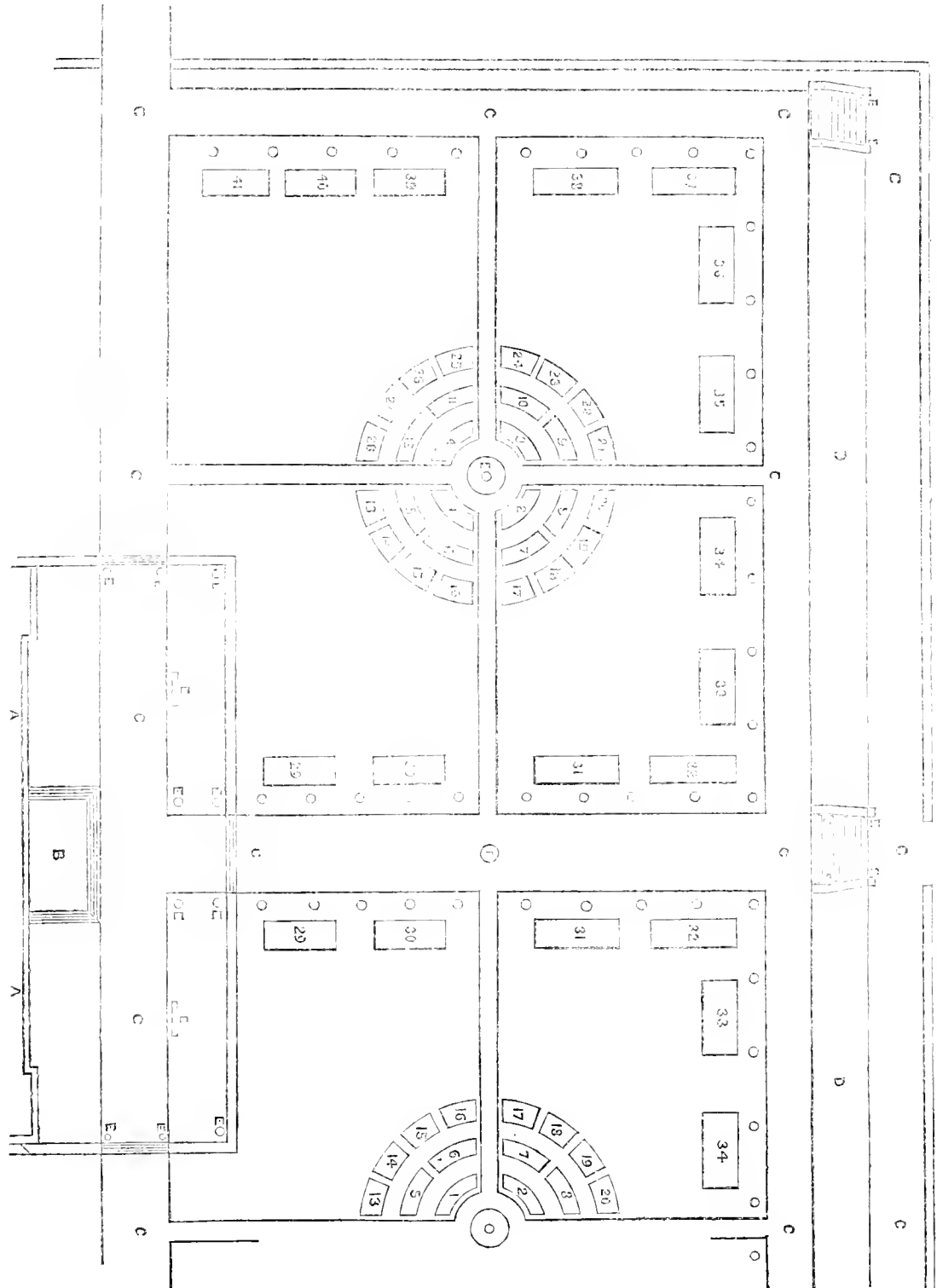

stands another house, a very useless and unmeaning structure, quite enough to try the temper of any gardener. As an aviary it might prove useful, but as a plant house never. Mr. Smith

has to grow great numbers of plants for decoration, and they are grown well. I observed great quantities of the *Euchais amazonica*, *Gardenias*, *Dracaenas*, *Allamandas*, &c.; also of the

Sugar-cane, which rather attracted my attention, as I had never seen it in such quantity. Mr. Smith informed me that he found it extremely useful and easily grown. Small plants in 48-sized pots look particularly graceful. In some other pits I noticed a few Orchids, the *Cypripediums* being good, also fine plants of *Alocasias*, *Cissus*, *Adiantum*, &c. One span-roofed pit contained a fine lot of Heaths, which I was well pleased to see, as these plants are such particular favourites. Azaleas were here also in great number and in excellent condition. Pelargoniums, of what are called the etage varieties, were extra good, plainly proving that Mr. Smith is an adept at plant-growing. At the Dublin Horticultural Show the Vice-Regal gardens must show the example, and it is done, many plants being grown for this especial purpose.

It is for fruits, however, and Grapes especially, that the Vice-Regal Lodge is chiefly famed, there being immense quantities of them required. In what is called the forcing garden there

is a range of houses 600 feet long, 450 feet of which contain grapes. It is divided into eight compartments. This is a noble one, having a sort of cruciform front, with a short path behind, forming a sort of three-quarter span, with a back wall about 9 feet high. These houses, or divisions, are all planted so as to produce a successional supply, No. 1 being the earliest and planted chiefly with Black Hamburgs, No. 2 and 3 with the same. From these the crop had been cut. The Vines appeared to be in fine condition. No. 4 was, again, Black Hamburgs. In this there was a splendid crop, over thirty bunches on each rod, and all well finished. No. 5 was a rather remarkable house, about 70 feet in length, the Vines treated on what is termed the extension system; three Vines—one at one end, and two at the other—being made to fill the entire house. The rods, seven in number, are trained lengthwise along the roof of the house until they meet in the centre, and right well they looked. The crop was something marvellous—

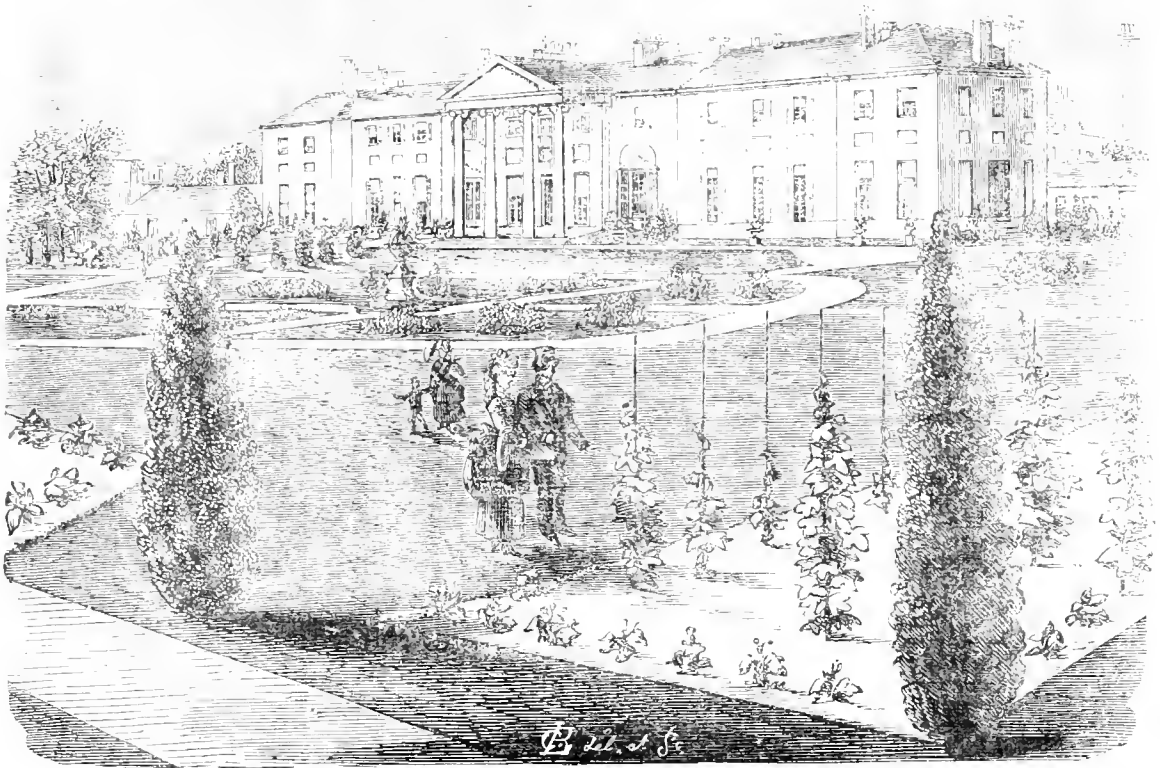

The Vice-Regal Lodge.

too heavy I fancied, yet the bunches seemed to "finish" well. Mr. Smith informed me that last season the crop was equally heavy, over 700 lbs. weight being cut. The roots of these Vines are all inside the house, and the health, the training, and the general appearance of the whole was very creditable. The next house, No. 6, was filled chiefly with late varieties, such as Alicante, Lady Downe's—the best of all late-keeping Grapes, Trentham Black, and Foster's White Seedling. The examples of this were excellent; it is, however, better suited for early than late work. No. 7 contained Muscats, the king of all Grapes. In No. 8 the Vines have only recently been planted. I observed a good many of Mrs. Pince's Black Muscat, a much over-rated Grape; a good keeper without doubt, and of fair flavour, but far from satisfactory as a cropper. This must give way to Madresfield Court Muscat, of which Mr. Smith had only one example. Royal Ascot was here also. This is a good and useful variety,

and well deserving of extended cultivation. The other variety in this house was Lady Downe's.

The Vice-Regal Lodge can boast of having one of the largest Pine stoves to be seen. It is a low ridge-and-furrow structure, 44 feet in length, 24 feet in width, and about 7 feet in height to the eaves of the ridges; these are seven in number. There is a broad walk leading through the centre, thus dividing the interior into two beds which are filled with tan. In this the plants, which are grown in pots, are plunged. The appearance of the house both externally and internally is rather pleasing. The broad path in the centre gives ample facility to view the plants, which can very seldom be done with Pines. Mr. Smith grows his Pines here in all stages—fruiting, succession, and suckers, and they all looked well, there being some very fair fruit. Mr. Smith spoke in high terms of the convenience in working such a house as this, and of its efficiency

generally. It is the only Pine stove he has, and many fine fruits are annually produced.

Into the other departments of this regal garden I shall not enter at present, further than to remark on the general excellence throughout. Peaches were grown well and abundantly; Pears, also; and cordon Apples were well represented. Vegetables commanded their share of attention, and were worthy of the place. In conclusion, I have to thank Mr. Smith, who has been for many years the gardener, for his exceeding kindness and hospitality.—B.

WORK FOR THE WEEK.

KITCHEN GARDEN.

LITTLE can be added to previous directions under this head. The operations of one week are but an epitome of what has been and still will be necessary for some weeks. It may be truly said that most of our operations at this season have no law as regards the time of performance, being entirely dependant on the state of the weather. Common sense will suggest to everyone desirous of excelling, that no opportunity should be allowed to slip by of getting the soil in a favourable state for the reception of the various crops which must soon be committed to it; and as the basis of success is allowed by all good practical gardeners to be a thorough system of drainage, no time should be lost in attending to this most material point. Whatever is done should be done well. I would never allow a drain to be laid down that was likely to become deranged in its operation, as the good that might otherwise be derived from it would be nullified from the difficulty of ascertaining where the defects were. As this kind of work may be done at any time when it is dry overhead, we shall do well to look to it in time. The surface soil must be occasionally stirred amongst *Cauliflowers*, *Lettuces*, and young *Cabbages*, and the latter should have the earth drawn round the stems to prevent them from being blown about by the wind. *Celery* and *Parsley* must be protected in severe frost. Let a warm patch of ground on a south border be prepared for a sowing of early *Radishes*, and in bad weather prepare a quantity of material for the protection of early crops of various kinds. These things must soon be put in requisition, and they ought to be at hand when wanted.

FRUIT GARDEN.

The renewing of fruit-tree borders where the soil is impoverished is a very necessary operation at this season; let as much of the old soil be removed as can be done without disturbing the roots, and its place be supplied with maiden loam; avoid using stimulants, which often induce over-luxuriant growth without a corresponding degree of fruitfulness. As a considerable difference of opinion exists on this point, young gardeners will do well to turn their attention to it. As far as my experience goes I hold it to be a fundamental point in the formation of borders for fruit trees that no stimulating manures should enter into their composition. I ought to add, however, that Vines are an exception, for they are gross feeders, and capable of assimilating a greater amount of nourishment than harder-wooded fruit trees. All the pruning, except of Figs and Apples, and most of the nailing of wall trees, as well as the training of a pollers, should be finished if possible by New Year's-day, and the same may be said of bush fruit. The making of borders or stations for fruit trees, too, should be autumn business. Wherever soil has to be introduced, September or October is the most fitting time, as the best of soils may be seriously injured by moving them in a wet state.

FLOWER GARDEN.

Protect tender plants, and in moderate weather, especially if dry, open the canopies or coverings a little for a few hours once a-week or so, in order to dispel damp. Do not, however, suffer the sun to shine on plants of this kind. In frosty weather a scheme of the masses or beds might be decided on, and the soil renewed according to the character of the plant. Little can be done now except in the way of preparation, and should frosty weather continue, it will afford every opportunity of having all the compost heaps thoroughly frozen. By repeatedly removing the encrusted surface, and piling it up every morning, many of the insects and their eggs will be destroyed—a point of no small importance to the cultivator. It will also be a good time to cart turf sods, peat, &c., and to lay by a good stock of soil most suitable for the various plants and flowers, without which it is next to impossible to grow them successfully. If leaden pegs are used for layering Carnations

(and these I should always recommend in preference to bracken or fern), a fresh stock may be cast and the old ones cleaned and straightened. If the florist can mend his own hand-lights and shades, they ought now to be attended to, and the metallic wire which has been used for attaching the stems of Carnations or Tulips to their supports, should be made ready for use and stored away in any place till the returning season brings it into request. Rabbits during the severe weather are apt to attack Carnations and Pinks. It would be worth while to try Mr. Rivers's plan of dipping small square pieces of cloth into brimstone, tying them to sticks, and inserting the sticks in the ground round the beds. Now is a good time to collect Rose stocks for another year's operations. In selecting these, discard the green-backed variety. Those stocks which were budded this season may now have the shoots cut back to within 6 inches of the buds. Buds of tender varieties should have a little moss tied round them for protection from frost. Sweep and roll grass lawns and gravel walks.

GREENHOUSE AND CONSERVATORY.

In pruning and training the climbers in the conservatory and other houses, some regard must be paid to the time when it is desirable the plants should bloom. Thus with stove climbers not required to flower before autumn, pruning may be deferred for some time; but for earlier display it should be done at once. Passion-flowers, Bignonias, and similar plants, which make long annual shoots, should only have their branches thinned and slightly shortened; while others, as *Convolvulus*, may be soursced-in. *Kennedya*s will soon be showing bloom, and what training they require should be done at once, but the pruning should not take place till after they have ceased flowering. Where Orange trees are grown to decorate the flower garden in summer, care should be taken to prevent their beginning to push previous to their removal to the open air, and this more especially if the trees are wintered in a dark-roofed house. When such happens the young leaves have always a thin, flabby appearance, and soon turn brown after the plants have been set out of doors, whereas if growth has been prevented till the trees are in the open air, the foliage will bear any amount of sunshine, and still look green and healthy. The introduction of the Chinese *Chrysanthemums* having caused a disarrangement of part of the stock, it becomes a matter of importance to rearrange matters, that groups or tribes may occupy situations according to their habits. But in keeping the conservatory gay with blooming plants, let the arrangement of the interior be occasionally changed by grouping the plants somewhat differently, and adding a few striking subjects, as some of the hardiest Palms, &c., for effect. *Chrysanthemums* decaying should be cut down, suffered to become somewhat dry, and removed to cold frames. Those who cannot afford frame room may secure them in some shed or outhouse for a few weeks, covering them overhead with clean straw whilst the frost lasts. If they are slightly frozen here it will not signify, only take care that they do not thaw too suddenly. Forcing pits will soon have to be kept in full activity to supply the various calls for plants in bloom, which, during winter, are more or less in demand in most establishments. Care should be taken before plants are moved to sitting-rooms to gradually harden them for a day or two, either by placing them in the conservatory or an intermediate house. Pay attention to the plants intended for successive blooming. Insects should be kept down, and every means afforded to keep the foliage clean and healthy. As, with the exception of forced plants, most other things are now in an inactive state, the temperature of the plant houses should fall to its minimum point, consistent with the safety of their various inmates.

STOVE.

Little can be said here at present. Use moderation in heat, ventilation, and atmospheric moisture. Beware of exciting the buds of *Orchids* before their time. Do this, and keep a somewhat drier atmosphere until the middle of January.—W. KEANE.

DOINGS OF THE LAST WEEK.

Gardening and Gardeners.—The gardeners of the olden times might well enjoy themselves in looking around them during the winter, as then they could take some compensation for their hard labour with hand and head when the days were long and the sun strong. The recollection of such scenes, and comparative liberty, combined with poetic dreams about the "loves of the flowers," and the pleasure of even in the humblest degree contributing to their loveliness, have induced many a youth to

enter the field of gardening to be deeply disappointed at finding that there is now no season of the year when there is anything like leisure time in a garden. Of course there may yet be genial and happy spots where gardening may be followed calmly and quietly, and where the imaginative and the poetical may be indulged in among all the digging, pruning, potting, fringing, &c.; but as a general fact it would be well for all dreamy youths, before taking to gardening, to be well indoctrinated with the idea that their case will be rather exceptional if, instead of the expected ease and quiet, they do not find that they must manage to put up with hard galloping from April to June, and pretty hard trotting every day in the year besides. Many gardeners will experience that they are rather amongst the fortunate ones if, from many extras put in their way in winter, they do not find themselves behind with their winter work when spring work ought to engage their attention.

We mention these matters more particularly because we have of late years been often sorry to see youths entering with high hopes on gardening as a means of living, and then leaving it, after wasting much time, because they found that the labour required from body and mind was too arduous for them, and that even holidays were few and far between. In all cases where numbers of youths are taken into gardens as apprentices, or improvers, or learners, it would be well to set before them stern realities, instead of allowing them to dream about flowery imaginings, as such youths, when disappointed so as to turn to other occupations, not only injure themselves, but keep the gardening market so overstocked, that those who have the natural capabilities, the requisite energy, and the determination to surmount all obstacles, find it all the more difficult to get on, or even to obtain suitable employment. Unfortunately, notwithstanding the vast increase in the number of gardens of late years, there has been a still greater increase in the numbers of those who aspire ultimately to manage them, and this is partly owing to the fact that many make a commencement in this direction who have never clearly calculated on the difficulties with which they must contend. These difficulties, as well as the pleasures, calmly looked at would induce many a youth to betake himself "to fields and pastures new," instead of even for a time throning that province of labour in which it is now so difficult to obtain remunerative employment.

It is sad to think at this inclement season of many gardeners willing to labour and unable to find employment; and it is equally melancholy to see so many youths and able-bodied men accustomed to country work, going from place to place in search of work for a day, or a week, with little in their pockets, and next to empty cupboards at home. Many country gentlemen who are able to afford it, would confer a great benefit in effecting contemplated improvements in ground work, grubbing, planting, &c., at such a season and in such circumstances; as almost any able-bodied man, though previously unused to it, can with a little supervision be made dexterously to wield a spade, or trundle a barrow. We would be inclined to look at such work in many cases as true charity, and charity dispensed in the best manner, so as not to rob the receiver of the wages of a true manly self-respect.

KITCHEN GARDEN.

A sharp frost on the 8th, and a fall of snow on the 9th, have confined our operations chiefly to wheeling, and to keeping lifted plants of Sea-kale, &c., under protection. The snow is one of our best protectors, and therefore for two days our cold pits protected a little have been left untouched. A dense fog on the 10th led us to hope for a change, but the wind veering to the north, and a rising barometer, may give us frost instead of thaw. Open weather would give much work, and help those who have little to do.

FRUIT GARDEN.

We filled several frames with Strawberry plants in pots, setting them on the surface with just a little bottom heat below them, as much is apt to injure them by encouraging mere growth.

On the 9th, as the snow covered the roof of the orchard house, we gathered the last of the Coe's Golden Drop Plum, and smoked the house with bruised laurel leaves. It is of little use smoking such a house unless the roof is covered, and snow is the best of all coverings for the purpose. The snow and the frost prevented our collecting tree leaves, but we carried home a good lot previously raked up. For all sorts of hotbeds such leaves are invaluable, as requiring little or no previous preparation. We never scruple using rank dung beneath if we can put a good surfacing, say 12 to 15 inches, of hot sweet leaves over it.

Fine-Apple plants in pits and frames heated by fermenting material, cannot now be too well banked-up to the wall-plates, or the tops of the frame. For this any sort of heating material will do, as the object is less to give bottom heat than to throw heat, and dry heat too, into the atmosphere of the pit. Where there is plenty of manure, great things may be done by surrounding a solid wall with such material; then there is no danger of rank steam. If atmospheric moisture is wanted in the shape of vapour, all that is required is just to sprinkle the wall inside gently. The best pit we ever tried for heating in this way had slabs of stout slate 1 inch thick and 3 feet wide inserted in the brickwork. From rank fiery dung we have had these slates so hot that we could scarcely touch them. The next best was a solid 4½-inch brick wall in cement, with 2-inch piers at every 4 feet. From that pit, 5 feet in width, we could always obtain heat enough for anything, but in the winter the moulds of fermenting material against the wall were anything rather than narrow and small. We put a strong lining the other day against the back wall of a pit with late Cucumbers, to help the hot water. Such heating by dung is, no doubt, old-fashioned, but much might be done in this way in many a farmyard where the heat given off by fermentation is lost.

Another point is apt to be overlooked by many new beginners in the management of either cold or heated brick pits, and that is that the walls of such pits are good radiators of heat, and therefore carry away much heat in winter. We have known glass so carefully covered that no frost could enter, but cold and frost penetrated by the walls. It was like shutting the door securely and leaving the window unfastened. Where such places are well heated, the fuel plentiful, and the expense never considered, the walls, though 1 or 2 feet in height at back, need not be much thought about; but when matters are the reverse, and every bushel of coal is an object, then the placing from half an inch to an inch of wheat straw neatly with strings and nails against such walls would be a great saving as respects keeping heat in. Straw is scarce this year, and as yet our cold pits and heated pits are still exposed, but even in heated pits when we covered the back wall we soon saved the value of the straw in the diminished consumption of the fuel. When people have proved such things by experience they will be led to gain a similar object with much less trouble by having not solid but hollow walls, the confined air acting as a non-conductor.

ORNAMENTAL DEPARTMENT.

Out of doors the frost and the snow have had it their own way, and there has been little done except in sweeping walks for locomotion and clearing off prunings, &c.—R. F.

TO CORRESPONDENTS.

Books (A. T.).—There is no book with merely lists of plants for small greenhouses and small stoves. We have frequently published such lists in this Journal. Refer to back numbers. "Eden's—'Allotment Farming for the Many'" will suit you. If you enclose five postage stamps with your address you can have it from our office free by post. (H. T. S.).—You can have "The Cottage Gardeners' Dictionary" free by post for 7s. 2d.

Sand from Glass Works (T. R.).—The sample you enclosed is equal to the delicate silver sand for potting purposes. There is little, if any, plant nourishment in such sands, and they are only used either to render the soil with which they are mixed porous, or to secure a dry surface.

Gas Stove (Anthony).—Apply to any gas-fitter. We know of no grass needed for the purpose you mention.

VIOLETS NOT FLOWERING (E. M. S.).—Their not doing well is a result of their not having a proper amount of air and light during the summer, and when they are allowed to grow into a thick, close mass the plants are weak, and suffer from dryness in summer. Watering with liquid manure would not now induce flowering, though it would assist the swelling of the buds. You are right, Violets ought to be raised every year; the runners being planted in May in beds of good rich soil, watered well in dry weather and kept free of weeds, &c. If the old plants are retained they should have the runners, and, to a certain extent, the suckers removed, encouraging them with copious waterings in dry weather, and top-dressings of rich soil or well-rotted manure.

KEEPING MICE FROM BULBS (Rev. C. H. P.).—We cannot say where this powder is to be had as a protection to bulbs from mice. A line of tin will keep them away so long as the tar is offensive in smell and soft and liquid. Copped furze is greatly detested by them, and so are rough, larly awns obtained after threshing. Trapping and poisoning are so far efficient when mice are not otherwise well led. On the whole, there is nothing like a cat for keeping a place free of mice. On a border a cat might have a house at each end, with a wire all the way, connected with a con string and short chain round her neck.

CUCUMBER LEAVES INJURED (A Young Gardener).—We found a few red spots, and traces of blight on the leaf of the Cucumber. For the first, the best remedy at this season is painting the heating material when not above 100°, with sulphur, also painting the walls and other surfaces, and giving slight syringings in sunny days. For the latter, smoke will do best. The treatment is all right, but light soil and little dung will be best in winter.

TREES FOR A BANK OF LOOSE CHALK (Crete).—The bank being covered with soil for planting the trees, we do not see why Beech should not grow. Larch we have seen doing well where, from the stony character of the ground, most other trees refuse to grow. We should try both; the Beech to remain and the other as nurslings.

VARIEGATED PINE APPLE FRUITING (W. S.).—It is not unusual for this to fruit. We have seen fruit of from 3 to 4 lbs. weight, and we have no doubt under good cultivation it might be grown to a greater weight.

PLANTS FOR GREENHOUSE DECORATION (H. S. C.).—Six *Asclepias*, Stella, Criterion, Extranei, Mrs. Duchesse Adelaide de Nassau, and *Gleditsia formosa*. Six *Shorea Patersoniana*: Archibishop, Charles Turner, Maid of Honour, Expectation, Congress, and Conquillor. Six *Ficus Patersoniana*: Belle of the Season, Fairy Gair, Pink of Perfection, Lady Dorothy Nevill, Neatness, and Brightness. Twelve *Zonal Patersoniana*: Advancer, Charming, Coleshill, Diamond, Display, Harmony, Landscape, Mahel, Parity, José, Hope, Herald, and Estacy. Six *Douglas Poinciana Patersoniana*: Conqueror, Marie Lemoine, Le Vesuve, Delight, Sparkhill Beauty, and Mignon.

VINERY-GREENHOUSE (S. H.).—We approve generally of the plan and arrangement of the house, but, if suitable otherwise, we would have had the flue under the front table platform instead of under the back stage. For the late house, where you will not put many plants until the fruit is out, we would have the following—two Bowwood Muscat, one Trebbiano, two Muscat of Alexandria, two Lady Dow's. For the intermediate house—one Golden Champion, two Muscat of Alexandria, one Muscat of Hamburg, two Black Hamburg, one Trencham Black. For the early house—two Black Hamburg, one Royal Muscadine, one Buckland's Sweetwater, or Dutch Sweetwater.

GROUND VINERY (Howard).—We are not quite sure if we understand you. Do you propose that your brick wall, 24 inches high and 24 inches wide, flat on the top, should, with ventilating bricks at top, form the back of a Rendle's ground vinery, with another wall in front? then there can be no question as to the success. But if you mean the flat top of this 24 inch wall to be the base of your vinery, then we should prefer a wooden frame with glass to stand on it, as the use of bricks for the side would occupy too much room. The bricks beneath would absorb and give out heat in summer. In such a shady soil we would see no use in bricking in a little pit for the Vine roots. Any fresh, sweet loamy soil would do, and if you added a fifteenth part of boiled bruised bones, the same of lime rubbish if the soil was not naturally light, and as much sweet rotten dung, the Vines would grow freely in it. For a Vine to cover from 9 to 12 feet in length, a root space a yard square and 24 inches deep would be ample at first, as you could give rich top-dressings every year, and when you thought it would do the Vines good you might add a little more space of soil afterwards. We think that a small hot-water pipe in such a place would take a good deal of trouble, and be so far a departure from simplicity. If carefully attended to it would be useful in dull weather when the fruit was setting, and in dull weather in autumn when the fruit and wood were ripening. Cast-iron gas-pipes, however, we should think would be cheaper than those made of wrought iron.

VINES FOR A SMALL HOUSE (H. C.).—Your house, 20 feet long and 12 feet wide, will hold ten Vines at 3 feet apart, the two end Vines being planted 15 inches from the ends, and the distance equally divided between the others. We have a house of the same length with twelve Vines, but we think them a little too close together, for though for the first two or three years they have plenty of room, yet when the rods are spurred the whole length there is too little space for the leaves being exposed to light and air. You do not say whether you have other houses, and wish this to afford an early, midseason, or late supply of Grapes; but we take it for granted that you have no other house specially set apart for Grape culture, and our selection is made accordingly, and is—one Black Champion, one Frankenthal, two Mill Hill Hamburg, one Buckland Sweetwater, one Foster's White Seedling, one White Frontman, one Black Alicante, two Muscat of Alexandria, and if you have twelve Vines—one Lady Down's and one Madras-Bird Court Black Muscat. With these varieties in one house you may have a supply of Grapes till after Christmas. We approve of your having the Vines planted inside, having the border partly in and partly outside the house.

DUST FROM STOVE FIREBRICK (Poplar).—The dust you complain of as settling on your plants from removing ashes, &c., may easily be avoided by damping the ashes before you remove them, and damping the firebox before you clean it out. If the plants are very dusty we would take them out, or to a shed, in a fine day, brush them carefully with a small hair broom, and then syringe and wash them, and when becoming dry replace them. This would be better than washing them in the house.

HEATING A GREENHOUSE (G. D. Garis).—We would much prefer 34 or 4-inch pipes for heating your greenhouse vinery to 6-inch pipes. The latter will, of course, hold heat longer, but they will be lower in being heated. For such a house 14 feet in width, 6 feet in front, 8 feet at back, and then a hip of glass to the ridge, two 4-inch pipes along the front would keep out frost, and enable you to have good late Grapes, and to keep them hanging late. To have early Grapes, say in June, you would require four pipes instead of two—that is, three flows and one return. The "Vine Manual," which you can have from our office for thirty-two postage stamps by post, will, we think, suit you.

ENDIVE BLANCHING (R. S.).—The objections to using sawdust for covering and blanching Endive are, first, the trouble of washing the sawdust off, and, secondly, the taste that in some cases might be communicated; otherwise the plan would answer well. There is nothing better for blanching than a tile, a slate, or a board laid flat on the Endive plants, but in severe weather the plants beneath might be injured. It is merely as protection that leaves of straw above the slates were spoken of. Anything that will keep the plants from light will do. Nothing does better than a dark cellar.

LARGE POTATO (T. P. Smith).—Three pounds and twelve ounces is a great weight for a single tuber, but you will see at page 350 one mentioned that weighed four pounds.

WIRES OF TRAILING BREAKING (Alpha).—We fear you have no alternative but to remove the small brass wires and replace them with others of galvanized iron, which is the best and most durable for out-door work. Copper wire is little better than brass; it corrodes, and soon becomes brittle. No. 10 galvanized iron wire is what we use. It answers admirably, and is strong without being unsightly.

OROBANCHE ON CISSUS DISCOLOR (Duckwing).—The parasite you enclosed is *Orobanche minor*. It was introduced probably in the soil employed for potting the *Cissus discolor*.

BOILER FOR GREENHOUSE HEATING (R. H. F.).—As you obtain such an abundance of heat, we would let well alone. The sudden cooling of your house may be owing to the quick cooling of the 40-foot flue and return of small pipes before they reach the larger pipes in the house, especially if these small pipes are exposed, or close to an absorbing, conducting medium. They should be placed in a wooden box packed with charcoal or dry sawdust. We have not worked it, but we have no doubt the tubular self-regulating boiler is good, though we take all these wondrous descriptions with a considerable reduction. More depends on the stoker than on the boiler. See what is said on the subject in page 466 of the present number, the use of the damper, &c. With the right use of the damper, practice will soon teach you how to avoid trouble at night, and yet maintain a somewhat regular temperature. When the house is at its proper temperature, slow combustion regulated by the damper and the ashpit-door, will keep a regular heat for a long time. Recollect that heating a dwelling-house is very different from heating a plant house, where the glass is exposed to every variation of temperature. In a case similar to yours, the small saddle boiler was so close to the bars there was not room for fuel. Under-pinning with a fire brick so as to make the furnace larger made all right.

SHADE FOR FLOWERS (A. G.).—The simplest and cheapest is this:—Fig 1 represents a piece of pasteboard (old hat-boxes will be quite as good), about 8 inches by 6, less or more. By bringing the two bottom corners together, so as to overlap a little, the pasteboard can be nailed

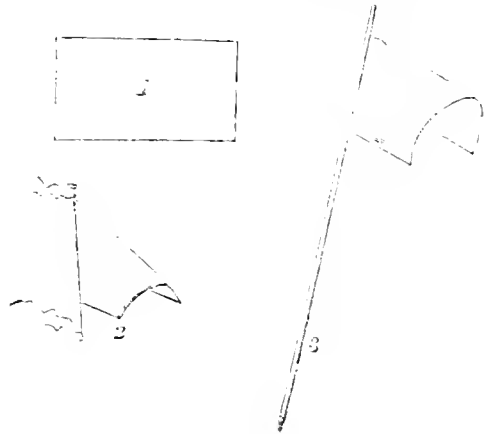

top and bottom to a thin lath of wood, as in fig. 2, which can be tied at the required height upon a tall flower-stick, which should be squared a little to make it set firm; or it may at once be tacked to the stick as shown in fig. 3. These shades will endure heavy rains if the pasteboard be moderately stiff, and will last several years. They have been used for Tulips, Ranunculuses, Carnations, Roses, Pinks, and Dahlias.

FUCHSIAS FOR STANDARDS (H. S. C.).—Avalanche, Beauty of Kent, Enchantress, Giant, King of the Stripes, and Troubadour.

AZALEA LEAVES FALLING (Julia).—We can only account for the leaves falling from its being their natural season to do so, or from their having been attacked by thrips, or from want of water in summer. The only preventive is to place the plants after flowering in a moist warm house, as a vinery at work, to make fresh growths, and, when these are formed, to keep the plants in a moist and warm atmosphere until the shoots begin to thicken at their points; then expose them fully to light and air, removing them to a cool airy house where they can have air day and night. The plants ought not to be allowed to suffer at any time from want of water, but they ought not to be watered whilst the soil is wet, yet water should be given before the soil becomes so dry as to cause the leaves to fall.

CAMELLIA BUDS FALLING (H. H. R.).—The principal cause of this is defective root action. It may be induced by a saturated and sour state of the soil, also defective drainage, but in your case we think it is caused by the regular waterings. Camellias ought not to be watered until the soil becomes dry, and then enough water should be given to show itself at the drainage. Pot them in spring in a compost of turf pared off a pasture or common where the soil is a light sandy loam, chopping it up small, using it fresh, and potting finally. We think they will not fall another season.

GRAPES SETTING (J. Mackenzie, M.D.).—All the Grapes you mention are good setters. We have never heard that Golden Champion does not set well. On the contrary, we believe it does; but the information you have received is correct, that the berries are in some cases attacked with a disease from which they decay prematurely.

HEDGE FOR MARKET GARDEN (Constant Reader).—Beech makes a very good hedge, but Hornbeam makes one thicker, and is the better of the two for a boundary, but we do not consider either of them formidable enough for a boundary fence. Holly and Thorn make the best of all. One Holly and five Thorns per yard will be required, and you may have a fence in three or four years that will turn anything, and from the growth of the Holly you will have a semi-evergreen fence second only for protection to Yew. We would not have the Poplars nor any kind of tree, unless it were a line or two of Austrian Pines, but for a market garden we consider hedges most suitable. Besides the boundary fence, we would divide the interior into quarters or plots by hedges of Beech and Hornbeam—that is, if the space is large; if but small, the boundary fence will

be sufficient. Trees are more injurious than beneficial, for their roots and branches waste too much ground. The best plan of breaking up the ground is to trench it as deeply as there is soil of a good staple, not bringing up too much of the poor stubborn subsoil. Trenching will cost more than, perhaps, any other mode of breaking up, but it will more than repay the first cost, and give a far better result than any other mode. Indeed, without deep cultivation the full value of the ground is not derived.

SOWING PELARGONIUM SEED (*A Subscriber*).—Sow the seed in pans or pots filled to within half an inch of the rim with light rich turfy loam, adding about a third of leaf soil and a sixth of silver sand. The pots or pans should be well drained, and the seeds scattered evenly and moderately thinly, just covering with very fine soil. Place the pots near the glass in a mild hotbed, and water gently and very carefully, and when the plants appear admit air freely. Sow in February or early in March. The main points to be attended to are free air-giving, keeping close to the glass, careful watering, but preserving the soil in a moist state, and keeping the seedlings from becoming drawn up. When they have made a rough leaf and show the second, pot off singly, and when again established remove them from the hotbed to a cold frame, hardening off, and either planting out or growing them in the greenhouse.

VINE BORDER MAKING—VINES FOR OUTSIDE BORDER (*Idem*).—The drainage of the border should be good. Nine inches to a foot of rubble will not be too much, and the bottom of the border should incline to the front, where there should be a drain to carry off the water. The border should be formed of turf taken from a pasture where the soil is a good light loam, prying it off not more than 3 or 4 inches deep. To every cut-load add two barrow-loads of lime rubbish from an old building, the older the better, and a barrow-load each of lumpy charcoal and bones broken and bruised rather small. The turf should be chopped into 3 or 4-inch squares, and the whole well mixed. Placing a layer of sods grass side downwards on the drainage, make the border of the above compost to the depth of 3 feet, and we would have it, if practicable, fully half above the surrounding ground level. For planting the Vines use a compost of two six-months old chopped small, adding a fourth of well-rotted manure and a sixth of half-inch bones. The best time to plant is early in March, just when the Vines are beginning to push or have started into growth. The kinds succeeding best in an outside border are Black Hamburg, Frankenthal, Mill Hill Hamburg, Trencham Black, Foster's White Seedling, Buckland Sweetwater, and Trovrien Frontignan. The Muscats and late-hanging kinds, requiring as they do fire heat for their successful ripening, are not, as a rule, suitable for outside planting.

FUNKIAS, SEEDLING CANNA, AND WIGANDIA TREATMENT (*H. S.*).—The Funkias should be kept moderately dry until they grow, the soil not, however, being kept dust-dry; when they commence growth water copiously. They are increased by division of the roots when the plants are beginning to grow. Keep them in a cold frame, pit, or cool house with abundance of air and light. They are, however, hardy. We think the cause of the seedling Wigandia losing their leaves now is their having a drier atmosphere than they were exposed to during the summer. Give no more water than enough to keep the leaves from flagging, and afford a light situation. Report in March, and being encouraged with an increase of temperature and moist atmosphere, they will start freely, making nice plants by May, when they should be hardened off, and planted out in June in warm sheltered situations. The seedling Cannas are all right. At this season the old stems die down, but the roots are alive. Keep the soil dry, or give very little water. They may remain in the pots during the winter, and in February or early in March shake them out, report them in fresh soil, and place them in a hotbed, watering carefully until they begin to grow, and when they have grown a foot or more height take a off. They are fine either for the greenhouse or sheltered spots in flower gardens.

NAMES OF FRUITS (*J. M.*).—No. 1, Beurre d'Arcambert; 2, Passy Colmar; 3, Easter Bourne; 4, Winter Cassano; 5, No Plus Morris. *(J. E. Rind)*.—Passy Colmar. (*J. B.*)—1, Triomphe de Joubert; 2, Gloire d'Orléans; 3, Swan's Egg; 4, Golden Water Pearmain; 5, Margil; 6, Hollandbury; 7, Golden Noble; 10, Northern Greening; 11, Hughes's Golden Pippin.

NAMES OF PLANTS (*T. H.*).—1, Blechnum bra-siliense; 2, Campylopusium phyllitidis; 3, Aspidium ciliatum; 4, Nephrolepis molle; 5, Pteris caudata Sieboldii, now Lactaria Sieboldii; 6, Cyrtidium Fortunii; 7, Selaginella Kraussiana (the *S. hortensis* of gardens); 8, Adiantum cucullatum; 9, Adiantum trapeziforme; 10, Adiantum macrophyllum; 11, Lycopodium vesperitidis, or Pteris incisa. (*Buell*).—1, Tradescantia vittata; 2, Begonia fuchsoides; 3, Mesembryanthemum, specific name next week. (*Lee*).—Your plant appears to be *Watsonia strictiflora*. (*J. B. Senebar*).—Your plant appears to be *Pentstemon baccharifolium*. (*H. B.*).—Both your plants are *Cineraria maritima*, also known as *Senebar cucuraria*, a common South-European plant, much used as an edging plant in gardens. (*A Subscriber, J. L.*).—Cultivated in gardens under the name of *Azteratum glaucum*, which name we believe to be spurious. (*G. B.*).—One is *Asplenium marinum*, the other a variety of *Lady Fern*, *Athyrium Filix-foemina*. (*J. W. Boyd*).—*Asplenium formosum*.

POULTRY, BEE, AND PIGEON CHRONICLE.

GOLD-PENCILLED HAMBURGHS.

In your criticism of the Birmingham Show you draw attention to the fact that the hens in the Gold-pencilled classes seem to be fast losing colour. I deem this fact of so much importance—if we are to arrive at perfection in breeding this beautiful variety—that I crave a few lines to point out a remedy. A few years ago I paid a visit to Yorkshire, and experienced no difficulty in finding several beautifully pencilled hens with a rich ground colour, yet this year very few of these dark birds are to be found. A very successful breeder of Pencilled Hamburgs in the eastern counties writes me—“Have you another good pair of pullets to part with . . .

as I have been unfortunate in breeding them this season?” I get the same tale from Yorkshire, Lancashire, and Northumberland, and yet to my mind there is no variety of fowl so easy to breed as Gold-pencilled Hamburgs. If exhibitors will only adopt the advice given in our poultry books, they will experience no difficulty whatever.

Having been asked to contribute a few lines to your Journal on the result of my breeding experience, I do so in the hope that it may induce lovers of Hamburgs to exercise more care in the selection of their breeding stock. I attach more importance to the colour of the cock than to the colour of the hen, provided, of course, the hens are finely pencilled. This season I bred with two hens, a pullet, and a three-year-old cock with a bronze tail. The result was very indifferent pullets, well pencilled, but very light. With the same hens and a dark-tailed cock—in fact, I should say a green-tailed cock, I bred pullets three or four shades deeper in colour, and this I am persuaded is no accident. Season after season I have bred pullets an exact *fac simile* of the hens I have bred from, in pencilling, ground colour, and comb, but I have invariably found that the depth of ground colour in the pullets was in proportion to the depth of colour in the male bird.—FRED. PENNIX, *Whitmead House, Ashley Vale, Bristol*.

ARMOUR-PLATED POULTRY BASKETS.

When will the cares and troubles of poultry exhibitors cease? It is now just four years ago that my old Light Brahma cock Sampson, well-known to many of your readers, closed his victorious career so tragically, being killed on his way to a show by the bite of a dog. History is said to repeat itself. Last week my first-prize Birmingham cock, also a winner of many prizes, returned home, having narrowly escaped old Sampson's fate. His basket was torn and shattered, his feathers lay in considerable numbers on the floor of it; two wounds, the larger about the size of a thumb-nail, most fortunately not deep, were visible under the feathers on his back. Altogether, the bird looked much the worse for the fright and the shock to his system. Restoratives in the shape of bread and ale, and a few hours' rest, improved his appearance considerably, but, although well enough to go to the Crystal Palace, he certainly did not exhibit his “Birmingham form,” and his first prize at the last-named show degenerated into a simple commendation at the Palace.

I think your readers will agree with me that so narrow an escape from a great catastrophe, even assuming no worse thing to happen, is not a pleasant possibility for an exhibitor to contemplate every time that dogs and poultry are fellow travellers to or from a show.

I may add that mine is not a solitary case, as another exhibitor tells me of a similar accident on the very same occasion. What, then, is the remedy? One expedient has occurred to me, which I mention for the sake of its being possibly useful to other exhibitors. I have commenced the construction of some “iron-clads” or “armour-plated” baskets. In other words, I have told my blacksmith to fix inside two or three baskets intended to carry my most precious specimens, when liable to canine danger, a lining of perforated zinc or tin, with apertures sufficient for breathing purposes, thus protecting the sides and bottom of the basket from hostile teeth, and rendering its occupant as philosophical as the poet of our infancy, when he said—

“Let dogs delight
To bark and bite.”

—JOHN PALES.

LA FLECHE FOWLS AT THE BIRMINGHAM SHOW.

In the account of the Birmingham Show, in your paper of Thursday, December 1st, the following paragraph occurs relating to my La Fleche hens which took first and second prizes:—“The hens were in better order, but the second prize was a manifest error, being half-bred with Minorcas. This was evident all over, the birds having Spanish bodies, red faces, and one an actually flapping comb.” I should be much obliged if you would contradict this statement, as it is calculated to do me serious injury. The birds referred to I bred at Westworth myself from others also bred by me the previous year; and I have never had either Spanish or Minorcas in my possession, nor have any of my La Fleche ever been crossed

with any other kind of fowl.—W. C. W. FITZWILLIAM, *Wentworth Woodhouse, Rotherham.*

THE BIRMINGHAM POULTRY SHOW.

THE yearly show at Bingley Hall has now passed through more than three generations. It is at that ticklish age for some part of creation that is described by being between twenty and thirty. As it gets older it increases its claims upon us, and shows more and more it is carrying out the purpose for which it was started. Those who assisted at the beginning will recollect how a sort of apology was considered necessary, and it was therefore put forth that its object was the improvement of the breeds of domestic poultry. Had there been another—the introduction of new breeds, it would have been attained. The improvement has been an increase of weight, till Ducks now weigh nearly as much as Geese did formerly, Geese half as much again as they did, Turkeys as much as some of the smaller quadrupeds, and fowls as much as hen Turkeys. It has introduced Brahmas, Creve-Coeurs, Houdans, La Flèche. It has made Game Bantams. It has formed, as it were, a table that can be depended upon, showing the fowls that are fit for certain soils, that are calculated to satisfy the requirements of certain amateurs. It describes those that thrive in close confinement, or require the run of a farmyard. It has shown that poultry may be a profitable adjunct to the stock of the agriculturist, and a pleasing relaxation to the professional man, while it is also self-supporting.

Those who have the management and ordering of this great Show have no cause to complain of the public; they have been well supplied, and they deserve it. Many years ago a pen was composed of a cock and three hens or pullets. It was said that only those who had large stocks could pick out four birds good enough for exhibition. The pen was then altered by a cock and two hens. It was next said if anyone wanted to buy a cock he was obliged to buy two hens at the same time. Then a class was introduced for cocks only. This was a success—so great, indeed, that now all the classes are altered, and buyers may secure either a cock, or two pullets, or two hens. Then it was objected that there was trickery in claiming the most profitable pens on the opening day. It was necessary to squeeze, and almost to fight, for two or three hours to ask for a pen, and find it already sold. The owner of a very good bird rewarded with a first prize, who had been so doubtful of its merits that he only named a small sum, at which it was immediately obtained, sold and resold four or five times till it had ten times the sum originally put upon it, is now sold by auction at midday, and the owner gets all the advantage of it. These are only some of the endeavours made by the intelligent and hard-working Council and Committee to deserve the support they receive.

I will now take a review of the different classes, making, in going on, such remarks as may suggest themselves.

Two hundred and ninety-four pens of *Dorkings*; almost a show in themselves. Many of our old names were among the exhibitors and prizetakers, and many new ones, some distinguished for the first time. I can no longer note an increase in weight. It is, perhaps, unreasonable to expect that every year should produce heavier birds than its predecessor. Where would they stop? This year the prize cocks weighed from 10 to 12 lbs., and hens and pullets from 8 to 10 lbs. each. The weight that was the desideratum some years since is now so much of a fact it calls for no particular comment. But it must not be supposed I am frating the classes to "faint praise." Seventy-three pens were named in the prize and commended list.

Three hundred and twenty-two entries of *Cochin-Chans*, sixty-nine of them named honourably by the Judges. I cannot speak too highly of these birds; the offer by amateurs of four silver cups and the same number of extra prizes of 25 each, may have had to do with the beautiful display these classes afforded. Mrs. White's adult cock, and Mr. Augustus Taylor's bird of 1870, were most perfect specimens of the breed, and reminded me of Mr. Tomlinson's celebrated bird some years since. If I were to speak critically of these classes I should place the Buff first, the White second, and the Game last. There were perfect hens and pullets of the first—positively perfect. The Whites were excellent, many of them having but one drawback—the vulture hook. I should place the Game last; they have size and symmetry, but many of the hens and pullets are too yellow in their plumage.

Indian Pouter, a comparatively recent introduction, brought two hundred and sixty pens of noble birds. Two silver cups, extra prizes, belonged to these classes. One went to a beautiful bird of the year, shown by Lady Gaydyr; the other, for two pullets, went to the Hon. Mrs. Baillie Hamilton. I cannot speak too highly of many of the birds that competed in these classes. Mrs. Hunt's birds were beautiful; the Hon. Miss Douglas Pennant sent excellent specimens. In some of the pens vulture hooks cast away prizes, and in some of the hens there was a buff tinge that is not desirable. The Light variety now forms large classes, and supplies beautiful birds. Mr. Pate (the father of the classes) of course took one first prize, but the silver cup was taken by Mr. Cook. Another first prize was taken by an old exhibitor, Mr. Richard Rollard. A great success was achieved by Mr. W. Sampson, of the United States, who took prizes for cock and hens. I hope this is only the beginning of competition on the part of our transatlantic friends. I can speak very highly of all these and many others.

Spanish were very well represented, but with the exception of some few pens they were hardly so good as I have seen. I was glad to miss some of those monstrosities with cauliflower faces and closed eyes. There were not wanting beautiful specimens of both sexes.

The *Game* fowls were represented by three hundred and seventy-four pens. These, if alone, would have constituted a show, and the number of good birds shown make it impossible to attempt anything like a mention of all that deserved it. I can speak favourably of all the prize and commended birds, more especially the Black and Brown Reds. The Duckwings are among the weak classes, and I missed the splendid bird I saw years ago. The Silver Duckwings seem to be almost lost. I am sorry for it, for I knew no handsomer birds.

Bantams have suffered a revolution of late years. Of one hundred and seventy-three pens, no less than one hundred and sixteen were contributed by the Game. The beautiful Sebrights only brought thirteen pens; many of the birds were highly meritorious, and if pens could have been made irrespective of ownership, perfection would have been the result. In the varieties I greatly admire the Pekin, or, as I call them, Cochin Bantams. If the Japanese increase but a little in numbers they must have a class. The Game, especially the cocks, were very good, and formed a most attractive class. I must, nevertheless, offer one suggestion to exhibitors, which is to select birds with wings close up to their bodies. However meritorious the drooping wing may be in a Sebright, it is a serious fault in a Game Bantam.

The points of *Aylesbury Ducks* are so well known, that I shall content myself with giving the weights of the successful. Of the four prize pens the first weighed 18 lbs. 9 ozs., the fourth 18 lbs. 4 ozs. There was an unexampled show of *Rouens* of seventy-two pens. Not only were the prizetakers faultless in colour, but they were heavier than the *Aylesbury*. The first-prize pen weighed 19 lbs. 1 oz.

The *White Game* held their own. The first-prize pair weighed 56 lbs. 12 ozs., the second 56 lbs. 5 ozs.; the goslings of this year 49 lbs. 4 ozs., and 49 lbs.

The first-prize adult *Turkey* cock weighed 36 lbs. 4 ozs., the second 35 lbs. 2 ozs. Both the prizes for cocks of 1870 went to Mr. Lythall, the birds weighing 24 lbs. 6 ozs. and 23 lbs. 12 ozs. The old prize hens weighed 35 lbs. and 34 lbs.; the young ones 31 lbs. and 29 lbs. I most heartily congratulate Mr. W. Simpson on his success; he beat all competitors with a bird that came across the Atlantic to compete.

I deserves mention, and should speak a trumpet-tongued warning to exhibitors, that many of the best birds were passed over because they were timmed. Had those birds not been tampered with they would have taken prizes.—VIVANT.

TRIMMING PIGEONS.

"Y. B. A. Z." complains of gross cases of trimming (I presume in poultry), and makes use of the following sentence:—"It is, however, certain that the usual washing and cleaning of some birds before exhibition makes it very difficult to draw a distinction between the removal of a soiled, half-broken, or injured feather, which I imagine all of us would consider admissible, and the removal of a blemish, or the painting over such a spot. I should much like to learn whether any exhibitor does consider this illegitimate." As a Pigeon-fancier, breeder, and exhibitor for the pure love of the thing, you will, perhaps, permit me to express the decided opinion, that to trim a Pigeon for the show pen, or before sending it on approbation, is nothing else but—a swindle. Judges have been swindled by it, and so have exhibitors and purchasers; some of them myself among the number, innumerable times. Not long since I bought a Red Jacobin cock at a good price from a man in Yorkshire, who boasts that he writes against trimming in a certain journal, and I did so only upon having a sight of the bird, which appeared to me to be a perfect beauty, and without a foul feather. Imagine my surprise when in one month every third feather on his head was red. I kicked up a row about it—of course I did—when this fancier, known to every reader of "our Journal," coolly told me that he had only had the bird for two days, and it it was trimmed he, a protector against trimming, was not responsible for it; and when I told him that the bird was not worth sixpence to me, he coolly offered me a shilling for it. I suspected some other fancier might get the bargain and repent it, so I pulled the bird's neck; but I think I was swindled, and I object to be swindled. Upon another occasion I purchased a pair of Black-headed Nuns from a gentleman fancier, who honestly told me they required a *little* trimming. I wished to have them because I knew that he had taken seven first prizes, and I paid for them accordingly. The seller said rightly they only required a little trimming, because the cock had only one black feather on his breast, and the hen two between her shoulders. I lent them four times to fanciers, who saw nothing wrong in extracting these three feathers, and the birds always brought the first prize. I showed them nine times with the three foul feathers where Nature placed them, and they never brought me even honourable mention, with the exception of once at Kilmarnock, when they

were placed "first" by Mr. Hale against birds which had beaten them fourteen days before. One of the shows to which I went them was held at the place from which I write, and they were beaten by a pair of birds pure as the driven snow at the show, but when they were ten days in the loft of a gentleman who claimed them, they had a strong likeness to a Silver-spangled Hamburgh.

Well, sir, as I would not dress, I sold, and these birds are now the property of a fancier who considers them the best pair of Nuns in the world. I never knew them beaten except when I had them, and they were as good then as ever they were or can be. I state these facts as my experience of trimming, and I would say it is a disgusting practice.

I would suggest that the prospectors of our shows should not only contain a prohibition against trimming and painting, but that where the judges find out that birds have been doctored, they should be empowered to confiscate the whole pen, and in cases of strong suspicion keep possession of the birds for a reasonable time to make certain. Unless some strong measure like this be adopted, true lovers of Columbia will keep their pets at home rather than be quaked out of their due by those who trim or employ professional bird-stuffers to do it for them. Perhaps you do not believe there are men who live by trimming birds for other people by the job; if so, you are mistaken, because I know one loft where, before every show of importance, there is to be found a professional man, who comes expressly to dress exhibition birds, and is well paid for it. He can insert as well as extract, blacken, whiten, and roll on, or do almost anything an ill bird requires to make it look a good one, and he does it well. It is not honest, however, and I uphold that to pull out a feather is the same as to put one in—that is, it is—a swindle.—E. M. B.

KILMARNOCK ORNITHOLOGICAL SOCIETY'S SHOW.

The nineteenth Exhibition of this Society was held in the Corn Exchange Hall and Bazaar Market, Kilmarnock, on the 29th of November, and was more successful than any previous show. The entries for poultry numbered 521; the Pigeons 211; the Canaries, Males, Goldfinches, and other birds, 202, nearly all of which came forward, there being very few empty pens.

Spanish (16 pens), was decidedly above the average. The first prize went to a pair of fine birds, the cock also winning the silver medal offered as a special prize to the best cock or cockerel in the class. The second prize pen contained a very superior cock, but the hen was scarcely equal to him. Miss Crawford exhibited a very superior single cock shown for the medal, and Mr. Stuart's commended pen contained a most excellent hen but badly matched. Dressing the faces in this class obviously did not disqualify, as certain of the winning birds were most beautifully done. We, however, think it would be fairer to the general body of exhibitors if judges could either rigidly disqualify all such birds, or sometimes state in their schedules that removing hairs from the face and feathers to the furthest limit of the white would be admitted.

Pouter (15 pens), were a fair class. The first-prize pair were large and well matched, the cock being a little deficient in comb. He would, however, have easily secured the tinopiece offered for the best cock or cockerel in this class, but was unfortunately not entered for it. The third-prize pair were most excellent Silver-Groys, this cock being awarded the tinopiece.

Brahmas or Cochins (18 pens). Thirteen Brahmas and five Cochins; but notwithstanding the disparity in numbers the Cochins succeeded in carrying off the bulk of the honours, securing first, third, and fourth, and a commendation, while the Brahmas had to be content with a second prize and high commendation. The Brahma cock in the second-prize pen was probably the best bird in the class, but matched with a hen good in colour and marking, yet not too small.

Scottish Geys.—This, although somewhat a hard breed, did not muster more than fifteen pens, of which the first and second-prize pens were remarkably fine specimens. The second-prize cock had as finely a marked tail as we ever saw, being entirely free from either black or white feathers. He was, however, deficient in size and shape as compared to the first-prize bird, which also gained the tinopiece for the best cock or cockerel in this and the preceding class.

For the benefit of English fanciers we may here state that this class of birds are coloured exactly like Cuckoo Dorkings, and are, indeed, esteemed the more the nearer they approach the Dorking type in everything but the number of toes, five being at present a disqualification. We think it would be much better to admit the five toes, and as the colour has long been, and still is, the favourite one amongst Scottish bantam fowls, to call them by the name of Scottish Dorkings.

Gold-spangled Hamburgs (23 pens), eight or nine of them being worthy of first honours at any show. The breed is evidently strong in this neighbourhood, as another local exhibitor secured the second prize, the third being won by Mr. Will with a splendid cock, but the hen very slightly deficient in marking.

Silver-spangled Hamburgs (23 pens), the class being decidedly superior to what it has ever been in former years. The first-prize cock was also awarded the tinopiece offered to the best cock of the Silver-spangled or Silver-pencilled classes.

Gold-top *Black Red* (21 pens), were a very superior class. We believe the equal of the first-prize hen has rarely been seen, and we have no doubt that she will score a few more prizes for her worthy owner.

White-spangled Hamburgs (12 pens).—In the first prize pen the cock was first-rate in head, tail, and style, and, had his comb not been slightly tinged with yellow, the tinopiece offered between the cocks of this class and the Silver-spangled must have gone to this bird.

Reducks.—Of these there were only three pens.

Game fowls (25 pens), the Brown Reds securing the whole of the prizes, being superior in shape to those of the other colours. The first-prize cock was in shape and style a perfect model of a Game fowl, but was slightly deficient in colour. He was, however, awarded the tinopiece offered for the best cock amongst the Polish, Game, and any variety classes.

Blue *Bantams* (22 pens).—The tinopiece offered for the best cock or cockerel in this class was won by an excellent Black Red, but he was matched with a hen so inferior in colour and in general condition that the pen was not the prize intended in the prospectus. The first prize was awarded to Mr. R. B. and the second and third. We observed the cockerel in this pen had the comb white, but he was only sold, and he was scarcely in good enough condition to be so. We think the position of the type as would have been never so good.

Black and White Pouter.—The first prize was awarded to a very small pair of Blacks, excellent in colour and style, the cock also winning the tinopiece for the best cock or cockerel. The second prize went to Blacks inferior in colour to the first, and the third to very excellent Whites, which in the opinion of our parties should have been awarded the second prize.

Bantams of any other variety (10 pens), were mostly S. Whites. The first prize and silver medal for the best pair in the class were awarded to a pair of G. B. S. undoubtedly superior to anything else. If we mist do not, they were those which were first of Johnstone show a fortnight before, where they also attracted considerable attention. The second prize was awarded to Silvers, the third to Golden, and the fourth to Scotch Geys, which latter should be fast-birds of the breed, but of the same name, but we fancy we have seen better specimens.

Black-spangled Hamburgs.—The first and second prizes were awarded to Grey Chans, and the third and fourth to Black Hamburgs.

White Pouter (12 pens), excellent in quality. **White Ducks** (12 pens).

Black and white cocked (5 pens).—The Judge in this class was evidently inclined to encourage the useful more than the ornamental. Gills were first, Black East India second, then very third, and the beautiful Carolina only fourth and highly commended.

TIGONES.

On entering the Hall the first birds that met our view were **Old Dutch** *any colour*.—The first-prize pair (Blue) were fine birds, good length of feather and comb, the hen rather grey by arching. This pair of birds also carried the special prize for the class. The second-prize pair were well matched in colour and marking, though not equal in style to the former pair. Third prize, a pair of R. B. the cock in particular a very fine bird in splendid show. This class as a whole was good.

Bantams bred in 1870 (any colour).—A very good class, some pairs not well matched, but in every of the birds, particularly the cocks, showed great promise. The length of feather seemed to prevail, that of limb rather deficient.

Carriers (any colour).—This was the finest class of Carriers ever shown at this competition, and we have seldom seen a finer out of a city show. The first-prize pair were really grand birds; they also carried off the tinopiece (special prize). The second-prize pair were also fine, and the third prize was taken by a Kilmarnock breeder.

Game fowls bred in 1870.—A very fine class. Some of these birds were in point of form and elegance complete, both Blacks and Duns. Mr. W. Massey, who carried off the first prize in the old class, was also first in this. The two classes of Carriers were certainly the finest in the Show, besides those the largest.

Shrike-fowl *Taube* were a very good class. The first prize went to Alm onds, very fine though poor in colour. This pair ought to have also carried off the special prize, but, as they were not entered for it, the special fell to the second-prize pair, also Alm onds. In this class were a pair of very fine Kites and good Black Mittles.

Buffs.—A good class. A pair of Yellows took the first prize, and a pair of pretty Reds the second. Several pairs were ill-matched.

Reducks were a large and fine class. Excepting a pair of Black Saddlebacks all were pure Whites. The first-prize pair were splendid, the second and third very fine, and numerous pens contained fine specimens of both sexes handsly matched.

Jacobins.—A poor class. This breed does not seem to improve anywhere.

Turkeys were a good class. The first-prize pair seemed to have been birds lately imported. There were a number of pretty sweet-looking birds and well-marked, but, as at most shows now-a-days, too many having the skull crown instead of the pointed or turn crown.

Trumpeters.—An excellent class. The first prize went to a splendid pair of Mottles. The Whites were the only birds that fell short. We have seldom seen so many fine Trumpeters entered by so many different exhibitors. With two exceptions the crest, rose, and feet were up to the standard.

Nuns formed a good class; they looked well at the Show, being not only well marked but very clean.

Common Tumbler.—A pretty and varied class—Baldheads, Beards, Mottles, Sells, and a very pretty pair of the Blue-barred breed neat and small. We also saw in the Committee-rooms a very neat pair of Reds showing their tumbling properties to an intending purchaser, the hen in particular doing it clean and cleverly when called upon.

Common Pigeons.—A great array of strong handsome birds, and a great array of youthful fanciers trying to discover the difference between the successful and unsuccessful birds.

English Owls.—A pretty class. The first-prize bird was a good sample of what the Owl should be.

Any other distinct variety.—Not a large class, but containing a great variety. A pair of White African Owls carried off the first prize.

CANARIES, &c.

The prizes in this department were offered only to Scotch Fancy, which is most emphatically what Mr. Blakston calls it, "the bird of Scotland." In the eyes of Scotch fanciers it is the most elegant and graceful Canary in existence; and when we see Englishmen describing them as being nothing but bad Belgians, we generally have an attack of bile for a day or two. We see our revenge, however, as they are evidently invading the south, and we have little doubt will before long supersede some present favourites. We would, however, warn southern fanciers not to let them do what they have done in the north—viz., extinguish all the others, with the exception of Belgians. We are sorry to see of late years a disposition in Scotch fanciers to breed nearer to the Belgian than they used to do, particularly in the shoulder. The true Scotch Fancy shoulder should be shaped like a cone cut in two from the apex to its base, entirely free from the squareness seen in the Belgian; but in the award of the timepiece for the best clear bird in the Show we observed the winning bird (Mr. Conn's first-prize Buff cock) had the shoulder, if not so high as a Belgian's, at least decidedly of the characteristic shape. We should like to see prizes offered at this Show for Belgians also, which we think would have the effect of keeping breeders nearer to the genuine type, as the characteristics of both breeds would then become more generally known.

In Yellow cocks there were many excellent and true-bred birds, the first and second being very good. The Yellow and Buff winning hens were also very superior birds; and amongst the Pigeons were many beautiful evenly-marked birds quite up to the standard shape. In the Mule classes everything was cast into the shade by Mr. Gray's Yellow-marked bird; it was a perfect show in itself, so large and beautifully coloured; and in the Goldfinch class Mr. Conn's first-prize bird was equally conspicuous.

In the class for the best home or foreign bird only three Parrots went in appearance, though more were entered. The first prize went to a Green bird in the most perfect condition we ever recollect of having seen a Parrot. It could not have been smoother although cut out of solid marble. The second prize went to a nice light-coloured Grey.

We believe that in all the classes the judging gave very general satisfaction.

- SPANISH.—1 and Medal, A. Walker, Kilmarnock. 2 and 1/2, A. Robertson, T. Waddell, Kilmarnock. 3, J. Blair, Kilmarnock. 4, J. Dick, c. A. Stuart, Kilmarnock.
PENGUINS.—1 and 1/2, A. J. Mutter, Kilmarnock. 2, Z. H. Heys, Barrow, 1/2 and Timepiece, J. Gray, Airdrie. 3, G. F. Lyon, R.N., Kirkcubright. c. T. Seabrook, Kilmarnock.
CHINA BANTAMS OR COCHINS-CHINA.—1, G. Girdwood, Ayr (Cochins). 2, A. Robertson (Black). 3, J. P. Leck, Paisley. 4, J. Cochran, Kilmarnock. 5, A. Robertson (Black). 6, J. P. Leck, Paisley. 7, J. Gray (Cochins). 8, H. Fenton, Kilmarnock (Cochins and Redhead). 9, J. Gray (Cochins).
SCOTCH GREYS.—1, 2, and Timepiece, J. McKinnon, Hamilton. 3, R. Blair, 1/2 T. Wallace, Leamington. 4, A. Grant, Kilmarnock. c. J. Fulton, Bath.
HAMBURGERS.—Golden-splashed.—1 and Timepiece, J. Jardine, Kilmarnock. 2, A. Fritchen, 3, J. W. Will, Barrow. 4 and 1/2, R. Mackie, Kilmarnock. Silver-splashed.—1 and Timepiece, D. Gilman, Kilmarnock. 2, P. Mackie, 3, J. W. Will, Barrow. 4, J. Jardine, Kilmarnock. 5, D. Stewart, c. H. Pickles, jun.; 6, W. Mitchell, Golden-pencilled.—1, 2, and Medal, E. Crawford, Kilmarnock. 3, J. M. Campbell, New Byth. 4, W. Bachop, Stonefield, Linsay. 5, W. Nelson, Johnstone. c. J. Aitken, Girvan; J. Howe, Paisley. Silver-pencilled.—1, H. Pickles, jun., Barrow. 2, F. C. Haworth, Newfield, Haddington. 3, W. Bachop. 4 and 1/2, R. Blair, c. J. Platt, Dean near Bolton.
POLANDS (Tuppel).—1, H. Pickles, jun., 2, J. Partington, 3, J. W. Will, Barrow.—1 and Timepiece, J. McLaughlin, Paisley. 2, J. Barrow, jun., Pradley Field, Kendal. 3, Waddell, Airdrie. 4, R. Aronckie, 1/2 R. W. Will; Z. H. Heys, c. W. Young, Dalwhinnie.
GAME BANTAMS.—Timepiece, A. Gibb, Ayr. 1, Z. H. Heys, 2, Bellingham and Gill, Woodfield, Ayr. 3, J. W. Will. 4, W. Copland, Ayr. 5, T. Barker, Hill End, Burnley. c. J. Robertson, jun.
BANTAMS.—Black or White.—1 and Timepiece, J. W. Will (Black). 2, H. Pickles, jun. (Black). 3, S. & R. Ashton (White). 4, A. Mitchell, Paisley (Black). 5, H. L. Horne (White). 6, Drake (Black). c. H. L. Horne. Any other Variety.—1, and Medal, J. Crawford. 2, Miss F. C. Frew, Kirkcaldy (Silver-laced). 3, J. G. Orr, Beith (Gold-laced). 4, Mrs. Maxwell, Galston.
ANY OTHER DISTINCT BREED.—1, B. M. Knox, Riverside, Kilmorie (Crest-Crest). 2, Mrs. Hood, Greenbank, Ayr (Crest-Crest). 3, J. Fulton (Black Hamburgs). 4, J. P. Fawcett (Black Hamburgs). 5, G. F. Lyon, R.N. (Doulans). c. J. J. Maddow, Blythswood (Crest-Crest).
GREYS.—1 and Timepiece, J. Robertson. 2, W. G. Kerr, 3, J. W. Will. 4, W. Young, 5, A. Robertson. 6, J. Scott. 7, A. Gray. 8, J. W. Will. 9, W. Young. 10, A. Robertson. 11, W. B. Park. 12, J. Walker. 13, W. Conkey, Darvel. c. A. West, Wortsburn, Parady. Any other Variety.—1 and 1/2, J. Robertson (Call and Cardinal). 2, F. E. Scheffell, Morpeth (Black East India). 3, G. F. Lyon, R.N. (Muscovy). 4, S. & R. Ashton, Mottram (Cardinal). c. J. Dickie.
SELLING CLASSES.—1, W. Walker, 2, W. Jardine (Golden-spangled Hamburgs). 3, W. A. Orr (Golden-pencilled Hamburgs). 4, A. J. Mutter, Kil-

marock (Rouen Ducks); G. F. Lyon, R.N. (Brahmas); J. Sharp, Johnst. (Spanish).

PIGEONS.

- FOURNS.—Old.—1 and Timepiece, J. Butler, Glasgow. 2 and 1/2, J. Miller, 3, W. Archer, Kilmarnock. 4, G. Mann, Kilmarnock. c. J. Brown, Wishaw. Young.—1 and 1/2, J. Mitchell. 2 and c. J. Miller, Glasgow. 3, R. Aronckie, Parthen, Glasgow. 4, B. Donalson, Crosshouse.
CARVERS.—Old.—1 and Timepiece, W. Massey, Spalling. 2, H. Yardley, Birmingham. 3, J. Kerr. 4, M'Gill Skinner. 5, A. Wardrop, Kilmarnock. c. J. Guthrie, Hexham. Young.—1, W. Massey. 2 and 1/2, W. H. Mitchell. 3, A. Brown. 4, G. Brown; D. Munn. c. D. Lawrie, Kilmarnock. G. White.
TUMBLERS (short-faced).—1, J. Paton. 2 and Timepiece, J. Butler. 3, T. Deuch. c. J. Guthrie, Hexham. 4, J. Mair. c. H. Yardley.
DOVES.—1, H. Yardley. 2 and 3, White. 4, Miss E. M. Beveridge, Ayr.
FRANTS.—1, 2, and Timepiece, T. Wilson, Stewarton. 3, J. Kerr. 1/2, J. Sharp. 4, J. Galt, Kilmorie. c. W. Anderson, jun., Glasgow.
JACOONS.—1, J. Jardine, New Cumnock. 2, G. White, Ladyburn, Paisley. 3, R. Thompson, Beith. 4, A. Richmond, Kilmarnock.
TEMPERS.—1, Miss F. C. Frew. 2, R. Gibson, Kilmarnock. 3, W. McKindlay, Edinburgh. 4, R. Thompson.
TURKISH.—1 and 1/2, J. Hawley, Bingley. 2, G. Steele. 4, G. White. 5, Miss E. M. Beveridge. c. J. Sharp.
NUSS.—1, J. Reid, Darvel. 2, W. McKinnay, 3 and c. G. Gilchrist, Darvel. 4, Master A. Frew, Kirkcaldy. 5, J. Mair, jun., Kilmarnock.
TUMBLERS (Common).—1, Miss E. M. Beveridge. 2, W. McKinnay, 3, R. Blair. 4, Miss J. Weir, Kilmarnock. 5, T. Hawley. c. H. Craig; J. Guthrie, Hexham; J. Thomson, Kilmarnock.
COMMON.—1, J. Mair. 2, J. Lamont, Kilwinning. 3, W. H. Mitchell. 4 and 1/2, W. McKinnay. c. J. McKinnay, Dalry.
OWLS (English).—1 and 1/2, J. Mair. 3, T. Douglas.
DOVES (Ringed or Turtled).—1, A. Wardrop. 2, J. Seonlar. 3, J. Dunlop.
ANY OTHER VARIETY.—1 and c. J. Sharp (White Owls and Ice Pigeons). 2, H. Yardley. 3, R. Thompson. 4, Miss E. A. Knott (Archangel). 5, G. B. Phillips, Ayr (Yellow Magpies).
SELLING CLASS.—1, W. Demar, Crosshouse (Pouters). 2, J. Galt. 3, J. G. Orr (Owls).

CANARIES, &c.

- YELLOW.—Cocks.—1, R. Houston, Kilmorie. 2, A. Kelley, Paisley. 3, A. Miller. 4, B. Bony, Overton. 5, W. Grievy, Kilmarnock. c. D. Holter, Irvine. Hens.—1, E. Cron. 2 and 1/2, R. Calderwood. 3, J. Calderwood. 4, R. Crawford, Kilmarnock. c. E. Bunting, Kilmarnock.
BUFF.—Cocks.—1 and Timepiece, J. Conn, Irvine. 2, R. Calderwood. 3, J. Calderwood. 4, J. Kerr. 5, J. Wilson. c. J. W. Will. Hens.—1 and 2, R. Calderwood. 3, R. Crawford. 1, J. Gray, Airdrie. 4, J. Calderwood, Kilmarnock.
PENGUIN (Yellow).—Cocks.—1, A. Miller. 2, A. Stewart. 3, J. Glasgow. 4, W. Mair. 5, C. Aird, Kilmarnock. c. A. Lyon. Hens.—1, A. Kelly. 2, D. Hobbs. 3, J. Gray. 4, A. Crawford. 5, J. Wilson, Beith. c. J. Seoular, Kilmarnock.
PENGUIN (Black).—Cocks.—1, T. Scott, Carlisle. 2, J. Calderwood. 3, J. Norris, Ayr. 4, A. Brown. 5, A. Robertson, Galston. c. J. Gray. Hens.—1 and Timepiece, A. Crawford. 2, J. Glasgow. 3, A. Borland, Galston. 4, J. W. Will. 5, c. A. Stewart.
GOULDEN MITRES.—Yellow.—1, J. Gray. 2, G. Bryden, Newton, Ayr. 3, G. Bryden. 4, 1 and 3, G. Gordon, St. Quivox, Ayr. 2, J. Gray.
GOULDEN MITRES.—1 and 2, T. Conn. 2, A. T. Kilmock.
HOME OR FOREIGN BIRDS.—1, W. Brown. 2, E. Mitchell. 3, J. Richmond.
JACOONS.—Mr. John Paul, Glasgow, judged the Spanish, Dutch, and Scotch Greys; Mr. Robert Caldwell, Kilmarnock, the Game and Bantam classes; and Mr. Alex. Paterson, Airdrie, the Polands, Variety, Duck, and Selling classes. Messrs. James Hmie, Glasgow, and George Ure, Dundee, judged all the Pigeons; and Messrs. George Masterton, Robert Paterson, John Kelly, and Alex. Brown, the Canaries, Mules, Goldfinches, &c.

EDINBURGH POULTRY SHOW.

This was held in connection with an exhibition of cattle and sheep, on the 7th and 8th inst. The following awards were made:—

- SPANISH.—Cochins.—1, A. Ridpath. 2, Mrs. Gillison. 3, J. Gray; Mrs. Gillison. c. W. Paterson. Mrs. Gillison. Fulls.—1, A. Uppich. 2, W. Paterson. 3, R. Somerville. D. Gellatly. Cocks.—1, A. Shepherd. 2, W. Paterson. 3, A. Ridpath. c. J. Gray. Hens.—1, A. Ridpath. 2, and 3, R. Somerville. 4, A. Shepherd.
DOLANS (Coloured).—Cochins.—1 Mrs. A. Bruce. 2, J. Anderson. 3, A. Bruce, jun. 4, R. Bond. 5, R. Bond. Mrs. Gillison. Fulls.—1, Mrs. Morrison. 2, A. B. Bruce, jun. 3, H. L. McDonald. 4, J. Anderson. D. Gellatly. Cocks.—1, W. Paterson. 2, D. Gellatly. 3, J. W. Will. Hens.—1, A. Bazaar. 2, J. Anderson. 3, H. L. McDonald. 4, H. R. Bond. Silver.—Cochins.—1, D. Young. 2, W. Gibb. 3, Lady G. G. Montaguery. 4, G. Buchanan. D. Annan. Fulls.—1, Lady G. G. Montaguery. 2, W. M. G. 3, J. Curror. 4, H. Pinner. c. Mrs. Balfour. Duke of Buccleuch. Cocks.—1, Duke of Buccleuch. 2, J. W. Will. 3, J. Gibson. Hens.—1, D. Annan. 2, Lady G. G. Montaguery. 3, Miss Swain.
COCHINS.—Cochins.—1 and Cup, E. Leech. 2, J. Cowman. 3, E. Leech. 4, H. Paterson. Fulls.—1, C. Siggwick. 2, Mrs. Oswald. 3, E. Fearn. c. F. Leech. Cocks.—1, J. Sichel. 2, C. Siggwick. 3, E. Fearn. 4, J. Gray. Hens.—1, J. Sichel. 2, C. Siggwick. 3, E. Leech. 4, E. Fearn. c. J. Cowman.
BRAHMA POOTRA.—Cocherels.—1, R. Brownlie. 2, Mr. Gillison. 3, J. Riddell; J. A. Dempster; Miss Morrison; — Gillison. Fulls.—1, T. Rainis. 2, J. Cowman. 3, W. J. Holdsworth; D. Annan; W. R. Park; J. R. Dale. c. A. Simpson. Cocks.—1, Mrs. Gillison. 2, J. Sichel. 3, W. Swann; Mrs. Gillison; J. W. Will. Hens.—1, E. Leech. 2, G. A. Stephens. 3, W. Smith; R. Brownlie. c. N. J. Killyer.
GAME (Black-breasted or other Ducks).—Cocherels.—1, C. Jamieson. 2, J. H. Wilson. 3, A. Shephard. 4, W. McThuma; J. Carlisle; Mrs. Harley; J. W. Will. c. D. Harde. Fulls.—1, Mrs. Harley. 2, Mrs. Jamieson. 3, A. S. Brewster; R. Stewart; Mrs. Harley. Cocks.—1, J. W. Will. 2, W. Meldrum. 3, Henderson and Allan; D. Harde; J. H. Wilson. Hens.—1, J. W. Will. 2, Henderson and Allan. 3, A. S. Brewster; Mrs. Harley. c. B. Stewart.
GAME (Any other Variety).—Cocherels.—1, Mrs. Harley. 2, J. Logan. 3, B. Charwick; J. Anderson. Fulls.—1, J. Elder. 2, and 3, Mrs. Harley. Cocks.—1, J. W. Will. 2, Mrs. Harley. 3, B. Black. Hens.—1, H. Goodall. 2, Mrs. Harley.
HAMBURGERS (Spangled).—Cocks.—1 and Cup, J. W. Will. 2, D. Forrester. 3, J. F. Loversidge; J. B. Cranston; Miss Brown; J. Watson; J. Logan. Hens.—1 and 2, J. W. Will. 3, W. Harpark; D. Cheyne; J. Logan.
HAMBURGERS (Pencilled).—Cocks.—1 and 2, J. W. Will. 3, M. Forrest; W. Balfour. 4, Cheyne; J. M. Harvey. Hens.—1, W. B. Park. 2, and 3, J. Walker. 4, H. Pickles, jun.; J. M. Harvey; J. W. Will; J. M. Forrest.
BANTAMS (Game).—Cocks.—1 and Cup, W. Grieve. 2, W. Scott. 3, D. White-law. 4, G. Gibb. W. Gibb; J. Gray; R. Brownlie. c. J. Waddell. Hens.—1, G. Dowie. 2, T. Rames. 3, A. Gibb; E. Fearn; J. Harvey; W. Scott; H. Goodall. 4, R. Brownlie. c. J. M. Campbell.
BANTAMS (Any other Variety).—Cocks.—1, Miss B. F. Frew. 2, J. W. Will.

he, J. Ferny; G. Allan; S. & R. Ashton; J. Archibald; e. T. Watson. *Hens*.—1, S. & E. Ashton; 2, W. Gibb; 3, Bliss B. P. Frew.
Spaniards.—1, W. Gibb; 2, D. Wadde.
ANY OTHER BREEDS.—1, C. Siderwick (Black Hamburg). 2, J. Sichel (Creve-Coeur). *he*, G. A. Stephens; W. B. Park; W. Bockpark; H. Pickles.
Ducks.—*Any other variety*.—1 and Cup, E. Leech. 2, J. Scott. *Bantams*.—1, E. Leech. 2, D. Harde. *Any other variety*.—1, C. N. Baker. 2, T. Clarkson.
SEVERAL CLASSES.—*Cocks*.—1, A. Williamson (Cochin). 2, W. Paterson (Spanish). *Ties*.—1, A. Bowie. 2, W. Shirton.
TURKEYS.—1, J. Wilson. 2, Ducks of Baclench. *Bouls*.—1, E. Leech. 2, Duke of Buccleuch.
Geese.—1, E. Leech. 2, D. Harde.
JUDGES.—Mr. R. Teebay, Fulwood, Preston; and Mr. D. Brown, Verth.

BERWICK AND BORDER ORNITHOLOGICAL ASSOCIATION'S SHOW.

The Berwick and Border Ornithological Association, which was formed this year, held its first annual exhibition of British and Foreign Cage and Song Birds in the Corn Exchange on the 7th and 8th inst. Altogether there were 208 of the feathered tribe. The prize list is as follows:—

BULLDOGS.—*Clear Yellow*.—1, G. Norris, Berwick. 2, J. Baxter, Newcastle. 3, J. G. Chris. 4, Berwick. 5, J. Baxter; 6, Norris (this would have been a double if the second prize had for an accident destroying the plumage). *e*, R. Hall, Bedford. *Clear Buff*.—1, J. Thompson, Tweedmouth. 2, G. Norris. 3, C. Lugton, Hillman. *Any other variety*.—1, G. Norris. 2, J. Thompson. 3, S. Bunting, Derby. *he*, G. J. Barnsby; R. Hall; J. B. Gilchrist. *e*, J. Oxyton. 4, W. Scott. *Blue*.—1, R. Hall. 2, G. Norris. 3, R. Gresham. 4, J. A. Scott. *Red*.—1, R. Burnett. *Clear Buff*.—1, C. Lugton. 2, D. Allen. 3, J. Spidding, Stockbridge, N.B. *he*, R. Forsyth; W. Young. *e*, S. Robinson, Berwick. *The Cock*.—1 and 2, Allen. 3, W. Young. *he*, T. Dippie. *Norwich*.—*Clear Junco*.—1, G. J. Barnsby, Derby. 2 and 3, Moore and Wynne, Northampton. *he*, S. Bunting; Wallace & Beloe, Berwick; W. Young. *Clear Buff*.—1 and 2, G. J. Barnsby. 3, S. Bunting. *he*, R. Hayman, Middleburgh. *S. Bunting*; Moore & Wynne (2); W. Young. *he*, W. Young. *e*, R. Hall, Moor. *Norwich*.—*Evenly-marked Yellow*.—1, S. Bunting. 2, Wallace & Beloe. 3, Moore & Wynne. *he*, R. Hayman; E. Mills. *he*, Wallace & Beloe (3); Moore & Wynne. *e*, J. Baxter. *Evenly-marked Buff*.—1 and 2, Moore & Wynne. 3, W. Young. *he*, E. Mills, Sunderland; Wallace & Beloe. *he*, Wallace and Beloe (4). *Norwich*.—*Unevenly-marked Junco*.—1, G. J. Barnsby. 2, S. Bunting. 3, W. Young. *he*, R. Hayman. 4, R. Hall. *Unevenly-marked Buff*.—1 and 2, J. Barnsby. 3, R. Hayman. 3, S. Bunting. *he*, G. Green, Lothian; Wallace and Beloe (2). *e*, Wallace & Beloe. *Norwich* (Clear Junco or Buff, with Crest).—1, Moore & Wynne. 2, S. T. Jones, Northampton. 3, Wallace & Beloe. *he*, Wallace & Beloe; W. Clarkson, York; G. Shiel, Sunderland. *Norwich* (Clear Junco or Buff, with Dark Grey, or Clear Crest).—1, Cup, and Mr. E. L. Wallace & Beloe. 2, G. J. Barnsby. 3, Moore & Wynne. 4, Moore & Wynne; W. Young (2); G. Shiel. *he*, Wallace & Beloe (3). *e*, W. Johnson, Berwick. *CINCINNATI*.—1, Moore & Wynne. 2, S. T. Jones. 3, Wallace & Beloe. *he*, Wallace & Beloe; S. T. Jones. 4, S. Bunting; G. Shiel. *Buff*. 1 and 3, Moore and Wynne. 2, Wallace & Beloe. *he*, Master G. Wallace; Wallace & Beloe. *CINCINNATI* (variegated Yellow or Buff).—1 and 2, S. T. Jones. 2 and 4, Wallace and Beloe. 3, Moore & Wynne. *e*, D. Allan; Stevens & Burton. *ANY OTHER VARIETY*.—1 and 2, Stevens & Burton. 3, S. T. Jones. *he*, R. Hayman; Fairclough & Howe, Wallace & Beloe; W. Young. *he*, G. J. Barnsby; W. L. Miller (2); E. Mills. *GREENFINCH MOLE*.—*Marked or Variegated Yellow*.—1, J. Baxter. 2, Stevens and Burton. 3, G. Shiel. *e*, G. Thompson. *Marked or Variegated Buff*.—1 and 2, G. Shiel. 3, Fairclough & Howe. *he*, J. Baxter, Newcastle (2); W. & C. Barnston, Middleburgh; G. Shiel. *he*, S. Bunting. *Duck*.—1 and 2, Moore and Wynne. 3, Stevens & Burton. *he*, G. H. Ellis, Ashford, Bedfordshire. *e*, J. B. Bower, Berwick. *he*, W. L. Miller, Berwick; R. Faxon, Bedford. *GOLDEN PHEASANT*.—1, J. Baxter. 2, Fairclough & Howe, Middleburgh. *he*, S. Bunting; Stevens & Burton. *he*, W. & C. Barnston. *e*, J. B. Gilchrist. *GERMAN BIRD* (Any other variety).—1, G. Shiel. 2, W. & C. Barnston. *he*, J. Baxter, Newcastle; T. Robertson, Berwick; Fairclough & Howe; W. Grey, Berwick. *FOREIGN BIRDS* (Any variety).—2, Capt. T. Williams, Coldstream. *he*, W. and C. Barnston.

DISTRICT PRIZES.

Yellow or Buff (Any breed).—1, J. G. Nisbett, Berwick. 2, W. Allan, Berwick. 3, W. Gibson, Berwick. *he*, T. A. Glaston, Berwick; J. Giegze. 2, W. Leck. 1, Grey, Berwick; J. Purves, Berwick. *e*, W. Head-smith, Berwick. *ANY OTHER BREED* (Any breed).—1, J. G. Nisbett. 2, J. Lindsay, Berwick. 3, J. Gilchrist. *he*, W. Gilchrist. *e*, J. Giegze; T. Robertson (2); J. Lindsay; 4, Fairclough, Tweedmouth.

The Judge was Mr. Robert Pearson, Durham.

DORKING POULTRY SHOW.

This was held on the 8th inst. The following are the awards:—

DORKINGS.—*Coloured*.—1, M. Putney, Dorking. 2, L. Patton, Hillmore, Tinton. 3, Rev. J. D. Hoysted, Bradenstoke. *he*, F. May, Reigate. *e*, Ivery and Son, Dorking. *Chickens*.—1, Ivery & Son. 2, G. Cubitt, Dorking. 3, J. Smith, Southwark Park, Peterborough. *he*, G. H. Ellis, Ashford, Bedfordshire. *e*, L. Patton; W. B. Boxall. *Cockerels*.—1, J. Smith. 2, M. Putney. 3, G. Hine, Westcott. *he*, Ivery & Son. 4, Rev. M. Idee. *Pullets*.—1, G. W. Greenhill, Ashford. 2, H. Humphry, Ashtington. 3, W. E. Boxall. *he*, E. May. *e*, G. Ellis.

OPEN TO MEMBERS.

DORKINGS.—*Coloured*.—1, W. Fell, Westcott. 2, Ivery & Son. 3, M. Putney. 4, E. T. Bennett, Betchworth. *he*, D. B. Green, Brockham Court. *Chickens*.—1, Ivery & Son. 2, G. Hine. 3, W. Fell. 4, M. Putney. *he*, Z. Greenfield. 5, F. May. *Cock*.—1, Ivery & Son. 2, W. Fell. *he*, G. Hine. *Cockerel*.—1, Ivery & Son. 2, W. Fell. *he*, Rev. H. J. Cummins, Enfield. *he*, M. Putney. *Hens*.—1, M. Putney. *e*, W. L. Green. *he*, W. Fell. *e*, E. T. Bennett. *Pullets*.—1, W. Fell. 2 and 3, G. Hine. *he*, Ivery & Son. *DORKINGS*.—*Blue-speckled*.—1, Mrs. Mayo, Dorking. 2, W. Griffin, Westcott. 3, W. Phelps, Dorking. *e*, G. Hine. *Chickens*.—1, W. Phillip. 2, G. Hine. 3, G. Hine. *e*, W. Leitcher, Great Bookham. *Cock*.—1, E. Neal, Dorking. *he*, G. Hine. *e*, J. L. Playfoot. *Hens or Pullets*.—1, G. Cubitt. *he*, W. Griffin. *e*, G. Hine. *BORINGHAM*.—*White*.—1, G. Cubitt. 2, J. Rargam, Dorking. 3, W. Attlee, Dorking. *he*, Lady M. Jones, Dorking. *e*, G. Hine. *Chickens*.—1, G. Hine. 2, W. Attlee. 3, W. J. Evelyn, Wotton, Dorking. *he*, G. Cubitt. *e*, W. Attlee; W. E. Watson, Woodford, Dorking. *Cock*.—1 and 2, J. Rargam. *he*, G. Hine. *he*, W. Attlee. 1, J. Attlee. 2, W. Fell. *he*, W. E. Watson. *e*, G. Cubitt.

Ducks.—*Aylesbury*.—1, W. F. Watson. 2, J. B. Nichols, Dorking. 3, J. M. Putney. *he*, D. B. Green. *Any other variety*.—1, Ivery & Son. 2, J. B. Corbet. 3, G. Cubitt.
Geese.—1, W. Messenger, Womersley. 2, W. F. Watson. *Chickens*.—1 and *he*, W. Attlee. 2, W. Messenger.
TURKEYS.—1, W. Messenger. 2, W. F. Watson. *he*, D. Christie. *e*, W. J. Evelyn.
JUDGES.—Mr. John Wood and Mr. Jenkins.

YORK POULTRY, PIGEON, AND RABBIT SHOW.

This Show opened to the public on the 6th inst., and was by far the best Exhibition, regarding both numbers and quality, held in the ancient city. The receipts were much larger than in any former year.

The following shows the number of entries at each of seven years' exhibitions:—

Year.	Poultry.	Rabbits.	Pigeons.	Year.	Poultry.	Rabbits.	Pigeons.
1861	255	5	276	1870	344	69	183
1862	312	58	314	1869	334	69	187
1863	278	65	259	1870	344	124	183
1867	276	65	124				

Dockings held the post of honour, and were, indeed, worthy, being seventeen pens, all good, with a splendid pen of Mr. White's first. There were one or two cockerels with the spur outside, and some hens with very bad claws. Exhibitors should keep such at home. Only one pen of a full *Spanish* came before the Judges, but they would, no doubt, have held their own against a very much larger field. Of young *Spanish* there were six pens, of which four obtained notice; it was a beautiful class. *Cochins* mustered twenty-two pens. There were several very neatly-winged cocks; and in *Buffs*, with the exception of the prize pens, they were far from being up to the standard. The *Partridge-coloured* were very superior to them in all points. Only one pen of very inferior *Whites* were shown. *Brahmas* occupied sixteen pens, old and young competing together. The first-prize pen was very fine, the cock, if anything, coarse in the head and not good in comb, but his partner was everything that could be wished for, in size, depth of colour, &c. There were several white-tailed brown-feathered cocks shown with vulture hocks nicely drawn. *Guns* filled forty pens in four classes, and were quite a treat to the lovers of those birds. Of *Hamburghs*, there were forty-five pens in four classes. The Gold-pencilled were only a moderate lot, with the exception of the prize pens. Being in the darkest corner of the Show, also in three tiers, one after the other, they were very difficult to see; neither Judges nor exhibitors had a fair chance. Hollow combs and very mossy hens abounded. The Silver-pencilled, with the exception of the first-prize pen, which had a beautiful-tailed cock and fine-marked hen, were poor, the difficulty being to award three prizes amongst them. The Spangled birds were decidedly better, and the prize pens left little to find fault with. *Polish* occupied ten pens, the Gold-spangled being the best. The *Game Bantams* mustered forty-four pens, but were, like the Gold-pencilled *Hamburghs* mentioned above, in a dark corner and four tiers, one over the other, and it being a dark day, great difficulty was experienced to obtain a sight of them. Where so many were good it was difficult to choose the best, but the first-prize cock was a beauty, and carried himself in true *Game* style; too many in this class betraying their Bantam origin by their drooping wings, &c. Of *Laced Bantams* there were only two entries, which were both good. In *Bantams* of any colour eight entries were made; the first and second going to *Blacks*. The hen in the first prize pen was a little gem, but the cock in the second-prize pen more stylish. In the "Any other variety" class were seventeen entries. *Black Hamburghs* took the first, and *Sultans* the second prize, with *Houdans*, *Creve-Coeurs*, and *Malays* in the order of merit. This was a fine class, one or two good pens arriving too late. Of *Turkeys*, the old birds weighed 44 lbs., and the young ones 36 lbs. In *he*, the Rev. G. Huxter had it all his own way, his first-prize pen of *Whites* weighing 54 lbs.; while the second-prize pen of Mr. Leech's only gave 194 lbs. when they came to the scales. Mr. Huxter may be proud of having won on the same day a double victory at the Crystal Palace and York with such splendid birds. The *Aylesbury Ducks* occupied fifteen pens. The first-prize birds weighed 16 lbs., and the second 154 lbs.; both being very good in bills and plumage. Of *Rouens* there were nineteen pens; 16 lbs. the weight of the first, and 15 lbs. of the second-prize birds. They were very fine in shape, colour, and bill. In the "Any variety" class were six pens. *Black East Indians* were first, and *Brown Cal Ducks* second.

As at the Crystal Palace, so at York, the "Selling class" was, perhaps, the most remarkable in the Show, and abounded with fine specimens of different varieties, which we were glad to see marked "sold" in large numbers. Fifty-five entries, *Dorkings* taking first, *Brahmas* second, *Cochins* third prizes; but it is a pity not to have a separate class for *Ducks*, *Geese*, and *Turkeys*, for with only three prizes in a class the Judges could not fairly please themselves; they gave a very high commendation to *Black East Indian Ducks*, with a high commendation to *Aylesbury*, and sixteen commendations in this the best class in the Show.

RABBITS.

NEVER, perhaps, before in this country was collected together for exhibition so numerous or valuable a stock of Rabbits, six distinct varieties being well represented, and amongst some of them the best specimens in the country. It really was difficult to determine which most to admire—the sedate yet graceful *Lop-eared*; the showy and

founded in the cells, and afterwards quickened by the influence of the drone?

This method of fertilisation was long believed by apiarians to have been "established beyond all contradiction," by the observations of M. Deuran, of Cambridge. It was not till Huber exposed the optical illusion which misled, that the bee world learned they had been accepting as true a conclusion which was altogether untenable. The processes that are now so much in vogue, though somewhat modified, were found in the hands of M. de Réaumur and Huber to be wholly without result. "We have," says the latter, "frequently confined virgin queens with drones of all ages. We have done so at every season, and witnessed all their advances and solicitations towards the males. Nothing, indeed, was left undone by him that was deemed likely to bring about a marriage in confinement, but without a fertile result.

Now, if the procedure adopted by the honey bees is at all similar to that followed by the wild species (and I have no doubt it is), the union of the sexes must necessarily take place on the wing in the open air. I had an excellent view of the conjunction of the *Bombus terrestris*, male and female, on the 18th of September, 1857.

In these cases where fertilisation has been supposed to have been effected when the queen was confined, I would like to ask whether all due precautions have been used to prevent its having taken place in any other situation. When we obtain a seemingly pure offspring after a pure Ligurian queen has been shut up with pure Ligurian drones, we are not to take this as a proof of the royal marriage having been contracted when in durance. It is very difficult to say when a pure breed has been secured.

I had a queen this summer, the daughter of one hybridised last year, which produced the finest-looking Italians. Not a cross was to be seen amongst them, and some half dozen young queens reared naturally after swarming were all beautifully marked. Yet all these queens which were put at the head of colonies, became mothers of a dark race with scarcely a trace of Italian features either in shape, size, or colour.—R. S.

OUR LETTER BOX.

BRECON POULTRY SHOW.—Mr. Brien has explained to us that the non-payment of prizes has not been his fault. After the 22nd inst. he will be enabled to pay them.

GAME BANTAMS MUTILATED AT THE DUBLIN SHOW (E. C. H.).—Our correspondent complains that the cock's sickle feathers were cut off and the tail otherwise injured. The mutilation was done previous to the judging, and he warns other exhibitors there to "look sharp."

EGG-EATING HENS (Constant Subscriber).—You can only watch the hens and drive them from their nests as soon as they have laid. It is sometimes useful to lay hard eggs about, so hard as to defy all efforts to peck pieces off.

HOBDAVS' TOPS (J. S.).—One too turning up and the other downwards is not a disqualification.

HAMBURGERS (S. D. C.).—We do not care for the colour of a Hamburger cock's eye. We cannot advise you about breeding, as we do not see the birds. If the son has produced part of your requirements, but you wish for more, use him again, not with his mother but his sister—with his mother he will merely produce again that which he produced before. A fellow in the comb is a disadvantage. A tail should not be too much bronzed, but it is a venial fault. We know nobody's indoligencies in poultry judging. You had better write to the judge in question. A hen with a pencilled tail is more likely to breed pencilled-tailed pullets than one with a blacking-brush tail.

POULTRY FEEDING (Hunt Henwife).—Your feeding is troublesome, expensive, and poor. We do not like either Indian meal, sharps, or buckwheat. They all go to make internal fat, and to prevent laying. Give them ground oats every morning, kitchen scraps, and Indian corn mid-day, and ground oats in the evening. It is bad crossing sitters and non-sitters, or we would advise Dorkings.

HASTENING LAYING (R. H.).—Your Dorkings are hardly arrived at an age to lay. Have patience. Grooves, meat, and hempseed will force them, but you will be a loser in the end. There is a great outcry for eggs; we hope those who have them will stand out for a great price, and that the present will make us wiser in futurity, and less dependant on a foreign supply.

COCKEREL FOR EXHIBITION (T. F. A.).—Allow him one pullet. Feed as we advise. If the shows are near at hand put him by himself; not, however, if other hens are about. If he can see them, it is better to allow him one pullet, or he may lose weight. Feed as we advise.

HENS APPARENTLY EGG-BOUND (M. H.).—The symptoms you describe are those of an egg-bound hen, but as there has been no egg, it is probably only a derangement which Billy's spilla, following on castor-oil, should cure. The cure will not be perfect till the evacuations are partly white. Give up the oats which they will not eat, and the potatoes which are worse than not doing, making internal fat, and causing diseased livers. Substitute ground oats. When twelve hens die at about the same time, it is fair to suppose they pick up something poisonous.

TERRITS (T. A. B.).—Put your Black cock with a Black hen, not a Red one. We do not crossing Blacks with Red's years ago, and the produce was always Strawberry, both colours being entirely spoiled. Point crows are best for Turkeys.

CARRIERS (E. Laurie).—It is usual with Carrier fanciers to match Blacks and Duns together, the idea being that a more brilliant black is the result. The fineness of plumage you allude to results most probably from the owner of the birds being able to fly them. Another thing producing fine colour and appearance is not exhibiting birds; they are injured by travelling. At the Peristeric Meeting, the birds exhibited by gentlemen members who do not show for prizes are far superior in appearance as to colour and gloss, to the poor birds that have been sent to shows all over the country. As to food, beans and old tares are the best for all Pigeons.

CRYSTAL PALACE POULTRY SHOW.—Through an error in the catalogue of the Crystal Palace Show we reported that Mr. E. Tindman took the first prize for an old Partridge Cochon cock and hen, whereas the first prize was awarded to pen 157, belonging to Mr. Linwood, Creeting, Suffolk. Mr. H. Slumach says his pen, 823, of Black Red Game Bantam pullets was awarded the second prize. Mr. Lorimer informs us that he took the second prize in class 111 (Pigeons, any other variety) with a pair of Pouterrels. We are informed that in the class for Black Ducks a fourth prize was awarded to pen No. 1178, belonging to Mr. G. S. Sainsbury. In the class for Aylesbury Ducks the first prize was awarded to Mrs. Semons, not Mr. Hollis.

WHITE COCKATOO (E. M. D.).—The bird picking off his feathers indicates that there is irritation of the skin. Give him a shower-bath daily by pouring over him tepid water through the nose of a watering-pot. Give him no bones nor meat, only sopped bread and fruits.

METEOROLOGICAL OBSERVATIONS

In the Suburbs of London for the week ending December 13th.

DATE.	BAROMETR.		THERMOMETER.				Wind.	Rain.
	Max.	Min.	Air.		Earth.			
			Max.	Min.	1 ft.	2 ft.		
Wed... 7	29.629	29.608	41	16	40	40	N.	.03
Thurs... 8	29.636	29.618	32	29	49	40	N.	.10
Fri... 9	29.816	29.659	34	30	59	39	N.	.00
Sat... 10	29.900	29.850	35	32	41	39	N.	.32
Sun... 11	29.809	29.578	59	27	41	39	S E.	.39
Mon... 12	29.281	29.185	52	42	42	39	W.	.26
Tues... 13	29.424	29.306	56	45	43	41	S.	.55
Mean..	29.641	29.542	49.00	31.57	40.83	34.43	..	1.24

- 7.—Overcast; densely overcast; cold and overcast.
- 8.—Sharp frost; overcast; snow at night.
- 9.—Snow; continued fall of snow; densely overcast.
- 10.—Densely overcast; dense fog; densely overcast.
- 11.—Overcast; very fine; cloudy, frosty air.
- 12.—Rain; cloudy but fine; slight rain.
- 13.—Drizzling rain; rain; drizzling rain.

COVENT GARDEN MARKET.—DECEMBER 14.

We have no improvement here worth notice, except in the best Grapes, which have advanced in price during the week, and continue very good. The Potato trade is steady, and the supply ample.

FRUIT.

	s. d.	s. d.		s. d.	s. d.
Apples... doz.	1 0	2 0	Mulberries... lb.	0 0	0 0
Apricots... doz.	0 0	0 0	Nectarines... doz.	0 0	0 0
Cherries... lb.	0 0	0 0	Oranges... doz.	10 0	0 0
Chestnuts... bushel	10 0	18 6	Peaches... doz.	0 0	0 0
Carrots... doz.	0 0	0 0	Pears, kitchen... doz.	1 0	2 0
Black... do.	0 0	0 0	dessert... doz.	1 0	2 0
Figs... doz.	0 0	0 0	Pin Apples... lb.	3 0	5 0
Filberts... lb.	0 0	2 0	Plums... doz.	1 6	3 0
Gobs... lb.	2 0	2 6	Quinces... doz.	0 0	0 0
Gooseberries... quart	0 0	0 0	Raspberries... lb.	0 0	0 0
Grapes, Hothouse... lb.	4 0	8 0	Strawberries... lb.	0 0	0 0
Lemons... per 100	6 0	10 0	Walnuts... bushel	10 0	16 6
Melons... each	1 0	4 0	do... per 100	1 0	2 0

VEGETABLES.

	s. d.	s. d.		s. d.	s. d.
Artichokes... doz.	0 0	0 0	Leeks... bunch	0 4	0 0
Asparagus... per 100	0 0	0 0	Lettuce... doz.	0 3	1 6
Beans, kidney... per 100	2 0	3 0	Mushrooms... pottle	1 0	2 0
Broad... bushel	0 0	0 0	Mustard & Cress, pinneret	0 2	0 0
Beet Red... doz.	2 0	3 0	Onions... bushel	3 0	5 0
Broccoli... bundle	0 9	1 6	pickling... quart	4 0	6 0
Brussels Sprouts... sieve	2 0	3 0	Parsley... sieve	3 0	0 0
Cabbage... doz.	1 0	2 0	Parsnips... doz.	0 9	1 0
Cauliculus... per 100	0 0	0 0	Peas... quart	0 0	0 0
Carrots... bunch	8 0	4 0	Potatoes... bushel	2 0	4 0
Chick-peas... doz.	2 0	6 0	Radishes... doz.	3 0	4 0
Celery... bundle	1 6	2 0	Radishes... doz. bunches	0 6	1 0
Col-worts... doz. bunches	8 0	0 0	Rhubarb... bundle	0 0	0 0
Cucumbers... each	0 2	1 0	Sage... doz.	1 6	2 0
pickling... doz.	0 0	0 0	Sea-kale... basket	2 0	2 0
Endive... doz.	2 0	2 0	Sballots... lb.	0 6	0 0
Fennel... bunch	0 8	0 0	Spinach... bushel	2 0	2 0
Garlic... lb.	8 0	0 0	Tomatoes... doz.	3 0	6 0
Herbs... bunch	8 0	0 0	Turpins... bunch	0 6	0 0
Horseradish... bundle	3 0	5 0	Vegetable Marrows... doz.	0 0	0 0

POULTRY MARKET.—DECEMBER 14.

We have still a sorry trade, and have lost the inspiring effect of frosty weather. Trade is very bad now, but we look for a good Christmas market, from the absence of foreign supplies.

	s. d.	s. d.		s. d.	s. d.
Large Fowls... 3	0	2 6	Pigeons... 0	9	0 10
Smaller ditto... 2	0	2 6	Rabbits... 1	3	1 5
Chickens... 1	6	1 9	Wild ditto... 0	9	0 10
Ducks... 1	9	2 3	Hares... 2	0	2 6
Geese... 6	0	7 6	Pardidges... 1	9	2 0
Partridges... 1	6	2 0	Grouse... 0	0	0 0

WEEKLY CALENDAR.

Day of Month	Day of Week	DECEMBER 22—28, 1870.	Average Temperature near London.			Rain in last 49 years.		Sun Rises.		Sun Sets.		Moon Rises.		Moon Sets.		Moon's Age.	Clock after Sun.		Day of Year.
			Day.	Night.	Mean.	Days.	m.	h.	m.	h.	m.	h.	m.	h.	Days.		m.	s.	
22	Th	Winter commences.	45.0	32.5	38.7	21	6	48	51	43	55	47	58	43	●	1	11	356	
23	F		44.1	31.7	37.9	21	6	8	51	3	5	9	53	4	1	0	40	357	
24	S		44.0	31.3	37.6	17	7	8	52	3	59	9	10	6	2	0	10	358	
25	Sun	CHRISTMAS DAY.	43.4	29.4	36.4	9	7	8	53	3	49	10	25	7	3	before		359	
26	M	ST. STEPHEN.	43.2	31.4	37.3	16	8	8	53	3	12	11	42	8	4	0	5	361	
27	Tu	ST. JOHN EVANGELIST.	43.0	29.7	36.4	15	8	8	54	3	34	11	55	9	5	1	19	361	
28	W	INNOCENTS' DAY.	42.6	29.5	36.0	13	9	8	55	3	55	11	5	11	6	1	49	362	

From observations taken near London during the last forty-three years, the average day temperature of the week is 43.6°, and its night temperature 30.8°. The greatest heat was 58°, on the 25th, 1827; and 28th, 1855; and the lowest cold 11° below zero, on the 28th, 1861. The greatest fall of rain was 1.13 inch.

TEA ROSES FOR OUT-DOOR CULTURE.



At page 438 are given, in reply to the inquiry by a correspondent, the names of some select Tea-scented Roses for out-door culture. To the excellence and beauty of the kinds there named no Rose amateur will, I think, take exception, but the suitability of a few of them for out-door culture is open to some discussion, and not of these only, but the subject of Tea Roses out of doors is one that might be resumed with interest.

The Tea-scented Roses (*Rosa indica odorata*) are the desire, and but too often the envy, of all lovers of Roses: they have a charm and fragrance peculiar to themselves which attract to them a preference beyond all other kinds. Their successful culture in the open ground, with a very few exceptions, is beset with difficulties. They will not generally grow where the hardier species often flourish; they require more care, more assiduous attention than any other race of Roses, and the luxury of obtaining them in quantity and variety is seldom acquired without the aid of glass structures, with pot-culture, or planting out in a house specially devoted to them.

Slowly but surely the number of varieties of the Tea-scented Roses of approved quality and sufficiently hardy for out-door planting is increasing, and among these the Noisettes may be included, for the difference between the two sections is one of degree rather than of kind, so that no Rose garden, nor any flower garden whatever, ought now to be without them altogether. The selected kinds recommended for this purpose in the list above alluded to are Gloire de Dijon, Abricote, Vicomtesse de Cazes, Devoniensis, Adam, Boule d'Or, Madame Levet, Jaune d'Or, Belle Lyonnaise, Adrienne Christophle, Montplaisir, and Madame Damazin. Of these, Abricote, Adam, and Vicomtesse de Cazes have with me proved too tender, and too dwarf and feeble in growth to withstand even an ordinary winter; under glass, however, they appear more vigorous, and potted in soil adapted for this class of Roses they produce very beautiful flowers. Boule d'Or failed to expand its bloom, in addition to its tender habit of growth. The insertion of Madame Levet in the list I am inclined to believe is a clerical error, having never heard of a Tea Rose of that name. Jaune d'Or, Belle Lyonnaise, Adrienne Christophle, Montplaisir, and Madame Damazin I have not tried.

Gloire de Dijon is well known to thrive in almost any ordinary situation. Scarcely less hardy is Celine Forestier, a deservedly universal favourite. With slight modification may be added Maréchal Niel, by far the best of all yellow Roses, and unsurpassed in depth and in substance of petal, combined with rich colouring and symmetrical form; Sombreuil is a lovely white Tea Rose of fine shape, abundant bloom, and vigorous growth. These four may all be successfully grown, even in light soils, as is the case here, budded on the Dog Rose at from 6 to 12 inches above the surface. They form handsome pillar Roses if treated in the manner pointed out by Mr. W. Paul in a recent article

in this Journal. If it can be avoided, Maréchal Niel and Sombreuil should not be exposed to the north and north-east winds. As they grow well on the Briar they will, of course, form standards; but it is especially objectionable to see attempts to prune and drill Roses into a shape they will not naturally assume.

The following Tea Roses have been fully exposed here during four successive winters—that is to say, they are planted out in front of a south wall, and no care has been taken to give them any further protection than the wall affords. They may, therefore, be presumed to be sufficiently hardy for a like situation. They are Devoniensis, Madame Bravy, Alba rosea, Rubens, Madame Willermoz, Madame Margottin, Madame Falcot, Souvenir d'un Ami, Homere, Narcisse, Goubault, President—all well-known kinds, acknowledged to be among the best of this class: they are on the Manetti stock. Madame Falcot and Goubault are most beautiful before complete expansion. Madame Margottin is a beautiful deep yellow Rose, with a peach or rose centre, and fine foliage. Homere has its petals jagged or irregularly notched, which is a drawback. Narcisse is a pretty pale yellow, and one of the freest blooming of all Roses.

The chief conditions required for the culture of Tea-scented Roses out of doors are light or well-drained soil—such as will not retain an excess of moisture during cold weather—free exposure to sun and air, shelter from north and north-east winds, occasional mulching, and a supply of well-rotted stable manure among the plants, which are best arranged in groups or in beds, and not dispersed; and further to promote vigorous growth, give a moderate watering in dry and warm weather with manure water. With these simple and inexpensive precautions it will be found quite possible to admit representatives of this noble class of Roses to a place in open-air gardening.

There is a freshness and delicacy of colouring in the flowers of the Tea Roses grown in the open air that does not seem to be so fully realised under glass: it must, however, be admitted that to have them in variety sufficient to include all or most of the best kinds, many of which are too tender for out-door culture, a glass structure is indispensable.

One more hint may be useful to those who from taste or circumstances of soil still desire to grow Roses in quantity in the form of standards at a height of more than 3 feet from the ground; at this height it is necessary, in order to secure the plants from injury by winds, to tie each firmly to a stake, and when the number of plants is considerable, the staking and tying are also a matter of considerable trouble. My respected neighbour, Mr. Tucker, of Garston House, wishing to have rows of standard Roses by the sides of the principal walks in his garden, has adopted a simple expedient which avoids the trouble of staking each plant, and which in the case of wooden stakes has frequently to be repeated. At each end of the row is a stout pole of willow, to which are affixed the ends of a length of galvanised iron wire at the required height. The standard Roses are held firmly to the wire by a soft liga-

ture of tarred string, or other substance suitable to the purpose. The poles are of willow because they take root after insertion in the soil, and therefore do not rot, but last for almost any length of time; the wire is galvanised because it is less liable to rust, and is not unsightly. When the willow poles are inserted, holes are dug in the places where wanted, and the poles, with the attached wire, are held inwards at an angle of 60° or thereabouts; they are then driven in to the required depth, and afterwards pulled outwards till they are perpendicular, when they are tightly rammed in: by this means the wires are rendered stiff by the tension. This plan appears to answer admirably; it would answer still better if two wires instead of one were attached to the willow poles. Such a contrivance is, of course, applicable to Raspberry canes, Holly-hocks, &c.

And now winter is again upon us with all its apprehensions, and which must not be forgotten, all its blessings. Among the many pleasant souvenirs which the recurrence of Christmas and the New Year bring, few, I will venture to say, will be more acceptable to the readers of "our Journal" than the genial kindly article of "WILTSHIRE RECTOR."—A. H. KENT.

CULTIVATION OF PEARS IN POTS.

MANY consider the Pear the best kind of fruit, and all know that, at any rate from September to March, this fruit is exceedingly valuable for dessert. The excellent specimens of Josephine de Malines exhibited by G. F. Wilson, Esq., of Weybridge Heath, are well worthy of notice as showing what can be accomplished by skill.

Mr. Wilson's trees are allowed to remain in the orchard house until the fruit are set, when they are removed to a favourable position out of doors. Such fruit of Josephine de Malines as exhibited could not be produced from trees planted out as pyramids or bushes. Two trees of Josephine de Malines were planted out at this place about five years ago; one of them is grafted on the Pear, and the other on the Quince. They were both good trees when planted; the ground was twice trenched, and prepared with suitable loam; they grow well, and sometimes have plenty of blossom, but little good fruit have they produced. In the season of 1866 about two dozen medium-sized fruit were produced, which ripened in February, and were of excellent flavour. With this single exception the produce has been worthless.

The varieties which have done best as pyramids and bush trees are Williams's Bon Chrétien, Louise Bonne of Jersey, Marie Louise, Beurré d'Amanlis, Napoléon, Triomphe de Jodoigne, and Jargonelle. A very large tree of Beurré Bose annually bears good crops of fine fruit. Beurré d'Artemberg also does well as a pyramid on the Pear.

On walls the finer sorts of Pears can be grown to great perfection, but not finer than they can be produced from trees in pots. I had some pots of Louise Bonne and Beurré d'Amanlis which were this season turned out of doors, when the fruit was set, to ripen; and that ripened out of doors was not only higher-coloured and of a better flavour, but quite as large as that produced under glass.

There is one Pear which can be highly recommended which has been grown here two seasons—Madame Treyve. It ripens in September, and although good Pears are plentiful at that season, it can be added to the most select collection. I selected six fruit of several of the varieties grown in pots, and weighed them. The following are the weights:—

	lbs.	ozs.
6 Williams's Bon Chrétien	3	12
6 Rivers's Beurre d'Artemberg	1	9
6 Jersey Gratioli	1	8
6 Beurré d'Amanlis	3	8½
6 Duchesse d'Orléans	2	2½
6 Madame Treyve	2	5½
6 Beurré Diel	3	14½
6 Conseiller de la Cour	3	10½
6 Louise Bonne of Jersey. (The tree, grown in a 13-inch pot, had three dozen good fruit.)	2	12

Pear trees in pots delight in rich surface dressings and plentiful supplies of water until the fruit is approaching ripeness, when it ought to be supplied to them more sparingly. About twice a-week they should have manure water. During winter, and until March, the pots may be plunged out of doors.

To amateurs and others who have not a large extent of wall-surface this method of cultivating the finer sorts of Pears might be a source of much profit as well as pleasure. The same

trees can be grown for many years in comparatively small pots; some of the trees here are about nine years old, and are in 15-inch pots.—J. DOUGLAS.

WINTER-BLOOMING ORCHIDS.—No. 11.

PHAJUS.

A GENUS of terrestrial Orchids of noble growth, containing some twenty or more species, but I purpose introducing only two of these to the attention of my readers, and they are invaluable for winter decoration. These species are extremely easy to cultivate, if it be only remembered that they are terrestrial, and not epiphytal; and the soil I have found to suit them well is a compost consisting of good turfy loam, fibrous peat, and well-decomposed manure in about equal parts, and just sufficient river or silver sand should be added to the whole to make it feel gritty. In this mixture pot the plants just previous to their growth commencing, and be sure the pots are well drained, and that the plants are not elevated above the rim, but potted like any other stove plant. Treat them liberally with water, and give them a good place in the East Indian house during their period of growth; after this is completed gradually reduce the supply of water, and remove them to a cool place, where they may remain until the end of October or beginning of November, when they should again be brought into heat, and moderately supplied with water. This treatment will soon cause the flower-spikes to show up, and grow more or less quickly, according to the weather prevailing at this time of year. Under this mode of management I have usually had some of my plants blooming at Christmas, and found them exceedingly useful just at the time when flowers are scarce and much wanted. If grown in small pots they may be used to great advantage for the decoration of apartments, and should they not be required for this purpose, they are equally serviceable for cutting.

P. GRANDIFOLIUS.—This plant seems to have been introduced into this country from the gardens of China, where it appears to have been cultivated for a long time, and I am not aware that it has ever been sent to us from a locality where it is found in a wild state. It is a fine plant, producing large, plaited, evergreen leaves, which are from 1 to 3 feet in length, broadest in the middle, and tapering to a long point; the flower-spike is about as long as the leaves, but erect, not spreading like them, and therefore shows well above them. The flowers are large and numerous; the sepals and petals brown tinged with yellow; the lip large, white in front, brown at the base. It continues long in flower, even in a cool house, or in the dwelling house, without injury.

P. WALLICHII.—This resembles the previously named species in general appearance, but is more robust, the leaves are longer when fully developed, and the flowers are also larger. The sepals and petals are of a rich brown suffused with orange yellow; the lip buff in front, but purple towards the base, where it is also tinged with orange. It is a superb old plant for winter and spring decoration, and it also makes a fine exhibition plant, if retarded by keeping it in a cool house without water during winter. Native of the East Indies.

SACCOLABIUM.

The plants comprising this genus rank amongst the gems of the order. All are epiphytes in their native habitats, but under cultivation all the larger-growing kinds thrive best when grown in pots, the only requisites being the most perfect drainage, and a little sphagnum moss to retain moisture about the roots and help to fix them firmly. The moss should be in a living state for these plants, and, indeed, I prefer live sphagnum for all these Orchids which have no peat nor other soil to grow in. Saccolabiums are all natives of the East, and are mostly found in the hottest parts. They require the same temperature and treatment as Vandas. There are many superb species and varieties, but as the majority are summer-bloomers, they cannot be included in these remarks. A small, brown, close-fitting scale is very fond of fastening upon plants of this genus, and if not removed it soon affects their health, and renders them unsightly. Strict attention, and careful washing with soft soap and warm water, I have found the safest and best method of exterminating these pests should they at any time make their appearance.

S. GIGANTEUM until recently was beyond the reach of the majority of Orchid growers, but since its price has become reasonable, no collection should be without it. The leaves of this noble plant are upwards of a foot long, and 3 inches broad, very thick

and fleshy. The racemes are longer than the leaves, and very stout. The sepals and petals are white dotted with lilac, and the lip is of a deep rich violet. The raceme would form a gorgeous head-dress for a lady, especially if backed with a few sprigs of Maiden-hair Fern. It blooms in midwinter, and lasts a very long time in perfection. Native of Burmah.

S. VIOLACEUM.—The leaves of this beautiful kind are usually a foot in length, and about 2 inches broad. It somewhat resembles *S. giganteum* in miniature. The beautiful racemes are about the same length as the leaves, or a little longer, and densely clothed with bloom. The sepals and petals are white, irregularly dotted with mauve and lilac; the lip violet in the centre, mauve at the sides. This plant is somewhat difficult to manage, but amply repays all extra care, as its beautiful and cheering spikes of flower are in perfection during the dullest season of the year. Native of Manilla.

S. HARRISONIANUM.—This differs from the preceding only in the colour of its flowers, which are pure white and very sweet-scented; indeed, it is considered by many a variety of *S. vio-*

laceum, only it blooms during the winter months, and continues several weeks in full beauty if the flowers are not allowed to get damp. It is a native of Pulo-Copang, a little island in the China Sea.

MESOSPINDIUM.

A small genus of Peruvian Orchids, of which one species only, as far as I am aware, is worthy of notice in this place. It succeeds best on a block of wood, and must be grown in the coolest part of the *Odontoglossum* house.

M. SANGUINEUM.—A small-growing plant, resembling very much some of the varieties of *Odontoglossum Alexandriae*. The pseudo-bulbs are small, oval, and compressed, bearing on their summit two strap-shaped leaves. The flower-spike is pendulous, and much longer than the leaves, bearing a profusion of waxy, deep rose-coloured flowers, and as these are produced all through the winter and spring, it is a valuable addition to our cool-house winter-blooming kinds. Native of the Andes of Peru.—**EXPERTO CREDE.**

GROUND LEVELLING AND PRACTICAL GARDEN PLOTTING.—No. 9.

DRAWING PLANS.

To draw and transfer *fig. 32* to the ground, draw the square *ABCD*, and draw the diameter lines *EF* and *GH*, also the diagonal lines *AC* and *BD*. Draw lines 1, 2, 3, 4, 5, 6, 7, 8. From centre *a*, being the point where line 1, 2 crosses the diameter line *GH*, draw arc *c*, meeting the two diagonal lines; also from centre *a* draw arc *b*, as shown by radius *ab*. With radius *ef* draw arc *f*, meeting arc *b* in *d*. With radius *dg* draw arc *g*, meeting arc *b* in *e*. From centre *m*, which is equal to centre *a*, draw the corresponding arcs *b* and *c*, also arc *n*, as shown by radius *mn*. From centre *r* on line 7, 8 draw arc *s*. Arcs *n* and *s* unite where the line is cut, each arc meeting the diagonal line *AC*. From centre *t*, with radius *tu*, draw arc *u*. From centre *o* on line *EF* draw an arc corresponding to *n*, uniting with arc *u*, and meeting arc *n* on the diagonal line. Draw the remaining portion of the plan in the same manner.

To transfer the design to the ground. The base line *AB* is 40 feet long. Find points *ABCD*, as described in *fig. 31*; insert a stake at each point, and lay a line from stake *A* to stake *B*, from stake *B* to stake *C*, from stake *C* to stake *D*, and from stake *D* to stake *A*. Lay the diagonal lines *AC* and *BD*, also the diameter lines *EF* and *GH*. On each side of stake *A* measure 9 feet; insert a peg at each point, as at points 3 and 8. On each side of stake *B* measure 9 feet; insert a peg at each point, as at points 4 and 6. On each side of stake *C* measure

each point, as at 2 and 5. On each side of stake *D* measure 9 feet; insert a peg at each point, as at 1, 7. Lay lines joining points 1, 2, 3, 4, 5, 6, 7, 8; where the lines cross each other, as line 1, 2 and the diameter line *GH*, insert a peg, as at point *a*; also in lines 3, 4 and *GH* insert a peg, as at point *m*; also in 7, 8 and *EF* insert a peg, as at point *o*. From the peg at point *a*, on lines 1, 2 and *GH*, with a string 8 feet 4 inches long, trace arcs *c* and *n*; reduce the string 3 feet 4 inches and trace arc *b* until it meet line 1, 2, as at points *e* and *d*; insert a peg at each point. Radius *c* is 9 feet 9 inches from the peg at point *e*; with a string 9 feet 9 inches long trace arc *f*, meeting arc *b*

in point *d*. Shift the string to peg *d*, and with the same radius as *ef* trace arc *g*, and the bed is traced. Insert pegs 6 or 7 inches apart on the lines traced. The pegs must be put upright into the ground, and exactly in the line traced, so that when the line is laid round the pegs to cut out the bed it will have an equal pressure on all the pegs. By this simple arrangement the beds will be perfect. From the peg in point *m*, on lines 3, 4 and *GH*, trace arcs *b*, *c*; trace arcs *f* and *g* as the corresponding arcs are traced from points *e* and *d* in bed *a*. From point *m* trace arc *n*, as shown by radius *mn*. On line 7, 8, from peg 8 measure 4 feet 8 inches; insert a peg as at

point *r*; from the peg at point *r*, with a string 3 feet 8 inches long trace arc *s*, as shown by the radius *rs*, and uniting with arc *n*, as where the line is cut. On line 3, 4, from peg 3 measure 4 feet 8 inches, insert a peg as at point *t*; from the peg at *t*, with the same radius as *rs*, trace arc *u*. From the peg in centre *o*, with the radius *oc*, trace an arc corresponding to arc *n*, as traced from *m* and uniting with arc *u*, as where the line is cut. From centre *o*, on lines 7, 8 and *EF*, trace arc *c*, as shown by radius *oc*; also from centre *o* trace arc *p*, meeting line 7, 8. Insert a peg at each point, as at points *v* and *y*. From the peg at point *v*, with radius *vw*, trace arc *w*. From the peg at point *y*, with the same radius as *vw*, trace arc *x*. On line 1, 2, from peg 1 measure 4 feet 8 inches, insert a peg as at point *k*; from the peg at point *k*, with a string 3 feet

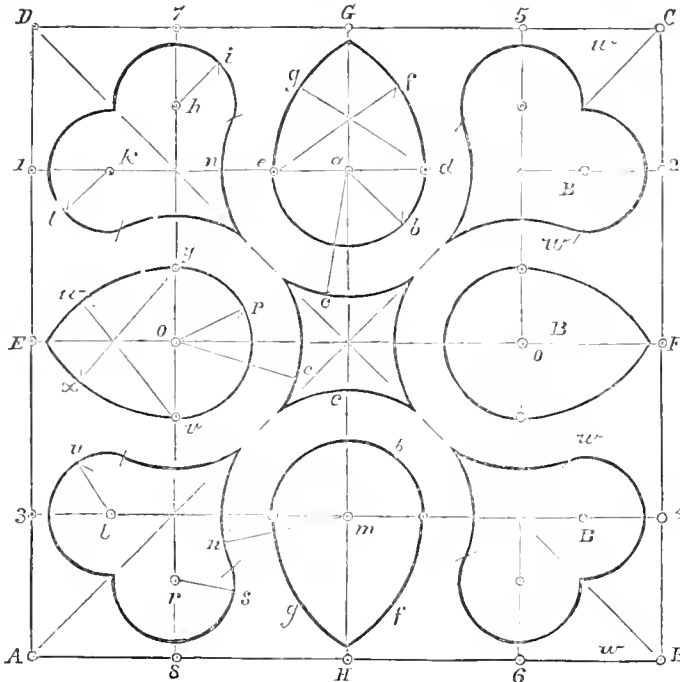

Fig. 32.—Scale 12 feet to the inch.

8 inches long, trace arc *l*, as shown by radius *kl*. From centre *o*, on lines 7, 8 and *EF*, with the same radius as *oc*, trace an arc corresponding to arc *n*, uniting with arc *l*, as where the line is cut. On line 7, 8, from peg 7 measure 4 feet 8 inches, insert a peg as at point *h*. With a string 3 feet 8 inches long trace arc *i*, uniting with arc *n* traced from point *a*, as where the line is cut. The three beds on the diameter line *GH* are now traced, excepting the side of the middle bed not marked *c*; that side is to be traced from centre *o*, bed *B*. The three beds on line 5, 6 are equal to those on line 7, 8, and are traced in the same manner.

As each bed is traced, insert pegs as at first directed. All the beds are intended to have Box-odging.—M. O'DONNELL, *Gardener to E. Leeming, Esq., Spring Grove, Richmond.*

LESSONS OF THE PAST SEASON.

THE long-continued drought of the past summer will cause the year 1870 to be a memorable one. The time of the drought was one of anxiety, care, hard work, and, withal, it was a most interesting time, calculated to rouse one's best efforts to grapple with and to overcome its parching effects; a time of study and watchfulness, teaching us many a lesson for the future, showing us the importance of foresight in preparing to combat the effects of the ever-varying temperature and seasons of our fickle climate. And so before this eventful year becomes numbered with the past and is added to the short tale of our lives, it may be well to record a few of its lessons of usefulness while still fresh in the memory.

First of all, then, comes the important subject of watering; perhaps I shall be more correct if I say water supply, for, alas! the efforts and plans of many an earnest man have been rendered futile owing to the scarcity of water, caused in too many instances by the miserable provision for storing the superabundant moisture, which is suffered to run to waste during those periods of the year when it is given us so lavishly. It is astonishing how few are the gardens which are well supplied with water, or a suitable apparatus for its distribution. It may very reasonably be supposed that, when a new garden is made, so indispensable an aid to the successful development of every kind of crop would receive the attention which its importance merits, but such is not the case. An under-sized cistern, a barrel or two, and a solitary pump, but too often represent the entire provision for storing or supplying water in the driest summer, and this, too, in gardens of considerable size. Now, such a state of things is not reasonable, fair, nor wise, for it is most unfair to expect a man, no matter how clever or persevering he may be, to maintain a regular supply of vegetables, to say nothing of other things, when his best efforts are crippled or rendered unavailing from such a paucity of means.

For those gardens depending in dry weather upon stored-up rain water, a simple, efficient, and by no means expensive apparatus, may be had by building an underground-tank of a size proportionate to that of the garden, into which the water from the buildings and drains should be made to flow. Much water may also be gained by fixing a few gratings along the sides of the garden paths, the gratings to communicate with the drains. Connected with the tank there should be a fixed force-pump to convey a daily supply of water into an elevated cistern of galvanised iron, or wood lined with lead, from which, by means of a hose, the water could be distributed among the crops with much ease, expedition, and economy. Very different is the working of such an apparatus from the more common method of carrying the water in cans, often from a considerable distance. It is all very well to say what a quantity of work a willing man can do in a short time with a pair of cans; but those who advocate such a system can hardly know the labour implied in the unceasing tramp, tramp, throughout the long hot summer's day.

Wherever it is practicable, watering in summer should be immediately followed by mulching, for it is certain that in order that plants should derive any benefit from the application of water, it must come in contact with their roots, so that the spongioles may absorb sufficient moisture to maintain the health and vigour of the plants unchecked. This is, of course, the object of everyone, yet in how many instances where mulching is not used does the water fail to reach the roots even when applied daily, and so the plants linger on without making that marked progress so much desired. The reason for this is a very simple one. The burning rays of the summer sun act with such power on exposed surfaces, as to cause excessive evaporation from all porous bodies, so that the surface soil becomes so dry as to throw off ordinary waterings, it being very rare that enough water is given at one time to thoroughly saturate this dusty surface, which thus effectually prevents the roots from deriving the slightest benefit from the water, which may, and doubtless does, refresh the plants by the moisture playing among the foliage during the process of evaporation, which, as a matter of course, immediately follows. Even this benefit must be a slight one, for the action of the sun is so prompt that its greedy rays quickly evaporate the mois-

ture, and so the plants either struggle on for bare existence or die outright. But how different is the effect of judicious watering when it really reaches the roots, and by the interposition of the friendly mulching the warm moist soil retains the precious store, and the plants flourish with as much vigour as the denizens of a hothed! By way of illustration I will quote an instance of this in my own practice last summer. A quantity of strong plants of *Colens Verschaffeltii* occupying an important position had started nicely into growth when first planted in the beds, but after a time they gradually assumed that standstill appearance which is so tantalising. They had been watered regularly, but on removing the soil about their roots I was convinced that very little water had reached them. I at once set to work and raked the soil away from the stems, exposing some of the roots, and formed a little basin round the base of each plant. These basins were filled with water again and again till the soil was thoroughly saturated; it was then levelled-down and covered with a layer of rough leaf mould, and it was surprising to see the healthy change in the plants visible in a few days.

Mulching is also an important process in the culture of summer vegetables. Early Celery, Cauliflowers, Peas, Tomatoes, and a host of other crops, are much benefited by it. So highly do I esteem it, that I strongly advise its use, especially in small gardens, because—1st, It economises labour. 2nd, It checks evaporation. 3rd, It promotes that quick strong growth so essential in the production of first-class vegetables; and 4th, If it be at all of a rich nature it attracts the roots which it was designed to shelter, and thereby materially assists the crop in the latter stages of its growth.

When taking my last walk round the gardens at Egerton House, on September 21st, I paused to admire a row of British Queen Pea, which was a mass of fine large pods, and there were still a number of flowers along the top of the row. These Peas were sown in a shallow trench on the 3rd of June, they were watered a few times while in their young state, and then thoroughly mulched with some rough manure, and with the best results.

Vegetables generally were very good throughout the summer; the only exceptions were some Peas, and one or two crops of Lettuce. I allude to the Lettuce, because the failure which might have been attributed to the drought had in reality nothing at all to do with it. My rule in the culture of summer Lettuce is, as soon as one crop is visible above ground, to sow another at once. If this be done the requisite supply will be easily maintained. Another good plan is to sow two kinds at the same time. If space can be spared, it is best to sow a few rows thinly, so as to avoid transplanting. However, this cannot always be done, and it was so in my case. Two short rows of Ivery's Nonsuch, and two of Paris Cos, were sown at the same time; when the plants were large enough a number of them were pricked singly into 4-inch pots filled with old hothed manure. When a border could be spared it was made very rich with a liberal mixture of the same kind of manure, and the plants turned out with compact balls a perfect mass of roots. They were well watered, but to my surprise and mortification the Nonsuch all bolted in about a week, and on going to look at those left in the seed rows they were also in the same state. Had it not been for the Paris Cos, which formed fine hearts, a serious gap would have occurred in the supply. The cause of this failure was pretty evident, and after another sowing with the same result, it was quite clear that the seed was worthless.

The first crop of Celery, which came into use early in August, was much assisted by a mulching of short dung, for although it was watered daily, the surface soil became very dry previous to mulching, but afterwards it was always in that moist condition so suitable for this vegetable. Before the first earthing some drain pipes were placed on end along each side of the plants, so that after the earthing one end of each pipe rested on the soil close over the roots, and the other end stood out quite clear of the soil; the water was constantly poured down these pipes to the roots, thus avoiding all chance of wetting the hearts of the plants, or of the water being absorbed by the ever-increasing mass of soil.

From the very poor examples of Celery generally to be seen at horticultural shows in August, and even in September, it is evident very little attention is given to its culture early in the year. This is to be regretted, for I have always found the August Celery as much appreciated, especially for culinary purposes, as the earliest Turnips, concerning which it may not be out of place to say a word or two. If very early

Turnips are required, a crop or two may be brought forward on a gentle hotbed, but generally a first sowing on a cool border under the shelter of a north wall early in March, is soon enough. The method which I have found to answer best, is to sow small beds in the same way as for summer Lettuce—that is, immediately on the appearance of the first crop above ground, to sow another, and so on throughout the summer. This may seem a simple matter, but it is highly important; for the production of a thoroughly good succession of vegetables is an object worthy the ambition of every gardener, and one which is calculated to cause his services to be appreciated.

Another plan to which I have already alluded, and which was of the greatest possible service, is that of potting such things as Lettuce, Cauliflower, Early Dwarf Savoys, and Little Pixie Cabbage. Succession crops of these were constantly brought on in 4-inch pots filled with either leaf mould or old decayed manure. The pots were filled and placed wherever there was a chance of shelter from the midday sun. I remember somebody objecting to it on the score of the amount of labour entailed, but I have found it a saving of both labour and water; even if it were not so, I would still keep to it, because of its certainty. Strong plants turned out into their permanent quarters with such capital balls of roots as these invariably possess are almost certain to succeed.

After giving much attention to the preparation of seed Potatoes during the past two seasons, my deductions are—1st, Always to select the seed at the time of lifting the crop. 2nd, Never to store early or second early sorts in close heaps, otherwise they will sprout quickly, even before winter sets in. 3rd, Never to lay the seed in a damp dark cellar, but always to spread it in single layers if possible, in a cool, tolerably light, airy, frost-proof shed. The Potato crop of this year was most abundant; all kinds attained maturity early, and were lifted and housed in excellent condition altogether free from blight. At Egerton House, even the latest kinds were in the store house by the third week in August, yet when I came into Sussex, a month later, I saw many large breadths in the fields, with very green haulm; in several instances these crops were not lifted till late in October, and a large proportion of blighted tubers was the result. The loss thus incurred was bad enough, to say nothing of a second crop of Turnips, which might very easily have been gained had the Potato crop ripened early in August.—EDWARD LUCKENST, *Old Lands, Buxted, Sussex.*

GROUND VINERIES.

I QUITE agree with what the Editors say at page 457, "Instead of anyone entering largely on ground vineries they would sooner front a wall with glass, where a person could walk inside and attend to the Vines in all weathers." I believe I am stated to be the inventor of ground vineries, but it was only a passing thought, and I never carried out the system, although I went so far as to have a frame made of angle iron, which I see is still in existence, but under which a Vine was never planted. I cannot perceive that the slightest improvement has ever been made on this, the first structure, the four iron legs of which were so contrived as to admit of their being pushed into the earth, so as either to give freedom of ventilation or exclude it altogether. The objections I had to the system were that the Vine would be too confined; that gardeners would not like the stooping position for thinning the berries and foliage; that the bunches could not be seen so well as when the Vine grew upright on each side of a glass structure; and that the Grapes were liable to be mildewed in damp weather by being too near the earth. The only thing I could see in favour of these structures was, that any person could make one for a few shillings.—OBSERVER.

SALES AT COTTAGE-GARDEN SHOWS.

I WRITE in the hope that some of your contributors interested in the subject of cottage flower shows will kindly inform me what is the plan adopted by them with respect to the sale of produce. I act as Secretary for one lately established, and we have adopted the plan of putting up to auction after the show such things as the exhibitors are willing to sell, and this plan seems to answer well enough where the number of articles is small; but when the number of exhibitors is considerable, as it is with us, the sale takes so long that many of the visitors are gone before it is half over, and, besides that, people become tired of continually bidding for Carrots and Potatoes, which

they do not want. The consequence is that the first lots realise much better prices than the last, and the people are dissatisfied. At the same time it seems desirable to afford to the cottagers some opportunity of disposing of their produce, as it gives them a little encouragement, and those coming from a distance, especially, do not care to carry what they exhibit home again.

If anyone can give me a suggestion on the subject I shall feel much obliged.—HORRUS.

THE PURPLE BEECH.

THE various tints which deciduous trees assume when in the eere and yellow leaf have often enough been a theme both in poetry and in prose, but has not the foliage of trees charms at other times as well? Who has traversed London in spring, and not been enchanted by the fresh green foliage of a Laburnum or Wistaria, perhaps growing against the wall of a residence in an uninviting part of the town, where the very freshness of the new-born foliage contrasts so strongly with the smoke-stained objects around? and somehow the leaves look fresher there than they do in the country, where other things are less begrimed. But even foliage affords variety, and certainly quite as many tints in the growing season as in the autumn.

I will now point out one of the most ornamental of all our hardy trees, and ask the reason why it is not planted in greater numbers, for its merits in giving diversity to a landscape are very great.

The Purple Beech has, I believe, been known in England for a great many years, examples of it are often met with in shrubberies and lawns, and in all cases that I am aware of it is appreciated; yet it is but seldom planted, or when it is, some out-of-the-way place is assigned to it, in order that it may with other trees hide unsightly objects. With this I by no means find fault, provided it has an outside berth, so that its branches may have scope in one direction; and its beauties will shine in such a place as well as any other. A tree of this kind grouped with others looks remarkably well, and I would always have one or more Purple Beeches in the front row of any clump or group of trees formed in a park, or wherever ornament was considered—that is, if the soil were at all suitable, and the tree is far from being fastidious in this matter. In May, June, and July, when the country is expected to appear in its best garb, the Purple Beeches, wherever they do exist, are invariably much admired. I do not mean to say an entire plantation would look well, it would be too sombre, but a few trees might be introduced with great advantage.

To those who may be dubious of the Purple Beech attaining the dimensions of a tree I may mention that a specimen in the grounds at Linton Park, planted, I believe, in 1827, is now one of the finest trees we have; branches proceed from its stem at about 5 feet from the ground, and stretch out more than 30 feet in every direction. The spread of its branches in one direction is 73 feet and in another 67, while the circumference of the smallest part of the bole below the branches (and this is above where it had been worked), is 10 feet 10 inches, and the height of the tree must be about 70 feet, the outline being more conical than is usual with Beech trees. The situation, fortunately, is open, so that the branches have had full scope to spread on all sides, the soil dry, and the subsoil accessible to the roots of trees that strike downwards. As this tree has grown very much during the last twenty years, and seems now the picture of health, there is every reason to hope that it will eventually attain, or very nearly so (for it rarely happens fancy varieties do so), the proportions of the common Beech. Even now it may be regarded a good specimen, the colour of its foliage when it first expands being all that could be desired. I may, however, remark that seedlings from it vary much, none I have yet raised being so good as the parent.—J. RONSON.

VEGETABLES FOR THE BESEIGED.—M. Decaisne, Professor of Culture at the Museum, says *Nature*, has laid before the French Institute, of which he is a member, a scheme for the early growing of Cabbages, Radishes, &c., which are to be sown in land richly manured, kept for a fortnight, and used stem and root, as a new description of vegetable. This diet is intended to protect Parisians against scurvy when the use of salt beef becomes still more frequent than it is now. The working of this scheme is superintended by M. Joigneaux, the editor of

several agricultural papers. Different pieces of waste land close to the walls were appropriated, and vegetables of that description must be now actually on sale.

CHRYSANTHEMUM SEEDLINGS.

ALLOW me to suggest to those who purpose raising new Chrysanthemums, that a good scarlet is still a desideratum. The analogy of the colours which prevail in the Dahlia and the Chrysanthemum encourages a hope that this desideratum may yet be obtained; and, indeed, in the Anemone-flowered Firefly we have already the dull beginning of what may end in a vivid scarlet. With respect to the analogy noted above, I would add that both in the Dahlia and the Chrysanthemum we find particoloured flowers very common, and also that the white selfs can hardly be depended on, as they are peculiarly liable to assume a pinkish or other tinge.—G. S.

PLANTING FLOWER BEDS.

In the Journal of September 8th was an account from three sisters of the way in which they had planted their flower beds this last season. Their arrangements were so good that they left but little room for improvement. Mine, on the contrary, were far from satisfactory, and if any kind critic will suggest fresh ideas I shall be most grateful. The beds are seventeen in number; they are all edged with Box, which is kept in nice close order, and there are gravel paths between the beds.

No. 1 has in the centre a plant of Pampas Grass, and as it is of a feathery nature the height is no objection, as it does

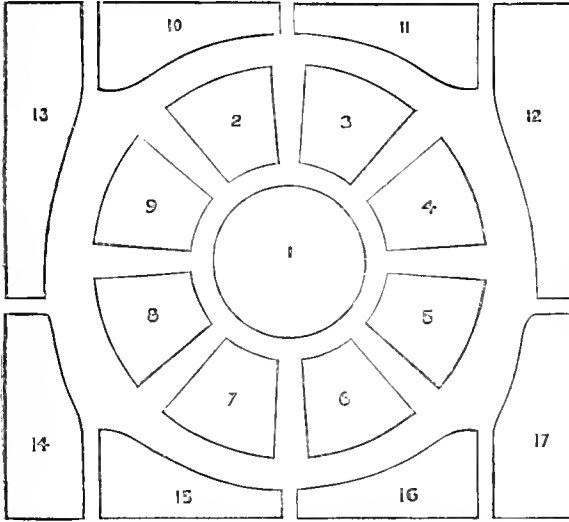

not obstruct our extensive and beautiful view. Round the Pampas Grass was a circle of *Ageratum coelestinum*, then one of *Iresine Herbstii*, then double Tom Thumb Geranium, and finally, next the edge, *Pyrethrum*. The double Tom Thumb goes too much to foliage, and the *Iresine* did not succeed well until late in the season, otherwise this bed was not ineffective. Nos. 2 to 9 were all bordered with *Lobelia speciosa*, and during the short time they were in full bloom the effect of the rich blue next the brilliant green of the young Box was a decided success. Next year I thought of putting *Lobelia* in alternate plants of cuttings and seedlings, as the latter flower when the former are over. Nos. 2 and 6 were filled in with *Calceolaria Aurea floribunda*; No. 3 with *Geranium Stella*; No. 4 with *Mrs. Pollock*; No. 5 with *Madame Vaucher*; No. 7 with *St. Clair* and *Bijou*; No. 8 with *Crystal Palace Gem*; and No. 9 with *Le Grand*. Of these beds, Nos. 4, 8, and 9 did best. Nos. 10 and 16 were mixed *Verbenas* pegged down, and producing an excellent effect. No. 11 was *Tropaeolum Moor*, and No. 15 *Tropaeolum luteum*. No. 12 was the worst bed in the whole garden, although I had expended much anxious thought on its arrangement. It is the bed which is of the most consequence too, for the drawing-room window immediately overlooks it. The outside edge was *Purple King Verbena*, then a row of *Excellent Geranium*, then *Heliotropes* of different shades, and the centre filled in with *Balsame*. No. 13 was

likewise a failure. The two outside edges were common *Scarlet Geraniums*, and the centre filled with *Phlox Drummondii* of different colours. No. 14 was *Cineraria maritima* and *Centaurea*, arranged in two rows alternating with *Christine Geranium*. No. 17 was a bed of mixed *Petunias*, most of them having done well.

I have not drawn the beds outside the circle quite correctly, as they should be narrower and longer, Nos. 12 and 13 being much larger than the others. They are all in such a compact space (about 20 yards square), that the arrangement of height is quite as necessary as that of colour; any hints, therefore, from a practical gardener will be most valuable.—*IGNORAMUS, Hampshire.*

[We cannot do better at present than just refer you to the letter and plan of the three sisters of September 8th to which you allude, and to the answer and observations made on it. We should judge better of your group if we knew how it was to be viewed, whether on a level with or below the surrounding ground. In either case, but especially in the former, if the garden is to form one view or picture, then the size of the beds and of the plants becomes important. In such a case the central bed is too large, and to prevent its drowning the others you plant it in rings of colour; but, on the principle referred to, if the garden is to be viewed as one picture, then we object to the centre being a Pampas Grass, as it will be lumpy and a green mass all the time the other plants are in full bloom, and too high and massive even then.]

There are two ways of making an artistic view, so far as heights are concerned, in such a garden. The first is to have the central bed rather the highest, and the outside beds the lowest, the intermediate ones suiting in height. And the second plan would be the reverse, to have the highest outside and the lowest in the centre. We allude to these arrangements merely for convenience as respects plants, as it would be best of all if the beds, except at the edges, were of a uniform height. A few more elevated stand points might be useful for preventing the level sameness.

You seem to have commenced on the first principle by having the Pampas Grass in the centre of the central bed, followed by tall *Ageratum*, *Iresine Herbstii*, and *Double Tom Thumb*, bordered with *Pyrethrum*. Even with similar plants we think it would have been more effective with a suitable pink or scarlet *Geranium* following the *Ageratum*, and the *Iresine* or *Purple King Verbena* between the *Geranium* and the edging. But for the Pampas Grass, many other arrangements might be made. The bordering with *Pyrethrum* makes the edging of the eight beds round it very suitable and striking from its very simplicity.

Your object is to plant these eight beds in pairs on the cross system, and therefore the whole garden should be planted on the cross system. Thus, if 2 and 6 are to be pair beds, then 13 and 17 ought also to be pair beds. Looking at the planting of these eight beds, we find *Aurea floribunda Calceolaria*, *Madame Vaucher Geranium*, *Crystal Palace Gem Geranium*, and *Mrs. Pollock Geranium* would all harmonise in size and suit admirably, but then your *Geraniums* must grow very differently from ours if *Stella* and *St. Clair* in 3 and 7 did not grow in height far above all the others. Such dwarf kinds as *Lady Cowper*, *Little David*, *Harkaway*, &c., would be more suitable for the neighbour beds, and a band of *Bijou* or *Alma* inside of the blue *Lobelia* would relieve well and enhance the beauty. With the central bed lower, and these eight beds well planted and tended, the nine beds would of themselves make a pretty symmetrical garden.

We need not enter on the other beds. Mixed *Verbenas* always look well, especially if they have an edging to keep them in bounds. *Balsams* do best in a border or small beds, where there is room to show off their blooms, and not in the centre of a bed. Besides, their blooming is rather late and irregular, and in height they and *Phlox Drummondii* and seedling *Petunias* would be higher than the ring of eight beds. Such plants are not to be depended on for neatness and effect like *Geraniums* and *Calceolarias*. If such plants must be used, we would make the central bed the lowest, and instead of a Pampas Grass have a statue or an elevated vase in the centre. Then, for uniformity, as you edge the eight central beds with blue, we would edge the other eight with white; say 10, 11, 15, 16 with *Cineraria maritima*, and 12, 13, 14, 17 with *Centaurea*, or the first four might be done with *Bijou* or *Alma Geraniums*, and the next four—two of *Centaurea* and two of *Cineraria*. If these large outside beds were filled with low-growing plants, then low white and yellow variegated *Arabic*

would form compact edgings, or even *Cerastiums*, and then the *Centaurea* and *Cineraria* could come in for centres, or intermediate rows between scarlets or purples.

You state that 12 and 13 are much larger than they are represented in the sketch. As given, even, they are so much larger than the other pair of beds that unity in size is destroyed. We do not see your object in thus bringing out these two clumps with such a long tail, unless you wished to avoid the pathway between them being directly opposite the pathway in the eight corner beds. We would avoid this, and have these beds similar in size by having a circle between them. We would be inclined to do the same between 10 and 11, and 15 and 16. The whole group would then be more regular and equally balanced.—R. F.]

IMPERFECT HYBRIDITY.

AMONG the same batch of seedlings from which I obtained *Veronica Andersoni* (*V. salicifolia*—syn. *V. Lindleyana*, with *V. speciosa*) came one which, to all appearance, was a reproduction of the male parent pure and simple. And, deeming it nothing else, I presented it to a friend, *V. speciosa* being then comparatively a new plant; and he, when he flowered it, came to tell me that it had come a very different thing when in bloom from the true *V. speciosa*, having much longer flower-spikes, and being of a much lighter colour than those in that species—that is, of a light crimson instead of a dark purple as in the *V. speciosa*.

A plant of this hybrid has since afforded a further illustration of a somewhat similar result.

Having obtained a suffruticose species of *Veronica* under the name of *x V. Danbenyana*, with light-coloured flowers streaked with pink lines, in the way of *V. fruticulosa*, I crossed it on the last-mentioned hybrid, which became the seed-bearer. From this cross I succeeded in raising only two plants, and one of these I believe I have lost. But they seemed both alike in foliage and habit, but both so like the hybrid seed-bearer that I felt doubtful whether the cross had taken. I cannot speak with confidence as to their being identically alike, but only of their general aspect. The plant I still possess flowered for the first time this past season, and the singularity of its bloom drew my attention to it more particularly than before. It had, like the seed-bearer, thick, fleshy, oblong leaves, but somewhat smaller and more closely set on the stem; but instead of being, like it, simply crassiform [?], they were obliquely decussate, therein slightly approaching the male parent, a creeping alpine species, whose prostrate stems show still more the same deflected arrangement of the leaves. It was only on a close examination of the parts, however, that any resemblance to the male, *x V. Danbenyana*, could be observed. In fact, I looked upon it as another of the many failures I had had in my attempts to effect the inverse cross on it. When it at last bloomed my hopes of having effected a partial cross, if I may use such a term, were strengthened. Like *x V. Danbenyana*, which has a spikelet with a few blooms, it came even short of it, having had only two flowers, and these much lighter in colour, and so nearer to the male than the hybrid female parent. But whether this is its true permanent character I dare not assert, as it bore no more than this one spikelet of two flowers.

In the first of the above instances the hybrid seemed, till it flowered, a repetition of the male parent; in the second it seemed, till it bloomed, a repetition of the female parent, with such slight differences in the arrangement and slightly smaller size of the foliage as might occur in a purely normal seedling. In fact, seldom have I ever seen two hybrids with so much of one parent and so little of the other.

I have no doubt something of the same kind occurs among *Rhododendrons*; but I may only instance two cases—one where I crossed *R. Edgeworthii* on *R. canescens*; the seedlings, always few when the cross is a severe one (by which term I mean such instances as where the species do not affect each other kindly), were only two in number; and though now about ten years old, they show no indications of setting for flower. But while they have both the glabrous foliage of the seed-bearer, and even the ochraceous tint underneath, they differ in having oblong instead of its lanceolate leaves. But, though in these particulars they depart from the normal state of *R. canescens*, they have not one feature of *R. Edgeworthii*, the male parent. The other case is where I crossed the same, *Rhododendron Edgeworthii* on *R. Jenkinsii*. Here the seedlings, again only two in number, were all of the mother, except by having again the oblong foliage, in which, he it observed, it is a departure from both parents, both having lanceolate leaves—those of *R. Jenkinsii* being acutely so, but the hybrid in these latter cases is budded for flower, but the flowers of both parents are white, and both sweet-scented, and both among the largest of the genus; the scents, texture, and forms of the flowers are different, so that I look for surer tests in the coming flowers—though these may be perplexing too—than any that yet appears. It is proper to observe that I take the utmost precaution, in all my crossing operations, to prevent miscarriage in any possible way.

While treating of my difficulties with the *Rhododendron Edgeworthii*, one of the most peculiarly constituted, as it is one of the most peculiarly featured, of all the *Rhododendron* tribe—having its rugose leaves densely pubescent on the upper, while it is perfectly shaggy with

tomentum on the under side, every stem being clothed with the same tomentum—I have another most singular peculiarity to note in regard to it, viz., that while it will cross other species, it will take on a cross from none; that is to say, while it has been repeatedly made the male, it has never with me, though I have tried it often, nor with anyone else that I have heard of, submitted to become the female parent. I have crossed it repeatedly on *Rhododendron ciliatum*, one of the minor forms, too, of *Dr. Hooker's Himalayan species*. It has been crossed on *R. formosum* in this neighbourhood, I believe in the *Stunwell Nursery*, but I never could get it to take on any cross whatever. *Rhododendron Nuttallii* behaved with me in the same manner; it would cross but not be crossed. But I did not persevere with it as I did with *R. Edgeworthii*. Now, I do not assert absolutely that *Rhododendron Edgeworthii*, in the numerous tribe of which it is a member, may not be hybridised with some other of its kindred, but I could never get it to reciprocate a cross.

And this remarkable circumstance of non-reciprocity has perplexed and defied me in innumerable instances throughout my long experience in these pursuits. It occurs to me that the pollen of larger forms might be of larger grains, and so might not pass through the necessarily small ducts of the styles of smaller species. Yet *Rhododendron ciliatum*, a tiny species of 1 foot high, was crossed freely by *R. Edgeworthii*, as I have just noticed—a species 6 feet high. I even crossed this latter species on a pure Indian *Azalea*, though, by pulling the seed-pod before it was ripe, I raised no seeds of this latter cross.

In these hasty observations I merely wish to direct attention to such instances of imperfect hybridity in certain species, and the non-reciprocity in others, as I have noticed, in the hope of perhaps drawing out from others their experience on such matters, which I humbly think are not unworthy the consideration of the Scientific Committee.—E. ANDERSON-HENRY—*Read at the last meeting of the Scientific Committee of the Royal Horticultural Society.*

GARDENERS' PRIZES FOR VEGETABLES AT

THE ROYAL HORTICULTURAL SOCIETY'S NOTTINGHAM SHOW.

At a meeting of a committee of gardeners, held at Stamford, for the purpose of carrying out Mr. Gilbert's scheme for gardeners' prizes for vegetables at the Royal Horticultural Society's forthcoming Show at Nottingham, Mr. Smith, of Exton Park, was appointed Honorary Secretary and Treasurer; and as it is necessary that the amount required (£20), should be collected without delay, in order that the prizes may be placed at the disposal of the Society in time for the issue of the local prize schedule, it is requested that all gardeners desiring to subscribe will at once send their subscriptions to Mr. James Smith, Exton Park Gardens, Oakham; post-office orders to be payable at Oakham.

It was determined at the meeting that the amount should be divided into three prizes, of the respective values of £10, £6, and £4, to be given either in watches or money, at the option of the winners. An offer by Mr. Chapman, of Gloucester, of one of his patent exhibiting cases as a further prize, was accepted. The following subscriptions have been received by the Honorary Secretary and Treasurer:—

	£	s.	d.
Gilbert, Mr., Burghley Park, Stamford	0	5	0
Smith, Mr., Exton Park, Oakham	0	5	0
Caldar, Mr., Casewick, Stamford	0	5	0
Easton, Mr., gardener to T. Laxton, Esq., Stamford	0	5	0
Meiken, Mr., Reed Hall, Whalley	0	5	0
Peasey, Mr., Quorn Lodge, Loughborough	0	5	0
Taylor, Mr., Longlet Gardens, Wramster	0	5	0
Mitchell, Mr., Ruddington Hall, Nottingham	0	5	0

CYCLAMEN SEEDLINGS BLOOMING WHEN TEN MONTHS OLD.

ONE of your contributors (page 467) says that *Cyclamens* exhibited at the Royal Horticultural Society were grown from seed, and flowered fit for exhibition in ten months. How is it to be done? I should certainly be glad to know.

I sowed seeds of the Persian *Cyclamen* on the 10th of March last, pricked them out into small pots when large enough to handle, and repotted them in August. They now look very healthy, but they are very small, and I fear will show but little bloom even twelve months hence. I am a great admirer of that beautiful flower the Persian *Cyclamen*, and should be pleased to be able to grow it more quickly, and so, I doubt not, would be a great many more of your readers.—W. SCOTT.

[We wish some of our readers would detail the mode of so hastening the *Cyclamen* seedling's flowering.—EDS.]

"PEAS IN DECEMBER—ICE IN JUNE"—were the wonders of our ancestors, but with us are no rarities. One instance is now before us. Mr. Bannister in his garden, on St. Boniface Terrace, Ventnor, Isle of Wight, gathered a dish of green Peas

on the 7th inst., and unless more severe weather sets in he is confident of being able to do so at Christmas.

MIMETIC ANALOGY.

The following is an extract from notes read by Mr. Murray at the last meeting of the Scientific Committee of the Royal Horticultural Society.

"Although mimicry occurs between various tribes or genera, it has been observed most frequently in connection with the most common species of the country. This is what would naturally be the case with hybridisation, supposing all to start fair, and to be equally liable to hybridisation. But this is an assumption which we are scarcely warranted in making, and I therefore do not press this inference further than as of some conditional value.

"After the second generation of hybrids, those which do not revert to the type break out into an overflow of irregular variation, which supplies many of his most remarkable sports to the horticulturist, and many of his most puzzling difficulties to the systematic botanist. On the assumption that the mimicry in question is the result of hybridisation, we should therefore expect to find a marked degree of variation among the mimicking species. And so we do."

Mr. Murray cited evidence on this head, and then continued:—

"It seems a fair inference that when the mimicking species are not variable, they have been established before the second generation of hybrids, and where they are variable they have been established subsequent to the second generation, and have experienced the usual shock to stability occasioned by such repeated loosenings of the fetters of specific identity.

"Mr. Bates' list of mimics and mimicked species shows, too, that when a species is mimicked by one species or genus it is often mimicked by more—a fact which, applied to the idea of hybridisation, simply means that that species had a readiness to take to itself wives of more than one of the nations round about. It is only what we find in plants—that some are more open to hybridisation than others, or perhaps analogous to our moral experience, that where scope is allowed to our own passions, license soon degenerates into libertinism.

"Another feature familiar to all hybridisers occurs in these mimicries. Notwithstanding the statement of Whicura to the contrary, it is now perfectly well known that in attempting to obtain a cross between two species, we often fail when we work with the male of one species and the female of another, while we succeed when we reverse the process, and take the male of the latter and the female of the former. In plants, the cases where this capability of crossing in only one direction occurs are beyond numbering. Mr. Isaac Anderson-Henry cites many of them in his late Presidential address to the Botanic Society of Edinburgh, and in the paper which I have now the pleasure to lay before the meeting. The very same thing has occurred with the mimicries recorded by Mr. Bates. They are all on one side of the house. The case which so often occurs in plants has obviously occurred among the butterflies. The cross has taken only from one side—which is it? Judging from the example of the mule it should be on the side of highest organisation; that is, that the male parent has been of the lower organisation, and the female parent (the actual bringer-forth) of the higher. Now, which is the side of highest organisation in the Danaids and Pieridae—is it that of greatest strength? If it were so, it would then be the Danaids, for they are larger, finer, and more powerful than the more northern whites. But organisation is a higher test than mere strength, and an advance in it is doubtless what must be the unconscious aim of the ambitious match-seeker. This, too, seems to be on the side of the Brazilian tribe. Mr. Bates so considers it, and his reason is that the essential quality of butterflies being flight, the type which has most attention paid to its wings and least to its legs must be highest of its order. Others think differently, and say that a type which has had two of its limbs (its fore legs) almost atrophied cannot be so perfect an animal as one which has them all in perfection. But I agree with Mr. Bates on this point (at all events in his conclusion). The greater number of legs cannot be any indication of higher organisation, or a centipede might dispute supremacy with ourselves, and push us from our stools. The fewer limbs, that is, the simpler the apparatus that a creature can do its work with, the higher the perfection of the machine. Therefore, doubtless, the cross from which these mimics resulted was one by the males of the whites upon the females of the Danaids.

"Now what does plant-hybridisation tell us on this point? What does Mr. Henry say? I regret to differ from so great an authority as Whicura (who had maintained that 'the products which arise from reciprocal crossing in plants, unlike those which are formed among animals, are perfectly alike'), and must venture to demur to the doctrine in more decided terms than Mr. Berkeley has done. I have had so many instances of hybrids taking sometimes to one side and sometimes to another—but most frequently to that of the mother—that to those who, like me, have tried their hand with many genera, it would be a matter of supererogation to give instances. I have had them by the score."

"But the mixed product also corresponds with another fact observed in hybridisation. Mr. Henry informs me that in some of his crossings of plants he has only succeeded in altering the flower, the foliage continuing persist the same as that of one of the parents. He

has not succeeded in distributing the notion through all parts. That is exactly parallel to what we see in these mimicries. In plants it may be a question whether we should consider the flower or the foliage as the more structural parts; for my part I should take the flower as the more important, and therefore equivalent to the structure of the legs and wings, and the foliage and habit of the plant as equivalent to the colour and form of the wings, and general appearance of the insect. In Mr. Anderson-Henry's case another phase of the mimicry, which I have no doubt will be found to have also its parallel in the hybridisation of plants, although I am not able to cite any instances exactly in point, is, that in species which have dissimilar sexes it sometimes extends to both sexes, the males being like the males and the females like the females, but in other instances is confined to the females. I believe that the reason why I have no case in point to cite in plants is, that it can only be had in dioecious plants; and the hybridisation of dioecious plants has hitherto been scarcely at all attended to. Mr. Henry has some coming forward, but they have not yet flowered.

"The last point to be noticed is one of some importance, as being the only one furnishing a shadow of objection to the explanation of the mimicries in question by hybridisation. It is, that the nearest natural allies of both the mimickers and mimicked are not always to be found in the same district as them. This deserves the more attention, that it appeared so strong to Mr. Bates as to lead him to relinquish the idea of hybridisation as an explanation after it had crossed his mind.

"Before I proceed to show how simple the explanation of the absence of one of the parents is, I must beg to note, in passing, the admission that there are distinct forms whose intercrossing would produce the hybrids. That granted, I would remind the reader of what Mr. Bates has obviously overlooked, that we are dealing with a phenomenon, probably of a very ancient date, and that one side of the parental stock may have disappeared in the course of time. One of the parents we know to be present (the so-called mimicked), but there are excellent reasons, based on climatal considerations, why the other parent should not be present.

"There is yet another phenomenon connected with mimicry, which possibly may also be connected with hybridisation—viz., the occurrence of what Mr. Wallace has called dimorphism in insects among the mimicking or mimicked species. We must not, however, confound this dimorphism with Darwin's dimorphism in plants. The two are totally different things, and, as it seems to me, have no relation or analogy to each other. In plants the dimorphism is always confined to the reproductive organs, in insects it has apparently nothing to do with them. Moreover, it seems to me that all the instances of so-called dimorphism in insects that have yet been recorded are nothing but examples of variation, perhaps complicated by hybridisation."

ENTOMOLOGICAL SOCIETY'S MEETING.

The second meeting of the present season was held on the 21st of November, the President, A. R. Wallace, Esq., in the chair. Amongst the donations to the Society's library were the publications of the Entomological Societies of St. Petersburg and Italy, the Royal Society of London; and a memoir on the cultivation of silk in the Australian Colonies by Captain Hutton, published at Calcutta during the present year.

Mr. F. Bond exhibited *Fumea reticella*, male and female, the latter distinguished by the absence of wool on the terminal segment of the body; also *Aecialia strigaria* and *Physcia obductella*, all taken near Gravesend by Mr. Button. Mr. Albert Muller exhibited a specimen of the large fleshy larva of the Longicorn Beetle, *Egosoma scabricorne*, which infests the trunks of Lime trees in the great square of Basle in Switzerland. Mr. Frederick Smith sent a number of specimens of a small dipterous insect, *Phora florea*, the larvæ of which infest the interior of the bodies of the larvæ and pupæ of the common Wasp, as many as fourteen having been found in a single Wasp-grah; and out of a comb of 200 or 300 cells, only a few Wasps escaped the attacks of this little insidious fly.

Mr. Butler read a memoir containing descriptions of new exotic species of Butterflies of the families Nymphalidae and Hesperidae in the collection of the British Museum from Venezuela, and in Mr. Dawe's collection from the Kaden Museum.

Mr. F. Bond stated that at the late exhibition of the Haggerstone Entomological Society he had observed a singular specimen of *Vanessa Atalanta*, having the head of the larva remaining upon and concealing the head of the Butterfly; also a curious specimen of the common Brimstone Butterfly, having the wings streaked with the colours of the opposite sex.

Professor Westwood stated that he had recently reared a number of specimens of *Phloiotribus Oleæ* from the stem of an Ash tree imported from France. It had hitherto only been reared from the Olive tree in the south of France.

BEECH FOR CHALKY SOIL.

Will you permit me to say that you are perfectly correct in recommending to your correspondent to plant Beech trees in a chalky soil? I am at present residing in a locality where there is nothing but chalk, and the Beech trees grow magnificently;

indeed, it seems to be their natural "habitat." It is interesting to the naturalist to watch the great numbers of the "pied finch" which feed upon the nuts when they fall upon the ground. Alas! it is equally to be regretted, that in this district, where the thrush and blackbird abounded so much as first to attract me favourably to the locality a few years ago, scarcely a bird exists to welcome in the approaching spring. Surely something might be done to stay the wanton destruction of our British birds.—HORTICULTURER.

IRON GRATINGS FOR BOTTOMS OF MUSHROOM BEDS.

HAVE any of your readers ever used iron gratings for the bottoms of Mushroom beds? I saw them in use some ten years ago at Hardingstone, at the residence of the late Mr. W. H. Barwell, iron-founder, of Northampton. The gratings were of cast iron, made to the width required, and were used for the bottoms of the beds instead of boards. In making up the beds turf was first placed on the grating grass side downwards, and the beds were filled up with droppings and spawned in the usual way; the result was that as many Mushrooms came through the grating at the bottom as on the top of the bed, thus giving a double crop. When I saw them the bed was completely covered, top and bottom, with Mushrooms of all sizes, some of them 6 or 7 inches in diameter. The spawn used was taken from a hovel on the premises which had been used by cows and horses in the winter and spring before, and as the material was undisturbed all the summer it was found in the autumn to be a whole mass of spawn.—H. HARRIS, *Gardener, Naseby Woolleys.*

[We have met with such Mushroom-bed bottoms, and doing well. We know of no objection except the rusting of the iron. That could be avoided by placing the pieces of grating in a galvanising trough, but we are not aware how long the galvanising would stand the steam from the dung. We should have no objection to such a house being all iron inside. When wood is used we prefer the bottom of the beds to be sparrow instead of close, as in the former case they are more easily influenced by the heat from the bed beneath. We have frequently thus had double crops, but in shallow beds we thought the crop on the upper surface was sooner exhausted.]

PORTRAIT OF MR. RIVERS.

THE following additional subscriptions have been received:—

	£	s.	d.
Hanbury, Robert, Esq., The Poles, Ware	2	2	0
Matheson, Sir James, Stornoway Castle	2	2	0

WORK FOR THE WEEK.

KITCHEN GARDEN

In most gardens in the country leaves can be collected, and when properly managed they form, perhaps, the most useful source of bottom heat with which we are acquainted, except, of course, the tank. All the leaves necessary for carrying on the business of the ensuing year should be collected as early as possible in the autumn, and be placed close together to ferment. After fermenting for three weeks or a month they are in excellent order for use; in this state they will both heat with more certainty and tread more closely. In order to be ready for forcing of all kinds, to form powerful linings, or to build new beds, it is necessary to have at hand a mixture of hot dung and leaves. In the course of this month, therefore, the whole of the hot dung should be drawn from the stable yard to the leaf yard, and immediately thrown together and well watered in order to dispel the fiery heat. When fermented thus for a week or so, it may be mixed with leaves. About four parts of the leaves to one part of hot manure will make a powerful and enduring mixture, and in most cases provide a bulk of material which will carry on all the hotbed and lining work for two months to come. Thus provided, a gardener can make up a frame or pit at any time, or furnish new linings, at a couple of hours' notice; for if the dung has had one powerful heating previous to its being mixed with the leaves, little danger need be apprehended from impure vapours, provided the most ordinary precautions be observed. The wet weather we have experienced will, in some situations, have greatly retarded much that would otherwise have been done; it is therefore necessary

to forward all that can be done within-doors, so that there will be no hindrance to out-door work when the weather becomes fine. There are numerous operations which can be performed by labourers within-doors, and which, if not immediately necessary, may at some time reduce labour when most wanted. The making of labels, brooms, flower-sticks, shreds, &c., is usually done in bad weather, also the cleaving of wood. Take advantage of a dry day to lay tiles over some of the *Endive* in the open ground; take up a portion of the best, and lay it in a frame or shed as a reserve in case of severe frost. In favourable situations, where neither forcing-houses nor pits are at command, another sowing of *Peas* and *Beans* may be made, but where a common frame can be spared till March it is far preferable to sow in pots. *Radishes* sown in frames must have air as soon as they make their appearance, if the weather permit.

FRUIT GARDEN.

Proceed with pruning and nailing as opportunity offers. Apples, Pears, Plums, Cherries, Gooseberries, Currants, Raspberries, and Grape Vines should all be proceeded with. All spare nails should now be drawn from the Peaches, Nectarines, and Apricots. They should be sorted, dried, and cleaned ready for immediate use.

FLOWER GARDEN.

Go on according to the advice of last week. Take the first opportunity, when fine weather sets in, of carefully looking over Carnation layers that are in frames. It is possible that soil may have settled in the axils of the leaves; as this retains moisture in a very inconvenient degree, it is highly necessary for the health of the plants that it should be removed. With respect to Ranunculuses, lose no time in making purchases, and take care during this rather variable weather that the roots do not contract mouldiness, which is fatal to them. In concluding my directions for the present year I would counsel all cultivators of florists' flowers, and especially those who are about commencing, always to bear in mind that quality is preferable to quantity, and that it is the best policy to purchase good strains and good sorts.

GREENHOUSE AND CONSERVATORY.

Keep as moderate a temperature as possible when the Camellias are in bloom, in order to prolong their season. Drip is generally found inconvenient during a frost, and it may be advisable to withhold water altogether for a few days; or cover the roof with a canvas screen, which, by preventing condensation through a low roof temperature, will accomplish the object more effectually. The conservatory should now be very gay, and, if former directions have been attended to, some of the finer kinds of *Azalea indica* will be developing their charms—such as *Exquisita*, *Coronata*, *Carminata*, *Variegata*, *Lactaria*, and *Gleditsiana*; with these there may be a few *Ixoras*, *Allamandas*, and some other stove plants, several kinds of *Chorozemas*, *Boronia pinnata*, *Styphelia tubiflora*, a few kinds of *Heaths* and *Epacrises*, and some minor softwooded plants. In the greenhouse look well to plants in a growing state, such as *Dioscoreas*, *Pimeleas*, &c. Remove the bloom as fast as it appears; but those plants of the former which are intended for early blooming must not have their flowers removed after the first week in January.

STOVE.

Here all is still and quiet. Keep up a moderate heat of from 50° to 60°, and give plenty of air. The *Ixoras* should be elevated near the glass to set their bloom, and have plenty of air at all times. Keep them comparatively dry. *Stephanotis*, *Allamandas*, &c., may be potted and trained preparatory to starting after Christmas, and the staking of all specimen plants must be proceeded with as fast as possible. It will soon be time to commence potting *Orchids*. Let a stock of proper materials be provided without delay. Free fibrous heath soil cut into squares about the size of walnuts, fresh sphagnum chopped or cut, plenty of broken crocks, charcoal in lumps, and some chopped sticks (avoiding Fir wood), will all be found necessary. The whole of these materials, except the crocks and charcoal, should be subjected to some process that will destroy snails and other insects, with their eggs. The sphagnum and heath are generally scalded, but from experience an objection is taken to this, as the process so much hastens decomposition in the vegetable matter that it soon becomes a pulpy mass impervious to the atmosphere. It is better to lay it in some warm and dry place, turning it occasionally.

FORCING PIT.

Introduce such plants as are generally used for forcing,

especially the sweet-scented subjects, as Lily of the Valley, Sweet Briar, and Lilacs, and do not forget to introduce a good batch of Roses, choosing the most promising plants of Texas, Bourbon, and Hybrid Perpetuals, which are the best kinds for winter flowering. A gentle bottom heat will be of great service to these, also to most other plants subjected to heat, in order to flower them as quickly as possible, and a moist state of the atmosphere must be secured, admitting a little air freely at every favourable opportunity. Dutch bulbs should be largely used for forcing at this season, and when hardy shrubs are forced for the decoration of the conservatory, these should be brought into bloom as soon as circumstances admit. Some persons, however, think that it is worse than waste of time and space to force such common things as Rhododendrons, Azaleas, and other American plants, as, with equal care and no more expense, much finer flowers may be had at this season without forcing. All forcing plants intended for succession should be under a temporary covering of some kind—an open shed is as good a place as they can be put in, or under the stages of a greenhouse.

PITS AND FRAMES.

Give plenty of air to Violets, Mignonette, and Intermediate Stocks in frames or pits. Avoid watering as much as possible; it is better to let the plants flag a little than to have the soil too much saturated at the roots.—W. KEANE.

DOINGS OF THE LAST WEEK.

KITCHEN GARDEN.

LITTLE has been done here excepting covering Celery in frosty nights, clearing breaks of old Cabbage plants, and spreading a little manure and material from the rubbish heap on the bed, to encourage the sprouts until the spring, as they help to keep us from going so often to the early Cabbage quarter. Drew a little more earth to the strong early Cabbages, as it keeps them firmer and more secure from frost. Put some old sashes over a fine late bed of Radishes in an earth pit, to protect them from severe frost and wet. The rains of late have been so heavy that we have done but little on our heavy ground, but when the weather was fair we collected a lot of tree leaves, though we would rather have had them dry, but when dry weather comes there will be groundwork demanding attention. Turned over manure heaps intended for Mushroom-beds, for which we must have them dung rather short and moist, saving only a few horse droppings for covering.

There has been plenty of work under cover in wet days—in fact, our wettest days are generally our busiest days, and indoor work is sometimes delayed too long that it may be done in such weather.

Water.—The ponds in many places are filling very slowly, except where there is a great command of surface water; as the ground drains act but little owing to the moisture absorbed by the dry soil. Owing to our now having more piping to buildings, our tanks in the garden are nearly full, and we only wish we had three or four times the space for clean water in reservoirs, as then we could look forward to the summer without alarm. Such a season as last ought to teach many a lesson in dry districts. Good tanks and ponds now would soon pay the expense of horse labour in carting during the summer. We wish the water that has run to waste of late, could be converted into a little lake. Where this has been done in some places, there is no standing still in summer, where formerly there was a constant annoyance about water-carting. Draining is all very well, but it would be a benefit in many places to collect the water from drainage, instead of letting it off as it came to the nearest outfall. Can anyone tell of a cheaper mode of making a fair-sized reservoir than puddling with clay? The worst of clay puddling is, that unless fringed with grass, it is apt to crack in summer, when the water sinks, and then away goes the water. Of course, nothing is better than bricks and cement, but they are expensive. Even large tanks done in the best way will always stand best, if the walls instead of being perpendicular should be bevelled outwards from bottom to top. From inferior cement and inferior workmanship many tanks do not stand well—that is, do not hold water. The finest brick ever burned is useless for such a purpose when used as it comes from the kiln.

FRUIT GARDEN.

The work has been much the same as in previous weeks. We would have done more outside work if we could. We placed all the Strawberry plants under protection; during bad weather

they were previously protected with litter. We shall soon move some from frames into heated pits and houses. We would have done so earlier, but could not obtain runners early last season.

We finished with the Fig house, and hope we have settled the bug that visited us there for the first time; at least, every bit of wood and brickwork was pretty well examined, and treated with water as near the boiling point as possible before lime-washing, painting, &c. We have been told that burning sulphur fumes will settle it, but then the fumes will kill vegetation of every kind that is growing, and can only be used where the wood of deciduous plants is thoroughly ripened, and there is no chance, from openings in divisions between houses, for the fumes to go from an empty house to one where plants are growing. Pruned and cleared a second viney preparatory to filling it with plants.

We have had several inquiries as to the use of

Brick Pits in Forcing Houses, and using fermenting material for starting Vines and Peaches. Where convenient, such pits inside a house are very useful. In the early part of the season they might be used as hotbeds, covered with glass, whilst the general atmosphere of the house was kept comparatively cool. When that was no longer desirable the glass, &c., might be removed, and then how well would the bed come in for plunging pots that would require a little bottom heat! When that was not wanted, and the bed might sink too low, a sparred table or trellis placed over it would be the place on which to set plants thickly, to suit the shaded roof. When none of these uses are required, and Vines and Peaches are to be forced, then these pits filled with fermenting material will be one of the best modes for softening and breaking the buds. When rank dung is used for this purpose, then no evergreen plant and no deciduous plant, unless when in a state of rest, ought to be in the house. It is safest to have no plants at all in the house. For Peaches we should not like to use stable manure fresh until it had been thrown into a heap for eight days, and thus lost its rankest steam. For Vines with moderately-ripened wood such care even is not required. Litter and droppings may be brought at once from the stables, and, however rank the steam, it will do no harm to the Vines if not too near them, but will destroy every kind of insect, as the strong ammoniacal fumes will penetrate every hole and cranny, and the moisture will soften and swell the buds. In using sweet fermenting manure there will be no danger to anything that stands heat; hence a heap of tree leaves in a house is useful and safe. Turn them as you will, the steam from them will be sweet and safe. We have used stable dung fresh in a large house in such quantities that for a fortnight one could scarcely walk through the house, and the confined steam prevented one seeing far before him. No insect could live in such an atmosphere. The great thing with such mounds of dung was, by frequent turning, to get it perfectly sweet, though hot, before the buds swelled to breaking; after that, rank steam would be very injurious. The gases that escape from sweet decomposing manure are a great help to healthy, vigorous growth. Those from stable manure are more powerful than those from leaves, but a large heap of the latter and also of tan are harmless as to the gases they throw off. By forking over such heaps we have often filled a house with the richest steam when we wanted to do so. Forced to use every available place under glass almost constantly, we could not use fermenting material now, but none the less are we convinced of the importance of a hotbed in a house as a great help in early forcing.

ORNAMENTAL DEPARTMENT.

The Christmas Rose.—How interesting even among the snow does the *Helleborus niger* look, though anything but striking as a rough herbaceous plant when not in bloom. Even the *Helleborus foetidus*, with its fine foliage, would be no bad object in a sub-tropical garden. We are glad that *H. niger*, which yields its large flowers so early, is becoming more popular, as we may judge from the care taken of every lot by a neighbouring nurseryman in summer, so as to have good saleable plants before winter. There were several things that attracted our attention in the same nursery, such as the collections of fine old herbaceous plants and spring-flowering plants, telling us that the days are coming when we shall have mixed herbaceous borders again, and plenty of spring-flowering plants to fill our flower beds, with the addition of bulbs. Even as respects bulbs, we see proofs that ere long we may not be quite so dependent on our friends in the Low Countries, not, perhaps, so much in what our friend called his Californian gold field—a large space of Winter Aconite, from which numberless roots of

the largest sizes are taken every autumn, leaving enough to bloom thickly, and to seed and sow themselves from year to year; or in the large spaces of *Crocus*, and whole quarters of Snowdrops, grown for the general market; but in some parts water cannot be far from the surface, and we should not be surprised some day to see large quarters of the best Hyacinths, for the sale of the bulbs.

Having alluded to the general management of plants and houses lately, we may say now, that a little bottom heat from tree leaves will be a great help to Roses, Dantzas, Lilacs, Rhododendrons, *Spiræas*, double flowering Peaches, &c., placed in pits or houses. It is as well, if the roots are well established, to set the pot on the top of the bed for the first week or ten days, and then to plunge, or partly plunge, if the heat is mild. The varieties of the Chinese Azaleas answer admirably under such treatment, and will not need so much air as the above hardy subjects will require at first. All such plants, and even Camellias, will be better of a little manure water when swelling and opening their buds, and so will plants of *Salvia splendens*, where there is heat enough. One great advantage of this bright old plant is, that when taken to a coolish greenhouse until the flowers are nearly over, it will often, when deprived of the old flower stalks and slightly pruned, if taken back to a warmer place averaging 60°, bloom two or three times before getting exhausted. The late Chrysanthemums will also rejoice in manure waterings.

Such tender plants as *Eranthemum*, *Justicias*, *Goldfussias*, *Poinsettias*, and *Euphorbia jacquiniflora* are much benefited by manure waterings, clear and not too strong, whilst the bloom will be brighter in proportion to the light they receive. How pretty at this season is the old *Rivina humilis*, with its long racemes of bright red berries pointed with a few little white flowers! To have it nice and healthy all the winter and spring, there is no better plan than sowing every season in a hotbed in March, and growing the plants in rather small pots. There is generally some drawback as respects some of our greatest favourites. Thus, unless you have a very large plant it is next to impossible to have a fine compact bush of the *Poinsettia*. Small plants for little vases in heated rooms will always be rather long for their width. The *Poinsettia* can never be made to look compact so as to have a fine head of crimson floral leaves. You must have a tall strong shoot that will bear no stopping or pruning. Such a glorious crowned head, if the stem is cut carefully to a joint, will stand a good while in water or damp moss in a heated room, forming with a few Maiden-hair Ferns a fine feature in a vase of flowers. The rich crimson leaves when pulled off separately stand even longer, and form a rich dressing for the sides of small vases. When done flowering the *Poinsettia* may be kept drier and cooler, and the shoots may be cut down for propagating in spring, and as every bud will make a cutting, the shoot may thus be cut up into pieces from 2 to 12 inches long. To insure fine heads of floral leaves the plants can scarcely have too much heat, moisture, and light in summer; and comparative dryness, less heat, and full light in autumn, but not so much dryness as to cause a leaf to fall. When placed in more heat and moisture the flower and floral leaves soon appear.—R. F.

TRADE CATALOGUES RECEIVED.

Sutton & Sons, Reading.—*Sutton's Amateur's Guide and Spring Catalogue*.

Hooper & Co., Covent Garden Market, London, W.C.—*Seed Catalogue*.

TO CORRESPONDENTS.

N.B.—Many questions must remain unanswered until next week.

Books (*Treats*).—“The Cottage Gardeners' Dictionary” gives directions for Cacti culture. We know of no separate work on the subject (*J. E. M.*).—The “Gardeners' Almanack and Poultry-keepers' Calendar” has not been published since 1863. You can have a copy free by post of that, if you enclose thirteen postage stamps with your address.

LAWN SAND (*W. D. E.*).—We do not know it, and we cannot withdraw our opinion.

MANURING ROSES (*Rosery*).—Winter is not the best time for applying guano to Roses, though this manure is very valuable when Roses are in full foliage. We should advise the cesspool to be emptied about March into a heap of sod and ashes, and this applied as a top-dressing to the trees, forking it in among the roots. Let the guano be applied as a liquid manure while the Roses are forming their buds for blooming, or at any time during the summer when the weather is very dry. It is too stimulating and transient in its effects to use as a winter dressing. When the land is sandy, as in your case, a mulching, applied during the winter, of good stable manure, is of great value. It can be raked off in spring,

and what is left forked in, and a mulching of coco-nut fibre may be applied during the summer to protect the roots from the sun in hot dry weather.

RUSSIAN VIOLETS (*Sunny*).—All Violets are the better of a situation shaded from the midday sun. An east border is a good aspect. They flower from February to May, and in mild seasons they commence flowering early in winter, and continue in bloom throughout the winter and spring.

ROSES FOR COVERING IRON ARCHES (*Idem*).—There are climbers suitable for planting with Roses, and we should not employ Hybrid Perpetuals, but the climbing Roses, as—Alice Gray, Dundee Rambler, Ruga, and Splendens, of the *Ayrshire*; Adelaide d'Orleans, Myriamthes, and Rampante, of the *Evergreen*; Madame d'Arblay, and Rivers's Queen, of the Hybrid Climbing; Anadis, Gracilis, and the old Red Boursault. These, for the purpose you require, are very beautiful.

PAMPAS GRASS AND TRITOMA (*Idem*).—Cutting off the old or last summer's growth very much weakens the former plant, and in a cold situation the *Tritoma* as well, if the winter proves severe. We have known plants cut down killed, while those on which the old foliage was left until spring were not in the least injured. Protect them in severe weather with a little dry litter spread over them, removing it in mild periods.

LATE DUKE CHERRY (*A. McCallum*).—You must have the wrong variety, as the habit of the tree of Late Duke is not the same as that of the Morello. It is more like the May Duke in growth, and the fruit is excellent.

PEAR, CRAB, QUINCE, AND PARADISE STOCKS WORKING (*An Old Subscriber*).—The stocks planted last spring of the thickness of the little finger, will be fit for grafting next spring, but if of less size they would be best left till another year. It is well to have them strong before working. By all means graft those as thick as a man's thumb next spring. Whip-grafting is the best mode. The Manetti stocks should be budded next summer if as thick as the little finger. Bud quite close to the ground, or, indeed, below it, removing the soil about them for that purpose. Indeed, the bark does not part freely from the wood above ground. In planting them cover the junction with soil.

STOCKS FOR WALL, PEAR TREES (*E. M. J.*).—For Pear trees against walls we prefer the Pear stock, but it must be admitted that trees grafted on it do not come into bearing so soon as those on the Quince stock, which, however, ought not for horizontal training to be more than 15 feet apart on a 10-foot wall, and 12 feet apart on a 12-foot wall. We plant those on the Pear stock, and plant midway between each a double upright cord on the Quince. The cordons give us fruit before the others, and we cover the wall on a shorter year. Your climate must be bad indeed for Appricots not to succeed on a south wall. Plums we should prefer to Pears for a south wall; both do very well. Why remove the bloom buds? There will be few on the trees you get, or they will not grow much another year. For walls we like free-growing trees, not those stunted and pinched into early bearing. Your selection of Cherries is good. The fresh leaves will do for ground to be planted with Potatoes, if the ground is naturally rich, and with the guano you will no doubt have a good crop if the season be favourable. Three of the largest prize or Lancashire Gooseberries are—London, red; Leveller, yellow; and Antagonist, white.

ARRANGEMENT OF VINEY (*S. Castle*).—What you do with stages in your greenhouse is just extraordinary of what was referred to a few weeks ago, when speaking of using forcing houses for plant houses and wintering houses in winter. We like the whole so much, that if we made any alteration at all we would lessen the top platform and have more shelves at the back. Then, as that back pathway is 3 feet wide, instead of having one wide shelf over it, if holding numbers of small plants in winter were our object, we would have five or six shelves, say 9 inches wide, against the back wall, and would then borrow a lesson from Mr. Sheppard the nurseryman at Bedford, who uses movable brackets for shelf-supports, taking them out or merely turning them against the wall in summer, when tall plants may be set against the back wall.

VINEY—STOVE FOR PLANT CUTTINGS IN (*H. A. D.*).—For such a house as yours, if you did not mind the appearance, a small brick stove, either near the back wall or the middle of the front of the house, would on the whole be best; say a stove of brick-on-bed 28 inches square, 46 inches in height, a space left for an ashpit, and the firebricks fixed; above them a firebox made of firebricks, 8 inches square and 8 inches deep; close-fitting furnace and ashpit doors; the stove covered at top with a stout flag or a strong iron plate; a short outlet at the side, and a more upright pipe through the back wall or through the glass roof. On the top a vessel of water may be placed. Such a stove would give a more regular mild heat than iron; but with a little care a small iron stove costing from 4s. to 5s. would do for such a house. The chief point is to have a stove with the firebox lined with firebrick, so as to keep the burning fuel from the iron. We have seen a guinea stove that is frequently advertised, in which there is an iron firebox inside, leaving a space all round for heated air, and keeping the fuel from the sides of the stove. The outlet-pipe is at the top, and the top rounded, so that an evaporating basin cannot be used. These stoves are, therefore, better fitted for halls and corridors than for plant houses. We have seen far inferior stoves used safely in little plant houses; but on the whole, to obtain plenty of heat—safe heat—and moist enough if needed, it is best to use a stove with a flat top, and the opening for fuel on one side and the outlet for smoke on the other, and to have a firebox inside, so that the red hot fuel does not abut against the outside case of iron. It is also an advantage when the top can be taken off. We use a stove with a round movable top for lifting up and adding fuel, which with a little contrivance answers admirably; but when we want much heat we have to damp the floor all round it, as we cannot use an evaporating basin. We have an old square stove tied together with stout wires, and a flat movable top, with which we could do wonders. For all such stoves, when taking a horizontal pipe from the side, it should not exceed from 24 to 30 inches in length, coke and cinders are the best fuel, as coal soon clogs up the small pipe used for a chimney.

MANURING VINES (*M. E.*).—We are very sorry that the manure spread as advised at page 493 has injured your Ferns and Cinerarias, and we are rather surprised at it if you gave no more than 1 inch of dressing and left it on. This shows the importance of correspondents being particular, for of two things we were ignorant when giving the advice—first, that the poultry-yard manure was so fresh, and again, that you had Ferns, &c., in the house. If so, and using such dressing at all, we would

have advised doing it early in the day, covering with dry soil or charred refuse, giving more air, and leaving air on for a few nights. You have done the next best thing by covering with soil. We should think the Ferns will spring from the bottom all right, and all the better owing to removing the injured fronds; and so will the Cinerarias, but they will not be so good nor so early. No growing plant will withstand the fumes of ammonia from rank dung. The Pine Apples will endure them better than any plant we know.

VINE BORDER (A Constant Reader).—We should have preferred rather more drainage at the bottom of the border. We would not approve of one layer of fresh dark soil from a pasture and one equal layer of fresh rank manure from the stables. We should expect the border to sink very unevenly, and the Vines, if they succeeded well at first, would be apt to have their roots injured afterwards.

VINES (West Cumberland).—The Vines are not too old to remove to the front of your house, if you desire to do so. It is a pity to throw away such plants, but it is true that there is some difficulty in managing that variety. If you do want a change take either Madresfield Court, which is new, or the Royal Ascot, also new.

RATING NURSERYMEN'S GREENHOUSES, &c. (J. G.).—We reprint the following as you request.—We are of opinion that a nurseryman's greenhouses and his similar structures used exclusively in his trade are not rateable. A nurseryman rents a piece of ground, erects upon it greenhouses, and stocks it thoroughly. The parish then endeavours to rate him to the poor's-rate according to its improved value; and the question has arisen whether this higher rating is admissible. The question was brought before the Winchester bench of magistrates, and was decided by a majority that the higher rating is not maintainable. They held that greenhouses, unlike other buildings erected by tenants in other trades, do not attach to the land, but are always treated in law as stock in trade, which is clearly not rateable. What Lord Kenyon stated in *Penton v. Robert* (2 East 90), is so strongly in support of this view of the case, and is so illuminated by that enlightening policy which should influence a decision upon this question, that we offer no excuse for its quotation:—"The old cases on this subject," said his lordship, "I cannot consider as really (part of the modern) whatever was annexed to the freehold by the occupier; but in modern times the leasing has always been the other way, in favour of the tenant, in support of the interests of trade, which is become the pillar of the state. What tenant will lay out his money in costly improvements of the land, if he must leave everything behind him which can be said to be annexed to it? Shall it be said that the great gardeners and nurserymen in the neighbourhood of this metropolis, who expend thousands of pounds in the erection of greenhouses and hothouses, &c., are obliged to leave all these things behind them, when it is notorious that they are even permitted to remove trees, or such as are likely to become so, by the thousand, in the necessary course of their trade? If it were otherwise, the very object of their holding would be defeated. This is a description of property divided from the realty." Now, if a greenhouse be properly divided from the freehold, it cannot, in the case of a nurseryman, be anything but a part of his stock in trade, which, as we have already observed, is clearly not rateable. The bench were not unmindful of the recent decision in the *Queen v. Haslam* (Justice of the Peace, xv. 23); but they held, though not unanimously, that greenhouses being uniformly treated as part of a nurseryman's stock in trade, the present was distinguishable from that case. Since the foregoing was written there has been a decision of the highest court of appeal in Scotland, determining that a nurseryman's greenhouses and hothouses are removable by him, being only part of his stock in trade. Now the poor's-rate is only assessable upon the rent the land would let for, supposing all the stock in trade was removed. Such is our opinion; but you had better consult an attorney, and have your case tried before a barrister.

POISON IN EVERYTHING (Queen of Roses).—We believe the saying that "there is poison in everything" refers to the fact that everything may be eaten in quantities sufficient to injure health; and when Carrots are excepted, it is because no one could eat them in excess—they do not sufficiently tempt the appetite. If reference is made to the chemical composition of plants, the saying is strictly true, for all plants, Carrots not excepted, contain either sulphuric acid or chlorine, or both, each of which in its uncombined state is a poison. *Silphium erythraeum* has large yellow flowers, and is suitable for a shrubby, growing more than 3 feet high. *Cephalaria tatarica* is like a giant's Scabious, with light yellow flowers. There is a fine collection of flowers in the garden you allude to, but we never inquired anything relative to what you mention.

PLANTS FOR STOVE AND GREENHOUSE (Ignoramus).—*Stove Plants:* *Allamanda grandiflora*, A. Schott; *Alocasia metallica*, *Ardisia cuneata*, *Burchellia repens*, *Cissis discolor*, *Clerodendron Balfouri*, *Croton interruptum*, *C. variegatum longifolium*, *C. pictum*; *Cyrtocarpus reflexum*, *Dalechampia Roeziana rosea*, *Dieffenbachia Pearcei*, *D. Weirii*; *Dipladenia amabilis*, *D. crassinoda magnifica*; *Dracaena ferrea*, *D. stricta*; *Eranthemum pulchellum*, *Echegarhis amazonica*, *Euphorbia jacquiniiflora*, *Franciscia confertiflora variegata*, *F. eximia*; *Gardenia citriodora*, *G. dorida*, *G. radicans major*; *Gesnera exoniensis*, *G. refulgens*; *Hoya bella*, *H. carnosa variegata*; *Imantophyllum minutum*, *Impatiens Jerdonii*, *Xora acuminata*, *I. javanica superba*, *Jasminum gracile variegatum*, *Lasiandra macrantha*, *Maranta illustris*, *M. roseo-picta*; *Medinilla magnifica*, *Polystichia pulcherrima*, *Rogeria gratissima*, *Rondeletia speciosa major*, *Sanchezia nobilis variegata*, *Stephanotis floribunda*, and *Vinea alba*. In the above selection there are some variegated plants. *Greenhouse Plants:* *Aescia armata*, *A. longiflora magnifica*, *A. oleifolia elegans*; *Acrophyllum venosum*, *Aphelexis macrantha purpurea*, *Boronia Drummondii*, *Chorozema cordatum splendens*, *Citrus japonica*, *C. aurantium*, *C. nobilis*; *Cosyposma Baueriana variegata*, *Coronilla glauca variegata*, *Correa Brilliant*, *C. speciosa major*, *Cyclamen persicum vars.*, *Dracaena australis*, *Eriostemon intermedium*, *Erysa latifolia variegata*, *Eutaxia floribunda*, *Gentyllis fuchsoides*, *Hydrangea japonica variegata*, *Kalanthes coccinea superba*, *Lupageria roses*, *Lilium auratum*, *Myrtus communis*, *M. communis angustifolia*; *Nerium rubrum plenum*, *Pimelea decussata*, *P. Hendersonii*, *Polygala Dalmanisiana*, *Rhododendron jasminiflorum*, *R. Princess Royal*; *Rhynchospermum japonica*, *Statice profusa*, *Tremandra ericifolia*, *Vallota purpurea*, *Veronica Andersonii variegata*, *Camellia*—*Alba plena*, *Bealii*, *Fimbrata*, *La Pace*, *Madame Lebois*, *Mathotiana*, *Mrs. Cope*, *Napoleon III.*, *Rubens*, *Storyi*, *Valteverde*, and *Wilderi*. *Azaleas*—*Brilliant*, *Cheloni*, *Criterion*, *Duc de Nassau*, *Etoile de Gand*, *Extranei*, *Gledstanesi formosa*, *Mars*, *Queen Victoria*, *Stella*, *Vesuvius*, and *Wilhelm Lester*. *Epaerises*—*Hycinthiflora*, *Lady Pan-*

mere, *Viscountess Hill*, *The Bride*, *Alba odorata*, and *Eclipse*. Probably we have named too many, but when at the nursery you can select those you like best. For the greenhouse you will need *Primulas*, *Calceolarias*, and *Cinerarias*, but these you can raise from seed. We have not named *Gloxinias* and *Achimenes* for the stove. You will need some of each, and, no doubt, *Adiantums*.

GLAZING (S. M.).—If you make your grooves deep enough to give from one-eighth to one-fourth of an inch play for expansion at the sides, and with your incline you need not fear drooping, nor cracking if the glass is nicely cut.

MIXING LEAVES WITH FARM-YARD DUNG (J. T. S.).—One ton of farmyard dung mixed with an equal quantity of fresh leaves, if laid up until spring, and turned over twice or thrice, would make a good dressing for strawberries, and may be dug in now for crops of the Cabbage tribe. Of their value separately, there is no question that one ton of the farmyard manure is worth two of the leaves. Throw them up in a heap, sprinkling them with water if at all dry, and turn them over again in about ten days, watering well. They will need another turning in about three weeks, and in about three more they will be fit to put on the land. If you want the manure short, fully three months are required.

LAWN PATCHY (A Constant Reader).—Your best plan would now be to fill up to the level the holes scratched by the poultry, and let the lawn alone until the beginning of April; then rake it over, making sure that the surface is quite even, and sow some grass seeds over the bare places. If the weather is dry roll well, but if wet leave it, for if you roll whilst the lawn is wet the grass seeds would probably adhere to the roller, and so be moved from the bare places. If the whole lawn is thin of grass, in addition to sowing thickly over the bare places scatter a few seeds over the rest, say from 12 lbs. to 20 lbs. per acre, along with 8 lbs. of *Trifolium minus*.

HEATING WITH HOT WATER (J. Everaerts).—We think you make a mistake in dividing the yards by 20 instead of the cubic feet of the building, for then you will find that nearly three times the quantity of piping will be required. We can vouch for the rule being nearly correct as respects glass houses; but the less the cubic amount of air contained the more piping in proportion should be used. The large conservatory at Chatsworth is heated by dividing the cubic feet of air by 30, and allowing 1 foot of 4-inch pipe for every 3 cubic feet of air. For a lower house, dividing by 20 would be safer; 30 should be the divisor for lean-to houses where a medium of from 55° to 60° is required. When higher temperatures are wanted the divisor should be 25, and down to 18 and lower. Low span roofs would at least require one-third more piping. The rule is given for feet, not yards or inches.

PLANTS IN A ROOM (J. T. W.).—The Ferns will do tolerably well, and also the ornamental foliaged plants; but only near the windows will either long remain healthy.

PLANTING RED CURRANTS (J. F. C.).—We neither approve of Black, Red, nor White Currants being planted deeply so that their branches are layered, so to speak, in the ground. Larger fruit may be in some cases produced, but it is from the new wood that is sent up from the base, and these suckers soon become troublesome. We like every bush to have a clear stem, no suckers below the setting-on of the branches, and we invariably have fine fruit. We have no doubt that in light soils the planting so as to cover the lower parts of the branches is good, but they soon become little beyond suckers—stools, in fact.

HELIOTROPES (Idem).—There are no better dark Heliotropes for bedding purposes than the two you name. Monsieur Hamaire is a fine large purple, fine for winter flowering, and Surprise is a very fine dark sort. H. Voltairinum we suppose you have. It is a fine dark sort.

NAMES OF FERNS (Idem).—No. 1 is *Nephrolepis davallioides*. The atria roots extending over the pot are not a sign of its requiring potting, though when they are very abundant the plant must be growing freely, and would profit by a shift. We have had plants 12 feet across, and fronds over 6 feet in length. It was in an 18-inch pot, standing on sandstone rock, over which the aerial roots extended in all directions. Under good cultivation it makes a very handsome specimen. Pot it in rough brown peat, with plenty of sand and good drainage, and water freely. No. 2, *Gymnogramma tartarea*.

NAMES OF FRUIT (William Kemp).—*Pear*—2, *Beurré d'Arenberg Apples*.—1, *Wormsley Pippin*; 2, *Bradley's Nonpareil*; 4, *Dumelow's Seedling*; 5, *Winter Hawthornden*; 7, *Autumn Pearmain*; 8, *Wyken Pippin*; 13, *Norfolk Colburn*; 14, *Count-pendula-plot*; 15, *Kerry Pippin (Charlottenes Gildes)*.—A, not known; B, *Beurré Bachelier*; C, *Eldon Pippin*; D, *Beurré Six*; E, *Beurré Schidweiller*; F, *Vaner* of Wickfield; G, *Beurré Diel (E. W. Russell)*—*Passé Clair*. (Col. Harcourt).—*Glou Montan*.

NAMES OF PLANTS (J. Whittaker).—Your Orchid cannot be named unless we see one of its flowers.

POULTRY, BEE, AND PIGEON CHRONICLE.

AWARDS—TRIMMING.

I REGRET much that ill health prevented my replying to Mr. Hewitt's last letter the week after its appearance in these columns; and since then both myself and the Journal have been so much occupied with more pressing matters that I have not till now been able to do so.

What strikes me most throughout Mr. Hewitt's letter, perhaps, is the singular want of a looking at any of the questions spoken of in their real or general aspect, but instead thereof dealing with them as if they were entirely personal between him and myself—as if I individually were simply endeavouring to force more work upon him individually, which he in self-defence was bound to resist. Such was not my intention. I did not even wish or expect to extort from him a second reply

at all, as I can well imagine his extensive correspondence. I cannot accept his proposal to take his place and judge a show of five hundred pens, for reasons of which the following must suffice:—1, It is one of my peculiar opinions that no one possibly can judge five hundred pens as they ought to be judged. 2, There are breeds which I do not, and never pretended to, understand; and there are many who might, perhaps (I do not say they would), accept my judgment in regard to Brahmas, Cochins, and some other breeds, who would feel justly aggrieved were I called upon to pronounce upon their Hamburgs or Game fowls. 3, While Mr. Hewitt's time is his own, mine is not, and it is only on rare occasions that even my health would allow of my performing such an office. Mr. Hewitt cannot have known these things, or his appeal would bear an unworthy aspect of which I know him to be incapable; but he ought, perhaps, to have sought a little information on them before making it.

I can assure him the difficulties of a judge are no mere myths to me: I should get no new light on that subject, and all the rest would remain where it was. Whether a certain point raised by me is desirable or not to be adopted, is one general question which should be argued solely on its own merits. Whether, if adopted, it would further tax the judges; and if so, how overtaxing them can be avoided—that is another question. The one is certainly related to the other—that I admit; but it does not settle it; for the same argument would have prevented the dividing the sexes at Birmingham, the giving of four prizes (which Mr. Hewitt himself recommends) much less six, and many other desirable reforms which all demanded more time, but have been adopted nevertheless. How the increased labour may be lightened is a point on which I hope to say more at a future time.

Having thus disposed of one of his appeals to me, and of the time objection, only one argument is left. He says, if I "only want a close idea of the state of the competition," this is "fully met by a glance at the number of pens highly commended." That is very all I did want, or had in view; but his assertion a simple reference to a file of this Journal will show to be incorrect. I have repeatedly remarked reports of shows (sent by the judges themselves) stating that classes were of unusual or even "extraordinary" merit throughout, yet with only one or two commendations; while, on the other hand, instances occur where the distinctions are thick, yet the class is pronounced poor! The reason seems to me to be, that merely "highly commended" is too indefinite, and may mean almost anything; hence—and for no other reasons—I proposed some higher award to have some definite value. The diploma I mentioned in my second letter was not meant as a "new" proposal, and Mr. Hewitt should not have so stated it. In fact, the name is of little moment; and to show that nearly everyone but Mr. Hewitt seems to have understood me, and that my suggestion did receive some little "favour at the hands of committee," I received almost by next post several letters of high approval, two of them from secretaries of shows, one of whom suggested medals as better still. Since then I have had a schedule sent me, in which the 1st prize is an embossed card. I want something higher and more definite than mere "highly commended," that is all. What it is, so it fulfil these conditions, I care little; and why, after I had for the present given up the point of order of merit expressly on account of his protest, Mr. Hewitt should apparently fasten on this very acquiescence as a fault on my part, and accuse me of changing my "ground," I cannot quite understand. I can only say, now that several weeks have passed, many letters of approval I have received confirm my opinion that some intermediate award—whatever it be called—is greatly needed, and already the prize lists in the Journal show that one judge (at Newport) has adopted it.

On the trimming matter my remarks will be very brief. I have been shown, years ago, Bantam tails put in as cleverly as any seen now, but they were not found out. Men were quite as clever then as now, but only the ruder cases seem to have been detected. I must add, however, that much of what I wrote on trimming was directed more against shameless plucking—whether of hocks, hackles, body feathers, or tails—which judges can detect and punish if they choose, than against the rarer cases of deeper art. Cases almost impossible of detection, it is no discredit to the judges seldom to detect; but since Mr. Hewitt so personally challenges me and my opinions, I say deliberately and emphatically, that in my opinion the judges should not have given prizes to birds like many of the Cochins cocks at Birmingham, with the whole of the tails notoriously and shamelessly torn away. There was

no concealment there. This, therefore, is a barefaced fraud, for the toleration of which there is no excuse; and when I hinted at certain "results" of my labour, I had chiefly in mind the notorious fact that plucked hocks used also to win prizes with impunity, but very rarely do so now. I am confident I shall see the time yet when plucked tails will share the same fate. I was very glad to see Mr. Hewitt this season join in giving prizes to decidedly hooked birds of merit when honestly shown; and he must allow me to believe that this and other objects I have at heart are more likely to be realised by my working in my own way than in that he suggests for me.

I quite admit the want of time to detect many of the "finer branches" of trimming. My original proposal was, therefore, that any such discoveries after judging should still disqualify. I yet believe this to be the only remedy.

I have only to say in conclusion, that regarding the "protestor" who was disqualified, I did not say it was an injustice to "refer to such an enormity." The injustice I feared had been done, was in a mistake as to the fact, not in referring to the matter. In asking for the names, I had no thought of requesting their publication, but only that they might be given me; but on reading over my own letter, I am bound to admit that the language of the request will fairly bear the construction Mr. Hewitt put upon it, and I cannot, therefore, complain.

The remaining portion of his letter, on buying prize pens, relates to a question not raised by me, and with which I have nothing to do. I hope shortly, however, to say a few words upon difficulties and mistakes in judging, and their remedies. On these matters I trust Mr. Hewitt and myself may find more agreement, and I quite coincide with him in the opinion, that on behalf of the judges also, who so kindly give their aid to the fancy, mostly without charge, and too often without even thanks, much, very much, indeed, needs alteration for the better in the arrangement of our shows.—L. WRIGHT.

OILING THE PLUMAGE OF EXHIBITED BIRDS.

WHEN people be never content to exhibit their birds fairly without in some way or other tampering with their plumage? In some cases out of ten the dishonesty is at once detected, but supposing it to be overlooked, and a prize gained, what a paltry recompense when honour is endangered! One of the latest "tips" in plumage-doctoring is to oil birds' hackles with intent to make them appear darker than they actually are. The case in point occurred not long ago at one of our leading shows. A pair of Brahma pullets were noticeable for their dark hackles, so much so that one of the judges on meeting the owner asked what had been done to them. The reply was that they had been oiled. Now, I will not mention our friend's name, as I fear I should damage his reputation by so doing, and I merely wish to give him a timely warning, which I hope he will take in good part, to avoid such trickery for the future. If "Nemo" had the handling of him I could not be answerable for the consequences.—NEMESIS.

WHITE BANTAM CLASS AT MANCHESTER SHOW.

HAVING no more subscriptions to record, I beg to say that the prizes in the above class will be—1st, £2; 2nd, £1; 3rd, 10s. Subscribers' names have already appeared in this Journal. This sum is the amount of subscriptions received.—SAML. J. ASHTON.

RAILWAY NEGLECTS.

I HAD been anxiously looking forward for the last three months to the Crystal Palace Poultry Show, and at the proper time I sent ten entries for Dragons, for which I paid £2 15s. The birds left here (Birkehead), by the 11.40 train on the Monday morning previous to the Show, and should have been delivered the same evening. Almost every bird I sent had won prizes at some of the principal shows, and I consequently believed my chance to be second to none for at least one of the cups; judge of my surprise on receiving a list of awards, not to find my name even among the commendeds. On Thursday I accidentally heard my birds did not arrive until too late for the judging, which took place late on Tuesday; in fact, they did not arrive until Wednesday. I do think the Secretary of the Show is to blame in not writing me when he found they had not arrived, even on the Tuesday, so as to allow me to make some inquiries as to their whereabouts. I suppose if

they had never reached their destination I should have been left in ignorance. I have good proof that if they had been there in time I should have won one if not both of the cups offered for Dragoons. Have any of your readers been in the same fix, and did they obtain any redress from the railway company? I shall be very glad of any experience on the subject, as I intend suing the railway company for my loss.—FRANK GRAHAM.

CRYSTAL PALACE POULTRY SHOW.

THE birds were carefully tended, but I must express my own opinion—not a solitary opinion—I am very certain that pens with wire backs and fronts are an abomination. It was almost impossible to make any bird face you, and thus, judging must have been more difficult; or if the birds did face, they backed against the wires to the great damage of their tails. Most of the pens, however, had another serious fault; for the large breeds they were neither high enough nor large enough. Many a Dorking cock looked as if he had a wry tail, simply because he had no room to carry it properly. So, again, one or two of the Malay cockerels did not show themselves off from want of height in the pen. I believe the pens used were those of Mr. Billett, and have been lauded in "our Journal," but for many breeds they are decidedly too small. I heard much grumbling, and some talk of a protest being set on foot; however, I trust that there will be no occasion for such a course.

My chief object in noticing the Exhibition is to give a little analysis of the entries, which may prove useful to schedule-framers and committees. I have often before in our pages urged the desirability of making classes for all breeds at all established shows; they may not always fill, but they always add an attraction to visitors, and make a variety.

In the following table I have endeavoured to show the number of entries in each class, the amount of prize money offered, adding to each class a share of the silver cup offered between them, and in the last column the amount that the entries produced. I put them in two divisions, in the order of the catalogue, the first division being those that repaid the exchequer by entries, the second those that failed to do so.

FIRST DIVISION.

	Entries.	Prizes offered		Amount entries produced.	
		£	s. d.	£	s. d.
1. Coloured Dorking	74	16	10 0	27	15 0
2. Dark Brahma	75	17	5 0	28	2 6
3. Light Brahma	91	21	15 0	33	15 0
4. Houdans	59	19	5 0	14	2 6
5. Other French varieties	29	8	0 0	10	17 6
6. Gold-spangled Hamburg	20	6	1 0	7	10 0
7. Gold-pencilled Hamburg	21	6	1 0	7	17 6
8. Silver-spangled Hamburg	22	6	1 0	8	5 0
9. Black Red Game	47	19	15 0	17	12 6
10. Golden Polands	15	3	10 0	5	12 6
11. Silver Polands	12	3	10 0	4	10 0

SECOND DIVISION.

1. Silver-Gray Dorking	40	13	11 0	15	0 0
2. White Dorking	14	6	11 0	5	5 0
3. Buff Cochins	27	16	15 0	10	2 6
4. Partridge Cochins	24	16	15 0	10	10 0
5. White Cochins	15	6	5 0	5	13 6
6. Spanish	70	33	12 0	26	5 0
7. Silver-pencilled Hamburg	14	6	1 0	5	5 0
8. Black Hamburg	15	6	1 0	5	12 6
9. Brown Red Game	19	10	15 0	7	2 6
10. Duckwing Game	25	14	15 0	9	7 6
11. White-crested Black Polands	6	3	10 0	2	5 0
12. Malay	9	3	10 0	3	7 6

Now, can we gather anything for future arrangements from the experience of the great London show? Clearly the first division deserve every encouragement, not because they are more useful, not because they are more beautiful, not because they are the hardest, but in the eyes of Committees, simply because they return their prize money. Is this the end, the one object of our poultry exhibitions, many of which are said to be formed for the encouragement of the breeding and improvement of domestic poultry? Or rather should not the prize money be so meted out as to encourage as much as possible all the established breeds, that either for hardness, beauty, use, or special peculiarity, have more or less their admirers? I submit the latter is the right course.

The eccentricities of entries are marvellous. Why Buff Cochins should turn out in such miserable numbers at the Crystal Palace, nobody knows or will know. Why Brown Red Game should be eclipsed in numbers by the Duckwing tribe is

another mystery. Why Golden Polands, that a year or two ago appeared "polled out," should come with a rush and distance the Silvers, is inexplicable. All this only proves that in the outset of framing a schedule no Committee, however shrewd, can declare which breed will enter best.

We have two other really grand shows coming off; we have Bristol and Clifton, with no Malay class, and Polands all lumped together. This, I contend, at such a show is most unfair, and I trust it will be the last time such a course will be pursued. Manchester is as bad in this respect, and is very peculiar in one or two other points. What has happened to the prizes for Hamburgs? the division is most strange. No Malay class, and Polands all lumped together! I am far from desiring that every little exhibition should sub-divide its classes to a great extent, but I do contend that at grand shows, where a large collection of poultry may be expected, the breeds I have mentioned should be offered a separate class. The experience of the great London show abundantly proves that they will enter fairly.

One word more. I venture to say that for the shows themselves the division of sexes is a mistake, at any rate for the less popular classes, and that for practical purposes the cock and one hen will avoid the difficulties of matching, and give a greater probability of entries, while causing a far smaller drain on the exchequer.—Y. B. A. Z.

THE USE OF STICKS AND UMBRELLAS AT POULTRY SHOWS.

At the late Birmingham Show I exhibited four pens of birds, and although they were not considered worthy of a place in the prize list, they were of sufficient merit to have taken prizes at several shows. On Monday, November 28th, I saw them and they were all right; on Wednesday I again visited the Show, and was informed by a friend that one of my pullets could not stand, and that my man had unsuccessfully endeavoured to raise it. I immediately drew the attention of the attendants to it, who did all they could, allowing me to send it home, where it now is much in the same condition. I have little doubt as to the cause, which would suggest itself to anyone who saw, as I did, persons poking and stirring-up birds with a stick with iron on the end. I believe, in the case of my bird, a probe on the hip-joint is the cause of the lameness. I am not alone, for one of our largest exhibitors and most frequent prizetakers, has now a bird—a cock, with his comb injured by a stab, whether wilfully done or otherwise, I cannot say. At nearly all exhibitions the public are prohibited taking sticks, umbrellas, &c., why not at poultry shows? I contend that the value and comfort of the birds ought to be taken into consideration, rather than the gratification of spectators, many of whom may ignorantly injure a bird, while others with a better knowledge, but a worse spirit, may take the opportunity of removing from the field of exhibition a bird which has been, and would be, a successful competitor.—J. H.

WEST OF ENGLAND POULTRY SHOW.

(From a Correspondent.)

THIS Show, held at Plymouth on the 13th, 14th, and 15th inst., exceeded by far any of its predecessors both in numbers and quality, and it may be perhaps considered the best exhibition seen so far west for many years.

GAME, Black-breasted and other Reds.—First-prize a cock of beautiful colour, hen not so good; second-prize cock hardly large enough, but otherwise a most perfect bird—indeed, the Judge considered these pens equal to anything shown at Birmingham. A very fair pen of Brown Reds was shown in this class by mistake, otherwise it would have been third. The remaining birds were fair average specimens.

In the *Any other Variety* class the first three pens were of good colour, and shown in perfect condition; the rest were not so creditable. The first prize birds were certainly out of condition.

Of Single Cocks the first-prize was a clean, tight, handsome bird, shown marvellously well. Pen 52, shown by the same exhibitor, would have stood higher had he not been too much spoiled by fighting.

In *Indian Game* the first and second-prize pens were creditable, although the whole class exhibited strong traces of the Malay.

DORKINGS.—This class was first-rate throughout. The first-prize winners were good in frame and feet; the second not so good as regards the cock; the third hardly so good as pen 94 (very highly commended). The cock's comb had an excrescence on either side. All the noticed pens were bad in the feet.

COCHINS.—Buffs.—In this class the birds were badly matched throughout, and in all cases the cocks were inferior to the hens, which

were as much superior as the former were weedy. The first-prize pen contained a grand hen of capital colour; the cockerel mated with her was perfect in this respect, but far too small. The second-prize birds were out of place and not so good as the third, which were large and heavily feathered, but more neatly in colour.

Partridge.—A very good class. The first, second, and cup birds were remarkably good. First a good bird, well-shaped, good in colour and feather; hen first-class. The second-prize cock was of fine shape and superior to the first-prize one, but mated with a weedy pullet not at all worthy of a place in the prize list. Third-prize birds large in frame, but slightly red in the thigh and badly shaped in the back. Pen 121, winner of last year's cup, displayed too much white in the tail to place him again in the prize list. The cocks were superior to the hens throughout the class.

White.—A remarkable class and badly judged. Excepting a pen of very filthy chickens the whole of the birds were of excellent quality. First, a very white cock of very fair shape, but too large in comb and too full in tail; the hen, although good, was far inferior—indeed, the pair weighed fully 6 lbs. less than three or four other pens. Second, a somewhat similar pen to the first, clean and white, but neither so large in frame nor the cock so well feathered. The third-prize pen contained a grand hen, white as snow and nearly perfect; cock a very fair bird. Pen 127 (highly commended), contained a superb hen, large, clean, and well-feathered, but mated to an inferior cock. Either of these pens was superior to the winning birds, as also was an unnoticed pen, 132, containing by far the grandest-shaped cock in the class, with a perfect comb, tail, and hook; the hen with him was also a high-class bird. It was very noticeable in this class, also in Light Brahmas, that every pen was passed over by the Judge where the plumage was at all soiled, entirely disregarding the merits of the birds; although some were "dirty" throughout the two classes, and in spite of the awards, we have yet to learn that a pen to win must be so miraculously clean.

Brahmas.—*Light.*—A really capital class, and the best ever seen in Plymouth. The cup pen was most decidedly a mistake, the pullet being small and unworthy of her position. The cockerel was, however, a good bird, grand in carriage and colour, but too arched in the neck, well pencilled, and certainly small. Second a heavy bird, poor in tail and pencilling, with only a moderate hen. The third-prize pen contained the best hen in the class, large, heavily feathered, and prettily pencilled. The cock was, however, far too poor; indeed, there were two or three pens decidedly superior in points to those which had the second and third prizes. An unnoticed pen (No. 139), brother and sister of the cup-winners, if judged by points alone, should have stood first, both being larger birds; the cockerel, perhaps, not so good in carriage, but equal in every other respect. These cockerels far surpassed everything else in the class, and will be heard of again, almost equalling any other birds of the year.

Dark.—Thirty pens competed in this class. The first-prize pen was well judged, both birds good in colour, grand in shape and size, and were soon claimed at £6. The second-prize pen was also good, but by no means equal to the winners in colour or size. Vulture-hooked birds were numerous, including the third-prize cock, which we think a mistake; Mr. Beachy's commended pen, also No. 164 (highly commended), being preferable.

Polands.—This was a very poor class both in number and quality. Mr. Pickles was first with a pen of Silvers, much overshown and scarcely able to stand in the pen. Second, fair Golden; third, White-crested, and the most deserving pen in the class. With the exception of an unnoticed pen of Silvers, the remainder were poor.

Spanish.—A poor class throughout. With the exception of the first-prize cock there was not a first-class bird; he, however, was really a high-class bird, and, mated with a better hen, would have taken the Society's cup. Second and third only fair pens, but they will show better before long.

Hamburgs.—*Golden-pencilled.*—Mr. Barter was first and second with first-rate pens, good in comb, tail, and earlobe, and of capital colour; in fact it was difficult to choose between them. Mr. Pickles was third with a moderate pen much overshown. The remainder were nowhere, the combs being particularly noticeable from their inordinate size. This was a large class.

Silver-pencilled.—Mr. Pickles was first with a fine pen perfect in all points. The second-prize pen was only inferior in colour, running the winners very closely; the third was also a good pen. The others were decidedly poor.

Golden-spangled.—The winning pens were such as are seldom seen in the West. The first were simply perfect; the second and third little inferior. The remaining pens were all poor, the majority being much overgrown in the comb.

Silver-spangled.—This was a wonderful class, both in numbers and quality, and nothing like it has ever been seen west of Bristol. Mr. Barter's first-prize pen took both the Hamburg and Society's cups. They were almost perfect. The second-prize pen was first-rate, but the hen's comb was slightly hollow, and she was a little too heavily spangled. The third and all the noticed pens decidedly good. Mr. Pickles's pen would certainly have been in the prize list but for the white face of the hen.

Bantams.—*Game.*—This was a large and good class. The first-prize cock was a little beauty, but slightly striped in the hackle, and the pullet too mealy on the wing, otherwise the birds were first-rate.

The second-prize birds were a very fair pen, but larger than the first. Third, Duckwings, good in colour, and thoroughly Game. By far the best pen in the class, No. 285, was unnoticed, the pullet showing stumps of feathers down the legs; the cockerel was almost matchless, and such as is very rarely met with; in every other respect the pullet was fully his equal. This cockerel will, doubtless, be heard of again.

Any other variety.—This was a poor class, and without one thoroughly good pen. The first and third-prize pens were moderate Black; the second fair Golden Sebrights. A pen of Silkies was fully equal to either of the winners, also a pen of Laplands, the cock, however, was deficient in crest.

ANY OTHER VARIETY.—A very good class. Houdans were first; the hen very old, but a capital bird in every respect. The cock was too dark and short in one wattle. Second, a fine pen of Crève-Cœurs, good in crest and colour. Third only moderate Black Hamburgs. Miss Williams's pen of Crève-Cœurs, which we think could not have been seen by the Judge in consequence of their removal to a larger pen, were the best in the class.

THE SELLING CLASS mustered forty-five pens, and contained some very cheap birds. A pen of very fair Dorkings was first; Light Brahmas second, the cockerel a grand bird, but light in neck; third, a nice pen of Game.

THE DUCKS, GESE, AND TURKEYS were not first-rate. First-prize Aylesburys were heavy, but dirty, bad in bill and feather, and very clumsy. Second not so heavy, but otherwise very good, and an easy first in all but weight.

PIGEONS.—The first-prize *Carriers* were bad in eye and wattle, and although claimed at a high price, we think a mistake. Mr. Yardley's commended pen was very poor, coarse in wattle, and poor in eye. *Tumblers* and *Fantails* were very good, and well judged, both first-prize pens being excellent. *Barbs* and *Nuns* were good in the prize birds. *Jacobins* were not first-rate. *Pouters* were simply a farce, there not being a real Pointer in the Show.

The chief blot of the Show was owing to the pen-contractor, many of the pens being only of the proper size for a pair of Pigeons. In the Any variety class many birds could not stand upright, and the beautiful pair of Houdans which took the first prize literally could not move, and must have suffered horribly.

There were many single birds in all the classes of very great merit, but too often badly matched. In several cases exhibitors of the large breeds showed birds which, if the best had been put together, would have commanded the first prize.

GAME.—*Black-breasted and other Red.*—1, C. H. Martin, 2, N. Barter, Plym. 3, E. A. Adcock, 4, J. Doney, 5, R. Hickam, *Indians*—1 and 2, Mrs J. J. Richards, 3, Bow, 4, J. Palmer, 5, J. Bower, J. Jasper. *Any other Variety.*—1, E. Martin, St. Austell, 2, J. H. Reynolds, Truro, 3, E. C. Pope, Falmouth, 4, R. Dawe, T. Hawken, J. Hoyt, F. Westlake, 5, E. S. Higham. *Cock.*—1, J. Harris, Liskeard, 2, E. C. Pope, 3, Dr. Bullock, Falmouth, 4, E. C. Pope, 5, R. S. Higham.

DORKINGS.—1, E. Burton, Truro, 2, R. W. Beachy, Torquay, 3, W. Brown, 4, Mrs. Wolcombe, Stowford Rectory, 5, Mrs. Thynne, J. Ward, W. Trevithick, E. Barton, 6, W. Brown.

BRAHMAS.—*But or Cinnamon.*—1, S. R. Harris, St. Day, 2, Mrs. Wolcombe, 3, W. Masland, Milverton, 4, he, and 5, Mrs. Wolcombe, 6, G. Widger, J. Midway, T. M. Hawke. *Partridge.*—1, Cup and 2, J. Beard, St. Blazey, 3, J. Long, Plymouth, 4, J. H. Nicholls, 5, W. Beckerley, E. Cornelius. *White.*—1, F. Rogers, Bristol, 2, T. M. Hawke, 3 and 4, F. Brewer, Lostwithiel.

BRAHMAS.—*Light.*—1 and Cup, H. T. Pearce, Tonnass, 2, P. D. Maddox, Launceston, 3, J. H. Nicholls, Lostwithiel, 4, Mrs. Wolcombe, 5, Mrs. Wolcombe, Rev. J. Bailey, 6, W. Masland. *Dark.*—1, R. W. Beachy, 2, J. G. Price, 3, J. H. Read, 4, E. Burton; F. Seccombe, 5, H. Eurt; E. Cornelius; Mrs. Thynne; F. Seccombe.

POLANDS.—1, H. Fickles jun., Farby, 2 and 3, T. Jacobs, 3, J. Beard.

SPANISH.—1, G. Toukam, Bristol, 2, J. H. Read, Colstock, 3, J. Gildion, Bristol, 4, J. H. Nicholls.

HAMBURGS.—*Gold-pencilled.*—1 and 2, N. Barter, 3, H. J. Fickles, *Silver-pencilled.*—1, H. Fickles jun., 2, 3 and 4, N. Barter, *Gold-spangled.*—1 and 3, J. Midway, Newton Abbott, 2, N. Barter, *Silver-spangled.*—1, Cup and Society's cup, N. Barter, 2, Miss E. Browne, Chard, 3, E. Newton, 4, S. Newick; J. Woodley; S. R. Harris; Miss E. Browne, 5, S. R. Harris.

BANTAMS.—*Game.*—1, N. Barter, 2, J. H. Glossop, Weston-super-Mare, 3, J. Pearson, 4, T. Jacobs, Newton Abbott, 5, E. Burton; J. Callacott, Tavistock.

ANY OTHER VARIETY.—1, F. Brewer, 2, N. Barter, 3, C. Drake, Ipswich, Lostwithiel, 4, E. Burton (Minceas); J. Long, 5, P. D. Maddox (Houdans).

SELLING CLASS.—1, F. Seccombe, 2, H. D. Pearce, 3, S. N. Davey, 4, P. D. Maddox; W. Humphreys, Liskeard.

DUCKS.—1, J. H. Nicholls, 2, T. E. Hawken, *Rouen.*—1 and 2, J. H. Hoyt, 3 and 4, E. Burton, *White Aylesbury.*—1, S. R. Harris, 2, T. E. Hawken, 3, S. R. Higham, 4, F. Brewer; F. Seccombe; B. Slaughter.

GESE.—1 and 2, F. C. Ford, Plymouth.

TURKEYS.—1 and 2, J. B. Parsons, Launceston.

PIGEONS.—**CARRIERS.**—1, J. H. Glossop, 2, W. H. Mitchell.

TUMBLERS.—1, T. Chudley, 2, E. Barton.

FANTAILS.—1, H. Yardley, 2, S. Richards.

ANY OTHER VARIETY.—1, H. Yardley, 2, F. Brewer.

Mr. Fielding judged the *Game, Hamburgs, Bantams, and Ducks*; Mr. L. Wright the *Dorkings, Cochins, Brahmas, Polish, Spanish, and Any other variety*; and both the Judges together the *Selling Class*.

REIGATE POULTRY SHOW.

This was held on the 13th inst., when the following awards were made:—

LOCAL CLASSES.

DORKINGS.—1, Ivory & Son, Dorking, 2 and 3, E. T. Bennett, Betchworth. *Chickens.*—Special for best pen of Dorkings in the show, 1 and 3, Ivory & Son, 2, G. Ellis, 4, E. T. Bennett, 5, G. Allen, Euckland; J. W. Taylor. *White.*—1 and 2, Mrs. Jaffray, Betchworth, 3, J. Clutton. *Chickens.*—1 and 2, Mrs Jaffray, 4 and 5, P. Hanbury, Redhill.

SPANISH.—1, 2, and *hc*, Francis May, Reigate. *c*, E. Ritherden, Reigate. *Game*.—1, W. Oakley, Oxford. 2 and *hc*, P. Hanbury. *Chickens*.—1 and Cup for best pen of Game in the Show, and 2, J. Mew, Reigate. *hc*, W. Oakley; J. Clifton; J. Mew.
BANTAMS.—*Game*.—1, H. J. Jones. 2, P. Hanbury. *hc*, H. Simmonds; J. Mew; Mew, Brothers. *c*, W. Oakley. *Any other variety*.—1, P. Hanbury.
COCHINS.—1, A. O. Wilkinson. *hc*, P. Hanbury; A. O. Wilkinson.
TURKEYS.—1, W. C. Gyles, Reigate. 2, J. W. E. Matthews, Chipstead.
POULDS.—1, Sir H. A. Glass, Ashurst. 2, G. Simpson. *hc*, W. Oakley.
GEES.—1, W. J. Taylor. *hc*, J. Selmes. *Goslings*.—1, W. Heusman, Oxford. *hc*, H. Wise, Brockham.
DUCKS.—*Any*.—1, W. Oakley. *Ducklings*.—1, Mrs. Jaffray. *hc*, Mrs. Jaffray; G. Allen. *Toucan*.—1, G. Simpson. *hc*, Ivery & Son. *Ducklings*.—1, Ivery & Son. *hc*, W. Oakley. *Any other variety*.—1, T. Hanbury. *Ducklings*.—1, J. Clifton. *hc*, P. Hanbury.

JUDGES—Mr. Headley and Mr. Wood.

LEEDS POULTRY SHOW.

UNDER the management of Mr. Swales, who is one of the most obliging of honorary secretaries, and a very attentive committee of management, the Leeds Show annually becomes more and more popular; the collection of poultry, Pigeons, and Rabbits shown on the 13th, 14th, and 15th inst., being a great improvement over those of years gone by. The attention paid to the comforts and necessities of the birds exhibited was all that could be desired.

Very rarely have such good classes of *Game* fowls been brought together at any show, the only drawback being the great difficulty experienced by the Judges in taking out any of the birds for the purpose of close examination, as the front wirework ran the whole length of the row of pens. The silver cup for Game fowls was taken by an excellent and well-shown pen of adult Duckings. A considerable proportion of the *Dorkings* were evidently much the worse from being too frequently exhibited; a few pens that were decidedly "ronny" appeared in this division of the Show. One of the most perfect varieties of poultry shown were the *Spanish*; in fact, there was scarcely a pen of anything like inferior quality in the whole lot. This season's birds proved to be the winners of the cup. Some extraordinarily good *Cochin* and *Brahma* fowls were shown, but not in the condition for exhibition that might at this season be reasonably expected. In Class 42. Any variety of *Cochin* chickens, pens 422 and 423, being the first and second-prize pens, were so evenly balanced as to quality that the Judges were long in bringing their award to a conclusion. It was the closest run seen for many years. The *Hamburgs* fully supported the high repute of the district, and the classes throughout were unexceptionably good; a remarkably fine pen of Golden-spangled chickens took the cup. The *Polish* was all shown together, and such a display is but rarely to be seen anywhere. Blacks with white crests took the first prize, and the Golden and Silver-feathered were scarcely less worthy of note. In the "Variety class," *Crève-Coeurs* and *Hondans* divided the prizes between them. Among the *Game Bantams*, a pen of perfect Brown Reds took the cup, being more correct in feather than any that have yet been exhibited. The *Waterfowl* and *Turkeys* were a first-rate collection, Mr. Burn's pen of *Buenos Ayrean Ducks* that took precedence, being in such show-trim as is rarely equalled.

The *Pigeons* were better than have ever before been seen at the Leeds Show, but were placed far too high for general inspection, this tier being raised some 8 or 9 feet from the ground, so that ladies, particularly, could scarcely get a glimpse of them. As this portion of a show is usually one of the most interesting to visitors, an alteration in the arrangement in future years would be most advisable. Carriers took the silver cup for the best pen of Pigeons exhibited.

At least equal to that of any former year, if not in excess, was the attendance on the first day of opening to the public, and on the following, we are informed, so well filled was the Show that it was difficult to move about.

GAME.—*Black-breasted Red*.—1, J. Laming, Spalding, Lincolnshire. 2, H. M. Julian, Hull. 3, J. Firth, Chatsworth, Bakewell. *hc*, C. W. Brierley, Middleton, Manchester; W. Harker, Cottingham, Wngley. *c*, J. Superland, Halifax. *Chickens*.—1, C. W. Brierley. 2, H. M. Julian. 3, J. Harker, Alerton, Bradford. *hc*, Barker & Charnock, Ilmington, Halifax; G. Ducker, Leeds; J. Hodson, Bradford; J. Barrow, jun., Kendal; T. Blackburn, jun., Northalton. *Brown-breasted and other Reds*, except *Black-breasted*.—1, C. W. Brierley. 2, A. Haslam, Headley, Wigan. 3, E. Aykroyd, Eccleshill. *hc*, J. Laming; F. Sales; W. Johnson, Idle, Leeds; J. Barrow, jun.; J. W. Thompson, Southwray, Halifax. *Chickens*.—1, J. Firth, Chatsworth, Derbyshire. 2, T. Bottomley, Shelf, Halifax. 3, C. W. Brierley, Middleton. *hc*, J. Wilkinson, Farby, Skipton. *Duck-wings*.—1 and Cup, H. Jowett. 2, J. Firth. 3, H. M. Julian. *hc*, F. Sales; W. W. Robertson, Halifax. *Chickens*.—1, H. C. & W. J. Mason, Drighlington. 2, J. Firth. 3, W. J. Cope, Barnsley. *hc*, H. M. Julian; M. Jowett; E. Winwood, Worcester. *c*, J. Wilson, Ilmington Moor, Halifax. *Any other Variety*.—1, E. Aykroyd. 2, J. Sables, Great Urthwaite. 3, F. Sales. *hc*, H. C. & W. J. Mason; Duke of Sutherland, Trenham Hall, Stoke-on-Trent; R. Butcher, *Chickens*.—1, E. Aykroyd. 2, C. W. Brierley. 3, R. & M. Walker, Woodwood, Gomersal. *hc*, E. Winwood. *Cocks*.—1, T. Mason, Green Ayre, Lancaster. 2, R. Butcher, Cresswell, Chesterfield. 3, F. Sales, Crowle, Doncaster. *hc*, H. M. Julian; W. Spencer, Haworth (2); J. Laming; J. Firth; C. W. Brierley. *c*, E. Bronagh, Leek.

DONKEYS.—1 and Cup, L. Patton, Hillmore, Tannock, Somerset. 2, C. W. Brierley. 3, H. Ebdon, Gortstock, Bingley. *Chickens*.—1, W. H. King, Sandfield, Rochdale. 2, Rev. G. Bunsler, Stillingfleet, York. 3, J. White, Wariaby, Northallerton.

SPANISH.—1, Hon. Miss D. Pennant, Penrhyn Castle, Bangor. 2, W. Pickard, Thorne, Leeds. 3, H. Beldon. *c*, J. Thresh, Bradford; W. Schofield, Gildersome. *Chickens*.—1 and Cup, C. W. Brierley. 2, J. Thresh. 3, J. Booth, Sliden, Leeds. *hc*, H. Beldon; H. Wilkinson; J. Walker, Wolverhampton. *c*, S. Powell, Bradford; Hon. Miss D. Pennant.
COCHINS.—1, W. C. Gyles, Reigate. 2, and Cup, W. A. Taylor, Manchester. 3, T. Stretch, Ormskirk. *hc*, J. Cattell, Birmingham; R. White, Shirebrook, Sheffield. *Chickens*.—1, T. Stretch. 2, C. Sidgwick, Kiddleston Hall, Keighley. 3 and *hc*, W. A. Taylor. *Any other Variety*.—1, T. Stretch. 2, W. A. Taylor. 3, C. Sidgwick. *Chickens*.—1, C. Sidgwick. 2, E. Leech, Rochdale. 3, W. A. Taylor. *hc*, Rev. R. L. Storey, Derby; T. Stretch; R. White.

BRAHMA FOOTRAS.—*Any Variety*.—1, Hon. Miss D. Pennant. 2, W. Whiteley, Sh. field. 3, J. Thornton, Edge Hill, Sheffield. *Chickens*.—1 and Cup, W. A. Taylor. 2, J. Sichel, Timperley. 3, Dr. Holmes, Whitecoats, Chesterfield. *c*, W. Whiteley; J. Thornton.

HAMBURGERS.—*Gold-pencilled*.—1, H. Beldon. 2, H. Pickles, jun., Earby, Skipton. 3, J. Preston, Alerton, Bradford. *Chickens*.—1, H. Pickles, jun. 2, H. Beldon. 3, Duke of Sutherland. *hc*, J. Preston; J. Webster, Whitby. *c*, S. Smith, Northowram, Halifax. *Silver-pencilled*.—1 and 3, H. Beldon. 2, Duke of Sutherland. *Chickens*.—1, H. Beldon. 2, H. Smith, Keighley. 3, Duke of Sutherland. *Gold-eyebled*.—1, T. Walker, jun., Denton, Manchester. 2, H. Pickles, jun. 3, J. Buckley, Tannock, Ashton-under-Lyne. *hc*, H. Beldon; J. Walker, jun.; J. Ogden, Holtwood, Manchester; T. Boulton, Hanford; S. Soken-Treat, *Chickens*.—1 and Cup, H. Beldon. 2, J. Ogden. 3, J. Buckley. *hc*, T. Walker, jun.; T. Boulton. 1 and 3, H. Beldon. 2, D. Lord, Stacks-Leads. *hc*, G. & J. Duckworth, Canal Mill, Church; G. C. Hol, Lawton, Cheshire; S. Smith, Northowram, Halifax. *Chickens*.—1, H. Beldon. 2, T. Fawcett, Baildon, Leeds. 3, D. Lord. *hc*, G. & J. Duckworth. *Black*.—1, D. Walker, jun. 2, H. Beldon. 3, H. W. Ilmworth. *Chickens*.—1, C. Sidgwick. 2, W. A. Taylor. *hc*, J. Halliday, Keighley; J. Greenwood, Keighley; J. Walker, jun. (2); D. Clayton, Alerton, Bradford; W. Meddison, Glossop; Garside & Knott, Slaithwaite; T. Fawcett.

PLANDS (Any variety).—1, T. Dean, Keighley. 2, J. S. Senior, Dewsbury. 3, H. Pickles, jun. *hc*, H. Beldon. *c*, H. Beldon; P. Unsworth, Newton-le-Willows. *Chickens*.—1 and *hc*, T. Dean. 2, H. Beldon. 3, H. Pickles, jun.
FARMYARD CROSS or ANY OTHER VARIETY.—1, H. Beldon. 2, J. Sichel. 3, Mrs. J. Cross.

SELLING CLASS.—1, Baxter & Dawson, Idle. 2, W. A. Taylor. 3, D. Cartwright, Hill, Holmbyth. *hc*, H. Beldon; G. Sidgwick; J. J. Booth; C. W. Brierley; W. Whiteley; J. Roberts. *c*, J. Barker, Alerton, Bradford; T. Sharpe, Ackworth, Pontefract; E. Shaw, Plas Wilnot, Oswestry; W. J. Cope, Barisley.

BANTAMS.—*Black*.—1, W. H. Robinson, Keighley. 2, S. S. Mossop, Long Sutton. 3, Hudson & Barnip, Epsworth. *hc*, H. Beldon. *c*, J. Walker, Halifax; S. & R. Ashton, Mottram, Cheshire. *White*.—1, E. Winwood, Worcester. 2, Rev. F. Scarie, Newmarket. 3, H. Beldon. *Game*.—1 and Cup, W. Rogers, Sunderland. 2, J. Hudson, Great Horton, Bradford. 3, W. Bantley, Scholes, Cleckheaton. *hc*, J. Bamires; W. H. Newsome, Holbeck (2); J. C. Taylor, Oaklands, Leeds; S. Smith, Northowram, Halifax. *c*, S. S. Mossop. *Any other Variety*.—1, H. Beldon. 2, T. C. Harrison, Hull. 3, W. J. Cope, Barisley.

TURKEYS.—1, E. Leech. 2, F. E. Rawson, Thorne, Halifax. 3, Rev. G. Hunter, Stillingfleet, York. *hc*, Capt. Gunter, Wetherby.

GEES.—*White*.—1, E. Leech. 2, Rev. G. Hunter. 3, J. F. Absom, Kippax Lock, Greengate, Mottled.—1, E. Leech. 2, S. H. Scott, Rochdale. 3, Rev. W. Hunter. *hc*, H. Wise, Whitby; H. Horton, Bradford. 2, W. Crossley, Halifax.
DUCKS.—*Aylesbury*.—1, F. Leech. 2, W. Stonehouse, Whitby. 3, T. Wilson, Crosshills, Leeds. *Toucan*.—1, J. Sooton. 2, J. White. 3, E. Leech. *hc*, J. Newton; S. H. Stott. *c*, J. J. Waller, Kendal. *Any other Variety*.—1, S. Burn. Whitby. 2, T. C. Harrison. 3, C. N. Deaer, Chelsea. *hc*, S. & K. Ashton, C. Rev. G. Hunter.

CAMBERS.—1 and 2, E. Horner, Harewood. *hc*, E. Walker, Leicester. *hc*, H. Yardley, Birmingham.

POULDS.—1 and 2, E. Horner. *hc*, H. Adams, Beverley. *c*, J. Hawley, Digby.

TIMBLES.—*Short-faced*.—1, E. Horner. 2, C. Aton, York. *Any other Variety*.—1, J. Hawley. 2, G. H. Hirst, Marygate, York.

OWLS.—1, H. Adams. 2, Withheld.

FANTALS.—1, H. Adams. 2, J. F. Loversidge, Newark-on-Trent. *hc*, E. Horner.

FAGONS.—1, J. Firth, Dewsbury. 2, J. W. Cannon, Bradford. *hc*, H. Yardley. *Any other Variety*.—1, R. Patterson, Melrose. 2, W. B. Van Haansbergen, Newcastle-on-Tyne. *hc*, Clayton & Bairdow, Gillingham, Bradford; E. Horner. *c*, E. Horner.

JACOBS.—1, E. Horner. 2, W. B. Van Haansbergen. *hc*, J. Hawley; E. Horner. *c*, R. G. Sanders, Leven, Beverley.

TRIEMPTERS.—1 and *hc*, J. Hawley. 2, E. Horner.

NEWS.—1, W. B. Van Haansbergen. 2, H. Yardley.

DEACONS.—1, P. Giddan, South Harehead. 2, A. W. Weir, Lowestoft. *hc*, T. Kaye, Honby, Hundersfield; J. Hawley; H. Adams; F. Graham.

ANTWERPS.—1, H. R. Wright, Heckley, Birmingham. 2, H. Yardley. *hc*, W. A. Taylor. (The whole class commended.)

MAGPIES.—1 and 2, E. Horner. *hc*, J. Caudale, Copt Hewick, Ripon; H. Yardley.

ANY OTHER VARIETY.—1 and *hc*, W. C. Dawson, Olney. 2, E. Horner.

SELLING CLASS.—1 and *hc*, W. C. Dawson. 2, Clayton & Bairdow, Gillingham, Bradford. *c*, E. Horner.

RABBITS.

YELLOW AND WHITE AND TORTOIS-SHELL.—1 and Medal, A. H. Easten. 2, C. King, St. John's Wood, London. *hc*, Mrs. Arkwright, Sutton Scarsdale, Chesterfield; J. Quick, St. John's Wood, London; A. H. Easten. 3, D. Pickles, jun., Leeds; G. H. Hirst.

BLACK AND WHITE.—1, A. H. Easten. 2, G. H. Hirst. *hc*, J. Jones, Leeds; C. King.

SELF-COLORED.—1 and 2, G. H. Hirst. *hc*, J. Armstrong, Leeds.

GREY AND WHITE.—1, H. J. Tomkinson, Barton-on-Umber. 2, A. H. Easten.

SELLING CLASS.—1, C. Gravid, jun., Thorne, Doncaster. 2 and *c*, G. H. Hirst. *hc*, J. Quick.

JUDGES.—*Poultry*: Mr. Edward Hewitt, Sparkbrook, Birmingham; Mr. James Dixon, North Park, Bradford. *Pigeons and Rabbits*: Mr. T. C. Esquilant, Effra Road, Brixton, London.

EAST KENT POULTRY SHOW.

THIS was held at Ashford, December, 12th and 13th. There were upwards of 400 entries of Poultry and Pigeons, among which the following awards were made:—

DORRINGS.—*Coloured*.—*Hens*.—1, G. W. Greenhill, Ashford. 2, R. Cheesman, Westwell. *c*, J. Norwood, Mersham. *Chick*.—1, B. Smith, Ashchurch; Rev. T. E. E. Greenhill. 2, J. Norwood. *Mercham*. *Cock*.—1, J. Smith, Shilling Park, Patwryth. 2, Rev. E. Bartrum, Great Larkhamstead. *hc*, Miss Hales. *Pullets*.—1, Rev. T. E. Cato. 2, G. W. Greenhill. 3, R. B. Curteis, Ashenden. *hc*, G. C. Merton, Dover; R. B. Curteis (2); Mrs. E. C. Lee, Penhurst. *Cockerel*.—1, F. Merton, Smethth. 2, R. B. Curteis. *hc*, E. Hare; R. Cheesman; R. B. Curteis. *c*, G. Hine, Westcott, Dorking. *Silver-Grey*.—*Hens*.—1, G. W. Greenhill. 2, O. E. Cresswell, Hanworth Rectory. *c*, J. Norwood. *Cock*.—1, E. Greenhill, Little Chart, Ashford. 2, W. H. James, Ashchurch. *Pullets*.—1 and Cup, G. W. Greenhill. 2, J. Scott. 3, J. B. Plumtree. *hc*, F. Cheesman. *c*, C. A. Plumtree, Wingham. *Cockerel*.—1, B. Smith. 2, J. B. Plumtree. 2, J. Scott. *Elmsted*. *c*, J. B. Plumtree; F. Cheesman (2). *White*.—1, G. Hine. 2, J. Norwood. *hc*, Lady Dering, Surrenden, Ashford.

SPANISH.—1, Nichols & Howard, Canterbury. 2, C. S. Hammond, Ashford, *Chickens*.—1, Nichols & Howard. 2, W. Moss, Birchington, Margate. *hc*, J. H. A. Jenner, Battle. *c*, C. S. Hammond. *Cockerel*.—1, Nichols & Howard.

COCHINS.—1, Cranston & Duff. 2, Miss Hales. 2, W. White, Canterbury. *Any other Variety*.—1 and Extra, Miss Hales. 2, T. G. Ledge, Folkestone.

BRADIA FOOTRA.—*Dark*.—1 and Extra, W. Jacob, Shepherdswell, Dover. 2, H. H. Stickings, Ashford. *Light*.—1, G. Mills, Dover. 2, Miss Hales.

GAME.—*Black-breasted or other Reds*.—1, J. Jeken, Eatham. 2, G. Braham, Folkestone (Brown Reds). 3, J. H. Bayley, Ashford (Black Reds). *Chickens*.—

1, F. Rice (Black Reds). 2, M. Tomkin, Wittersham, Eye (Black Reds). 3, T. G. Ledger (Black-breasted Red). *he*, J. Jenkin (Black-breasted Red). *Any other Variety*. 1, E. Rice (Duckwing). 2, S. Muthew, Stowmarket (Duckwing). 3, Capt. Lamb, Canterbury (Blue Felt Penn). *Chickens*. 1 and Cup, and 2, J. Jeken (Duckwings). *he*, W. Foster, Deal (Duckwing); Mrs. E. C. Lee (Duckwing). *Cock*.—1, J. Jeken. 2, E. Rice (Duckwing). *he*, H. Lowe, Chatham. 3, C. Rogers, Hastings; G. Braham.

HAMBURGERS.—*Gold-spangled*.—1, W. W. Tickner, Ipswich. 2, Rev. F. T. Scott. 3, W. Taylor, Maidstone. *J. Dutton*. *Silver-spangled*.—1, M. Dorman, Ashford. 2, J. H. Hely, Lowestoft. *he*, W. Taylor. 3, Mrs. C. Russell, Ashford *Game*.—1, Mrs. J. P. G. H. Ashford. 2, P. Griffin, Folkestone. *he*, W. W. Tickner; W. Robinson, Ashford. *Silver-penciled*.—1, Withheld. 2, G. Hine. *POLISH*.—1 and 2, T. Griffin. 3, E. J. Reeves, Haywards Heath; Miss Hales. **CARVE-CRENS**.—1, W. Dring, Faversham. 2, Rev. H. H. Dombain, Westwell. 3, T. G. Ledger.

HOUDAN.—1 and Extra, Hills & Co., Brighton. 2, H. S. Fraser, Headley, Liphook. 3, G. Mills.

BANTAMS.—*Gold and Silver-laced*.—1, Mrs. E. C. Lee. 2, Withheld. *Black, White, or any Variety*.—1, Miss E. J. N. Hawker, Wyellife, Tunbridge Wells (Silky). 2, F. G. Phillips, Hastings (Black).

GAME BANTAMS. 1, Nichols & Howard. 2, H. Simmonds, Reigate. 3, Rev. E. S. Tiddeman (Childeritch Vulture). *he*, H. Lowe. 3, J. B. Plumpton.

DUCKS.—*Aylesbury*.—1, W. Jacob. 2, W. Young, Kennington, Ashford *he*, G. W. Greenhill. *Rouen*.—1, C. S. Hardy, Chatham Castle. 2 and *he*, W. F. Harvey, Thurly, Chatham.

TURKEYS.—1, Mrs. H. H. Ashford. 2, W. S. Powell. *he*, D. Swaffer, inn, Kingsworth, Ashford. *Goslings*.—1, Mrs. S. Powell, East Lenham. 2, W. H. Mold, Bathersden. *he*, C. Rogers, Ashford.

TURKEYS.—1, C. S. Hardy. 2, J. Fould, Westwell. *he*, Miss Hales; E. H. K. Huggess, M.P., Ashford. 3, W. H. Mold. **POULTS**.—1, Rev. N. J. Ridgely, Houghton House, Newbury. 2, W. B. Sharp. *he*, C. J. Plumpton. 3, J. Fould; C. S. Hardy.

ANY OTHER VARIETY.—1, J. Brissenden, Canterbury (Black Gelder). 2, Countess of Aylesbury, Farningham Hall, Kent (Cuckoo Dorking). *he*, Rev. N. J. Ridgely (Malay); Miss Hales (Andalusian). 3, E. J. Reeves (Sultan).

PIFFONS.—*Carriers*.—1, J. Bowes, Hemo Bay. 2, W. Foster. 3, G. Wise, Preston, Faversham (2); W. Foster. **POUTERS**.—1, J. F. Loveridge, Newark. 2 and 3, J. Bowes. **TUMBLERS**.—1, J. Bowes. 2, W. Irlesden, Ashford. **FANTAILS**.—1, A. A. Vander Meersch, Perry Hill, Sydnam. 2, J. F. Loveridge. 3, G. W. Greenhill. *Any other Variety*.—1, A. A. Vander Meersch. 2, J. Bowes (Black Barbs). 3, Miss Hales (Runts). 3, Miss Hales (Trumpeters); A. W. Wren, Lowestoft (Yellow Francos).

JUDGE.—Mr. Tegetmeier.

WEST HERTS AGRICULTURAL SOCIETY'S POULTRY SHOW AT WATFORD.

AGRICULTURE would seem to flourish in the good county of Hertfordshire, and the uses of competition having made themselves patent, a locale was wanted where produce could be exhibited. Hence the building in which this Show was held, a truly excellent one for the purpose. It is a large square building, with moveable iron fittings for cattle of every description. All the modern appliances have been adopted. Although cattle is not our vocation, we cannot help noticing the ingenious and comfortable way of tying them, and the excellent contrivance for putting up the eards. The cattle, sheep, pigs, and roots occupied the floor, while the poultry were comfortably ranged in the spacious gallery that surrounds the building and would afford good accommodation for a greatly increased number. We were very glad to hear, that by being let for many useful purposes, the interest of the sum expended is already provided for at five per cent. The hearts of the good folks of Hertfordshire seem to be inclined towards boeotic pursuits, and the things that belong to them. There were eight cups or pieces of plate of five guineas each, offered for different breeds, and a silversmith attended with a tempting display of articles from which the fortunate could choose.

This is entirely a local Show, and we are glad to be able to speak most favourably of the entries. The *Dorkings* were excellent, so far as the Greys were concerned, but the *White* were represented only by one very worthless pen. *Partridge Cocks* were here shown in that which they require, a staring light, and we thought them better than at Birmingham. Lord Chesham carried off the cup. The *Buff Cochins* are decidedly not favourites in agricultural districts, or if they are, not in Buff classes. While there were thirteen of the Partridge, there were only three of any other variety, and those of such poor character that the first prize was withheld. The *Brahmas* were very good, both Light and Dark. Few of the pens of *Game* were dubbed, but many were very good. If it be adopted, as at large and general shows, that all birds be dubbed, notice should be given to exhibitors that birds with combs and gills will be disqualified. The *Hamburgers* were far above the average at local shows. *Game Bantams* were well represented, and successful over their competitors. It was curious that in their native county *Schripts* were not forthcoming.

All the birds of which we have treated were chickens of 1870, but the next was a class *sui generis* for all breeds and all ages, but no pen to exceed £2 in price. It brought a good show of different breeds. There was an excellent show of *Rouen*, but a poor show of *Aylesbury Ducks*. The latter do not show well anywhere in comparison with their antagonists. The *Geese* were very good, but as usual the *Toulouse* were the heaviest. There were some good *Saddlebacks*. The *Turkeys* were excellent. It will be seen that the result of this Show is to prove that the poultry question is looking up—that in a limited area the farm poultry—i.e., *Dorkings*, *Geese*, *Turkeys*, and *Ducks*, are all largely represented as farm stock shown by those engaged in agriculture. We take this to be the aim of such societies, and we congratulate them on their deserved success.

DORKINGS.—*Coloured*.—1 and Cup, Rev. E. Bartrum, Great Berkhamstead. 2, J. H. Barnes, Rickmansworth. *he*, Rev. E. Bartrum; C. Snewing, Holywell, Watford.

COCHINS.—*Partridge*.—1, 2 and Cup, Lord Chesham, Chesham. *he*, C. A. Barnes; T. Clutterbuck, Rickmansworth; R. Horsfall, Watford. 3, R. Horsfall. *Any other Variety*.—1, Withheld. 2, R. Horsfall.

BRAHMA POOTRA.—*Dark*.—1, Mrs. King, Watford. 2, R. Horsfall. *he*, T. Clutterbuck; R. Horsfall. *Light*.—1, Lord Chesham. 3, R. Horsfall. **GAME** (Any variety).—1 and Cup, T. Paramor, Eldreth. 2, W. F. M. Copeland, Watford.

HAMBURGERS (Any variety).—1, A. J. Copeland, Upper Nascott. 2, R. L. James, Watford. 3, E. Moon, Watford (2).

BANTAMS.—*Game*.—1, Lord Chesham. 2, C. Waghorn, St. Albans. *Any other Variety*.—1, Lord Chesham. 2, Withheld. **CARVE-CRENS AND HOUDANS**.—1, T. Clutterbuck. 2, A. T. Brett, M.D., Watford House.

ANY OTHER VARIETY.—1, A. J. Copeland (Dorkings). 2, E. Bartrum (Dorkings). *he*, C. A. Barnes (Brahms); Mrs. King (Game); E. Majoribanks, Bashey (Dorkings); R. Horsfall (Partridge Cocks).

DUCKS.—*Aylesbury*.—1, Lord Chesham. 2, G. Waghorn. *Rouen*.—1, C. A. Barnes. 2, W. F. M. Copeland. *he*, C. A. Barnes; E. Moon. 3, E. Moon. *East Indian*.—Frize, C. A. Barnes.

ANY OTHER DISTINCT BREED.—1, T. Clutterbuck. **GEESE** (Any variety).—1 and 2, C. A. Barnes. *he*, J. H. Barnes. 3, G. Stone, Watford.

TURKEYS (Any variety).—1 and Cup, R. Blackwell, Chipperfield. 2, W. J. Loyd, Langleybury, Watford. *he*, C. A. Barnes; G. P. Dodge, Rickmansworth; W. J. Loyd. 3, C. Longland, Stensish, Hemel Hempstead; T. Paramor.

JUDGES.—The Rev. G. F. Hodson, Mr. Baily, and Mr. Botham.

BINGLEY PIGEON SHOW.

This was held on the 16th and 17th inst. The awards are as follow:—

POUTERS.—*Cock*.—1, G. Strassers, Leicester. 2, E. Horner, Harewood, Leeds *he*, W. Harvey, Sheffield. *he*, E. J. Dew, Weston-super-Mare; G. Strassers; E. Horner; E. P. Moon. *Hens*.—1, Cup, and 2, E. Horner. *he*, G. Strassers; W. Harvey; G. Strassers.

CARRIERS.—*Cock*.—1, E. White, Birmingham. 2, E. Horner. *he*, E. Smith, St. Albans, Birmingham; T. Colby; G. J. Taylor, Huddersfield (2). 3, T. Colby, Sheffield. *Hens*.—1, Cup, and 1, G. J. Taylor. 2, E. Horner. *he*, W. H. Stichey, Mosely, Birmingham; E. Horner; G. J. Taylor.

TUMBLERS.—*Almond*.—1, E. Horner. 2, W. Harvey. *he*, E. J. Dew. *he*, G. J. Taylor; J. Stanley, Blackburn; H. Yardley, Birmingham; J. T. Lishman, Gillingham. *Any other Variety of Short faces*.—1, F. Moore (Black Kite). 2 and *he*, G. J. Taylor (Yellow). 3, W. Kitchen, Burnley. *Common*.—1 and Cup, W. Harvey. 2, J. F. Lishman.

BARBS.—1 and 2, J. Firth, Dewsbury. *he*, J. Thresh, Shipley; H. Yardley; E. Horner.

OWLS.—*Foreign*.—1, J. Fielding, jun., Rochdale. 2, J. Stanley. *he*, W. C. Dawson, Otley; W. Harvey. *English*.—1, T. Newell. 2, T. Waddington. *he*, J. G. Golden, jun., Hale, Altrincham; J. W. Edge; J. Crossland, jun., Wakefield.

JACOBIANS.—1, E. Horner. 2, J. W. Edge, Birmingham. *he*, J. Newell, Ashton-under-Lyne. *he*, W. B. Van Haansbergen, Newcastle-on-Tyne.

TURBOTS.—1, W. B. Van Haansbergen. 2, J. Firth. *he*, W. H. C. Oates, Besthorpe; E. Horner (2); J. Hawley (2); J. Firth. 3, J. Hawley.

TURBOTS.—1, J. W. Edge. 2, G. South, East Acton. *he*, O. E. Creswell, Hanworth Rectory; J. Fielding, jun.; W. Lund, Shipley; W. B. Van Haansbergen. 3, E. J. Dew.

DAKONS.—1 and Cup, J. Holland, Manchester. 2, G. South. *he*, F. Graham, Birkhead.

FANTAILS.—1 and Cup, J. Sharp. 2, Rev. W. Sergeantson, Acton Burnell. *he*, W. Edge; H. Yardley; W. Harvey.

ANTWERPS.—1, E. Horner. 2, J. A. Collinson, Halifax. *he*, R. Sidwick, Kockley; J. Broadbent, Denton; H. R. Wright, Hockley, Birmingham (2); W. H. Mitchell; J. Deakin, Sheffield; J. Crossland, jun. 3, J. A. Collinson.

ANY OTHER VARIETY.—1, W. C. Dawson (2). 2, W. Harvey (2). *he*, E. Horner; T. Waddington (Spud); J. T. Lishman (Black Swallows); J. Hinks, jun., Birmingham (Red Swallows).

SPRINGING CLASS.—1, E. Bellon, Bradford (Red Barbs). 2, J. T. Lishman Blue Owl. *he*, J. E. White. 3, W. Kitchen (Dragon). Extra Prize to the exhibitor obtaining the most points, E. Horner.

JUDGES.—Mr. T. J. Charlton, Bradford, judged the classes for Pouter cocks, Pouter hens, Carrier cocks, Barbs, Foreign Owls, Jacobins, Fantails, English Owls, and Antwerps; and Mr. T. H. Ridpath, Manchester, judged the remaining classes.

SCOTTISH COLUMBARIAN SOCIETY'S SHOW.

This Show was held on the 15th and 16th inst., in the Music Hall, George Street, and was a great success. We must defer detailed remarks till next week.

YOUNG BIRDS.

POUTER COCKS.—*Black*.—1, 3, *he*, and 3, G. Ure, Rosebank, Dundee. 3, J. Wallace. *White*.—1, J. McGill, Elie. 2, W. Moon, 3, J. Fairley, Edinburgh. 3, W. Pathford, Edinburgh. *he*, G. H. W. Volekman, Edinburgh; J. Cars, Edinburgh. *Blue*.—1, W. Volekman, Bishopscate Street Within, London. 2 and Special, J. Millar, Glasgow. 3, J. Morrison, Morningside, Edinburgh. *he*, M. Stuart. *Glasgow*. 3, G. Ure (2). *Red*.—1, W. Volekman. 2, J. Millar. 3, R. Fulton, Don Road, London. *Yellow*.—1, E. Horner, Harewood, Leeds. 2, G. Ure. 3, A. Wright, Morningside, Edinburgh.

POUTER HENS.—*Black*.—1, G. Ure. 2, J. Millar. 3, J. Mitchell. 3, J. Hnie, Glasgow. *White*.—1, J. McGill, Elie. 2, W. Moon. 3, J. Fairley, Edinburgh. 3, W. Rutherford, 3, E. Horner. 1, M. Stuart. 2, G. Ure. 3, J. Millar. *he*, W. Volekman; F. Horner. 3, J. Mitchell, Glasgow; J. Blair, Edinburgh. *Red*.—1, A. Wright. 2, G. Ure. 3, G. Taylor, Edinburgh. *Yellow*.—1, J. Wallace, East Glasgow. 2 and 3, G. Ure. *he*, W. Volekman. 3, G. Ure; R. Fulton.

CARRIER COCKS.—*Black*.—1, E. Horner. 2 and 3, G. C. Holt, Lawton, Cheshire. *Dun*.—1, R. Fulton. 2 and 3, G. C. Holt.

CARRIER HENS.—*Black*.—1, G. C. Holt. 2, R. Fulton. 3, E. Horner. *Dun*.—1 and 2, G. C. Holt. 3, E. Horner.

ARM AND TUMBLERS (Short faced).—1, W. R. & H. O. Hinkinson, Newcastle Barbs. —1, R. Fulton. 2, W. Massey, Spalding. 3, G. C. Holt. 3, G. White Ladyburn, Paisley.

FANTAILS.—1, G. Ure. 2 and 3, J. Hnie. **TRUMPETERS**.—1 and 2, T. Rule, Durham. 3, J. Wallace (Black).

OLD BIRDS.

POUTER COCKS.—*Black*.—1, R. Fulton. 2, 3, and *he*, G. Ure. 3, J. Millar. *White*.—1, M. Sanderson, Edinburgh. 2, W. Rutherford. 3, J. Wallace. *he*, J. Porteous, Edinburgh; R. Blair, Edinburgh; J. Ruthven, Pollockshields, Glasgow. 3, W. Hendrie, Aberdeen; J. Hnie. *Blue*.—1 and 2, R. Fulton. 3, J. Spruell, Glasgow. *he*, M. Stuart; D. Stewart, Perth; R. Fulton; J. Hnie. 3, M. Sanderson. *Red*.—1, A. Wright. 2, R. Fulton. 3, J. Main, Kilmarnock. *he*, J. Bruce, Dunfermline; R. Fulton. 3, G. Ure; R. Fulton. *Yellow*.—1, W. Volekman. 2 and 3, R. Fulton. *he*, G. Ure. 3, M. White, Dunfermline. *Any other Colour*.—1 and 2, W. Volekman (Mealy). 3, J. McGill (Chequer). *he*, D. Stewart (Splash); W. Volekman. 3, D. Stewart (Mealy); J. Ruthven (Splash).

POUTER HENS.—*Black*.—1 and Special, R. Fulton. 2, J. Hnie. 3, J. Millar. *he*, M. Stuart; J. Wallace. *White*.—1, R. Fulton. 2, M. Stuart. 3, J. Rutherford. *he*, J. Wallace. 3, R. Blair; C. Thomson, Broughty Ferry. *Blue*.—1 and 2, R. Fulton. 3, J. Millar. *he*, G. Ure; R. Fulton. 3, T. Duncan, Dal-

keith; J. Lnis, Edinburgh. *Red*.—1, J. Millar. 2, R. Fulton. 3, M. Sanderson. *hc*, J. Morrison. *c*, J. Huic. *Yellow*.—1 and 2, R. Fulton. 3, A. Wright. *hc*, G. Ure. *c*, G. Ure; R. Fulton; W. Volckman. *Any other Colour*.—1 and 3, W. Volckman. 2, J. Ruthven. *hc*, W. Moon (Splashed); J. Carss. *c*, J. Bruce; D. Stewart (Checker).

CARRIER COCKS.—*Black*.—1 and 2, R. Fulton. 3, W. Massey. *Dun*.—1 and 2, R. Fulton. 3, W. Massey.
CARRIER HENS.—*Black*.—1, 2, and 3, R. Fulton. *Dun*.—1, 2, and 3, R. Fulton.
ALMONDS.—*Short-faced*.—1, W. R. & H. O. Blenkinsop. 2 and 3, R. Fulton. *Any other Colour*.—1, R. Fulton. 2, W. R. & H. O. Blenkinsop. 3, J. Wallace (Kites). *hc*, J. Bruce.

FARUS.—*Black*.—1 and 2, R. Fulton. 3, J. Wallace. *Any other Colour*.—1, J. Fielding, jun., Redclife (Yellow). 2 and 3, R. Fulton (Red and White).

FANTAILS.—1, T. Wilson, Stewarton, Ayr. 2, A. Lookhart, Kirkcaldy. 3 and *hc*, G. Ure. *c*, J. H. Bruce.

TROUSERS.—1 and 2, R. Fulton. 3, J. Wallace (Red).
JACOBINS.—1, T. Rule. 2, H. L. Tivy, Cork (Mottled). 3, W. R. & H. O. Blenkinsop.

OWLS.—1, J. Fielding, jun. 2, R. Fulton. 3, W. Goldard, Earlston (White).
TURKETS.—1 and 2, Capt. Bolton, Trinity, Edinburgh. 3, T. Rule. *c*, R. Paterson, M. Rose (Blue); J. R. Rennards, Helensburgh (Red); W. R. Park, Abbots Meadow, Melrose (Blue); H. L. Tivy.

NEWS.—1, W. R. Park, Hill. 2, C. Thomson. 3, M. White.
MAGPIES.—1, J. Grant. 2, E. Horner. 3, G. B. Phillips, Ayr.

FLYING TUMBLERS (Any colour).—1, J. Sharp (Mottled). 2, J. M. Braid, Cambridge (Baldheads). 3, T. Rule.

ANY OTHER VARIETY.—1, Capt. Bolton (White Runts). 2, J. Wallace (Alyssians). 3, E. Horner. *hc*, W. R. Park (Lutz); J. Wallace (Damascene). *c*, W. Goldard (Austrian Pouters); J. Wallace (Lace Fantails).

JUDGES.—Mr. D. Wolstenholme, and Mr. E. L. Corker.

TREDEGAR POULTRY SHOW.

This year the entries at Newport were considerably more numerous, and the quality much better, than at any previous show, although five other shows were held on the same date, and this we attribute to the general good management and courtesy of the Secretary, Mr. Palling, whose efforts were well seconded by Mr. Nicholas and other members of the Committee.

On our left on entering we found the *Game* classes, the Black and Brown Reds being in the first position on the schedule; and in this class Brown Reds were first with the cup for the best pen of *Game*, but were closely pressed by a pen of adult Piles in the following class. There were also some good Duckwings, but the hens were mostly a little coarse in colour and marking. Of *Spanish* there were some capital birds, but the cocks were superior to the hens, some of the latter being a little coarse in comb; the cock in the cup pen was a gem, and in fine condition. The *Dorkings* were of large frame, the feet, as a rule, very good, and the colour of the Dark Greys very sound. There was one pen of Silver-Greys which would, doubtless, have had first honours had it not been for the excessive marking on the hackle of the cock; as it was, the first and cup for *Dorkings*, also the piece of plate, value £28, for the best pen in the Show, were won by dark Rose-combed birds. This was contrived by a few gentlemen of the locality, at the head of whom was the Mayor of Newport. Buff *Cochins* were good, with the exception of a little mealiness on the tails and wings of some of the old birds, though the colour of the winners was faultless. Partridge were a good lot, the hen in the first-prize pen being one of the best faced birds we ever saw, and both birds perfect in style and feather. The cup for this section was won by this pen. There were some nice Whites, but the best pen arrived too late for competition. Light *Brahmas* were much superior to those at any previous show, yet many of them were wanting in marking on the hackles and tails. The Dark *Brahmas* were numerous, and the commendations widely diffused. As a rule, the cocks of this colour were better than the hens; the hens that were best in shape, size, and facing being mostly too brown on the ground colour—a fault that cannot too quickly disappear.

Next were the *Hamburgh* classes, and these were well represented, the cup going to Silver-spangled. The Golden-pencilled were an even lot, and the contest keen. The Silver-pencilled were also good, but not equal to the Golden variety; and in the Gold-spangled we thought the hens superior to the cocks, some of the latter being too high in comb, though the winning birds were good in that respect. Of *Pouter*s there were but three pens, all Silvers, and good in all points. The *French* fowls were represented by two classes, the *Hondans* being large and well marked, although some of the cocks had more of the *Crève-Cœur* comb than that of the *Hondan*. In the next class *Crève-Cœur*s were first, and took the cup for the best pen of French fowls, and *La Fleche* second. There were four classes for *Bantams*, the first of which was for *Game*. There were several smart pens, the winners being Black Reds, with Duckwings highly commended. Of Blacks, some of the birds were not good in comb; but throughout, the earlobes were perfect and the plumage very good. The only fault we found with the first-prize pen was that they were a little too large, though in all other points quite to our liking. In Whites Messrs. Ashton won with a very fine pen, the plumage being perfect; and in the "Variety class" the winners were both Silver *Sébrights*, the marking of which was very good. In the "Any other variety class" the first prize went to very neat Black *Hamburghs*, the second to Malays, the third to White *Dorkings*, and the fourth to *Sultans*.

Ducks were very numerous, both *Aylesbury* and *Ronen* being large and good in bill and plumage, though among the *Ronens* were several birds with leaden-coloured beaks, which are altogether inadmissible in a prize pen. That most attractive and ornamental section of aquatic birds, "the *Variety class*," was well filled, and great difficulty was experienced in making the awards, there being so many good pens that more prizes could have been worthily awarded.

Geese and *Turkeys* were quite up to the mark. In the former class Mr. Fowler won with a very large pen, though not quite to our liking in colour. The winning *Turkeys* were Cambridge.

There were two selling classes, one for fowls and the other for Ducks, and both were well supported with cheap lots, which offered great advantages to intending purchasers.

There were some good birds in all the *Pigeon* classes, and these might be extended with advantage, only nine classes being devoted to them. Mr. Yardley won the plate for the best pen of *Pigeons*, although Mr. Hawley was in dangerous proximity with a grand pair of Black *Trumpeters*. In the "Variety class" Nuns were first, Black Swallows second, Mated *Pigeons* third, and Barbs fourth. We published the prize list last week.

GUILDFORD POULTRY SHOW.

This is one of the pleasant local gatherings that warn us of the approach of Christmas. It took place on the 12th and 13th inst., in connection with a show of fat stock. The whole of the Exhibition was formerly held under the same roof, but it has grown and expanded till it requires a separate building for the poultry.

It will readily be supposed that in Surrey the *Dorkings* would muster in strength. Being confined to a small area, the competition would appear small in numbers as compared with those that are open to all England, but we have no hesitation in saying the birds successfully shown at Guildford would have been prize birds at Birmingham. We have seldom seen better, and we could not help thinking it was a pity the Committee did not remove all restrictions, and throw down the gauntlet to England. The White *Dorkings* were very good. The third class is peculiar to Guildford. It is made-up of birds called in this part of Surrey Blue *Dorkings*, but known elsewhere as *Cuckoos*. There was a capital entry of good birds. A most excellent pen was shown by one of the Committee, who, with a delicacy that is worthy of imitation, declined to compete because he held office. The *Spanish* were good, but not so numerous as we have seen on other occasions. The *Cochins* were a failure in every respect, and the first prize was withheld. So long as the Show is a local one, we almost doubt the wisdom of continuing the class. There is always a good show of *Brahmas*, especially of Light birds exhibited by Mr. Pares, who may, we believe, be called the originator of the Light classes. Two pens of good Dark birds were disqualified in this class, the legs being distinctly marked with string and tape.

The entries of *Game* were small, and many pens were shown in which the cocks were not dubbed. There are always good *Hamburghs*, and this year they formed no exception. The *Bantams* were well represented. The Black Red *Game* birds of these classes, now carefully bred, are fast attaining the perfection of their larger namesakes. The entries of *Ducks* were good, but here, as elsewhere, the *Ronens* in every way surpassed the *Aylesbury*. They were excellent in weight and feather. The "Variety class" brought *Summer* and *Calls* as usual. The *Geese* and *Ducks* are always good here. They would have been noticed anywhere. The Toulouse as usual carried off the former prize. The curious-looking *Sebastopol* may be among the admired, but they cannot compete with the others on the question of weight, and, consequently, of utility.

We believe this part of England is favourable to *Turkeys*, they always appear in numerous entries, and of excellent quality. There is one point we frequently notice, which is, that there seems almost a certainty of like begetting like among these birds; it almost always happens that the same exhibitor takes the prizes for young and old birds. Mr. Messenger did so in this instance. In the "Various class" there were some good *Hondans* and *Crève-Cœur*s. We were never admirers of crosses, and those we saw between *Dorking* and *Brahma*, and *Dorking* and *Cochin*, did not alter our opinion.

Mr. Baily was the Judge.

BERWICK CANARY SHOW—PRIZE LIST EXTRAORDINARY.

WHEN I received the schedule of Berwick-on-Tweed Show, and noticed on what an absurd principle the silver cup was to be awarded—viz., first prize to count 6; second, 5; third, 4; very highly commended, 3; highly commended, 2; and commended, 1, I clearly foresaw that something absurd would result. It was easy to suppose any number of cases based on these premises, which could result in nothing but an absurdity, even to the extreme case of an exhibitor winning the silver cup without taking a single prize; but I scarcely imagined that the result would, in actual fact, be such an extraordinary exemplification of the fallacious principles on which the award of the cup was made.

I will take the prize scores of the three most successful exhibitors—Messrs. Moore & Wynn, Mr. Barnesby, and Messrs. Wallace & Beloe. An analysis shows that Moore & Wynn won thirteen prizes, scoring sixty-five points; Barnesby won six prizes, scoring thirty-four points; Wallace & Beloe won six prizes, scoring twenty-nine points. Moore and Wynn's list consisted of five firsts, three seconds, and five thirds. Barnesby's consisted of four firsts and two seconds. Wallace and Beloe's consisted of one first, three seconds, and two thirds. A single glance will show the relative value of these scores. Moore & Wynn take more prizes than the other two put together, and the sum of their

prize points is in excess of the sum of the other two; yet by the aid of the very highly commended, the highly commended, and the commended scores, Messrs. Wallace & Beloe are enabled to add the large number of fifty-five points to their small twenty-nine, and carry off the cup with an aggregate of eighty-four points.

Of course, this is all according to the conditions under which the cup was to be awarded, as set forth in the schedule, and is, therefore, all strictly fair. It is only the absurdity of the conditions with which I have to do. Anyone at all acquainted with Canary shows must be aware that as an almost invariable rule (for exceptional cases are so very rare that the rule may almost be accepted as unvarying), no disposition of points can represent the relative values of the first, second, and third-prize birds, and the next half dozen below them. No handicapping can bring them together. In the majority of instances the difference between the first and second is very inadequately represented by the ratio 3:2, and the gap between the first and third is wider still, while the mathematical genius has not yet been born who can invent a scale of notation to represent in any known terms the comparison between the prize birds and the very highly commended, highly commended, and commended, which follow in a descending scale, precipitously steep, terminating in a rubbish heap.

The principle upon which commendations of any degree are awarded is different from that which regulates the awarding of the prizes. It is seldom we see two equal firsts or seconds—never, in fact, unless the judges are empowered to give duplicates, and then the wisdom of the step is questionable, and the position barely tenable; but commendations are scattered with a much more lavish hand, and any sensible man knows the value of them. Sometimes judges are instructed to be liberal in their commendations, and it is not unusual to see three or four very high commendations, and as many of the lower grades in one class. But no one will venture to say that the three or four very highly commended judged as being of equal merit are so in reality, and that it would be impossible to separate the three without an injustice to one or the other, or that the highly commended and the commended are equally inseparable. They are judged on more general terms, and may be considered as being divided into three groups, not too closely sifted and classified according to their general merit. But the most meritorious of them (and an exhibitor by entering a number of them may score many equal very high commendations, or commendations in one class), is far removed from the third-prize bird, and most certainly deserves to contribute nothing towards prize-winning.

Birds capable of holding their own against all comers are few and far between, very difficult to breed, and very valuable when obtained. Fourth, fifth, and sixth-rate birds are plentiful as blackberries, easy to breed, and not worth the seed they eat in comparison with the others. The one class, which represents an ideal standard of perfection, cannot be produced in large numbers, but the other can and is; and any man by procuring a sufficient number of them can render it practically an impossibility for an exhibitor of high-class birds to win a prize he values more than money, and a schedule has been found offering this facility. Even if there were only one very high commendation, one high commendation, and one commendation, it would be bad enough; but it is, apart from the absurdity of the thing, a manifest injustice to give one first, one second, one third, and an unlimited number of equal very high commendations, high commendations, and commendations. A silver cup does two things—it represents so many ounces troy at so much per ounce, and it also tells a story. Sardonically first, second, and third in the race were inscribed upon it, it would like to turn its face to the wall.—W. A. BLAIRSON.

FOUL BROOD.

THE above subject being again brought up, reminds me that my contributions to "our Journal" have fallen very much behind, and that I owe your esteemed correspondent, Mr. J. Lowe, an apology for not advertising sooner to his last paper on "Foul Brood," in Nos. 409 and 410, not that I have anything particularly new to communicate, but on the principle that "silence gives consent." I might be held as homologating the peculiar views put forth.

While perusing with much interest, and very great pleasure, Mr. Lowe's clever five years' *résumé* of this controversy, still I must confess it left a rather perplexing impression on the mind, to find your correspondent, who so long and persistently decided the existence of such a disease, seemingly clinging to his old hypothesis, that the appellation foul brood was synonymous with chilled brood, induced by experimenting, and curable by excision, even while quoting the ravages of the fell destroyer to the extent of one hundred colonies in one year in the American apiary of Mr. Quinby, and to no less than five hundred in 1848, in that of the German one of the celebrated Dzierzon, while endeavouring in the most ingenious manner to bend the most opposite opinions as to its origin in support of his pet theory, on no better foundation than that "extremes meet."

I quite agree with your correspondent, that "it is strange,"

on the assumption that foul brood is no disease, but simply an effect of over-experimenting, that while Mr. Quinby should have lost so very heavily, his transatlantic brother, the Rev. L. L. Langstroth, states that the malady never made its appearance in his apiaries, more particularly when it is borne in mind that the latter gentleman first introduced the frame hive, and may be held as the most experimental apiarian on that continent; and stranger still that "A DEVONSHIRE BEE-KEEPER," for whose frank and graphic description of its ravages we are all so much indebted, assures me that while "more experimental than ever," it has never re-appeared in consequence.

It was with much pleasure I accepted Mr. Lowe's proffered invitation to accompany him through his "Loz's mountain pass." We there discover the remains of what was once a living organism. While awaiting in wrapt attention his opening the inquest, my metaphorical companion, sniffing the tainted atmosphere, moves off with a rhetorical flourish, "What matters it, whether that once living form was deprived of life by frost or fire, by cold or heat, whether by an electric flash of heaven's hot artillery, &c.?" Not possibly very much to the mere theorist, but everything to the unfortunate apiarian who has had his apiary repeatedly swept by foul brood, and something, too, one would suppose in a paper treating expressly on the origin of foul brood.

Its origin in its most virulent form in my apiary, now seven years since, was clearly traceable to infection through the interchange of combs with a diseased colony received from "A DEVONSHIRE BEE-KEEPER," before he discovered the cause of his "dwindling apiary," and he in like manner introduced the disease by using infected combs from a common straw hive, which latter fact Mr. Lowe has all along very unfairly ignored.

Having suffered so severely from the devastating effects of this most mysterious malady, I must confess to have acquired such a salutary dread of the smallest trace of its insidious advance, that my efforts have all along been more directed to "stamp out," than speculate or experiment with a view to trace its origin. I can, therefore, appreciate and feel all the more grateful to such correspondents as your valued contributors, "R. S.," and "A LANARKSHIRE BEE-KEEPER," for their practical efforts in this direction.

I am still of the opinion adduced in this Journal in the beginning of 1867, that "over-heating, rather than any amount of exposure and chill, induces this most mysterious malady," and I cannot comprehend how Mr. Lowe "hails this theory as one virtually quite in accordance with my own." If we take the case of chilled brood in a hive, it has been abundantly proved that such is removed by the bees, then Mr. Lowe's argumentative structure topples over; and if the pupae die solely from contamination with those in the adjoining cells, agreeably to Mr. Lowe's theory, how comes it that we find perfectly healthy bees frequently emerge from the very centre of corrupting masses? but how opposite is the result in an "over-heated" colony. I never said nor supposed that the death of the embryo, as a matter of course, followed parallel to that of chilled brood; on the contrary, heat is what young bees can stand a good deal of. Suppose we confine the inmates of a populous hive during warm weather in summer, the temperature at once rises, undue excitement follows, vapour is seen clouding the internal atmosphere, which, condensing on the windows, trickles down in streams. No doubt, if persisted in to extremity, the bees as well as brood would be suffocated, and the combs give way; but some time before such an extremity is reached if we open the entrance the inmates pour forth in streams to the fresh air over the landing board, and on to the ground, and seem for a time as if quite paralysed; labour is brought to a standstill, and although subsequently resumed, goes on but sluggishly, and if in the course of a few days we invert the hive unmistakable traces of foul brood will be too apparent, induced, doubtless, by the effects of the heat and the condensed moisture mixing with the unsealed honey, causing it to ferment, and acting in a deleterious manner on the larvæ when fed with it. The fermentation which is a consequence of mixing even unsealed with sealed honey drained in summer, is well known to all practical bee-keepers.

Confirmatory of this view, I may narrate an interesting case I met with where foul brood was subsequently induced in a healthy hive without the presence of brood at all in the first instance. Driving, on the twenty-fourth day after swarming, a bought-in cottager's common straw skep, I could not but admire, on examining the combs, how thoroughly every bee

had been hatched out. There was not a single cell-cover visible; and the operation having taken place while honey abounded, in addition to a large weight of sealed honey in the upper portion of the combs, a considerable area of the brood cells contained unsealed honey evidently freshly gathered in. From the healthful state of matters I resolved to cover it up and set it aside for a prospective stock hive, its own population having been added to an adjoining colony. At the end of the season, having been presented with the teeming population of two capital prime swarms, of the healthful condition of whose combs I had taken care to satisfy myself, they were duly conjoined, and I prepared to look out my beat-out skep, but it was nowhere to be found. Subsequently it was discovered stowed away as lumber in a very damp apartment, and, on making an examination, I was chagrined to find that overspreading the unsealed honey there was an abominable white mouldy fungus-like growth. If I had had but a few bees at command I would have hesitated before introducing them, but the heat and capabilities of such a body of bees I thought amply sufficient to counteract any bad effects following, and they were run up, and it was set down on a stance. Being so well found in population and store, it remained untouched till the following spring was well advanced, having calculated on a particularly early strong swarm, forgetting all about the state of the unsealed honey in the combs, till one remarkably genial day my attention was arrested by the paucity of the workers emerging from it, and it was forthwith inverted, when to my great mortification I found but a very small handful of bees, and the combs one mass of putrifying corruption from foul brood. Sentence of death was at once passed on the little band, and the contents of their hive consigned to the melting pot.

The evil effects of feeding with fermented foreign honey came to my knowledge a few seasons back. An extensive cottage bee-keeper, for economical reasons, purchased a large cask of this commodity, and from its extreme cheapness fed his stock very liberally. I afterwards saw in his garden, on more than one occasion, combs in a bad state from foul brood, of which he had previously no experience, as well as colonies sold from his apiary which failed to prosper from the same cause.

I am glad to be able to report, that although employing many more frame hives than formerly, my stock has for the last two seasons regained its pristine healthfulness; and when, last season, I was kindly favoured with a new cure (permanganate of potash) for my old enemy, I had not a case to try it with, and therefore sent it on to my friend "A STEWARTON APIARIAN," whose unsuccessful experiment has been already chronicled in these pages.—A RENFREWSHIRE BEE-KEEPER.

OUR LETTER BOX.

MORLEY SHOW.—Are other exhibitors like myself? I have received no prize money awarded to me at the last Morley Show. I have applied several times to the Secretary and received no answer.—H. W. HILLINGWORTH, *The Green, Idle, near Leeds*.—[Give the Secretary notice that you will see him in the County Court.—EDS.]

EARLOES OF DORCHES (H. S. D.).—The earloes of a Dorking is quite immaterial. We prefer it red, but it is sometimes tinged with white. You have been correctly informed when you were told it was a most important point in a Hambrogh. To that breed a red deaf ear is a disqualification; it must be perfectly white.

CRYSTAL PALACE POULTRY SHOW.—Owing to the late hour at which some of the classes were judged our reporters were obliged to leave before a few of the cups were awarded. We now give a list of those omitted in our report. Mr. H. J. Goifrey's Black Cochin took the cup in *Any other variety*. For the best young *Pouter cock*, Mr. Volekinn. *Carriers, any other colour*, Mr. Deane. Mr. Fulton won two cups—for *Blue Pied Pouter hens*, and the other for young *Barbs*. *Any other variety*, Mr. Wallace. For the best collection of *Short-faced Tumblers*, Mr. Ford. The third prize for *Black Bantams* was awarded to Mr. E. C. Inbridge; and Mr. J. Howes again exhibited a pair of his curious White Poking Bantams. Some exhibitors appear to remember the Impression, as the Show closed on Saturday, their birds were packed and sent away the same evening. The Commi tee were certain if they sent the birds away that night they would be kept at the railway station the whole of Sunday. The birds were therefore despatched on Monday, and every one was out of the Palace before 5 P.M. on Monday, and they should have reached their owners not later than Tuesday.

YORK POULTRY SHOW.—Mr. H. Andrews informs us that the first prize in the Felling class was won by his Dark Brahmas.

LA FLECHE HENS AT BIRMINGHAM.—We have received from our reporter at Birmingham a note, in which he says that he has not the slightest reason to doubt the correctness of the statement by the Hon. W. C. Fitzwilliam last week, as to the second-prize pair of La Fleche hens. He repeats, however, and thanks even Mr. Fitzwilliam will admit, that the appearance of the birds, on which his remark was founded, was precisely as stated, and was remarked upon by many, and if the strain had not been recently crossed by being run into the possession of the exhibitor, the pen must be regarded as neither of the uncommon nor, but very remarkable cases of inversion, or reversion to one of the races from which there is no doubt the La Fleche originally sprang. He

thanks Mr. Fitzwilliam for the gentlemanly tone of his note, which he is not willing to leave altogether unnoticed.

TAIL OF GOLD-PENCILLED HAMBROGH (*West of England Subscriber*).—A black tail is a disqualification in a Pencilled Hambrogh cock. The loss of a sickle is a great disadvantage, as it opens the door to suspicion.

COCHIN COCKEREL (*R. Crofton*).—Apply to some one who advertises, and do not buy until you have seen the bird.

MOTH IN SEAL SKIN (*Idem*).—Beat it, sprinkle camphor dust among the fur and hang in a warm dry place. When no insects are left keep the skin closely rolled in brown paper, several times enveloping it so that no moth can get to the skin, and keep it in a very dry place.

PIGEONS AT THE BIRMINGHAM SHOW.—Mr. Fulton writes to us that his Carrier Pigeons were neither trimmed nor oiled.

CARRIERS AT THE CRYSTAL PALACE (*An Exhibitor*).—We cannot insert your communication; it is, with little exception, at variance with the opinions of some of the best judges.

POUTER (*T. E. F.*).—The bird you describe is not an exhibition bird, it is too small, and merely is not usually a prize colour.

ENGLISH AND FOREIGN OWLS (*O. C.*).—We have often said that there is the same difference between English Owls and foreign or African Owls as between Long-faced and Short-toed Tumblers. The latter are delicate, small, fragile, and very tender. The fact of African Owls being bred in England does not make them English Owls. Barbs have for centuries been bred in England, yet they are called Barbs or Barbary Pigeons, because they originally came from that country. Although English Owls are more generally either powder blue or silver, yet there are white, black, or even yellow sometimes to be met with, and white with black tails.

HONEY INSIPID (*I. O. J.*).—If the so-called honey consists either wholly or in great part of sugar fed to the bees in the form of syrup, it would account for its insipidity. The character and taste of simple syrup is undoubtedly altered by being stored by bees in their combs, but it is not so full-flavoured as natural honey. The proportions of sugar and honey could only be ascertained by analysis.

REMOVING STOCKS OF BEES (*C.*).—We do not think you will find much difficulty in safely removing your bees domiciled in Woodbury hives to some distance by rail at this season. All that is necessary is to insure ventilation by covering the entrances and central apertures with perforated zinc, and to take care that the hives are carefully handled. A mild day should also, if possible, be selected for the removal.

METEOROLOGICAL OBSERVATIONS
In the Suburbs of London for the week ending December 20th.

DATE	BAROMETRICAL		THERMOMETER.				Wind.	Rain
	Max.	Min.	Air.		Earth.			
			Max.	Min.	1 ft.	2 ft.		
Wed. . . 14	29.255	29.040	58	35	46	43	S.	.29
Thurs. . 15	29.511	29.438	48	37	46	43	S.	.58
Fri. . . . 16	29.798	29.746	44	37	46	43	S.E.	.24
Sat. . . . 17	30.033	29.002	45	27	45	42	N.	.00
Sun. . . . 18	31.025	29.955	51	49	43	42	W.	.00
Mon. . . 19	29.879	29.515	51	35	43	43	W.	.08
Tues. . . 20	29.571	29.515	53	29	46	43	N.W.	.00
Mean..	29.714	29.587	49.86	34.71	45.43	42.71	..	1.10

- 14.—Showery; heavy showers; clear, starlight.
- 15.—Cloudy but fine; densely overcast; rain.
- 16.—Foggy, very damp; densely overcast; overcast.
- 17.—Densely overcast; clear and fine; starlight.
- 18.—Densely overcast; overcast; densely overcast.
- 19.—Densely overcast; overcast; rain at night.
- 20.—Fine but cloudy; fine; densely overcast.

COVENT GARDEN MARKET.—DECEMBER 21.

THERE has been a trifling advance in some descriptions of goods, but generally speaking much dullness prevails, and the great bulk of Apples and Peas being inferior in size and quality, the market is very heavy. Oranges from Malta and the Azores are much improved. Potato supplies are heavy, both by rail and coastwise. Quotations for vegetables are the same as last week.

FRUIT.

	s.	d.	s.	d.		s.	d.	s.	d.
Apples, 4 sieve	1	0	2	0	Mulberries, lb.	0	0	10	0
Apples, doz.	0	0	0	0	Nettles, doz.	0	0	0	0
Apples, lb.	0	0	0	0	Oranges, 100	6	0	10	0
Chestnuts, bushel	10	0	18	0	Peaches, doz.	0	0	0	0
Currants, 3 sieve	0	0	0	0	Pears, kitchen doz.	1	0	2	0
Black, doz.	0	0	0	0	dessert, doz.	1	0	5	0
Blue, doz.	0	0	0	0	Pine Apples, lb.	3	0	5	0
Elberts, lb.	0	0	2	0	Plums, 4 sieve	1	6	3	0
Colts, lb.	2	0	2	6	Quinces, doz.	0	0	0	0
Gooseberries, quart	0	0	0	0	Raspberries, lb.	0	0	0	0
Grapes, Hothouse, lb.	4	0	8	0	Strawberries, lb.	0	0	0	0
Lemons, each 100	6	0	10	0	Walnuts, bushel	10	0	15	0
Melons, each	1	0	4	0	do., 100	1	0	2	0

POULTRY MARKET.—DECEMBER 21.

THE near approach of Christmas, and the constant fluctuations of prices at this time, render any quotations impossible. We can only say that at the time of our going to press prices were high and well maintained, and that the absence of French supplies was sensibly felt. We expect during the week that prices will be well maintained.

WEEKLY CALENDAR.

Day of Month	Day of Week	DEC. 29, 1870—JAN. 4, 1871.	Average Temperature near London.			Rain in last 43 years.	Sun Rises.		Sun Sets.		Moon Rises.		Moon Sets.		Moon's Age.	Clock before Sun.	Day of Year.	
			Day.	Night.	Mean.	Days.	m.	h.	m.	h.	m.	h.	m.	h.	Days.	m.	s.	
29	TH		43.9	33.0	38.5	21	9	48	58	3	3	0	15	47	0	2	18	363
30	F		44.4	31.7	38.1	17	9	8	57	3	4	0	15	47	0	3	47	374
31	S		43.0	32.4	38.2	15	9	8	53	3	3	0	22	1	9	3	16	375
1	SUN	SUNDAY AFTER CHRISTMAS.	43.0	30.3	34.6	12	8	8	0	4	6	1	28	2	10	3	45	1
2	M		41.9	28.9	35.4	17	8	8	1	4	27	1	34	3	11	4	13	2
3	TU		42.6	31.0	35.3	19	8	8	2	4	52	1	40	4	12	4	41	3
4	W		42.2	28.6	35.4	17	8	8	3	4	22	2	45	5	13	5	8	4

From observations taken near London during the last forty-three years, the average day temperature of the week is 43.1°, and its night temperature 31.7°. The greatest heat was 58°, on the 24th, 1853; and the lowest cold 11° below zero, on the 4th, 1867. The greatest fall of rain was 0.86 inch.

NAMING FRUITS.



BOTANISTS, in ascertaining the names of plants and flowers, proceed on the principles of a systematic science. Botany has so arranged and classified all her subjects in their minutest order, that by careful study and observation we may trace out for ourselves the correct name of any which may be brought before us, whether we may happen to have seen the plant previously or not. There are the normal conditions of plants and flowers.

the genera and species that botany tells us of, which are typical and do not vary. These, when once seen and described, can be at any future time recognised. It requires study—profound study, no doubt—but it may be and is accomplished. With the varieties of species there is far more difficulty, and there are few amongst us who will either undertake to name, or expect anyone to know, the given names of mere varieties of either plants or flowers. The Editors of our horticultural journals, who seem to know almost everything, do not attempt much with varieties, excepting in the case of a few easily-defined forms.

Pomologists, in naming fruits, have but little to guide them. There is no system yet evolved which has reduced fruits to an order by which their correct names may be ascertained. Pomology is a science, and a most intricate and difficult science, without doubt. It is a science, however, without order, or with but little. It is a science of very close observation and much varied experience—a science, the various bearings of which are much better understood than easy to explain—a science, indeed, the whole superstructure of which each one has to erect for himself by close observation, acquaintance, and hard study. There is no royal road to learning it; there is no way of becoming acquainted with fruits or of knowing them, excepting by seeing them, tasting them, examining, describing, and comparing them for oneself. It is only by the most lengthened and varied experience of each individual subject, close observation, and most retentive memory that pomologists are enabled to determine the names of fruits.

Numerous and excellent as are our works on fruits, there is none by the aid of which without previous acquaintance that we can ascertain the name of a single variety. The best work of the Horticultural Society was its "Catalogue of Fruits" out of perfect chaos. Mr. Thompson did an immense amount of good service by his classification of fruits, so far as it went, and his short descriptive notices of them. Dr. Hogg also, the leading pomologist of the present day, has done, and is doing, much to extend our knowledge of and acquaintance with fruits. His "Fruit Manual" is the very best guide we can have. We are also favoured in various ways by minutely descriptive notices, outlines of the fruits, and even coloured illustrations, and yet—look at them as we may, study, compare, commit the whole to memory if we can—without the previous acquaintance we can by no means determine the name of a single specimen. It is only by a work of years, by a long and patient study of fruits in all their varied

forms, under all their various circumstances and conditions, that one can gain a true knowledge of fruits and their correct names.

Take any one class of fruit; they are mere varieties the one of the other, each possessing its own peculiar and distinctive features and character it may be, but they are inconstant and subject to vary very much under altered conditions of soil, situation, &c. There are other varieties possessing nearly the same characteristics, which also vary so that the two seem to intermingle, and it is almost impossible to distinguish the one from the other—that is, supposing our observation is limited in extent. The varieties may be perfectly distinct and easily recognised, if grown under similar conditions, and when seen in quantity it is also a simple matter to distinguish. Take, as an example, of Apples, the well-known Blenheim Orange, and another Fearn's Pippin; no two Apples in what might be termed their normal condition could be much more distinct, and as we have them described they seem to possess no possible relationship, yet there are grown hundreds of bushels of Blenheim Oranges of the low flat form which it is most difficult to distinguish from Fearn's Pippin. The Blenheim Orange is at times small, flat, highly coloured, and dry; sometimes it is large, upright or conical, pale, and juicy. The two forms may be found in the same garden, even on the same tree. Sometimes it is the soil, sometimes the season, a little good or bad cultivation, the influence of the stock, or more or less vigour in one branch as compared with another, that will effect all this difference which one who observes alone can tell. There is no book which can afford this information. Given—a flat form of Blenheim Orange, if the observer has never seen the variety in that particular form before, there is no means at his command by which he can ascertain the name. It has simply to be arrived at by reasoning on previous observations and acquaintance, or by a reference to actual specimens. Reference to specimens assists greatly in determining, or rather in deciding, the correct names of fruits; yet if the variety is entirely new to us it is extremely hazardous to identify it by this means alone.

Fruits, however, have certain normal features which do not alter, or but little. In forming our acquaintance with fruits it is useful to mark these, and so have them well fixed on our minds.

There are other features which, being affected by cultivation and other circumstances, vary considerably; these must be taken into consideration as changeable. If we take Apples and Pears, for example, the parts of the fruit which are fixed in character, and which may be pretty well relied on as distinguishing marks, are the stalk and the eye; these, then, should always be preserved uninjured. The size of the fruit is affected by cultivation; the flavour and consistency by the same cause; the colour by exposure; and the shape is also at times altered, but more rarely. Some fruits are much more subject to variations than others, some are very uniform, such as the Golden Noble Apple, the one larger than the rest, but no other variation. There is, however, with most fruits some characteristic feature, some little peculiarity which may be noted, and

which serves as a mark for its recognition—as in the Keswick Codlin Apple, the peculiar sharp rib or angle down one side, not existing on all, but on three parts; or, in the Kerry Pippin Apple, the short slender stalk, and the little knob at one side, of its base; or in the Lemon Pippin, the shape of a Lemon, but not always or in every example. Or take the Hoary Morning, which is beautifully striped, with its thick coat of white bloom as if it had been out in some hoar frost, although this feature is at times altogether wanting; or Dumelow's Seedling with its beautiful transparent skin, its wide open eye, and acid flesh, and there is no mistaking it. Take also amongst Pears the Vicar of Winkfield. Who that has once had its peculiar twisted, squinting look—the eye looking one way and the stalk the other—pointed out to him, can again mistake it? Again, look at Knight's Monarch—round, with its short thick stalk, thick leathery skin, and the crimson shade beneath the russet; or Beurré d'Areberg with its stalk on one side, and the small eye frequently wanting entirely, like Winter Nelis in this only, entirely different in other respects. We know Beurré de Rance by its shape, eye, long stalk like a peg, and green flesh; Urbaniste by its pale green skin, its soft silky feel, and its small eye; Napoléon by its bright green colour and peculiar shape, as if it had been squeezed out by the pressure of one's hand. Nurserymen know their trees by the leaves and habit of growth better than by the fruit. Some varieties are very distinct. Joséphine de Malines Pear is easily known by its small, full, round buds and yellowish wood. The varieties of Penches are distinguished not so much by the fruits themselves as by the flowers and leaves, or the glands on the leaves, &c.; and so on.

We thus by close observation and long intimate acquaintance acquire a knowledge of the distinctive features and peculiarities of many fruits. We know some by one feature, some by another; some by taste, others by shape or form, and others again by a peculiar mark or colour. We know many, perhaps, without knowing why or being able to impart the same knowledge to others. Constant association, with keen observation, will make one an authority on fruits, whilst no amount of study without association will do so.

The naming of fruits is no light task therefore; it is a special acquirement to be able to do so to any extent. There are many who can tell the names of the few he may himself cultivate, but in general a knowledge of the names of fruits is necessarily very limited. We had a Robert Thompson and we have a Dr. Hogg, but who is there besides? We have fruit-cultivators in plenty, but where are our fruit-nomenclators, if we except the worthy Doctor? Seeing that it is only by acquaintance, by a reference to true examples of each variety, that a knowledge of fruit can be acquired, it is most important that the Royal Horticultural Society should still maintain its splendid collection of fruits as examples. In the re-arrangement of the garden I hope that this point will receive due attention. It is the most important function of the Society to keep up a correct fruit-nomenclature throughout the country.

The editors of our horticultural journals deserve much credit for their persistent endeavours to correct the names of fruit. Every week we see a long list of names given: what a time it must occupy! what a patience is required to wade through basket after basket of fruits, many of them possessing no characteristic feature! Senders can surely have little idea of the labour required and the time to name forty or fifty sorts of fruit. It is expecting too much of good nature. Having had some experience of work of this sort I speak without restraint. Senders of fruit to be named should bear in mind that the namer has no knowledge of the circumstance under which the fruit has been grown to guide him, so that mistakes will frequently occur. The specimens selected to be sent should be as characteristic of the whole bulk as possible, neither too large nor too small, and if two distinct characters are found some of each should be sent. With Apples and Pears the stalks and eyes are required, and sometimes the leaves; with Peaches the flowers and leaves; with Grapes a bunch and leaves, and the more of any variety sent the easier it is to determine the name. It is altogether absurd to suppose that anyone is capable of naming correctly small and deformed fruits. The greatest authority on fruits after all only knows a few well-defined forms in the great and extensive family of fruits. There are hundreds of fruits, especially such as Apples, Strawberries, &c., throughout the country which have no recognised names. In one locality they are called by one name, and in another something else. To this each year are added seedlings more or less distinct, all multiplying and confusing the already too numerous

varieties of fruits, and making it more and more difficult to give the name of any with certainty.—B.

THE OUT-DOOR CULTURE OF TEA ROSES.

MR. KENT (see pages 487 and 488), is blessed, for he can grow his favourites in the sunny south without winter protection, nothing more than a south wall; we in more northern latitudes are differently situated, and to leave Tea Roses without protection would be fatal—south wall or not. He has given his version, let me trouble you with mine.

During winter the bed or beds that are to hold your favourites must be prepared; any soil will not do. The best plan is to make entirely new beds annually to the depth of 2 feet, using good strong loam (sods), and rotten cow dung, with a little sand to keep it open. My plants are always potted early in November, and placed in a cold frame till January, when they are brought into a little heat. They flower early—about the end of March. After flowering give them rest; in the middle of April plant in the beds, and you will have flowers to your heart's content during the summer and autumn.

With me all the varieties Mr. Kent has named are good, and by adopting the course I pursue, even the dwarf Boule d'Or will blossom beautifully, but is always best in the bud. Gloire de Dijon we all know. A Henriette Christophe, Montplaisir, Madame Margottin, Solfaterre, Madame Bravy, Madame Willermoz, L'Enfant Trouvé, and the best, Maréchal Niel—these I cannot speak too highly of. Solfaterre is a Noisette—indeed, Noisettes mixed with the Teas do admirably together, and they being hardy will not require lifting.

In the case of Tea Roses as standards, it is always safest to lift them and plant at the foot of a wall pretty thickly, where they can have a mat thrown over their heads in severe weather, planting where they are to stand, quite at the end of March.

Those who grow the Tea Rose must not be afraid of trouble, constant attention is needed winter and summer. Keep your pruning-knife in your pocket, unless it is to take off the tops that are browned—no more. They will flower down to the tips, and in many varieties they will by autumn form creeping Roses covered with bloom.—ROSA ODORATA.

A FEW SELECT VINES.

IN writing these lines I address myself not so much to the professional gardener as to the amateur who may be desirous to grow a few good varieties of Grapes, but who, from the great number of kinds now cultivated, is unable to select for himself. The varieties enumerated below are those which will do in ainery containing plants or in a greenhouse, but whatever plants may be grown with the Vines up to the time of the Grapes commencing to colour they should at that stage be taken out. I would lay particular stress on this, as I have proved that Grapes, to be well grown and of good flavour, and to hang on the Vines, should have the house to themselves after the last swelling, and this more especially applies to the late varieties.

To those who contemplate building I would say, Build two small houses rather than one large one, because you will then always have a house to keep plants in. Thus, in the case of the early house, you may have plants in it from the end of September to the middle of June; as the heat becomes too great for bedding plants they can be taken to the late house. The Vines in the early house being pruned, cleaned, and tied down in November, they are ready for starting in the first week of January, having three weeks previously covered the border with stable dung and leaves to excite the roots into action. I am supposing the border to be outside. I find this a very useful house for propagating bedding plants, and growing Fuchsias, Azaleas, &c., till they flower. In September, most of the Grapes being cut, it is ready for the reception of Azaleas, Camellias, &c., which till then have been out of doors, but which should be under cover before the heavy autumn rains set in. Vines grown in the same house as plants require dressing twice with soft soap 4 ozs., white soap 4 ozs., and sulphur 4 ozs., to destroy all eggs of insects, it being impossible to keep them clean, and Azaleas are about the worst plants to grow along with Vines, the thrips being so hard to kill. In a future paper I will describe the kind of house best adapted for growing a large number of miscellaneous plants together with Vines.

In giving a short list of good useful Vines, I confine myself

to my own experience here, as, perhaps, those varieties which do well here may not succeed farther north. The Vines being started on New Year's-day, I cut in the first week of July good bunches of Grizzly Frontignan, a Grape of delicious flavour, and ready for table the first. The colour is objected to by many, it being neither white nor black, but red. I consider it superior to the White Frontignan. It is a good cropper, but gains nothing by keeping, as, though I cut every month up to the first week in September, those bunches cut from the same Vine in July were the best. The bunch is long and tapering, but the Grape is small both in berry and bunch. Royal Muscadine, a white Grape, is ready about the same time as the preceding, but requires to hang a few weeks. It is likewise a good early Grape, and I shall also have to speak of it in giving my late list. It is a sure fruiter, but, like the Grizzly Frontignan, small. Buckland Sweetwater is a very fine useful Grape of good flavour, also a good bearer. Foster's White Seedling is a first-class Grape, and is larger than any of the preceding; it is also a good keeper. I likewise tried the Muscat of Alexandria, but found it would not do, requiring more heat to attain perfection than I could give it, as well as to hang too long—say till November or December—while the greenhouse plants are taken in in September. Black Hamburg, a good Grape, of excellent flavour, a fine cropper, and large in the bunch and berry, with me gives way to Pope's Hamburg (Frankenthal), a thin-skinned Grape, better-flavoured than the Black Hamburg, and as good for keeping. To show that it is a good bearer I would say that on taking charge of the Vines here in 1868, I found a fine Vine, which had been planted about fifteen years, in a very poor condition; however, I encouraged it in every way possible to make plenty of wood, and a Mt Hill Hamburg next to it having died, I decided on running up a rod of Pope's Hamburg, and well it has repaid me for the room. This year I cut from it twenty-four bunches of excellent Grapes, the least weighing a pound, and I might have had more bunches had I thought proper.

Thus, for an early house, we have Grizzly Frontignan at the warm end, Buckland Sweetwater, or Foster's White Seedling, Royal Muscadine, Black Hamburg, and Pope's Hamburg; and rather than have more varieties of black Grapes in the early house I would prefer two Vines each of the Hamburg.

In the late house, in which it may not be convenient to keep up a very strong heat, I would have Royal Muscadine, a good keeper. I have now, December 10th, good bunches as fresh in the berry as in September, and the flavour is excellent. Foster's White Seedling is also good, and I would have Trencham Black in addition to Pope's and Black Hamburg, for up to Christmas there is no black Grape equal to the Hamburg. On December 10th I cut excellent examples of Pope's Hamburg. These varieties should be planted at the coolest end of the house. West's St. Peter's, a rather small Grape, but good, is the next for cutting for table. This is very prolific, and a good keeper. I have the misfortune to have a Barbarossa [Gros Guilanme] in my late house—I say misfortune, because, although a fine Grape, it requires heat. With me it is small, both in berry and bunch, but will follow West's St. Peter's; then comes Lady Downe's, and lastly Alicante. I have included the last two, as, though they require rather more heat than the rest, they can still be grown for a crop. I would add, that though this is a small list, still the varieties I have named are sufficient to meet the requirements of those for whom this paper is written.—STEPHEN CASTLE, *Bent Hill Gardens, Prestwick.*

KALES OR BORECOLES.

YOUR able papers of 1862 on the subject of Borecoles have not borne that fruit which might have been anticipated, as will be seen from the results of experiments which I carried out during the last two seasons.

ASPARAGUS KALE.—From fourteen different seed warehouses, embracing the leading wholesale and retail firms, I purchased parcels of "Asparagus Borecole." In four instances Couve Tronchuda was supplied, in five instances Jerusalem Kale; in three cases Buda Kale was given, in one instance Chou de Milan, and in another Ragged Jacks.

RAGGED JACKS.—Under this name in two cases I received Jerusalem Kale, in another a coarse-growing purple Kale, and in a fourth instance Chou de Milan. In the remaining instances I received the true Ragged Jacks.

BUDA KALE.—For this in four instances I received Jerusalem Kale, in one instance Couve Tronchuda, and in the remaining instances it was true.

DELAWARE KALE.—In eight cases I was supplied with Jerusalem Kale for this, and in one instance with Buda Kale, but in no instance with a variety to represent a distinct Kale.

JERUSALEM KALE.—In five cases I received what Mr. Cattell, of Westerham, calls Purple Jerusalem, in one case I had the Purple Dwarf Curled Kale; the remainder were the Green Curled Jerusalem.

LAPLAND OR SIBERIAN KALE.—In one case I received Egyptian, in another Buda, and in a third Dwarf Purple Curled Kale.

CHOU DE MILAN.—There was a wonderful unanimity in this. Only in one instance did I get a different thing, and that was a green variety of Couve Tronchuda.

RUSSIAN KALE was a mixture of Buda and Jerusalem Kales.

EGYPTIAN KALE.—Very few offered this, and these seemed to be of one mind.

MILLER'S WINTER KALE proved to be Egyptian.

VICTORIA MARROW KALE turned out to be Couve Tronchuda.

CAMBERWELL KALE proved to be Ragged Jacks.

COTTAGERS' KALE.—There was no diversity of opinion as to this.

ACME KALE proved to be Jerusalem.

BUCKMAN'S HARDY WINTER GREENS.—This differs from anything I grew, and seems a sturdy plant, which is likely to stand the severest winters, and gives plenty of green food, but I can say nothing of its cooking qualities, not having tasted it yet.

CURLY GREENS, GERMAN GREENS, SCOTCH KALE.—There appears to be a great disposition here to multiply names. I had Prince of Wales, Tall Green Curled, Feathered Scotch, Abergeldie, Handsworth, Superb Tall, Superb Parsley Curled, Williams's Matchless, Pontefract Green Curled, Tynningham Green Curled, Williams's Dwarf Green Curled, Veitch's Dwarf Late Curled, Dwarf Curled Canadian, Moss Curled, Stuart and Mein's Extra Curled, Dickson's Imperial Dwarf Curled, &c. These were simply variations in the selection. Some few differ in the shade of green; but none of them possessed that pro character which long ago I was taught to believe that the fairies rode upon in Ireland, and to my personal knowledge and experience the lads and lasses in Scotland go after, on Hallowe'en, to see what luck they will have in a husband or a wife.

Having pointed out the inconsistencies which exist amongst those who sell Kale seeds, I hope you will do something, either in the way of illustrations, or such full explicit descriptions affixed to the names as will give the seedsmen a chance of starting fairly. I need not say how unsatisfactory it is to send to your seedsmen for one thing, and receive something the opposite of what you want. I might touch upon other Kales, such as the Lanthis, Flanders, Thousand-headed, Jersey, Brown, Palm Kale, and many others, but these are not so prominent in our seedsmen's catalogues, nor such confusion in the names, so that we may leave them to be dealt with in a descriptive list of Kales. Those I have treated of are what might be termed the domestic Kales, and it is desirable, for the sake of the gardening community, seedsmen should have some unanimity touching the application of their names.—**AMATEUR.**

POTATO SETS.

ON page 389 of your Journal, "CALGARIA" gives his experience in planting Potatoes, and asks for that of some of your correspondents. I will give you mine during the past season.

I bought 6 lbs. of the Early Rose Potato from one of the London nurserymen, numbering twenty-four Potatoes. Twelve of them I cut into sets; I planted them 2 feet from row to row, and 1 foot from set to set. The remaining twelve I planted whole, in a row 2 feet from the others. In the autumn the produce from the sets was one bushel, from those I planted whole not quite half a bushel; so that had I cut the whole of them, the produce would have been two bushels, instead of one bushel and a half.—**T. C. W., Royston.**

SETTING OF GRAPES.

MANY papers have been written on this subject, and very opposite opinions expressed. I have seen a dry atmosphere, a damp atmosphere, a high temperature, and plenty of air, all recommended in turn to insure Grapes setting well. As is known to many of your readers, I have been crossing Grapes rather extensively the last few years, and have, I think, collected a few facts.

The first deduction I have made is that no treatment can be

expected to give the desired result to a mixed collection of bad-setting Grapes, because bad setting springs from various causes. To illustrate this, take two well-known Grapes—Black Morocco and Canon Hall Muscat, two of the worst-setting Grapes known. The cause of Black Morocco not setting is that the anthers curl back at the moment the flower opens, and it is a mere chance if it is self-impregnated; but if you apply pollen artificially every berry will set. With the Canon Hall Muscat the pistil appears in fault, the end always seems wet; and even the pollen of other Grapes applied to it artificially has not with me always insured its setting. Now in this case one can imagine a high temperature beneficial. Then, again, I have seen Trentham Black badly set in a warm house, and every bunch perfect in a cold orchard house.

I have lately come to the conclusion that no treatment can be the very best for each individual of a mixed collection of Vines. Perhaps this is the reason why we find good gardeners famous for the cultivation of particular kinds of Grapes, one for his Muscats, another for his Hamburgs, &c. Now where great success has been attained, how interesting it would be if we could learn the treatment in each case! What light might not be thrown on the peculiarities of each variety! With me Mrs. Pince's Muscat formed beautiful bunches, and set almost every berry. It had plenty of air on sunny days, a good heat, and the flowers were gently touched with a brush nearly as thick as a wrist, made of camel's hair. The same treatment gave me splendid bunches of my favourite Grape, Muscat Hamburg, weighing from 5 to 6 lbs., yet in the same house Trentham Black set badly. I think Mrs. Pince will yet be a favourite as a late-keeping Grape. It improves in flavour by hanging, and in a damp house full of Geraniums, where even Lady Downe's rots badly, it is as perfect in appearance as it was three months ago.

Another fact, I think, is proved by my experiments; it is that every crossed seedling shows by its foliage it is crossed; and I think I have also proved that to cross Vines is not quite so easy as many people think. I look upon Golden Champion as being an uncrossed seedling from Canon Hall Muscat, because no one can distinguish them by growth or foliage; and from the great similarity in everything but colour, I should say the White Lady Downe's was also an uncrossed seedling of the black Lady Downe's. It is well known colour in seedling Grapes is quite accidental, white ones bringing black ones, and *vice versa*.—J. R. PEARSON, *Chilwell*.

ELSHAM HALL, LINCOLNSHIRE.

THIS, the seat of Colonel Astley, possesses amongst many others the advantages of a double access by rail. From the Brigg station it is approached by the uninteresting North Road, which, skirting the "Cars"—rich low-lying alluvial flats—for some three miles, branches through the park, and by an avenue of young Elms brings you circuitously past the dairies and aviaries to the Hall. From Barnetby station on the east, distant some two miles, one is brought through the village of Elsham, which nestles in a sheltered corner on the southern declivity of the Wolds. All here, save the ancient church (shortly, it is to be hoped, to participate in the general renovation), speaks of prosperity and comfort; the substantial houses of wealthy farmers, and the cottages of the labourers with their trim gardens, kept with a neatness and pride which does them credit, indicate the interest of a generous squire. Either route brings you to the Hall door. Looking to the north there is an expanse of grass, covered in spring time with Crocuses, Snowdrops, and Daffodils, backed by a sheltering wood of splendid Sycamores, Walnuts, Scotch Firs (one remarkable for magnitude and beauty), Oaks, and Elms, in which the rooks, which, doubtless, supplied the motto of the ancient Corbet family, "*Deus pascit corcos*," have for centuries reared their young. The mansion belongs to that period of architecture when houses were built to live in and not to look at. It is remarkable for hospitality without humbug, as being one of the few country houses where they brew their own beer, and one of the fewer still where they brew it good.

We pass on to the gardens. On the east and south of the mansion there is a broad expanse of beautifully-kept lawn, relieved here and there with forest trees and the deep foliage of the Yew, separated from that on the north by an caken rustic fence, profusely covered with creepers, extending from the north-east angle of the house to the orangery. The whole of the lawn is separated from the park by a semicircular sunk

fence, so that looking from the drawing-room windows towards the east the eye wanders over an undulating park, stretching far along the southern face of the Wolds, fringed entirely with woods, and dotted here and there with venerable Ash and other forest trees. In the foreground is a new geometrical garden, designed and laid out with great skill, and planted with equal taste, by Mr. Gardner, who takes as much interest as his master in all the improvements and new beauties of the place. The individual beds are beyond a brief description; suffice it to say they encircle an elegant fountain, amply supplied with the brightest water from the northern hills. Looking to the south, a mass of huge Sycamore trees conceals the stables, kennels, home-farm buildings, workshops, &c., and fringes the one side of a small lake; the opposite is adorned with a long terrace, decked with variegated Ivies, Jasmine, Cetonasters, Honeysuckles, and Roses, which droop to the water's edge, whilst from scores of vases huge Scarlet Geraniums seemed to pour a blaze of light. This is one of the prettiest views I know. Standing on the lawn the eye is carried down the lake; on the left hand a gentle slope of grass dotted with the Sycamores, on the right the long line of terraced flowers, whilst an island at the end partially intercepts the view, which, resting awhile on a second lake, dies away in the distant park.

To reach the kitchen garden we cross the little brook at the head of the lake, and skirt its western side along a trim gravel path leading to a garden embowered in trees, open only to the south-east—a large grass plot with beds of varied shape, surrounded by a gravel path; a comfortable summer-house at the more northern end, a rustic bridge at the other. In this garden, beyond everything being very good of its kind, there was nothing remarkable, save one circular bed, the centre being Palma Christi, 7 feet high, surrounded by *Canna grandis*, this again by *Veronica Andersoni variegata*, edged with Prince of Orange Calceolaria, forming altogether a dome of foliage and flowers which I have not seen surpassed.

Crossing the bridge, which partly forms a boathouse, we stand upon the terrace, some 150 yards in length. Here the walk diverges right and left. On the left is the long terrace on the lake, in the centre a lawn cut into suitable beds, filled with bedding plants and other flowers, perfect in vigour and harmony of colour; on the right the other path is flanked by a ribbon border, and a wall extending on one side of the kitchen garden covered with well-trained fruit trees—Figs and Pears. In the middle of this wall there is an arched stone gateway and a beautifully wrought-iron gate, corresponding well with the scrolls and wreaths of Roses remarkably well carved in Ancaster stone.

This brings us to the central walk of the kitchen garden opposite, to the right and left being the rows of houses, forcing-pits, frames, &c. This garden is nearly square, surrounded by walls—such walls! 15 feet high, 2½ feet thick, coped with Yorkshire flags 3½ feet wide and 4 inches thick. These walls are covered with fruit trees, well trained and in full bearing, the southern inside wall mostly with Peach trees, protected with one long length of frigi-dimo, and I quite envied the facility with which a man ascended a ladder, walked along the coping, and raised the protector. A wide south border is lightly cropped with early vegetables, which are yet further coaxed by means of "cloches," an invention of which Mr. Gardner certainly approves for particular purposes. The potting houses, fruit rooms, &c., are at the north side of a wall.

Against its opposite side leans, in melancholy decrepitude, the ancestral vinery; paint, putty, and wood seem to have long since struck work. The Vines appear to have been trained on the "anyhow" system, yet even here skill and attention have educated a fair crop of Grapes, despite constant drip and uncontrollable ventilation. What a change when we pass hence to the Peach house and new range of vineries! Perfect houses and perfect trees; wood of equal growth and vigour, short and well-ripened, full of those delightful triple buds. In bloom and in fruit I saw them equally beautiful. The new vineries, 90 feet long, heated by a tubular boiler, were erected by Gray, of Chelsea, in three compartments, and have outside and inside created borders, with a space outside and in, to be filled up as the Vines require it. As at Garston, the bottom of the border is level with the surface of the garden; total width 21 feet, 4 feet thick, with a fall of 15 inches. The Vines are but young, and look as well as possible. The forcing house, Melon and Cucumber houses, and a range of raised pits, all heated by one saddle boiler, were well occupied, and extremely clean and tidy. A new Mushroom house was being

erected, with very well-arranged cast-iron supports for the 1½-inch red deal floors and fronts, which, fitting into grooves and being moveable, afford great facility in cleaning and renewing. This arrangement, executed by Bevitt, of Pontefract, is well worth the attention of anyone; a trifling alteration would make them perfect. Forced vegetables, required in great quantity, are produced of excellent quality, whilst the main crops, skilfully attended to, grow to prodigious size in the rich humid soil of the garden, into which abundance of water is introduced by pipes communicating with the lake. I noticed particularly Cottagers' Kale, some 4 feet high, each large enough to satisfy half a dozen "chawbacons;" Cardoons in great perfection, which Mr. Gardner purposes to utilise in the shrubberies as winter foliage plants; and healthy rows of Ne Plus Ultra Peas, which (at the end of October) were as good to eat as they were to look at.

After all, I am nearly omitting the chief thing which made me write—the removal of some old fruit trees. It was desirable to widen the centre walk, and to do so it was necessary to transplant in November, 1868, some espalier Pears and Apples, which measured 33 inches in circumference, and extended their branches 14 yards. In 1869 they looked very sickly, in 1870 they bore an abundant crop, having quite recovered their removal. Mr. Gardner attributes his success to very carefully forking up the roots, plentiful mulching, and abundant water. The result should encourage all who need it to make the attempt to save such fine old trees, and forbid us to accept as impossible an operation we have never carefully tried to execute.—C. C. E.

MAIZE.

[The following paper, forwarded to Dr. Masters for presentation to the Royal Horticultural Society, was read at the General Meeting on the 7th inst., in illustration of the collection of Maize exhibited by the Rev. T. C. Bichaut.]

THIS collection of Maize exhibited has been formed from various sources, but mainly from a selection from the splendid varieties shown in the American section at the Paris Exhibition of 1867. As this was an unique occasion, and specimens from every known variety of a country having such a wide range of climate, and one where the plant is so generally cultivated, were present, this would, of itself, commend the collection to European notice. Since that time seeds from other parts of the world have been procured, and an exchange effected with Messrs. Vilmorin, of Paris, who have devoted considerable attention to the culture of Maize, the use of which is becoming very popular in France.

An experience of three very dissimilar seasons has been gained since 1867. A certain number of varieties have been discarded, either as too small, too coarse, or as ripening at too late a period of the season to make them generally serviceable. It was to be expected that the sorts which ripened the earliest would become most in demand, but there were other conditions to be fulfilled before Maize could be able to hold its ground against so many new and known vegetables. It was not so much a variety which should serve for cattle, or poultry, or even for grinding into flour, which was required, for such are now commonly imported more cheaply—at least so it seems at present—than they can be grown in our climate; but it was sought to popularise the manner of eating Maize so common in the States of America, and in other regions of the world (including even Southern Europe), as "green corn"—i. e., in a semi-ripened condition, when the grains had acquired the consistency and size of good Marrowfat Peas. The addition of a table vegetable of this delicious and nutritious nature—the food of millions of the human race—and yet, for want of experience of the sorts adapted to our climate, so strangely unappreciated here, seems of no inconsiderable importance, the more so as it ripened in the late autumn, reproducing then the best flavours of the early Pea and of the Asparagus. For this the ordinary yellow Maize is not suited, so that its culture becomes of little value. But the collection here exhibited claims not only to be the most complete which has probably ever been presented in Europe, but it also shows varieties which greatly excel the Maize known in this country and in France in size and in flavour, while they still fulfil the special conditions required in earliness. More than this, these ears are grown from seeds acclimated by three varied seasons in the Channel Islands, and are even immediately sprung from seeds of plants growing in the damp and sunless season of 1869, which plants were prostrated to the earth when at their fullest and most critical season of growth, on September 12th, under the weight of a hurricane of 55 lbs. pressure per square foot. The perfectly ripened specimens exhibited attest the vitality of Maize when treated with common care. Remarks on the different kinds will best be made as each is examined. A few observations must now be made on the

Uses of Maize.—It would be without interest here to speak of the numerous purposes to which this most valuable plant is put, when in a dried state, in tropical regions. The drought of past seasons shows the need of adding to our resources, if possible, whatever green fodder

can be grown. There are certain kinds of Maize better adapted by their growth than others to fulfil this object, being hardy and rapid in increase, and at the same time abounding in saccharine juices, which animals will devour greedily. Even the stalks when hard can be utilised by slicing them, so that there is really no waste. Mention having been made of these varieties in the French scientific journals, a pressing request was sent here for a large quantity of seed for Brittany, there to be cut down and used as forage during the drought.

Culture.—The seeds should be sown in common raising boxes during April—early in the month in the south, and later in the north of England. In the Channel Islands they were sown in boxes very early in April, and planted out three weeks after. These boxes should be placed in a cool viney, orchard house, or pit, and the plants hardened off before planting. This would be best in May, earlier or later according to the season or locality, which a short experience would decide. The risk of the young plants is common to other vegetables—that of suffering from spring frosts; a little protection would obviate all this. But this season Mr. Dancer, of Chiswick, we are told, sowed a quantity of Maize in the open ground in March. It was cut down by the frost, sprang up again from the root, and yielded a heavy crop.

By the end of July our Maize plants were already 7 feet high, and were then secured from high winds by stout stakes at intervals, and thin cords stretched between them, to which the rows were easily tied. Not being able to give waterings, which materially aid the growth of a plant which luxuriates in the rich alluvial valleys of tropical countries, we had planted in shallow trenches filled with manure, and 3 inches of soil above it. These trenches retained the casual showers, and were gradually earthed in, as for Celery. The manure kept the roots perfectly fresh, and two light waterings of liquid manure were given during the very dry summer. This attention is not greater than is always given to Peas and other vegetables. Failures are traceable to a neglect either of some, or even of all, of these means.

It is not quite so easy to ascertain the exact time to take the ears as "green corn" for the table. A day or two makes considerable change in their consistency. When as large and as hard as Marrowfat Peas, from twenty to thirty minutes boiling is enough. Serve with fresh butter to spread over them, and they are thus ready. All the uses made of Peas for soups and stews are common to green Maize. The ears can also be roasted before the fire. When dry, these fine white varieties would produce very pure flour for puddings, &c.

Maize, in our climate, requires five months to mature the seeds for sowing, being one month more than in California. Some sorts ripened here in August. The stalks reached to 10 feet, a height only excelled in rich tropical soils. Where several sprang from the same root, the ears ripened sooner. Experiments were made in hybridising, with some results, and also in mutilating the male panicle of flowers with a view to increase the size of the ear. After several generations of mutilated plants had been experimented upon, it was found that the ears were increased sensibly in size. The produce of seed was at the rate of ninety-five bushels the acre, gathered as it was, not from selected plants, but from numerous varieties, some being too small.

Remarks on the Varieties.—Nos. 1, 2, 3, and 4 are specimens of the best pure white Maize from Georgia. This is the most delicate for table use; ripened this season at the end of September, and is an early sort, and the most valuable in every respect. No. 4 of these has spiky grains, and is even whiter than the others.

No. 5, King Philip, from M. Vilmorin; considered a good kind in France.

Nos. 6, 7, and 8, are "Flint Corn," very much like that grown near Bordeaux, but superior. No. 6 of these is a free-growing and valuable table Maize.

Nos. 9 and 10 are "Pink Corn." The first of these is a remarkably fine specimen, and this variety is earlier than the pure white, is delicate in flavour, and more valuable than No. 10.

No. 11 is the Giant Red, the largest of all, excellent, and a mid-season sort.

No. 12 differs from this in having smooth grains.

No. 13, Jaune Gros, from Vilmorin. This is much grown in the Touraine, and is the cheapest of all, but rather too coarse.

No. 14, A striped yellow originally from Paa, and raised from seed from plants grown in Yorkshire. A hardy and valuable kind.

No. 15, True "Yellow Pop Corn," from America. A very excellent kind, prolific and early; will be very useful for forage also.

No. 16, Jaune d'Annonce, early, and good for grinding purposes.

No. 17, Improved Common Yellow, an excellent kind, raised here, and larger than the common one.

No. 18, A small, late, yellow Maize.

No. 19, A handsome and heavy spotted Maize, raised here this season in some quantity.

Nos. 20, 21, 22, 23, 24, and 25, are hybrids of various shades, easy to retain pure. An opinion as to the best would be valuable.

No. 26, A short corn; spiky.

No. 27, A new African Maize from Italy, very hardy and prolific, likely to be very useful.

No. 28, Handsome hybrid of this year—mid-season.)

No. 29, Darkest ear ever raised here.

No. 30, "Blue Corn," very difficult to ripen. One, more handsome, has disappeared from culture here; another has magnificent gold-striped leaves, with dark, hirsute stem,—equals the Japanese

Variegated Maize for gardens, and is 9 feet high. Of this valuable kind only a few seeds exist here, and no ear.

No. 31. Early White "Pop Corn." Dwarf, and carious, not being so profitable for a sweet meal as No. 15.

No. 32. Boston Ten-weeks Maize. It excels the French Ten-weeks somewhat, but both are too small.

No. 33. Small-seeded red. Curious, and difficult to ripen.

No. 34. A similar variety; generally of the present size.

No. 35. Large pale red.

It remains only to add, that seed for sowing can be obtained in gardens in warmer districts, and always from such places as the Channel Islands; while Maize, to be eaten green in the autumn, can be grown anywhere with common attention. The same may be said of its use for forage.—TH. C. BREHAUT, *Richmond House, Chertsey.*

ENTOMOLOGICAL SOCIETY'S MEETING.

The December meeting of this Society was held at Burlington House, the President, A. R. Wallace, Esq., being in the chair. Amongst the donations to the Society's library were the "Memoirs of the Society of Naturalists of Moscow," and other serial works.

Mr. Edward Saunders exhibited three species of Hemipterous insects new to the British fauna, *Salda arenicola*, from Bournemouth; *Plociomerus luridus*, from the New Forest; and *Hadrodema Pinastri*, from the neighbourhood of Reigate; also a series of continental species allied to *Strachia festiva*, in order to clear up the synonymy of that insect. Mr. Pascoe exhibited two new species of Longicorn Beetles from the Himalayas, collected by Captain Lang, forming two new genera. Mr. F. Smith exhibited two small species of Beetles new to the British list, collected by Mr. Champion—namely, *Culodera rubens*, from Lewisham; and *Baridius scolopaceus*, from the coast of Kent. Mr. Butler exhibited a very minute specimen of *Vanessa Urtice*; it was one of the second brood, and had the hind wings very dark coloured. Mr. Albert Muller exhibited a series of photographs of remarkable kinds of Galls, caused by different species of Rhodites and Cynips, chiefly upon Oaks in North America, which he had received from Mr. Passett, of Waterbury, U.S. Mr. Sydney Saunders exhibited a living specimen of the remarkable *Eresus Ctenizoides*, a very large Spider of a black velvety colour, with a flattened abdomen, which is surrounded by a bright red band. It is a native of Syra, in Greece, and feeds upon large Grasshoppers, but it had remained without eating since July last. Mr. F. Smith stated that the Grasshoppers in this country are attacked by a large silvery species of *Asilus*, which preys on them and carries them off.

The commencement of an elaborate memoir on the family Ephemeridae, or May Flies, by the Rev. A. E. Eaton, was read. The author has devoted much attention to the minute anatomical characters and transformations of these interesting insects, of which he has described 178 species, British and foreign, a great number of which are new to science.

SALES AT COTTAGE GARDEN SHOWS.

"HORTUS" would find it a good plan to announce to visitors at the cottage garden shows, before the prizes are distributed, that it is very important to the exhibitors to sell their produce, and for that purpose, immediately after the distribution of the prizes, the exhibitor will return to the tent, and gladly sell to anybody who will purchase. The plan is sometimes adopted of putting the value on a card. This is convenient, as, if the owner is away, the willing purchaser can write his name on the card.—THOMAS COX, *President of the Nutfield and Betchingly Cottage Gardeners' Show for 1870.*

I SUGGEST that the cottagers should affix the price of their commodities. Persons wishing to buy will see at once the price; then "first come, first serve."

Tea Rose Madame Levet (see page 487) is here, but I have not proved it.—W. F. RADCLIFFE, *Okeford Fitzpaine.*

PRUNING ORNAMENTAL TREES AND SHRUBS.

No. 7.

THE groups dividing flower gardens or pleasure grounds and parks, or those planted for shelter or other objects, afford scope for a display of trees and shrubs on the massing system quite as well as, or even better than a group to which access can be had from all sides.

Fig. 1 is a group of this kind planted as a division between the park and pleasure ground, which are separated from each other by iron fencing. *a*, Cupressus Lawsoniana, and the dots on the margin are of it and its varieties; *b*, Rhododendron ponticum; *c*, Deodar Cedar, on raised ground; *d*, Cotoneaster irigida; *e*, Ghent and English varieties of Azalea pontica; *f*, English Hollies (Ilex Aquifolium, and vars. femina, flava, and angustifolia); *g*, Berberis Aquifolium; *h*, Andromeda

floribunda; *i*, Cupressus Lawsoniana, with a few dotted on the margin; *j*, Menziesia polifolia alba; *k*, Berberis Darwini; *l*, Azaleas, with *A. amona* in front; *m*, Wellingtonia gigantea; *n*, Irish Yews; *o*, Pinus excelsa; *p*, Rhododendron, varieties; *q*, Portugal Laurel; *r*, Aucuba (old variety); *s*, Sweet Briar; *t*, Lime; where crossed filled in with Ligustrum ovalifolium, and yellow-berried Ivy; *u*, Black-leaved Laurustinus (Viburnum latifolium); *v*, Silver Fir (Picea pectinata); *w*, Purple Beech, filled in with Cobelian Laurel; *x*, Horse Chestnut, filled in with English Yew; *y*, Laburnum, filled in with Cotton-easter Simmondsi, and *C. microphylla*; *z*, Scarlet Thorns.

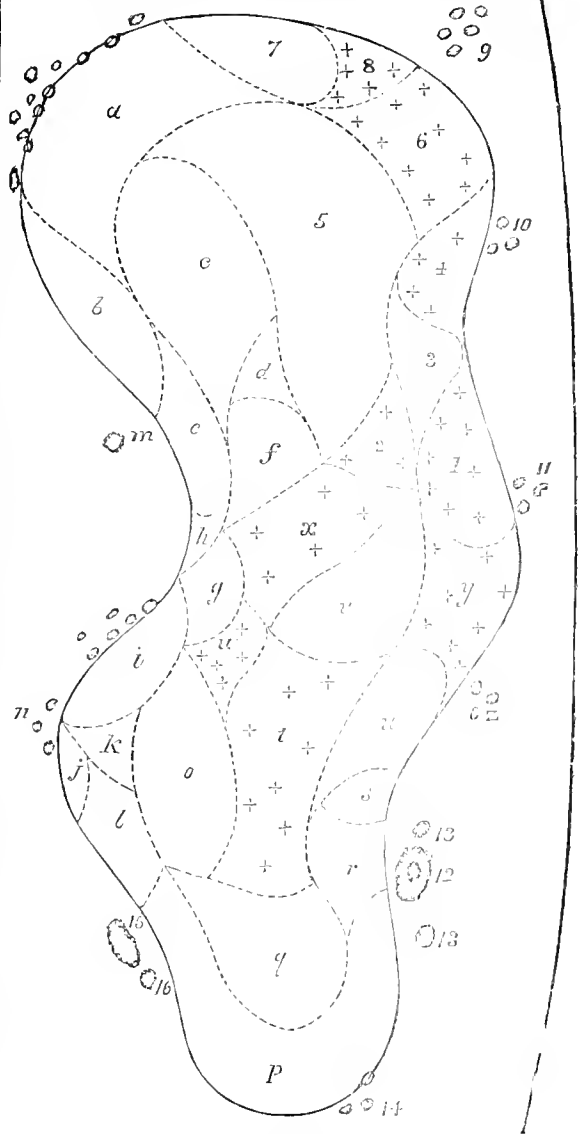

Fig. 1.

1, Lilacs, filled in with Berberis dulcis; 2, Mountain Ash, filled with Alexandrian Laurel (Ruscus racemosus); 3, Broom, of sorts; 4, Guelder Rose, with Mock Orange and Periwinkles intermixed; a few Vinca elegantissima on the margin; 5, Austrian Pine; 6, Scarlet Maple, filled in with common Laurel; 7, Hemlock Spruce; 8, Red-berried Elder, filled in with Berberis Aquifolium; 9, Pinus Cembra; 10, Pink Thorns; 11, White Thorns; 12, clump of Double Gorse; 13, Pampas Grass; 14, Variegated Hollies; 15, clump of Broad-leaved Holly, Ilex Hodginsi, and I. altacronsis; 16, Tritoma Uvavis.

Again, Groups in park scenery need not be of the species or varieties forming a genus, but may be variously planted, but still adhering to the massing system.

Fig. 2 I shall presume to be groups of this description. *a*, Sycamore, filled in with common Laurel; *b*, Austrian Pine; *c*, Spanish Chestnut, filled in with *Berberis Aquifolium*; *d*, Larch; *e*, Scotch Fir; *f*, Larch; *g*, Wych Elm, filled in with Evergreen Privet; *h*, Austrian Pine; *i*, Norway Maple, filled in with common Laurel; *j*, Turkey Oak, filled in with *Berberis Aquifolium*; *k*, Scotch Fir; *l*, Lime, filled in with common Laurel; *m*, Corsican Pine; *n*, Larch; *o*, Walnut, filled in with Evergreen Privet; *p*, Austrian Pine; *q*, English Oak, filled in with *Berberis Aquifolium*; *r*, White Thorn; *s*, Lombardy Poplar; *t*, Lilac; *u*, *Rhus Cotinus*; *v*, Laburnum; *w*, Mountain Ash; *x*, *Rhus typhina*; *y*, Horse Chestnut; *z*, Variegated Sycamore.

and then, though there may be considerable variation in the subjects and mode of placing them, there is but one result, a sameness in every part of the group or plantation.

As regards the dotting of trees singly at regular or irregular distances, as may be seen in almost all our parks, I have but little to say. There is something in having a well-wooded park or country to drive through and look at, but would anyone advise planting an open space on such a principle—if principle it be—as is presented in almost all our parks? It would be wrong to say a word against the fine trees to be found in our parks; but there are numbers possessed of no beauty, and to cut them out would improve the effect of those left, and allow of their broad distinctive features being seen to advantage,

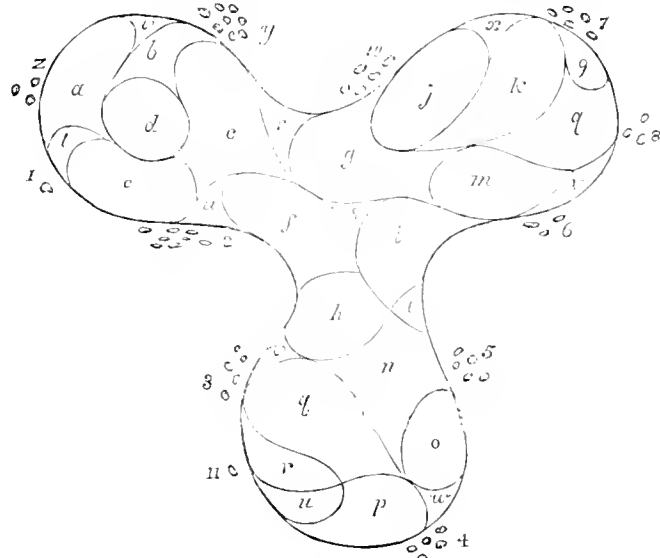

Fig. 2.

1, Purple-leaved Sycamore; 2, Scarlet Maple; 3, Lucombe Oak; 4, Purple Beech; 5, Lime; 6, Scarlet Oak; 7, Beech; 8, Scarlet Thorn; 9, Holly; 10, Exeter Elm; 11, Austrian Oak.

besides affording space for other and better subjects than those removed. This would destroy to a great extent the monotonous appearance of our park scenery, the new plantations being in masses, with open glades of grass of considerable but variable lengths and breadths.

In arranging shrubs in groups or shrubby borders there can be no question that of all the systems the massing is the best.

Suppose *fig. 3* to represent a shrubby border, which it is customary to plant in mixed order, then—*a*, Chinese Arbor-Vitæ; *b*, Gold-leaved Holly; *c*, *Rhododendron catawbiense*, vars.; *d*, *Phillyrea oleaefolia*; *e*, *Azalea pontica*, vars.; *f*, Guelder Rose; *g*, *Kalmia glauca*; *h*, *Berberis empetrifolia*; *i*, *Syringa* or Mock Orange, double-flowered; *j*, Green Hollies; *k*, *Deutzia gracilis*; *l*, *Aucuba femina limbata*; *m*, Scarlet Thorn; *n*, *Weigela rosea*, with the dotted space its variety *variegata nana*; *o*, *Berberis Darwinii*; *p*, Portugal Laurel; *q*, *Spiræa Thunbergi*; *r*, Scotch Laburnum, with Colchian Laurel; *s*, *Cydonia japonica*; *t*, Silver Holly; *u*, *Laurustinus*; *v*, Ribes, vars.; *w*, Lilacs; *x*, Double Gorse; *y*, *Kalmia*; *z*, Scarlet Rhododendron, and hardy Heaths.

1 and 8, *Kalmia latifolia*; 9 and 10, *Rhododendron*; 2 and 7, *Yucca recurva*; 3 and 6, *Andromeda floribunda*; 4, Tree Pæony; and 5, *Rhus glabra laciniata*.

Small groups on grass in pleasure grounds, it is scarcely necessary to say, should be of one species or of varieties of one species, but for effect those with distinct colours of foliage or flowers may be disposed in one part, and others of a different colour in another part.

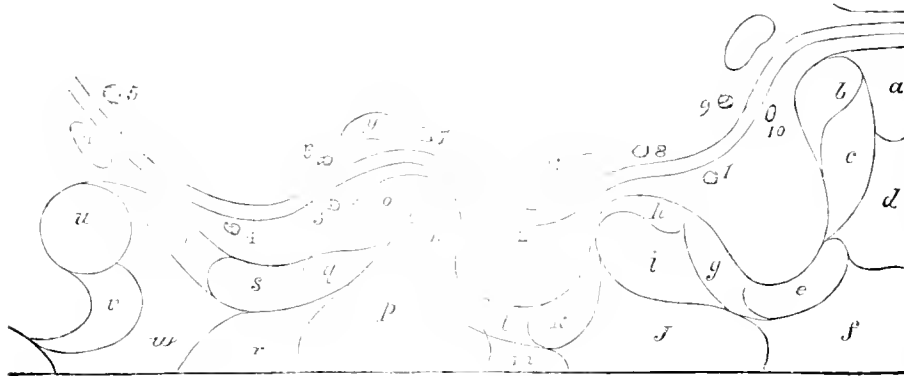

Fig. 3.

The preceding examples are not given as the best arrangements of trees and shrubs that can be made, but the sketches with which I have illustrated these papers, together with the remarks which I have made, may lead to more attention being directed to the subject, and to more imposing groups being planted, for I am convinced any departure from the present mixed confused distribution is an improvement.—G. ABBEY.

I think sufficient examples have been given to show the difference between the present mixed system and the but-little-practised massing one. I may be told that the massing system does not require a great variety of trees, or that I have cut up the groups into a great many fragments. My object has been to exhibit what a great variety the massing system is capable of producing even in one group; but will anyone tell me it will have that weary sameness of effect as if they were disposed at random? I believe each subject will appear in character, each exhibit a mass of foliage that will make it an object; but this is not the case when the subjects, however well chosen, are disposed in mixed order, the deciduous mixed with the evergreen, the object being to produce as much variety as possible;

THE ORIGIN OF SOILS.

If we dig down through the soil we come sooner or later to the solid rock. In many places the rock reaches the surface, or rises in cliffs, hills, or ridges far above it. The surface, or crust, of our globe, therefore, consists everywhere of a more or less solid mass of rock, overlaid by a covering—generally thin—of loose materials. The upper or outer part of these loose materials forms the soil.

The geologist has travelled over a great part of the earth's surface, has examined the nature of the rocks which everywhere repose beneath the soil, and has found them to vary in appear-

ance, in hardness, and in composition, in different countries and districts. In some places he has met with a sandstone, in other places a limestone, in others a slate or hardened rock of clay. But a careful comparison of all the kinds of rock he has observed has led him to the general conclusion that they are all either sandstones, limestones, or clays, of different degrees of hardness, or a mixture in different proportions of two or more of these kinds of matter.

When the loose covering of earth is removed from the surface of any of these rocks, and this surface is left exposed, summer and winter, to the action of the winds, rains, and frosts, it will be found gradually to crumble away. Such is the case even with many of those which, on account of their greater hardness, are employed as building stones, and which, in the walls of houses, are kept generally dry; how much more with such as are less hard, or lie beneath a covering of moist earth, and are continually exposed to the action of water. The natural crumbling of a naked rock thus gradually covers it with loose material, in which seeds fix themselves and vegetate, and which eventually form a soil. The soil thus produced partakes necessarily of the chemical character and composition of the rock on which it rests, and to the crumbling of which it owes its origin. If the rock be a sandstone, the soil is sandy; if a claystone, it is more or less stiff clay; if a limestone, it is more or less calcareous; and if the rock consist of any peculiar mixture of these three substances, a similar mixture is observed in the earthy matter into which it has crumbled.

Led by this observation, the geologist, after comparing the rocks of different countries with one another, compared next the soils of various districts with the rocks on which they immediately rest. The general result of this comparison has been, that in almost every country the soils have as close a resemblance to the rocks beneath them, as the loose earth derived from the crumbling of a rock before our eyes bears to the rock of which it lately formed a part. The conclusion, therefore, is irresistible, that soils, generally speaking, have been formed by the crumbling or decay of the solid rocks; that there was a time when these rocks were naked and without any covering of loose materials; and that the accumulation of soil has been the result of the natural detrition or slow wearing away of the solid crust of the globe.—T. JONES.—(*English Mechanic and World of Science*.)

CYCLAMEN PERSICUM CULTURE.

Your correspondent "W. Scott" (page 493), wishes for information respecting the early blooming of *Cyclamen persicum*. I sowed a packet of Wiggins's strain, on February 26th of the present year, in a seed-pan, which I plunged in a Cucumber frame then at work. The seedlings appeared by the end of March, were pricked out into pans as soon as large enough to handle, and placed again in the frame near the glass. They were potted-off singly into 60-sized pots by the end of May, were kept growing, and were shifted into 5-inch pots by the end of June; they were then placed in a cold pit and shaded from strong sun. By the middle of August I gave some of the largest another shift into 6 inch pots. They were kept in the cold pit until the end of October, when they were removed to a cool vinery, and were then showing plenty of bloom buds. On the 6th of December I introduced them into a vinery where the vines were just started, and they are now (December 26th), just ten months after sowing the seed, blooming beautifully, with flowers of several shades from white to red. I believe, had I kept them warmer in the autumn, the period would have been reduced to nine months.

The soil I used, which was always warmed before potting, was equal parts of half-rotted turf and well-decomposed cow dung, with a good mixture of silver sand. They were sprinkled overhead every morning with water from which the chill was taken.—H. HARRIS, *Naseby Woolleys*.

I FOLLOWED directions given in the Journal two years ago, and have been tolerably successful, though my gardening means and appliances are very limited. In March, 1869, I sowed a packet of Wiggins's seed. Out of the packet I had thirty plants. As soon as they showed their second leaf I repotted them, placing them three in a pot, in 3-inch pots. I kept them in fair bottom heat all through the summer, but did not renew in the autumn the dying heat of the frame they were in. They grew remarkably well, and came into blossom at Christmas, giving about five blossoms on each plant. I kept them

in their pots till May, when I turned them into the open ground of a spent cutting frame. There they continued till September, when I potted them three in a pot as before, in 6-inch pots, and the largest in separate 4-inch pots, and put them in gentle bottom heat. They are now coming into nice bloom. One is on my table as I write, a single plant with forty blossoms expanded and expanding. Some of the pots have between seventy and eighty blossoms coming on.

They would, I am sure, have blossomed much more freely the first year if I had kept them in constant bottom heat. They are flowers most valuable to those who like winter plants in sitting-rooms. They seem to suffer less from long continuance in hot rooms than any plant I know, except, perhaps, Palms, and even before they are in bloom their beautifully marbled leaves make them delightful objects. I had not much variety of colour in my packet of seed.—Q. Q.

LATE PEAS.

I FIND Mr. Castle (page 324) puts Veitch's Perfection in the wrong place. *Ne Plus Ultra* is the best suited for Prestwich, and is mostly grown as a late Pea, being more hardy than Veitch's Perfection. There is a late Pea called Swinton Cottage, a local name; it was raised by the late Dr. Robinson, of Swinton Park, is a late wrinkled Marrow, sweet-flavoured, and for a late or general crop is first-rate. I saw it myself after the frost in November, and tasted it before the frost, and the flavour was excellent. Many of the gardeners in this neighbourhood gather it when frost shows itself, and spread the pods out on a cellar flag, and by that means they last fully two weeks longer than if left out of doors. All the gardeners in this part try to have Peas as late as possible. I have seen them myself this season, late in November, until the frost cut them down.—SAMUEL PORTER, *Prestwich*.

PORTRAIT OF MR. RIVERS.

The following additional subscriptions have been received:—

	£	s.	d.
Dow, Mr. S. H., Clapton Nursery	1	1	0
Wheeler, Messrs. J. C. & Son, Gloucester	1	1	0
Wood & Ingram, Messrs., Nurserymen, Huntingdon	1	1	0

INTENSE COLD.—I forward you the readings of the thermometer during Friday, Saturday, and Sunday night, as it may be interesting to know how other districts were affected. On Friday night (Dec. 23rd), at 11 30, the thermometer marked 3°, or 29° of frost. At 6 A.M. on Saturday it was 5° below zero [?]; at 10 A.M., with a bright sun, it was down to 10°, or 22° of frost; at 12 it was 23°; at 2 P.M. it was 21°; at 5 P.M. it was down to 5°; at 8 it was down to 3°; at midnight it was 2°. At 6 o'clock on Christmas morning it was 3°; at 10 it was 6°; at 5 P.M. it was 13°; from which time till 9 o'clock on Monday morning the temperature gradually rose to 33°. The rime on Christmas morning on the trees was magnificent.—J. PLATT, *Gardener to Sir W. Folkes, Bart., Hillington, Norfolk*.

SOME PREDATORY INSECTS OF OUR GARDENS.—No. 1.

OCCASIONALLY in some of our country towns where, in spite of railways and telegraphs and other modern improvements, life is generally a little flat, amongst other expedients resorted to, somewhat to enliven matters, is the getting-up of small horticultural fêtes. These are usually carried out, partly under cover, partly *al fresco*, and a variety of mottos with floral embellishments may be seen on such occasions admirably arranged on the sides of the building or tent. There are certain inscriptions, however, which I have never seen put up, though they might be deserving the attention of the spectators. Suppose, in full view, were hung the proverb, "Live and let live," or this verse—

"Nought so vile upon the earth doth live,
But to the earth some special gift doth give."

In similar mottos a delicate hint could be conveyed to certain gardeners, who show a sort of spitefulness in the onslaughts they make upon the insect world around them. It is irritating—no question about that—to find that after much care and

attention, much head and hand work, an enemy, toiling insidiously at first, suddenly places his mark triumphantly upon our choice plants, flowers, or fruits, as much as to say, "That's mine, whether you like it or no!" But, still, I confess to feeling concern when I see an individual with a brow puckered in wrath pounce upon some helpless wretches belonging to the insect race, his expression implying that he considers death alone almost too good for them. Myself an insect-killer under some circumstances, I lie exposed to an extent to the *tu quoque* argument, yet there is a justification which I can plead; so also has the horticulturist, but he ought to remember (what many forget), that the injuries we receive from insects are more conspicuous than the benefits, and yet the latter are more numerous than might be supposed, and some of these are derived from insects which are deemed pests, and actually are so to some extent.

I venture upon these prefatory remarks, because when subsequently discussing the histories of a portion of the gardener's enemies, reference must be made to modes of extirpation—or, at least, of diminution, and thereby I may give a stimulus to insect slaughter. Personally, I shall probably reap one benefit, I shall eat fewer insects (for in spite of all the care of cooks, some species come to table at times); yet, on the other hand, should my dreams be haunted, like those of the old Greek hero, by the ghosts of my victims, I may behold, in addition to the insects which I myself have killed, those also which I have slain by proxy. Think of this, friendly reader, and go not to work too rashly in the task of insect-destruction; rather emulate the spirit Izaak Walton shows—when advising his pupil as to the best method of transfixing the worm upon the hook, he says that he is to handle it as if he loved it! Who knows but that the new generation of gardeners will be more sensitive than the past? Such a thing may be as that a man will be heard soliloquising after the manner of Sterne. Surveying a caterpillar on the path which he has just crushed, one might hear a gardener exclaiming, "Yes, there thou liest, poor creature! Thy life, brief to me, though seeming ages to thee, is momentarily terminated. Where are now thy sixteen legs (let me see, no, six legs and ten claspers), thy twelve segments? They are blended in an indistinguishable mass! Thy head, also, is a ruin—thy head, in which, perchance, there dwelt pleasing visions of days to come, when thou shouldst scorn earth, and pass in the aerial regions from flower to flower." However, this has not yet come to pass, and gardeners *now* look upon insects as their natural enemies, and kill them without superfluous tenderness. But, to speak seriously, the singularities of insect structure and insect habits, when they become known to persons of intelligence, do, indeed, awaken a very different feeling towards these creatures than may be expected to be found in one who, like Mr. Wood's friend alluded to in "Common Objects of the Country," supposes that caterpillars are "only skin and squash."

In my earlier entomological days my liking for insects having been perceived by some of my friends, I received one morning a donation in the shape of a wooden box, the contents of which the giver expected that I should be much delighted with. Opening it, there was in view the unsightly grub of the cockchafer which had just been disinterred. My gratitude for this rather undesirable gift was a little forced; butterflies and moths I loved, but beetle larvae were then rather beyond me. Throughout the winter months these creatures are turned up both in gardens and in fields, and not only by man accidentally, but intentionally by birds, rooks and starlings especially, and, as it often happens in similar cases, the birds are blamed for disturbing the soil when they rather deserve thanks.

The larva of the cockchafer (*Melolontha vulgaris*) is most injurious in those gardens, of which there are many throughout our land, which have approximating to them an extensive stretch of grass fields; in these the insects have their head quarters, and make incursions to the neighbouring garden ground. In the market gardens of some districts this larva has been noticed to be particularly partial to the roots of the Strawberry and the Rose; in meadows Lucerne and the cereals are frequently attacked by it, and there the results are more notable than in the instance of stronger and taller plants; the aspect in some cases leading us to suppose that some insect pest had attacked the growth above instead of below the ground. Figuiar seems to think that this insect is more abundant now than formerly, and because the land is more efficiently cultivated. The fact is well established that the female beetle chooses by preference light and manured soil when she can get it, which may seem to favour his idea; yet by the accounts which he himself gives of

the multitudes recorded to have appeared in other days, it does not appear that in recent times the cockchafer has done an injury equivalent to the increase of cultivated ground. In Prussia the species did much damage in 1835, and in France in 1854. But farther back we have astonishing accounts of the profusion in which cockchafers appeared, making due allowance for exaggeration. In 1574 this species was abundant in England—so abundant, it is said, as to stop the working of mills on the Severn. Ireland, too, in 1688 had so great a profusion that the insects did much damage in their adult state, the sound of their wings at night being described as terrific; and, as a last resource, the Irish fell to and ate them. But it is most amusing to read, that the cockchafers, having caused a famine in some districts, were summoned to appear before an ecclesiastical court at Lausanne. Sentence was duly passed upon them, and they were ordered to quit the territory—a capital decision, the only difficulty how it should be enforced.

One thing is quite obvious in the history of the cockchafer. This is, that it appears periodically in more plenty, owing to the three years occupied by its transformations. 1865 and 1868 were cockchafer years in most places, so that we may presume that there will be more of the perfect insect than usual about in 1871. Other years a certain number of stragglers appear. I saw the insect in various places during 1869 and 1870. This remark, of course, applies only to the cockchafer in its winged state; in the larval stage it is active enough in the interval, and likely to be most destructive towards the close of the third year; when getting sizeable it is still more voracious than when young. The eggs of the cockchafer are deposited in the ground by the female, with the aid of her first pair of legs; the number of eggs usually being about thirty. Hatching in a few weeks, the young larva immediately begin to feed, though at first they are only moderate consumers. In the winter, at least during the severe part of it, they become torpid, taking the precaution then to bury themselves at a greater depth. After numerous changes of skin, towards the autumn of the third year from their appearance from the egg, they are of mature size, and pass into the pupal stage. This is of brief duration, the beetle emerging in October or November, but, singular to say, it remains in the retreat, being very soft, until the spring, when it works gradually to the surface. Hence a sharp frost in the early spring sometimes gives a check to their increase by killing some of the beetles ere they are fully hardened; and in the same way also some of the larvae are destroyed. When we see cockchafers about in the daytime we are apt to form a very mistaken notion about them. Languid and stupid as they seem in the sunshine, which they always avoid when they can, they are lively enough after dark, and eat the leaves of various trees, and in places where they are particularly plentiful woods and parks suffer severely. It has been suggested as desirable that these insects should be hunted down in this adult state rather than as larvae; they may be shaken from trees during the day, and the killing of the females includes, of course, the destruction of their progeny. The only way of getting rid of the larvae is to turn over the ground, if you can, where they occur, and then they must be either picked up or killed by the sprinkling of some compound. In Russia, we are told, "the people have reached the advanced stage of making cockchafer flour, which at present is only employed for the purpose of making cakes for young pheasants, partridges, or quails." The common designation of the cockchafer larvae in many English counties is the "white grub." The Sussex folks are reported to call it "Job-hassett," a rather dubious name.

Amongst the dead leaves which are swept up in the vicinity of Gooseberry and Currant bushes, are some of the winter retreats of the Currant Moth (*Abraxas grossulariata*), and if these are not burnt, or otherwise effectually disposed of, the young caterpillars early in the spring emerge to renew their attacks on their favourite bushes. Many, however, remain on these through the winter, spinning a leaf to a twig as an anchorage, and, screened by this, defying the cold and the moisture: so that, in spare moments, the gardener will do well to pick off carefully any leaves he sees remaining, more particularly on the Gooseberry and Black Currant. The caterpillars, however, will, if need be, feed also on the Red Currant. A more effectual way of keeping this caterpillar under is to examine the leaves for the yellow eggs, which are laid in June and July. Mr. Newman states that he has often watched the female moths "not only in the evening, but even in the middle of a warm day, depositing a single egg on a leaf of Gooseberry or Black Currant, and then flying off to another." According

to my experience in our gardens at the west of London, the eggs are very often laid in small patches, sometimes about a dozen together. This species is notable amongst our Lepidoptera, as being one of those where there is a degree of resemblance between the colouring of the caterpillar and the



Abraxas grossulariata.

moth, though the latter is liable to vary. Hatched in the summer, these caterpillars make their appearance perceptible on the bushes, and in very warm seasons they will be of good size in the autumn ere the time of hibernation, though ordinarily they are but small when they cease eating. In the former case they are apt to verify the proverb, that "more haste is less speed," for becoming conspicuous on the Goose-berry bushes when the leaves are falling, they are a prey to birds, and never become noths at all. But it is in the spring months the gardener has most reason to dislike *A. grossulariata*, for the caterpillars go to work eagerly, and eat not only leaves, but also the buds, and even, as I have observed, the flowers in some seasons. The moth, which "flaps" very languidly about, rarely going far from its native spot, is commonly thought a butterfly by the unscientific.—J. R. S. C.

WORK FOR THE WEEK.

KITCHEN GARDEN.

THE state of the weather prevents much being done in the garden. See that the *Artichokes* are securely covered to prevent their being injured by frost. The young plants of *Cauliflowers* in frames must be protected from severe frost by covering the lights with mats; if there are any in the open borders protect them with arched sticks and mats. Lay a coating of long dung over the ridges of *Celery*, particularly that required for use, to preserve it from frost. Wheel manure to vacant ground when the weather is frosty and this can be done without injuring the walks, and let all spare ground be turned up so as to expose it to the action of the weather as long as possible. For land which has been long cropped with vegetables a dressing of fresh loam would in many cases be preferable to manure, and where this is wanted and can be procured, it should be in readiness, so that advantage may be taken of frosty days for wheeling it upon the ground. Where fresh soil cannot be obtained, charred vegetable refuse—such as prunings of shrubberies, edgings of walks, and many things which turn up in the course of the season, may be cheaply made to form an excellent substitute.

FRUIT GARDEN.

Make a point of regularly examining every week all the choice kinds of fruits that may be approaching ripeness, or which are found not to be keeping well, so that everything may be used at the proper time, for the finest Pears are worthless enough if allowed to become over-ripe before being used, and the same is the case with many varieties of Apples. Also look over the whole stock as often as time can be spared, removing any fruit that exhibit symptoms of decay, and put them aside for immediate use. Any of the choicer kinds of Pears that do not appear to ripen properly in the fruit-room, should be removed to a warm dry room for a few days. This will be found to greatly improve them. Keep the fruit as dry and cool as possible, and if the frost is excluded the fruit-room can hardly be too cool when the object is to preserve the fruit plump and sound for a long time. No newly-planted fruit tree should remain without a mulching over the roots. Standards must be securely staked, and they should afterwards be frequently looked to, as they are sometimes apt to get loose and rub against the stake; if preventive measures are not taken the trees will then be seriously injured.

FLOWER GARDEN.

The winter weather which we have lately experienced may have served to remind those who have neglected to afford pro-

tection to tender Roses, and other things which are found to require this care, that its application cannot with safety be delayed any longer. The flower garden is now of meagre interest, as there is little to be done save those routine operations which ensure high keeping. Take advantage of frosty mornings to manure Rose beds, and renew the soil in beds intended for masses of flowers. Endeavour to forward in inclement weather the preparation of labels and pegs for the beds, or any other article which will be wanted at this busy time of year. Put all implements in good order for work. Be not satisfied with having done things well, but be always striving to improve. Set your standard high, and endeavour to reach it. All planting should have been finished. Complete alterations when the weather is favourable. Any trees or shrubs loaded with snow should have it carefully shaken off. The places intended for Hollyhocks, Dahlias, &c., next summer, should be prepared by deep digging, and working-in plenty of rotten manure, for there is generally as much time to spare for this kind of work now as at planting-out time, and by preparing the spaces at the present season the soil will be in better condition than would be the case if the work were delayed until planting-out time. Shrubberies may be thinned, where this involves only the cutting-out of overgrown plants or lopping deciduous trees, but where evergreens generally require pruning, this is best done in March; for although, when the winter proves mild, such work may be safely performed at any time, it is safer to defer it till spring.

GREENHOUSE AND CONSERVATORY.

While frosty weather continues he satisfied with as low a night temperature in all plant houses as it will be safe to keep, taking advantage of bright days to increase the temperature, and using a little fire heat in order to be able to admit fresh air to dispel damp, &c. The proper night temperature for the conservatory very much depends upon the kind of plants it may contain. Where *Camellias*, *Epscrises*, *Heaths*, and other winter-blooming plants form the principal inmates, 40° will be sufficiently high, and with a dry atmosphere the temperature may safely be allowed to sink a few degrees on hard nights; but in cases where the hardier kinds of winter-flowering stove plants are brought in while in bloom, 45° should be considered the proper mean night temperature. Let whatever watering may be required be done early in the day, so as to allow advantage to be taken of sunshine, whenever that may occur, to give air for the purpose of drying the foliage, &c. Many persons appear to entertain an opinion that very little attention is needed to properly supply plants with water at this season, and they only look over their stock at intervals of several days. I would, however, caution young gardeners against this mistake, and advise them to examine every plant at least on alternate days, deferring the application of water until it is really required, and then giving a liberal soaking. Attend daily to the removal of dead and decaying leaves, and directly any of the flowering specimens become shabby remove them to some out-of-the-way place, taking care that they are placed under proper conditions as to temperature, &c., according to their wants, and, if possible, supply their places with others in full beauty. Where necessary, the leaves of plants should be sponged over and thoroughly cleaned, and twiners pruned, trimmed, and put into proper order for the spring. Early *Hyacinths* will soon be in flower, and with care a succession of them may be kept up till spring. For late flowering, the bulbs, if not already planted, should now be put in. The best pots are 5-inch (18's) for one bulb, and 6 or 7-inch (32's and 24's) for three bulbs; and when a fine display is sought for, three bulbs grown together in one pot secure that object much better than single bulbs. For potting, the soil should be as rich as possible, such as one-half fresh loam, cut from a pasture with the turf decayed in it, well-decomposed cow or horse manure, and a small quantity of clean sand well intermixed. If, however, this kind of compost cannot be obtained, then the lightest and richest at command must be employed instead. Drain efficiently, and after filling the pots lightly with the soil, place the bulbs upon the surface, slightly pressing them into the soil. After watering liberally set the pots, thus planted, out of doors on a dry bottom, and cover about a foot deep with old tan, ashes, sawdust, leaf soil, cocoa-nut fibre refuse, or any other light material. After remaining thus for a month, the bulbs will be sufficiently rooted to render it safe to remove them to a gentle bottom heat of about 55°, introducing the pots in numbers proportionate to the demand at intervals of about a fortnight. In this manner a succession of flowers will be secured until those in the open air come into flower. In forcing, en-

deavour to prevent the roots from penetrating the fermenting material.

FORCING PIT.

Succession plants and bulbs should be introduced and treated as previously directed. A weak solution of tepid manure water applied to almost every plant when showing flower will be found beneficial. Moderate fumigations with tobacco should be applied occasionally to keep the enemy at a respectful distance, prevention being better than cure.

COLD PITS.

Where the stock of bedding plants has to be wintered in structures of this description, the present will be found a trying time, and the utmost vigilance and care will be required to preserve the plants from harm. Apply sufficient covering to the glass, and also to the walls of the pits or frames to ward off the effects of the most severe frost, and embrace every chance of admitting air and removing decaying leaves, in order to prevent damp and mildew. Plants when covered up for several days should not be suddenly exposed to bright sunshine, but should be partially shaded for a few hours, admitting air in the meantime if the state of the atmosphere will permit.—W. KEANE.

DOINGS OF THE LAST WEEK.

WHAT fine suitable weather for this Christmas eve, with the roads like iron and the air some 20° below freezing point! How suitable, indeed, for all who have a comfortable home to go to, a nice blazing fire to sit round, and plenty of eatables and drinkables to keep out the cold! We are none the less thankful and grateful for the blessings and comforts we possess in our humble homestead; we none the less wish for all readers and friends (and one term might well do instead of two, as our readers are mostly our friends) a merry Christmas and a happy New Year, though we cannot help thinking on the wretchedness and misery now experienced by two great nations on the Continent, who are doing their best to injure and destroy each other. And coming close to our own doors, we cannot but think of the scanty supplies in many a household, owing to the want and the scarcity of employment at this cold season of the year. To every man with a spice of independence in his nature no greater boon can be given than the opportunity to labour, and thus support those near and dear to him. The making and finding work for a few weeks now would, in many districts, be the best of all charity, because there is no test like work for discriminating between the claims of those who may solicit our help. Some of us who think we have seen a little in our time are, nevertheless, often deceived. Well, it is better to trust a hundred times and be deceived than to have the wrapped-up selfish spirit, "never to trust at all." For all able-bodied claimants on our sympathy there is no test like the labour test. The shuffling, scheming idler will soon slip away; the honest, worthy man will be glad to continue and do his best.

The work of the week has chiefly resolved itself into the following:—Collecting and carting leaves, wheeling the rubbish heap on the kitchen garden, forming new rubbish heaps, turning over soil, digging and trenching when the weather would permit, and using a little litter for protecting Celery, Radishes, Lettuces, Cauliflowers &c. in cold earth pits.

Planting was proceeded with until the frost arrested us. It may be done on a sunny day, even if there has been a sharp frost, but it is always unadvisable to plant in frosty weather when the roots must be for any considerable time exposed to the frost. We have known large failures take place from this cause alone, even when the ground was not so hard as to prevent its working well. When planting on a large scale for forest or covert, the trees are often allowed to lie on the surface a little time before planting, and though that does no harm in a mild dull day, the roots are easily injured, if not destroyed, when exposed for a short time to a dry frosty air. This is a very different thing from the roots being partly placed in soil frozen in the natural way; as that takes place gradually, the roots are secured from the air, and have access at the same time to the storehouse of heat in the earth beneath them. This, which applies to common planting, applies still more thoroughly to the planting of shrubs and fruit trees with or without balls of earth. The roots should never be exposed to a frosty air. In planting, if the plants are valuable and of some size, too much care cannot be taken in spreading out the roots, and packing them in layers. When small plants are to be turned out in numbers, no better plan can be adopted than

giving the operator a stout ponch or apron to hold the plants, so that each may be only a short time exposed at the roots before the earth is fastened firmly round them.

Last season we made some remarks on planting by the dibber, and showed how the one oblique stroke did the planting, and far better than a dozen small strokes. For small plants nothing in general beats the dibber, but as we live we learn; and in some cases, as planting thousands of seedling Gorse for covers, we think in many cases, instead of digging and dibbling, the plants will do better if a deep slit be made by the spade thrust down, then moved from side to side in the firmish soil, the roots spread their full length in the opening, and then firmed by treading. We know that severe frost has no effect on such afterwards in comparison with small plants carefully dibbled. We have often had the latter loosened and next to thrown out of the ground by a severe frost.

Although repeating ourselves, we may remark there is nothing more difficult to get attended to by men taken on merely to give employment in planting than this—never to plant a shrub or tree more deeply than it stood before. Nature has clearly pointed out the exact place whence the stem should rise and the roots descend, and thousands of failures, as deaths and a languishing existence, take place every season, simply because that part of a plant that Nature intended to be exposed to the air is sunk down and covered with soil. It is so easy to do this, and the trees look so much firmer in consequence, that all but experienced planters will be sure to commit the error, unless at first carefully superintended. Thousands and thousands of trees die from this cause alone, and the proprietor hardly ever thinks of this as a cause of failure, partly because of the benevolent belief that any man who can wield a spade on an emergency can surely plant a tree well enough. We cannot say what the experience of others is in this respect, but in different parts of the country we have found it very difficult to get this simple matter attended to.

This is less to be wondered at when thousands who have little gardens have never acquired the knowledge how to use a dibber properly. Only last spring we saw some hundreds of Cabbage plants hanging their heads most dolefully. They were waiting for the rains and winds to plant them. A push from the point of the boot would have brought them up. They were what old gardeners would have called "hanged outright." Apparently they had all received half a dozen strokes with the dibber, and yet the plants were loose. Two good strokes and one small one are all that are needed in dibber-planting. There is the one perpendicular stroke with the dibber to make the hole for the roots, then the dibber, say from 1 to 2 or more inches from the first hole, is thrust in obliquely, so that the point comes to the bottom of the first hole, and then is quickly brought with the intervening earth to the perpendicular. The plant is fixed as in a blacksmith's vice, so that you will more easily break it than pull it up. These two strokes do the planting. A third stroke with the point of the dibber across the last hole, partly to fill it, makes the job more workmanlike. But a great point would be gained if the dibblers comprehended the simple fact that the two strokes alluded to, and not a number, make successful planting.

Ice Collecting.—We never had a better chance, and being rather short of cart power, most likely we shall recommence on Monday, as the weather seems likely to continue frosty, and we shall make holiday at another time. Last year we had to content ourselves with ice we did not like, and in our single house had a good store left after a very free use. The ice we have had now is very clear, from rain water in ponds. All ice on the top of water coloured from manure yards should be avoided, if possible. Dirty ice always looks badly, and when used for delicate purposes is apt to leave a taint behind it. The purer and clearer the water the better the ice, and the more free it is from weeds, sticks, &c., the better, as they only help to hasten its melting.

As far as our own practice is concerned, we are not so particular in pounding the ice as we used to be, provided we can obtain enough of small ice to pack the larger pieces. Leaving cavities of air between large pieces is to be avoided, and more especially if the air should not be below freezing point when filling the ice house, as then every such body of warm air shut in would act as a waster and melter. In very small houses the well-pounding will be essential to success. From some few experiments made we are rather convinced that if we could obtain ice in regular large blocks, as from abroad, and built these blocks in a regular mass, and cemented them together

with water in a frosty day or night, such a mass of blocks would keep better than the finest pounded 1-inch or 2-inch-thick ice from our ponds. In a moderate-sized house or heap, we would be more particular in having enough pounded to pack the larger pieces than in having all pounded small.

Protection.—Many vegetables and plants have been covered-up several days and nights since the frost came. The great point in these cases is to make sure that in such darkness from covering there shall be no excitement to mere prolongation from heat. Although we had been in the habit of allowing young Cauliflower plants under hand-lights to become slightly frozen before covering them up, as far as we recollect, Mr. Errington was the first to recommend the practice in writing. The principle is a very important one when continuous protection is given, and in severe weather that continuous protection is better for the plants every way than exposing them to sunshine by day and great colds at night. As above stated, the great point is to be sure that there is no growth.

Several times we have had such things as Calceolaria cuttings shut out from light and air for a month in severe weather, but then we made sure that the air enclosed ranged from 33° to 37°, or thereabouts. There will be little growth or elongation until you pass 40°. On uncovering such plants, Cauliflower plants, &c., after the thaw came, and even then uncovering gradually, the plants looked as fresh after a month of night as they would have done after the usual night of fifteen or sixteen hours. This simple matter rightly understood would often lessen labour. Many cold pits and frames are uncovered and covered every day in severe weather, although they would be better if left for a time covered up, but only in such weather, and provided they were cool enough to afford no incentive to growth.

We have lately had appeals made to our sympathies, on behalf of gardeners who have to contend with a next-to-unbroken frost of several months in the counties in which they live. With every wish to oblige, we felt that in such a case we must pretty well keep our sympathies for ourselves and our *confères* nearer home. In such a case, with coverings for the roofs, or double glass, in winter especially, we think we could keep tender plants safe and yet not parch them up with fire heat; and in the case of plants that merely needed protection from frost, we would first let them be near the freezing point, and then keep them so by protection, and trouble ourselves but little with frequent uncovering. Gardening under such circumstances is a much easier affair than with us, where the weather is often so variable that in thirty hours we may have the thermometer at 20° below freezing point and 20° above it. It is not so much the cold, but the sudden variations in temperature, and alternations from wet to dry, that try plants and gardeners so much in this country, and make so many of us old and rheumatic before our time.

A thinking shrewd man in such weather as this, where there are heated glass houses would soon save the best part of his wages in fuel alone. To use a common expression of the day, there are as respects furnaces *stokers* and *stokers*, the one as distinguished for saving as the other is for wasting.

On this we do not enlarge, as it has lately received some attention; but we would like to notice one thing in the way of protection, alluded to, we think, last year, but perhaps not yet sufficiently noticed so as to enable us to see the benevolence of the Supreme even in such a simple matter as the greater penetrative power of warm air over that of cold air. Thus, with the temperature from 5° to 20° below the freezing point, it is no difficult matter, with a mat and a little litter frequently turned, to keep the frost out of a cold pit; but only let your temperature outside rise to 10° or 15° above the freezing point, and how soon will that rise in temperature find its way through all your covering! We presume the same principles of radiation and conduction act in both cases, but we have often been struck with the great difference in results. It would seem we are more able to keep out cold than to keep out heat, though by colour, &c., we can do a good deal as respects the latter.

Two hints we must here give to the inexperienced. First, when a change of weather takes place from cold to warm, do not at once expose plants that have been kept some time in darkness to the full blaze of a bright sun. Better remove the covering by degrees, and give at first a subdued light. Then, in the second place, use similar precautions in all cases where the frost, even in a limited degree, has found an entrance. Let the warmer air find its way in, and thaw gradually, before you remove the covering and its attendant darkness; then admit light, not all at once, but by degrees if the sun is bright. A number of years ago we could afford to make an experiment

with a lot of Calceolaria cuttings in a cold pit in January. They were all frozen a little before sufficient covering could be given. On the change of the weather one light was uncovered at once, before the plants were thawed inside; that light gave us few plants for the flower garden. The others were not uncovered for two days after the thaw commenced, and then were slightly shaded for a couple of days more; and though the little plants were pretty stiff with the frost, not one of them failed afterwards, and though shut up from three to four weeks, they looked, after the above precautions, just as if they had never felt the cold, and never had more than a night of the usual length.

But for the space occupied we might have said something of firing, but that and other general matters have been pretty well attended to of late. Meanwhile, in all heated houses, let us say to the inexperienced, that it is safer to let the thermometer fall 5° or 10°, provided that is within safety-point, than to have a high temperature from fire heat in such severe weather. Then, again, provided a little air is given at the apex early, so as to prevent drip from the glass, it is better to give very little air, so as to necessitate less fire heat. Avoid the extremes of fire heat and sun heat meeting together. Lastly, use no more water than is absolutely necessary. A plant will sometimes flag, not so much from dryness at the roots as from a sudden change from dull to bright weather, and a slight shading or dewing of the foliage would often be better than watering at the root. If keen dry frost should continue, a slight sprinkling of the stages and floors of plant houses will often be better than watering or even sprinkling the plants themselves. The wetter the soil in a pot the cooler will it become by evaporation and radiation.—R. F.

TRADE CATALOGUES RECEIVED.

J. Carter, Dunnett, & Beale, 237 and 238, High Holborn, London, W.C.—*Carter's Gardeners' and Farmers' Vade-Mecum.*
J. Veitch & Sons, Royal Exotic Nursery, Chelsea, London, S.W.—*Catalogue of Garden and Flower Seeds for 1871.*

TO CORRESPONDENTS.

* * * We request that no one will write privately to any of the correspondents of the "Journal of Horticulture, Cottage Gardener, and Country Gentleman." By doing so they are subjected to unjustifiable trouble and expense. All communications should therefore be addressed *solely* to *The Editors of the Journal of Horticulture, &c.*, 171, Fleet Street, London, E.C.

We also request that correspondents will not mix up on the same sheet questions relating to Gardening and those on Poultry and Bee subjects, if they expect to get them answered promptly and conveniently, but write them on separate communications. Also never to send more than two or three questions at once.

N.B.—Many questions must remain unanswered until next week.

CONIFER SEEDS.—R. H. W. thinks it would be to the advantage of seedsmen to advertise seeds of Conifers, as many, like himself, are desirous of purchasing them.

PRUNING A POMEGRANATE (*Subscriber*).—Against a south wall it is difficult to secure flowering from the trim appearance that is usually required. Thin out the old wood, and leave the small twiggy well-ripened shoots, which must be encouraged or there will be few flowers. Grafted plants are to be preferred to those not worked, as they do not grow so vigorously, but flower much more freely and longer.

RHUS COTINUS PRUNING AND PROPAGATION (*Idem*).—The only pruning required is to thin out the shoots which are very much crowded, and to shorten the irregular growths, so as to form a more compact head. There is but little necessity to prune to induce flowering, as it is very free-flowering in a well-drained warm soil and situation. It is propagated by seeds, and by layers, which root freely if made in spring and detached in the autumn. Cuttings of the ripened shoots strike if inserted in sandy soil in a sheltered place; it may also be increased by cutting the roots into lengths of 5 or 6 inches, and placing them about an inch deep in the soil.

SMALL MELON (*Idem*).—Queen Anne's Pocket is the smallest, and perhaps the handsomest Melon, but is of little use. Paradise Gem is a fine new sort, scarlet-fleshed, and is a fit companion of Pine Apple Gem, green-fleshed, an early and productive kind. Scarlet Gem is handsome and good; but for flavour perhaps no Melon can compete with the old Egyptian, which, however, is not handsome.

HEADING MAIDEN PEACH TREES (*Amateur*).—For fan-training the trees ought not to have the lowest eyes started; then cut them back to five or six eyes if these are close together, or if distant, to three. As your trees have started the lowest eyes, you have no alternative but to head above the second tier of shoots, shortening the lowest side shoots or laterals to four, and the two highest to two eyes each. If, however, the side shoots are wide apart, then head above the first two, and shorten those to two eyes, as shown in your sketch by the bars. There is no advantage in

such trees except for forming pyramids. For dwarf fan-training we do not like them. "Fruit Gardening for the Many," will suit you. It may be had from our office for five stamps.

CYCLAMENS AFTER FLOWERING (*Q. Q.*)—After they are removed from the sitting-room, place them in a pit or frame, and protect them from the frost. Keep them watered, and in June plant them out in a border protected from the direct mid-day sun. In August take them up and re-pot them, placing the pots on ashes in a cold frame. The soil at all times should be moist, but there is no necessity for watering after they are turned out into the open ground. When moved from the sitting-room, they must be kept safe from frost.

GERANIUMS IN ROOMS (*Idem*).—In frosty weather you will need a fire, but as long as the temperature does not fall below 35°, there is no necessity for one. It is necessary to keep out frost. There can be no question they winter better without fire heat than with it. So long as your room is above 38° have no fire, and keep the plants dry, giving a little water occasionally to keep the wood from shrivelling.

TRANSPLANTING STRAWBERRIES (*Idem*).—We would not remove the runners planted last August until February, or early in March if the weather be unfavourable in February. If carefully lifted, preserving to each a good ball, the plants will be little the worse, watering being carefully attended to in dry weather.

VARIOUS (*Q. Q.*)—As regards the small vinery which will not be put up until May, we do not think you would gain a season by your neighbour growing your Vines in pots from February to May; but you would gain a good deal if the Vines, instead of being grown in pots, had the roots laid out nicely in shallow baskets, and were thus started in the house, and the baskets were then sunk just as they were in a nicely made border in the end of May or beginning of June. With warm water and a little covering there need be no check to the roots, which there would be in turning them out of a pot. The Black Hamburg and Lady Downe's will succeed well enough in the same house, but the latter should be planted at the warmer end, and even then the bunches will only be getting fully ripened when the first have all been need. In a late house we have some Lady Downe's now not more than ripe, but the Hamburgs are quite sugary and showing signs of shrivelling. The chief reason for having the flue, as referred to at page 478, under the front stage is, that the heat rising there is more easily and equally diffused. A flue under the centre stage would give off just as much heat; but as heat always rises it would not so readily keep cold from the front glass. When we have heated houses by flues or pipes close to the back instead of the front wall, we have always liked to have more heating power. True, there will be a circulation, the heated air rising to the apex and falling down to the front. This is best done when the heating medium is partly confined, and there are openings in front with air flues beneath the floor connected with the heating medium. With the flue near the front, the heated air rises at once against the front and the lower part of the roof glass. In your case, however, if you had the flue in front it need not interfere with the planting your Vines inside. Heat ascends, and will not hurt the roots nor the stems if a foot from the flue. All the Pears you mention will do well as bushes or pyramids. We are surprised you do not place among them two favourites—Marie Louise and Louise Bonne of Jersey. In your case we would decidedly prefer bushes and pyramids, but we can have no objection to cordons, a capital plan for filling every spare space; and a little protection for them when in bloom would be desirable.

VINES ON GLASS-COVERED WALLS (*Amateur*).—There is no objection to the perpendicular glass remaining in front of the Vines during the winter. It will be more beneficial than injurious, though, all things considered, we should be inclined to remove it, and not replace it until the Vines began to grow.

PEAT SOIL FOR GERANIUMS (*Idem*).—It would be good to mix with your soil for Geraniums, but it will not supply, or only to a small extent, the deficiency of decomposing vegetable matter, as leaf soil or manure would do. Water freely in dry weather, and once a week with liquid manure; 2 ozs. of guano to a gallon of water will be sufficient, a plentiful supply being given, and not dribbled.

DETERMINING THE EXTENT OF A KITCHEN GARDEN (*A. B. C.*)—Your question admits of no conclusive answer. The wants of an establishment vary considerably, for it is not so much what each person eats, but what is to be placed on the table. We have no means of estimating the extent of ground that will be required for producing a supply of vegetables for each person, varying as people do in their likes and dislikes; but we have known a kitchen garden of three acres supply a family of thirteen members, and an average of fifty besides in the servants' hall; and an acre and half barely meeting the wants of a family of three, with nine servants; whilst we have known one-eighth of an acre supply a family of four, with five servants; and three-quarters of an acre supply seven, with four servants.

LIBONIA FLORIBUNDA LEAVES FALLING (*J. C.*)—We can only account for the leaves falling from the plant receiving a check. Probably it has been grown in a warm close atmosphere, and received a check in removal. We think it will recover. It is usual for the plant to lose a part of its leaves in autumn. We have it succeeding well in a greenhouse.

NAMES OF FERNS (*Idem*).—The Silver Fern is *Gymnogramma tartarea*; the Gold, *Gymnogramma ochracea*; and the green frond, *Litobrochia (Dryopteris) palmata*.

COCA-NUT FIBRE FOR RHODODENDRON BEDS (*C. B.*)—The fibre, which is the waste of the brush and mat manufacturers, is of no value for plants, though for plunging pots in and mulching it may have value. This fibre is very different from the refuse, which is so much valued as an ingredient in composts for plants. The latter is like mahogany sawdust, and is a good substitute for peat. It may, therefore, be used for mixing with the soil intended for Rhododendron beds and all plants requiring peat soil, though for Azaleas, Heaths, and all hardwooded plants, which for the most part have very delicate fibres, it requires to be old, two years not being too old. Used fresh it is too open for those plants. It is also valuable as a compost for Ferns and Orchids—indeed, there are few plants not improved by its application.

ACHIMENES TREATMENT (*A. B.*)—Remove them from the soil early after the middle of February, and place them in pans well drained, and filled to within half an inch of the rim with a compost of light fibrous loam two parts, leaf soil one part, and a fourth of silver sand. Place

them on the surface close together, but not touching each other, and cover lightly with fine soil. Water very carefully, but have the soil moist, and place the pans in a hothed with a bottom heat of from 70° to 75°. A Cucumber frame will answer well. In the course of a few weeks the plants will have grown a couple of inches; place them in pots or pans, taking them up carefully, and placing them about 1½ inch apart, the weakest at the sides, and the strongest in the centre. The pots should be well drained, and if pans are used they should not be less than 6 inches, better 8 inches deep. A compost of two parts turfy loam, one of leaf soil, and one of well-rotted manure, with a free admixture of silver sand, will grow them well. It is well to pot that a slight top-dressing of soil can afterwards be given. Return the pots to the hothed, or if not convenient, place them near the glass in a vinery, stove, or any house with a moist growing heat of from 60° to 65° at night, and from 70° to 80° or 85° by day. When they need staking attend to it, and top-dress with fresh compost. Let them have a brisk heat and a moist atmosphere, watering as required, but taking care not to make the soil sodden by too frequent watering, and, on the other hand, not allowing them to suffer from dryness.

VINES FOR A GROUND VINERY (*M. Ross*).—All of the Vines you mention will do; but we would recommend White Muscadine, Grove End Sweet-water, Early Maltingre, and Black Prince for your ground vinery.

GROUND VINERIES (*Subscriber*).—It may be possible to get one piece of glass 7 feet long, by 2½ inches, but the way in which ground vinerias are usually glazed is by the panes of glass being the width between the upper and lower frames, and of any length you please. They are usually 20 inches.

IMPORTING ORCHIDS FROM INDIA (*E. L. J.*)—The very best time for Orchids to reach England is during the months of March and April. By this restriction it is impossible for the plants to be sent from India in a growing or unripe state, and they arrive in this country exactly at the right time to make good growth the same season. The following is a short list of species to be found in the neighbourhood of Bombay:—*Aerides maculosum*, *odoratum*, *Fieldingii*, *crispum*, and *Warneri*; *Bolbophyllum*, various; *Cologone odoratissima*; *Dendrobium barbatulum*, *nobile*, and *Pierardi*; *Saccolabium guttatum*, *Sarcantium* several species, *Vanda Roxburghii*; and many others of less importance, especially *Dendrobium*.

DOUBLE GLAZING (*J. Mackenzie, M.D.*).—We are not aware of any regularly recorded temperatures under the different circumstances alluded to. We have mislaid the results of some small experiments of our own years ago; but we recollect that in cold weather, when we covered a two-light box with double sashes, though from the laps the enclosed space was anything but air-tight, that similar thermometers, one laid on the upper light and one on the lower light, so as to be easily seen, often showed from 5 to 12° difference. Will some reader help our correspondent to details more definite as to the difference in temperature between double-glazed and single-glazed houses?

HOT WATER CIRCULATING DOWNWARDS.—"Will Mr. Giddings describe how a pipe can start and descend 22 feet in 100 feet, and then return to the same point on a level? If, as I think, that the pipes have first a rise from some other house and the boiler the flow pipe, as Mr. Giddings terms it, is nothing more nor less than a return pipe, and has no practical effect whatever, neither does it help 'POOR GARDENER' or—H. BAILEY."

CALADIUMS (*E. C.*)—The party you mention says his mode of growing them differs but little from that described in more than one place in our pages, excepting that he uses poorer soil. His mode of culture is as follows:—After the plants are no longer ornamental they are set aside in some dry place, often a vinery, and but very little water given; still they are not kept quite dry, and when the foliage is quite gone the pots are stored in some place warmer than an ordinary greenhouse. In spring the Caladiums are brought out and re-potted, and placed in heat, using for the first potting a mixture of rough peat and maiden loam, with charcoal for drainage, and adding sand to the mixture if the peat does not contain enough of it. After growing a little while re-pot, using a much poorer soil this time, very often the sweepings of the potting shed, as a too rich material to grow in, however conducive to robust health, diminishes the high colouring which constitutes the beauty of this plant. He considers it unnecessary to maintain the high temperature so often recommended, as plants so reared are unable afterwards to endure a position in the conservatory.

NAMES OF FRUITS (*H. Howell*).—The Apples you have sent are Pigeonnet. The name certainly does not occur in the "Fruit Manual," but you will find the variety described in "British Pomology." It is only second-rate in England. Those you sent are good.

NAME OF PLANT (*Original Subscriber*).—*Cerastium tomentosum*.

POULTRY, BEE, AND PIGEON CHRONICLE.

THE CHRISTMAS MARKET.

We promise ourselves, as soon as space will permit, to give an account of the Christmas market that may be interesting to our readers. At present, while the fast-recurring shows and the josts that follow them absorb our space, we are perforce content to notice the salient points of that which has just terminated.

No market ever opened with brighter prospects for the wholesale, or more gloomy for the retail, than the Christmas market of 1870. Poultry had been very dear throughout the spring, and it was said the high prices had caused those who had poultry to kill it young, believing—and we agree with them—that it was better to ensure a good present price than to run the risk of many months only to achieve the same result. Then it was said the French supplies, which are enormous during the Christmas time, amounting to many thousands of Geese and

Turkeys, would be altogether wanting, and so great prices were asked. Those who required the best goods were obliged to buy at very dear rates. Then the supply continued and buyers were shy, but the elements fought for the wholesale. A frost set in, and made it little risk and no labour to hold. But the arrivals continued and the sales were small; Christmas-day was coming, no sale afterwards, and prices wavered. Every time there was an hour's good trade an attempt was made to raise prices, but it failed, and they closed lower than they began; still, they were good and remunerating for sender and salesman. There was one point well worthy of notice. It is said, "Love laughs at locksmiths;" and we may add, Trade laughs at restrictions. On Friday, spite of Prussian invasion, famine, and riotous mobs, a very large consignment of Geese and Turkeys came in from France.

GAME FOWLS AT THE LEEDS SHOW.

In looking over the Game classes at the Leeds Show I sought in vain (with some few exceptions) for the well-formed, compact, and high-crowned bird of days gone by; indeed, it is evident that a certain portion of breeders discard quality for coarseness. Several pens consisted of very long-sided birds, the back running in a straight horizontal line, with ostich-shaped necks and carriage, long weak thighs and legs, flat tucked-up breasts, and these birds were spiritless. Birds of this class are mostly heavy-fleshed, and not possessed of that firmness and muscular power natural to a pure well-bred Game cock. I suppose some judges prefer this style of bird, but I have no hesitation in saying that cocks so formed do not bear the excitement, or changes, of confinement and travelling so well as, nor are they equal in constitution to, birds which are fall in the breast and girth.

In breeding we ought to strictly perpetuate soundness of constitution, selecting for parents those which are the best in shape and other particulars coupled with good health.—**YORKSHIRE.**

NEW STANDARD FOR LIGHT AND DARK BRAHMAS.

THE North-west (U.S.) Poultry Association, believing the European standard of excellence for Light Brahmats to be both incorrect and faulty, has in solemn convocation decided upon a new one, which we copy as follows from the *Poultry Bulletin*:—

DESCRIPTION.—A Light Brahma cock should have a well-defined pea comb, standing erect and firm, and leaning to neither side of the head.

Beak short, strong, and well curved, one-third of which should be of "horn-colour," or, more excellent still, a clean black stripe running from the nostrils to point of beak, and covering in width one-third of the upper beak; the balance bright yellow.

Wattles and ear-lobes of equal length, with throat full, hanging flesh with wattles, and showing a tendency to sluff the feathers below the wattles when past twelve months old. Neck long and well arched. Neck hackle, feathers long, flowing and well down over the back and shoulders, and in colour white striped with black, the stripes extending up from the shoulder one-third to one-half the way to the head.

Back broad, flat and rising into the tail in such a way that for the part where the neck slopes down to the back, and up the tail to the point where the sickle feathers slope down, the curve thus defined should be identical with the curve of a Brahma egg, end to end, with the larger end towards the neck.

The tail should be black, the sickle feathers falling not much below the tail feathers proper, which should be expanded so as to form the letter A, with the bar left out, and should be well supplied with nicely curled feathers between black in colour and black fringed with white.

The wing should exhibit strong muscular power, and when extended the whole under surface should be black or very black brown. The "primaries" black; "secondaries," the upper half of each feather black, and lower half white, primaries well tucked up under the secondaries and adhering close to the body, and when the cock exhibits an excited vigilance for his flock, should show a black line along the lower edge and around the point of the wing, but when composed showing the black line slightly if at all. Saddle feathers should be abundant, and with the feathers of the body, white in colour.

The legs should be a deep yellow, or approaching a reddish yellow down the inside of the leg; well feathered, but not so grossly as to give any indications of vulture hocks. The hock joint should be well defined and not lose its identity in the "fluff." The lower surface of the "fluff" of the posterior should come just even with the hock joint.

The form of the body such that it will be of equal depth through the body just in front of the wings and just back of the hock joint, from back to breast and to posterior.

The birds should exhibit energy to such a degree as to put to rout any appearance of laziness or lack of courage.

The colour designated as white in this breed should be of that peculiar colour found in milk as it is strained warm from the cow, and not after it has been skimmed of the cream; neither should the colour be allowed to run into a buff as seen in some so-called Brahma birds.

The hen the same. Should have the same general appearance as the cock, though only in proportion, excepting that the posterior should be more fully developed; and she being deprived of the long neck feathers should present a body more the shape of a cube, with the lower corners rounded off, and presenting a neck the feathers of which are black, edged or laced with white; those presenting the centre two-fifths of the width black, being more perfect than those exceeding or falling short of it.

A cock seven months old and weighing 8 lbs. and a pullet weighing 6 lbs., with other points perfectly developed, should be entitled to the appellation of perfect birds; greater weight and perfection being considered in the superlative degree.

Perfectness of comb and wattles, colour, and carriage in the cock are of greater consideration than mere weight, and weight and form of body one of the first considerations in the hens, as it is now conceded that it is from these respectively that such characteristics are derived and produced in the progeny.

Scale of points:—

Size	2	Legs—colour and feathering	2
Colour	2	of the same	2
Head, comb and neck	3	Symmetry	2
Wings—primaries well tucked up under secondaries	3	Condition	1
		Total	15

The scale of points, it will be seen, differs greatly from that of the "Standard of Excellence," much less stress being laid upon colour and size, and more upon head and neck, and good tucking-up of the wing.—**A BRAHMA BREEDER.**

DURHAM POULTRY SHOW.

THIS was held on the 20th and 21st inst. The following is the prize-list:—

COCHINS—CINNA—Cinnamon and Buff.—1, 2, and Cup, G. H. Procter, Durham. **CHICKENS.**—1, G. H. Procter. 2, C. Sidwick, Ryddlesden Hall, Keighley. *Any other Variety.*—1, G. H. Procter. 2, C. Sidwick. **CHICKENS.**—1, C. Sidwick. 2, G. H. Procter.

BRAHMA POOTRA.—1, E. Leech, Rochdale. 2, F. Powell, Knaresborough. **CHICKENS.**—1, E. Leech. 2, A. H. Thompson, Yorkshire.

DOCKINGS.—1, J. White, Warlaby, Northallerton. 2, D. Rutter, East Rainton. **CHICKENS.**—1, J. White. 2, J. Braithwaite, Northallerton.

SPANISH.—1, W. Atkinson, Bishop Auckland. 2, E. Brown, Sheffield. **CHICKENS.** 1, T. C. & E. Newbit, Epsorth, Lincolnshire. 2, H. Morson, Bishop Auckland.

POLAND.—1, W. R. Patrick, West Wincup, Lynn. 2, H. Pickles, jun., Barby, Skipton. **CHICKENS.**—1, H. Pickles, jun. 2, W. R. Patrick.

GAME.—Black-breasted and other Reds.—1, T. Robson, Bishop Auckland. 2, E. Aykroyd, Ecclestone, Leeds. **CHICKENS.**—1, T. Robson. 2, T. Dent, Bishopwearmouth. *Any other Variety.*—1, E. Woodburne, Ulverston. 2, E. Winwood, Worcester. **CHICKENS.**—1, L. Casson, Ulverston. 2, Dr. Huxley, Edinburgh.

HAMBURGHS.—Golden-spangled.—1, T. Mitchell, Willington. 2, J. Morton, Marley Hill. **CHICKENS.**—1, J. Brown, Sunderland. 2, Ashton & Booth, Broadbottom, Mottram, Cheshire. **Silverspangled.**—1, H. Pickles, jun. 2, G. & J. Duckworth, Church. **CHICKENS.**—1, H. Pickles, jun. 2, Ashton & Booth. **Golden-pencilled.**—1, J. Walker, Birstwith, Ripley. 2, H. Pickles, jun. **CHICKENS.**—1, R. Moor, East Rainton. 2, J. Preston, Allerton, Bradford. **Silber-pencilled.**—1, H. Pickles, jun. 2, J. Walker. **CHICKENS.**—1, H. Pickles, jun. 2, J. Preston.

BANTAMS.—Game.—1, 3, and Medal, T. C. & E. Newbit, Epsworth. 2, D. Hunter, Sunderland. *Any other Variety.*—1, J. Preston. 2, D. Hunter.

DUCKS.—Aylesbury.—1, E. Leech. 2, W. Stonehouse, Whithy. *Any other Variety.*—1, E. Leech. 2, C. N. Baker, Chelsea.

SWEETSTAKES.—1, J. P. Fawcett, Whithy. 2, J. S. Booth, Chesterfield.

ANY OTHER VARIETY.—1, G. H. Procter, Durham. 2, Mrs. T. W. Hurd, Stricklandgate, Kendal.

PIGEONS.

CARRIERS.—Cock.—1, H. Yardley, Birmingham. 2, E. Brown, Sheffield. **HEN.**—1, H. Yardley. 2, T. W. Kilburn, Bishop Auckland.

POUTERS.—Cock.—1 and Medal, T. Rale, Gilesgate, Durham. 2, H. Brown, Walkley, Sheffield. **HEN.**—1, H. Brown. 2, H. Cockton, Middlebrough.

TUMBLERS.—Almonds.—1 and Medal, W. B. & H. O. Blenkinsop, Newcastle-upon-Tyne. 2, H. Yardley. *Any Colour.*—1, W. R. & H. O. Blenkinsop. 2, G. J. Taylor, Fartown, Huddersfield.

BARBS.—1, H. Yardley. 2, H. Cawood, Thorne, Doncaster.

OWLS (FOREIGN).—1, J. Fielding, jun., Rochdale. 2, W. R. & H. O. Blenkinsop.

TUMBLERS.—1 and Medal, T. Rale. 2, W. B. Van Haansbergen, Newcastle-upon-Tyne.

FANTAILS.—1, J. F. Loveridge, Newark-on-Trent. 2, H. Yardley.

JACOBIENS.—1, T. Rale. 2, W. B. Van Haansbergen.

TURBITS. 1, R. Youll, Sunderland. 2, T. Rale.

THREE PAIRS.—Medal, T. Rale.

OWLS (ENGLISH), DRAGONS, or ANVERS.—1, T. W. Kilburn. 2, F. Graham, Birkdale. 3, T. Hopper, Langley Moor, Durham.

TUMBLERS (COMMON), MAGPIES, or NONS.—1, W. E. Easton, Hull. 2, T. C. Taylor, Middlebrough. 3, T. G. Hopper, Langley Moor, Durham.

ANY OTHER VARIETY.—1, T. W. Kilburn. 2 and 3, W. Bearpark, Ainderby, Northallerton.

SELLING CLASS.—1, W. R. & H. O. Blenkinsop. 2, J. Irwin, Tanfield, Farnworth. 3, N. St-vobson, Durham.

JUDGES.—Poultry.—Mr. R. Teelby, Fulwood, Preston; *Pigeons.*—Mr. E. Corker, Croydon.

LOWESTOFT POULTRY SHOW.—At this Show, which will be held in January, Game, Dockings, Spanish, Cochins, and Brahmats, have each a cup for the first prize; there are four classes for Hamburgs, with a cup for the best pen; a cup for Bantams; and a point cup for Pigeons. The Committee deserve encouragement for the attention given to the birds, of which those arriving late are always marked in the catalogue

as arriving too late for competition, and catalogues, if requested, are sent by the first post after the awards are made.

GUILDFORD POULTRY SHOW.

We gave last week a report of this Show, but the prize list did not reach us in time for publication.

DORINGS.—Gray.—1, M. Putney. 2, J. Ivory & Son. Chickens—1, Cnp. and prize for best pen of Dorkings, C. Pannell. 2, J. Ivory & Son. 3, M. Putney.
BANTAMS.—1 and 2, F. James. hc, C. Howard & W. J. Nichols. c, C. Mottram.
Ducks.—Aylesbury.—1, Dr. Merriman. 2, A. B. Friend. hc, E. Hilder. Dr. Merriman. c, L. A. Consmaker.
Rouen.—1 and Prize for best pen of Ducks, J. Ivory & Son. 2, J. Pares. hc, E. Burce. M. Putney; J. Ivory & Son; G. Cubitt, M.P. Any other Variety.—1, R. A. C. G. Ansten (Summer Ducks). 2, W. Harzeaves (Call Ducks). hc, J. M. Molyneux (Call Ducks).
GEESE.—1 and Prize for best pen of Geese, E. Hilder. 2, W. Messenger. c, J. Pares; G. Griffin.
Goslings.—1, W. Messenger. 2, E. Hilder. hc, A. B. Friend. G. W. Attlee; J. Pares.
TURKEYS.—1, W. Messenger. 2, J. C. Ramsden. hc, G. W. How; Countess of Lovelace. Poults.—1, W. Messenger. 2, R. Harrison. hc, J. M. Molyneux; Countess of Lovelace; W. S. Smith (2).
ANY OTHER VARIETY.—1 and 2, G. Chilton (Creve-Coeurs). hc, A. B. Friend (Houdans). c, W. Virgo & Son (Houdans).

BARTON AND NORTH LINCOLNSHIRE POULTRY SHOW.

The third exhibition of poultry, Pigeons, singing birds, and Rabbits was held on the 23rd inst., under the most distinguished patronage. There were upwards of 160 entries in the various classes in the live poultry show, and about 80 in the poultry for sale, including poultry dressed ready for the spit. The arrangements were satisfactory, and the Show having proved a success, it is proposed to increase the prizes next year.

GAME.—1, F. Sales, Crowle. 2, J. Ward, Goxhill. Any variety.—1, F. Sales. 2, J. Hogzard, Barton. hc, F. Sales. 2, H. W. Armstrong.
SPANISH.—1, E. Wilson, Cottingham. 2, H. Charlton, Horncastle.
HAMBURGS.—Gold-spangled.—1, R. Robson, Hull. 2, J. Stamp, Barrow. Gold-pencilled.—1, G. W. Robinson. 2, C. Aston, Cottingham. Silver-spangled.—1, Master F. Astley, Elsham Hall. Silver-pencilled.—1 and 2, K. Robson.
BANTAMS.—Game.—1, Master F. Astley. 2, R. Robson. Any variety.—1, Hudson & Burnip, Epworth. 2, W. H. Tomlinson, Newark.
POLANDS.—1 and 2, J. M. Procter, Hull.
DORKINGS.—1, C. S. Britton, Hull.
COCHIN-CHINA.—1, Lovelidge, Cottingham. 2, J. Cross, Appleby.
ANY CROSS BREED.—1, Mrs. Cross.
GEESE.—1, R. Winship. 2, W. Searent.
DUCKS.—Aylesbury.—1, J. Williams, Wath-upon-Deane. 2, C. Simmons, Goxhill. Any variety.—1, Mrs. J. M. Procter. 2, Miss Wright.
TURKEYS.—1, Mrs. F. Bygott. 2, Miss Searent, Barrow.
SELLING CLASS.—2, J. Bilton, Cottingham. Chickens.—1, Lovelidge. 2, J. Bilton.
PIGEONS.—Nuns.—1, T. Waitt, Birmingham. 2, C. N. Lythe, Cottingham. Carriers.—1, J. Hairsine. 2, C. Newbold, Croppers.—2, G. Bruce, Trumpeters.—1 and 2, C. N. Lythe. Fantails.—1, C. N. Lythe. 2, T. Waitt. Any other Variety.—1, Hudson and Burnip. 2, T. Caparn.
CANARIES.—Any variety.—1, A. Lewis. 2, Haverson.
RABBITS.—Lop-eared.—1 and 2, P. Ashton. Any other Variety.—1, T. McLellan. 2, G. Cowper.

JUDGES.—Messrs. E. Newlitt, London House, Epworth; and J. Hodgkinson, Hull.

KIRKCUDBRIGHTSHIRE POULTRY SHOW.

This Society's third annual Show was held on December 16th in the Town Hall, Castle Douglas, a building well adapted for the purpose, and capable of accommodating many more pens. The Show was the best the Society has yet had, and was well supported by visitors, many pens changing hands.

The Game were but poor, but both classes of Dorkings were well represented, more especially the Silver-Greys, both adult and young birds of which were very good. Some of the Brahmas were above the average in size, colour, and marking. In the Selling class, Rouen Ducks were first and Dorkings second. In the Duck classes the Ronens were very good in all points, and the Aylesburries moderately good. In the "Variety" class White Muscovy were first and Brown Decey second. Among the Game Partridges there were some small stylish birds, but of the other kinds little can be said.

Among the Pigeons the Tumblers were good, the winners being Almonds; the Carriers and Pouters of moderate quality, and the Fantails very good. In the "Variety" class Archangels were first and Blue Turbits second.

There was also an excellent display of Gage birds, mostly of the Scotch Fancy Canary; and the Goldfinches were of unusual quality, the white-throated birds being of the rarest excellence.

GAME.—Black Reds.—1, J. Harding, Dumfries. 2, R. Kerr, Barjarg Tower. c, Mrs. G. Matland, Glenochter. Other Reds or Blues.—Chickens.—1, J. Harding. 2, R. Kerr.
DORINGS.—Coloured.—1, Gray, Ingliston. 2 and hc, Mrs. Mackie, Ernespie. Chickens.—1, Mrs. G. Matland. 2 and hc, Mrs. Bell, Hilltown. 3, Thomson, Blaket. c, Mrs. Mackie; N. Wilson, Croys. Silver-Greys.—1, J. Cunningham, Tarbolton. 2, A. Stirling, Croys. hc, Mrs. Hume, Auchendy. 3, Mrs. Congreve, Millbank. c, Mrs. Mackie.
CHICKENS.—1, B. Cunningham, 2, Mrs. Bell. hc, Mrs. Congreve. c, Mrs. Congreve; Mrs. Bell; Thomson.

SPANISH.—1, Mrs. Mackie. hc, M'Adam, Whitepark. Chickens.—1, Mrs. Brown, Arrebban. 2 and c, Mrs. Mackie.
COCHIN-CHINA (any colour).—Prize, Mrs. Knott, Dumfries. Chickens.—1, J. R. Storey, Millhead. 2, Mrs. Mackie (Buff). hc, Mrs. Mackie (Cinnamon); J. Thorpe.
HAMBURGS.—Golden-spangled.—Chickens.—1, Mrs. G. Matland. Silver-spangled.—1, J. Gibson. 2, R. Kerr. Chickens.—1, J. Gibson. 2, Mrs. Brown. hc, G. Pitt. Golden-pencilled.—2, Miss M. Loan, Hilltown. Chickens.—1, J. Gibson. Silver-pencilled.—Chickens.—1 and 2, Mrs. Hume.
BRAHMA POOTRAS.—1, Miss A. Stewart, Edinburgh. 2, Mrs. Congreve. Chickens.—1 and 2, Miss A. Stewart. hc, Mrs. G. Matland. c, Mrs. Congreve.
BANTAMS.—Golden and Silver-laced.—1, K. Bryden. Black.—2, R. Hughes. B. G. 1 and 2, J. Gibson. hc, J. Morrison.
GAGE BIRDS.—Black or other Reds.—1, 2, and etc. —Fotheringham. hc, J. Little. c, Thomson. Duckings and other breeds.—1, N. Wilson. 2, T. Ross, Auchendy. c, W. Little. T. Conchar, Castle Douglas.
ANY VARIETY.—1, N. Wilson (Houdans). 2, Miss Knott, Dumfries (Golden Poland). hc, Mrs. Hume (Houdans).
SELLING CLASS.—1 and 2, Thomson (Dorkings and Rouen Ducks). hc, Fotheringham (Spotted). 3, Mrs. Congreve (Dorkings); J. Cunningham (Dorkings). c, J. Shaw.
DUCKS.—Aylesbury. 1, Mrs. Brown. 2, General Johnston. hc, Fotheringham (2); Mrs. Carson, Mochrum. c, General Johnston; Mrs. Carson. Rouen.—1 and etc. —Thomson. 2, Gray. hc, Gray; Mrs. G. Matland; J. R. Storey. c, Gray; Mrs. Hume; Mrs. Congreve. Any other Variety.—1, W. Lottimer. 2, Mrs. Marchbank (Wild). hc, A. Muir (Muscovy).
GEESE (any variety).—1, Gray. c, Mrs. Laurie, Glenrobin.
TURKEYS.—Black Norfolk.—1, Mrs. Maxwell, Munches. c, M'Adam. Any other Variety.—1, Mrs. Mackie. 2, R. Carson, Milton Mill. hc, Mrs. Hume; Mrs. Congreve (2).

PIGEONS.

TUMBLERS.—1, J. Thorpe. 2 and hc, J. Turner. c, J. Arnott, Dumfries.
CARRIERS.—1 and 2, J. Thorpe. c, Miss Knott.
PUTERS.—1 and hc, Mrs. Mackie.
JACOBS.—1, Miss Knott. 2, J. R. Storey.
FANTAILS.—1 and 2, T. Douglas, Thornhill. hc, Miss Knott; T. Douglas. c, J. R. Storey (2).
ANY OTHER VARIETY.—1 and 2, Miss Knott (Turbits and Archangels). hc, A. Skirving (Turtle Doves); J. Turner (Owl); T. Douglas (Owl). c, Mrs. Mackie.

CANARIES.

LOCAL CLASSES.

YELLOW.—Cock.—1, A. Dobie, Castle Douglas. 2, J. Pearson, Castle Douglas. c, G. Black, Castle Douglas. Hen.—1, A. Martin, Castle Douglas. 2, John Scott, Castle Douglas. c, James Scott, Castle Douglas.
BUFF.—Cock.—1 and c, A. Martin. 2, J. Pearson. Hen.—1 and c, J. Shaw, Castle Douglas. 2, J. Pearson.
YELLOW PHEAL.—Cock.—1, W. Hamilton, Castle Douglas. 2 and c, W. E. Ham, Castle Douglas. Hen.—1, A. Martin. 2, W. Eaglesham. c, J. Shaw.
BUFF PHEAL.—Cock.—1, J. Shaw. 2, A. Martin. c, W. Hamilton. Hen.—1, A. Martin. 2 and c, W. Eaglesham.
GREEN.—Cock.—1, J. Shaw. 2, G. Maxwell, Castle Douglas.

OPEN CLASSES.

YELLOW.—Cock.—1, J. Thorpe, Dumfries. 2, R. Bryden, Lochmaben. c, A. Dobie. Hen.—1, J. Thorpe. 2, A. Martin. c, J. McQuhae, Maxwelltown.
BUFF.—Cock.—1, J. Thorpe. 2 and 3, A. Martin. c, John Scott. Hen.—1, J. Thorpe. 2, J. Shaw. 3, J. McQuhae.
YELLOW PHEAL.—Cock.—1, J. Thorpe. 2, R. Bryden. 3, W. Eaglesham. c, J. McFie, Springholm; J. Pocher, Southwick. Hen.—1, J. Shaw. 2, J. Pocher. c, R. Bryden; W. Eaglesham.
BUFF PHEAL.—Cock.—1, R. Edgar. 2, J. Shaw. 3, Mrs. Mackie. c, R. Bryden. Hen.—1 and 2, R. Bryden. c, Mrs. Mackie.
GOLDFINCH MULES.—1, A. Milroy, Newabbey. 2, J. Hume, Castle Douglas. c, J. McFie.
GOLDFINCHES.—1 and 2, A. Martin. 3, T. M'Taggart, Castle Douglas. c, J. Ireland, Castle Douglas.

PARROTS (any colour).—1, Miss Jardine, Castle Douglas. hc, J. Stewart.
FOREIGN BIRD.—1, A. Blyth. hc, Scott.
Mr. E. Hutton, Pudsey, judged the poultry and Pigeons.

HECKMONDWIKE POULTRY SHOW.

The following are the awards made at this Show, held on the 26th inst.:

GAME.—Black-breasted.—1, W. Fell, Adwalton. 2, J. Hodgson, Bradford. Brown Red.—1, W. Fell. 2, H. Beauland, Westgate Hill, Bradford. Duckwing.—1, S. H. and C. W. Mason, Drighlington. 2, W. Fell. White or Pile.—1 and 2, S. H. and W. C. Mason. Black or Brassy Wing.—1, J. Clayton, Gomersal. 2, J. Brook, Gomersal.
COCHIN-CHINA.—1, G. Wright, Cleckheaton. 2, H. Firth, Bradford. BRAHMA-POOTRA.—1, H. Butler, Bradford. 2, W. Firth, Burkeshaw. HAMBURGS.—Gold and Silver-spangled.—1, S. Smith. 2, H. Firth. Gold and Silver-pencilled.—1, S. Smith. 2, W. Jagger, Horbury. Black.—1, E. Hopkinson, Bradford. Any other variety.—1, H. Bowker, Keighley. 2, J. Powell, Bradford.
ANY BRED.—Cock.—1, B. Constantine, Littleborough. 2, W. Fawcett, Heckmondwike. Hen.—1, B. Constantine. 2, H. Beauland.
BANTAMS.—Red Game.—1, S. Smith. 2, G. Noble, Staincliffe. Duckwing Game.—1, T. Marsdon. 2, T. Dyson, Halifax.
PIGEONS.—Carriers.—1 and 2, B. Constantine. Antheers.—1, W. Firth. 2, J. A. Collinson, Halifax. Owls.—1, J. W. Watson, Bradford. Dragoons.—1, J. Schofield, Cleckheaton. 2, B. Barrill, Cleckheaton.

FALKIRK POULTRY SHOW.

The second Show of the Falkirk Association was held in the Corn Exchange on the 24th inst. The weather being the most severe that has been experienced for several years, it was a great drawback to birds that had to travel long distances, although on arrival they were well fed and cared for, and the building was very comfortable. Great credit is due to Mr. Roberts, the Honorary Secretary, for the attention paid to the specimens. The pens employed were Turner's, and, as usual, they were very satisfactory.

Adult Spanish were of moderate quality, but the young birds were of rare excellence. The cockerel in the first-prize pen, shown by a local exhibitor, was quite equal to anything we have seen this season. The adult Dorkings were also of fair quality, although some of the birds were bad in feet, and others had frosted combs. Dark-coloured were first, and Silver-Greys second and third. Of young Dorkings there were twenty-eight entries, and they were a very fine lot. In ad-

dition to three prizes and several high commendations the whole class was commended. Dark-coloured were here also first, and the others Silver-Greys; altogether the class was such as is rarely seen. *Cochins* were but moderate, the *Brahmas* little better, and the *Scottish Greys* not numerous, but of fair colour and marking. Of Gold-spangled *Hamburghs* there were twenty-two pens, and the class was good. The first-prize pen, to which the cup for the best pen in the Show was also awarded, was nearly perfection. The second pen was also good, and consisted of adult birds. The third-prize pen contained one of the most perfect cockerels ever seen; this pen only losing owing to the pullet being a little smaller in marks than the others. There were also twenty-two pens of Golden-pencilled *Hamburghs*, but with the exception of the three winning pens they were but poor. There was no class for Silver-pencilled. The Silver-spangled were not so good as we expected to see, with the exception of the prize-winners.

Of *Game* fowls there were some good birds, but several were badly matched; the first prize went to Black Reds, and the second to Duck-wings. The best pen in the Show was left out on account of the hen being swollen in the face, and another that would doubtless have appeared in the prize list was disqualified, having had the feathers trimmed.

In the "Any other variety" class, Mr. Pickles won with a fine pen of Silver *Polands*; the second being *Crève-Cœurs*, the third *Hondans*. The *Aylesbury Ducks* were tolerably good, but the *Rouens* were not at all such as we expected to find, and a nice pen of *Carolinas* was awarded the first prize against them. The *Turkeys* were mostly of the Norfolk variety, and were the best display of that kind we have ever seen, the size and colour being first-rate.

Game Bantams had thirty-four entries, and many of the birds were very good specimens. The first-prize pair were the best *Brown Reds* we have seen. The second and third-prize birds were *Black Reds*. Of the other varieties of *Bantams*, *Black Reds* were first and third, and *Solbrights* second. The Selling class presented a great attraction to buyers, the birds being uniformly good, and at the low price of £1 per pen. *Crève-Cœurs* were first, and *Dorkings* second and third.

In the *Pigeon* department there were but five classes, *Pouters* having the first position. *Blues* of good length and style were first; *Blacks* capital in colour and length, but rather thick in girth, second; and *Whites* of good properties third. The *Fantails* were very good in tail and carriage, but the *Jacobins* were not first-rate. Of *Tumblers*, a neat pair of *Yellow Mottles* were first, and *Almonds* second and third. In the "Variety" class *Letz* were first, *Red Turbites* second, and *Black Carriers* third. The remaining birds of this class were also good. The Show was well attended, and we think a great success.

SPANISH.—1, R. Somerville, Edinburgh. 2, W. Dickson, Slamanan. 3, R. Dickie, Alva. *hc*, J. W. Will, Errol. *c*, D. Duncan, Carron. *Chickens*—1 and 2, Lechl, W. G. Hardie, Carron. 2, W. Dickson. 3, A. Robertson, Townholm. *Kilmurck*. *hc*, A. McDonald, Easter Moffat, Airdrie. *hc*, E. Symon, Errol. *c*, W. R. Farquhar, Barrehead; D. Gollady, Meikle; R. Somerville.

DORKINGS.—1, D. Gollady, Meikle. 2, A. McDonald. 3, J. Malcolm, Langton. *hc*, M. Edwards, Hillon, Alloa. 2, W. Hays, Barrehead; G. Gordon, Errol; A. Carswell, Stenhousemuir. 3, W. Weir, Inches Farm. *Chickens*—1, T. Raines, Stirling. 2, Z. W. Heya. 3, J. Malcolm, Langton. *hc*, P. Gray, Tolly Well, Winchburgh. *hc*, D. Gollady; D. Duncan; W. Weir; W. Forbes; J. Turnbull, Carnock; A. McDonald.

COCHIN-CHINA.—1, Pollock, Busby. 2 and 3, A. Campbell, Larigs. *hc*, H. Paton, Larigs. *hc*, J. Brown, jun., Craigmill, Stirling. *c*, A. T. Williamson, Grangemouth; Com. G. F. Lyon, Kirkmichael, Dumfries.

BRADMA POOTRAS.—1, J. W. Morrison, Kirkcaldy. 2 and 3, T. Raines. 3, A. Robertson. *hc*, Miss Liddell, Edinburgh. *hc*, R. Brownlie, Kirkcaldy; W. R. Farquhar.

SCOTCH GAYS.—1 and 2, W. Gibb, Arndale. 3, T. Laurie, Linlithgow. *hc*, A. Binnie, Glasgow.

HAMBURGH *Golden-spangled*.—1 and Cup, J. W. Will. 2, H. Pickles, jun., Earby, Skip-on. 3, H. M'Nab, Barrehead. *hc*, A. Robertson. *hc*, S. & R. Ashton, Mottam; R. Dickson; A. Robertson. *c*, J. F. Loversidge, Newark-on-Trent; J. Hulburn, Stewarton, Ayrshire. *Golden-pencilled*.—1, A. Crosbie, Melrose. 2, H. Pickles, jun. 3, J. W. Will. *hc*, Dr. J. D'ulop, Clackmannan. *c*, Mrs. Harvey, Edinburgh. *Silver-spangled*.—1, J. Stewart, South Arthurie, Barrehead. 2, H. Pickles, jun. 3, S. & R. Ashton. *c*, D. Forrester, Woodcockdale, Linlithgow; J. W. Will.

GAME.—1, D. Duncan. 2, D. Harley, Edinburgh. 3, W. Chambers, Leslie, Fife. *hc*, J. W. Will; A. White, Camp, Motherwell; A. Hutchison, Grahamston Avenue. *c*, J. Logan, Carnwath; D. Harley; J. W. Blakey, Stirling.

ANY OTHER VARIETY.—1, H. Pickles, jun. (*Silver Poland*). 2 and 3, J. Logan (*Hondan and Crève-Cœur*). *hc*, D. Drazer, jun. (*Poland*). *hc*, A. Crosbie; J. Logan (*Black Hamburg*). *c*, J. Partington.

DUCKS.—*Aylesbury*.—1, J. W. Will. 2, R. Dickie, Alva. 3, A. Robertson. *hc*, D. Gollady, Meikle; J. T. Bell, Easter Batarvie, Canar Fife; A. Robertson; J. Logan. *c*, J. W. Will. *Any other Variety*.—1, S. & R. Ashton (*Carolina*). 2, A. Robertson (*Ronen*). 3, J. Harper, Blairlogie (*Ronen*). *hc*, J. Logan (*Ronen*). *hc*, J. Wilson, Linlithgow (*Ronen*); Com. G. F. Lyon.

TURKEYS (Any variety).—1 and 2, J. Wilson. 3, W. Forbes. *hc*, J. Logan. *c*, J. Turnbull, Carnock; W. Forbes.

BANTAMS—*Game*.—1, J. W. Will. 2, T. Raines. 3, D. Forrester, Woodcockdale. *hc*, Mrs. W. Stewart, Springfield, Barrehead. *hc*, R. Brownlie; R. Paterson. *c*, Melrose; A. Campbell; W. Dickson; W. Chesne, Salsburgh; D. Harvey. *c*, Main, Camelon; T. Raines; J. W. Will; J. Waidell, Airdrie. *Any Variety*.—1, S. & R. Ashton (*Black*). 2, J. G. Orr, Beith (*Gold-laced*). 3, H. Pickles, jun. (*Black*). *hc*, A. Frew, Sinclairton (*Silver-laced*); J. W. Will (*Black*). *hc*, J. G. Orr (*Silver-laced*); J. Archibald, Earlstone, Berwick (*Japanese*); A. Mitchell, Paisley (*Black*).

SELLING CLASS (Any variety).—1, W. Linton, Selkirk (*Crève-Cœur*). 2, S. Bell, Castleton, Fife (*Dorkings*). 3, J. M. Leach, Langs, Dorkings. *hc*, W. G. McDonald, Pitthead, Errol (*Dorkings*). *hc*, J. Turnbull, Carnock (*Dorkings*). D. Gollady, Meikle (*Dorkings*); R. Murdoch, Kilmilly (*Dorkings*); J. Williamson, Oxgangs (*Buff Cochins*); W. Dickson (*Game*); A. T. Williamson, Grangemouth (*Dorkings*); H. Pickles, jun. (*Polands*); Com. G. F. Lyon, Kirkmichael (*Dorkings, Brahmas, and Hondans*) (3). *c*, A. McDonald (*White Dorkings*); R. Dickie, Alva (*Spanish*); R. Murdoch (*Spanish*).

PIGEONS.

POOTRAS.—1 and 2, J. Mitchell, Glasgow. 3, J. Morrison, Morningside, Edinburgh. *hc*, A. Wright, Morningside, Edinburgh; J. Mitchell. *hc*, W. Moon, Edinburgh; J. Mair, Kilmarnock; A. Wright.

FANTAILS.—1, J. Mair. 2, A. Crosbie, Gattonside, Melrose. 3, W. C. Hardy, Carron. *hc*, J. G. Spence, Edinburgh; E. Hope, Kirkcaldy; R. Frew.

JACOBINS.—1 and *hc*, G. J. Spence. 2, R. Paterson. 3, Mrs. R. Frew. *c*, A. Johnstone.

TUMBLERS (Any variety).—1, J. Bruce, Dunfermline. 2, J. Mair. 3, A. Johnstone, Bathgate. *hc*, W. Elliot, Musselburgh; F. D. Wood, Edinburgh.

ANY OTHER VARIETY.—1, A. Crosbie. 2, R. Inch, Edinburgh. 3, J. Mair. *hc*, G. Forrest; R. Paterson; A. Johnstone.

JUDGE.—Mr. E. Hatton, Padsey, Leeds.

BINGLEY PIGEON SHOW.

(From a Correspondent.)

THERE was no Committee, the whole being entirely in the hands of Messrs. Beldon and Hawley, whose spirited attempt was well rewarded by one of the best displays of *Pigeons* seen in Yorkshire for some time. Turner's pens were used, and altogether the arrangements were good, and the birds cleaned, fed, and supplied with water in a most exemplary manner, but it is our unpleasant duty to record the fact that the public failed to appreciate the efforts of the proprietors of the Exhibition.

Ten *Pouter* cocks were brought together, the first-prize bird, a fine *White*, was well placed, and claimed at once, at the low price of £5. The first-prize hen was *Red*, and the second *Blae*, the latter very small and poor, the *Yellow* hen shown by Mr. Harvey and the *White* one by Mr. Sharp being in all respects superior. The cup for *Pouters* would have been much better given to the first-prize *White* cock than the *Red* hen to which it was awarded. There were some very good *Carrier* cocks both in eye and wattle, but the hens were rather a coarse lot, with the exception of the *Black* one, to which was given the cup offered for the best *Carrier* hen, or pair of *Short-faced Tumblers*. In *Almonds*, the first-prize birds were not so good in form and skull as the second-prize birds, but were better in ground colour, though the right eye of the cock was of a dark shade. For *Barbs*, foreign *Owls*, and *Jacobins*, there was also a cup offered, and this was won by Mr. Firth with a very fine pair of *Black Barbs*. Foreign *Owls* were badly placed, the second-prize birds being much smaller than the first, and much shorter and rounder in head; and the first-prize cock showed signs of romp. Both pairs were white. Of *Jacobins*, the best pair was left out—they were *Red*—no other pen approaching them in size, colour, and quality. The reason assigned for this was, that they were a little foul on the end of the flight feathers, although the first-prize birds were quite as bad in that respect. The *Trumpeters* were a grand lot; the first prize was awarded to *Light-mottled*, and the second to *Black*. In *Turbits*, *Reds* were first, but although good they were not strictly a match in colour. The second were very near *Blues*, and several other pairs might have been justly noticed.

There were twenty-eight entries for *Dragons*, the first-prize pair winning the cup against *Trumpeters* and *Turbits*; but this was considered the grand mistake of the Show, as the class contained some most extraordinary pairs, and with the exception of colour (*Yellow*), the first-prize birds were very bad. In the first place, the head and beak of the cock were coarse and curved, and he had pearl eyes, while the hen was straight in head and very flat on the skull, and she had red eyes. The best pair in the Show, belonging to Mr. Waddington, were dark *Blues*, and as nearly faultless as they can be bred.

There was a cup also for the best *Fantails*, *English Owls*, or *Antwerps*, and awarded very justly to the first-named variety, which class was very well represented.

In *English Owls* there has been great improvement, the birds coming up to the old standard, and there is no doubt that great difficulty was experienced in making the awards in this class. Of *Antwerps*, there were thirty-one entries. *Short-faces* winning both prizes, and both pairs were good. It would be well if these birds could be divided into two classes, of *Long* and *Short-faced* varieties.

The cup for the remaining classes was won by a very perfect pair of common *Red Mottle Tumblers*, the best we have seen, though the second-prize pair in the same class was little inferior to the former.

In the "Variety" class, *Ice Pigeons* won both the prizes, although we thought a pair of *Black Swallows* might have been given a position. The Selling class was well filled, and the restricted price being 50s., and the birds good, many lots were sold, though the first-prize pair of *Barbs* in that class had not presented many promising features.

We published the prize list and names of the Judges last week.

MY LIVE PETS.

THERE is no denying I am a lover of pets. My first pet (I cannot remember the darling) was a toad, which lived in the hollow of a fine old oak tree on the lawn. At that time my age was two-and-a-half, and I have been told that I daily used to toddle forth with a spoonful of my morning's bread and milk to feed "my dear pitty toad." I have seen the fine old tree, and the hollow in it, since I have been of more mature age, but not the toad; though I confess to still thinking both frogs and toads very beautiful in many respects, and very much maligned in many more.

Then came a tame *Jackdaw*, the delight of all our hearts. He regaled our affection by pecking our little bare legs just above the socks, and stealing our small treasures from the nursery play-box. On one occasion having watched us gather some blue hyacinths, and draw a plateful of long, red, tender radishes, he stealthily followed in our

wake, snapped off every hycynth he could reach, and pulled the green tops off all the radishes in the bed. On another occasion he was discovered, perched on the study table, a pen in his beak, with which, after dipping it into the inkstand, he deliberately scrawled over the pages of all the books lying open around him. The inky meanderings of his pen remain to this day to testify against him. I think poor "Jacky" finished his exploit by drowning himself in a "beck" which flowed at the bottom of the garden.

At this period I have a lively remembrance of the intense pleasure I took in watching the bees at their work amongst the flowers. We used to catch them in the bells of the Foxglove, carry them in their pretty little prisons to the greenhouse door, and let them in through the keyhole to fructify the blossoms of the melon and cucumber plants—not that we then knew why they were wanted in the greenhouse, but we were none the less proud when we had successfully escorted a captive thither.

As far as I remember the favourites which followed "Jacky" were a pair of pretty Wood Pigeons. The chief thing to be recorded of them, or rather of one of them, is that he or she pecked a thimble off my finger one day when I was feeding them, and swallowed it bodily. A poor frightened child I was then, I felt sure my dear Dove would die, and kept it shut up in its cage for days; but never a bit the worse was "Dovey." What became of the thimble I know not, nor can I recollect what eventually became of my Pigeons.

To these succeeded Rabbits, and a tame Hawk; the latter a most exigent pet, for he required a poor little bird to be sacrificed to him almost daily; but he was really tame, and truly affectionate, and on the sad day when "the children" were all dispatched to school, the poor Hawk screeched so incessantly and so discordantly he had to be given away.

Two dear little Hares came next, they were found by the mowers when cutting the hay, and were tiny Hares indeed—both could sit comfortably together in the palm of my hand. The men brought them to the rectory saying, "If anybody can keep 'em alive 'tis Miss Jemima." Never were two prettier little pets, or two prettier great pets when they grew up, for grow up they did. At first they were kept in "Miss Jemima's" bedroom, and fed on warm milk out of a bottle with a quill in the cork of it. The bottle was always deposited under my pillow when I went to bed, and "Tiny" and "Beas" tucked up comfortably in a basket of wool in a corner of the room. At early dawn, mindful of my nurslings, I invariably awoke, and putting my hand out of bed found the little creatures as near as ever they could get to me, close to the vallance of the bedstead. It was pretty to see them running after me about the house and garden, and had it not been for the domestic dogs and cats they would always have been at liberty. They grew and thrived, and soon ate bread and grass and clover, and all that hares ought to eat, but they never lost their love for milk, nor for their foster-mother.

I must pass over many other favourites, and come to the present family pets; not to speak of two beautiful, silky black and tan spaniels, almost human in their intelligence, and more than human in their obedience, unvarying affection, and wonderful noses, and an old grey tom cat, of whom much could be said. There are two tortoises, named Diogenes and Ulysses, who have the full range of a large un-walled garden, but who have never left its precincts, though naturally Ulysses is the more addicted to wandering. Their habits are very singular, and well worth watching, and they are decidedly far less shy and retiring than they were; they now do not object to dining in public, and Diogenes has a newly-acquired trick of giving a loud hiss, if taken up suddenly, or turned upside down; I presume it is expressive of his wrath and disapprobation. At the present time they have both hidden themselves, we know not where, for their winter snooze, and we shall probably see nothing more of them till April or May.

There is also a cage full of Canaries, and my last pet fact is connected with my birdies. A prisoner to the sofa for many months, owing to an accident, one of my chief interests was a pair of Canaries building their first nest. In due time four pretty blue-grey eggs, spotted with brown at one end, were deposited therein, and one morning, all a fortnight after the last was laid, I heard to my great delight a faint "chip" "chip" from the cage, and knew that the chicks were hatched. But alas! two days afterwards the cage fell down, the mother bird and her babies were jolted out of the nest, and either from some injury, or, as I believe from fright, the gentle little mother died in a few hours. The grief the loss occasioned need not be dwelt upon; carefully the nestlings were replaced in the nest, and I fondly hoped the cock bird, a most attentive husband and father, would bring up the children. He did his best—he fed them assiduously, but had no notion of "gathering them under his wing" so, though I covered them with wool as soon as they had had their last evening meal, before morning two were dead, and the third dying of cold. The poor little naked survivor I kept in my hand expecting momentarily it would die too, but by-and-by a faint piping was audible, which gradually grew louder and stronger. The warmth had revived "the motherless bairn," and it wanted its breakfast. It soon had some, and for the benefit of such of your readers as may be placed in similar circumstances, I will describe exactly what its food was:—An egg boiled quite hard and crumbled to powder, a little white well-baked bread grated fine, some scaled rape seed pounded, and as many of the black skins as possible picked out, a mashed lettuce, groundsel, or watercress leaf.

With this mixture my chick was fed for weeks; I put a little of it in

the palm of my hand and mashed it well together with half a drop of warm water. I then took a quill cut exactly like a pen, minus the slit, in one hand (having filled it with the food), and a wooden match in the other, and when the little mouth gaped open I put the quill quite down the throat, and pushed off the food with the stick; it was eagerly swallowed and more gaped for. I found by its pipings that the baby required to be fed every hour; at first two quills full satisfied it, and afterwards it devoured three or four at a meal.

I cannot say my child was pretty at first, but when fledged it was a fair, pure yellow Canary, and received the name of Fairy. I need not say my birdie was tame—it was more than tame, it slept in a tiny wadded basket by my side at night, and nestled on my pillow or shoulder by day. When Fairy was five weeks old, I went with a sister to a pretty seaside village eight miles distant; Fairy of course went too, but alas! and alas! one Sunday morning, when, as usual, it was perched on the pillow of my sofa, the room, and the house door being open, it floated a pretty brown butterfly, and off Fairy flew after it. The butterfly floated out again into the sunshine, with Fairy still in attendance. All day long the whole of the village, who had learned to love the tame birdie, were roaming the lanes and fields; many times the lost pet was seen skimming the blue sky, darting with the Swallows round the old ruined castle, or lighting on a chimney or housetop, but never near enough to be caught. It would perhaps be more faithful than wise to confess that a good many tears were shed while Fairy was thus enjoying herself.

At last all hopes were given up, and evening was closing in, when down came the fair little birdie, and lighted on its forlorn mistress's shoulder, and kissed her as if nothing had happened. Fairy has never had another out-of-door flight, but she has travelled a great deal for a bird, and brought up many dozen children of her own—brown, spotted, golden, and white—but none so cherished nor so tame as our pet Fairy.—C. J. S.

THE FLYING TUMBLER.

THE Flying Tumbler is the most general favourite fancy Pigeon. Its easy propagation and generally sound constitution render it most suitable to a young fancier; it soon establishes a hold upon his regard, which would not be the case, probably, with the more highly-cultivated breeds, which require more knowledge and care to breed and keep in health. Another recommendation is its low price, for every boy can raise sufficient money for the purchase of a pair of Tumblers, and we have no hesitation in saying that more true and staunch fanciers have begun with Tumblers than any, perhaps all, other varieties.

We may also claim as ancient a pedigree for the Flying Tumbler as for any of his high-born cousins, for the earliest writers were familiar with it, and record its amusing and merry habits, and how its more studious and intelligent admirers originated his varied plumage, and laid the foundation of that most exquisite and much-admired gem, the Almond of the present day.

The *Baldpate*, *Beard*, *Black*, *Red*, and *Yellow Mottles* of the old fanciers have still numerous admirers, although, as a rule, feather has been greatly neglected of late by the Flying fanciers. A few who combine a taste for feather with flying have taken the class of Tumblers represented by the engraving, and by care and perseverance have produced a few samples that possess some amount of merit. They are great favourites in and about Birmingham, and are as various in colour as the clear-legged birds, *Black* and *Red Mottles* or *Rosewings*, *Red-breasted*, *White-sides*, and *Yellow Whole-feather* among the dark-winged ones. The white-winged are divided into *Saddles* and *Badges*; and there are *Black*, *Blue*, and *Red Saddles*; *Black*, *Blue*, *Red*, and *Bronze Badges*.

They are free-flyers, and most of them rollers, mad or very sharp tumblers if they are allowed to fly; but it is seldom the best-feathered birds are trusted to the many casualties attending flying in a large town like Birmingham.

The original of the engraving was selected as the standard for the *Dark* or *Rose-winged* birds—*Mottles*—that is, the marking on the pinion should form or resemble a rose; there should not be any white elsewhere. The *Red-breasted White-sided* birds should be red all through the short and long flights, tail, and the whole of the body; the whole of the side or pinion *white*. The *Black* and *Blue Saddles* should be dark on the whole of the body down to the hocks, the muffs from the hocks to the toes' end *white*; the head should be evenly sprinkled or *badged*, the throat *bearded*, and for half an inch up the nose the width of the wattle also *white*; the back *saddle* marked as the *Magpie*. The *Red Saddle* the same as *Blue* and *Black*, with the exception of a *white* tail. The *Black*, *Blue*, and *Bronze Badges* should be marked on the head as the *Saddles*, the whole of the bird dark elsewhere, except the muffs

from the hocks and the ten long flights, which must be all white. The *Red*, again, must have a white tail, but in neither case must the white extend up the rump or under the belly. There is no established limit to the length of muffs; the majority favour a medium length—that is, from $1\frac{1}{2}$ inch to $2\frac{1}{2}$ inches; we have seen them $4\frac{1}{2}$ inches, which, to our taste, is excessive, and an impediment to the bird in walking.

Many credit the Dutch with the introduction of the *muffs* on Tumblers, but if they are correct in that statement, and correctly describe the Dutch Tumbler, we can simply say we have

done with that, as with many other foreign introductions, improved upon it.

Our taste requires a Tumbler to be a short, compact bird, and we for long thought it was the only shape that could tumble well, but we are now called to alter our opinion. Our late Secretary (Mr. Noyé) has forwarded from Turkey many specimens of new varieties, and amongst them a pair of *Rollers*, that would lead us to think the tumbling habit could be developed in almost any variety of Pigeon, so different are they to any Tumblers we ever saw. They are of a glossy black

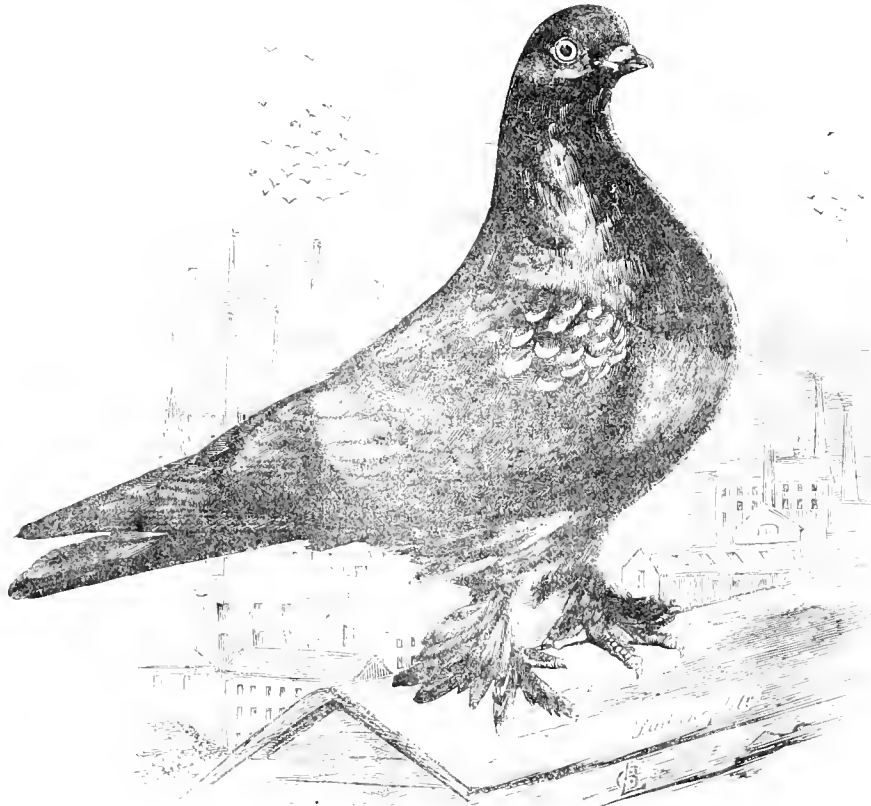

plumage, like the Rook or Raven, long beak, long narrow head, neck slightly curved, excessively long flights and tail, the latter composed of sixteen feathers, rising a little like the Fantail, the legs short in hand. They are not so large as our muffed birds. They appear as though they could do as our friend has often told us they do—viz., “fly for nearly a day.” We are anxious to try their young; we shall not venture to try those we have.

The management of the Flying Tumbler has been so often

published we need say but little on that point; we will simply say, Keep your pen clean, give fresh water every day, plenty of old grey peas, old vetches, English wheat, and good sound barley. If you give any Indian wheat, do not do so either at the moulting season or to rear your young. Fly once a-day in the winter if the weather is favourable, and twice a-day in the summer—a means of keeping your birds healthy and up to their work.—BIRMINGHAM COLUMBARIAN SOCIETY.

AN AMERICAN REMEDY FOR FOUL BROOD.

I PROMISED to report how my refrigerator wintered its colony. The frames were covered with a piece of old carpeting, and the whole space outside the inner hive packed with straw and shavings. This spring it was in splendid condition, and it was found necessary to remove brood and cut out queen cells as early as the 20th of May; and for this locality the surplus would have been large if I had not been obliged to break up the colony on account of foul brood.

You can imagine my disappointment when my apiarian friend, Mr. Sweet, of West Mansfield, pointed out to me this loathsome disease in my choicest Italian colony early in June, when up to that time I had supposed that everything was prosperous with my twelve colonies. After a thorough examination I found six hives more or less affected, and, according to high authority, should be condemned to death. The other six appeared free from disease at this time, although three more subsequently became diseased.

This is my second summer of bee-keeping, and all the duties

pertaining to an apiary were entered into with the enthusiasm and—shall I confess it?—the ignorance and carelessness of a novice. Yes, ignorance and culpable carelessness, for in gathering empty combs from various quarters the disease was introduced, and spread among my pets. One hive in particular, of empty comb, had the peculiar odour, perforated cells, and brown viscid fluid, with which I have since become so familiar this summer; and it seems unaccountable to me how any person, with the *Bee Journal* wide open and Quinby's instructions before him, could be so careless as to give such combs to his bees.

But such was the fact, and foul brood spreading right and left. What shall be done to get rid of it? Shall Quinby be followed—purify the hive and honey by scalding, and treat the colony as a new swarm? or shall the heroic treatment of Alley be adopted—bury or burn bees and hive, combs and all? The latter has sent me some fine queens, but the former has always given reliable advice, and I shall follow his instructions

with two colonies which are past all cure, and reserve the others for treatment, hoping that I may find some cure, or at least palliative for the disease, and add my mite of experience, and, perhaps, useful knowledge to our *Bee Journal*.

Accordingly, June 8th, the combs of the two condemned colonies were melted into wax, the honey drained over and scalded, and the bees, after a confinement of forty hours, were treated like new swarms, and now, September 18th, are perfectly healthy and in fine condition for winter.

I will not occupy your valuable space with all the details of my experiments and fights (which lasted through three months), with the trials of doses of different strengths and kinds, with old comb and new, with young queens and old ones, and with no queen at all, and how in doing this I was obliged to keep up the strength of the colony for fear of robbers and of spreading the disease to my neighbours. Suffice it to say that after two months I had made no apparent headway, although still determined to "fight it out on this line, if it took all summer" and my last hive. In fact, I devoted my apiary to the study of this disease, and perhaps death.

Starting with and holding to the theory that foul brood is contagious only by the diffusion of living germs of feeble vitality (and I was strengthened in my conjecture in microscopical examinations, by finding the dead larvæ filled with nucleated cells), I determined to try those remedies which have the power of destroying the vitality of these destructive germs, these living organisms, and no remedies seemed to me more potent than carbolic acid and hyposulphate of soda. At first I used both, making one application of each, with an interval of one day, and with apparent benefit; but attributing the improvement to the more powerful of the two, I abandoned the hyposulphate and used the carbolic acid alone; and I was so infatuated with the idea of its superiority, that I did not give it up until three of the four hives had become so hopelessly diseased that the combs were destroyed, and the colonies treated to new combs (as it was late in the season), and freely fed with sugar and water. These are now in good condition for winter.

The fourth hive was carried away, the queen caged, and the colony strengthened with a medium-sized second swarm. After all the brood which was advanced had left the cells, I transferred the colony to a clean hive, thoroughly sulphured the old hive with burning sulphur, and stored it away in a safe place for future experiments. I now thought my apiary free from the pest, but on thoroughly examining the whole three new cases of foul brood were found—one very badly affected, and two slightly so, with, perhaps, twenty to forty cells diseased and perforated.

This was about the 1st of August, and again hyposulphate of soda was selected for the trial, and from the first application I have had the disease under control. Three days ago I examined the three colonies thoroughly, and found no new cells diseased in the two which had been the least affected, and in the almost hopelessly diseased one (as much diseased, in fact, as any of those that I destroyed) an entire brood had been raised, with not over fifty or sixty diseased and perforated cells, with dead larvæ remaining, most on one comb, and nearly all the cells contained a new supply of eggs; this colony is certainly convalescent, and I think now, from the recent and second application of the hyposulphate of soda, is entirely cured. Still, I should not be surprised to find two or three or even more perforated cells after this second crop of brood has hatched, as the whole hive, honey, and comb, had been for so long a time so thoroughly saturated with the disease, and at least two-thirds of the cells had, before the medicine was used, been filled with putrid larvæ. If so, I shall treat it to a third dose.

Now, Mr. Editor, as it is frequently of as much practical importance to tell how to administer a remedy as it is to know its name, I will ask your indulgence a little longer, hoping that others may improve upon my remedy, or, at least, test it, if they are so unfortunately ignorant and careless as I was in bringing "the wolf home to the fold."

The solution of hyposulphate of soda which I need was 1 oz. to half a pint of rain water. With this I thoroughly washed out every diseased cell with an atomiser, after opening the cap, also spraying over the whole of the combs and the inside of the hive. The instrument I use is a spray-producer, invented by Dr. Bigelow, of Boston, and sold by Codman & Shurtleff, of that city. There are two small metallic tubes a few inches long soldered together, and by placing the point of exit of the spray at the lower part of the cell, the whole of the contents of

the cell are instantly blown out upon the metallic tubes. With a very little practice there is no necessity for polluting the comb with the putrid matter. Place the comb perfectly upright or a little leaned towards you, and there is no difficulty; yet if a drop should happen to run down the comb it would do no harm, but had better be carefully absorbed with a piece of old dry cotton cloth. I quite frequently do this with the bees on the comb, as it does them no harm, to say the least, to get well covered with the vapour.

It is not at all injurious to the larvæ after they are two or three days old, though it may be before that time, as I have noticed that after using the hyposulphate where there are eggs and very young larvæ, the next day the cells are perfectly clean. There are many interesting points which have come up during my summer's fight, which I would speak of, but I have already gone beyond all reasonable bounds in this communication.—EDWARD P. ABBE, *New Bedford, Mass.*

[The editor of the *American Bee Journal*, from which the foregoing letter is extracted, directs attention to it in a leading article, in which he declares that "Dr. Abbe deserves the cordial thanks of bee-keepers, both in this country and abroad, for so generously and promptly making known his remedy, and the mode of administering it."]

COAL-TARRING THE ROOF OF A BEE-HOUSE.

I SEE in a volume of the old series of the *Journal* that asphalt is not considered a good thing to cover a bee-house with. I am constructing a new house, and thought of coating the roof, which is of wood, with gas tar. Do you think it would be injurious to the bees? Bee-houses are very useful in our bleak neighbourhood. I leave it open behind, only close it in bad weather with a garden mat.—A NORTHUMBERLAND BEE-KEEPER.

It appears to us that if asphalted felt is objectionable to bees, coal tar must be at least equally so. We should, however, be obliged by the opinions of such of our apian readers as may have had experience in the use of both or either of these somewhat mal-odorous materials.]

PARISIAN DOINGS UNDER THE MARKETS.—There is generally something picturesque in the manner in which our *confères* on the other side of the channel describe the commonest things; and, if now and then they draw upon their imaginations for the facts, their mode of expression is their own. A journalist thus describes the vaults of the great *Halles Centrales*, or market, of Paris:—"The vaults extend under the pavilions of the market, just as an underground warehouse corresponds with the shop above; and in these vaults, lighted by 1200 gas jets, a multitude of industrious workers pursue their daily avocations. They are:—The *compteurs d'œufs*, who count the eggs coming in and going out; the *mirieurs*, who, with the aid of a candle, investigate the anatomy of each subject; the *préparateurs de fromages*, who teach the Chester to mellow, the Gruyère to weep, the brie to run, and prick the Roquefort; the *rongeurs d'os*, who built up their merchandise espalier-wise against the walls, and do a capital business; common bones sell for 5 francs the cwt., but choice bones are worth three times that sum; the *manipulateurs de beurre*, whose operations are indispensable for the preservation of that delicate article; the *plumeurs, tuteurs*, and *rideurs* of poultry, who strangle sixty birds per hour, and strip one naked in five minutes or less; the *graveurs de Pigeons*, who receive five sous for filling the crops of a dozen Pigeons with grain from their own mouths." There is a poetry, of its kind, in everything.—(*Food Journal*)

OUR LETTER BOX.

SILVER-SPANGLED HAMBURGH'S EAR-LOBES SCABBY (*A Duffer*).—It may be the scab or scurf is the result of frost-bite; if so, camphor ointment is the treatment. If pecked by bees, remove him. If arising from humour, use compound sulphur ointment. There is no reason why he should not again be exhibited. It is impossible to tell his age; spur is not infallible as an indication. You need not, and should not shorten the spur, unless the bird scratches his legs or is impeded in walking. Allow him one pullet, or remove him to some place where there will be no temptation to fret. It applies to all birds.

SILVER-SPANGLED HAMBURGH COCK'S COMBS AND EAR-LOBES (*Novice*).—The comb of a Hamburg cock should be firmly seated on the head; should be well forward, but not overhanging the nostrils; it should have a single pike behind, inclining upwards; it should be full of points; it should be even at the base, no hollow in the centre, no inclination to either side; it should be wider than the skull, and longer than the head, but not greatly so. The ear-lobe of a Hamburg should be the size of a

fourpenny piece, and as white as it is possible to be. It should not, under any circumstances, exceed the dimensions of a sixpence.

DOCKING BANTAMS (*Dorking Bantams*).—We have heard no similar complaints to yours. The birds should have been put in the class for "Any other variety." The error in stating the age must have arisen from carelessness. We advise you to write to the Committee.

POULTRY HEADS AND BEAKS SCURFY (*Constant Subscriber*).—We should try to wash, or to scrape or file the beak, but it must be delicately handled. The head and neck we should treat with compound sulphur ointment, rubbing thoroughly twice or oftener every day. We should rub the beaks in the same way.

TURKEYS (*M. C.*).—The hens will not lay till April, perhaps later. If you wish to breed Turkeys, the eggs are worth hatching, but not the first five or six. You must be your own judge as to when the cock can be dispensed with. We can only tell you he is not necessary throughout the laying season. Having done all that is required of him, he may at once be sent away. Many do not keep one, but hire him for a short time.

KEEPING POULTRY FOR EGG-LAYING (*G. F. M.*).—As the cost is but small, we advise you to buy the "Poultry Book" published at our office, price 6d., and also Baily's, which can likewise be had from us. We advise you to read the article in one of our back numbers on poultry gardening, it will give you an insight. You can run the number you name on two acres, and the cocks will soon find out who is master, and accommodate themselves to circumstances. Each will take a little walk of his own. You will have to supply some little inexpensive helps if you keep one hundred and fifty on two acres, but it can be done. Not knowing the position of your land, and whether there exist any present help for a poultry house, we can only give you some general rules applicable to all cases. It is better to have three houses with fifty, or two with seventy-five, than one with a hundred and fifty to roost in, unless you have an old barn or very large and lofty place. It is not essential, but it is healthier. Your house may be made of wood, or of cheaper material if you have it. All that is required is that it be wind and water-proof. The ventilation should be near the roof. The floor should be above the surrounding level, and made of gravel or road grit. There should be perching room for every bird, and no perch should be more than 2 feet from the ground. This is all that is necessary. Nine times out of ten the money spent on poultry houses is thrown away.

HAMBURGH'S EAR-LOBE WARTY (*H. T.*).—We have no doubt the wart of which you speak is the result of an injury to the outer skin or sac of the ear-lobe. If the bird was exhibited with a hen, she probably pecked it. If by himself, it is an accidental injury. Under any circumstances keep him by himself till it is healed, and treat it with softening and healing ointments. If put with hens while the wart remains they are sure to peck it and end to the destruction of the ear-lobe.

FEATHER-EATING HEN (*Hamburg*).—It is probably one hen that eats the feathers of the cock. Find her out and remove her; but you must also remove the cock, and rub his throat daily with spermaceti ointment till the stubs of the feathers appear. He must not go among the hens till the feathers are so hardened and mature that they cannot be distinguished from the others. When he is put with the hens they must be watched for a time.

POULTRY FOR EGG-PRODUCTION (*G. C.*).—Brahmas' eggs are larger than the Hamburgs', but you must have patience. A pullet's eggs are much smaller than a hen's. The largest eggs are laid by Spanish and Creve-Coeurs. Our belief is that, taking the weight during the year, the Hamburgs would be beaten, but in numbers they are very prolific. At a season like this "an egg's an egg for n' that," and small as they are, laying Hamburgs with their eggs now fill their owners' pockets as well as their basket. Eggs have seldom been so scarce or so dear.

POINTS OF HOUDAN COCK (*G. J. T.*).—Yellow feathers do not disqualify a Houdan cock. Red ones do. It is very desirable a bird should have no colours but black and white. The comb has two irregular spines in front, separating and become wider apart to their extremities, springing from a root in front of the head, which has a flattened-heart appearance, and from which emerge comblets half way down the upper beak, where they end in a curious small spiral. No colour disqualifies a Houdan cock but red.

BUFF COCHIN COCK'S COMB TURNING WHITE (*Gamma*).—Perhaps your cock's comb is frozen; if it is, rub it with strong camphor ointment. Perhaps it is the disease known as "white comb." To cure that, dress it frequently with compound sulphur ointment.

BREEDING GAME BANTAMS (—).—If you had only Black Reds and Duckwings together, you would have some pure of both breeds, and many of them remarkable for beauty of colour, but having added the Piles, we fear they will be "neither fish, nor flesh, nor good red herring."

FEEDING POULTRY (*One Who is Without Eggs*).—It is said there is a locality where if the cry, "Stop thief," is raised, every man runs away, and so if a thousand letters about eggs were received, nine hundred and ninety-nine would bear the same signature as your own. If you were to kill one of your very fat fowls, you would find another confirmation of our remarks about the internal fat, and you would find that such a dietary as produced it was unwholesome in the extreme. You would find all your birds possessing "fat livers," providing you with the principal ingredient of a *pate a foie gras*. The intestines become so choked with fat, none of the functions can be carried on in a healthy manner; and the liver suffers the most. In a healthy state it is so dark red brown as to be almost black, while the gall bladder lies under the left lobe, very dark green and full almost to bursting. In a fowl that is fat inside, the liver is three or four times its natural size, of a pale watery colour, and the gall bladder of a like hue, flaccid, and empty. This is the result of over-fattening, or of improper feeding. You can buy ground oats at Agate's Mill, Slaughter, Crawley, Sussex. We have a sample from a nearer place on trial, and shall be happy to give our readers the result. They are quite distinct from oatmeal.

WEST GLAMORGAN SHOW (*T. Moore*).—We know nothing of the Show, and it must have been small, as the Committee did not advertise it. You b. 73: remedy against the Judge. Point out to the Committee the errors you mention, and if you are correct they should employ a more competent Judge next year.

CRYSTAL PALACE SHOW (*W. D.*).—All the prizes omitted in the official List are inserted in our last number, page 506.

RABBITS AT THE YORK SHOW.—Mr. Hudson says that there are two or three omissions in his note which have caused considerable misapprehension, and asks that the following be inserted:—"The medal was taken by a pair of well-matched Himalayas, belonging to Mr. Butterworth, Rochdale. Mr. J. Boyle, Jun., Blackburn, showed two pairs in the class. The does were gems, and best in the class, but the bucks were poor. A great many others were also badly matched. Angoras were only moderate, many being dirty and poor in wool. The 'Any other Variety' class was good. Mr. Boyle took first with a pair of Grey and White Dutch, the finest for points and colours I have ever seen; this pair being fortunately shown in a good light. The second prize was awarded to a pair of Hare Rabbits, splendid specimens, but badly placed for being seen. This class was well judged. Mr. Easton entered his fine old Silver-Greys, winners of above forty prizes. Mr. Boyle also showed Silver-Greys and Silver-Creams—the best bred in England, not forgetting the fine specimens shown by Mr. Royds, Rochdale. I think these Rabbits ought to have a class to themselves, seeing the Committee withheld the two first 2ls. prizes where cups were awarded.—S. G. HUDSON."

BINGLEY SHOW.—Mr. Firth won the cup for the best pen of Barbs, Owls, and Jacobins, as is mentioned in our report to day. We had a catalogue with the prizes written in, and Mr. Firth's winning the cup was omitted in it.

VARIOUS (*Berkhamstead*).—The purple berries of the overgreen Berberies are not injurious to fowls. Millet seed can be obtained of any wholesale corn dealer in London. The journals you mention are American.

TURBITS (*M. Tyler*).—We believe there has been some dispute as to the way a Turbit should carry its wings, whether above or below the tail. We incline to think the former is the correct carriage; and we are strengthened in this belief, as in every portrait of a Turbit from the time of the "Treatise on Pigeons" (A. D. 1755) to the present time, this bird is represented carrying the points of its wings above the tail. We believe there is no care for scrofula either in man or Pigeon. Apply lukewarm water with a bit of alum to the bird's eyes.

CARRIERS' THINGS (*A. B.*).—The feathers you mention would not absolutely disqualify the bird, but it would be better if they were not there.

BONEDUST FOR CHICKENS (*G. G.*).—Bonedust mixed with their soft food is good for any chickens.

METEOROLOGICAL OBSERVATIONS

In the Suburbs of London for the week ending December 27th.

DATE.	BAROMETRE.		THERMOMETER.				Wind.	Rain
	Max.	Min.	Air.		Earth.			
			Max.	Min.	1 ft.	2 ft.		
Wed. . . 21	29.838	29.662	32	21	43	43	E.	.00
Thurs. . . 22	29.864	29.844	28	9	40	41	E.	.00
Fri. . . . 23	29.888	29.800	34	6	36	39	N.	.00
Sat. . . . 24	29.696	29.614	28	2	35	38	N.E.	.00
Sun. . . . 25	29.646	29.598	31	14	34	38	N.E.	.00
Mon. . . . 26	29.898	29.724	34	16	34	36	N.	.00
Tues. . . 27	29.844	29.688	31	25	35	35	N.E.	.00
Mean. . .	29.802	29.704	31.57	13.29	33.71	38.71	..	0.00

- 21.—Overcast; snow; cold wind, sharp frost.
- 22.—Sharp frost; snow; clear and frosty.
- 23.—Intense frost; fine, frosty; clear and frosty.
- 24.—Intense frost; frosty fog; frosty fog at night.
- 25.—Sharp frost; cold wind; overcast and frosty.
- 26.—Overcast, cold wind; densely overcast; slight snow.
- 27.—Sharp frost; overcast; heavy fall of snow.

COVENT GARDEN MARKET.—DECEMBER 28.

Owing to the holidays business is almost suspended, and we shall have but few changes to report for another week. Good vegetables are somewhat scarcer, and will rapidly advance in price should this weather continue.

	FRUIT.				VEGETABLES.			
	s. d.	s. d.	s. d.	s. d.	s. d.	s. d.	s. d.	s. d.
Apples.....	1 sieve	0 2	0 2	0 2	Mulberries.....	lb.	0 0	0 0
Apricots.....	doz.	0 0	0 0	0 0	Nectarines.....	doz.	0 0	0 0
Cherries.....	lb.	0 0	0 0	0 0	Oranges.....	doz.	0 0	0 0
Cherants.....	bushel	10	13	6	Pears, kitchen.....	doz.	1 0	0 0
Currants.....	sieve	0 0	0 0	0 0	Pears, dessert.....	doz.	1 0	0 0
Black.....	doz.	0 0	0 0	0 0	Onions.....	bushel	3 0	0 0
Figs.....	doz.	0 0	0 0	0 0	Pine Apples.....	lb.	3 0	0 0
Filberts.....	lb.	0 0	0 0	0 0	Plums.....	1 sieve	1 6	0 0
Cobs.....	lb.	2 0	2 6	0 0	Quinces.....	doz.	0 0	0 0
Gooseberries.....	quart	0 0	0 0	0 0	Raspberries.....	lb.	0 0	0 0
Grapes, Hothouse.....	lb.	4 0	8 0	0 0	Strawberries.....	lb.	0 0	0 0
Lemons.....	100 6	0 10	0 10	0 10	Walnuts.....	bushel	10 0	16 0
Melons.....	each	1 0	4 0	0 0	do.....	100	1 0	2 0
VEGETABLES.								
Artichokes.....	doz.	0 0	0 0	0 0	Leeks.....	bunch	0 4	0 0
Asparagus.....	100 0	0 0	0 0	0 0	Lettuces.....	doz.	0 9	1 0
Beans, kidney.....	100 0	0 0	0 0	0 0	Mushrooms.....	pottle	1 0	2 6
Broad.....	bushel	0 0	0 0	0 0	Mustard & Cress.....	punnet	0 2	0 0
Beet, Red.....	doz.	2 0	3 0	0 0	Onions.....	bushel	3 0	0 0
Broccoli.....	bundle	0 9	1 6	0 0	Pickling.....	quart	0 4	0 0
Brussels Sprouts.....	1 sieve	2 0	3 0	0 0	Parsley.....	sieve	3 0	0 6
Cabbage.....	doz.	1 0	2 0	0 0	Parsnips.....	doz.	0 9	1 6
Capsicums.....	100 0	0 0	0 0	0 0	Peas.....	quart	0 0	0 0
Carrots.....	bunch	0 4	0 8	0 0	Potatoes.....	bushel	2 0	4 0
Calliflower.....	doz.	3 0	6 0	0 0	Rhubarb.....	doz.	3 0	4 0
Celery.....	bundle	1 6	2 0	0 0	Rushes.....	doz.	0 6	1 0
Coleworts.....	doz.	0 6	0 8	0 0	Rhubarb.....	bundle	0 0	0 0
Cucumbers.....	each	0 9	1 6	0 0	Savoy.....	doz.	1 6	2 0
Cucumbers.....	pickling	doz.	0 0	0 0	Sea-kale.....	basket	2 0	2 0
Endive.....	doz.	2 0	0 0	0 0	Sballots.....	lb.	0 0	0 3
Fennel.....	bunch	0 3	0 0	0 0	Spinach.....	bushel	2 0	2 0
Garlic.....	lb.	0 8	0 0	0 0	Tomatoes.....	doz.	3 0	0 0
Herbs.....	bunch	0 3	0 0	0 0	Turnips.....	bunch	0 6	0 0
Horseradish.....	bundle	3 0	6 0	0 0	Vegetable Marrows.....	doz.	0 0	0 0



